



849 NW STATE ROAD 45  
NEWBERRY, FL 32669 USA  
PH: 888.472.2424 OR 352.472.5500  
FAX: 352.472.2030  
EMAIL: [INFO@TIMCOENGR.COM](mailto:INFO@TIMCOENGR.COM)  
[HTTP://WWW.TIMCOENGR.COM](http://WWW.TIMCOENGR.COM)

## IC RSS-119, RSS-GEN TEST REPORT

<b>APPLICANT</b>	DAMM CELLULAR SYSTEMS A/S
	MOLLEGADE 68 6400 SONDERBORG
<b>FCC ID</b>	Z5W-104013
<b>IC CERTIFICATION</b>	10159A-104013
<b>MODEL NUMBER</b>	TR412 Transceiver 450-460/ 460-470 MHz
<b>PRODUCT DESCRIPTION</b>	TX Module
<b>DATE SAMPLE RECEIVED</b>	1/25/2012
<b>DATE TESTED</b>	1/26/2012
<b>TESTED BY</b>	Joe Scoglio
<b>APPROVED BY</b>	Mario R. de Aranzeta
<b>TIMCO REPORT NO.</b>	213AT12TestReport.doc
<b>TEST RESULTS</b>	<input checked="" type="checkbox"/> PASS <input type="checkbox"/> FAIL

**THE ATTACHED REPORT SHALL NOT BE REPRODUCED EXCEPT IN FULL  
WITHOUT THE WRITTEN APPROVAL OF TIMCO ENGINEERING, INC.**



Testing Certificate #0955-01



**TABLE OF CONTENTS**

GENERAL REMARKS..... 3  
GENERAL INFORMATION..... 4  
GENERAL INFORMATION (cont'd)..... 5  
GENERAL INFORMATION (cont'd)..... 6  
TEST PROCEDURES ..... 7  
RF POWER OUTPUT ..... 8  
MODULATION CHARACTERISTICS..... 9  
AUDIO FREQUENCY RESPONSE ..... 10  
AUDIO LOW PASS FILTER..... 10  
AUDIO INPUT VERSUS MODULATION ..... 10  
OCCUPIED BANDWIDTH..... 11  
SPURIOUS EMISSIONS AT ANTENNA TERMINALS (CONDUCTED)..... 16  
FIELD STRENGTH OF SPURIOUS EMISSIONS..... 19  
TRANSIENT FREQUENCY BEHAVIOR..... 21  
EMC EQUIPMENT LIST ..... 24  
FREQUENCY STABILITY..... 25

Applicant: DAMM CELLULAR SYSTEMS A/S  
FCC ID: Z5W-104013  
IC CERT #: 10159A-104013  
Report: D\DAMM\213AT12\213AT12TestReport.doc

**GENERAL REMARKS**

The attached report shall not be reproduced except in full without the written permission of Timco Engineering Inc.

The test results relate only to the items tested.

**Summary**

The device under test does:

- fulfill the general approval requirements as identified in this test report
- not fulfill the general approval requirements as identified in this test report

**Attestations**

This equipment has been tested in accordance with the standards identified in this test report. To the best of my knowledge and belief, these tests were performed using the measurement procedures described in this report.

All instrumentation and accessories used to test products for compliance to the indicated standards are calibrated regularly in accordance with ISO 17025: 2005 requirements.



Testing Certificate # 0955-01

I attest that the necessary measurements were made, under my supervision, at:

Timco Engineering Inc.  
849 NW State Road 45  
Newberry, Fl 32669



**Authorized Signatory Name:**

Mario de Aranzeta C.E.T.  
Compliance Engineer/ Lab. Supervisor

**Date:** 01/26/2012

Applicant: DAMM CELLULAR SYSTEMS A/S  
FCC ID: Z5W-104013  
IC CERT #: 10159A-104013  
Report: D\DAMM\213AT12\213AT12TestReport.doc

**GENERAL INFORMATION**  
**DUT Specification**

<b>DUT Description</b>	TX module
<b>FCC ID</b>	Z5W-104013
<b>IC Certification</b>	10159A-104013
<b>Model Number</b>	TR412 Transceiver 450-460/460-470 MHz
<b>Serial Number</b>	N/A
<b>Operating Frequency</b>	TX: 450 – 460 - 470 MHz
<b>Test Frequencies</b>	460, 465, and 470 MHz
<b>Type of Emission</b>	0.35 TETRA and 0.20 modified TETRA
	21K0D1W, 21K0D1D, 21K0D1E, 21K0D7W 20K0D1W, 20K0D1D, 20K0D1E, 20K0D7W
<b>Modulation</b>	$\pi/4$ DQPSK
<b>DUT Power Source</b>	<input checked="" type="checkbox"/> 110-120Vac/50- 60Hz
	<input type="checkbox"/> DC Power 12V
	<input type="checkbox"/> Battery Operated Exclusively
<b>Test Item</b>	<input type="checkbox"/> Prototype
	<input checked="" type="checkbox"/> Pre-Production
	<input type="checkbox"/> Production
<b>Type of Equipment</b>	<input checked="" type="checkbox"/> Fixed
	<input type="checkbox"/> Mobile
	<input type="checkbox"/> Portable
<b>Test Conditions</b>	Temperature was 26°C Relative humidity of 50%.
<b>Modification to the DUT</b>	None
<b>Test Exercise</b>	The DUT was placed in continuous transmit mode.
<b>Applicable Standards</b>	ANSI/TIA 603-C:2004, FCC CFR 47 Part 90, IC RSS-119, RSS-GEN
<b>Test Facility</b>	Timco Engineering Inc. at 849 NW State Road 45 Newberry, FL 32669 USA.

Applicant: DAMM CELLULAR SYSTEMS A/S  
 FCC ID: Z5W-104013  
 IC CERT #: 10159A-104013  
 Report: D\DAMM\213AT12\213AT12TestReport.doc

**GENERAL INFORMATION (cont'd)**  
**DUT Specification**

The system as tested consists of the transceiver module combined with a power supply module, CPU module, and broadband filter assembly. This is combined in a single 19inch rack assembly. The unit is detailed in the user's manual.



Applicant: DAMM CELLULAR SYSTEMS A/S  
FCC ID: Z5W-104013  
IC CERT #: 10159A-104013  
Report: D\DAMM\213AT12\213AT12TestReport.doc

**GENERAL INFORMATION (cont'd)**  
**DUT Specification**

TR-412 Transceiver



Applicant: DAMM CELLULAR SYSTEMS A/S  
FCC ID: Z5W-104013  
IC CERT #: 10159A-104013  
Report: D\DAMM\213AT12\213AT12TestReport.doc

## TEST PROCEDURES

**Power Line Conducted Interference:** The procedure used was ANSI/TIA 603-C: 2004 using a 50uH LISN. Both lines were observed with the DUT transmitting. The bandwidth of the spectrum analyzer was 10 kHz with an appropriate sweep speed.

**Bandwidth 20 dB:** The measurements were made with the spectrum analyzer's resolution bandwidth (RBW) = 1 MHz and the video bandwidth (VBW) = 3 MHz and the span set as shown on plot.

**Power Output:** The RF power output was measured at the antenna feed point using a peak power meter.

**Antenna Conducted Emissions:** The RBW = 100 kHz, VBW = 300 kHz and the span set to 10 MHz and the spectrum was scanned from 30 MHz to the 10<sup>th</sup> harmonic of the fundamental. Above 1 GHz the resolution bandwidth was 1 MHz and the VBW = 3 MHz and the span to 50 MHz.

**Radiation Interference:** The test procedure used was ANSI/TIA 603-C: 2004 using an Agilent spectrum receiver with pre-selector. The bandwidth (RBW) of the spectrum receiver was 100 kHz up to 1 GHz and 1 MHz above 1 GHz with an appropriate sweep speed. The VBW above 1 GHz was 3 MHz. The analyzer was calibrated in dB above a micro volt at the output of the antenna.

Applicant: DAMM CELLULAR SYSTEMS A/S  
FCC ID: Z5W-104013  
IC CERT #: 10159A-104013  
Report: D\DAMM\213AT12\213AT12TestReport.doc

## RF POWER OUTPUT

**Rule Part No.:** FCC Part 2.1046(a), IC RSS-119 4.1 and 5.4, RSS-GEN 4.8

### Test Requirements:

**Method of Measurement:** RF power is measured by connecting a 50-ohm, resistive wattmeter to the RF output connector. With a nominal battery voltage, and the transmitter properly adjusted the RF output measures:

### Test Setup Diagram:

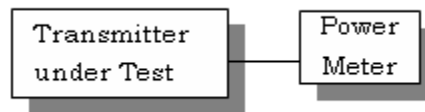

### Test Data:

OUTPUT POWER: HIGH – 12.0 Watts  
LOW - 0.5 Watts

### Part 2.1033 (C)(8) DC Input into the final amplifier

HIGH POWER SETTING INPUT POWER:  $(26\text{ V}) \cdot (3\text{ A}) = 78\text{ Watts}$

Applicant: DAMM CELLULAR SYSTEMS A/S  
FCC ID: Z5W-104013  
IC CERT #: 10159A-104013  
Report: D\DAMM\213AT12\213AT12TestReport.doc



**MODULATION CHARACTERISTICS**

**Part 2.1033(c)**

**Part 2.1033(c) (4)** Type of Emission:

Type of Emission:  $\pi/4$ DQPSK TETRA as defined in EN 300 392-2.

TETRA is a digital, trunked radio technology that operates with Time Division Multiple Access (TDMA) in four-slot channels within a twenty-five kilohertz bandwidth.

This unit has two distinct and different but similar modulation schemes. One being as defined above and the second mode which is similar and implemented through a software change only where:

**Description of the modified modulation:**

From ETSI EN 300 392-2 part 5.5 the requirement for the output spectrum of a TETRA signal  $G(f)$  is:

$$G(f) = 1 \quad \text{for} \quad |f| \leq (1 - \alpha)/2T$$

$$G(f) = \sqrt{0.5 \left( 1 - \sin \left( \pi \left( 2|f|T - 1 \right) / 2\alpha \right) \right)} \quad \text{for} \quad (1 - \alpha)/2T \leq |f| \leq (1 + \alpha)/2T$$

$$G(f) = 0 \quad \text{for} \quad |f| \geq (1 + \alpha)/2T$$

Where  $\alpha$  is the roll-off factor, which determines the width of the transmission band at a given symbol rate. For TETRA the value of  $\alpha$  shall be 0.35.

This spectrum can't fulfill the requirement of the FCC. Therefore the shape of the output spectrum has been modified by changing  $\alpha$  from 0.35 to 0.20. This gives a narrowed spectrum that meets the FCC requirements for the 20 kHz bandwidth.

The TETRA and modified modulation meets the spectrum efficiency requirements of Part 90.

## **AUDIO FREQUENCY RESPONSE**

**Rule Part No.:** FCC Part 2.1047(a)(b), IC RSS-119 5.2

### **Test Requirements:**

### **Method of Measurement:**

The audio frequency response was measured in accordance with ANSI/TIA 603-C: 2004. A curve or equivalent data showing the frequency response of the audio modulating circuit over a range of 100 – 5000Hz shall be submitted. The audio frequency response curve is shown below.

### **AUDIO FREQUENCY RESPONSE PLOT**

Digitally encoded voice

## **AUDIO LOW PASS FILTER**

## **VOICE MODULATED COMMUNICATION EQUIPMENT**

**Part 2.1047(a) Voice modulated communication equipment:** For equipment required to have an audio low-pass filter, a curve showing the frequency response of the filter, or of all the circuitry installed between the modulation limiter and the modulated stage shall be submitted.

### **AUDIO LOW PASS FILTER**

Digitally encoded voice

## **AUDIO INPUT VERSUS MODULATION**

**Rule Part No.:** FCC Part 2.1047(b) & 90, IC RSS-119 5.2

### **Test Requirements:**

**Method of Measurement:** **Modulation cannot exceed 100%**, The audio input level needed for a particular percentage of modulation was measured in accordance with ANSI/TIA 603-C: 2004. The audio input curves versus modulation are shown below. Curves are provided for audio input frequencies of 300, 1000, and 2500 Hz.

### **Test data:**

Modulation Limiting Plot

N/A

Digitally encoded voice

Applicant: DAMM CELLULAR SYSTEMS A/S  
FCC ID: Z5W-104013  
IC CERT #: 10159A-104013  
Report: D\DAMM\213AT12\213AT12TestReport.doc

## **OCCUPIED BANDWIDTH**

### **FCC Part 2.1049(c), RSS-GEN 4.6 EMISSION BANDWIDTH FCC Part 90.210(b) RSS-119 4.2 25 kHz Channel Spacing**

Data in the plots show that on any frequency removed from the assigned frequency by more than 50%, but not more than 100%: At least 25dB. On any frequency removed from the assigned frequency by more than 100%, but not more than 250%: At least 35 dB. On any frequency removed from the assigned frequency by more than 250%, of the authorized bandwidth: At least  $43 + 10\log(P)$ dB.

### **Part 90.210(c) 25 kHz Channel Spacing Not Equipped with a Low Pass Filter**

For transmitters that are not equipped with an audio low pass filter pursuant to S90.211 (b), the power of any emission must be attenuated below the un-modulated carrier output power as follows; (1) On any frequency removed from the center of the authorized bandwidth by a displacement frequency ( $f_d$  in kHz) of more than 5 kHz but not more than 10 kHz: At least  $83 \log(f_d/5)$  dB; (2) ON any frequency removed from the center of the authorized bandwidth by a displacement frequency ( $f_d$  in kHz) of more than 10 kHz, but not more than 250% of the authorized bandwidth: At least  $29 \log(f_d/11)$ dB or 50 dB, whichever is the lesser attenuation; (3) On any frequency removed from the center of the authorized bandwidth by more than 250% of the authorized bandwidth: At least  $43 + 10 \log(P_o)$ dB.

Applicant: DAMM CELLULAR SYSTEMS A/S  
FCC ID: Z5W-104013  
IC CERT #: 10159A-104013  
Report: D\DAMM\213AT12\213AT12TestReport.doc

**OCCUPIED BANDWIDTH MEASUREMENT**

**Test procedure:** ANSI/TIA-603-C: 2004 paragraph 2.2.11.

**Test Setup Diagram:**

OCCUPIED BANDWIDTH MEASUREMENT

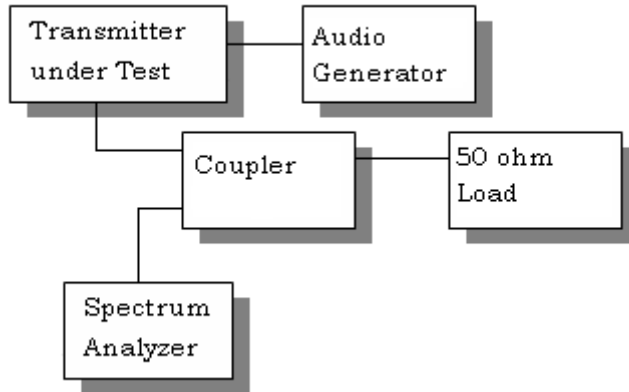

**Test Data:** See the plots below  
Three places in the band were measured and the worst case presented.

0.35 TETRA  
25.0 kHz – DIGITAL

NOTES:

RSS 119 Mask Y

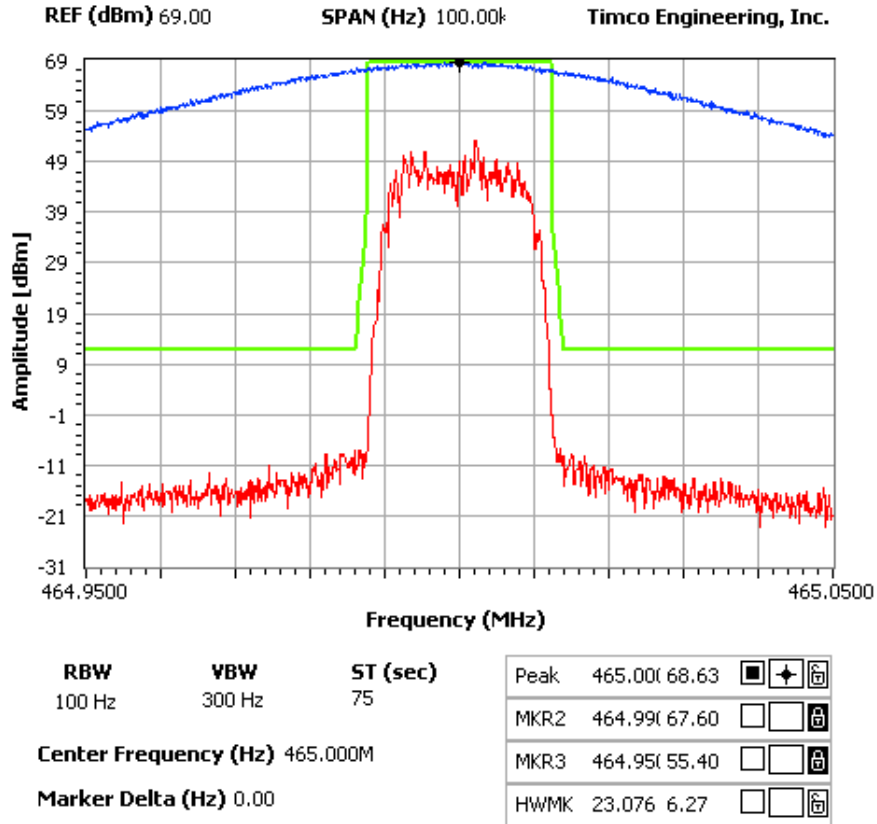

Applicant: DAMM CELLULAR SYSTEMS A/S  
 FCC ID: Z5W-104013  
 IC CERT #: 10159A-104013  
 Report: D\DAMM\213AT12\213AT12TestReport.doc

Mask B  
0.20 modified TETRA

NOTES:

FCC 90.210 Mask B

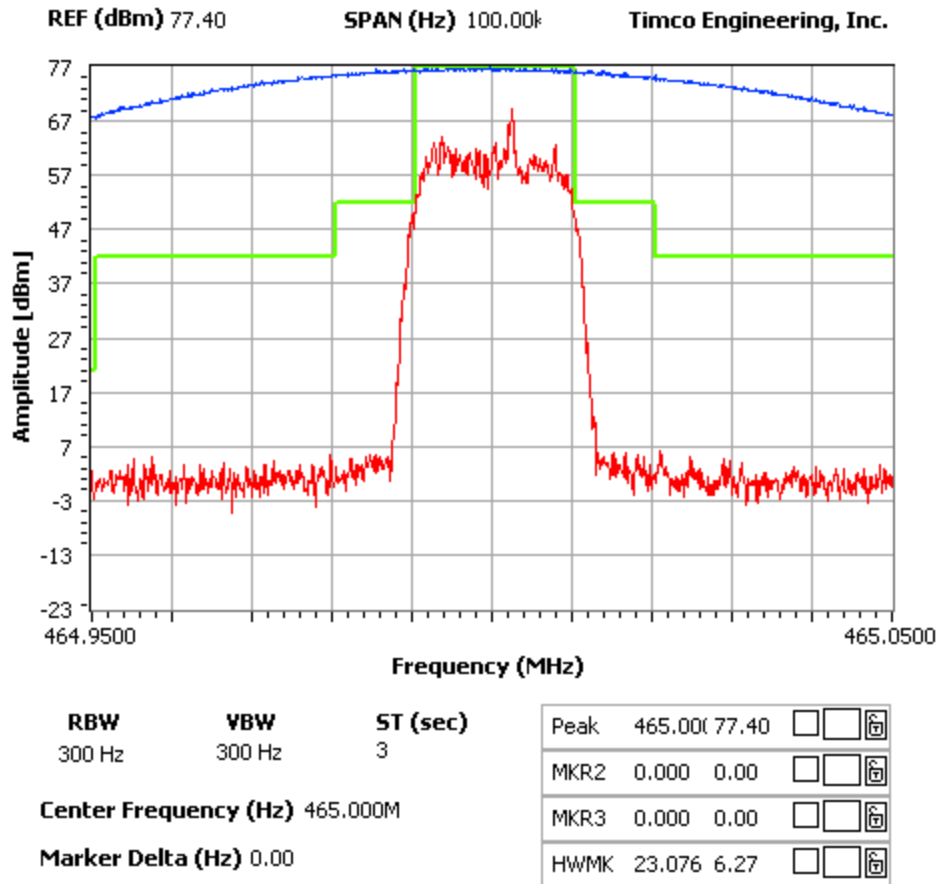

Applicant: DAMM CELLULAR SYSTEMS A/S  
 FCC ID: Z5W-104013  
 IC CERT #: 10159A-104013  
 Report: D\DAMM\213AT12\213AT12TestReport.doc

0.20 modified TETRA  
Mask C

NOTES:

FCC 90.210 Mask C

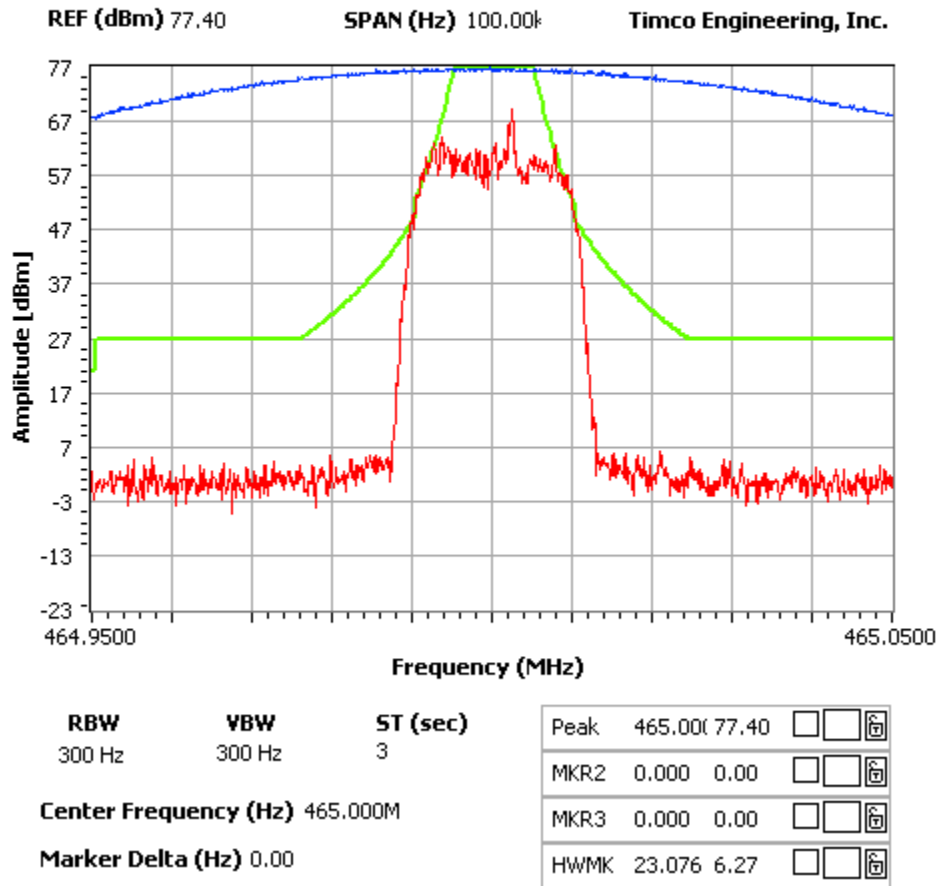

Applicant: DAMM CELLULAR SYSTEMS A/S  
 FCC ID: Z5W-104013  
 IC CERT #: 10159A-104013  
 Report: D\DAMM\213AT12\213AT12TestReport.doc

**SPURIOUS EMISSIONS AT ANTENNA TERMINALS (CONDUCTED)**

**Rule Part No.:** FCC Part 2.1051(a), RSS-GEN 7.1.4

**Requirements:** 25 kHz Channel Spacing = 50 dBc (for 5 Watts)

**Method of Measurement:** The carrier was modulated 100% using a 2500 Hz tone. The spectrum was scanned from 0.4 to at least the 10th harmonic of the fundamental. The measurements were made in accordance with standard ANSI/TIA 603-C: 2004.

FCC Limit for:  
 25 kHz Channel Spacing = 50  
 12.5 kHz Spacing = 57  
 6.25 kHz Channel Spacing = N/A

**Test Data:**

TF HIGH POWER	EF	dB below carrier		TF LOW POWER	EF	dB below carrier
460	460	0		460	460	0
	920	114.4			920	100.2
	1380	95.7			1380	98.9
	1840	113.6			1840	99.1
	2300	115.6			2300	105.6
	2760	117.6			2760	105.8
	3220	119			3220	107
	3680	119.6			3680	104.4
	4140	117.3			4140	107.1
	4600	117.2			4600	105

TF HIGH POWER	EF	dB below carrier		TF LOW POWER	EF	dB below carrier
465	465	0		465	465	0
	930	111			930	97.8
	1395	88.1			1395	97.2
	1860	110.8			1860	101.7
	2325	115.6			2325	101.6
	2700	117.8			2700	104.7
	3255	117.7			3255	103
	3720	118.1			3720	102.2
	4185	117.6			4185	103.5
	4650	117.7			4650	102.7

Applicant: DAMM CELLULAR SYSTEMS A/S  
 FCC ID: Z5W-104013  
 IC CERT #: 10159A-104013  
 Report: D\DAMM\213AT12\213AT12TestReport.doc



<b>TF HIGH POWER</b>	<b>EF</b>	<b>dB below carrier</b>		<b>TF LOW POWER</b>	<b>EF</b>	<b>dB below carrier</b>
470	470	0		470	470	0
	940	99.2			940	99.3
	1410	92.3			1410	98.1
	1880	114.3			1880	100.4
	2350	124.3			2350	111.2
	2820	124.9			2820	111
	3290	126.3			3290	112.6
	3760	124.7			3760	112.1
	4230	128			4230	112.5
	4700	124.1			4700	111.2

Applicant: DAMM CELLULAR SYSTEMS A/S  
 FCC ID: Z5W-104013  
 IC CERT #: 10159A-104013  
 Report: D\DAMM\213AT12\213AT12TestReport.doc

### Method of Measuring Conducted Spurious Emissions

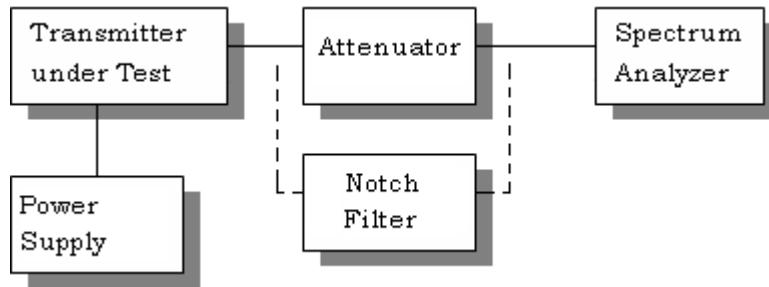

**METHOD OF MEASUREMENT:** The procedure used was ANSI/TIA 603-C: 2004. The measurements were made at TIMCO ENGINEERING INC. 849 N.W. State Road 45, Newberry, Florida 32669.

Applicant: DAMM CELLULAR SYSTEMS A/S  
FCC ID: Z5W-104013  
IC CERT #: 10159A-104013  
Report: D\DAMM\213AT12\213AT12TestReport.doc

**FIELD STRENGTH OF SPURIOUS EMISSIONS**

**Rule Parts. No.:** FCC Part 2.1053, RSS-GEN 4.9

**Requirements:** The FCC limits for radiated emissions are the same as previously stated for the conducted emissions.

**METHOD OF MEASUREMENT:** The tabulated data shows the results of the radiated field strength emissions test. The spectrum was scanned from 30 MHz to at least the tenth harmonic of the fundamental. This test was conducted per ANSI/TIA 603-C: 2004 using the substitution method.

Measurements were made at the test site of Timco Engineering, Inc. located at 849 NW State Road 45, Newberry, FL 32669.

**Test Setup Diagram:**

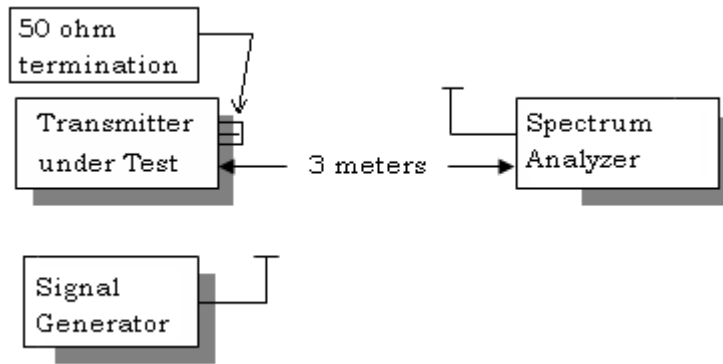

Three places in the band were checked and the worst case data presented below:

**Test Data:**

**High Power**

Emission Frequency MHz	Ant. Polarity	dB Below Carrier (dBc)
460.00	V	0
920.00	V	80.1
1840.00	H	89.2
2760.00	H	93.9

**Low Power**

Emission Frequency MHz	Ant. Polarity	dB Below Carrier (dBc)
460.00	V	0
920.00	V	91.8

**High Power**

Emission Frequency MHz	Ant. Polarity	dB Below Carrier (dBc)
465.00	V	0
930.00	V	78.7

**Low Power**

Emission Frequency MHz	Ant. Polarity	dB Below Carrier (dBc)
465.00	V	0
930.00	V	86.0

**HIGH POWER**

Emission Frequency MHz	Ant. Polarity	dB Below Carrier (dBc)
470.00	V	0
940.00	V	77.4
1880.00	V	89.4

**LOW POWER**

Emission Frequency MHz	Ant. Polarity	dB Below Carrier (dBc)
470.00	V	0
940.00	V	86.6

**TRANSIENT FREQUENCY BEHAVIOR**

**FCC Part 2.1055(a)(1)**

**FCC Part 90.214, IC RSS-119 5.8**

**REQUIREMENTS:** Transmitters designed to operate in the 150-174 MHz and 421-512 MHz frequency bands must maintain transient frequencies within the maximum transient frequencies within the maximum frequency difference limits during the time intervals indicated:

Time Intervals	Maximum frequency difference	All Equipment	
		150-174 MHz	421-512 MHz

Transient Frequency Behavior for Equipment Designed to Operate on 25 kHz Channels

t <sub>1</sub> <sup>4</sup>	±25.0 kHz	5.0 ms	10.0 ms
t <sub>2</sub>	±12.5 kHz	20.0 ms	25.0 ms
t <sub>3</sub> <sup>4</sup>	±25.0 kHz	5.0 ms	10.0 ms

Transient Frequency Behavior for Equipment Designed to Operate on 12.5 kHz Channels

t <sub>1</sub> <sup>4</sup>	±12.5 kHz	5.0 ms	10.0 ms
t <sub>2</sub>	±6.25 kHz	20.0 ms	25.0 ms
t <sub>3</sub> <sup>4</sup>	±12.5 kHz	5.0 ms	10.0 ms

Transient Frequency Behavior for Equipment Designed to Operate on 6.25 kHz Channels

t <sub>1</sub> <sup>4</sup>	±6.25 kHz	5.0 ms	10.0 ms
t <sub>2</sub>	±3.125 kHz	20.0 ms	25.0 ms
t <sub>3</sub> <sup>4</sup>	±6.25 kHz	5.0 ms	10.0 ms

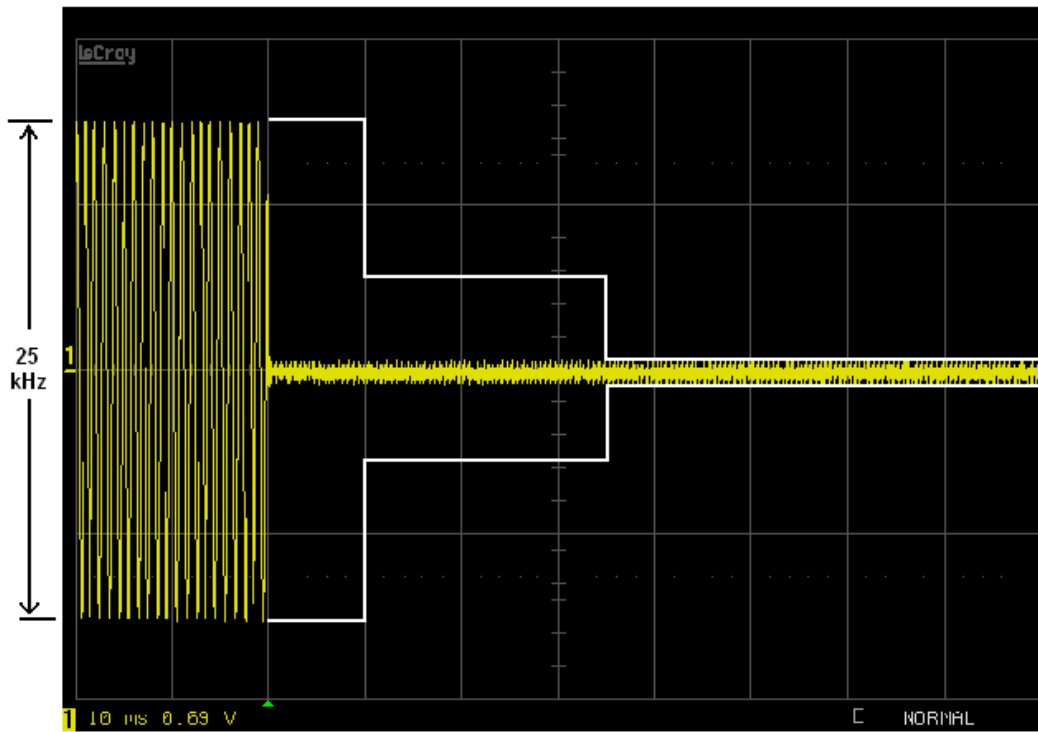

Turn on

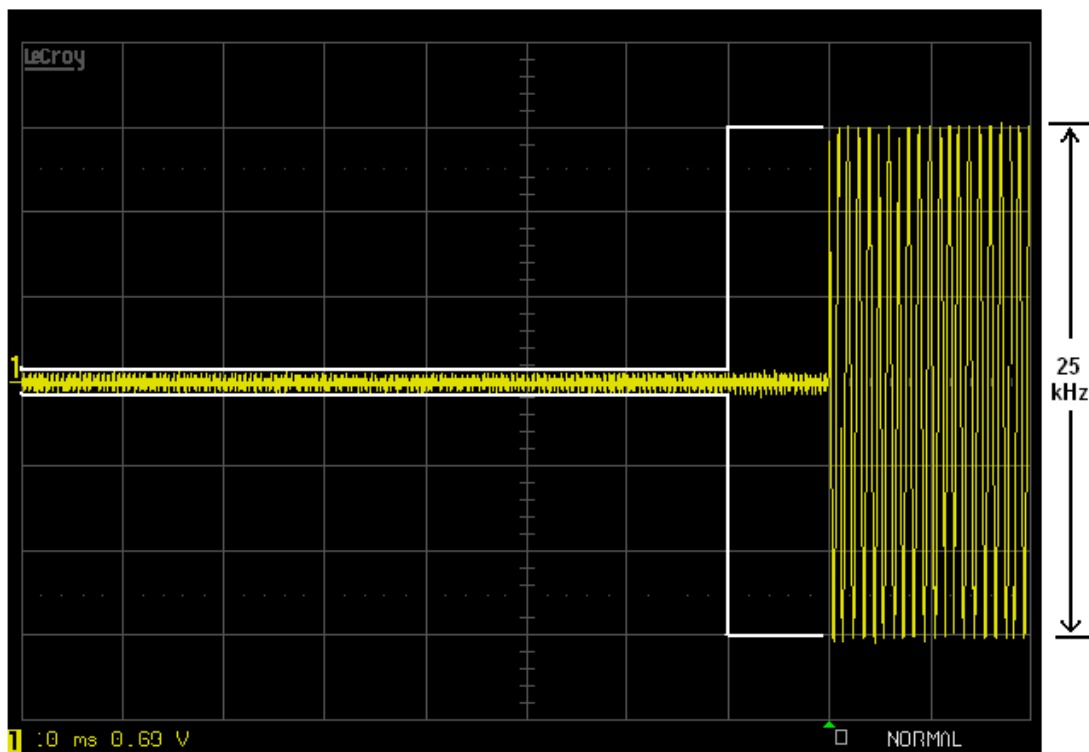

Turn off

Applicant: DAMM CELLULAR SYSTEMS A/S  
 FCC ID: Z5W-104013  
 IC CERT #: 10159A-104013  
 Report: D\DAMM\213AT12\213AT12TestReport.doc

**TEST PROCEDURE:** ANSI/TIA 603-C:2004 PARA 2.2.19

1. Using the variable attenuator the transmitter level was set to 40 dB below the test receivers maximum input level, then the transmitter was turned off.
2. With the transmitter off the signal generator was set 20dB below the level of the transmitter in the above step, this level will be maintained with the signal generator through-out the test.
3. Reduce the attenuation between the transmitter and the RF detector by 30 dB. With the levels set as above the transient frequency behavior was observed & recorded.

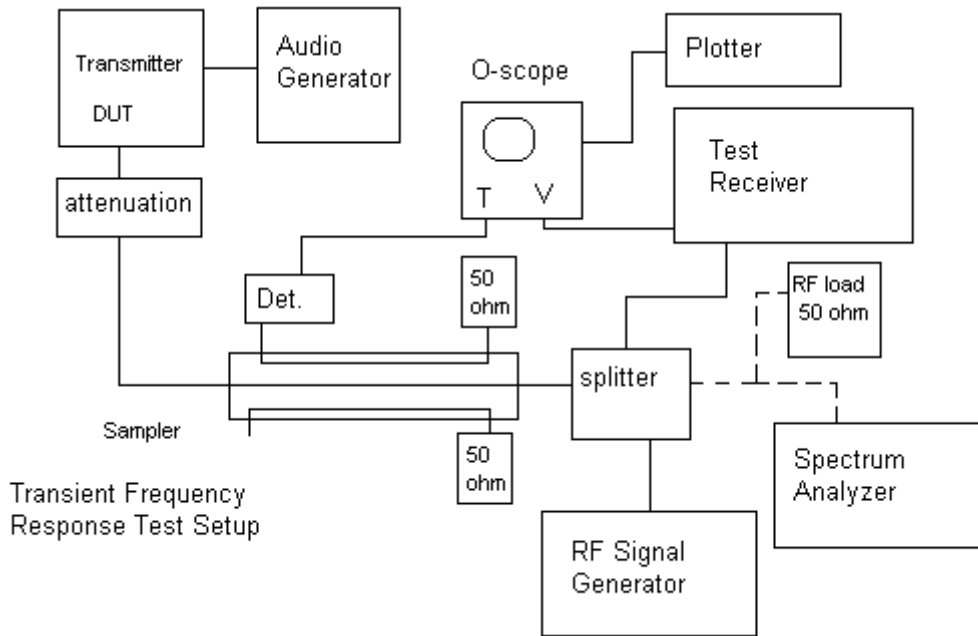

## EMC EQUIPMENT LIST

Device	Manufacturer	Model	Serial Number	Cal/Char Date	Due Date
Analyzer Tan Tower Spectrum Analyzer	HP	8566B Opt 462	3138A07786 3144A20661	11/24/09	10/28/13
Analyzer Tan Tower Preamplifier	HP	8449B-H02	3008A00372	11/21/09	10/28/13
Antenna: Biconnical	Eaton	94455-1	1096	05/04/11	05/04/13
Antenna: Log-Periodic	Electro-Metrics	LPA-25	1122	05/04/11	05/04/13
Frequency Counter	HP	5352B	2632A00165	06/22/11	06/22/13
Frequency Counter	HP	5385A	2730A03025	08/17/11	08/17/13
Signal Generator	HP	8640B	2308A21464	08/04/11	08/04/13
Hygro-Thermometer	Extech	445703	0602	06/15/11	06/15/13
Digital Multimeter	Fluke	77	35053830	09/09/11	09/09/13
Analyzer Tan Tower RF Preselector	HP	85685A	3221A01400	11/21/09	10/28/13
Antenna: Passive Loop	EMC Test Systems	EMCO 6512	9706-1211	06/02/09	06/02/12
Modulation Analyzer	HP	8901A	3435A06868	07/18/11	07/18/13
Analyzer Tan Tower Quasi-Peak Adapter	HP	85650A	3303A01690	11/22/09	10/28/13
Temperature Chamber	Tenney Engineering	TTRC	11717-7	06/18/10	06/18/12
Frequency Counter	HP	5385A	3242A07460	06/22/11	06/22/13
3/10-Meter OATS	TEI	N/A	N/A	12/31/11	12/31/13
3-Meter OATS	TEI	N/A	N/A	12/31/11	12/31/13
3-Meter Semi-Anechoic Chamber	Panashield	N/A	N/A	12/31/2011	012/31/13

Applicant: DAMM CELLULAR SYSTEMS A/S  
 FCC ID: Z5W-104013  
 IC CERT #: 10159A-104013  
 Report: D\DAMM\213AT12\213AT12TestReport.doc





Damm Cellular Systems A/S, Denmark

Doc. No.

Rev.

Date

0

2012-01-19

BS41x FREQUENCY STABILITY

## FREQUENCY STABILITY

**Date:** 2012-01-19

**Rule Parts. No.:** FCC Part 2.1055, Part 90.213, RSS-119 5.3, RSS-GEN 7.2.4

**Requirements:** Temperature range requirements: -30 to +50° C.  
Voltage Variation +, -15%  
±1.5 PPM

**Method of Measurements:** ANSI/TIA 603-C: 2004

**Equipment:** DAMM  
BS41x  
BSC412 SN: 10001798  
TR412 SN: 11000749

**Meas. Equipment:** Freq. Meas. Stabilock 4040 SN: 1625043  
Climate Chamber CoolTec II SN: P1083

### Test Data:

**Ref Frequency:** 462.5000 MHz

Assigned Frequency (Ref. Frequency) (MHz)		
Temperature (°C)	Frequency (MHz)	Frequency Stability (PPM)
-30	462.500006	+0.014
-20	462.500006	+0.014
-10	462.500005	+0.012
0	462.500003	+0.007
+10	462.500002	+0.005
+20	462.500002	+0.005
+30	462.500001	+0.002
+40	462.500000	+0.000
+50	462.500000	+0.000

Performed by: Morten Christensen, Engineer

Applicant: DAMM CELLULAR SYSTEMS A/S  
FCC ID: Z5W-104013  
IC CERT #: 10159A-104013  
Report: D\DAMM\213AT12\213AT12TestReport.doc