

FCC Radio Test Report

FCC ID: Z5N-7AM13

This report concerns (check one): Original Grant Class II Change

Project No. : 1507004
Equipment : Touch Switch
Model Name : LR7A-M13, LR3A-M13
Applicant : LoongYee Industry Co.,Ltd
Address : No.14, Lane 103, Sec.2,Zhongxing Rd, Wu Gu
Dist,24873 New Taipei City, Taiwan, R.O.C.

Date of Receipt : Jul. 01, 2015
Date of Test : Jul. 01, 2015~Oct. 13, 2015
Issued Date : Oct. 14, 2015
Tested by : BTL Inc.

Testing Engineer : Josh Lin
(Josh Lin)

Technical Manager : Jeff Yang
(Jeff Yang)

Authorized Signatory : Andy Chiu
(Andy Chiu)

B T L I N C .

B1, No.37, Lane 365, Yang Guang St.,
Nei-Hu District, Taipei City 114, Taiwan.
TEL: +886-2-2657-3299 FAX: +886-2-2657-3331

Declaration

BTL represents to the client that testing is done in accordance with standard procedures as applicable and that test instruments used has been calibrated with the standards traceable to National Measurement Laboratory (**NML**) of **R.O.C.**, or National Institute of Standards and Technology (**NIST**) of **U.S.A.**

BTL's reports apply only to the specific samples tested under conditions. It is manufacture's responsibility to ensure that additional production units of this model are manufactured with the identical electrical and mechanical components. **BTL** shall have no liability for any declarations, inferences or generalizations drawn by the client or others from **BTL** issued reports.

BTL's report must not be used by the client to claim product certification, approval, or endorsement by NVLAP, NIST, or any agency of the Federal Government.

This report is the confidential property of the client. As a mutual protection to the clients, the public and **BTL-self**, extracts from the test report shall not be reproduced except in full with **BTL's** authorized written approval.

BTL's laboratory quality assurance procedures are in compliance with the **ISO Guide17025** requirements, and accredited by the conformity assessment authorities listed in this test report.

Limitation

For the use of the authority's logo is limited unless the Test Standard(s)/Scope(s)/Item(s) mentioned in this test report is (are) included in the conformity assessment authorities acceptance respective.

Table of Contents	Page
1 . CERTIFICATION	6
2 . SUMMARY OF TEST RESULTS	7
2.1 TEST FACILITY	7
2.2 MEASUREMENT UNCERTAINTY	8
3 .GENERAL INFORMATION	9
3.1 GENERAL DESCRIPTION OF EUT	9
3.2 DESCRIPTION OF TEST MODES	10
3.3 BLOCK DIAGRAM SHOWING THE CONFIGURATION OF SYSTEM TESTED	11
3.4 DESCRIPTION OF SUPPORT UNITS	11
4 . EMC EMISSION TEST	12
4.1 CONDUCTED EMISSION MEASUREMENT	12
4.1.1 POWER LINE CONDUCTED EMISSION	12
4.1.2 TEST PROCEDURE	12
4.1.3 DEVIATION FROM TEST STANDARD	12
4.1.4 TEST SETUP	13
4.1.5 EUT OPERATING CONDITIONS	13
4.1.6 EUT TEST CONDITIONS	13
4.1.7 TEST RESULTS	13
4.2 RADIATED EMISSION MEASUREMENT	14
4.2.1 RADIATED EMISSION LIMITS	14
4.2.2 TESTPROCEDURE	15
4.2.3 DEVIATION FROM TEST STANDARD	15
4.2.4 TESTSETUP	16
4.2.5 EUT OPERATING CONDITIONS	17
4.2.6 EUT TEST CONDITIONS	17
4.2.7 TEST RESULTS (9KHZ 30MHZ)	17
4.2.8 TEST RESULTS (30MHZ to 1000 MHZ)	17
4.2.9 TEST RESULTS (ABOVE1000 MHZ)	18
5 . BANDWIDTH TEST	19
5.1 TEST PROCEDURE	19
5.2 DEVIATION FROM STANDARD	19
5.3 TEST SETUP	19
5.4 EUT OPERATION CONDITIONS	19
5.5 EUT TEST CONDITIONS	19
5.6 TEST RESULTS	19
6 . MEASUREMENT INSTRUMENTS LIST AND SETTING	20
7 . EUT TEST PHOTO	21

Table of Contents**Page**

ATTACHMENT A - CONDUCTED EMISSION	29
ATTACHMENT B -RADIATED EMISSION (9KHZ to 30MHZ)	34
ATTACHMENT C -RADIATED EMISSION (30MHZ TO 1000MHZ)	37
ATTACHMENT D -RADIATED EMISSION (ABOVE 1000MHZ)	42
ATTACHMENT E - BANDWIDTH	51

REPORT ISSUED HISTORY

Issued No.	Description	Issued Date
BTL-FCCP-1-1507004	Original Issue.	Oct. 14, 2015

1. CERTIFICATION

Equipment : Touch Switch
Brand Name : Loong Yee
Model Name : LR7A-M13, LR3A-M13
Applicant : LoongYee Industry Co.,Ltd
Manufacturer : LoongYee Industry Co.,Ltd
Address : No.14, Lane 103, Sec.2,Zhongxing Rd, Wu Gu Dist,24873 New Taipei City,
Taiwan, R.O.C.
Factory : LoongYee Industry Co.,Ltd
Address : No.14, Lane 103, Sec.2,Zhongxing Rd, Wu Gu Dist,24873 New Taipei City,
Taiwan, R.O.C.
Date of Test : Jul. 01, 2015~Oct. 13, 2015
Test Sample : Engineering Sample
Standard(s) : FCC Part15, Subpart C :2014 (15.249)/ ANSI C63.10-2013

The above equipment has been tested and found compliance with the requirement of the relative standards by BTL Inc..

The test data, data evaluation, and equipment configuration contained in our test report (Ref No. BTL-FCCP-1-1507004) were obtained utilizing the test procedures, test instruments, test sites that has been accredited by the Authority of TAF according to the ISO-17025 quality assessment standard and technical standard(s).

2. SUMMARY OF TEST RESULTS

Test procedures according to the technical standard(s):

FCC Part15, Subpart C (15.249)			
Standard Section	Test Item	Judgment	Remark
FCC			
15.207(a)	Conducted Emission	PASS	
15.205	Restricted Band of Operation	PASS	
15.209 15.249(a)	Radiated Emissions	PASS	
15.215(c)	20dB Bandwidth Test	PASS	

NOTE:

(1) "N/A" denotes test is not applicable to this device.

2.1 TEST FACILITY

Conducted emission Test:

C05: FCC RN:965108; FCC DN:TW1082)
No. 68-1, Ln. 169, Sec.2, Datong Rd., Xizhi Dist., New Taipei City 221, Taiwan

Radiated emission Test (Below 1 GHz):

CB08: (FCC RN: 614388; FCC DN: TW1054; IC Assigned Code: 4428C-1)
1F., No. 61, Ln. 77, Sing-ai Rd., Neihu Dist., Taipei City 114, Taiwan (R.O.C.)

Radiated emission Test (Above 1 GHz):

CB08: (FCC RN: 614388; FCC DN: TW1054; IC Assigned Code: 4428C-1)
1F., No. 61, Ln. 77, Sing-ai Rd., Neihu Dist., Taipei City 114, Taiwan (R.O.C.)

2.2 MEASUREMENT UNCERTAINTY

Where relevant, the following measurement uncertainty levels have been estimated for tests performed on the EUT as specified in CISPR 16-4-2.

The BTL measurement uncertainty is less than the CISPR 16-4-2 U_{CISPR} requirement.

A. Conducted emission test:

Test Site	Method	Measurement Frequency Range	U,(dB)
C05	CISPR	150 kHz ~ 30MHz	2.04

B. Radiated emission test:

Test Site	Method	Measurement Frequency Range	U,(dB)
CB08 (3m)	CISPR	9kHz ~ 150kHz	4.00
		150kHz ~ 30MHz	4.00

Test Site	Method	Measurement Frequency Range	Ant. H / V	U,(dB)
CB08 (3m)	CISPR	30MHz ~ 200MHz	V	3.06
		30MHz ~ 200MHz	H	2.58
		200MHz ~ 1,000MHz	V	3.50
		200MHz ~ 1,000MHz	H	3.10

Test Site	Method	Measurement Frequency Range	Ant. H / V	U,(dB)
CB08 (3m)	CISPR	1GHz ~ 6GHz	V	4.14
		1GHz ~ 6GHz	H	4.14
		6GHz ~ 18GHz	V	5.34
		6GHz ~ 18GHz	H	5.34

Test Site	Method	Measurement Frequency Range	U,(dB)
CB08 (3m)	CISPR	18 ~ 26.5 GHz	4.66
		26.5 ~ 40 GHz	4.74

Our calculated Measurement Instrumentation Uncertainty is shown in the tables above. These are our U_{lab} values in CISPR 16-4-2 terminology.

Since Table 1 of CISPR 16-4-2 has values of measurement instrumentation uncertainty, called U_{CISPR} , as follows:

Conducted Disturbance (mains port) – 150 kHz – 30 MHz: 3.6 dB

Radiated Disturbance (electric field strength on an open area test site or alternative test site) –

30 MHz – 1000 MHz: 5.2 dB

It can be seen that our U_{lab} values are smaller than U_{CISPR} .

If U_{lab} is less than or equal to U_{CISPR} , then:

- compliance is deemed to occur if no measured disturbance level exceeds the disturbance limit;
- non-compliance is deemed to occur if any measured disturbance level exceeds the disturbance limit.

If U_{lab} is greater than U_{CISPR} , then:

- compliance is deemed to occur if no measured disturbance level, increased by $(U_{lab} - U_{CISPR})$, exceeds the disturbance limit;
- non-compliance is deemed to occur if any measured disturbance level, increased by $(U_{lab} - U_{CISPR})$, exceeds the disturbance limit.

Note: Unless specifically mentioned, the uncertainty of measurement has not been taken into account to declare the compliance or non-compliance to the specification.

3.GENERAL INFORMATION

3.1 GENERAL DESCRIPTION OF EUT

Equipment	Touch Switch	
Brand Name	Loong Yee	
Model Name	LR7A-M13, LR3A-M13	
Model Difference	The current is different.model LR7A-M13 is 7A and model LR3A-M13 is 3A.	
Product Description	Operation Frequency	2.409GHz
	Modulation Technology	FSK(2.4Kbps)
	Data rate	
	Field Strength- LR7A-M13	91.89dBuV/m(Peak Max) 74.87dBuV/m(AVG Max)
	Field Strength- LR3A-M13	93.58dBuV/m(Peak Max) 73.59dBuV/m(AVG Max)
Power Source	AC Mains	
Power Rating	AC 120V 60Hz	

Note:

1. For a more detailed features description, please refer to the manufacturer's specifications or the user's manual.

2. Channel List:

Channel	Frequency (MHz)
01	2409

3 Table for Filed Antenna:

Ant.	Brand	Model Name	Antenna Type	Connector	Gain (dBi)	Note
1	N/A	N/A	PCB	N/A	-4.39	

3.2 DESCRIPTION OF TEST MODES

To investigate the maximum EMI emission characteristics generated from EUT, the test system was pre-scanning tested based on the consideration of following EUT operation mode or test configuration mode which possible have effect on EMI emission level. Each of these EUT operation mode(s) or test configuration mode(s) mentioned above was evaluated respectively.

Pretest Mode	Description
Mode 1	TX Mode

For Conducted Test	
Final Test Mode	Description
Mode 1	TX Mode

For Radiated Test	
Final Test Mode	Description
Mode 1	TX Mode

3.3 BLOCK DIAGRAM SHOWING THE CONFIGURATION OF SYSTEM TESTED

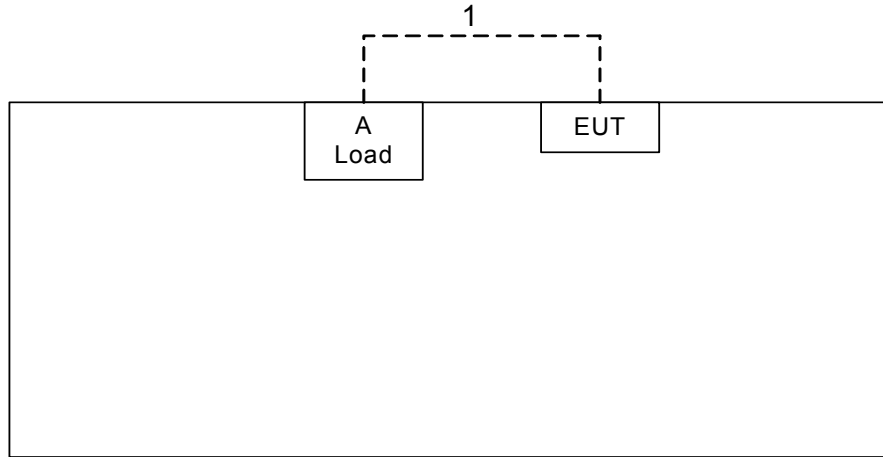

3.4 DESCRIPTION OF SUPPORT UNITS

The EUT has been tested as an independent unit together with other necessary accessories or support units. The following support units or accessories were used to form a representative test configuration during the tests.

Item	Equipment	Mfr/Brand	Model/Type No.	FCC ID	Series No.
A	Load	N/A	N/A	N/A	N/A

Item	Shielded Type	Ferrite Core	Length	Note
1	NO	NO	0.25m	Power Cable

4. EMC EMISSION TEST

4.1 CONDUCTED EMISSION MEASUREMENT

4.1.1 POWER LINE CONDUCTED EMISSION (FREQUENCY RANGE 150KHZ-30MHZ)

Frequency of Emission (MHz)	Conducted Limit (dB μ V)	
	Quasi-peak	Average
0.15 -0.5	66 to 56*	56 to 46*
0.50 -5.0	56	46
5.0 -30.0	60	50

Note:

- (1) The limit of " * " decreases with the logarithm of the frequency
- (2) The test result calculated as following:
 Measurement Value = Reading Level + Correct Factor
 Correct Factor = Insertion Loss + Cable Loss + Attenuator Factor(if use)
 Margin Level = Measurement Value - Limit Value

The following table is the setting of the receiver

Receiver Parameters	Setting
Attenuation	10 dB
Start Frequency	0.15 MHz
Stop Frequency	30 MHz
IF Bandwidth	9 kHz

4.1.2 TEST PROCEDURE

- a. The EUT was placed 0.8 meters from the horizontal ground plane with EUT being connected to the power mains through a line impedance stabilization network (LISN). All other support equipments powered from additional LISN(s). The LISN provide 50 Ohm/ 50uH of coupling impedance for the measuring instrument.
- b. Interconnecting cables that hang closer than 40 cm to the groundplane shall be folded back and forth in the center forming a bundle 30 to 40 cm long.
- c. I/O cables that are not connected to a peripheral shall be bundled in the center. The end of the cable may be terminated, if required, using the correct terminating impedance. The overall length shall not exceed 1 m.
- d. LISN at least 80 cm from nearest part of EUT chassis.
- e. For the actual test configuration, please refer to the related Item –EUT Test Photos.

4.1.3 DEVIATION FROM TEST STANDARD

No deviation

4.1.4 TEST SETUP

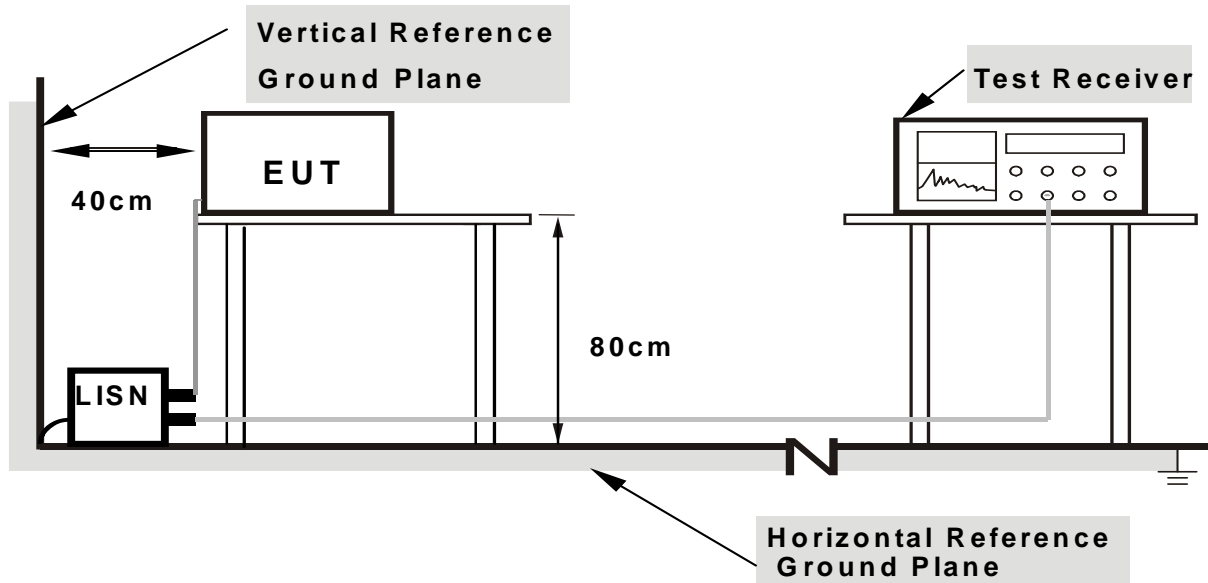

Note: 1. Support units were connected to second LISN.

2. Both of LISNs (AMN) are 80 cm from EUT and at least 80 from other units and other metal planes

4.1.5 EUT OPERATING CONDITIONS

The EUT was configured for testing in a typical fashion (as a customer would normally use it).

4.1.6 EUT TEST CONDITIONS

Temperature: 25°C

Relative Humidity: 56%

Test Voltage: AC 120V/60Hz

4.1.7 TEST RESULTS

Please refer to the Attachment A.

Remark:

- (1) All readings are QP Mode value unless otherwise stated AVG in column of 'Note'. If the QP Mode Measured value compliance with the QP Limits and lower than AVG Limits, the EUT shall be deemed to meet both QP & AVG Limits and then only QP Mode was measured, but AVG Mode didn't perform in this case, a "*" marked in AVG Mode column of Interference Voltage Measured.
- (2) Measuring frequency range from 150KHz to 30MHz.

4.2 RADIATED EMISSION MEASUREMENT

4.2.1 RADIATED EMISSION LIMITS (FCC 15.209)

Frequencies (MHz)	Field Strength (micorvolts/meter)	Measurement Distance (meters)
0.009~0.490	2400/F(KHz)	300
0.490~1.705	24000/F(KHz)	30
1.705~30.0	30	30
30~88	100	3
88~216	150	3
216~960	200	3
960~1000	500	3

Harmonic emissions limits comply with below 54 dBuV/m at 3m. Other emissions radiated outside of the specified frequency bands, except for harmonics, shall be attenuated by at least 50 dB below the level of the fundamental or comply with the radiated emissions limits specified in section 15.209(a) limit in the table below has to be followed.

Note:

- (1) The tighter limit applies at the band edges.
- (2) Emission level (dBuV/m)=20log Emission level (uV/m).

LIMITS OF RADIATED EMISSION MEASUREMENT (FCC 15.209)

FREQUENCY (MHz)	(dBuV/m) (at 3m)	
	PEAK	AVERAGE
Above 1000	74	54

Notes:

- (1) The limit for radiated test was performed according to FCC PART 15C.
- (2) The tighter limit applies at the band edges.
- (3) Emission level (dBuV/m)=20log Emission level (uV/m).

LIMITS OF RADIATED EMISSION MEASUREMENT (FCC Part 15.249)

FCC Part15 (15.249) , Subpart C	
Limit	Frequency Range(MHz)
Field strength of fundamental 50000 μ V/m (94 dB μ V/m) @ 3 m	2400-2483.5
Field strength of harmonics 500 μ V/m (54 dB μ V/m) @ 3 m	Above 2483.5

Spectrum Parameter	Setting
Attenuation	Auto
Start Frequency	1000 MHz
Stop Frequency	10th carrier harmonic

Receiver Parameter	Setting
Attenuation	Auto
Start ~ Stop Frequency	9kHz~90kHz for PK/AVG detector
Start ~ Stop Frequency	90kHz~110kHz for QP detector
Start ~ Stop Frequency	110kHz~490kHz for PK/AVG detector
Start ~ Stop Frequency	490kHz~30MHz for QP detector
Start ~ Stop Frequency	30MHz~1000MHz for QP detector

4.2.2 TESTPROCEDURE

- a. The measuring distance of 3 m shall be used for measurements. The EUT was placed on the top of a rotating table 0.8 meter above the ground at a 3 meter semi-anechoic chamber. The table was rotated 360 degrees to determine the position of the highest radiation.(below 1GHz)
- b. The measuring distance of 3 m shall be used for measurements. The EUT was placed on the top of a rotating table 1.5 meter above the ground at a 3 meter semi-anechoic chamber. The table was rotated 360 degrees to determine the position of the highest radiation.(above 1GHz)
- c. The height of the equipment or of the substitution antenna shall be 0.8 m or 1.5m, the height of the test antenna shall vary between 1 m to 4 m. Both horizontal and vertical polarizations of the antenna are set to make the measurement.
- d. The initial step in collecting radiated emission data is a receiver peak detector mode pre-scanning the measurement frequency range. Significant peaks are then marked and then Quasi Peak detector mode re-measured.
- e. All readings are Peak unless otherwise stated QP in column of Note. Peak denotes that the Peak reading compliance with the QP Limits and then QP Mode measurement didn't perform. (below 1GHz)
- f. All readings are Peak Mode value unless otherwise stated AVG in column of Note. If the Peak Mode Measured value compliance with the Peak Limits and lower than AVG Limits, the EUT shall be deemed to meet both Peak & AVG Limits and then only Peak Mode was measured, but AVG Mode didn't perform. (above 1GHz)
- g. For the actual test configuration, please refer to the related Item –EUT Test Photos.

4.2.3 DEVIATION FROM TEST STANDARD

No deviation

4.2.4 TESTSETUP

(A) Radiated Emission Test Set-Up Frequency Below 1 GHz

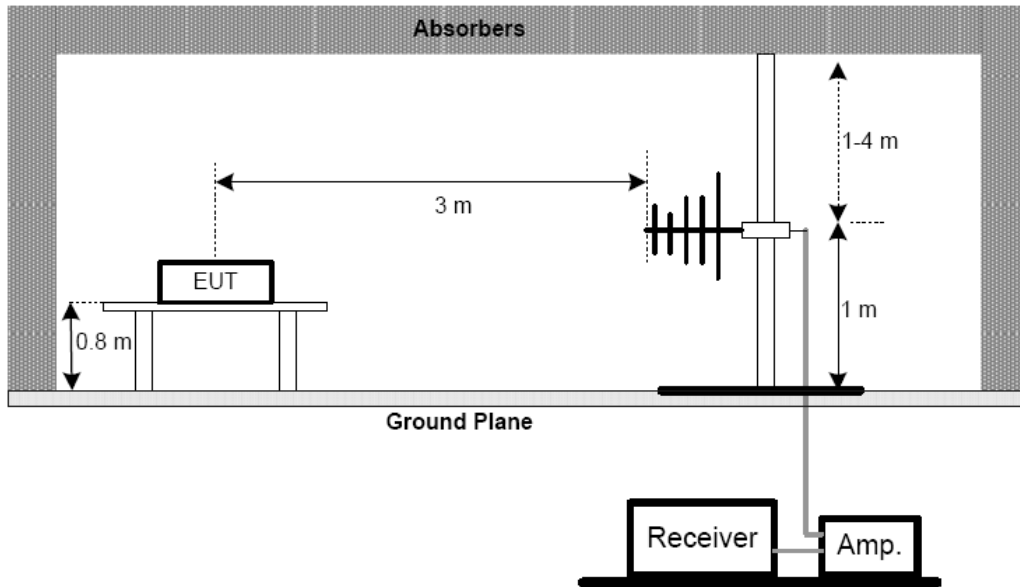

(B) Radiated Emission Test Set-Up Frequency Above 1 GHz

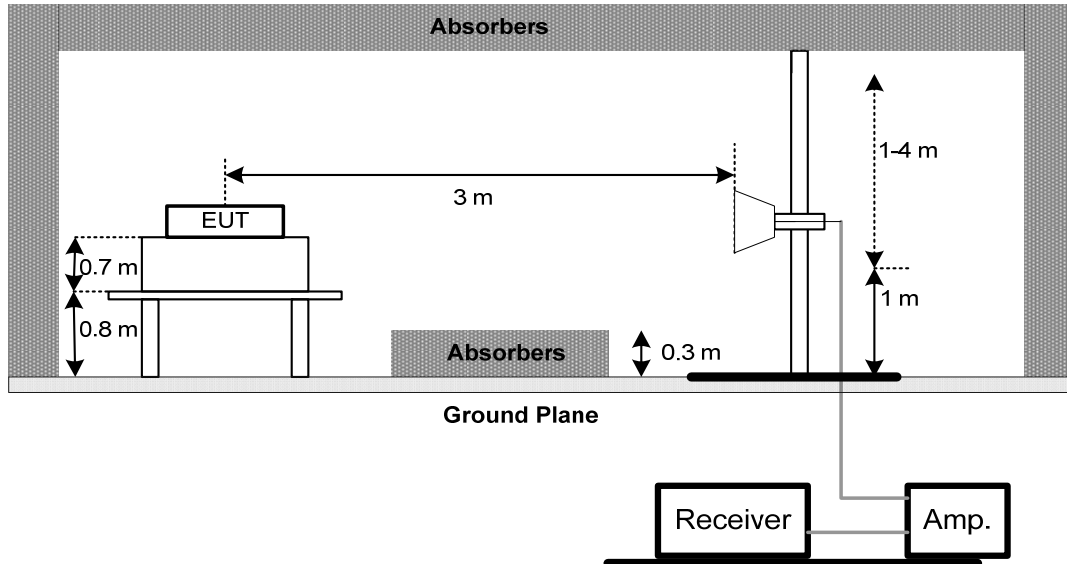

(C) For radiated emissions below 30MHz

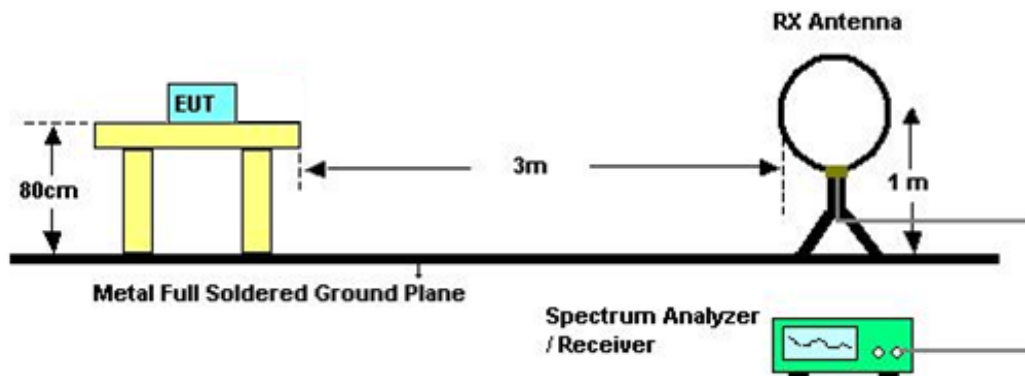

4.2.5 EUT OPERATING CONDITIONS

The EUT was programmed to be in continuously transmitting mode.

4.2.6 EUT TEST CONDITIONS

Temperature: 26°C

Relative Humidity: 61%

Test Voltage: AC 120V 60Hz

4.2.7 TEST RESULTS (9KHZ 30MHZ)

Please refer to the Attachment B.

Remark:

- (1) The amplitude of spurious emissions which are attenuated by more than 20 dB below the permissible value has no need to be reported.
- (2) Distance extrapolation factor = $40 \log(\text{specific distance} / \text{test distance})$ (dB);.
- (3) Limit line = specific limits (dBuV) + distance extrapolation factor..

4.2.8 TEST RESULTS (30MHZ to 1000 MHZ)

Please refer to the Attachment C

Remark:

- (1) All readings are Peak unless otherwise stated QP in column of 『Note』 . Peak denotes that the Peak reading compliance with the QP Limits and then QP Mode measurement didn't perform.
- (2) Measuring frequency range from 30MHz to 1000MHz or the 10th harmonic of highest fundamental frequency. "F" denotes fundamental frequency; "H" denotes spurious frequency. "E" denotes band edge frequency.
- (3) Radiated emissions measured in frequency range from 30 MHz to 1000 MHz were made with an instrument using Peak detector mode or QP detector mode of the emission .

4.2.9 TEST RESULTS (ABOVE 1000 MHZ)

Please refer to the Attachment D

Remark:

- (1) All readings are Peak unless otherwise stated QP in column of 『Note』 . Peak denotes that the Peak reading compliance with the QP Limits and then QP Mode measurement didn't perform.
- (2) Radiated emissions measured in frequency range above 1000MHz were made with an instrument using Peak detector mode and AV detector mode of the emission .
- (3) Data of measurement within this frequency range shown “ * ” in the table above means the reading of emissions are attenuated more than 20dB below the permissible limits or the field strength is too small to be measured.
- (4) A preamp and high pass filter were used for this test in order to provide sufficient measurement sensitivity.
- (5) EUT Orthogonal Axis:
“X” - denotes Laid on Table; “Y” - denotes Vertical Stand; “Z” - denotes Side Stand
- (6) During the measurements above 1 GHz it is taken care of that the EUT is always within the 3 dB cone of radiation BW of the used antenna
- (7) No limit: This is fundamental signal, the judgment is not applicable.
For fundamental signal judgment was referred to Peak output test.

5. BANDWIDTH TEST

5.1 TEST PROCEDURE

- a. The EUT was directly connected to the spectrum analyzer and antenna output port as show in the block diagram below,
- b. Spectrum Setting: RBW= 100KHz, VBW=300KHz, Sweep time = Auto.

5.2 DEVIATION FROM STANDARD

No deviation.

5.3 TEST SETUP



5.4 EUT OPERATION CONDITIONS

The EUT was programmed to be in continuously transmitting mode.

5.5 EUT TEST CONDITIONS

Temperature: 26°C
Relative Humidity: 61%
Test Voltage: AC 120V 60Hz

5.6 TEST RESULTS

Please refer to the Attachment E

6. MEASUREMENT INSTRUMENTS LIST AND SETTING

Conducted Emission Measurement					
Item	Kind of Equipment	Manufacturer	Type No.	Serial No.	Calibrated until
1	LISN	R&S	ENV216	101050	Nov. 24, 2015
2	Test Cable	TIMES	CFD300-NL	C05	Jun. 16, 2016
3	EMI Test Receiver	R&S	ESCI	100082	Apr. 14, 2016
4	Measurement Software	EZ	EZ EMC (Version NB-02A)	N/A	N/A

Radiated Emission Measurement					
Item	Kind of Equipment	Manufacturer	Type No.	Serial No.	Calibrated until
1	Spectrum Analyzer	R&S	FSP-40	100129	Jan.07, 2016
2	Horn Antenna	Schwarzbeck	BBHA 9120	D-325	Jun. 15, 2016
3	Microwave Pre_amplifier	Agilent	8449B	3008A01714	Apr. 16, 2016
4	Microflex Cable	Harbour industries	27478LL142	1m	May 13, 2016
5	Microflex Cable	EMC	S104-SMA	8m	May 15, 2016
6	Microflex Cable	Harbour industries	27478LL142	3m	May 13, 2016
7	Test Cable	LMR	LMR-400	12m	May 14, 2016
8	Test Cable	LMR	LMR-400	3m	May 14, 2016
9	Pre-Amplifier	Anritsu	MH648A	M92649	Jun. 17, 2016
10	Log-Bicon Antenna	Schwarzbeck	VULB9168-35 2	9168-352	Jul. 31, 2016
11	Loop Antenna	EMCO	6502	00042960	Nov. 08, 2015

Bandwidth					
Item	Kind of Equipment	Manufacturer	Type No.	Serial No.	Calibrated until
1	Spectrum Analyzer	R&S	FSP-40	100129	Jan.07, 2016

Remark: "N/A" denotes no model name, serial no. or calibration specified.
All calibration period of equipment list is one year.

7. EUT TEST PHOTO

Conducted Measurement Photos-LR7A-M13

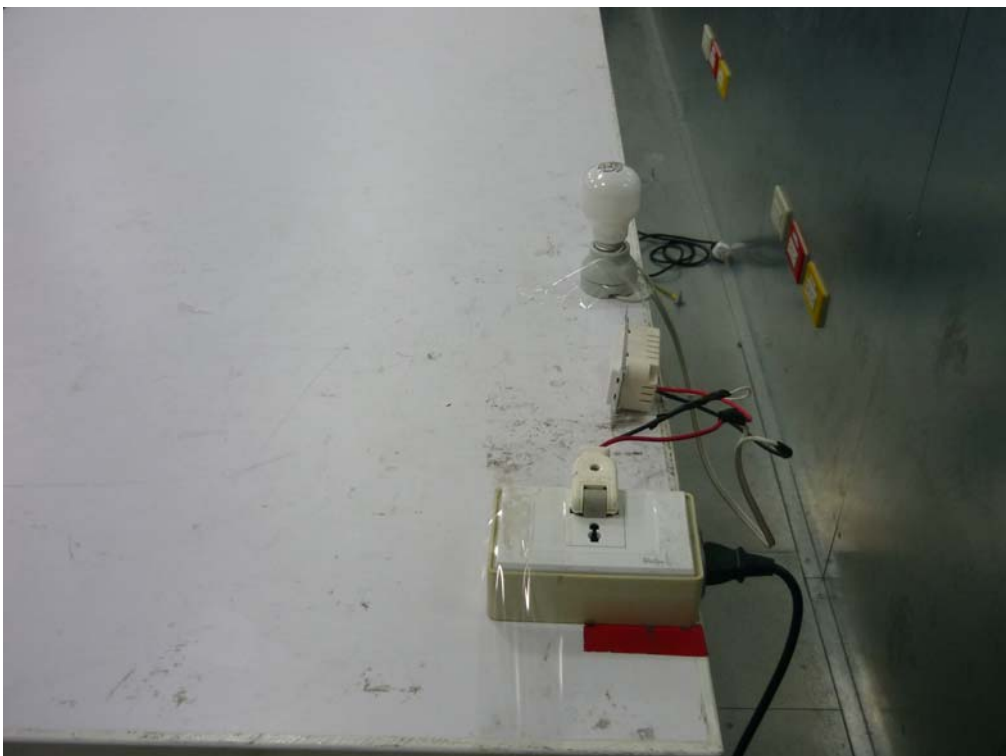

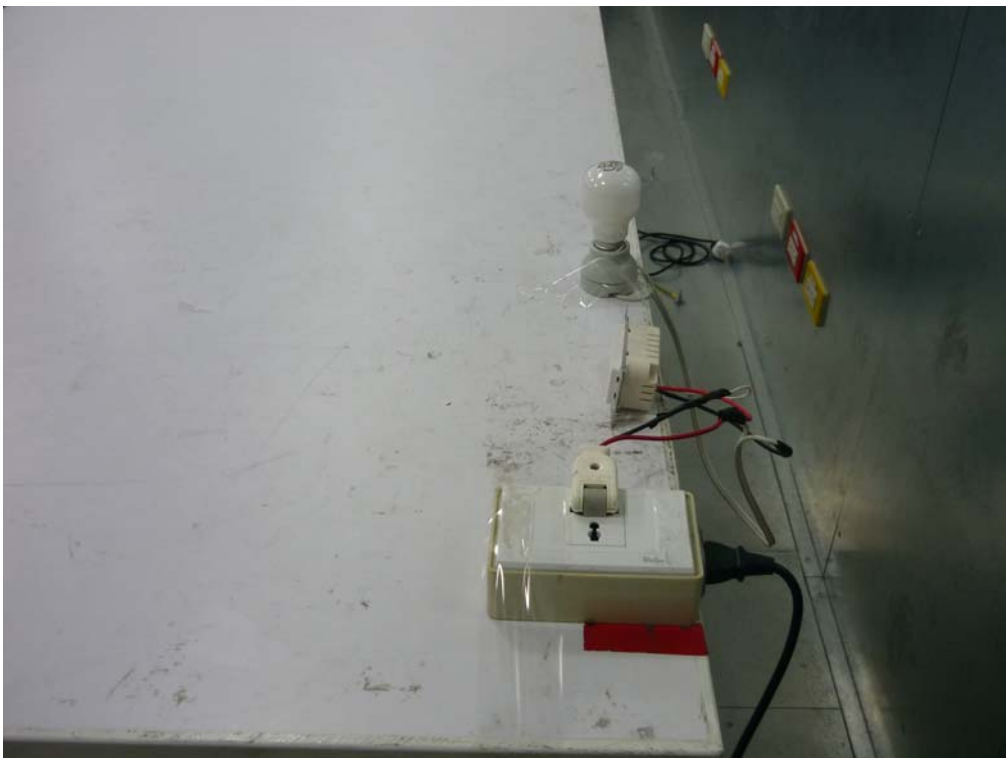
Conducted Measurement Photos-LR3A-M13

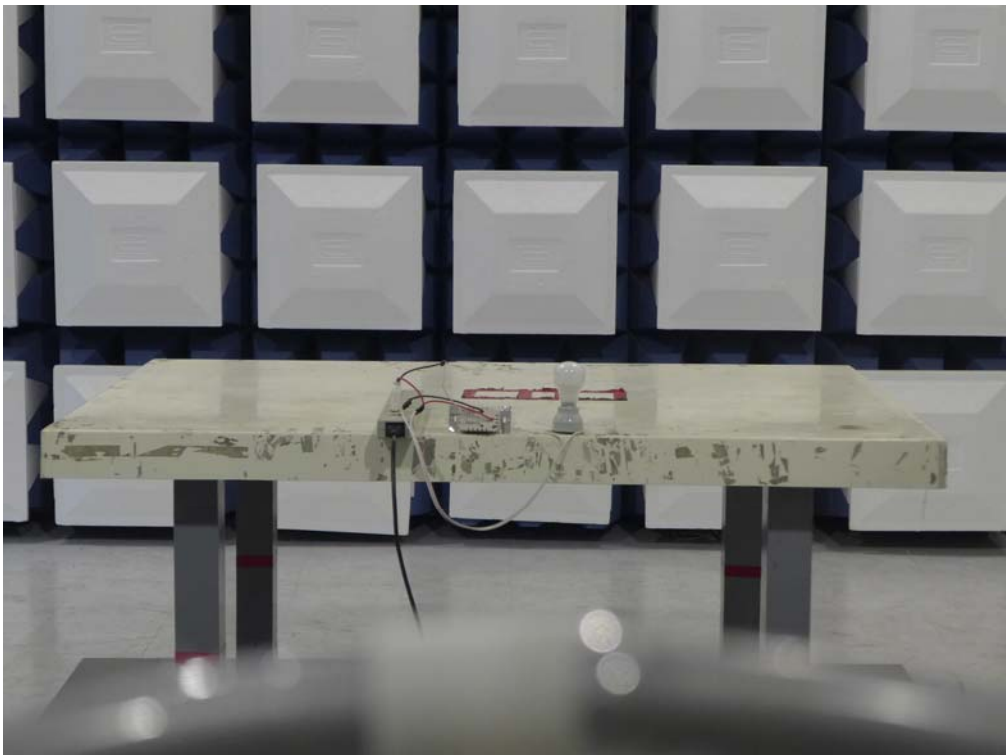
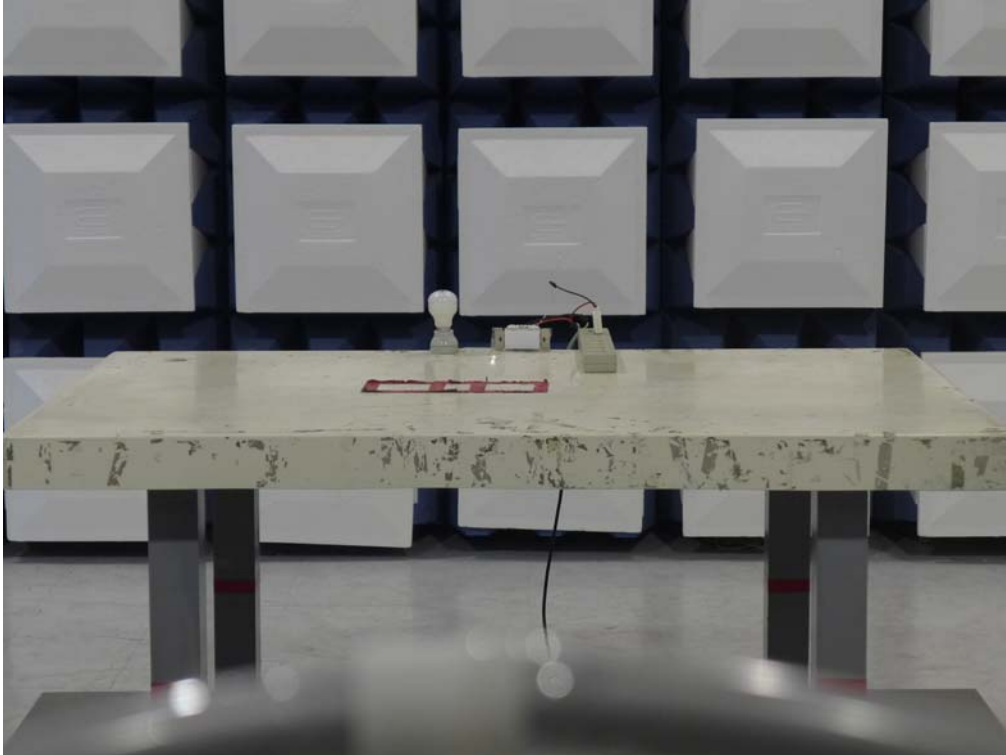
Radiated Measurement Photos-LR7A-M13**9KHz to 30MHz**

Radiated Measurement Photos-LR3A-M13

9KHz to 30MHz

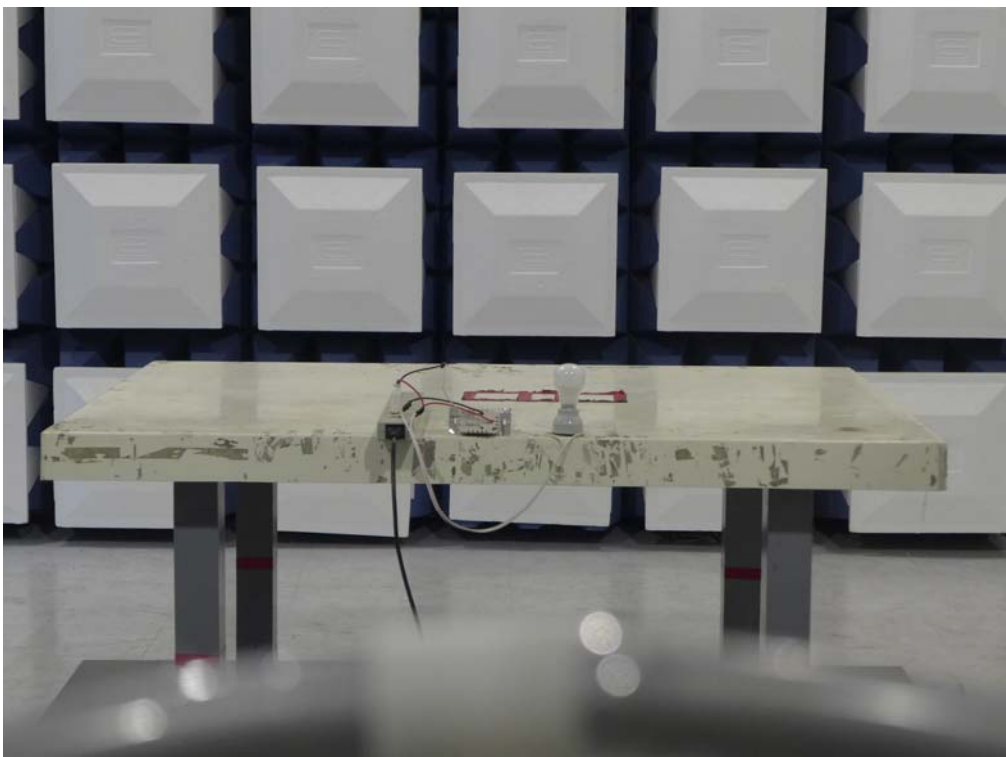
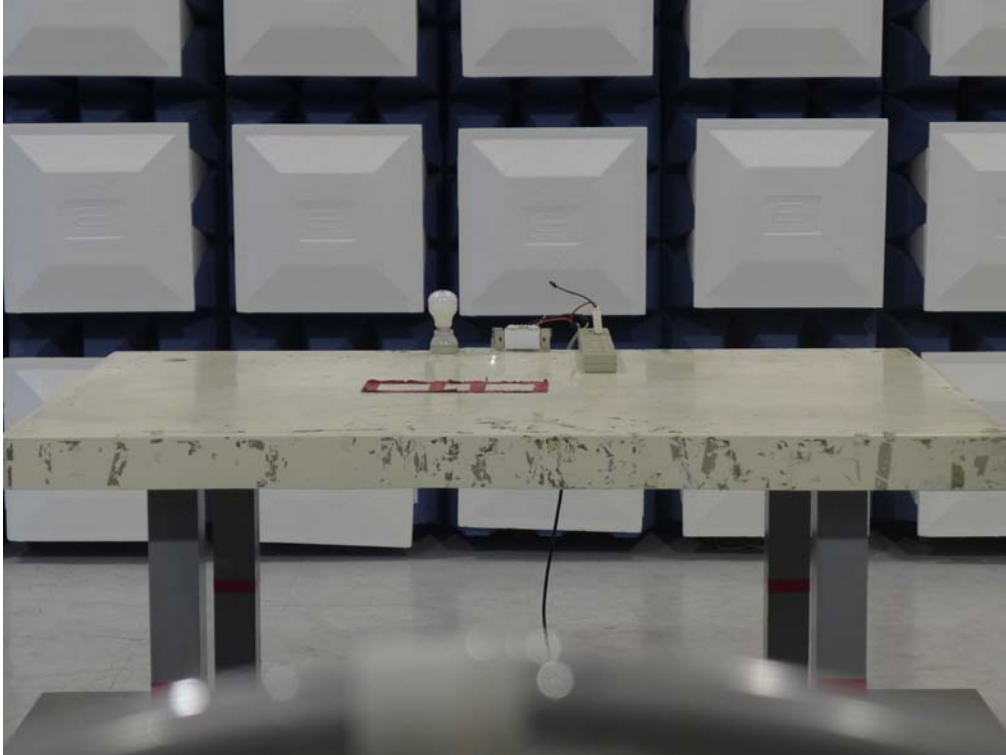

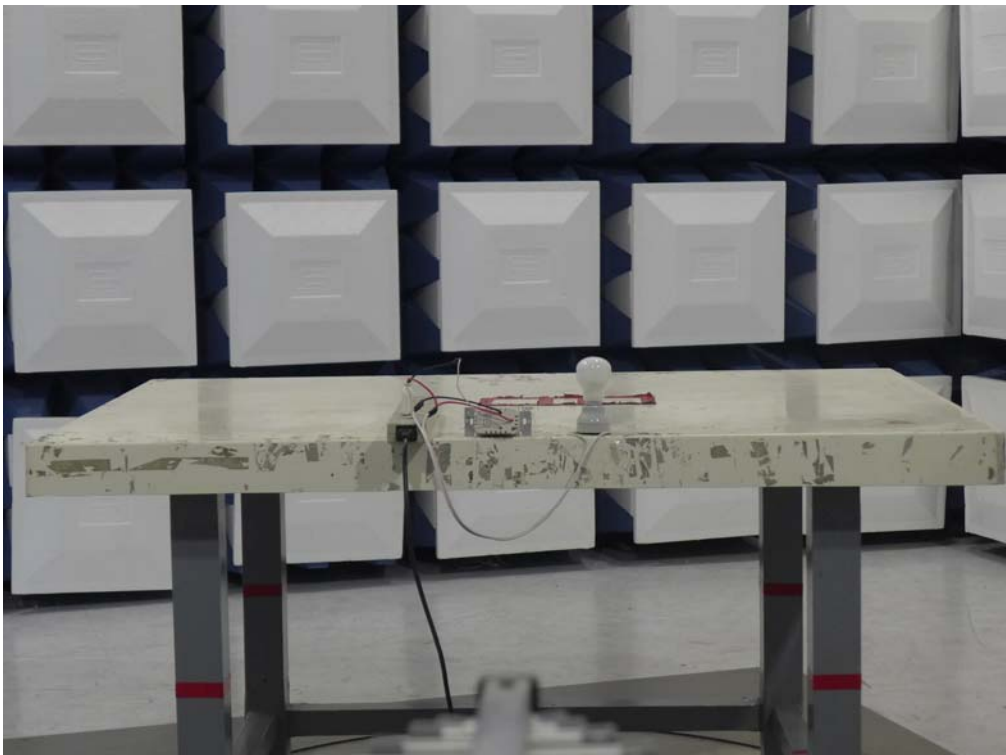
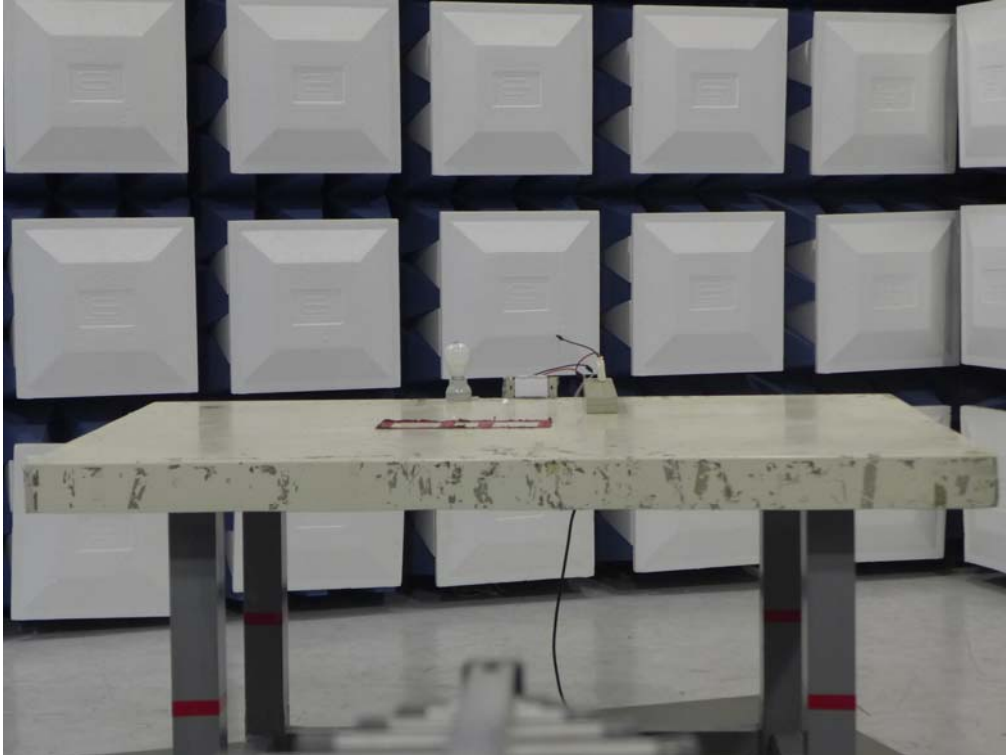
Radiated Measurement Photos-LR7A-M13**30MHz to 1000MHz**

Radiated Measurement Photos-LR3A-M13

30MHz to 1000MHz

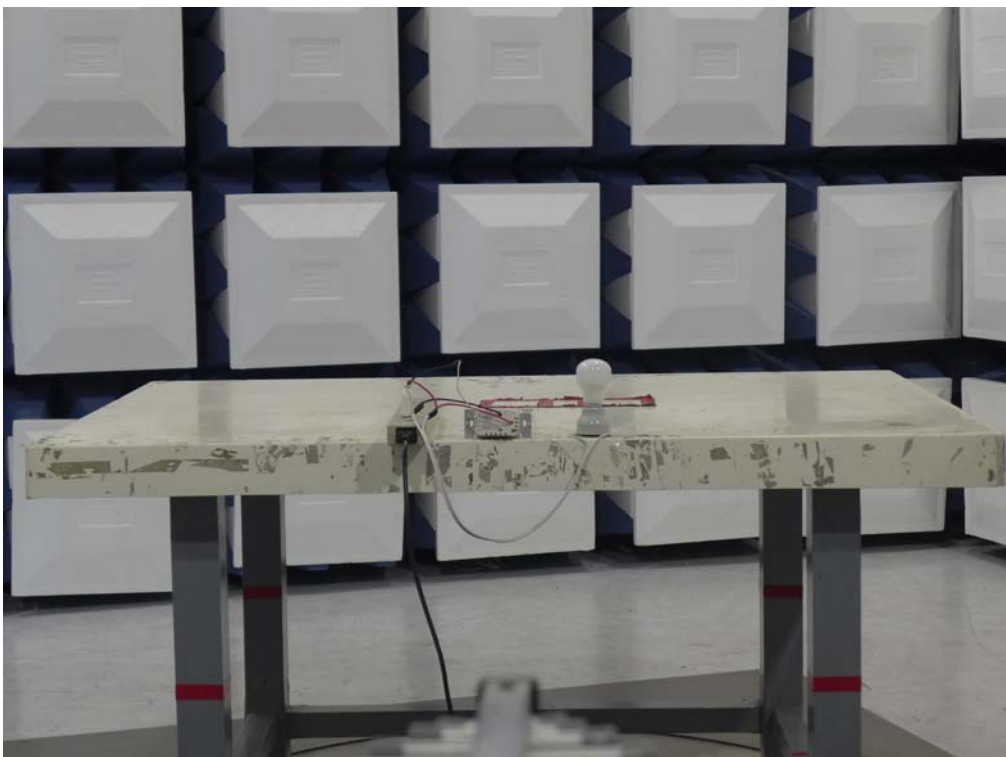
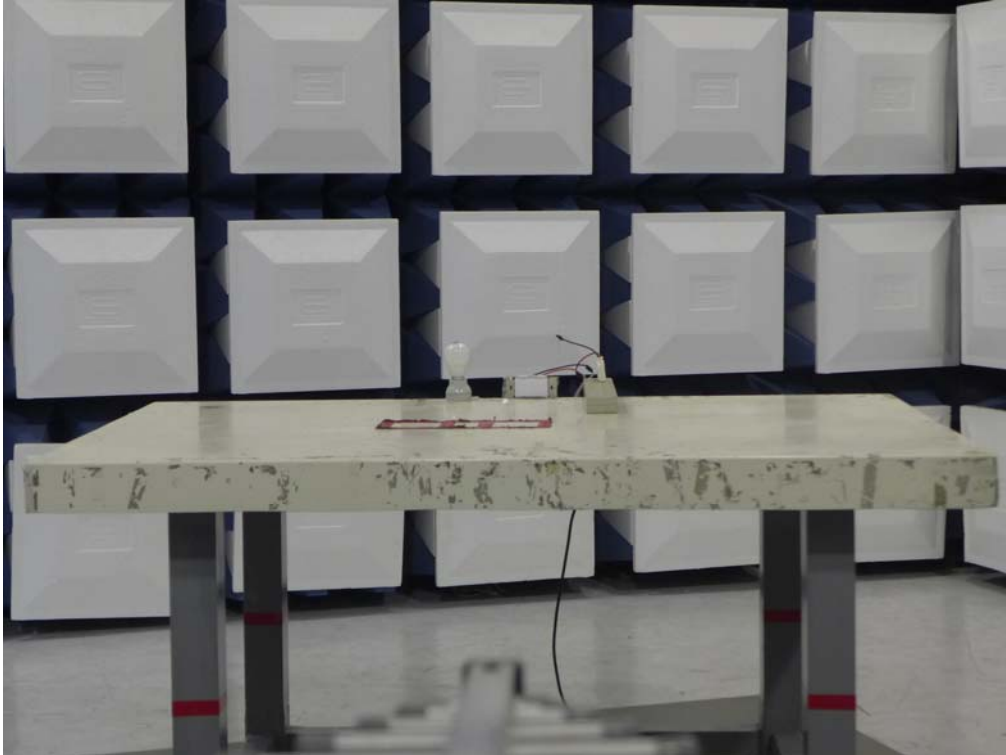

Radiated Measurement Photos-LR7A-M13

Above 1000MHz

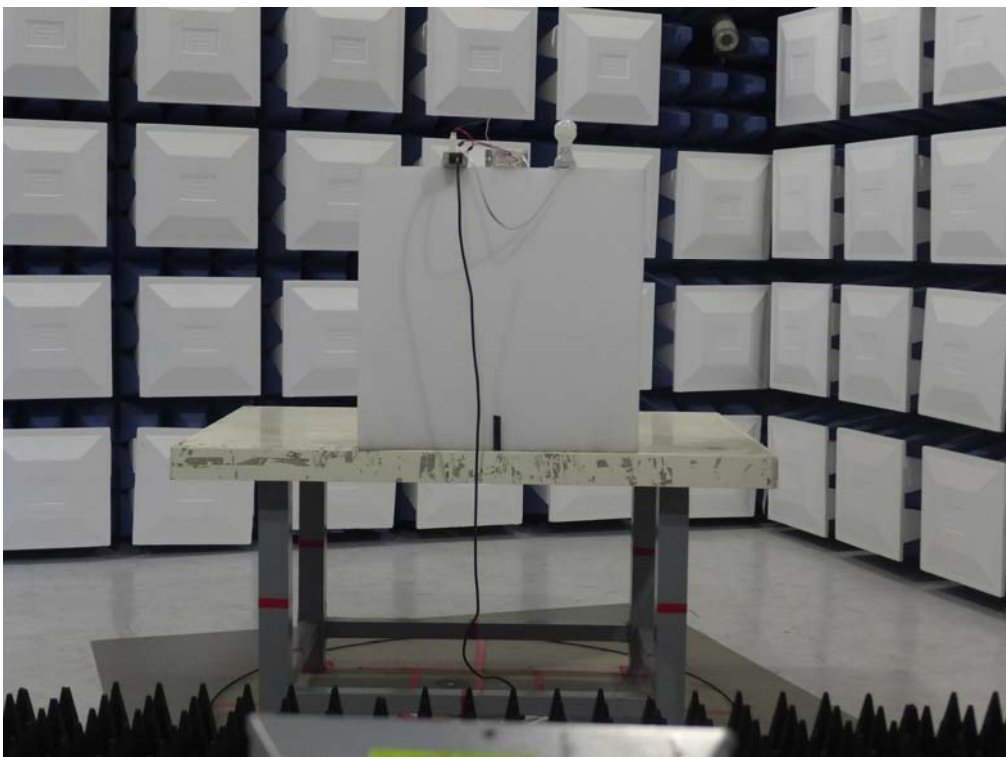
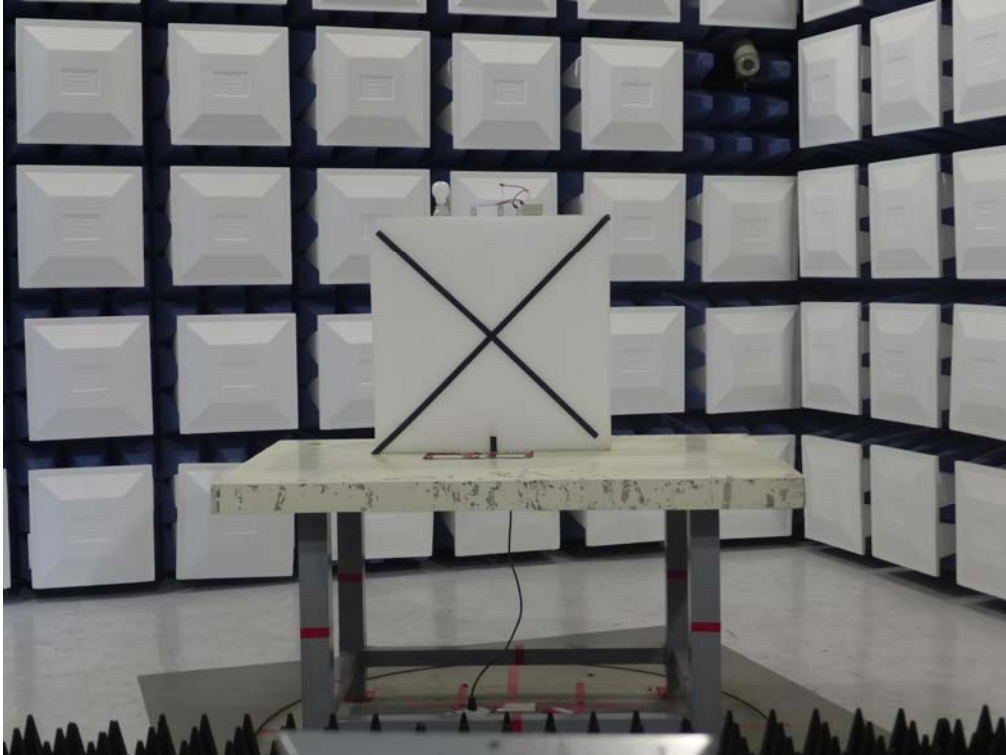

Radiated Measurement Photos-LR3A-M13

Above 1000MHz

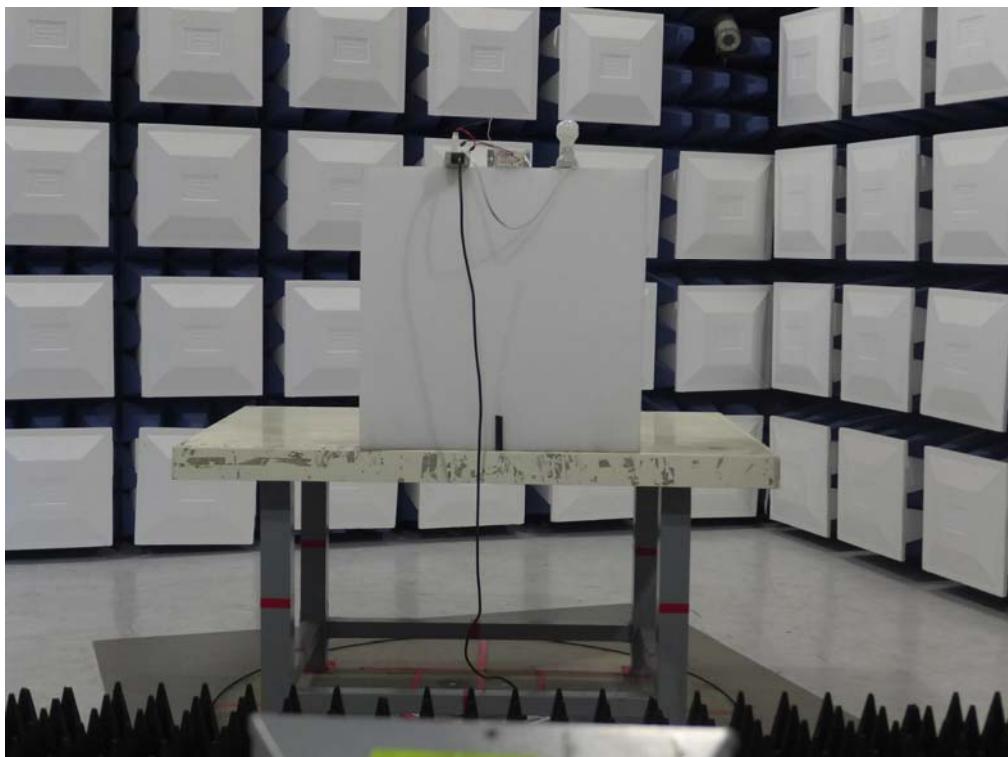

ATTACHMENT A - CONDUCTED EMISSION

Test Mode: TX Mode- Model: LR7A-M13

Line

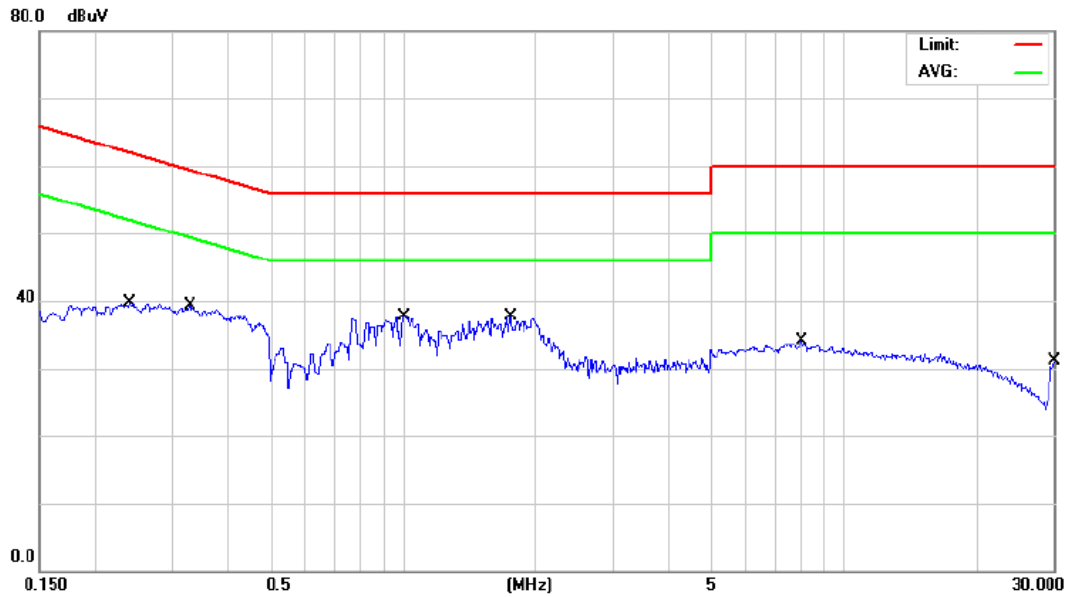

No.	Mk.	Freq. MHz	Reading Level dBuV	Correct Factor dB	Measure- ment dBuV	Limit dBuV	Margin dB	Detector	Comment
1		0.2396	24.40	9.63	34.03	62.11	-28.08	QP	
2		0.2396	7.00	9.63	16.63	52.11	-35.48	AVG	
3		0.3271	24.00	9.63	33.63	59.52	-25.89	QP	
4		0.3271	6.60	9.63	16.23	49.52	-33.29	AVG	
5	*	1.0040	24.00	9.67	33.67	56.00	-22.33	QP	
6		1.0040	6.60	9.67	16.27	46.00	-29.73	AVG	
7		1.7510	23.00	9.72	32.72	56.00	-23.28	QP	
8		1.7510	6.90	9.72	16.62	46.00	-29.38	AVG	
9		8.0000	17.10	9.90	27.00	60.00	-33.00	QP	
10		8.0000	8.60	9.90	18.50	50.00	-31.50	AVG	
11		30.0000	13.30	9.86	23.16	60.00	-36.84	QP	
12		30.0000	9.80	9.86	19.66	50.00	-30.34	AVG	

Test Mode: TX Mode- Model: LR7A-M13

Neutral

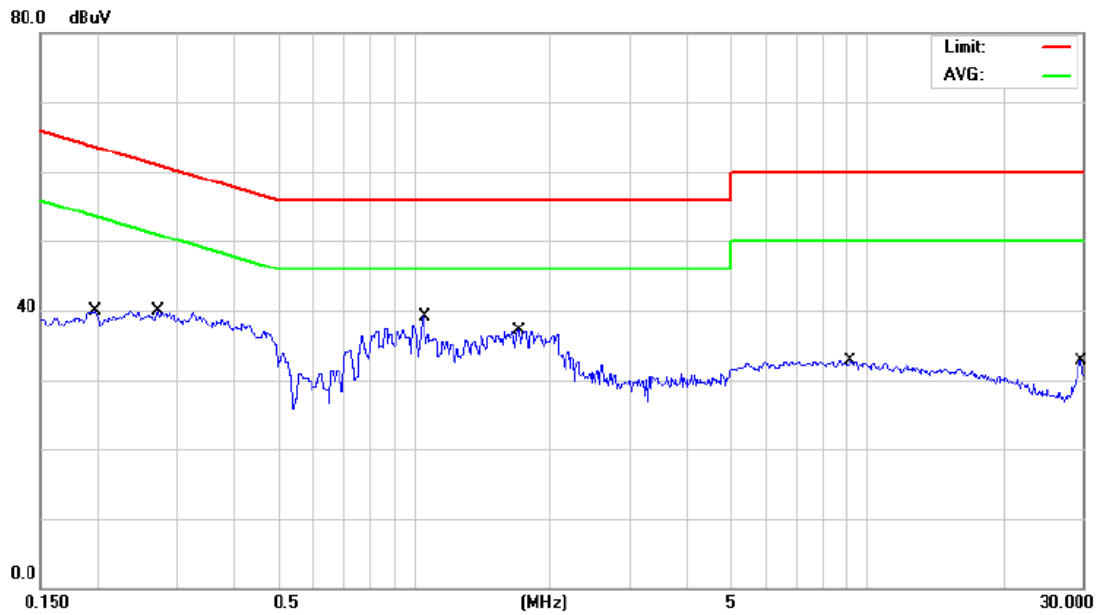

No. Mk.	Freq. MHz	Reading Level dBuV	Correct Factor dB	Measure- ment dBuV	Limit dBuV	Margin dB	Detector	Comment
1	0.1976	24.10	9.63	33.73	63.71	-29.98	QP	
2	0.1976	8.50	9.63	18.13	53.71	-35.58	AVG	
3	0.2711	24.70	9.63	34.33	61.08	-26.75	QP	
4	0.2711	9.40	9.63	19.03	51.08	-32.05	AVG	
5 *	1.0490	24.40	9.67	34.07	56.00	-21.93	QP	
6	1.0490	10.30	9.67	19.97	46.00	-26.03	AVG	
7	1.7060	23.40	9.71	33.11	56.00	-22.89	QP	
8	1.7060	7.30	9.71	17.01	46.00	-28.99	AVG	
9	9.2000	16.30	9.91	26.21	60.00	-33.79	QP	
10	9.2000	5.40	9.91	15.31	50.00	-34.69	AVG	
11	29.6000	10.50	9.91	20.41	60.00	-39.59	QP	
12	29.6000	10.80	9.91	20.71	50.00	-29.29	AVG	

Test Mode: TX Mode-Model: LR3A-M13

Line

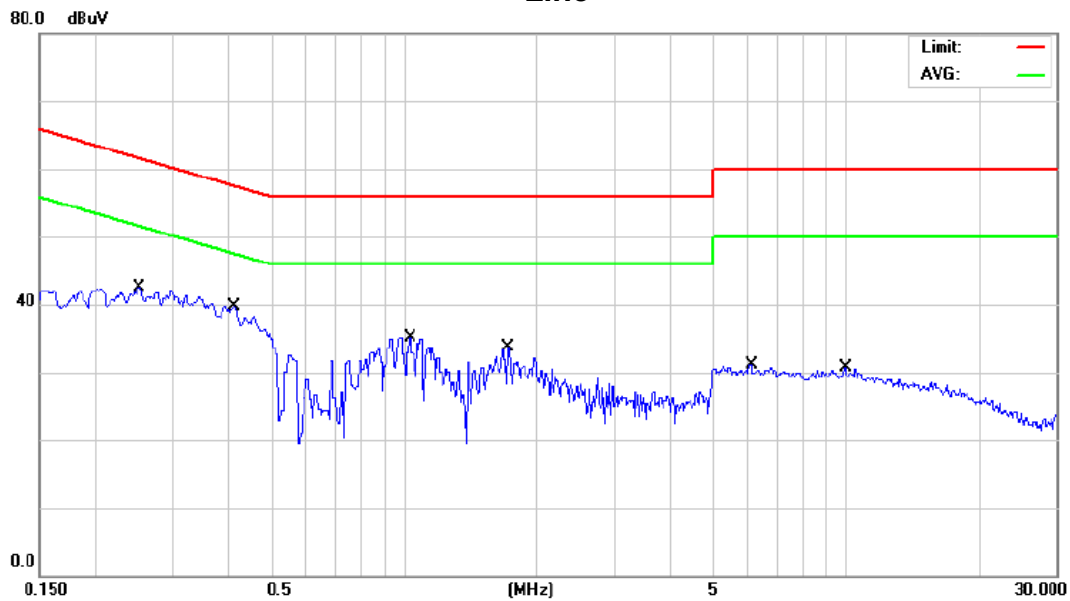

No.	Mk.	Freq. MHz	Reading Level dBuV	Correct Factor dB	Measure- ment dBuV	Limit dBuV	Margin dB	Detector	Comment
1		0.2515	27.00	9.63	36.63	61.70	-25.07	QP	
2		0.2515	9.90	9.63	19.53	51.70	-32.17	AVG	
3	*	0.4118	24.60	9.63	34.23	57.61	-23.38	QP	
4		0.4118	9.50	9.63	19.13	47.61	-28.48	AVG	
5		1.0310	21.40	9.67	31.07	56.00	-24.93	QP	
6		1.0310	8.60	9.67	18.27	46.00	-27.73	AVG	
7		1.7240	17.40	9.72	27.12	56.00	-28.88	QP	
8		1.7240	5.10	9.72	14.82	46.00	-31.18	AVG	
9		6.1000	11.20	9.87	21.07	60.00	-38.93	QP	
10		6.1000	4.10	9.87	13.97	50.00	-36.03	AVG	
11		9.9500	14.80	9.92	24.72	60.00	-35.28	QP	
12		9.9500	6.40	9.92	16.32	50.00	-33.68	AVG	

Test Mode: TX Mode- Model: LR3A-M13

Neutral

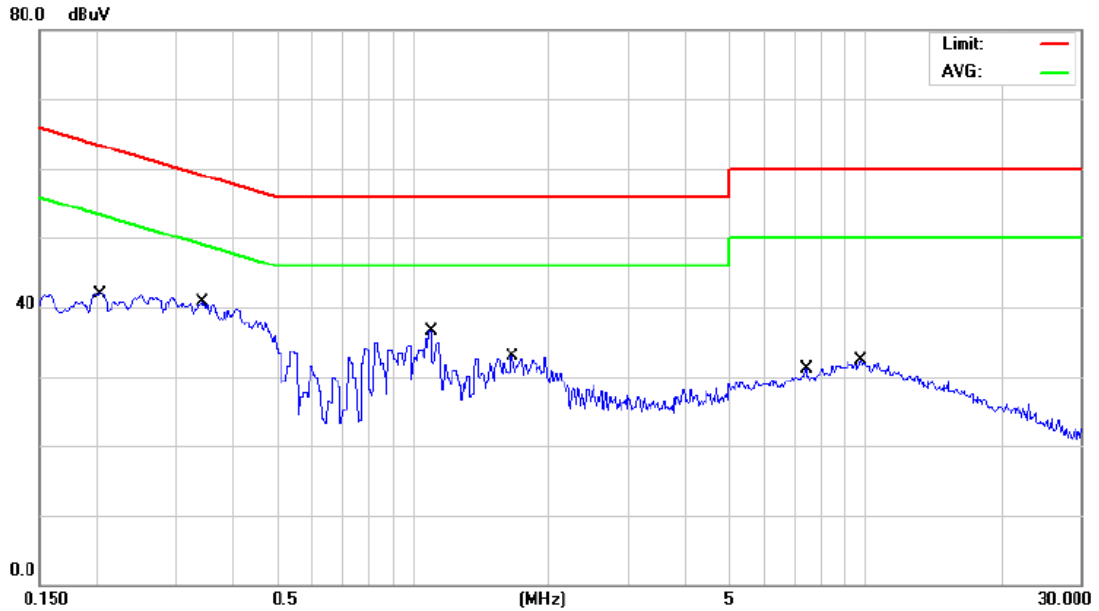

No.	Mk.	Freq. MHz	Reading Level dBuV	Correct Factor dB	Measure- ment dBuV	Limit dBuV	Margin dB	Detector	Comment
1		0.2039	28.10	9.63	37.73	63.45	-25.72	QP	
2		0.2039	9.30	9.63	18.93	53.45	-34.52	AVG	
3	*	0.3446	26.10	9.64	35.74	59.09	-23.35	QP	
4		0.3446	7.10	9.64	16.74	49.09	-32.35	AVG	
5		1.0940	21.60	9.67	31.27	56.00	-24.73	QP	
6		1.0940	3.90	9.67	13.57	46.00	-32.43	AVG	
7		1.6610	18.70	9.70	28.40	56.00	-27.60	QP	
8		1.6610	4.10	9.70	13.80	46.00	-32.20	AVG	
9		7.4000	14.00	9.88	23.88	60.00	-36.12	QP	
10		7.4000	8.00	9.88	17.88	50.00	-32.12	AVG	
11		9.8000	15.40	9.92	25.32	60.00	-34.68	QP	
12		9.8000	9.90	9.92	19.82	50.00	-30.18	AVG	

ATTACHMENT B -RADIATED EMISSION (9KHZ to 30MHZ)

Test Mode:	TX Mode-Model: LR7A-M13
------------	-------------------------

Frequency (MHz)	Ant 0°/90°	Read level dBuV/m	Factor (dB)	Measured(FS) (dBuV/m)	Limit (dBuV/m)	Margin (dB)	Note
0.0164	0°	33.52	22.24	55.76	103.31	-47.55	AVG
0.0164	0°	43.59	22.24	65.83	123.31	-57.48	PK
0.0259	0°	28.51	22.00	50.51	99.34	-48.83	AVG
0.0259	0°	34.52	22.00	56.52	119.34	-62.82	PK
0.0410	0°	25.72	21.63	47.35	95.35	-48.00	AVG
0.0410	0°	33.26	21.63	54.89	115.35	-60.46	PK
0.0560	0°	24.21	21.30	45.51	92.64	-47.13	AVG
0.0560	0°	33.40	21.30	54.70	112.64	-57.94	PK
1.1630	0°	33.61	20.44	54.05	66.29	-12.25	QP
1.3690	0°	36.37	20.23	56.60	64.88	-8.28	QP

Frequency (MHz)	Ant 0°/90°	Read level dBuV/m	Factor (dB)	Measured(FS) (dBuV/m)	Limit (dBuV/m)	Margin (dB)	Note
0.0166	90°	31.48	22.24	53.72	103.20	-49.49	AVG
0.0166	90°	47.42	22.24	69.66	123.20	-53.55	PK
0.0270	90°	28.49	21.98	50.47	98.98	-48.51	AVG
0.0270	90°	43.63	21.98	65.61	118.98	-53.37	PK
0.0390	90°	25.58	21.68	47.26	95.78	-48.53	AVG
0.0390	90°	34.56	21.68	56.24	115.78	-59.55	PK
0.0570	90°	24.30	21.29	45.59	92.49	-46.90	AVG
0.0570	90°	37.57	21.29	58.86	112.49	-53.63	PK
1.1640	90°	34.95	20.44	55.39	66.29	-10.90	QP
1.2980	90°	32.58	20.30	52.88	65.34	-12.46	QP

Test Mode:	TX Mode-Model: LR3A-M13
------------	-------------------------

Frequency (MHz)	Ant 0°/90°	Read level dBuV/m	Factor (dB)	Measured(FS) (dBuV/m)	Limit (dBuV/m)	Margin (dB)	Note
0.0158	0°	34.53	22.26	56.79	103.63	-46.85	AVG
0.0158	0°	46.95	22.26	69.21	123.63	-54.43	PK
0.0265	0°	26.44	21.99	48.43	99.14	-50.71	AVG
0.0265	0°	35.62	21.99	57.61	119.14	-61.53	PK
0.0334	0°	25.60	21.82	47.42	97.13	-49.71	AVG
0.0334	0°	35.97	21.82	57.79	117.13	-59.34	PK
0.0560	0°	23.86	21.30	45.16	92.64	-47.48	AVG
0.0560	0°	33.57	21.30	54.87	112.64	-57.77	PK
1.2940	0°	31.47	20.31	51.78	65.37	-13.59	QP
1.3520	0°	37.65	20.25	57.90	64.98	-7.09	QP

Frequency (MHz)	Ant 0°/90°	Read level dBuV/m	Factor (dB)	Measured(FS) (dBuV/m)	Limit (dBuV/m)	Margin (dB)	Note
0.0160	90°	31.47	22.25	53.72	103.52	-49.80	AVG
0.0160	90°	47.36	22.25	69.61	123.52	-53.91	PK
0.0230	90°	28.85	22.08	50.93	100.37	-49.44	AVG
0.0230	90°	45.47	22.08	67.55	120.37	-52.82	PK
0.0430	90°	34.81	21.58	56.39	94.93	-38.55	AVG
0.0430	90°	35.85	21.58	57.43	114.93	-57.51	PK
0.0511	90°	24.05	21.38	45.43	93.44	-48.00	AVG
0.0511	90°	37.26	21.38	58.64	113.44	-54.79	PK
1.3100	90°	34.43	20.29	54.72	65.26	-10.54	QP
1.3550	90°	34.09	20.25	54.34	64.97	-10.63	QP

ATTACHMENT C -RADIATED EMISSION (30MHZ TO 1000MHZ)

Test Mode: TX Mode-Model: LR7A-M13

Vertical

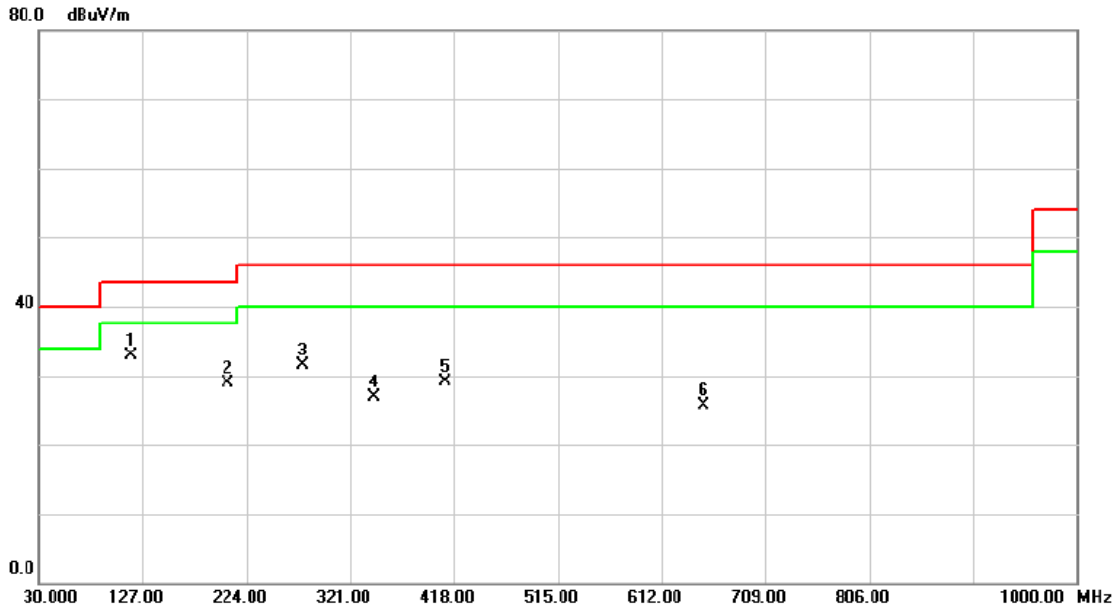

No.	Mk.	Freq. MHz	Reading Level dBuV	Correct Factor dB	Measure- ment dBuV/m	Limit dBuV/m	Margin dB	Detector	Comment
1	*	116.3300	47.28	-14.32	32.96	43.50	-10.54	peak	
2		206.5400	43.91	-14.96	28.95	43.50	-14.55	peak	
3		276.3800	43.58	-12.17	31.41	46.00	-14.59	peak	
4		343.3100	37.34	-10.52	26.82	46.00	-19.18	peak	
5		409.2700	38.69	-9.61	29.08	46.00	-16.92	peak	
6		651.7700	31.17	-5.53	25.64	46.00	-20.36	peak	

Test Mode: TX Mode-Model: LR7A-M13

Horizontal

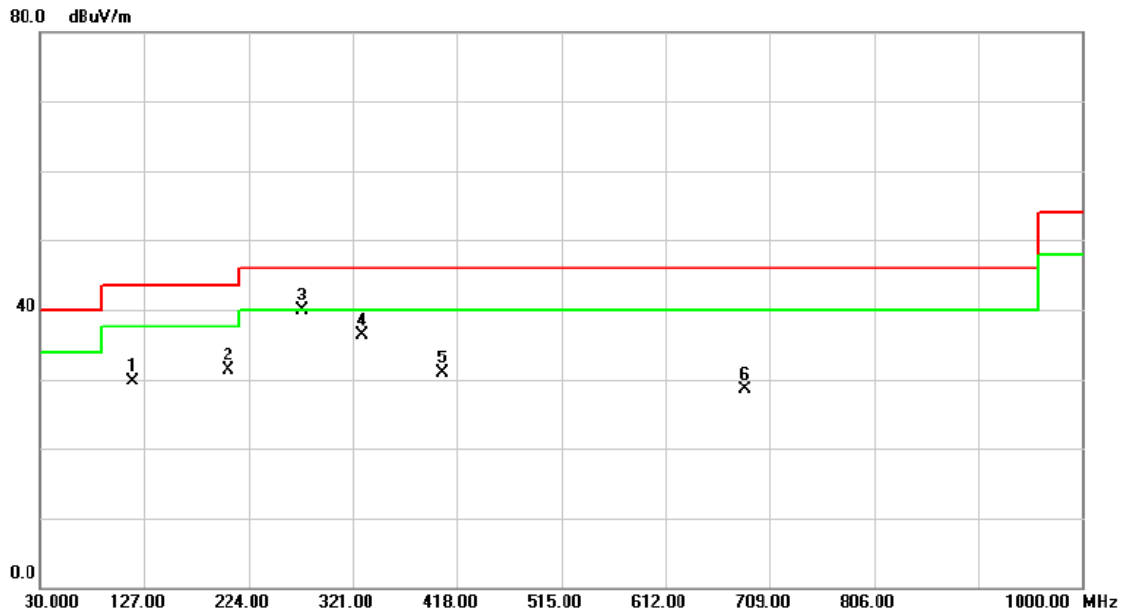

No. Mk.	Freq. MHz	Reading Level dBuV	Correct Factor dB	Measure- ment dBuV/m	Limit dBuV/m	Margin dB	Detector	Comment
1	116.3300	43.98	-14.32	29.66	43.50	-13.84	peak	
2	205.5700	46.39	-15.00	31.39	43.50	-12.11	peak	
3 *	273.4700	52.11	-12.27	39.84	46.00	-6.16	peak	
4	329.7300	47.07	-10.80	36.27	46.00	-9.73	peak	
5	404.4200	40.54	-9.67	30.87	46.00	-15.13	peak	
6	686.6900	33.24	-4.79	28.45	46.00	-17.55	peak	

Test Mode: TX Mode-Model: LR3A-M13

Vertical

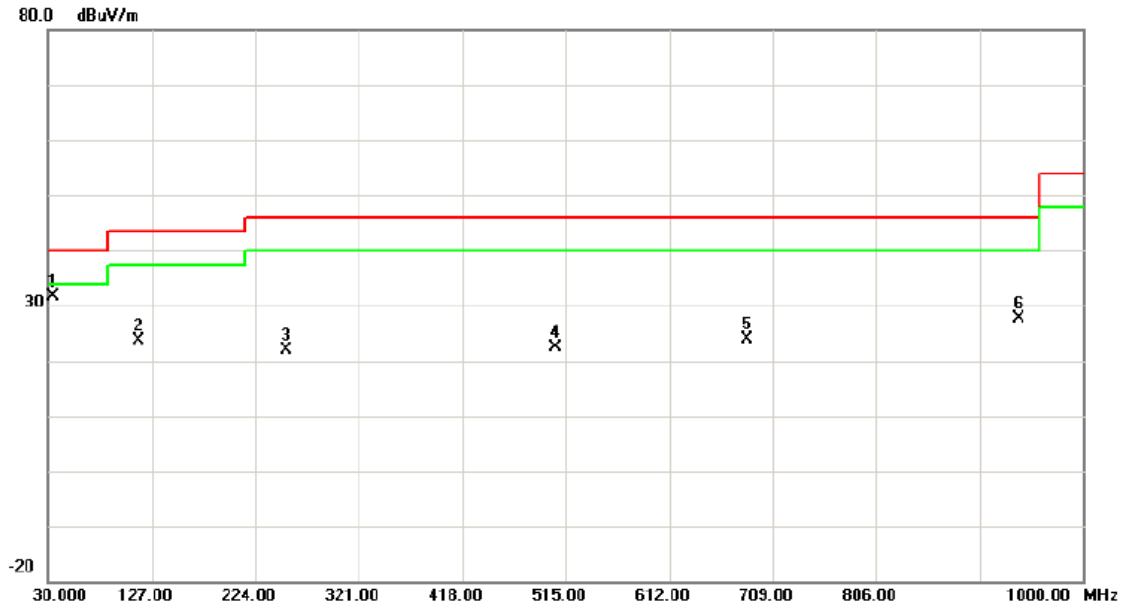

No.	Mk.	Freq. MHz	Reading Level dBuV	Correct Factor dB	Measure- ment dBuV/m	Limit dBuV/m	Margin dB	Detector	Comment
1	*	34.8500	46.65	-15.12	31.53	40.00	-8.47	peak	
2		114.8750	40.54	-16.95	23.59	43.50	-19.91	peak	
3		253.1000	36.83	-14.93	21.90	46.00	-24.10	peak	
4		505.3000	31.62	-9.31	22.31	46.00	-23.69	peak	
5		684.7500	29.68	-5.86	23.82	46.00	-22.18	peak	
6		939.3750	29.46	-1.80	27.66	46.00	-18.34	peak	

Test Mode: TX Mode-Model: LR3A-M13

Horizontal

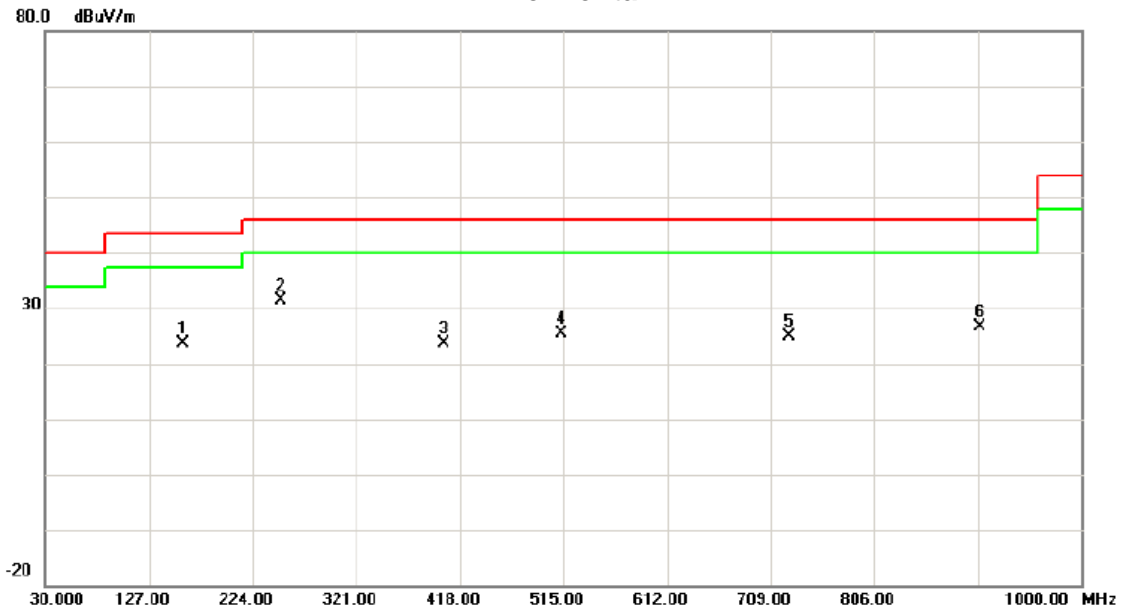

No.	Mk.	Freq. MHz	Reading Level dBuV	Correct Factor dB	Measure- ment dBuV/m	Limit dBuV/m	Margin dB	Detector	Comment
1		158.5250	37.66	-14.04	23.62	43.50	-19.88	peak	
2	*	250.6750	46.49	-15.04	31.45	46.00	-14.55	peak	
3		403.4500	34.72	-11.14	23.58	46.00	-22.42	peak	
4		512.5750	34.38	-9.12	25.26	46.00	-20.74	peak	
5		725.9750	29.95	-5.18	24.77	46.00	-21.23	peak	
6		905.4250	29.44	-2.72	26.72	46.00	-19.28	peak	

ATTACHMENT D -RADIATED EMISSION (ABOVE 1000MHZ)

Test Mode : TX Mode-Model: LR7A-M13

Vertical

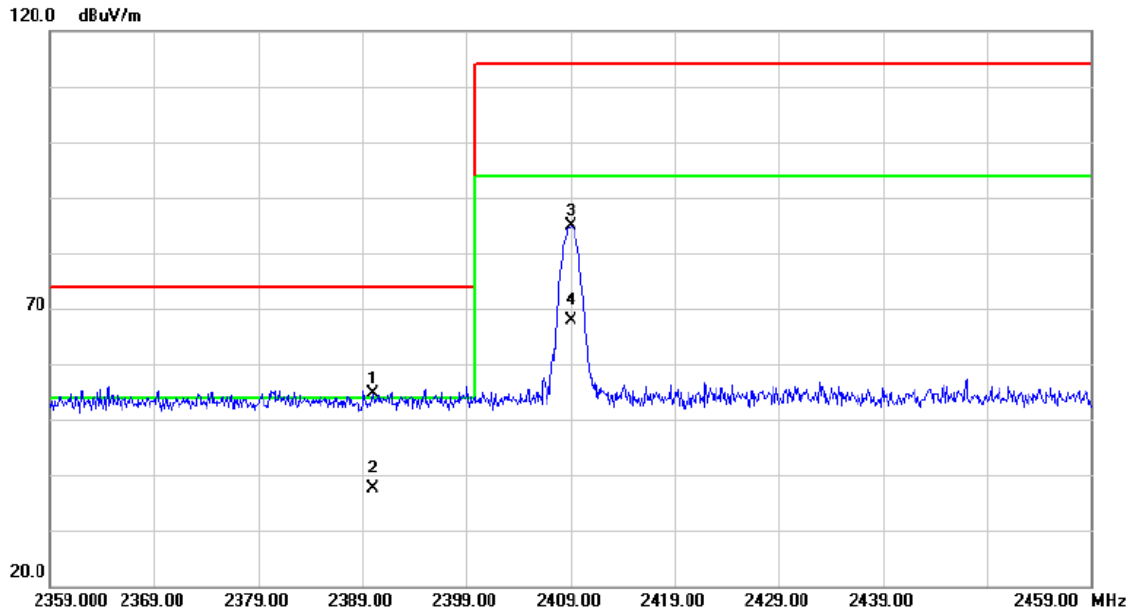

No.	Mk.	Freq. MHz	Reading Level dBuV	Correct Factor dB	Measure- ment dBuV/m	Limit dBuV/m	Margin dB	Detector	Comment
1		2390.000	24.10	30.56	54.66	74.00	-19.34	peak	
2	*	2390.000	7.08	30.56	37.64	54.00	-16.36	AVG	
3		2409.000	54.18	30.62	84.80	114.00	-29.20	peak	NO LIMIT
4		2409.000	37.16	30.62	67.78	94.00	-26.22	AVG	NO LIMIT

Test Mode : TX Mode-Model: LR7A-M13

Vertical

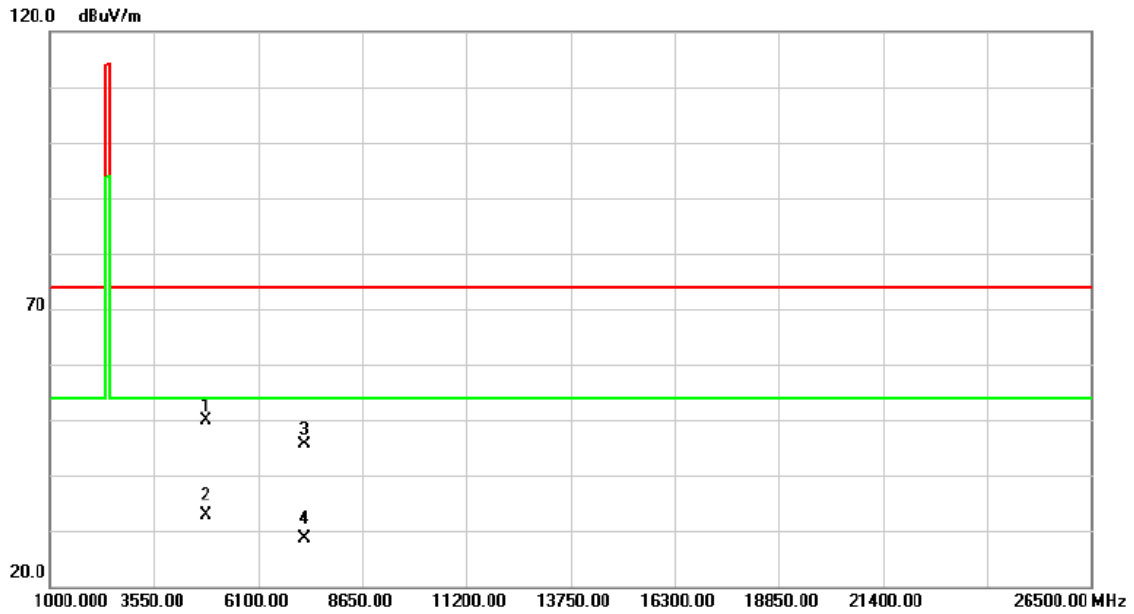

No.	Mk.	Freq. MHz	Reading Level dBuV	Correct Factor dB	Measure- ment dBuV/m	Limit dBuV/m	Margin dB	Detector	Comment
1		4818.050	46.68	3.29	49.97	74.00	-24.03	peak	
2	*	4818.050	29.66	3.29	32.95	54.00	-21.05	AVG	
3		7226.650	37.10	8.44	45.54	74.00	-28.46	peak	
4		7226.650	20.08	8.44	28.52	54.00	-25.48	AVG	

Test Mode : TX Mode-Model: LR7A-M13

Horizontal

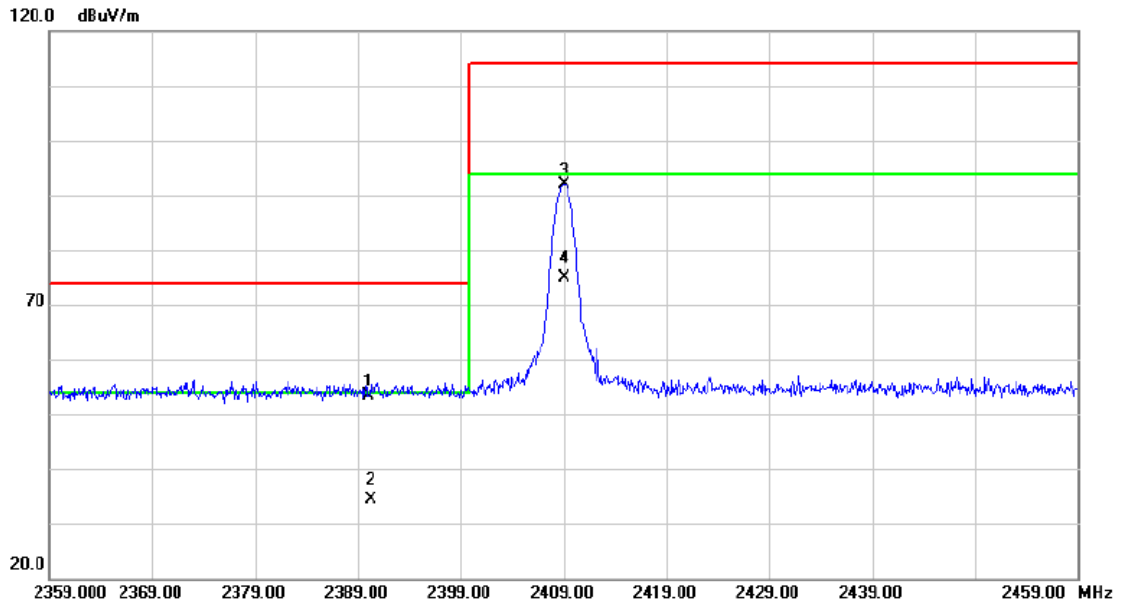

No.	Mk.	Freq. MHz	Reading Level dBuV	Correct Factor dB	Measure- ment dBuV/m	Limit dBuV/m	Margin dB	Detector	Comment
1		2390.000	22.89	30.56	53.45	74.00	-20.55	peak	
2		2390.000	3.87	30.56	34.43	54.00	-19.57	AVG	
3		2409.000	61.27	30.62	91.89	114.00	-22.11	peak	NO LIMIT
4	*	2409.000	44.25	30.62	74.87	94.00	-19.13	AVG	NO LIMIT

Test Mode : TX Mode-Model: LR7A-M13

Horizontal

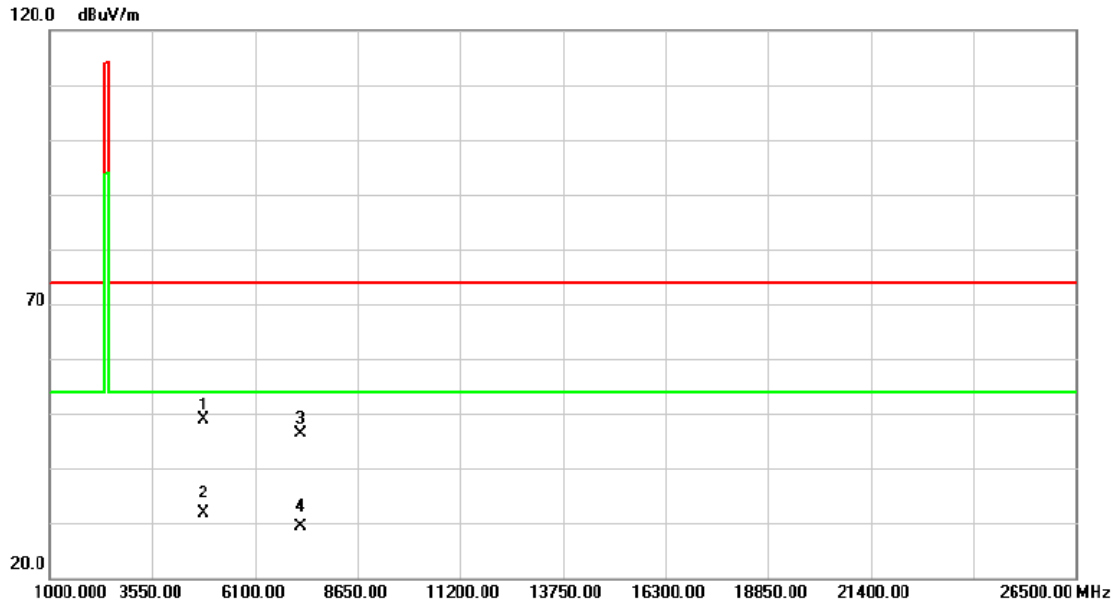

No.	Mk.	Freq. MHz	Reading Level dBuV	Correct Factor dB	Measure- ment dBuV/m	Limit dBuV/m	Margin dB	Detector	Comment
1		4818.200	45.67	3.29	48.96	74.00	-25.04	peak	
2	*	4818.200	28.65	3.29	31.94	54.00	-22.06	AVG	
3		7227.150	38.00	8.44	46.44	74.00	-27.56	peak	
4		7227.150	20.98	8.44	29.42	54.00	-24.58	AVG	

Test Mode : TX Mode-Model: LR3A-M13

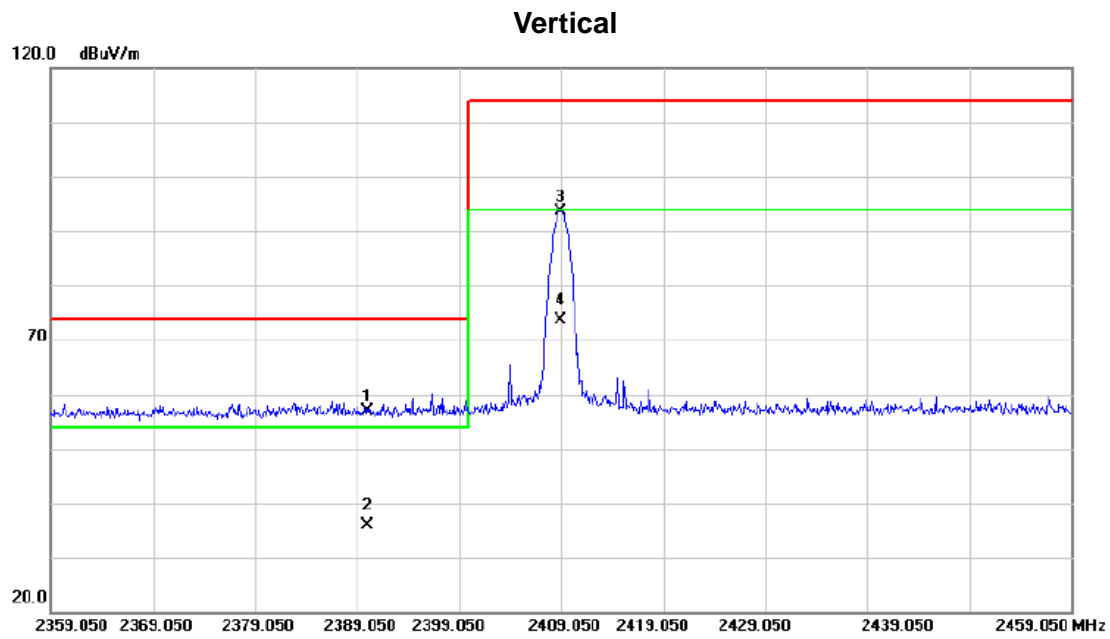

No.	Mk.	Freq. MHz	Reading Level dBuV	Correct Factor dB	Measure- ment dBuV/m	Limit dBuV/m	Margin dB	Detector	Comment
1	*	2390.000	24.95	31.96	56.91	74.00	-17.09	peak	
2		2390.000	4.01	31.96	35.97	54.00	-18.03	AVG	
3		2408.950	61.56	32.02	93.58	114.0	-20.42	peak	NO LIMIT
4		2408.950	41.57	32.02	73.59	94.00	-20.41	AVG	NO LIMIT

Test Mode : TX Mode-Model: LR3A-M13

Vertical

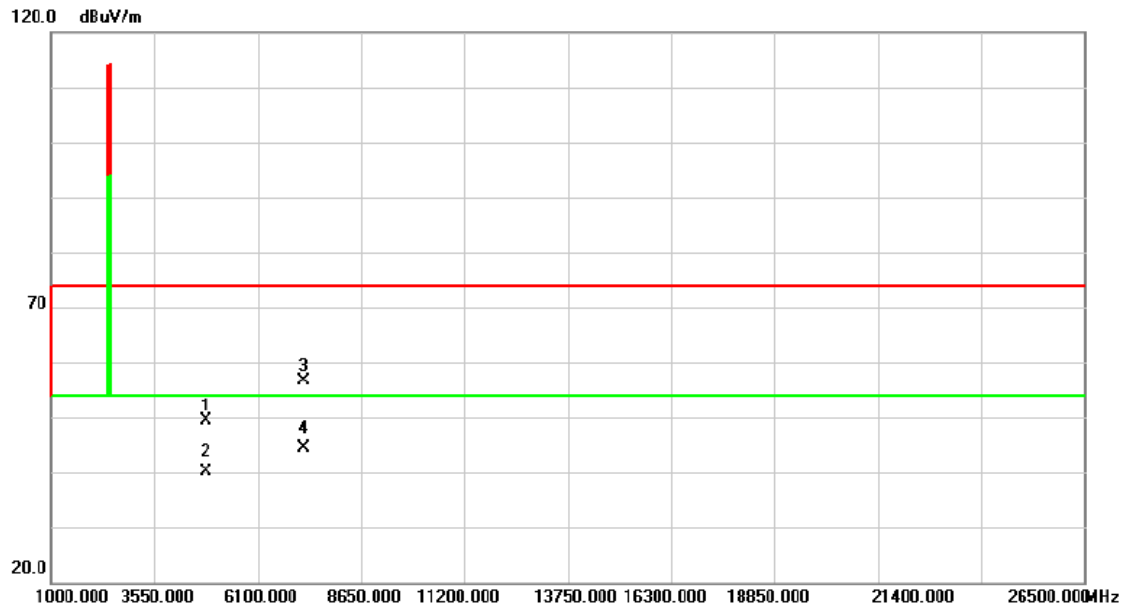

No.	Mk.	Freq. MHz	Reading Level dBuV	Correct Factor dB	Measure- ment dBuV/m	Limit dBuV/m	Margin dB	Detector	Comment
1		4817.520	43.68	5.79	49.47	74.00	-24.53	peak	
2		4817.520	34.26	5.79	40.05	54.00	-13.95	AVG	
3		7224.720	42.74	13.85	56.59	74.00	-17.41	peak	
4	*	7224.720	30.41	13.85	44.26	54.00	-9.74	AVG	

Test Mode : TX Mode-Model: LR3A-M13

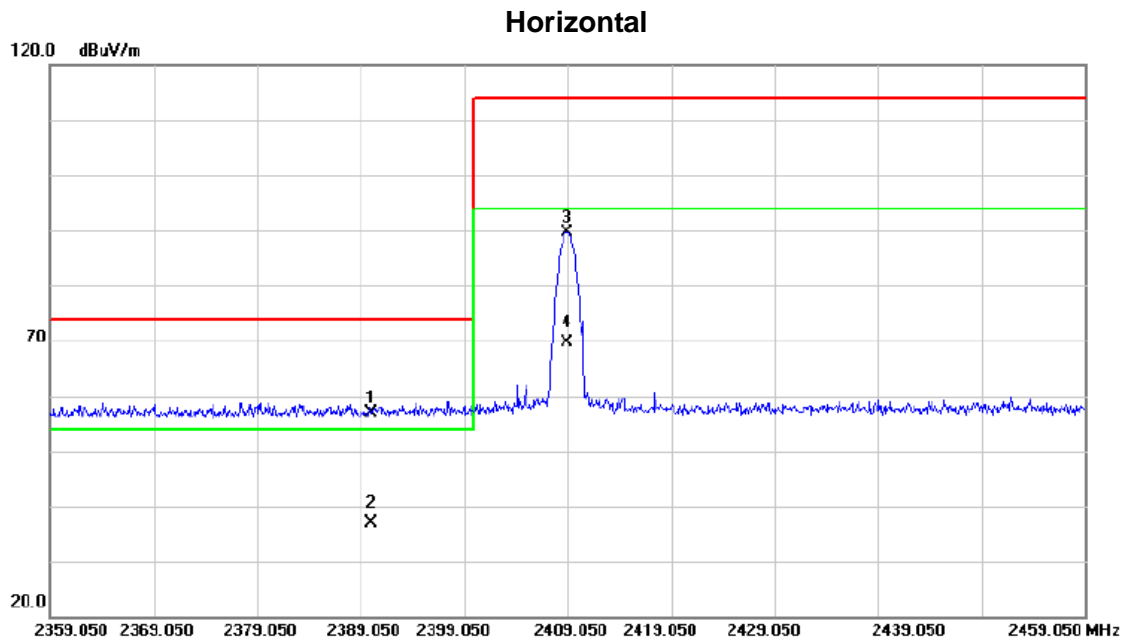

No.	Mk.	Freq. MHz	Reading Level dBuV	Correct Factor dB	Measure- ment dBuV/m	Limit dBuV/m	Margin dB	Detector	Comment
1		2390.000	24.96	31.96	56.92	74.00	-17.08	peak	
2	*	2390.000	4.97	31.96	36.93	54.00	-17.07	AVG	
3		2408.950	57.64	32.02	89.66	114.0	-24.34	peak	NO LIMIT
4		2408.950	37.65	32.02	69.67	94.00	-24.33	AVG	NO LIMIT

Test Mode : TX Mode-Model: LR3A-M13

Horizontal

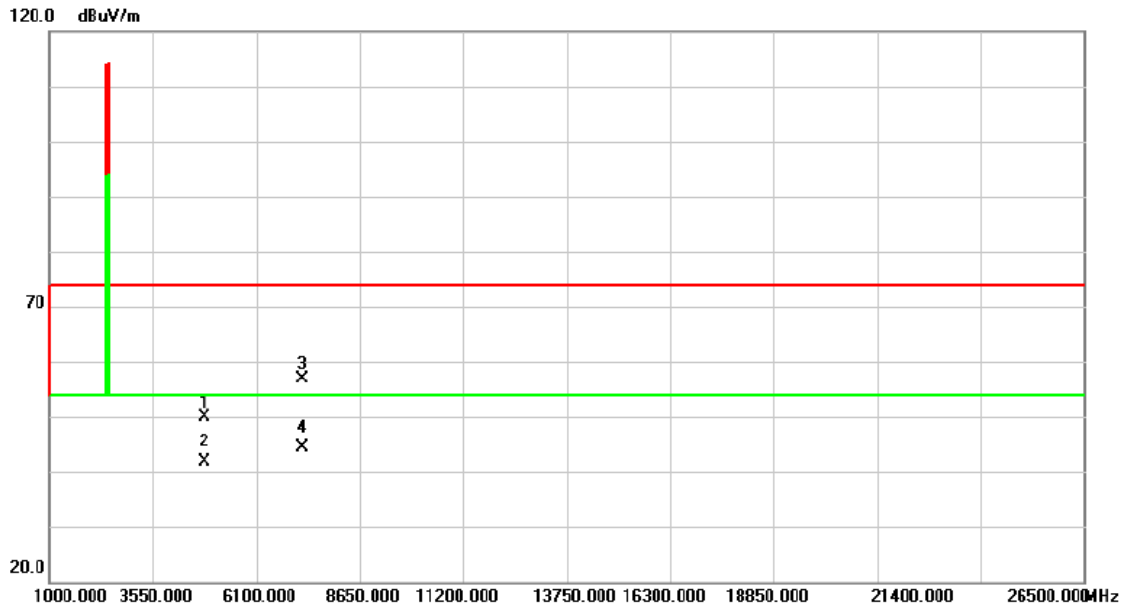

No. Mk.	Freq. MHz	Reading Level dBuV	Correct Factor dB	Measurement dBuV/m	Limit dBuV/m	Margin dB	Detector	Comment
1	4818.100	44.08	5.79	49.87	74.00	-24.13	peak	
2	4818.100	35.97	5.79	41.76	54.00	-12.24	AVG	
3	7226.880	43.02	13.86	56.88	74.00	-17.12	peak	
4 *	7226.880	30.64	13.86	44.50	54.00	-9.50	AVG	

ATTACHMENT E - BANDWIDTH

Test Mode:	TX Mode- Model: LR7A-M13
------------	--------------------------

Frequency (MHz)	20dB Bandwidth (MHz)	99% Occupied BW (MHz)
2409	0.49	0.93

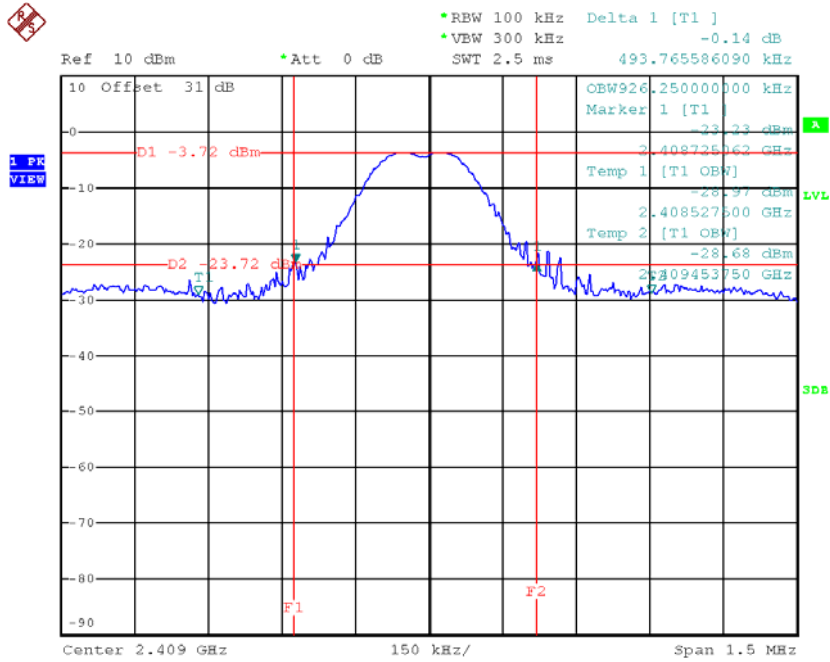

Date: 20.AUG.2015 18:11:06

Test Mode: TX Mode- Model: LR3A-M13

Frequency (MHz)	20dB Bandwidth (MHz)	99% Occupied BW (MHz)
2409	0.49	0.54

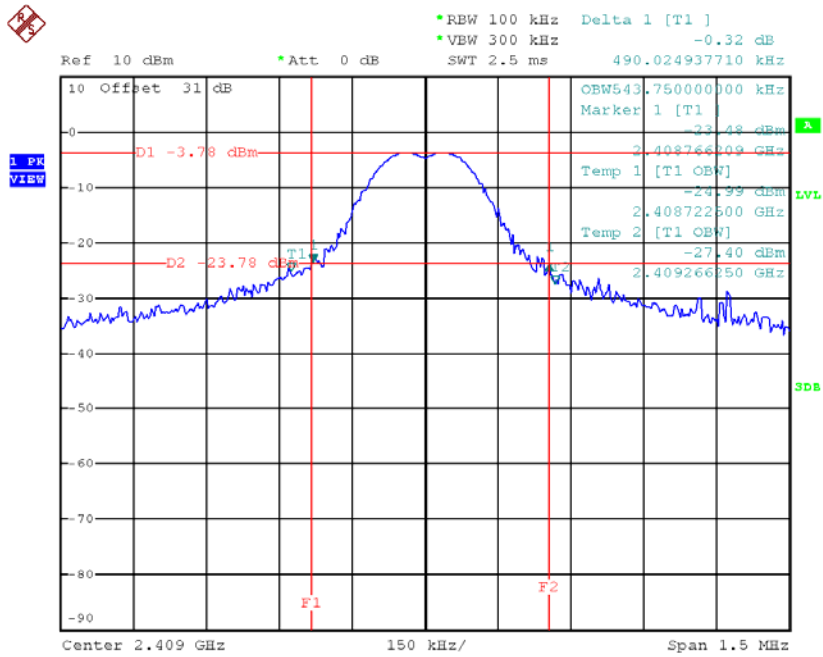

Date: 20.AUG.2015 20:07:17