

1 Key Neutral Touch Switch (LR3A-M13) Specification

Specification

- Per channel lighting load (350 Watts)
- Lighting overload protect function
- Lighting switch over temperature protect function
- Auto lighting turn off delay function
- Relay protecting circuit
- AC Full range input : 100~240V AC
- 2.4G RF Remote Control

Front View



LR3A-M13



L6N5A-AW

Touch Switch wiring circuit

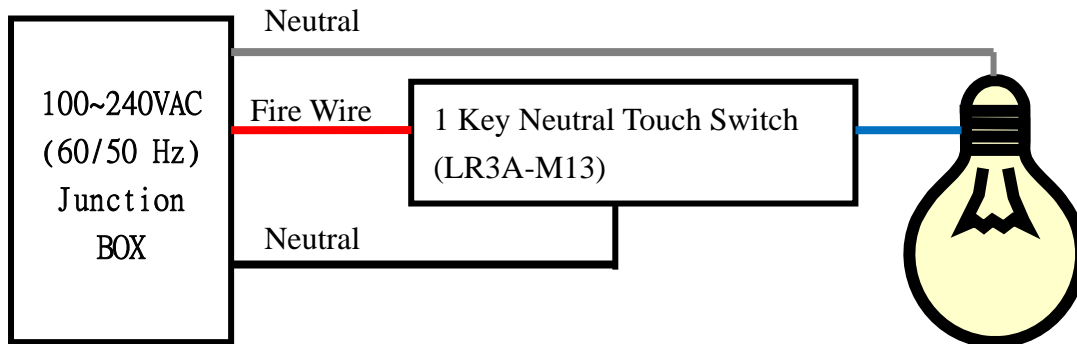

Over Load

When the touch switch circuit loop, if installed too many lamps, switch will detect the loop current after turn on the lighting, touch switch normal operating current is 3.5A (amps), once the instantaneous current detection circuit exceeds 6.5A (amps), touch switch will automatically power-off , Buzzer (beeper) will beep sound after 10 stops, At the same time light control switch delay the function stop of 30 seconds, touch function is inactive during this period, when the touch function recovery, and lighting control switch function stop, please kindly check the lighting circuit.

Over Temperature

If the lamp lighting control switch in the ON state when the touch switch detects the ambient temperature above $75\text{ }^{\circ}\text{C} \pm 5\%$, the internal over-temperature protection circuit will immediately power off, wait until the temperature drops below to $60\text{ }^{\circ}\text{C} \pm 5\%$, The protection circuit automatically back to function state, when the pre to this case, please kindly check the lighting loop circuit.

Delay Time

Lighting control switch can set the delay time of 5 minutes turn off the lights.

Electrical Characteristics

AC input	100~240V AC (60/50 Hz)
RF remote distance	12 Meter
Touch switch load	350W
Time delay turn off	1 Minutes
Over load	>350W +30%
Over temperature	>75°C ±5% turn off ; 60°C ±5% Back to function

FCC Statement

This equipment has been tested and found to comply with the limits for a Class B digital device, pursuant to part 15 of the FCC Rules. These limits are designed to provide reasonable protection against harmful interference in a residential installation. This equipment generates, uses and can radiate radio frequency energy and, if not installed and used in accordance with the instructions, may cause harmful interference to radio communications. However, there is no guarantee that interference will not occur in a particular installation. If this equipment does cause harmful interference to radio or television reception, which can be determined by turning the equipment off and on, the user is encouraged to try to correct the interference by one or more of the following measures:

- Reorient or relocate the receiving antenna.
- Increase the separation between the equipment and receiver.
- Connect the equipment into an outlet on a circuit different from that to which the receiver is connected.
- Consult the dealer or an experienced radio/TV technician for help.

FCC Radiation Exposure Statement

This device complies with FCC radiation exposure limits set forth for an uncontrolled environment and it also complies with Part 15 of the FCC RF Rules. This equipment must be installed and operated in accordance with provided instructions and the antenna(s) used for this transmitter must be installed to provide a separation distance of at least 20 cm from all persons and must not be co-located or operating in conjunction with any other antenna or transmitter. End-users and installers must be provided with antenna installation instructions and consider removing the no-collocation statement.

This device complies with Part 15 of the FCC Rules. Operation is subject to the following two conditions:

- (1) this device may not cause harmful interference, and
- (2) this device must accept any interference received, including interference that may cause undesired operation.

Caution!

1. Any changes or modifications not expressly approved by the party responsible for compliance could void the user's authority to operate the equipment.
2. Indoor use only