

Prüfbericht-Nr.: <i>Test Report No.:</i>	50045765 001	Auftrags-Nr.: <i>Order No.:</i>	114050332	Seite 1 von 50 <i>Page 1 of 50</i>
Kunden-Referenz-Nr.: <i>Client Reference No.:</i>	N/A	Auftragsdatum: <i>Order date:</i>	27-Apr-2016	
Auftraggeber: <i>Client:</i>	Supra Foto-Elektronik-Vertriebs-GmbH, Denisstrae 28A D-67663 Kaiserslautern Germany			
Prüfgegenstand: <i>Test item:</i>	WLAN Repeater			
Bezeichnung / Typ-Nr.: <i>Identification / Type No.:</i>	Maginon WLR-755 AC			
Auftrags-Inhalt: <i>Order content:</i>	FCC Part 15E Test report			
Prüfgrundlage: <i>Test specification:</i>	FCC 47CFR Part 15: Subpart E Section 15.407			
Wareneingangsdatum: <i>Date of receipt:</i>	11-May-2016			
Prüfmuster-Nr.: <i>Test sample No.:</i>	A000348257-009 A000348257-010			
Prüfzeitraum: <i>Testing period:</i>	27-May-2016 - 31-May-2016			
Ort der Prüfung: <i>Place of testing:</i>	EMC/RF Laboratory Taipei			
Prüflaboratorium: <i>Testing laboratory:</i>	TUV Rheinland Taiwan Ltd.			
Prüfergebnis*: <i>Test result*:</i>	Pass			
geprüft von / tested by:		kontrolliert von / reviewed by:		
				
2016-06-07	Ryan W. T. Chen / Project Manager	2016-06-07	Rene Charton/Senior Project Manager	
Datum <i>Date</i>	Name / Stellung <i>Name / Position</i>	Unterschrift <i>Signature</i>	Datum <i>Date</i>	Name / Stellung <i>Name / Position</i>
				Unterschrift <i>Signature</i>
Sonstiges / Other: Aldi Order No.: IB-2016-1454				
Zustand des Prüfgegenstandes bei Anlieferung: <i>Condition of the test item at delivery:</i>		Prüfmuster vollständig und unbeschädigt <i>Test item complete and undamaged</i>		
* Legende: 1 = sehr gut 2 = gut 3 = befriedigend 4 = ausreichend 5 = mangelhaft P(ass) = entspricht o.g. Prüfgrundlage(n) F(ail) = entspricht nicht o.g. Prüfgrundlage(n) N/A = nicht anwendbar N/T = nicht getestet		Legend: 1 = very good 2 = good 3 = satisfactory 4 = sufficient 5 = poor P(ass) = passed a.m. test specification(s) F(ail) = failed a.m. test specification(s) N/A = not applicable N/T = not tested		
Dieser Prüfbericht bezieht sich nur auf das o.g. Prüfmuster und darf ohne Genehmigung der Prüfstelle nicht auszugsweise vervielfältigt werden. Dieser Bericht berechtigt nicht zur Verwendung eines Prüfzeichens. <i>This test report only relates to the a. m. test sample. Without permission of the test center this test report is not permitted to be duplicated in extracts. This test report does not entitle to carry any test mark.</i>				
v04				

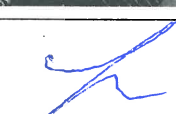
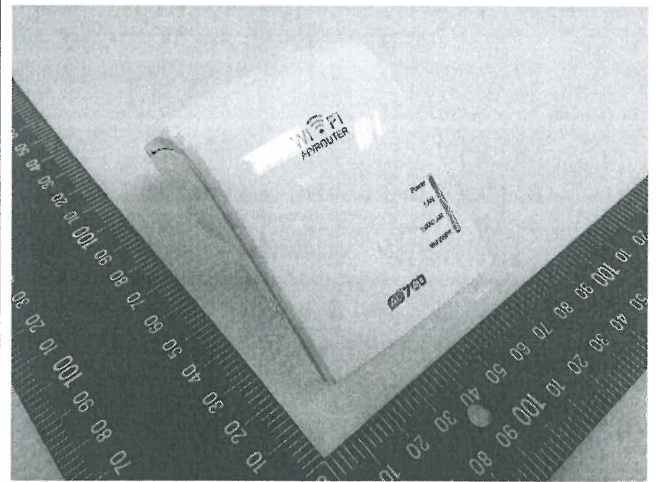

TEST SUMMARY

5.1.1 ANTENNA REQUIREMENT

RESULT: Passed

5.1.2 26 dB BANDWIDTH AND 99% BANDWIDTH (5150-5250MHz)

RESULT: Passed

5.1.3 6 dB AND 99% BANDWIDTH (5725-5850MHz)

RESULT: Passed

5.1.4 TRANSMIT OUTPUT POWER

RESULT: Passed

5.1.5 POWER SPECTRAL DENSITY

RESULT: Passed

5.1.6 SPURIOUS EMISSION

RESULT: Passed

5.2.1 MAINS CONDUCTED EMISSIONS

RESULT: Passed

Contents

1.	GENERAL REMARKS	5
1.1	COMPLEMENTARY MATERIALS.....	5
2.	TEST SITES	6
2.1	TEST FACILITIES	6
2.2	LIST OF TEST AND MEASUREMENT INSTRUMENTS.....	7
2.3	TRACEABILITY	8
2.4	CALIBRATION	8
2.5	MEASUREMENT UNCERTAINTY	8
3.	GENERAL PRODUCT INFORMATION.....	9
3.1	PRODUCT FUNCTION AND INTENDED USE	9
3.2	RATINGS AND SYSTEM DETAILS.....	9
3.3	INDEPENDENT OPERATION MODES.....	11
3.4	NOISE GENERATING AND NOISE SUPPRESSING PARTS	12
3.5	SUBMITTED DOCUMENTS.....	12
4.	TEST SET-UP AND OPERATION MODES.....	13
4.1	PRINCIPLE OF CONFIGURATION SELECTION	13
4.2	TEST OPERATION AND TEST SOFTWARE.....	13
4.3	SPECIAL ACCESSORIES AND AUXILIARY EQUIPMENT	13
4.4	COUNTERMEASURES TO ACHIEVE EMC COMPLIANCE.....	14
4.5	TEST SETUP DIAGRAM	14
5.	ANTENNA PORT TEST RESULTS.....	16
5.1	TRANSMITTER REQUIREMENT & TEST SUITES	16
5.1.1	Antenna Requirement	16
5.1.2	26 dB Bandwidth and 99% Bandwidth (5150-5250MHz)	17
5.1.3	6 dB and 99% Bandwidth (5725-5850MHz).....	24
5.1.4	Transmit Output Power.....	31
5.1.5	Power Spectral Density	34
5.1.6	Spurious Emission.....	45
5.2	MAINS EMISSIONS.....	46
5.2.1	Mains Conducted Emissions	46
	PHOTOGRAPHS OF THE TEST SET-UP	47

Prüfbericht - Nr.: 50045765 001
Test Report No.

Seite 4 von 51
Page 4 of 51

6.	LIST OF TABLES	51
7.	LIST OF PHOTOGRAPHS.....	51

1. General Remarks

1.1 Complementary Materials

All attachments are integral parts of this test report. This applies especially to the following appendix:

Appendix P: Photo Documentation internal view
(File Name: 50045765APPENDIX P)

Appendix D: Test Result of Radiated Emissions
(File Name: 50045765APPENDIX D)

Test Specifications

The following standards were applied:

Table 1: Applied Standard and Test Levels

Radio
FCC CFR47 Part 15 Subpart E
ANSI C63.10:2013
FCC KDB-789033
FCC KDB-662911 D01
FCC KDB-644545

2. Test Sites

2.1 Test Facilities

TUV Rheinland Taiwan Ltd.

11F. No.758, Sec. 4, Bade Rd., Songshan Dist.
Taipei City 105
Taiwan (R.O.C.)

FCC Registration No.: 365730
IC Canada Registration No.: 9465A-1
TAF Accredited NCC Test Lab. No.:0759

2.2 List of Test and Measurement Instruments

Table 2: List of Test and Measurement Equipment

Kind of Equipment	Manu-facturer	Type	S/N	Last Calibration	Next Calibration
Test Software	Farad	EZ_EMCC	Ver. TUV3A1	N/A	N/A
EMI Test Receiver	R&S	ESR7	101062	10-Sep-15	10-Sep-16
Spectrum Analyzer	R&S	FSV 40	100921	21-Dec-15	21-Dec-16
Spectrum Analyzer	Agilent	N9010A	MY53470241	25-Apr-16	24-Apr-17
Preamplifier (30MHz -1GHz)	HP	8447F	2805A03335	31-Aug-15	31-Aug-16
Preamplifier (18 GHz -40 GHz)	COM-POWER	PAM-840	461257	19-Nov-15	19-Nov-16
Pre-Amplifier (1GHz~18GHz)	EM Electronics	EM01G18G	060558	19-Nov-15	19-Nov-16
Bilog Antenna	TESEQ	CBL6111D	29802	4-Jul-14	4-Jul-16
Horn Antenna	ETS-Lindgren	3117	138160	12-Jan-15	12-Jan-17
Horn Antenna (18GHz~40GHz)	COM-POWER	AH840	101031	22-Oct-15	21-Oct-17
Loop Antenna	Schwarzbeck	FMZB 1513	1513-076	21-Oct-14	20-Oct-16
EMI Test Receiver	R&S	ESCI7	100797	28-Dec-15	27-Dec-16
Spectrum Analyzer	R&S	FSL3	101943	7-Sep-15	7-Sep-16
Temp. & Humid. Chamber	Giant Force	GCT-099-40-S	MAF0103-007	13-Jul-15	12-Jul-16
LISN (1 phase)	R&S	ENV216	101243	1-Jun-15	30-Jun-16
LISN	R&S	ENV216	101262	16-Jun-15	15-Jun-16

2.3 Traceability

All measurement equipment calibrations are traceable to NML(Taiwan)/NIST(USA) or where calibration is performed outside Taiwan, to equivalent nationally recognized standards organizations.

2.4 Calibration

Equipment requiring calibration is calibrated periodically in a suitably accredited Calibration Lab. Additionally all equipment is verified for proper performance on a regular schedule using in house standards or comparisons.

2.5 Measurement Uncertainty

The estimated combined standard uncertainty for radiated emissions and conducted emissions measurements are:.

Table 3: Emission Measurement Uncertainty

Parameter	Uncertainty
Radio Frequency	$\pm 1 \times 10^{-7}$
RF power, conducted	± 1.5 dB
Adjacent channel power	± 3 dB
Radiated emission of transmitter, valid up to 40 GHz	± 6 dB
Radiated emission of receiver, valid up to 40 GHz	± 6 dB
Temperature	± 2 °C
Humidity	± 10 %

3. General Product Information

3.1 Product Function and Intended Use

The EUT is a WLAN Repeater. It contains a 802.11a/b/g/n/ac compatible module enabling the user to communicate data through a Wireless interface.
For details refer to the User Guide, Data Sheet and Circuit Diagram.

3.2 Ratings and System Details

Table 4: Technical Specification of EUT

Technical Specification	Value
Kind of Equipment	WLAN Repeater
Brand Name	Maginon
FCC ID	Z5CWLR755
Type Designation	Maginon WLR-755 AC
Operating Frequency	5150 MHz ~ 5250 MHz, 5725MHz ~ 5850MHz
Operation Voltage	230V
Modulation	OFDM with BPSK, QPSK, QAM
Antenna gain	peak gain: 3 dBi
Antenna Type	PIFA Antenna

Table 5: Test Channel Frequency information

Band	CH	Frequency
		(MHz)
802.11a Band I	36	5180
802.11a Band I	44	5220
802.11a Band I	46	5230
802.11a Band IV	149	5745
802.11a Band IV	157	5785
802.11a Band IV	165	5825
802.11n (HT20) Band I	36	5180
802.11n (HT20) Band I	44	5220
802.11n (HT20) Band I	48	5240
802.11n (HT20) Band IV	149	5745
802.11n (HT20) Band IV	157	5785
802.11n (HT20) Band IV	165	5825
802.11n (HT40) Band I	38	5190
802.11n (HT40) Band I	46	5230
802.11n (HT40) Band IV	151	5755
802.11n (HT40) Band IV	159	5795
802.11n (HT80) Band I	42	5210
802.11n (HT80) Band IV	155	5775

3.3 Independent Operation Modes

The basic operation modes are:

- A. Transmitting
 - 1. Low channel
 - 2. Middle channel
 - 3. High channel
- B. Receiving
- C. Standby
- D. Off

3.4 Noise Generating and Noise Suppressing Parts

Refer to the Circuit Diagram.

3.5 Submitted Documents

- Circuit Diagram
- Instruction Manual
- Rating Label
- Technical Description

4. Test Set-up and Operation Modes

4.1 Principle of Configuration Selection

The equipment under test (EUT) was configured to measure its maximum power level. The test modes were adapted accordingly in reference to the instructions for use.

4.2 Test Operation and Test Software

Setup for testing: Test samples are provided with a SPI interface which makes it possible to control them through a test software installed on a notebook computer.

This software was running on the laptop computer connected to the EUT. It was used to enable the operation modes listed in section 3.3 as appropriate. The samples were used as follows:

Conducted: A0COND22757-001
Radiation: ArAD022608-001

Full test was applied on all test modes, but only worst case was shown.

4.3 Special Accessories and Auxiliary Equipment

The product has been tested together with the following additional accessories:

Description	Manufacturer	Model No.	Serial No.
Notebook(EMC-06)	Lenovo	TP00048A	PB-0F8B2

4.4 Countermeasures to achieve EMC Compliance

The test sample which has been tested contained the noise suppression parts as described in the Constructional Data Form or the Technical Construction File. No additional measures were employed to achieve compliance.

4.5 Test Setup Diagram

Diagram of Measurement Configuration for Radiation Test

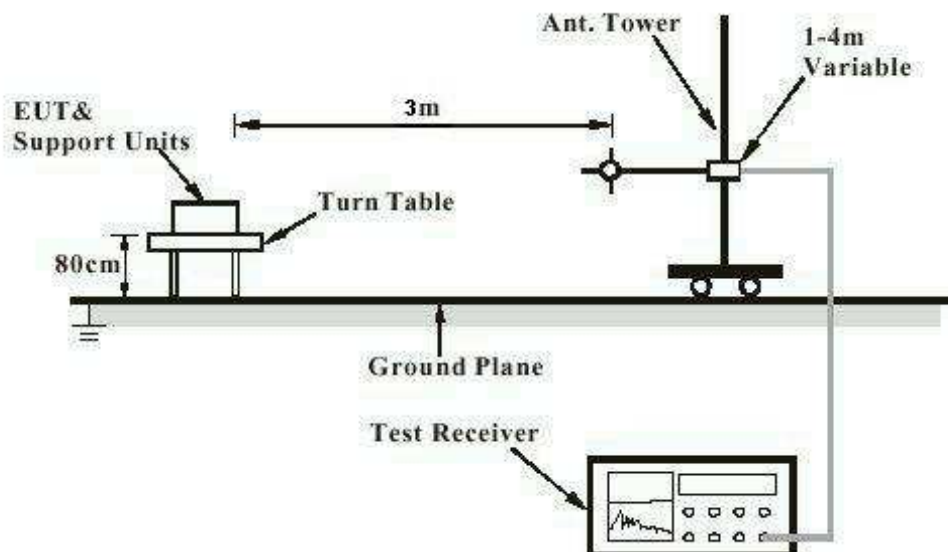

Diagram of Measurement Equipment Configuration for Mains Conduction Measurement

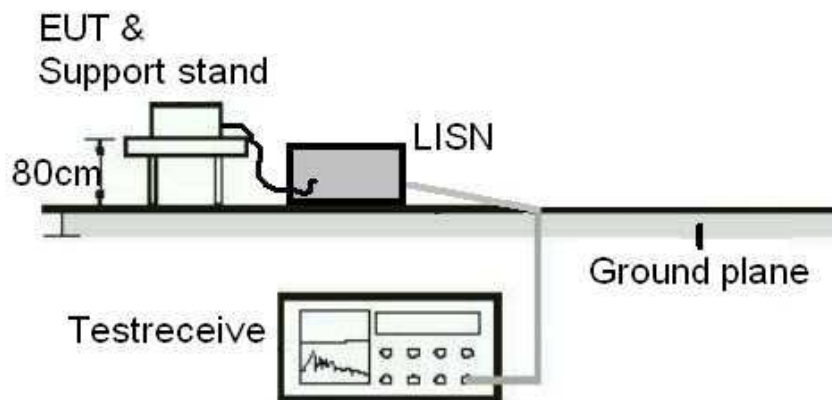
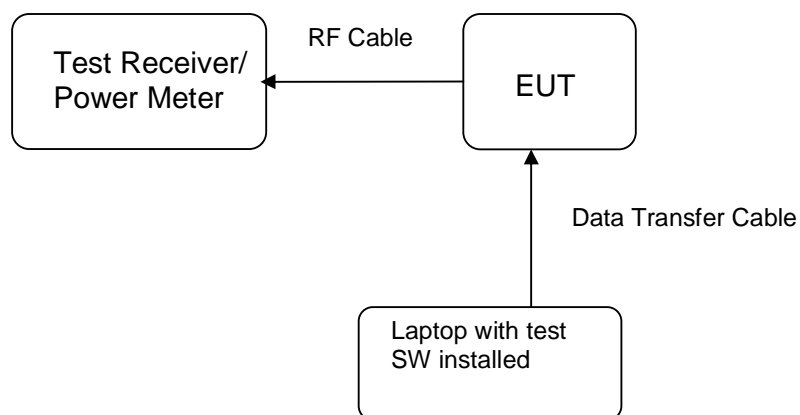

Diagram of Measurement Equipment Configuration for Conducted Transmitter Measurement



5. Antenna Port Test Results

5.1 Transmitter Requirement & Test Suites

5.1.1 Antenna Requirement

RESULT: **Passed**

Test standard : LP0002(2011): 3.10.1, (3)
FCC Part 15.407(a), Part 15.203 and RSS-
Gen 7.1.4

Limit : the use of antennas with directional gains that do not
exceed 6 dBi

According to the manufacturer declaration, the EUT has an antenna with a directional gain of 3 dBi. The antenna is PIFA Antenna with no possibility of replacement with a non-approved antenna by the end-user. Therefore, the EUT is considered to comply with this provision.

Refer to EUT photo for details.

5.1.2 26 dB Bandwidth and 99% Bandwidth (5150-5250MHz)

RESULT:
Passed

Test standard : FCC Part 15.407(a), RSS-247 6.2.1
 Kind of test site : Shielded room

Test setup

Test Channel : Low/ Middle/ High
 Operation Mode : A

Ambient temperature : 22-26 °C
 Relative humidity : 50-65 %
 Atmospheric pressure : 100-103 kPa

Table 6: Test result of 26dB/99% Bandwidth (11a)

Channel	Channel Frequency (MHz)	26dB Bandwidth (MHz)	99% Bandwidth (MHz)
Low Channel	5180	21.45	16.554
Mid Channel	5220	21.56	16.576
High Channel	5230	30.77	16.654

Table 7: Test result of 26dB/99% Bandwidth (HT20)

Channel	Channel Frequency (MHz)	26dB Bandwidth (MHz)	99% Bandwidth (MHz)
Low Channel	5180	20.8	17.584
Mid Channel	5220	22.24	17.605
High Channel	5230	25.57	17.667

Table 8: Test result of 26dB/99% Bandwidth (HT40)

Channel	Channel Frequency (MHz)	26dB Bandwidth (MHz)	99% Bandwidth (MHz)
Low Channel	5190	44.56	36.373
High Channel	5220	47.8	36.367

Table 9: Test result of 26dB/99% Bandwidth (HT80)

Channel	Channel Frequency (MHz)	26dB Bandwidth (MHz)	99% Bandwidth (MHz)
Low Channel	5210	99.37	75.895

Test Plot of 26dB Bandwidth (11a)

Low Channel

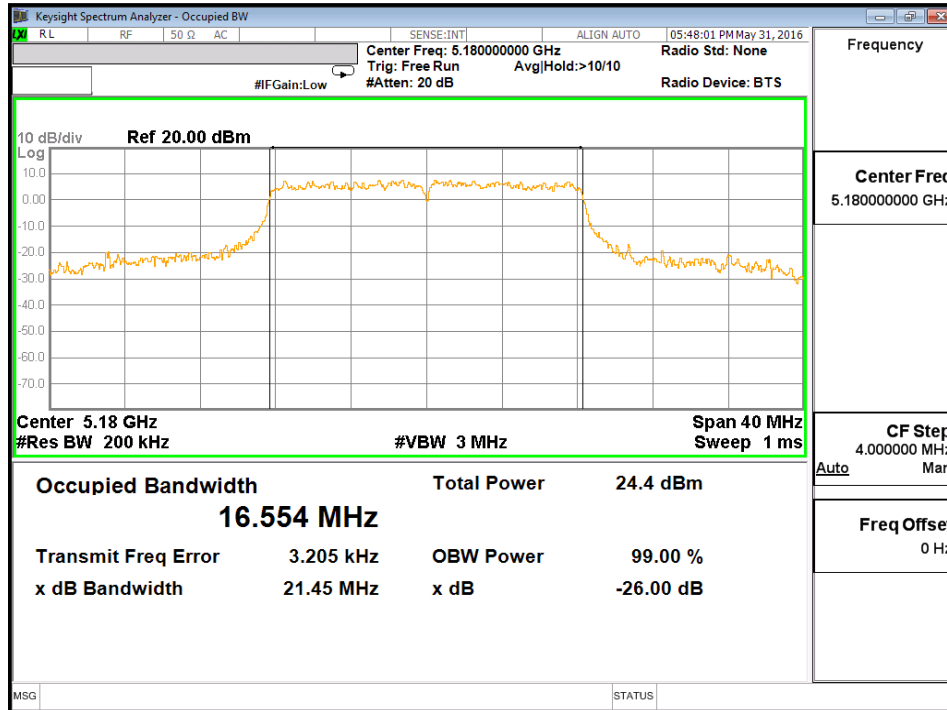

Mid Channel

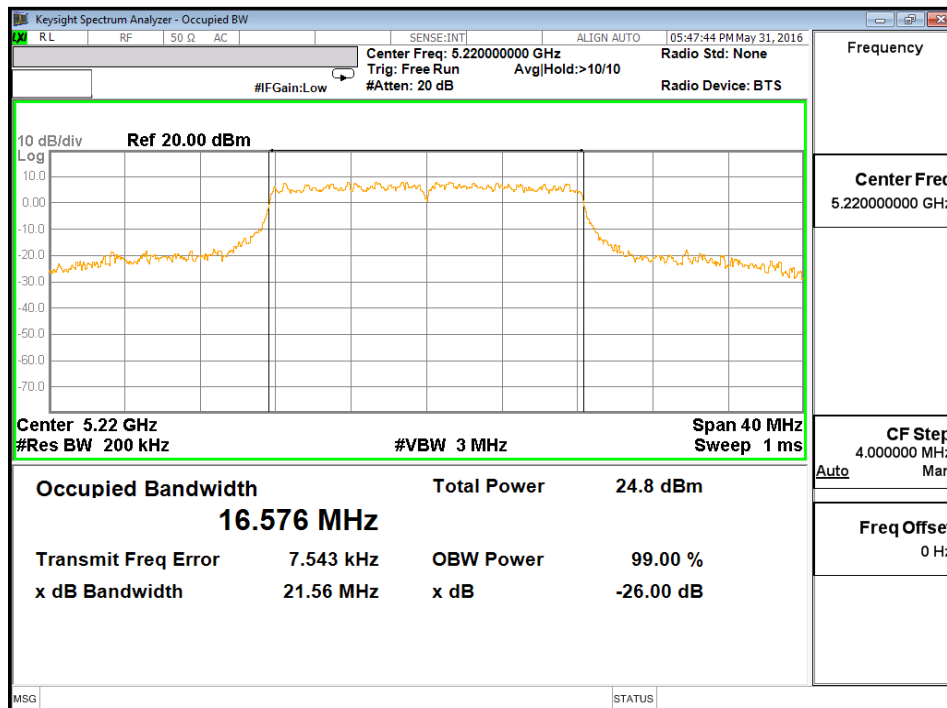

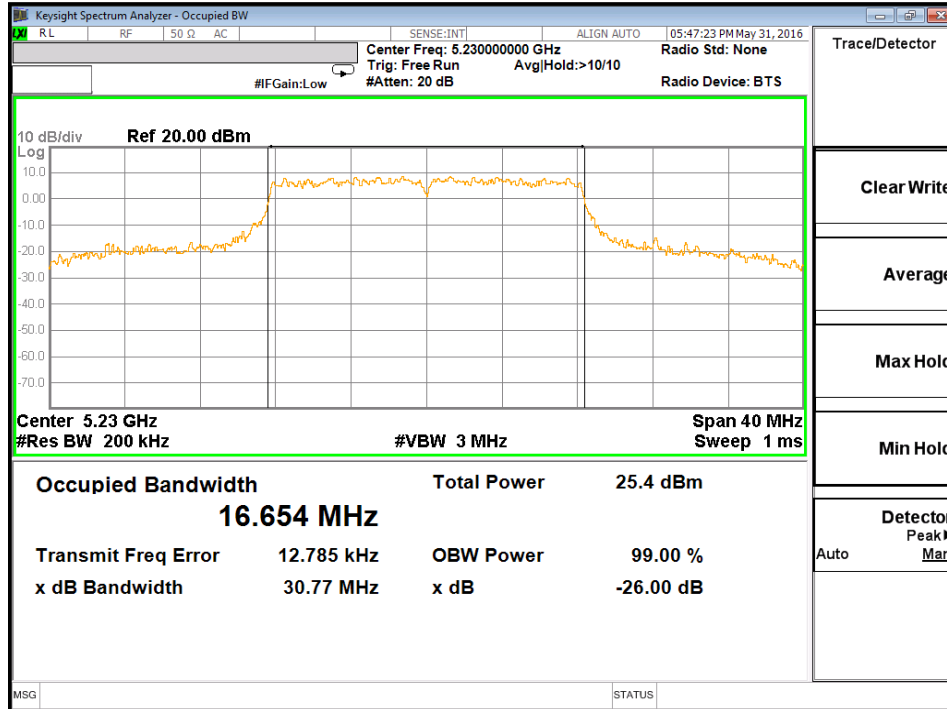
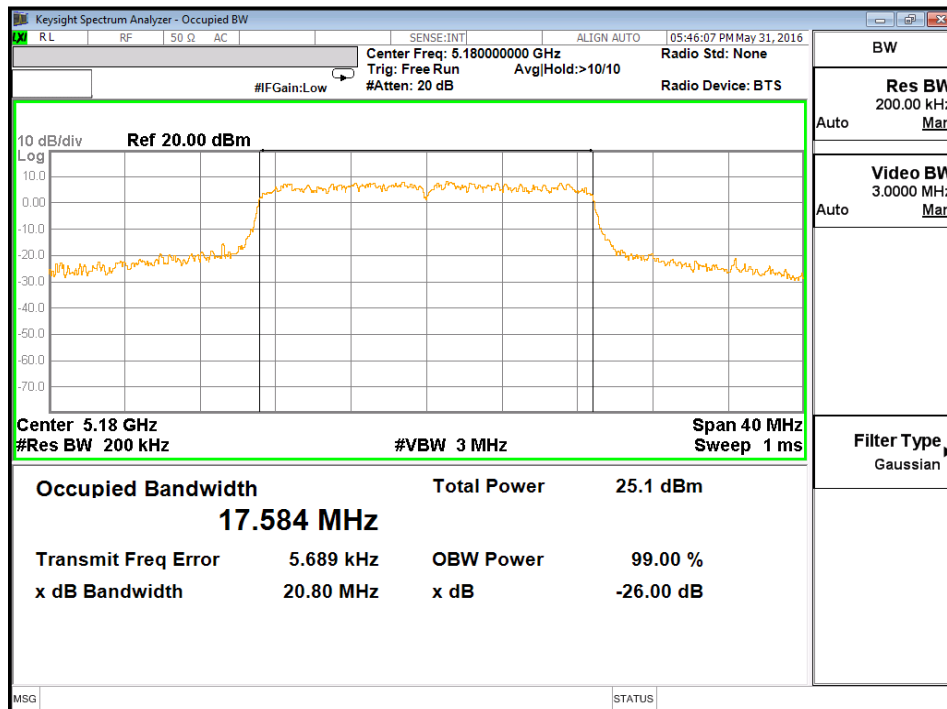
High Channel

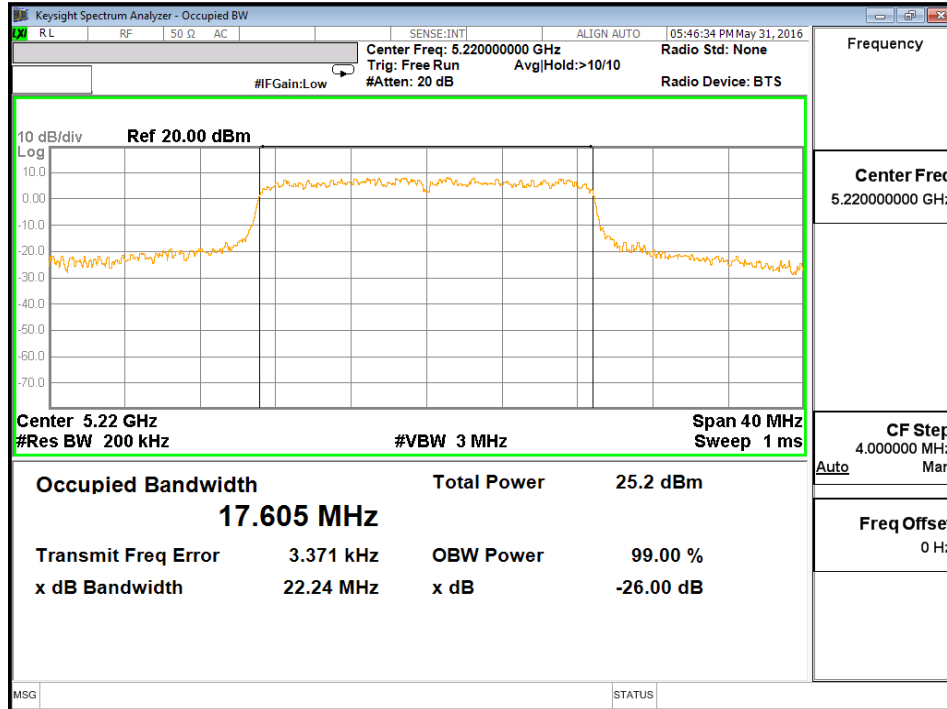
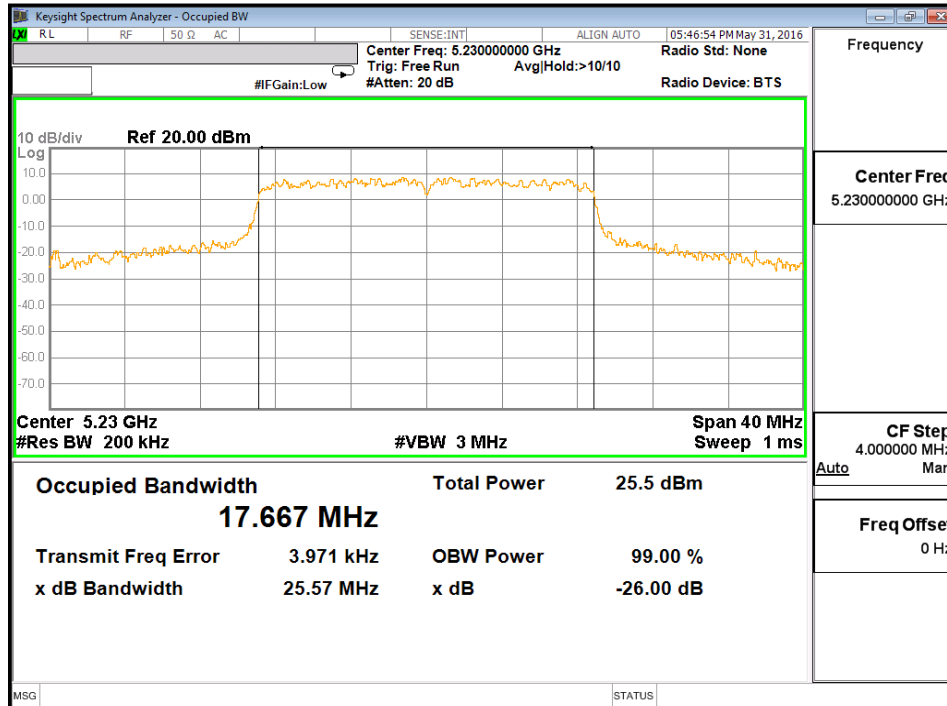
Test Plot of 26dB Bandwidth (HT20)
Low Channel

Mid Channel

High Channel

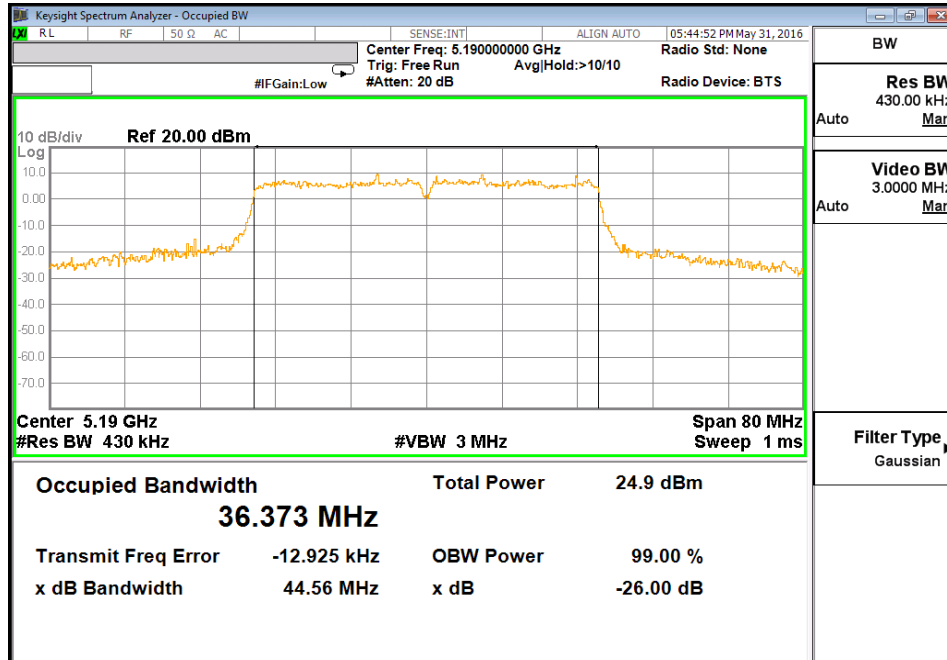
Test Plot of 26dB Bandwidth(HT40)

Low Channel

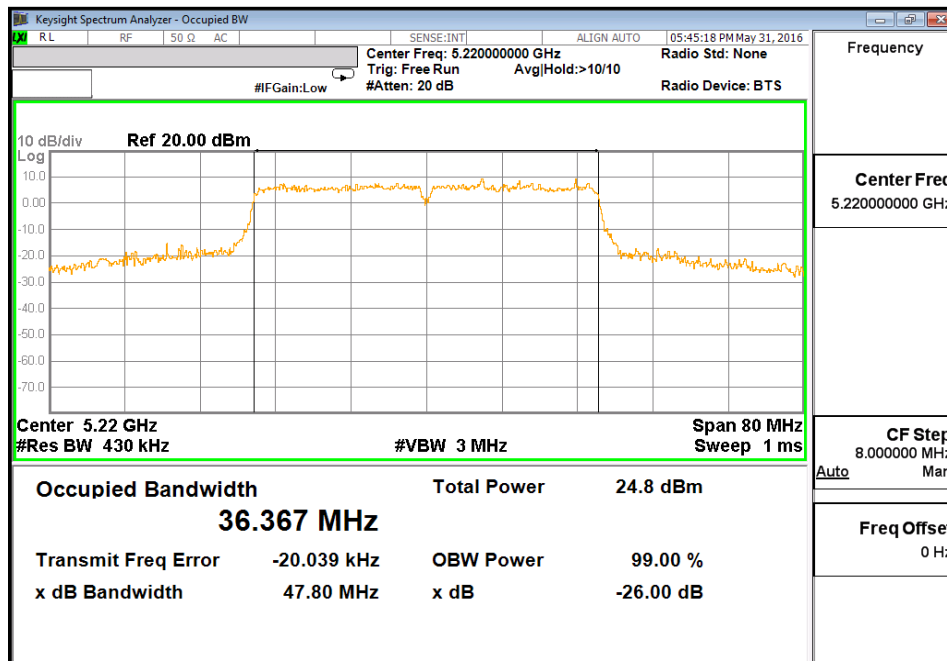

High Channel

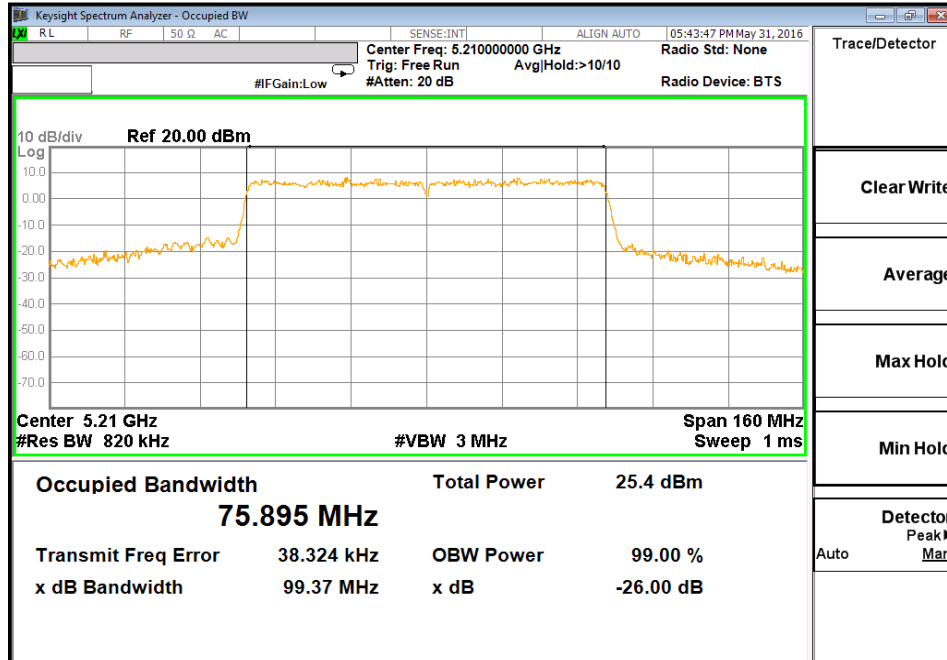

Test Plot of 26dB Bandwidth(HT80)
Low Channel

5.1.3 6 dB and 99% Bandwidth (5725-5850MHz)

RESULT:
Passed

Test standard : FCC Part 15.407(a), RSS-247 6.2.4(1)
 Kind of test site : Shielded room

Test setup

Test Channel : Low/ Middle/ High
 Operation Mode : A
 Ambient temperature : 22-26 °C
 Relative humidity : 50-65 %
 Atmospheric pressure : 100-103 kPa

Table 10: Test result of 6dB Bandwidth and 99% Bandwidth (11a)

Channel	Channel Frequency (MHz)	6dB Bandwidth TX1 (MHz)	99% Bandwidth TX1 (MHz)
Low Channel	5745	16.44	16.602
Mid Channel	5785	16.42	16.72
High Channel	5825	16.42	16.522

Table 11: Test result of 6dB Bandwidth and 99% Bandwidth (HT20)

Channel	Channel Frequency (MHz)	6dB Bandwidth TX1 (MHz)	99% Bandwidth TX1 (MHz)
Low Channel	5745	16.93	17.782
Mid Channel	5785	17.16	17.718
High Channel	5825	17.17	17.58

Table 12: Test result of 6dB Bandwidth and 99% Bandwidth (HT40)

Channel	Channel Frequency (MHz)	6dB Bandwidth TX1 (MHz)	99% Bandwidth TX1 (MHz)
Low Channel	5755	36.36	36.249
High Channel	5795	36.35	36.271

Table 13: Test result of 6dB Bandwidth and 99% Bandwidth (HT80)

Channel	Channel Frequency (MHz)	6dB Bandwidth TX1 (MHz)	99% Bandwidth TX1 (MHz)
Low Channel	5775	75.56	76.132

Test Plot of 6dB Bandwidth (11a)

Low Channel

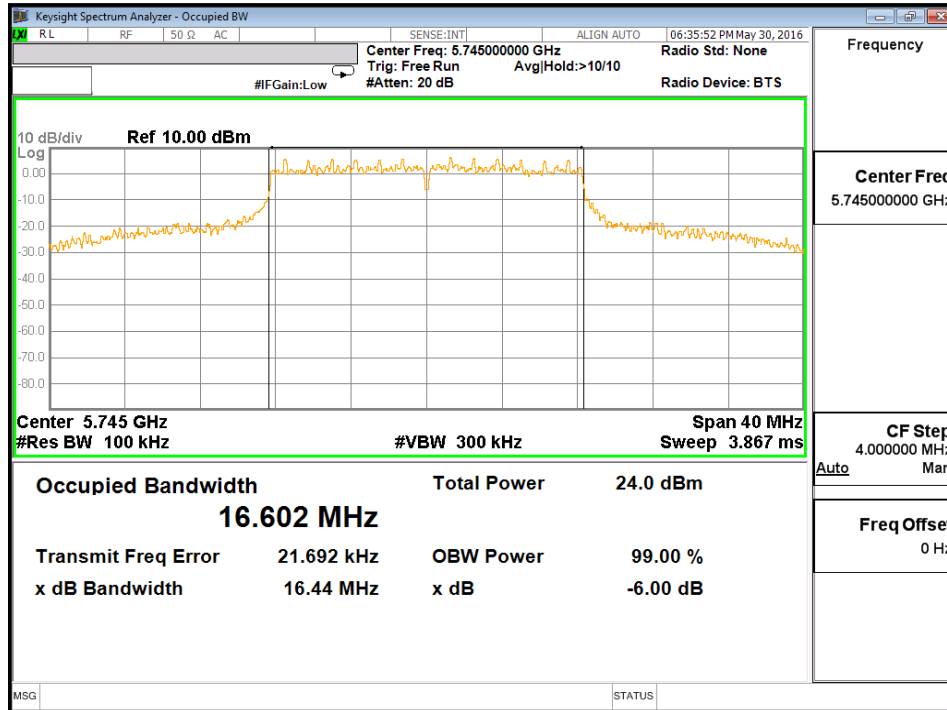

Mid Channel

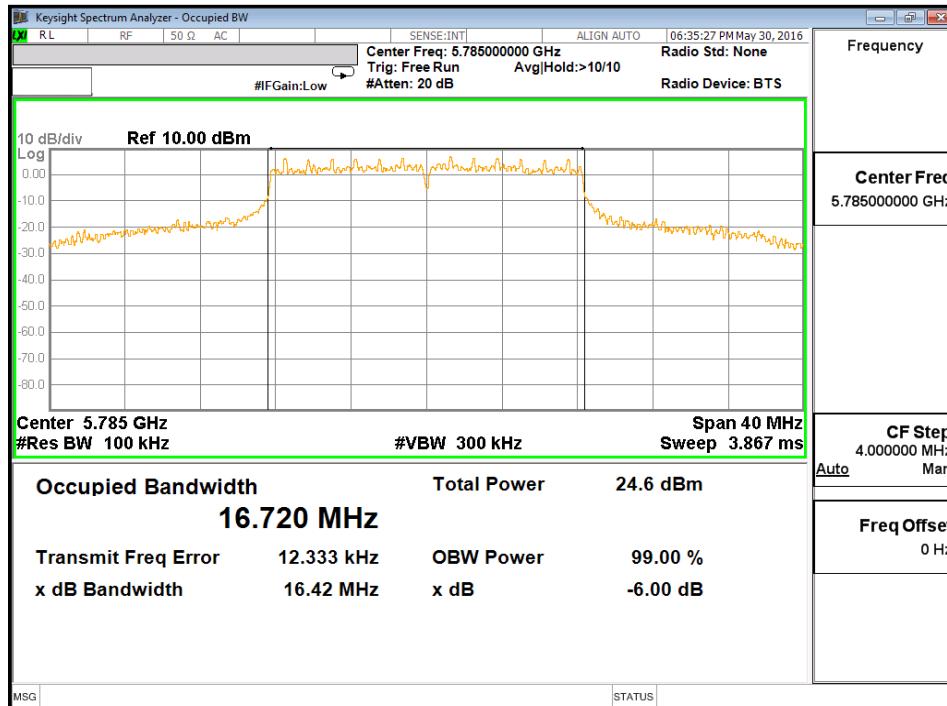

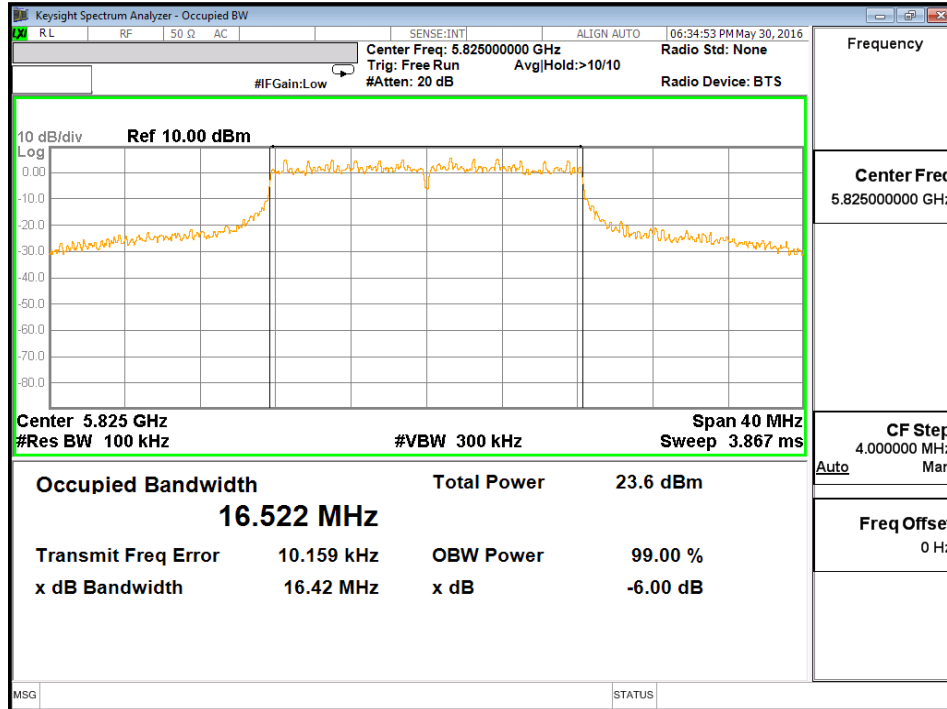
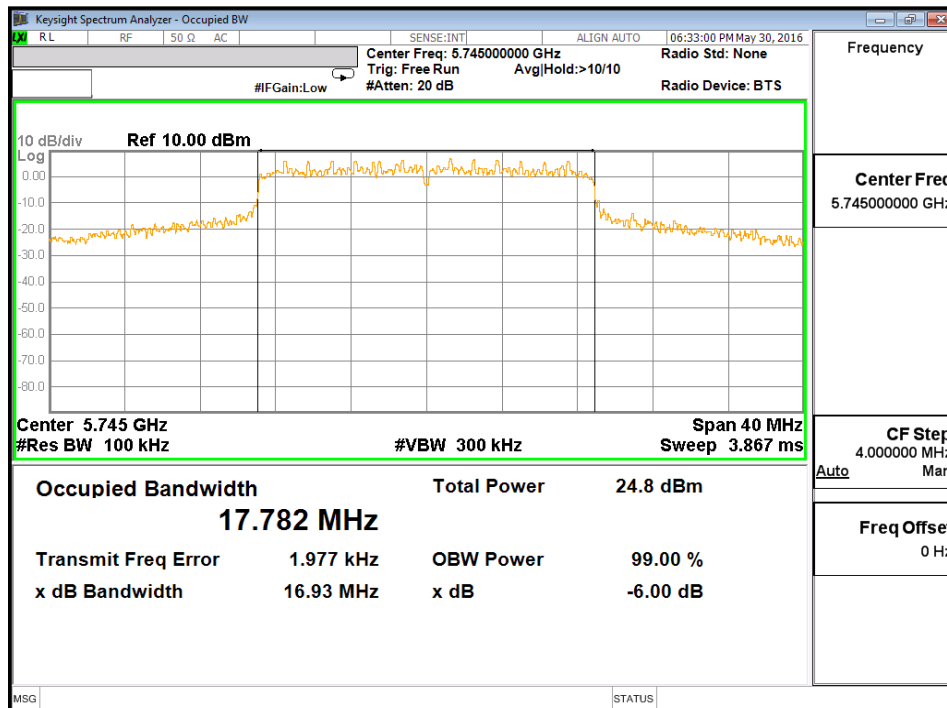
High Channel

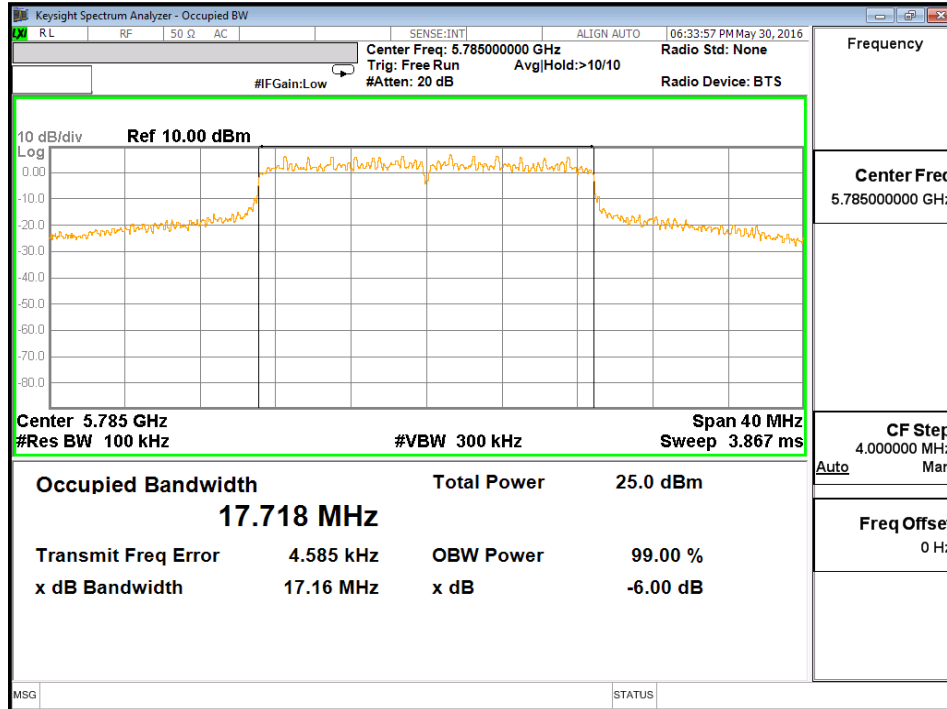
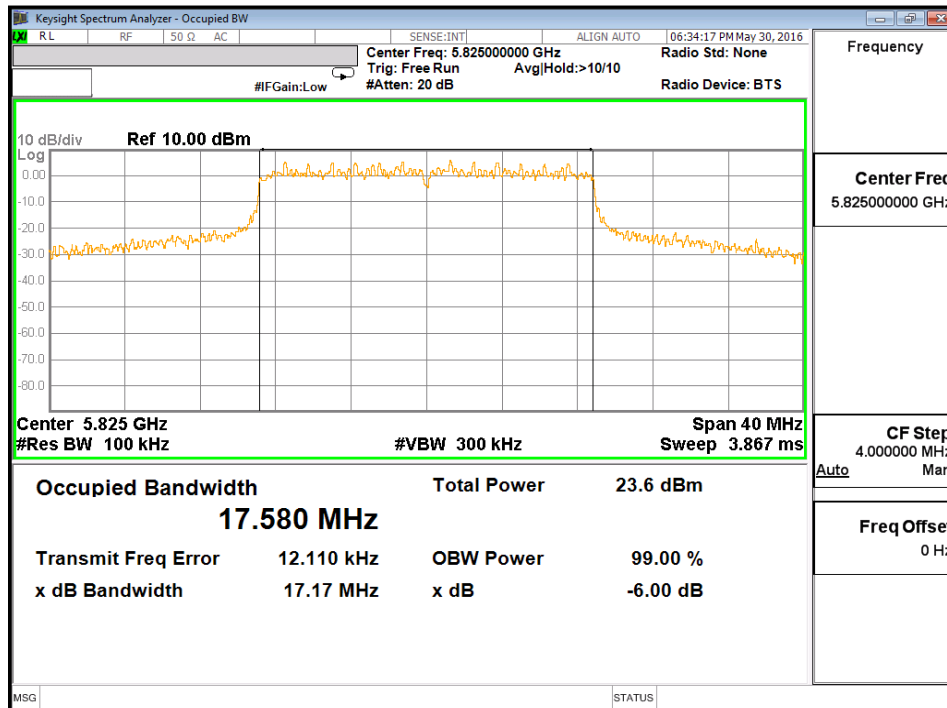
Test Plot of 6dB Bandwidth (HT20)
Low Channel

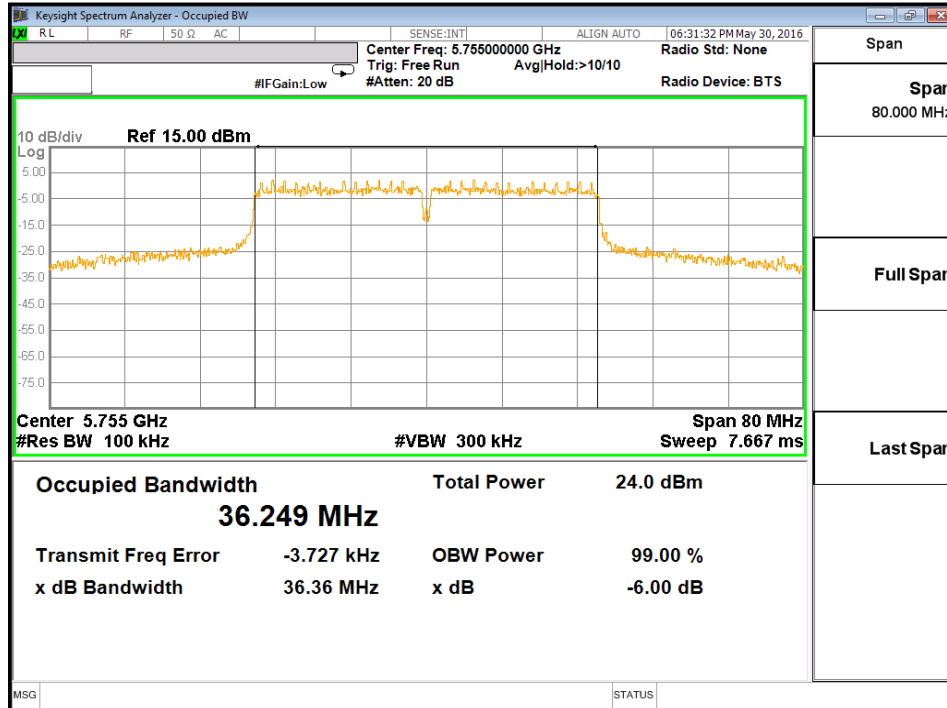
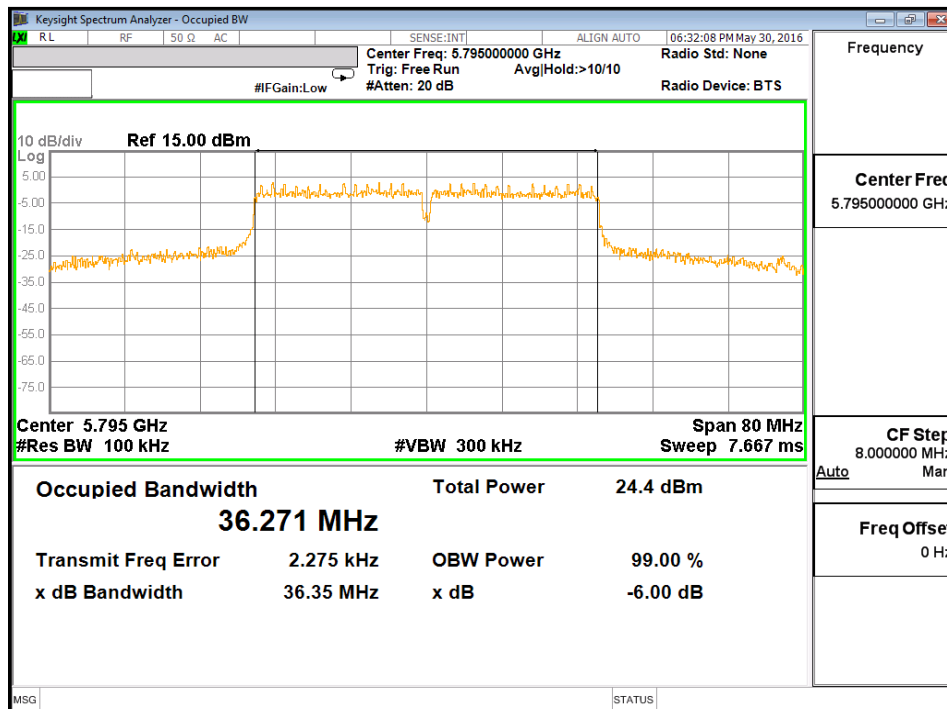
Mid Channel

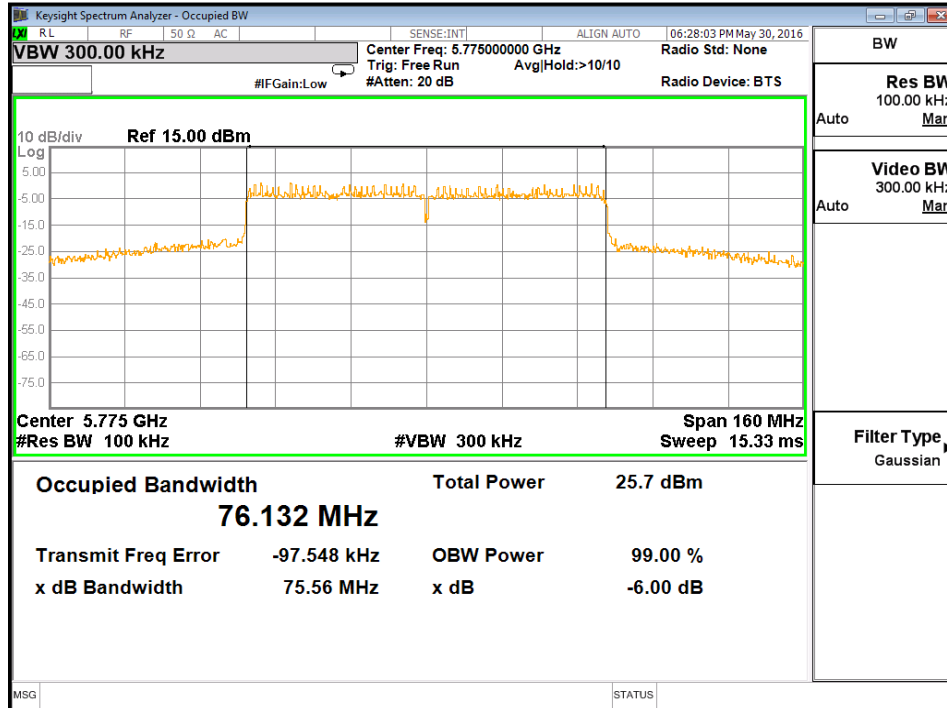
High Channel

Test Plot of 6dB Bandwidth(HT40)
Low Channel

High Channel

Test Plot of 6dB Bandwidth(HT80)
Low Channel

5.1.4 Transmit Output Power

RESULT: **Passed**

Test standard : FCC Part 15.407(a), RSS-247 6.2.1, 6.2.4

Kind of test site : Shielded room

Test setup

Test Channel : Low/ Middle/ High
Operation Mode : A

Ambient temperature : 22-26°C
Relative humidity : 50-65%
Atmospheric pressure : 100-103 kPa

15.407 General technical requirements.

(a) Power limits:

(1) For the band 5.15–5.25 GHz.

For an indoor access point operating in the band 5.155.25 GHz, the maximum conducted output power over the frequency band of operation shall not exceed 1 W provided the maximum antenna gain does not exceed 6 dBi.

In addition, the maximum power spectral density shall not exceed 17 dBm in any 1 megahertz band.

If transmitting antennas of directional gain greater than 6 dBi are used, both the maximum conducted output power and the maximum power spectral density shall be reduced by the amount in dB that the directional gain of the antenna exceeds 6 dBi.

(3) For the band 5.725 - 5.85 GHz,
the maximum conducted output power over the frequency band of operation shall not exceed 1 W.

In addition, the maximum power spectral density shall not exceed 30 dBm in any 500kHz band.

If transmitting antennas of directional gain greater than 6 dBi are used, both the maximum conducted output power and the maximum power spectral density shall be reduced by the amount in dB that the directional gain of the antenna exceeds 6 dBi.

.

Table 14: Test result of Transmit Power (11a)
5150-5250MHz:

Pmax: 349.945167 mW

802.11a		OFDM	BPSK		
Channel	Frequency MHz	Power dBm	Power mW	Limit	Result
Low	5180	25.44	349.9452	1000mW	Pass
Mid	5220	24.82	303.3891	1000mW	Pass
High	5230	25.1	323.5937	1000mW	Pass

5725-5850MHz:

Pmax: 299.9162519 mW

802.11a		OFDM	BPSK		
Channel	Frequency MHz	Power dBm	Power mW	Limit	Result
Low	5745	24.41	276.0578	1000mW	Pass
Mid	5785	24.77	299.9163	1000mW	Pass
High	5825	24.13	258.8213	1000mW	Pass

Table 15: Test result of Transmit Power (HT20)
5150-5250MHz:

 Pmax: 325.0872974 mW
 (HT20)

802.11n		OFDM	BPSK		
Channel	Frequency MHz	Power dBm	Power mW	Limit	Result
Low	5180	25.05	319.8895	1000mW	Pass
Mid	5220	25.12	325.0873	1000mW	Pass
High	5230	24.9	309.0295	1000mW	Pass

5725-5850MHz:

 Pmax: 301.995172 mW
 (HT20)

802.11n		OFDM	BPSK		
Channel	Frequency MHz	Power dBm	Power mW	Limit	Result
Low	5745	24.29	268.5344	1000mW	Pass
Mid	5785	24.8	301.9952	1000mW	Pass
High	5825	24.21	263.6331	1000mW	Pass

Table 16: Test result of Transmit Power (HT40)
5150-5250MHz:

Pmax: 342.7677865 mW

802.11n	OFDM	BPSK	(HT40)		
Channel	Frequency MHz	Power dBm	Power mW	Limit	Result
Low	5190	25.27	336.5116	1000mW	Pass
High	5220	25.35	342.7678	1000mW	Pass

5725-5850MHz:

Pmax: 281.8382931 mW

802.11n	OFDM	BPSK	(HT40)		
Channel	Frequency MHz	Power dBm	Power mW	Limit	Result
Low	5755	24.38	274.1574	1000mW	Pass
High	5795	24.5	281.8383	1000mW	Pass

Table 17: Test result of Transmit Power (HT80)
5150-5250MHz:

Pmax: 311.1716337 mW

802.11n	OFDM	BPSK	(HT80)		
Channel	Frequency MHz	Power dBm	Power mW	Limit	Result
Low	5210	24.93	311.1716	1000mW	Pass

5725-5850MHz:

Pmax: 359.7493352 mW

802.11n	OFDM	BPSK	(HT80)		
Channel	Frequency MHz	Power dBm	Power mW	Limit	Result
Low	5775	25.56	359.7493	1000mW	Pass

5.1.5 Power Spectral Density

RESULT:
Passed

Test standard : FCC Part 15.407(a)(1),(5)
 RSS-247 6.2.1, 6.2.4

Kind of test site : Shielded room

Test setup

Test Channel : Low/ Middle/ High
 Operation Mode : A

Ambient temperature : 22-26°C
 Relative humidity : 50-65%
 Atmospheric pressure : 100-103 kPa

Table 18: Test result of Power Spectral Density (11a_5150-5250MHz)

Channel	Channel Frequency (MHz)	Peak Power Density (dBm)	Limit (dBm/MHz)	Result
Low Channel	5180	15.29	17	Pass
Mid Channel	5220	15.23	17	Pass
High Channel	5230	15.15	17	Pass

Table 19: Test result of Power Spectral Density (HT20)

Channel	Channel Frequency (MHz)	Peak Power Density (dBm)	Limit (dBm/MHz)	Result
Low Channel	5180	15.03	17	Pass
Mid Channel	5220	15.22	17	Pass
High Channel	5230	15.67	17	Pass

Table 20: Test result of Power Spectral Density (HT40)

Channel	Channel Frequency (MHz)	Peak Power Density (dBm)	Limit (dBm/MHz)	Result
Low Channel	5190	10.78	17	Pass
High Channel	5220	11.72	17	Pass

Table 21: Test result of Power Spectral Density (HT80)

Channel	Channel Frequency (MHz)	Peak Power Density (dBm)	Limit (dBm/MHz)	Result
Low Channel	5210	9.14	17	Pass

Table 22: Test result of Power Spectral Density (11a_5725-5850MHz)

Channel	Channel Frequency (MHz)	Peak Power Density (dBm)	Limit (dBm/500kHz)	Result
Low Channel	5745	6.49	30	Pass
Mid Channel	5785	5.91	30	Pass
High Channel	5825	10.575	30	Pass

Table 23: Test result of Power Spectral Density (HT20)

Channel	Channel Frequency (MHz)	Peak Power Density (dBm)	Limit (dBm/500kHz)	Result
Low Channel	5745	6.25	30	Pass
Mid Channel	5785	10	30	Pass
High Channel	5825	10.1	30	Pass

Table 24: Test result of Power Spectral Density (HT40)

Channel	Channel Frequency (MHz)	Peak Power Density (dBm)	Limit (dBm/500kHz)	Result
Low Channel	5755	6.47	30	Pass
High Channel	5795	7.33	30	Pass

Table 25: Test result of Power Spectral Density (HT80)

Channel	Channel Frequency (MHz)	Peak Power Density (dBm)	Limit (dBm/500kHz)	Result
Low Channel	5775	3.57	30	Pass

Test Plot of Power Density (5150-5250MHz)

Low Channel

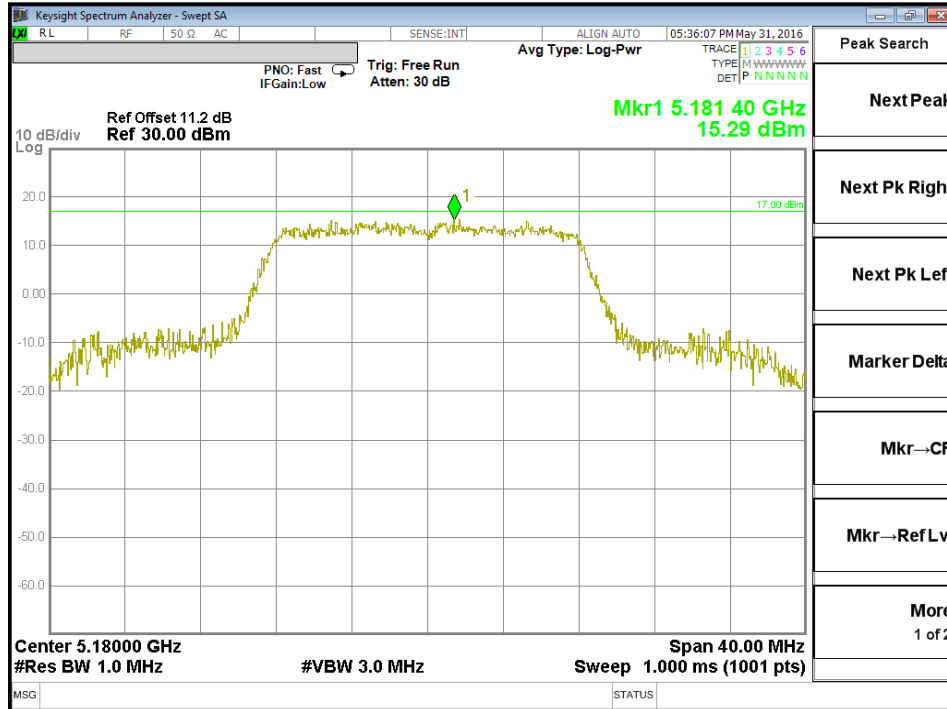

Middle Channel

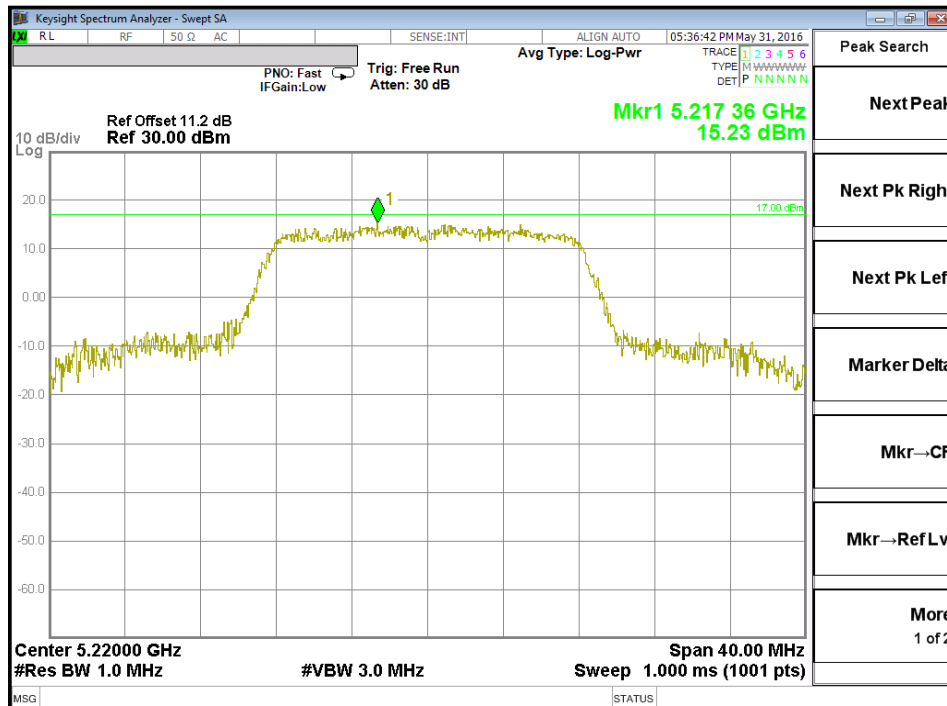

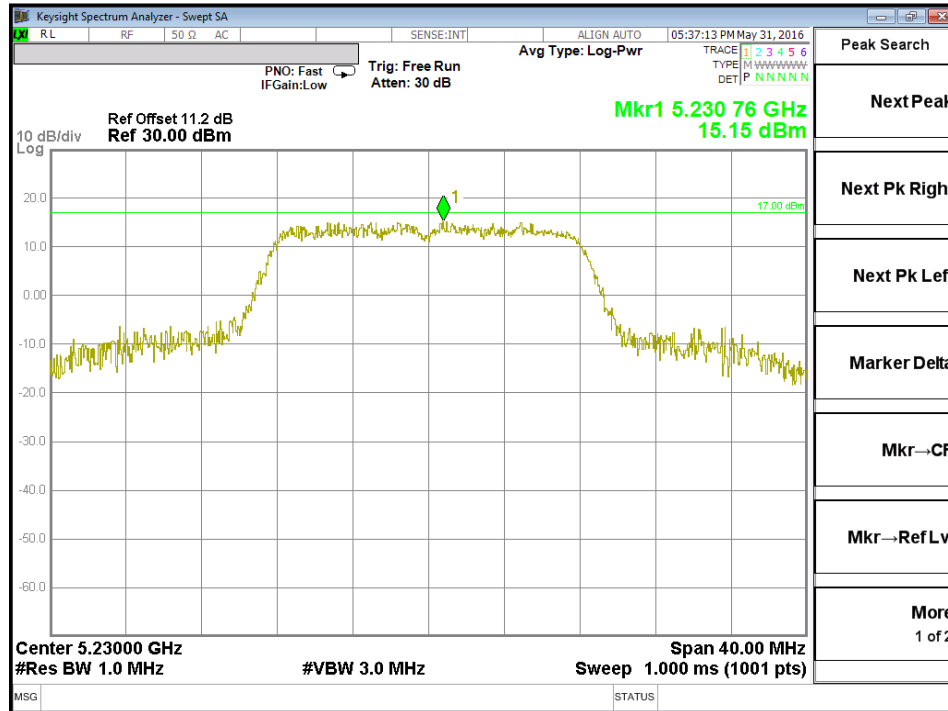
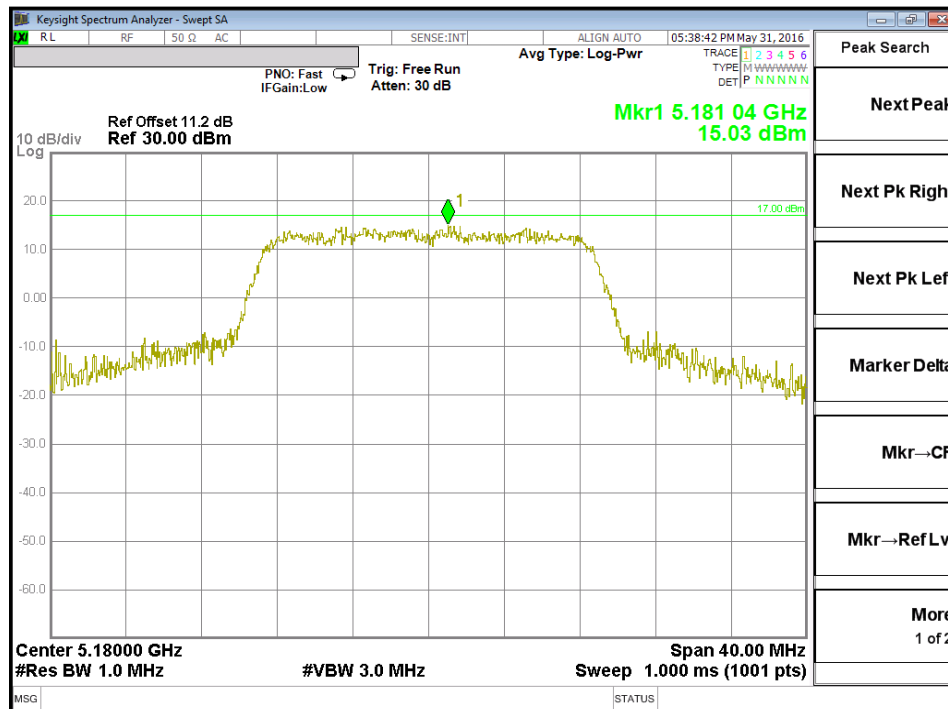
High Channel

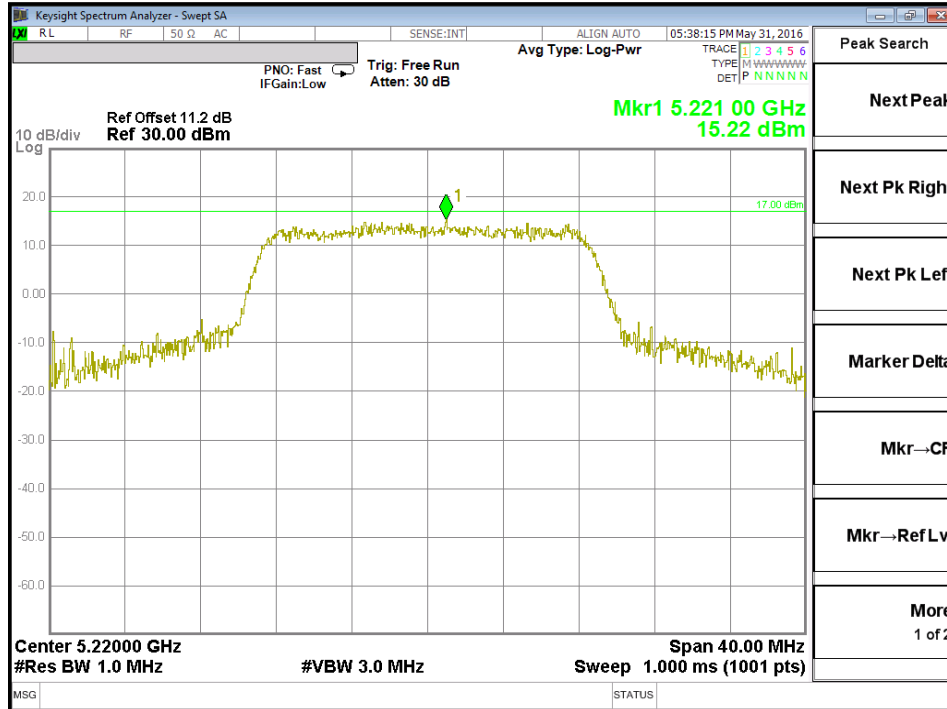
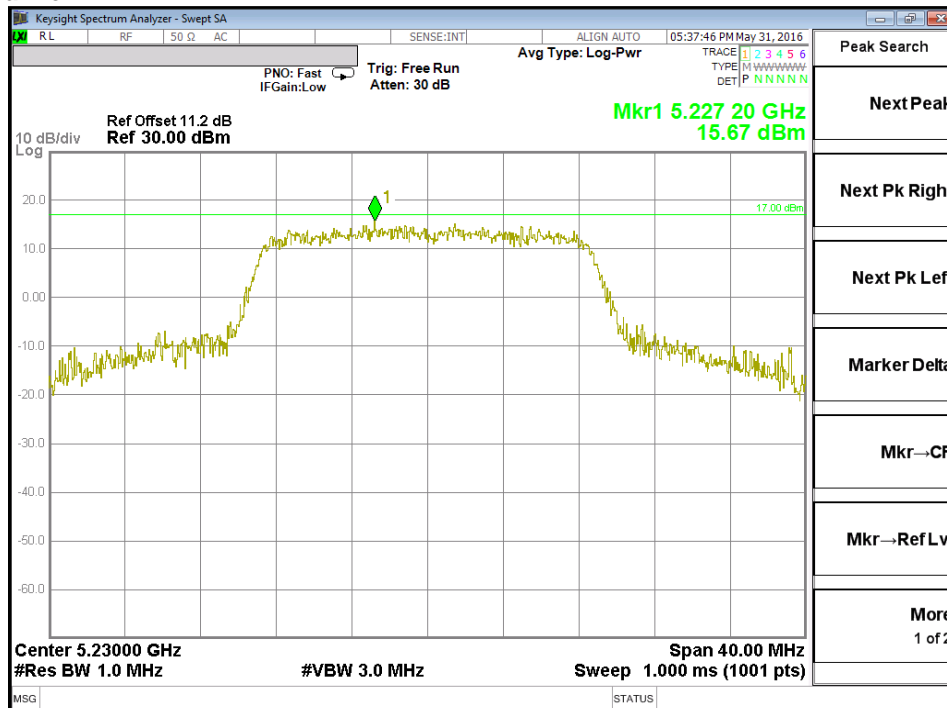
Test Plot of Power Density (HT20)
Low Channel

Middle Channel

High Channel

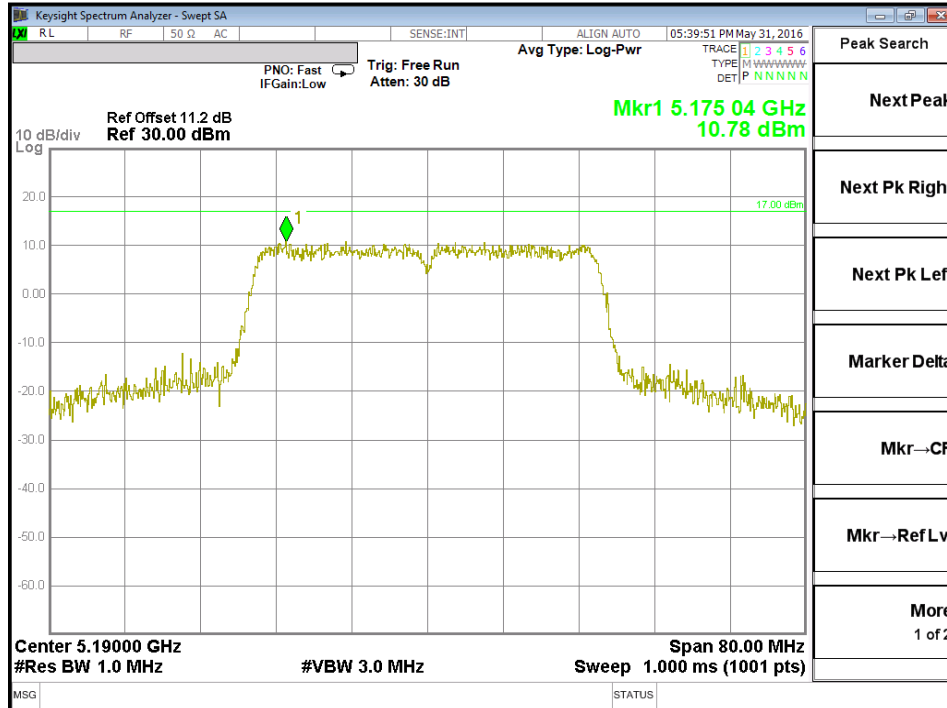
Test Plot of Power Density (HT40)

Low Channel

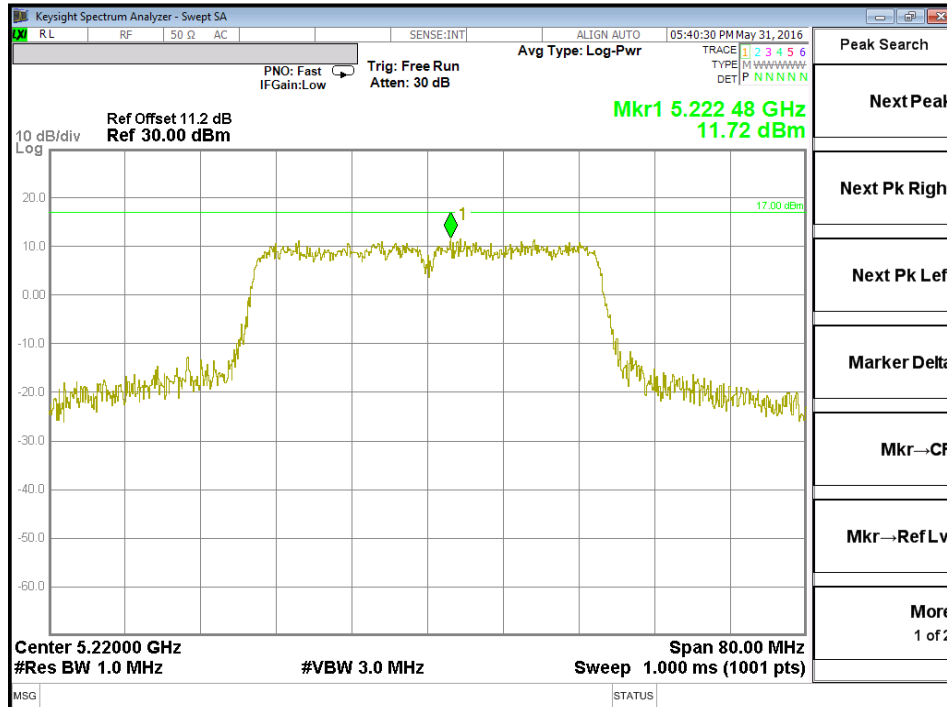

High Channel

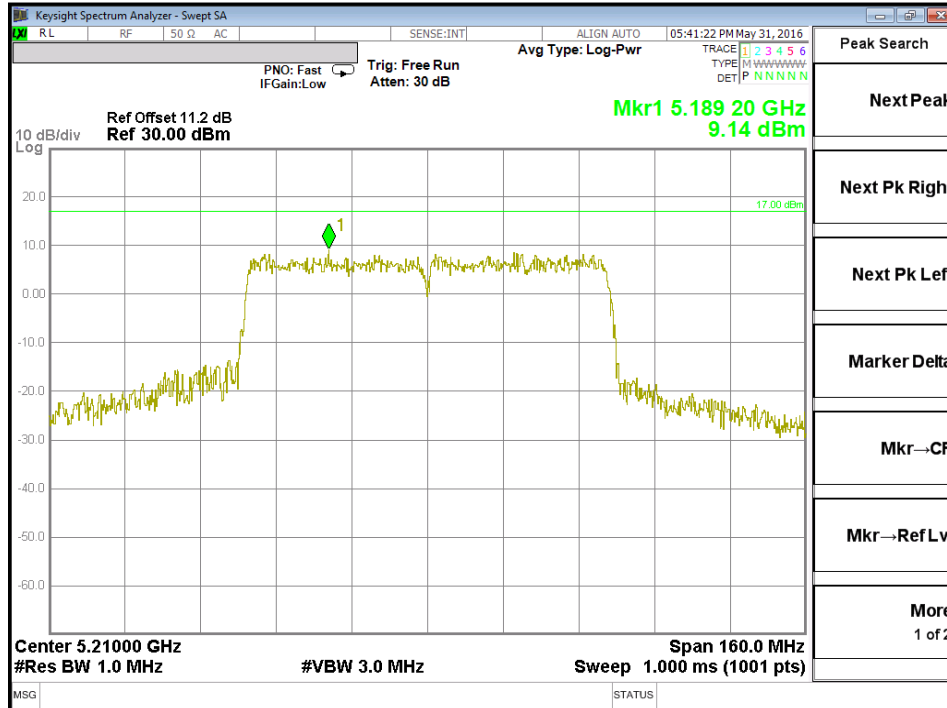
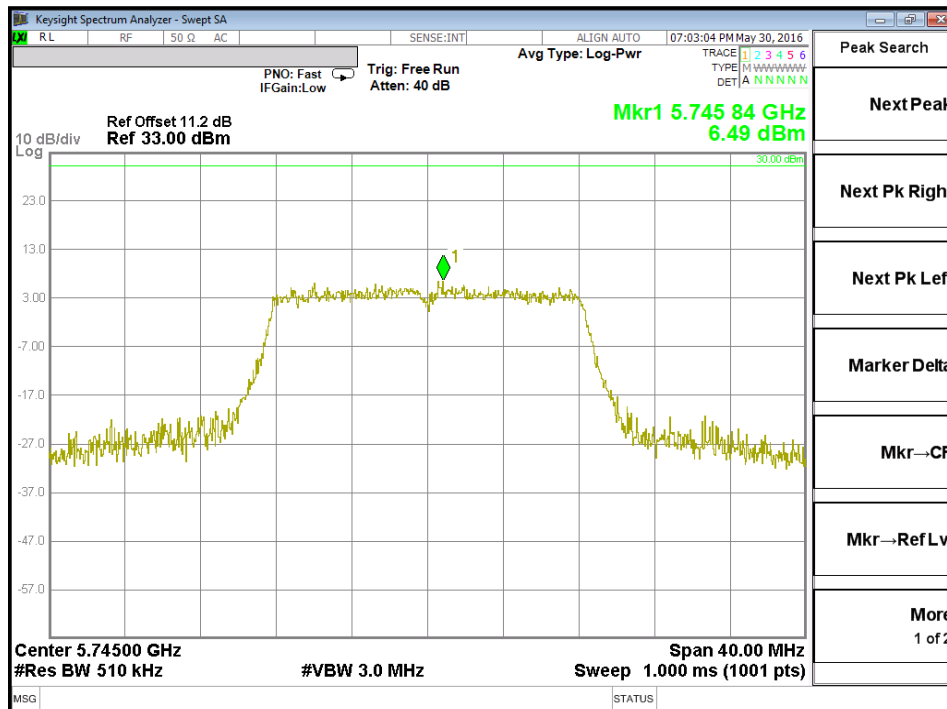

Test Plot of Power Density (HT80)
Low Channel

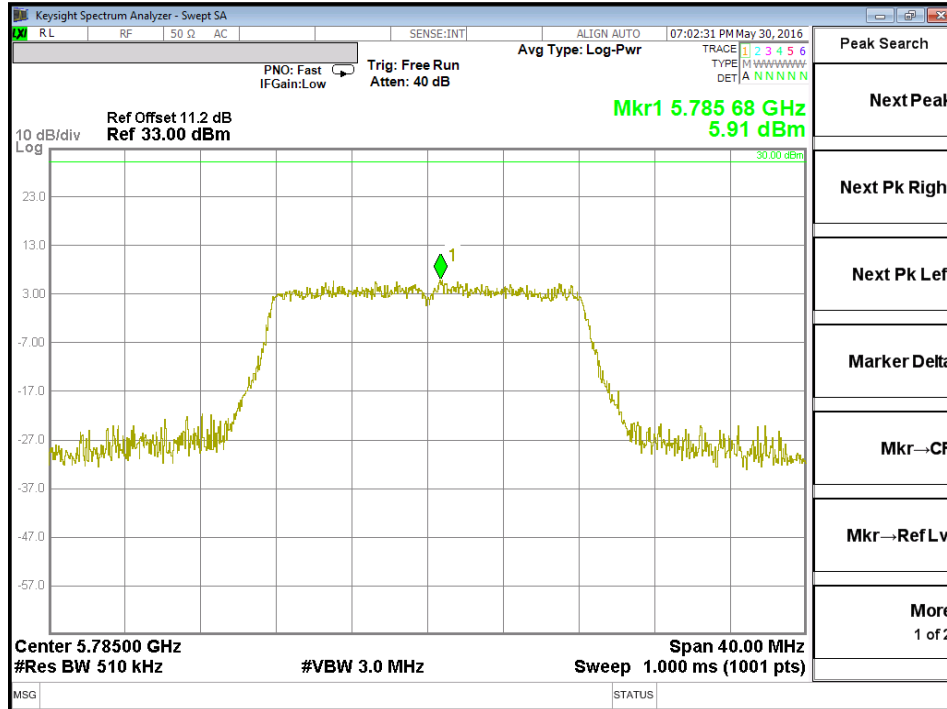
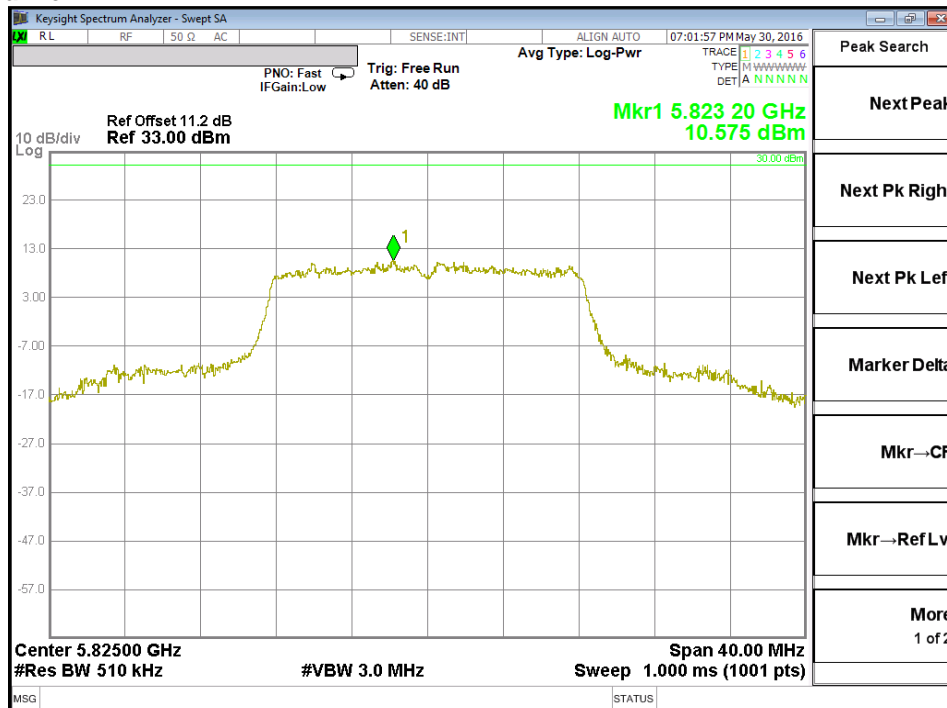
Test Plot of Power Density (5745-5850MHz)
Low Channel

Middle Channel

High Channel

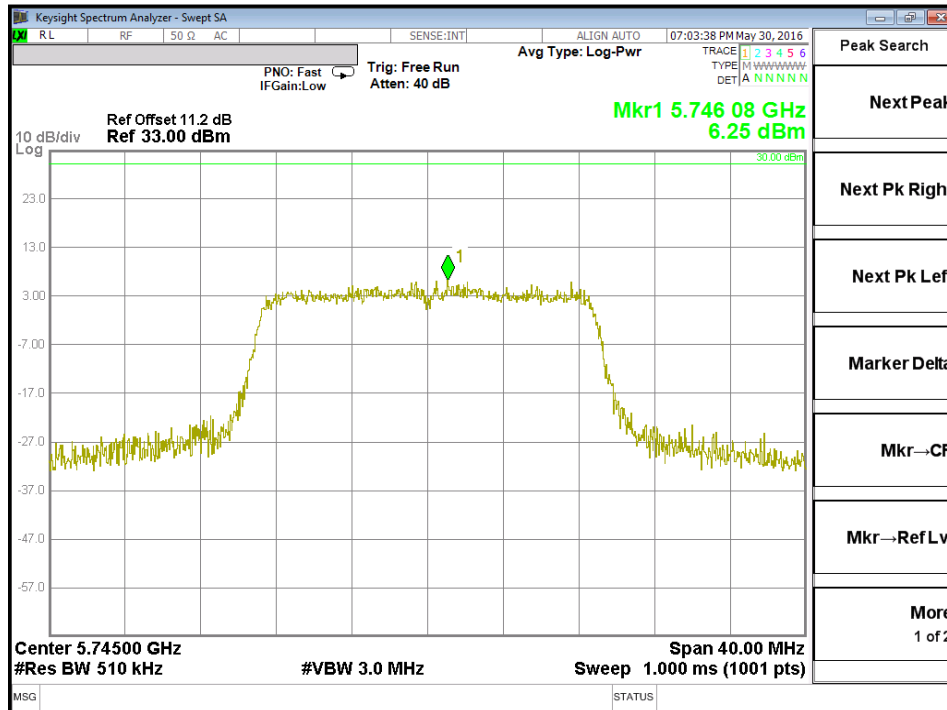
Test Plot of Power Density (HT20)

Low Channel

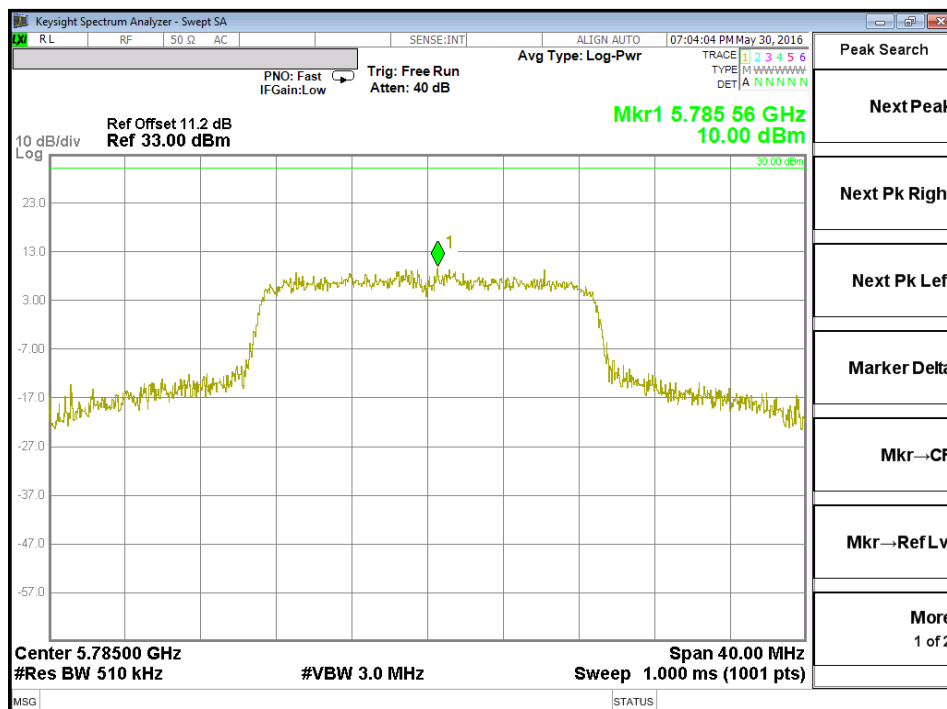

Middle Channel

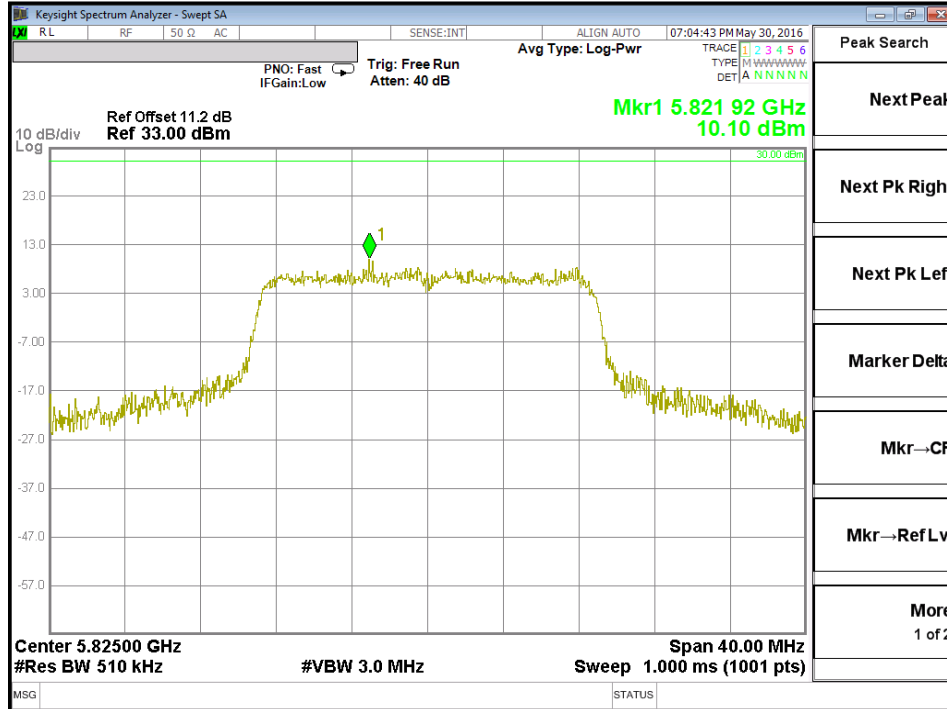
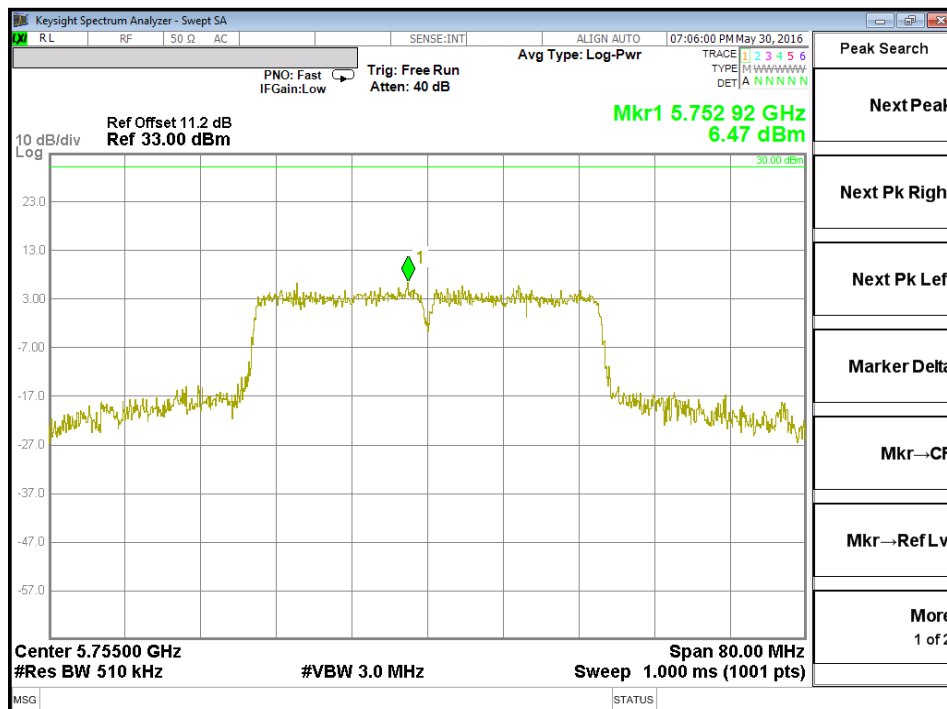

High Channel

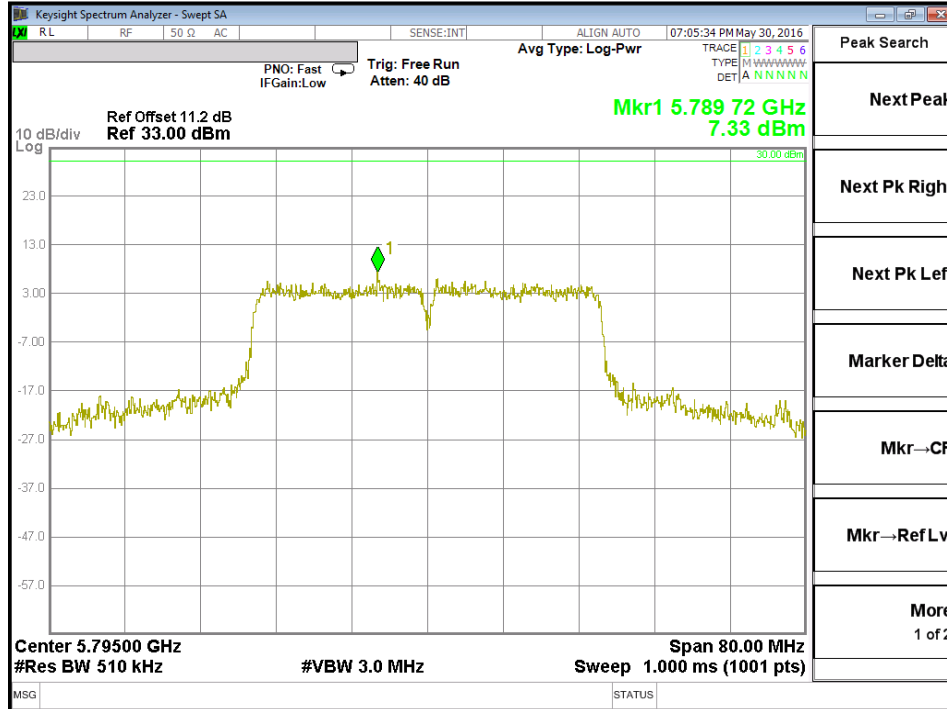
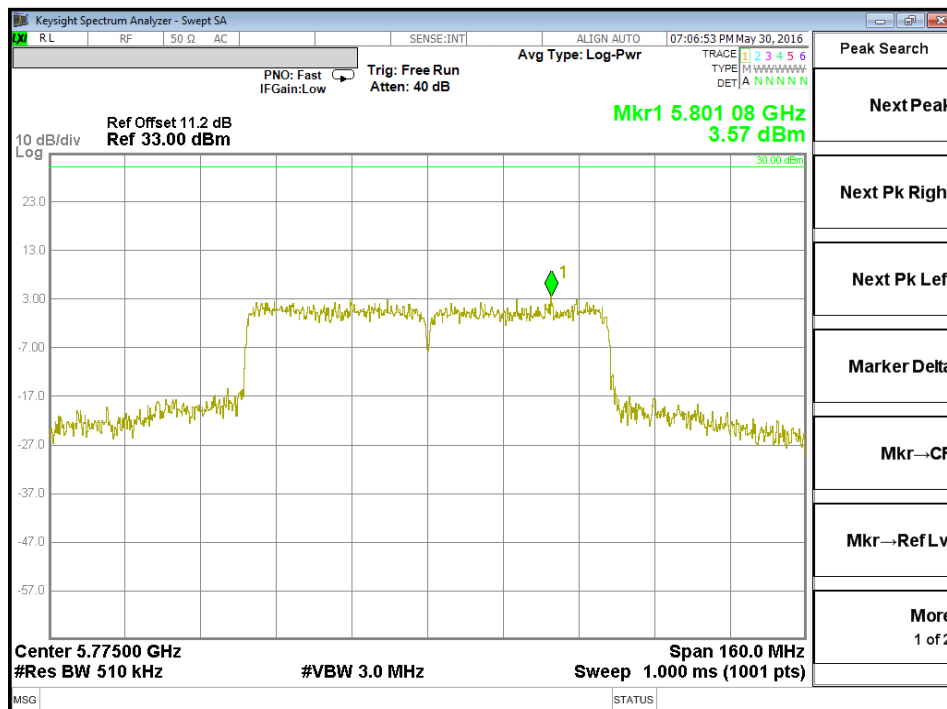
Test Plot of Power Density (HT40)
Low Channel

High Channel

Test Plot of Power Density (HT80)
Low Channel

5.1.6 Spurious Emission

RESULT:**Passed**

Test standard	:	FCC 15.205, FCC 15.209, RSS-210 2.2, RSS-210 A8.5 and RSS-Gen 7.2.1
Basic standard	:	ANSI C63.10: 2013
Limits	:	Radiated emissions which fall in the restricted bands, as defined in FCC 15.205(a) and RSS-210 2.7 (Table 1), must comply with the radiated emission limits specified in FCC 15.209(a) and RSS-210 2.7 (Table 2 and 3). Emission radiated outside the specified frequency bands must comply with the radiated emission limits specified in FCC 15.209(a) and FCC 15.407(b), RSS-210 2.7 (Table 2 and 3) and RSS-210 A2.9(a).
Kind of test site	:	3m Semi-Anechoic Chamber

Test setup

Test Channel	:	Low/ Middle/ High
Operation mode	:	A

Remark: Testing was carried out within frequency range 30MHz to the tenth harmonic. For details refer to Appendix D. The Radiated Emissions testing was performed in the X, Y and Z axis orientation. The Z Axis orientation is the worst-case and recorded in this test report. Due to the small size of the product and that there are no inductive components of significant size, 9kHz to 30MHz frequency range is not tested based on technical judgment.

5.2 Mains Emissions

5.2.1 Mains Conducted Emissions

RESULT:**Passed**

Test standard : FCC Part 15.207
FCC Part 15.107
RSS-Gen 8.8
LP0002: 2.3

Limits : Mains Conducted emissions as defined in
above standards

Kind of test site : Shielded Room

Test setup

Test Channel : Middle
Operation mode : A

Remark: For details refer to Appendix D.

Photographs of the Test Set-Up

Photograph 1: Set-up for Spurious Emissions (Front View)

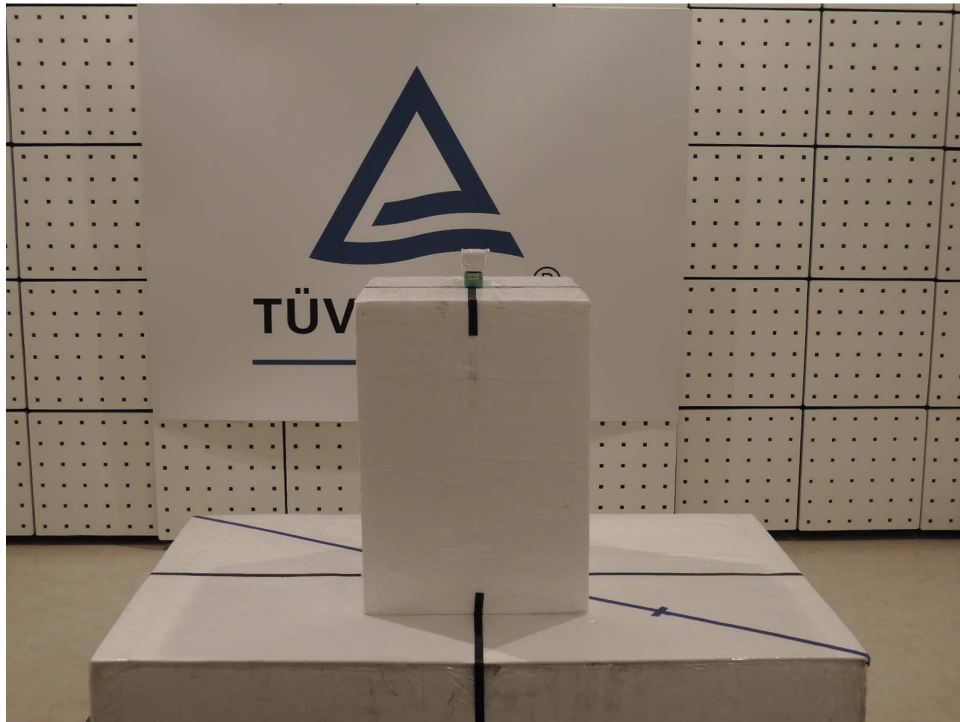

Photograph 2: Set-up for Spurious Emissions (Back View 1)

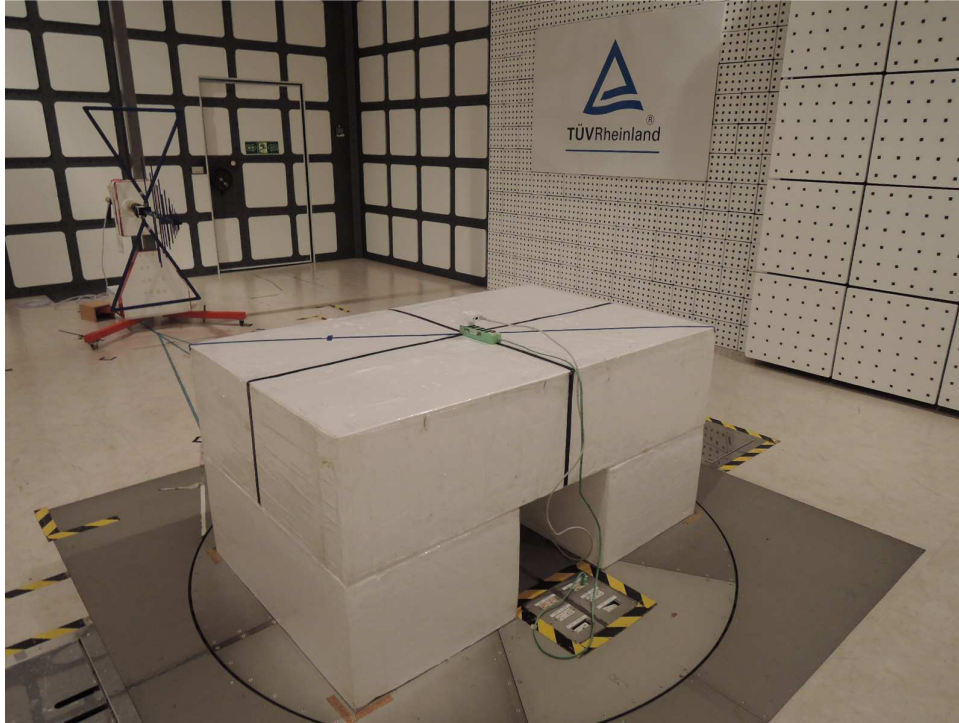

Photograph 3: Set-up for Spurious Emissions (Back View 2)

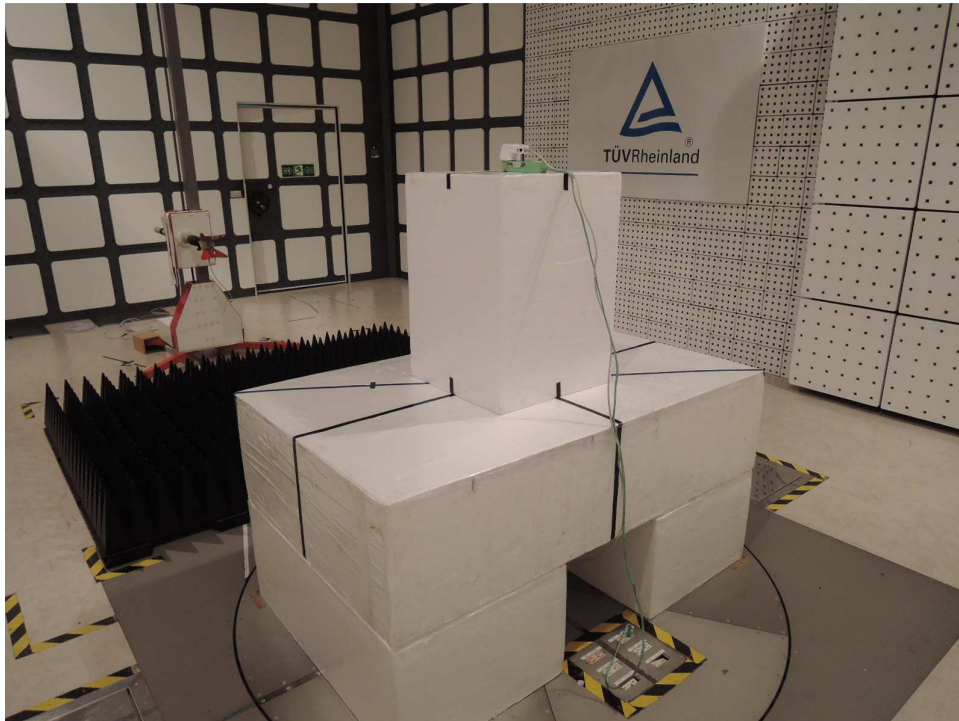

Photograph 4: Set-up for Conducted testing

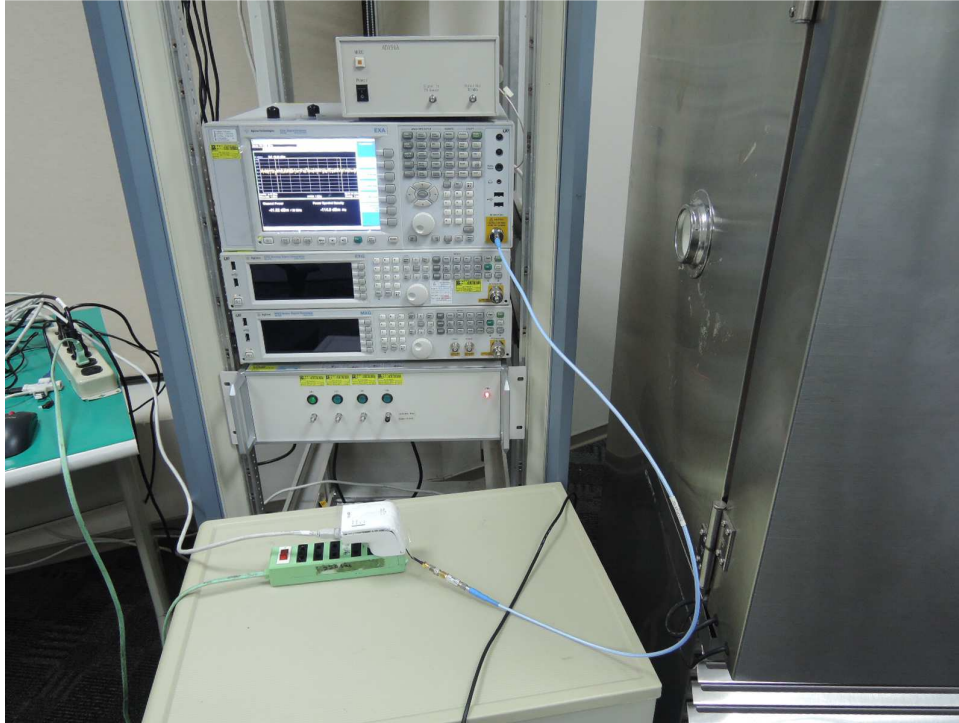

Photograph 5: Set-up for for Mains Conducted testing Back

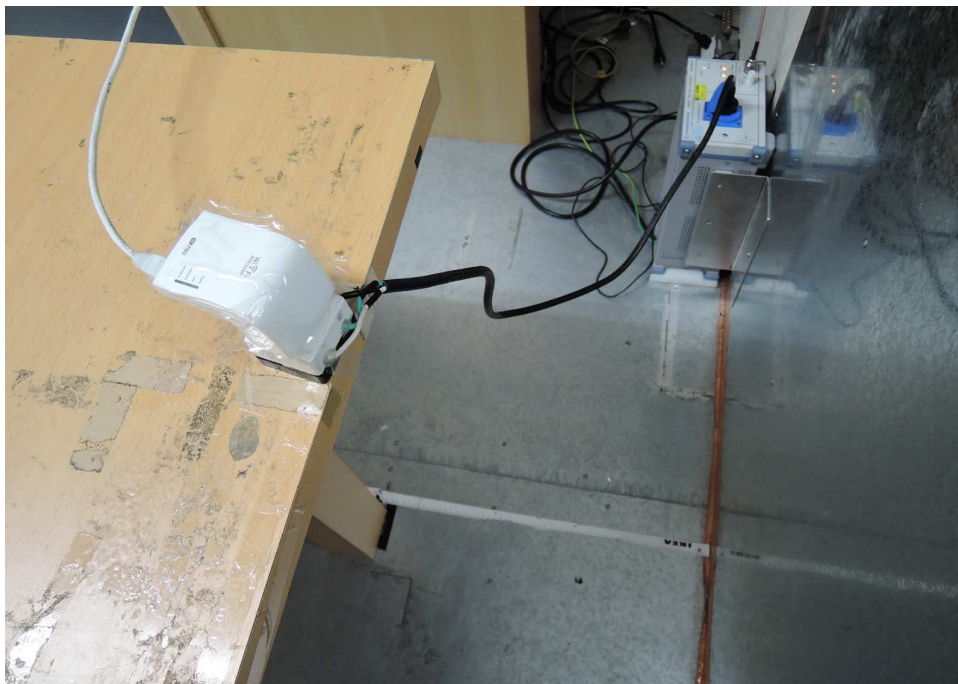

Photograph 6: Set-up for for Mains Conducted testing Front



6. List of Tables

Table 1: Applied Standard and Test Levels	5
Table 2: List of Test and Measurement Equipment	7
Table 3: Emission Measurement Uncertainty.....	8
Table 4: Technical Specification of EUT	9
Table 5: Test Channel Frequency information	10
Table 6: Test result of 26dB/99% Bandwidth (11a).....	17
Table 7: Test result of 26dB/99% Bandwidth (HT20).....	17
Table 8: Test result of 26dB/99% Bandwidth (HT40).....	18
Table 9: Test result of 26dB/99% Bandwidth (HT80).....	18
Table 10: Test result of 6dB Bandwidth and 99% Bandwidth (11a).....	24
Table 11: Test result of 6dB Bandwidth and 99% Bandwidth (HT20).....	24
Table 12: Test result of 6dB Bandwidth and 99% Bandwidth (HT40).....	25
Table 13: Test result of 6dB Bandwidth and 99% Bandwidth (HT80).....	25
Table 14: Test result of Transmit Power (11a)	32
Table 15: Test result of Transmit Power (HT20)	32
Table 16: Test result of Transmit Power (HT40)	33
Table 17: Test result of Transmit Power (HT80)	33
Table 18: Test result of Power Spectral Density (11a_5150-5250MHz).....	34
Table 19: Test result of Power Spectral Density (HT20).....	34
Table 20: Test result of Power Spectral Density (HT40).....	34
Table 21: Test result of Power Spectral Density (HT80).....	35
Table 22: Test result of Power Spectral Density (11a_5725-5850MHz).....	35
Table 23: Test result of Power Spectral Density (HT20).....	35
Table 24: Test result of Power Spectral Density (HT40).....	35
Table 25: Test result of Power Spectral Density (HT80).....	35

7. List of Photographs

Photograph 1: Set-up for Spurious Emissions (Front View).....	47
Photograph 2: Set-up for Spurious Emissions (Back View 1)	48
Photograph 3: Set-up for Spurious Emissions (Back View 2)	48
Photograph 4: Set-up for Conducted testing	49
Photograph 5: Set-up for for Mains Conducted testing Back	49
Photograph 6: Set-up for for Mains Conducted testing Front.....	50