

Water Valve

NAS-WV03B2

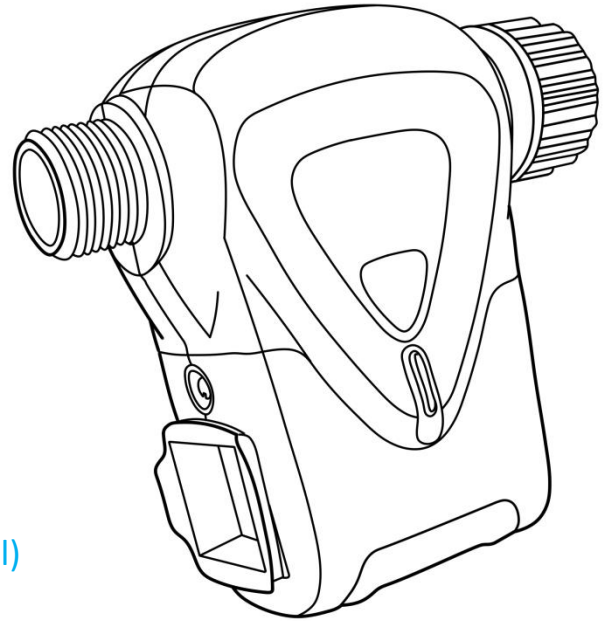

Basic parameter

Host parameter

Product name: Zigbee single irrigation switch

Power supply: AA 1.5V * 4 replaceable

Pipe size: British 3/4 inch (British, US optional)

Standby power: Off ~ 41uA

Communication protocol: Zigbee 3.0

Wireless protocol: Zigbee IEEE 802.15.4

Wireless distance: 45M

Waterproof class: IP66

Working water pressure: 0.03MPa ~ 0.9MPa

Operating temperature :1 ~ 60°C(32 ~ 140°F)

Working humidity: 1% ~ 95%RH (non-condensing)

Dimensions: 137mm X 126mm X 54mm

Flowmeter parameter

Working voltage: DC 1.8-5.5V

Working current: 10uA

Flow range: 2 to 35L/min

Operating temperature: 1 ~ 60°C(32 ~ 140°F)

Dimensions: 81mm X 46mm X 46mm

Feature description

1. Support mobile phone remote control of water valve switch
2. Supports local key switches
3. Support timing switch water valve watering
4. Support time-limited watering and quantitative watering
5. Low power reminder, APP push when the power is too low
6. Use 4 replaceable AA batteries for power supply, no wiring required, easy installation
7. Support scene linkage
8. Support family sharing, which can be controlled by multiple people
9. High waterproof level, safe to use
10. External flow sensor, real-time display of flow rate and water consumption

FCC Statement

This equipment has been tested and found to comply with the limits for a Class B digital device, pursuant to part 15 of the FCC rules. These limits are designed to provide reasonable protection against harmful interference in a residential installation. This equipment generates, uses and can radiate radio frequency energy and, if not installed and used in accordance with the instructions, may cause harmful interference to radio communications. However, there is no guarantee that interference will not occur in a particular installation. If this equipment does cause harmful interference to radio or television reception, which can be determined by turning the equipment off and on, the user is encouraged to try to correct the interference by one or more of the following measures:

- Reorient or relocate the receiving antenna.
- Increase the separation between the equipment and receiver.
- Connect the equipment into an outlet on a circuit different from that to which the receiver is connected.
- Consult the dealer or an experienced radio/TV technician for help.

To assure continued compliance, any changes or modifications not expressly approved by the party.

Responsible for compliance could void the user's authority to operate this equipment. (Example- use only shielded interface cables when connecting to computer or peripheral devices).

This equipment complies with Part 15 of the FCC Rules. Operation is subject to the following two conditions:

- (1) This device may not cause harmful interference, and
- (2) This device must accept any interference received, including interference that may cause undesired operation.

FCC Radiation Exposure Statement:

The equipment complies with FCC Radiation exposure limits set forth for uncontrolled environment. This equipment should be installed and operated with minimum distance 20cm between the radiator and your body.