

# TEST REPORT

**Applicant:** Seeed Technology Co., Ltd.  
**Address:** 9F, G3 Building, TCL International E City,  
Zhongshanyuan Road, Nanshan District, Shenzhen,  
Guangdong Province, P.R.C  
**Equipment Type:** SenseCAP Card Tracker  
**Model Name:** T1000-A (refer to section 2.4)  
**Brand Name:** Seeed Studio  
**FCC ID:** Z4T-T1000  
**Test Standard:** 47 CFR Part 15 Subpart C  
(refer to section 3.1)  
**Sample Arrival Date:** May 29, 2023  
**Test Date:** Jun. 02, 2023 - Jun. 08, 2023  
**Date of Issue:** Jul. 20, 2023

**ISSUED BY:**

Shenzhen BALUN Technology Co., Ltd.

**Tested by:** Julie Zhu

**Checked by:** Ye Hongji

**Approved by:** Liao Jianming  
(Technical Director)

*Julie Zhu*

*Ye Hongji*

*Liao Jianming*

<b>Revision History</b>		
Version	Issue Date	Revisions
<u>Rev. 01</u>	<u>Jul. 20, 2023</u>	<u>Initial Issue</u>

## TABLE OF CONTENTS

1	GENERAL INFORMATION .....	4
1.1	Test Laboratory .....	4
1.2	Test Location .....	4
2	PRODUCT INFORMATION .....	5
2.1	Applicant Information .....	5
2.2	Manufacturer Information .....	5
2.3	Factory Information .....	5
2.4	General Description for Equipment under Test (EUT) .....	5
2.5	Technical Information .....	6
3	SUMMARY OF TEST RESULTS .....	7
3.1	Test Standards .....	7
3.2	Test Verdict .....	7
4	GENERAL TEST CONFIGURATIONS .....	8
4.1	Test Environments .....	8
4.2	Test Equipment List .....	8
4.3	Measurement Uncertainty .....	9
4.4	Description of Test Setup .....	9
4.5	Measurement Results Explanation Example .....	12
5	TEST ITEMS .....	13
5.1	Antenna Requirements .....	13
5.2	Output Power .....	14
5.3	Occupied Bandwidth .....	16
5.4	Conducted Spurious Emission .....	17
5.5	Band Edge (Authorized-band band-edge) .....	19

5.6	Conducted Emission .....	21
5.7	Radiated Spurious Emission .....	22
5.8	Band Edge (Restricted-band band-edge).....	24
5.9	Power Spectral density (PSD).....	25
ANNEX A	TEST RESULT .....	26
A.1	Output Power, Duty Cycle .....	26
A.2	Occupied Bandwidth .....	30
A.3	Conducted Spurious Emissions .....	34
A.4	Band Edge (Authorized-band band-edge).....	39
A.5	Conducted Emissions.....	42
A.6	Radiated Spurious Emission .....	44
A.7	Band Edge (Restricted-band band-edge).....	68
A.8	Power Spectral Density (PSD) .....	74
ANNEX B	TEST SETUP PHOTOS .....	77
ANNEX C	EUT EXTERNAL PHOTOS .....	77
ANNEX D	EUT INTERNAL PHOTOS .....	77

# 1 GENERAL INFORMATION

## 1.1 Test Laboratory

Name	Shenzhen BALUN Technology Co., Ltd.
Address	Block B, 1/F, Baisha Science and Technology Park, Shahe Xi Road, Nanshan District, Shenzhen, Guangdong Province, P. R. China
Phone Number	+86 755 6685 0100

## 1.2 Test Location

Name	Shenzhen BALUN Technology Co., Ltd.
Location	<input checked="" type="checkbox"/> Block B, 1/F, Baisha Science and Technology Park, Shahe Xi Road, Nanshan District, Shenzhen, Guangdong Province, P. R. China
	<input type="checkbox"/> 1/F, Building B, Ganghongji High-tech Intelligent Industrial Park, No. 1008, Songbai Road, Yangguang Community, Xili Sub-district, Nanshan District, Shenzhen, Guangdong Province, P. R. China
Accreditation Certificate	The laboratory is a testing organization accredited by FCC as a accredited testing laboratory. The designation number is CN1196.

## 2 PRODUCT INFORMATION

### 2.1 Applicant Information

Applicant	Seed Technology Co., Ltd.
Address	9F, G3 Building, TCL International E City, Zhongshanyuan Road, Nanshan District, Shenzhen, Guangdong Province, P.R.C

### 2.2 Manufacturer Information

Manufacturer	Seed Technology Co., Ltd.
Address	9F, G3 Building, TCL International E City, Zhongshanyuan Road, Nanshan District, Shenzhen, Guangdong Province, P.R.C

### 2.3 Factory Information

Factory	Shenzhen Xinxian Technology Co; Limited
Address	F5, Building B17, Hengfeng Industrial City, No. 739 Zhoushi Rd, Baoan District, Shenzhen, Guangdong, P.R.C

### 2.4 General Description for Equipment under Test (EUT)

EUT Name	SenseCAP Card Tracker		
Model Name Under Test	T1000-A		
Series Model Name	T1000-B, T1000-C, T1000-D		
Description of Model name differentiation	All models are same with electrical parameters and internal circuit structure, but only differ as below (this information provided by the customer):		
	Model	Light, Temperature and Accelerometer sensor	GNSS Chip
	T1000-A	Support	AG3335
	T1000-B	Not support	AG3335
	T1000-C	Support	LR1110
	T1000-D	Not support	LR1110
Hardware Version	v1.2		
Software Version	v1.8		
Dimensions (Approx.)	N/A		
Weight (Approx.)	N/A		

## 2.5 Technical Information

Network and Wireless connectivity	Bluetooth BLE WIFI 802.11b, 802.11g, 802.11n (Only RX) LoRa, GPS, BDS, GLONASS, Galileo
-----------------------------------	---

The requirement for the following technical information of the EUT was tested in this report:

Modulation Technology	DTS
Modulation Type	LoRa
Product Type	<input type="checkbox"/> Mobile <input checked="" type="checkbox"/> Portable <input type="checkbox"/> Fix Location
Frequency Range	The frequency range used is 902 MHz to 928 MHz.
Frequency Bandwidth	500 kHz, 1523 kHz
Number of Channel	8
Tested Channel	65 (903 MHz), 68 (907.8 MHz), 72 (914.2 MHz)
Antenna Type	PCB Antenna
Antenna Gain	-0.13 dBi
Antenna System (MIMO Smart Antenna)	N/A

All channel was listed on the following table:

Channel Number	Frequency (MHz)	Channel Number	Frequency (MHz)
<b>65</b>	<b>903.0</b>	69	909.4
66	904.6	70	911.0
67	906.2	71	912.6
<b>68</b>	<b>907.8</b>	<b>72</b>	<b>914.2</b>

### 3 SUMMARY OF TEST RESULTS

#### 3.1 Test Standards

No.	Identity	Document Title
1	47 CFR Part 15, Subpart C	Intentional radiators of radio frequency equipment
2	KDB Publication 558074 D01v05r02	GUIDANCE FOR COMPLIANCE MEASUREMENTS ON DIGITAL TRANSMISSION SYSTEM, FREQUENCY HOPPING SPREAD SPECTRUM SYSTEM, AND HYBRID SYSTEM DEVICES OPERATING UNDER SECTION 15.247 OF THE FCC RULES
3	ANSI C63.10-2013	American National Standard for Testing Unlicensed Wireless Devices

#### 3.2 Test Verdict

No.	Description	FCC Part No.	Channel	Verdict
1	Antenna Requirement	15.203	--	Pass <sup>Note</sup>
2	Output Power	15.247(b)	ANNEX A.1	Pass
3	Occupied Bandwidth	15.247(a)	ANNEX A.2	Pass
4	Conducted Spurious Emission	15.247(d)	ANNEX A.3	Pass
5	Band Edge(Authorized-band band-edge)	15.247(d)	ANNEX A.4	Pass
6	Conducted Emission	15.207	ANNEX A.5	Pass
7	Radiated Spurious Emission	15.209 15.247(d)	ANNEX A.6	Pass
8	Band Edge(Restricted-band band-edge)	15.209 15.247(d)	ANNEX A.7	Pass
9	Power spectral density (PSD)	15.247(e)	ANNEX A.8	Pass

Note: The EUT has a permanently and irreplaceable attached antenna, which complies with the requirement FCC 15.203.

## 4 GENERAL TEST CONFIGURATIONS

### 4.1 Test Environments

During the measurement, the normal environmental conditions were within the listed ranges:

Relative Humidity	46% to 66%	
Atmospheric Pressure	100 kPa to 102 kPa	
Temperature	NT (Normal Temperature)	+23.0°C to +24.8°C
Working Voltage of the EUT	NV (Normal Voltage)	3.7 V

### 4.2 Test Equipment List

Description	Manufacturer	Model	Serial No.	Cal. Date	Cal. Due
Spectrum Analyzer	KEYSIGHT	N9020A	MY50330200	2023.05.16	2024.05.15
Spectrum Analyzer	ROHDE&SCHWARZ	FSV-40	101544	2022.12.28	2023.12.27
Spectrum Analyzer	KEYSIGHT	N9020A	MY52510065	2022.09.06	2023.09.05
Signaling Unit	ROHDE&SCHWARZ	CMW500	171150	2022.06.29	2023.06.28
Test Antenna-Bi-Log	SCHWARZBECK	VULB 9163	01415	2021.03.08	2024.03.07
Test Antenna-Horn	SCHWARZBECK	BBHA 9120D	01631	2022.02.03	2025.02.02
Test Antenna-Horn	A-INFO	LB-180400KF	J211060273	2021.07.02	2024.07.01
Anechoic Chamber	RAINFORD	9m*6m*6m	144	2022.02.19	2024.09.03
EMI Receiver	ROHDE&SCHWARZ	ESRP	101036	2022.09.09	2023.09.08
Test Antenna-Bi-Log	SCHWARZBECK	VULB 9168	00883	2022.04.01	2025.03.31
Test Antenna-Loop	SCHWARZBECK	FMZB 1519	1519-037	2021.04.16	2024.04.15
Anechoic Chamber	EMC Electronic Co., Ltd	20.10*11.60*7.35m	130	2021.08.15	2024.08.14
EMI Receiver	KEYSIGHT	N9010B	MY57110309	2022.09.09	2023.09.08
LISN	SCHWARZBECK	NSLK 8127	8127-687	2022.06.01	2023.05.31
LISN	SCHWARZBECK	NSLK 8127	8127-687	2023.05.16	2024.05.15
Shielded Enclosure	YiHeng Electronic Co., Ltd	3.5m*3.1m*2.8m	112	2022.02.19	2025.02.18
Amplifier	COM-MV	LSCX_LNA1-12G-01	180602	2020.09.08	2023.09.07
Amplifier	COM-MV	XKu_LNA7-18G-01	180601	2020.09.08	2023.09.07
Amplifier	COM-MV	KA_LNA18-40G-01	18050001	2020.09.08	2023.09.07
Amplifier	COM-MV	ZT30-1000M	B2017119082	2022.12.07	2023.12.06



### 4.3 Measurement Uncertainty

The following measurement uncertainty levels have been estimated for tests performed on the EUT as specified in CISPR 16-4-2.

This uncertainty represents an expanded uncertainty expressed at approximately the 95% confidence level using a coverage factor of  $k=2$ .

Parameters	Uncertainty
Occupied Channel Bandwidth	2.8%
RF output power, conducted	1.28 dB
Power Spectral Density, conducted	1.30 dB
Unwanted Emissions, conducted	1.84 dB
All emissions, radiated	5.36 dB
Temperature	0.8 °C
Humidity	4 %

### 4.4 Description of Test Setup

#### 4.4.1 For Antenna Port Test

Conducted value (dBm) = Measurement value (dBm) + cable loss (dB)

For example: the measurement value is 10 dBm and the cable 0.5dBm used, then the final result of EUT:

Conducted value (dBm) = 10 dBm + 0.5 dB = 10.5 dBm

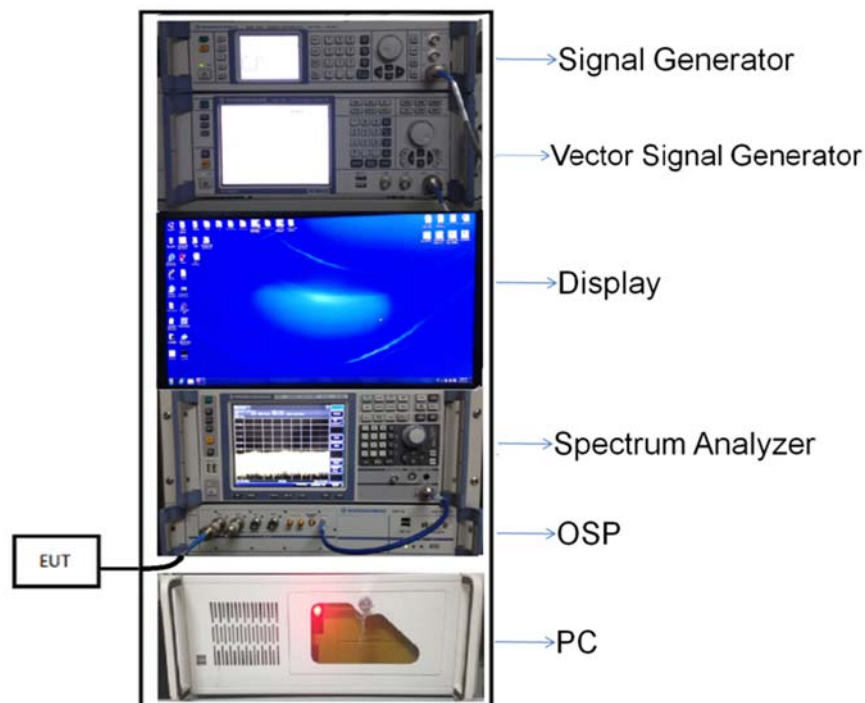

(Diagram 1)

#### 4.4.2 For AC Power Supply Port Test

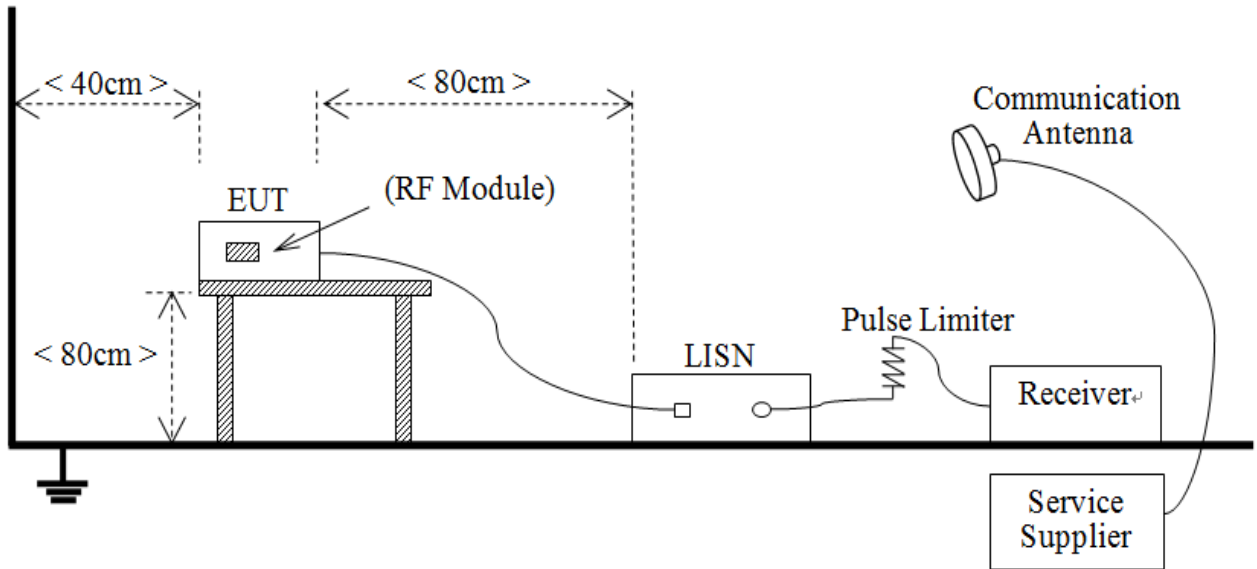

(Diagram 2)

#### 4.4.3 For Radiated Test (Below 30 MHz)

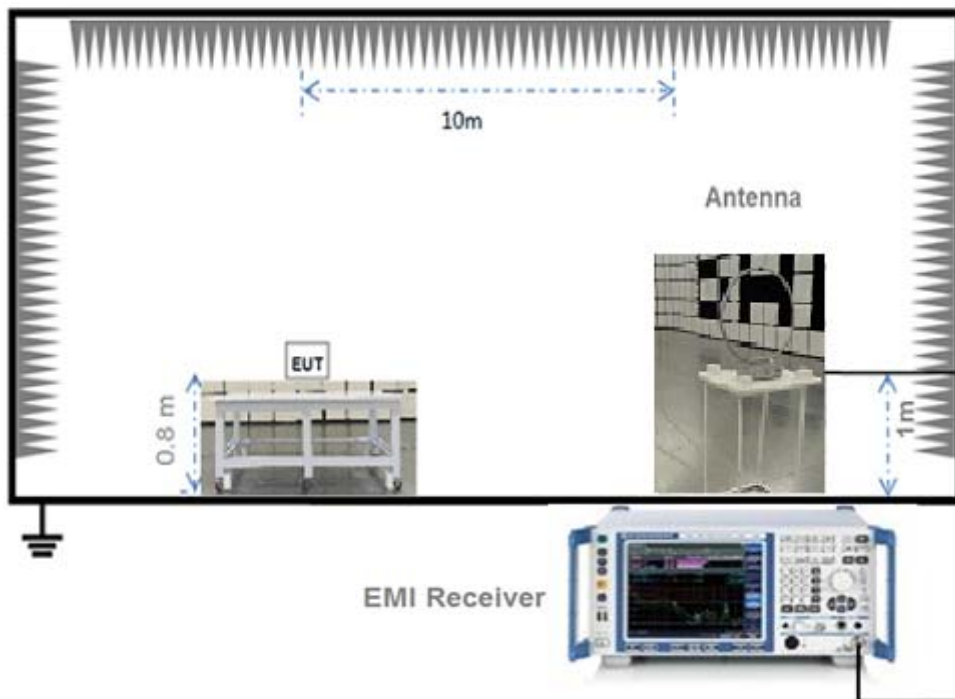

(Diagram 3)

#### 4.4.4 For Radiated Test (30 MHz-1 GHz)

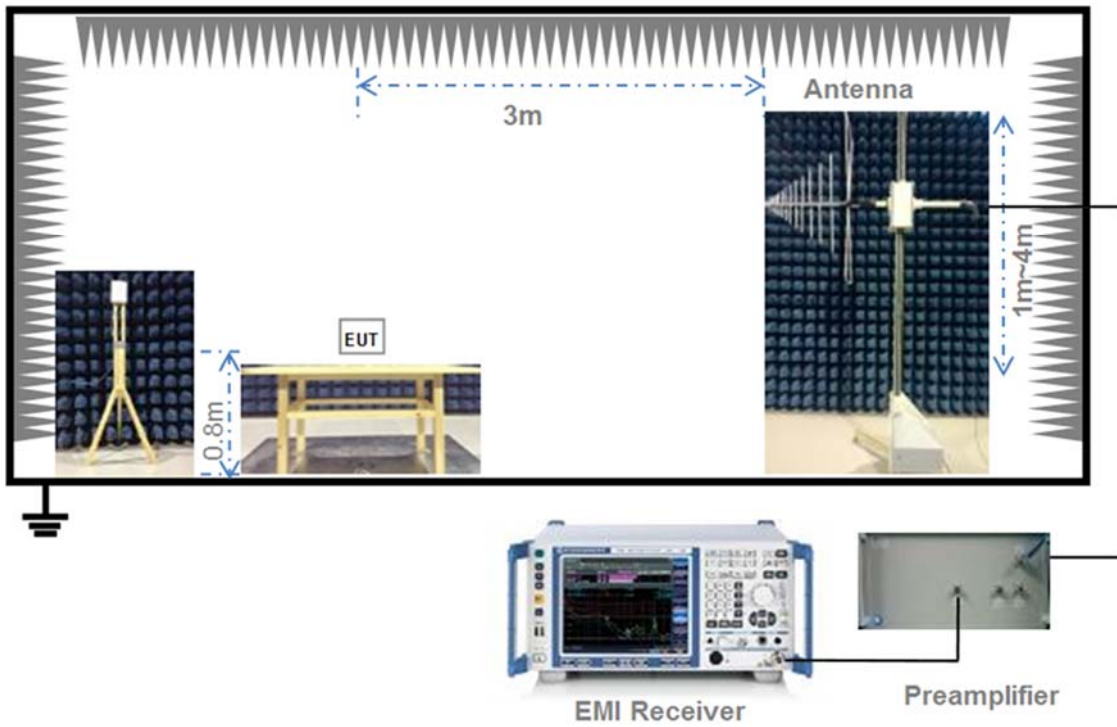

(Diagram 4)

#### 4.4.5 For Radiated Test (Above 1 GHz)

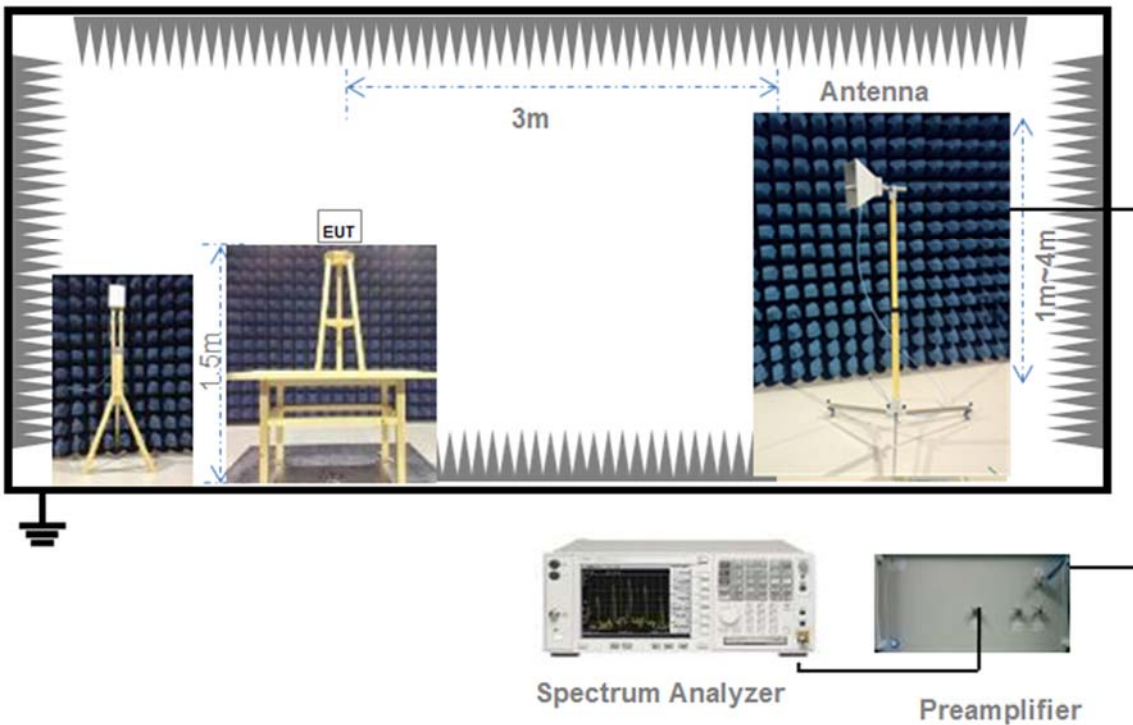

(Diagram 5)

## 4.5 Measurement Results Explanation Example

### 4.5.1 For conducted test items:

The offset level is set in the spectrum analyzer to compensate the RF cable loss and attenuator between EUT conducted output port and spectrum analyzer. With the offset compensation, the spectrum analyzer reading level is exactly the EUT RF output level.

The spectrum analyzer offset is derived from RF cable loss and attenuator factor.

Offset = RF cable loss + attenuator factor.

### 4.5.2 For radiated band edges and spurious emission test:

$$E = \text{EIRP} - 20 \log D + 104.8$$

where:

E = electric field strength in dB $\mu$ V/m,

EIRP = equivalent isotropic radiated power in dBm

D = specified measurement distance in meters.

EIRP = Measure Conducted output power Value (dBm) + Maximum transmit antenna gain (dBi) + the appropriate maximum ground reflection factor (dB)

## 5 TEST ITEMS

### 5.1 Antenna Requirements

#### 5.1.1 Relevant Standards

FCC §15.203 & 15.247(b)

An intentional radiator shall be designed to ensure that no antenna other than that furnished by the responsible party shall be used with the device. The use of a permanently attached antenna or of an antenna that uses a unique coupling to the intentional radiator shall be considered sufficient to comply with the provisions of this section. The manufacturer may design the unit so that a broken antenna can be replaced by the user, but the use of a standard antenna jack or electrical connector is prohibited. This requirement does not apply to carrier current devices or to devices operated under the provisions of § 15.211, § 15.213, § 15.217, § 15.219, or § 15.221. Further, this requirement does not apply to intentional radiators that must be professionally installed, such as perimeter protection systems and some field disturbance sensors, or to other intentional radiators which, in accordance with § 15.31(d), must be measured at the installation site. However, the installer shall be responsible for ensuring that the proper antenna is employed so that the limits in this part are not exceeded.

If directional gain of transmitting antennas is greater than 6 dBi, the power shall be reduced by the same level in dB comparing to gain minus 6 dBi. For the fixed point-to-point operation, the power shall be reduced by one dB for every 3 dB that the directional gain of the antenna exceeds 6 dBi. The use of a permanently attached antenna or of an antenna that uses a unique coupling to the intentional radiator shall be considered sufficient to comply with the FCC rule.

#### 5.1.2 Antenna Anti-Replacement Construction

The Antenna Anti-Replacement as following method:

Protected Method	Description
The antenna is embedded in the product.	An embedded-in antenna design is used.

Reference Documents	Item
Photo	Please refer to the EUT Photo documents.

#### 5.1.3 Antenna Gain

The antenna peak gain of EUT is less than 6 dBi. Therefore, it is not necessary to reduce maximum peak output power limit.

## 5.2 Output Power

### 5.2.1 Test Limit

#### FCC § 15.247(b)

For systems using digital modulation in the 902-928 MHz, 2400-2483.5 MHz, and 5725-5850 MHz bands: 1 Watt. As an alternative to a peak power measurement, compliance with the one Watt limit can be based on a measurement of the maximum conducted output power. Maximum Conducted Output Power is defined as the total transmit power delivered to all antennas and antenna elements averaged across all symbols in the signaling alphabet when the transmitter is operating at its maximum power control level. Power must be summed across all antennas and antenna elements.

### 5.2.2 Test Setup

See section 4.4.1 for test setup description for the antenna port. The photo of test setup please refer to ANNEX B.

### 5.2.3 Test Procedure

#### a) Maximum peak conducted output power

This procedure shall be used when the measurement instrument has available a resolution bandwidth that is greater than the DTS bandwidth.

Set the  $RBW \geq DTS$  bandwidth.

Set  $VBW \geq 3 \times RBW$ .

Set span  $\geq 3 \times RBW$

Sweep time = auto couple.

Detector = peak.

Trace mode = max hold.

Allow trace to fully stabilize.

Use peak marker function to determine the peak amplitude level.

#### b) Measurements of duty cycle

The zero-span mode on a spectrum analyzer or EMI receiver if the response time and spacing between bins on the sweep are sufficient to permit accurate measurements of the on and off times of the transmitted signal.

Set the center frequency of the instrument to the center frequency of the transmission.

Set  $RBW \geq OBW$  if possible; otherwise, set  $RBW$  to the largest available value.

Set  $VBW \geq RBW$ . Set detector = peak or average.

The zero-span measurement method shall not be used unless both  $RBW$  and  $VBW$  are  $> 50/T$  and the number of sweep points across duration  $T$  exceeds 100. (For example, if  $VBW$  and/or  $RBW$  are limited to 3 MHz, then the zero-span method of measuring duty cycle shall not be used if  $T \leq 16.7$  microseconds.)

## 5.2.4 Test Result

Please refer to ANNEX A.1.

## 5.3 Occupied Bandwidth

### 5.3.1 Limit

FCC §15.247(a)

Make the measurement with the spectrum analyzer's resolution bandwidth (RBW) = 100 kHz. In order to make an accurate measurement, set the span greater than RBW. The 6 dB bandwidth must be greater than 500 kHz.

### 5.3.2 Test Setup

See section 4.4.1 for test setup description for the antenna port. The photo of test setup please refer to ANNEX B.

### 5.3.3 Test Procedure

Use the following spectrum analyzer settings:

Set RBW = 100 kHz.

Set the video bandwidth (VBW)  $\geq 3$  RBW.

Detector = Peak.

Trace mode = max hold.

Sweep = auto couple.

Allow the trace to stabilize.

Measure the maximum width of the emission that is constrained by the frequencies associated with the two outermost amplitude points (upper and lower frequencies) that are attenuated by 6 dB relative to the maximum level measured in the fundamental emission.

### 5.3.4 Test Result

Please refer to ANNEX A.2.



## 5.4 Conducted Spurious Emission

### 5.4.1 Limit

FCC §15.247(d)

In any 100 kHz bandwidth outside the frequency band in which the spread spectrum or digitally modulated intentional radiator is operating, the radio frequency power that is produced by the intentional radiator shall be at least 20 dB below that in the 100 kHz bandwidth within the band that contains the highest level of the desired power, based on either an RF conducted or a radiated measurement.

### 5.4.2 Test Setup

See section 4.4.1 for test setup description for the antenna port. The photo of test setup please refer to ANNEX B.

### 5.4.3 Test Procedure

The DTS rules specify that in any 100 kHz bandwidth outside of the authorized frequency band, the power shall be attenuated according to the following conditions:

- a) If the maximum peak conducted output power procedure was used to demonstrate compliance as described in 9.1, then the peak output power measured in any 100 kHz bandwidth outside of the authorized frequency band shall be attenuated by at least 20 dB relative to the maximum in-band peak PSD level in 100 kHz (i.e., 20 dBc).
- b) If maximum conducted (average) output power was used to demonstrate compliance as described in 9.2, then the peak power in any 100 kHz bandwidth outside of the authorized frequency band shall be attenuated by at least 30 dB relative to the maximum in-band peak PSD level in 100 kHz (i.e., 30 dBc).
- c) In either case, attenuation to levels below the 15.209 general radiated emissions limits is not required.

The following procedures shall be used to demonstrate compliance to these limits. Note that these procedures can be used in either an antenna-port conducted or radiated test set-up. Radiated tests must conform to the test site requirements and utilize maximization procedures defined herein.

Reference level measurement:

Establish a reference level by using the following procedure:

Set instrument center frequency to DTS channel center frequency.

Set the span to  $\geq 1.5$  times the DTS bandwidth.

Set the RBW = 100 kHz.

Set the VBW  $\geq 3 \times$  RBW.

Detector = peak.

Sweep time = auto couple.

Trace mode = max hold.

Allow trace to fully stabilize.

Use the peak marker function to determine the maximum PSD level.

Emission level measurement:

Use the following spectrum analyzer settings:

Span = wide enough to capture the peak level of the in-band emission and all spurious emissions (e.g., harmonics) from the lowest frequency generated in the EUT up through the 10th harmonic. Typically, several plots are required to cover this entire span.

Set the RBW = 100 kHz.

Set the VBW  $\geq 3 \times$  RBW.

Detector = peak.

Sweep time = auto couple.

Trace mode = max hold.

Allow trace to fully stabilize.

Use the peak marker function to determine the maximum amplitude level.

Ensure that the amplitude of all unwanted emissions outside of the authorized frequency band (excluding restricted frequency bands) are attenuated by at least the minimum requirements specified in 11.1 a) or 11.1 b). Report the three highest emissions relative to the limit.

#### 5.4.4 Test Result

Please refer to ANNEX A.3.

## 5.5 Band Edge (Authorized-band band-edge)

### 5.5.1 Limit

#### FCC §15.247(d)

In any 100 kHz bandwidth outside the frequency band in which the spread spectrum or digitally modulated intentional radiator is operating, the radio frequency power that is produced by the intentional radiator shall be at least 20 dB below that in the 100 kHz bandwidth within the band that contains the highest level of the desired power, based on either an RF conducted or a radiated measurement.

### 5.5.2 Test Setup

See section 4.4.1 for test setup description for the antenna port. The photo of test setup please refer to ANNEX B.

### 5.5.3 Test Procedure

The following procedures may be used to determine the peak or average field strength or power of an unwanted emission that is within 2 MHz of the authorized band edge. If a peak detector is utilized, use the procedure described in 13.2.1. Use the procedure described in 13.2.2 when using an average detector and the EUT can be configured to transmit continuously (i.e., duty cycle  $\geq 98\%$ ). Use the procedure described in 13.2.3 when using an average detector and the EUT cannot be configured to transmit continuously but the duty cycle is constant (i.e., duty cycle variations are less than  $\pm 2$  percent). Use the procedure described in 13.2.4 when using an average detector for those cases where the EUT cannot be configured to transmit continuously and the duty cycle is not constant (duty cycle variations equal or exceed 2 percent).

When using a peak detector to measure unwanted emissions at or near the band edge (within 2 MHz of the authorized band), the following integration procedure can be used.

Set instrument center frequency to the frequency of the emission to be measured (must be within 2 MHz of the authorized band edge).

Set span to 2 MHz

RBW = 100 kHz.

VBW  $\geq 3 \times$  RBW.

Detector = peak.

Sweep time = auto.

Trace mode = max hold.

Allow sweep to continue until the trace stabilizes (required measurement time may increase for low duty cycle applications)

Compute the power by integrating the spectrum over 1 MHz using the analyzer's band power measurement function with band limits set equal to the emission frequency (femission)  $\pm 0.5$  MHz. If the instrument does not have a band power function, then sum the amplitude levels (in power units) at 100 kHz intervals extending across the 1 MHz spectrum defined by femission  $\pm 0.5$  MHz.

#### 5.5.4 Test Result

Please refer to ANNEX A.4.

## 5.6 Conducted Emission

### 5.6.1 Limit

#### FCC §15.207

For an intentional radiator that is designed to be connected to the public utility (AC) power line, the radio frequency voltage that is conducted back onto the AC power line on any frequency within the band 150 kHz to 30 MHz shall not exceed the limits in the following table, as measured using a 50 $\mu$ H/50 $\Omega$  line impedance stabilization network (LISN).

Frequency range (MHz)	Conducted Limit (dB $\mu$ V)	
	Quai-peak	Average
0.15 - 0.50	66 to 56	56 to 46
0.50 - 5	56	46
0.50 - 30	60	50

### 5.6.2 Test Setup

See section 4.4.2 for test setup description for the AC power supply port. The photo of test setup please refer to ANNEX B.

### 5.6.3 Test Procedure

The maximum conducted interference is searched using Peak (PK), if the emission levels more than the AV and QP limits, and that have narrow margins from the AV and QP limits will be re-measured with AV and QP detectors. Tests for both L phase and N phase lines of the power mains connected to the EUT are performed. Refer to recorded points and plots below.

Devices subject to Part 15 must be tested for all available U.S. voltages and frequencies (such as a nominal 120 VAC, 50/60 Hz and 240 VAC, 50/60 Hz) for which the device is capable of operation. A device rated for 50/60 Hz operation need not be tested at both frequencies provided the radiated and line conducted emissions are the same at both frequencies.

### 5.6.4 Test Result

Please refer to ANNEX A.5.

## 5.7 Radiated Spurious Emission

### 5.7.1 Limit

FCC §15.209&15.247(d)

Radiated emission outside the frequency band attenuation below the general limits specified in FCC section 15.209(a) is not required. In addition, radiated emissions which fall in the restricted bands, as defined in FCC section 15.205(a), must also comply with the radiated emission limits specified in FCC section 15.209(a).

According to FCC section 15.209 (a), except as provided elsewhere in this subpart, the emissions from an intentional radiator shall not exceed the field strength levels specified in the following table:

Frequency (MHz)	Field Strength ( $\mu\text{V}/\text{m}$ )	Measurement Distance (m)
0.009 - 0.490	2400/F(kHz)	300
0.490 - 1.705	24000/F(kHz)	30
1.705 - 30.0	30	30
30 - 88	100	3
88 - 216	150	3
216 - 960	200	3
Above 960	500	3

Note:

1. Field Strength (dB $\mu\text{V}/\text{m}$ ) =  $20 \cdot \log[\text{Field Strength } (\mu\text{V}/\text{m})]$ .
2. In the emission tables above, the tighter limit applies at the band edges.
3. For Above 1000 MHz, the emission limit in this paragraph is based on measurement instrumentation employing an average detector, measurement using instrumentation with a peak detector function, corresponding to 20dB above the maximum permitted average limit.
4. For above 1000 MHz, limit field strength of harmonics: 54dBuV/m@3m (AV) and 74dBuV/m@3m (PK).

### 5.7.2 Test Setup

See section 4.4.3 to 4.4.5 for test setup description for the antenna port. The photo of test setup please refer to ANNEX B.

### 5.7.3 Test Procedure

The measurement frequency range is from 9 kHz to the 10th harmonic of the fundamental frequency. The Turn Table is actuated to turn from 0° to 360°, and both horizontal and vertical polarizations of the Test Antenna are used to find the maximum radiated power. Mid channels on all channel bandwidth verified. Only the worst RB size/offset presented.

The power of the EUT transmitting frequency should be ignored.

All Spurious Emission tests were performed in X, Y, Z axis direction. And only the worst axis test condition was recorded in this test report.

Use the following spectrum analyzer settings:

Span = wide enough to fully capture the emission being measured

RBW = 1 MHz for  $f \geq 1$  GHz, 100 kHz for  $f < 1$  GHz

VBW  $\geq$  RBW

Sweep = auto

Detector function = peak

Trace = max hold

For measurement below 1GHz, If the emission level of the EUT measured by the peak detector is 3 dB lower than the applicable limit, the peak emission level will be reported, Otherwise, the emission measurement will be repeated using the quasi-peak detector and reported.

#### 5.7.4 Test Result

Please refer to ANNEX A.6.

## 5.8 Band Edge (Restricted-band band-edge)

### 5.8.1 Limit

FCC §15.209&15.247(d)

Radiated emission outside the frequency band attenuation below the general limits specified in FCC section 15.209(a) is not required. In addition, radiated emissions which fall in the restricted bands, as defined in FCC section 15.205(a), must also comply with the radiated emission limits specified in FCC section 15.209(a).

### 5.8.2 Test Setup

See section 4.4.3 to 4.4.5 for test setup description for the antenna port. The photo of test setup please refer to ANNEX B.

### 5.8.3 Test Procedure

The measurement frequency range is from 9 kHz to the 10th harmonic of the fundamental frequency. The Turn Table is actuated to turn from 0° to 360°, and both horizontal and vertical polarizations of the Test Antenna are used to find the maximum radiated power. Mid channels on all channel bandwidth verified. Only the worst RB size/offset presented.

The power of the EUT transmitting frequency should be ignored.

All Spurious Emission tests were performed in X, Y, Z axis direction. And only the worst axis test condition was recorded in this test report.

Use the following spectrum analyzer settings:

Span = wide enough to fully capture the emission being measured

RBW = 1 MHz for  $f \geq 1$  GHz, 100 kHz for  $f < 1$  GHz

VBW  $\geq$  RBW

Sweep = auto

Detector function = peak

Trace = max hold

For measurement below 1GHz, If the emission level of the EUT measured by the peak detector is 3 dB lower than the applicable limit, the peak emission level will be reported, Otherwise, the emission measurement will be repeated using the quasi-peak detector and reported.

For transmitters operating above 1 GHz repeat the measurement with an average detector.

### 5.8.4 Test Result

Please refer to ANNEX A.7.



## 5.9 Power Spectral density (PSD)

### 5.9.1 Limit

#### FCC §15.247(e)

The same method of determining the conducted output power shall be used to determine the power spectral density. If a peak output power is measured, then a peak power spectral density measurement is required. If an average output power is measured, then an average power spectral density measurement should be used.

The transmitter power spectral density conducted from the transmitter to the antenna shall not be greater than 8 dBm in any 3 kHz band during any time interval of continuous transmission. This power spectral density shall be determined in accordance with the provisions of Section 5.4(4), (i.e. the power spectral density shall be determined using the same method as is used to determine the conducted output power).

### 5.9.2 Test Setup

See section 4.4.1 (Diagram 1) for test setup description for the antenna port. The photo of test setup please refer to ANNEX B.

### 5.9.3 Test Procedure

Set analyzer center frequency to DTS channel center frequency.

Set the span to 1.5 times the DTS bandwidth.

Set the RBW to:  $3 \text{ kHz} \leq \text{RBW} \leq 100 \text{ kHz}$ .

Set the VBW  $\geq 3$  RBW.

Detector = peak.

Sweep time = auto couple.

Trace mode = max hold.

Allow trace to fully stabilize.

Use the peak marker function to determine the maximum amplitude level within the RBW.

If measured value exceeds limit, reduce RBW (no less than 3 kHz) and repeat.

### 5.9.4 Test Result

Please refer to ANNEX A.8.

## ANNEX A TEST RESULT

### A.1 Output Power, Duty Cycle

#### Peak Power Test Data

Channel	Measured Output Peak Power		Limit		Verdict
	LoRa (500kHz)		dBm	mW	
	dBm	mW			
Low	20.42	110.03	30	1000	Pass
Middle	20.28	106.71			Pass
High	20.15	103.47			Pass

Channel	Measured Output Peak Power		Limit		Verdict
	LoRa (1523kHz)		dBm	mW	
	dBm	mW			
Low	20.31	107.47	30	1000	Pass
Middle	20.22	105.24			Pass
High	20.07	101.60			Pass

Test Plots

LoRa (500kHz) LOW CHANNEL

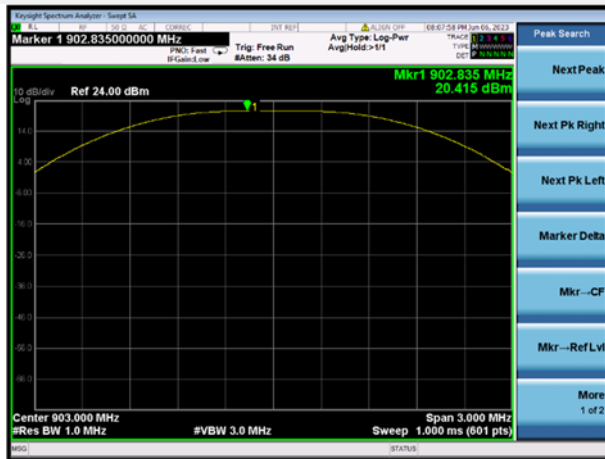

LoRa (500kHz) MIDDLE CHANNEL

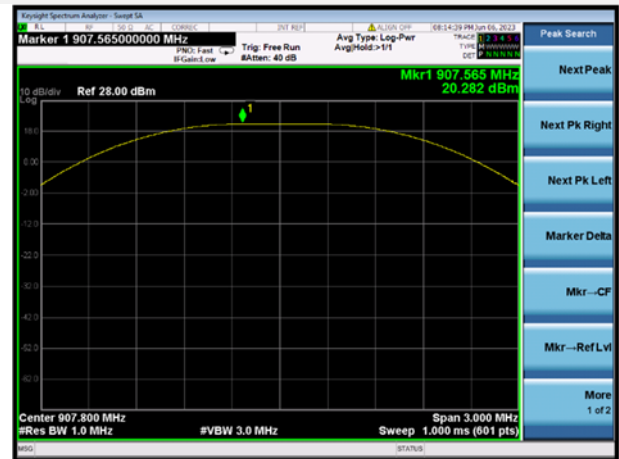

LoRa (500kHz) HIGH CHANNEL

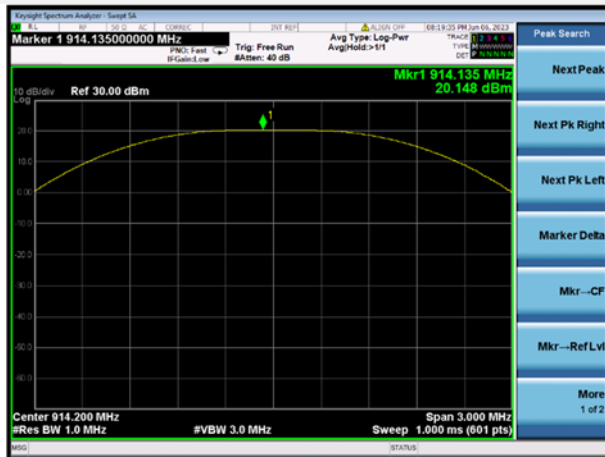

LoRa (1523kHz) LOW CHANNEL

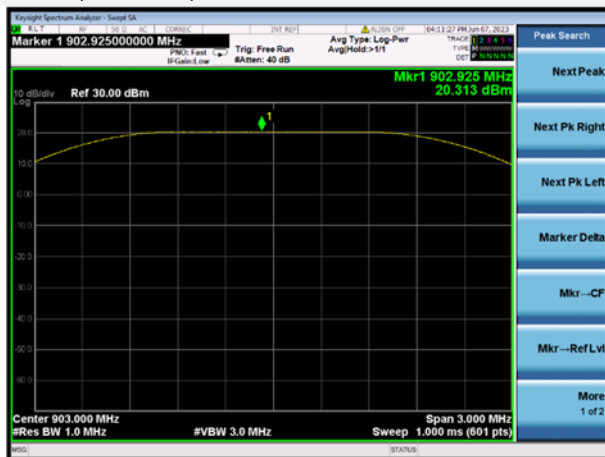

LoRa (1523kHz) MIDDLE CHANNEL

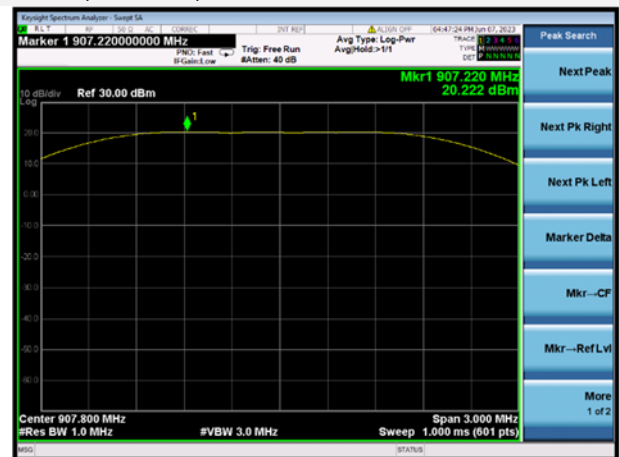

### LoRa (1523kHz) HIGH CHANNEL



**Duty Cycle Test Data**

Band	On Time (ms)	On+Off Time (ms)	Duty Cycle (%)
LoRa (500kHz)	97.6	219.7	44.42%
LoRa (1523kHz)	570.6	2608.0	21.88%

**Test Plots**

LoRa (1523kHz)

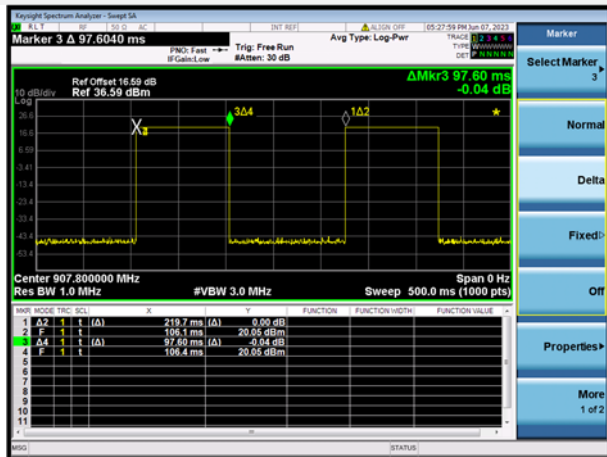

LoRa (1523kHz)

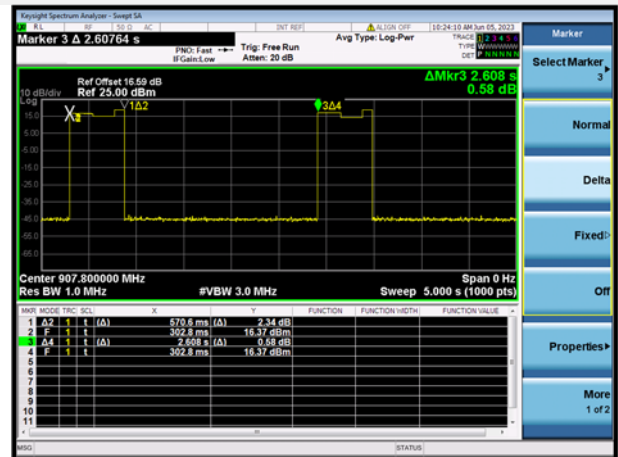

## A.2 Occupied Bandwidth

### Test Data

Test Mode	LoRa (500kHz)		
Channel	6 dB Bandwidth (kHz)	99% Bandwidth (kHz)	6 dB Bandwidth Limits (kHz)
Low Channel	645.000	546.820	≥500
Middle Channel	650.000	548.710	≥500
High Channel	650.000	550.700	≥500

Test Mode	LoRa (1523kHz)		
Channel	6 dB Bandwidth (kHz)	99% Bandwidth (kHz)	6 dB Bandwidth Limits (kHz)
Low Channel	1625.000	1525.200	≥500
Middle Channel	1625.000	1525.300	≥500
High Channel	1625.000	1525.200	≥500

Test Plots

6 dB Bandwidth

LoRa (500kHz) LOW CHANNEL

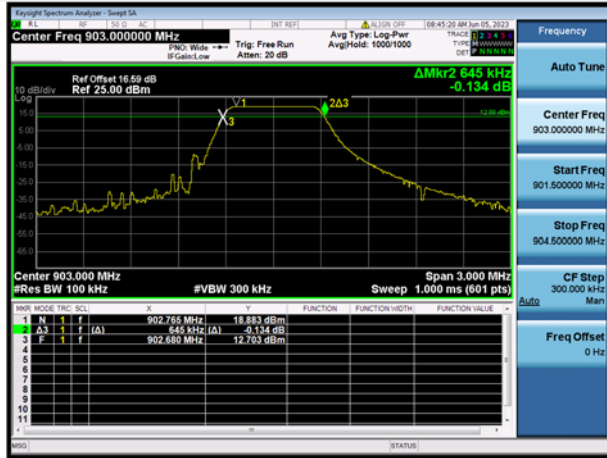

LoRa (500kHz) MIDDLE CHANNEL



LoRa (500kHz) HIGH CHANNEL

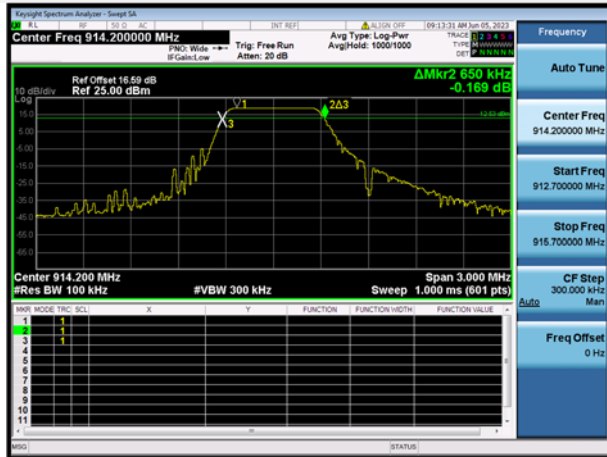

LoRa (1523kHz) LOW CHANNEL

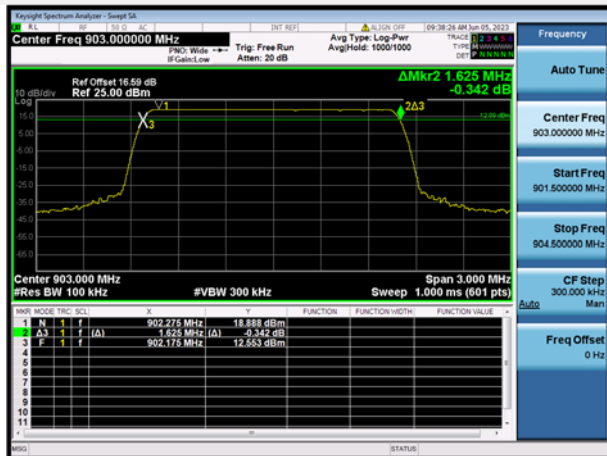

LoRa (1523kHz) MIDDLE CHANNEL

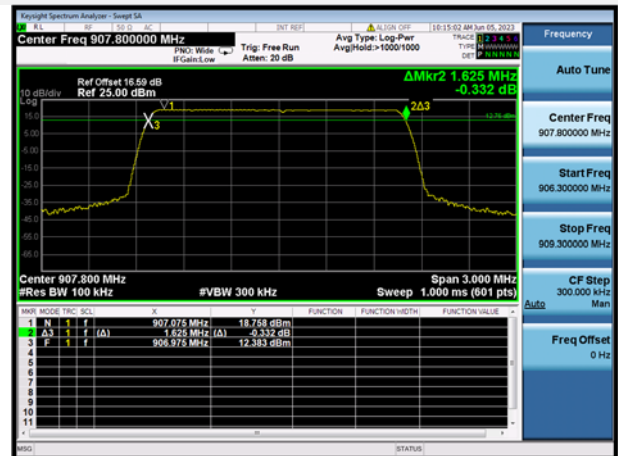

### LoRa (1523kHz) HIGH CHANNEL

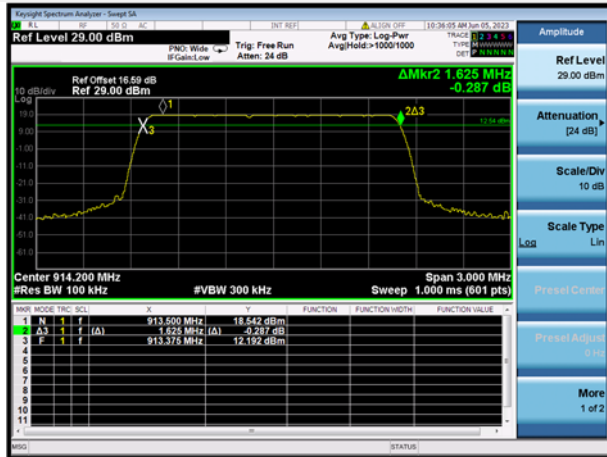

### 99% Bandwidth

#### LoRa (500kHz) LOW CHANNEL

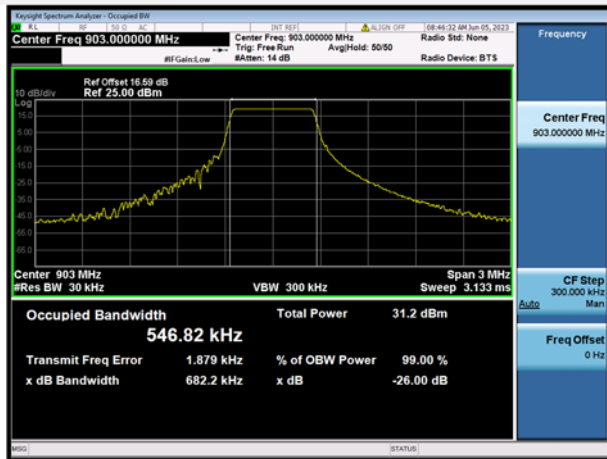

#### LoRa (500kHz) MIDDLE CHANNEL

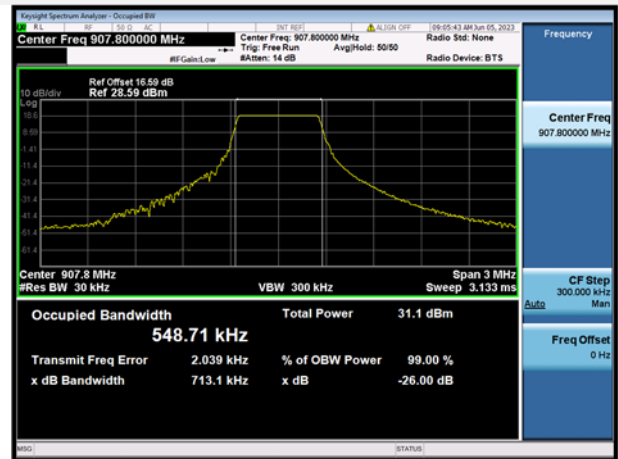

#### LoRa (500kHz) HIGH CHANNEL

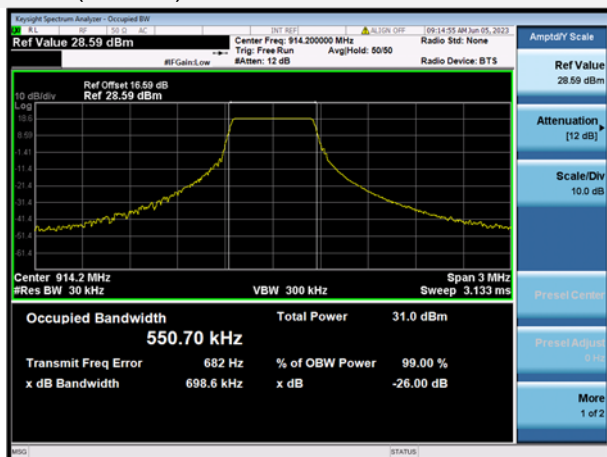



LoRa (1523kHz) LOW CHANNEL



LoRa (1523kHz) MIDDLE CHANNEL

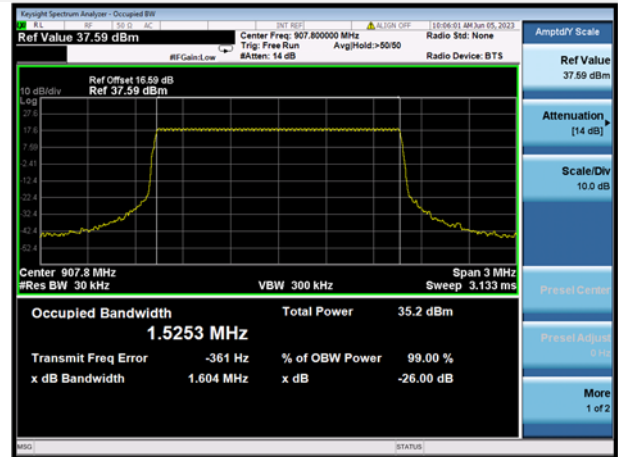

LoRa (1523kHz) HIGH CHANNEL



### A.3 Conducted Spurious Emissions

#### Test Data

LoRa (500kHz)				
Channel	Measured Max. Out of Band Emission (dBm)	Limit (dBm)		Verdict
		Carrier Level	Calculated 20 dBc Limit	
Low	-14.38	20.40	0.40	Pass
Middle	-15.05	20.30	0.30	Pass
High	-14.51	20.16	0.16	Pass

LoRa (1523kHz)				
Channel	Measured Max. Out of Band Emission (dBm)	Limit (dBm)		Verdict
		Carrier Level	Calculated 20 dBc Limit	
Low	-13.68	20.23	0.23	Pass
Middle	-14.97	20.14	0.14	Pass
High	-14.15	19.99	-0.01	Pass

Test Plots

LoRa (500kHz) LOW CHANNEL, CARRIER LEVEL

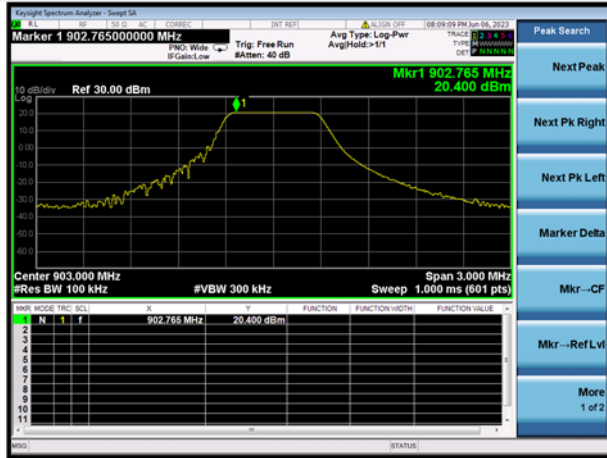

LoRa (500kHz) LOW CHANNEL, SPURIOUS 30 MHz ~ 3 GHz

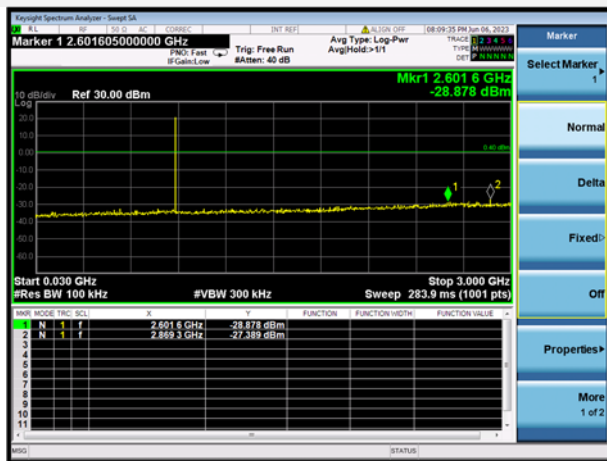

LoRa (500kHz) LOW CHANNEL, SPURIOUS 2 GHz ~ 25 GHz

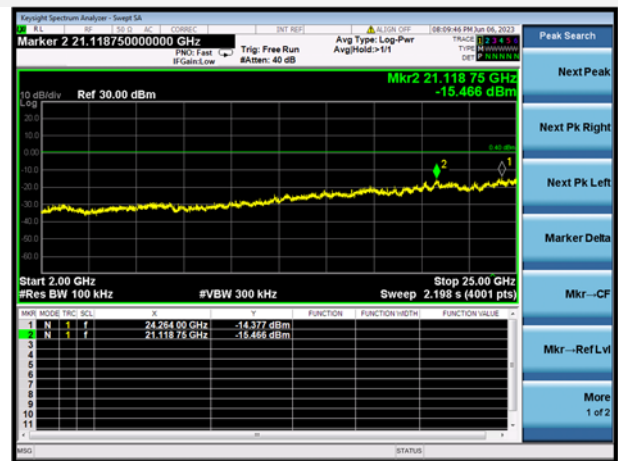

LoRa (500kHz) MIDDLE CHANNEL, CARRIER LEVEL

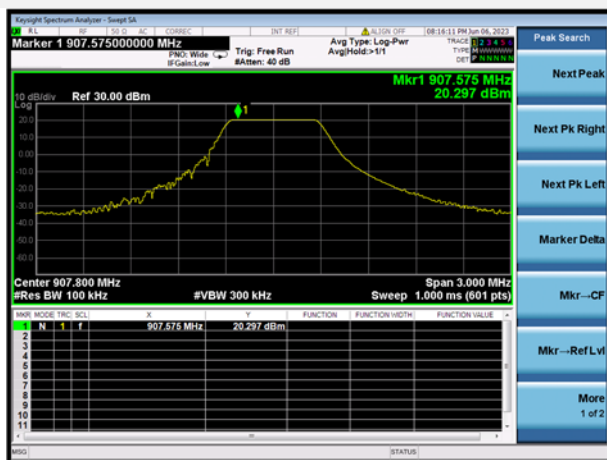

LoRa (500kHz) MIDDLE CHANNEL, SPURIOUS 30 MHz ~ 3 GHz

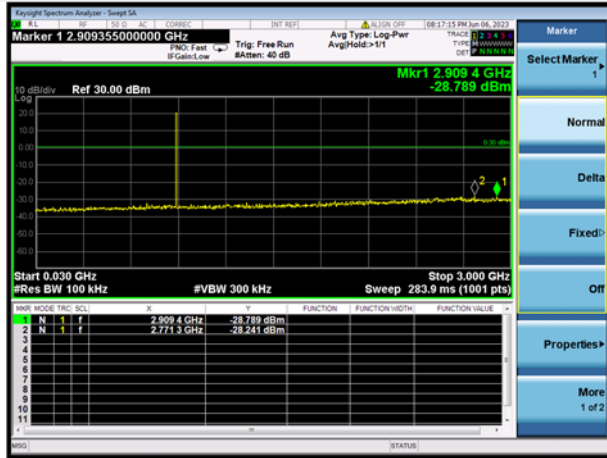

LoRa (500kHz) MIDDLE CHANNEL, SPURIOUS 2 GHz ~ 25 GHz

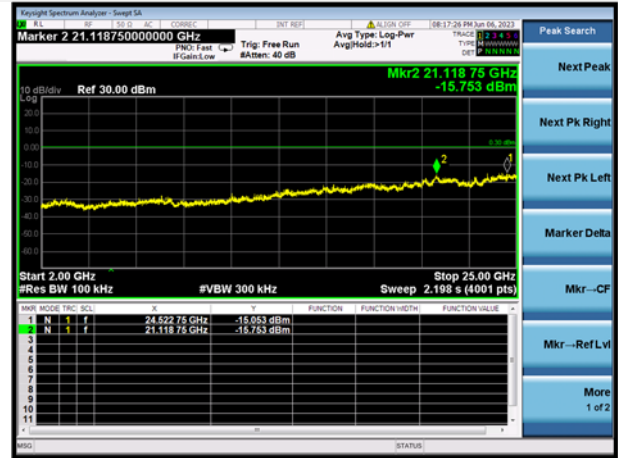

LoRa (500kHz) HIGH CHANNEL, CARRIER LEVEL



LoRa (500kHz) HIGH CHANNEL, SPURIOUS 30 MHz ~ 3 GHz

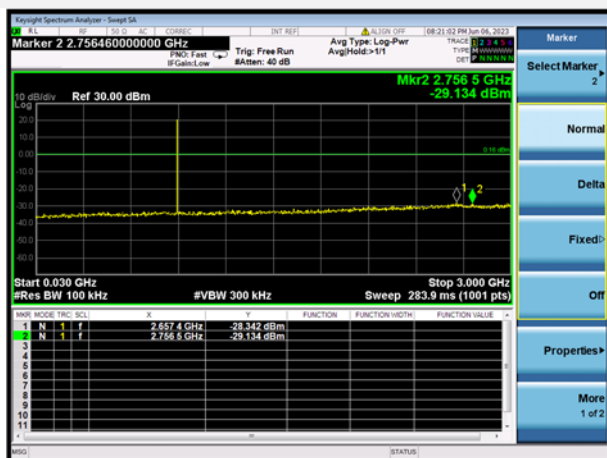

LoRa (500kHz) HIGH CHANNEL, SPURIOUS 2 GHz ~ 25 GHz

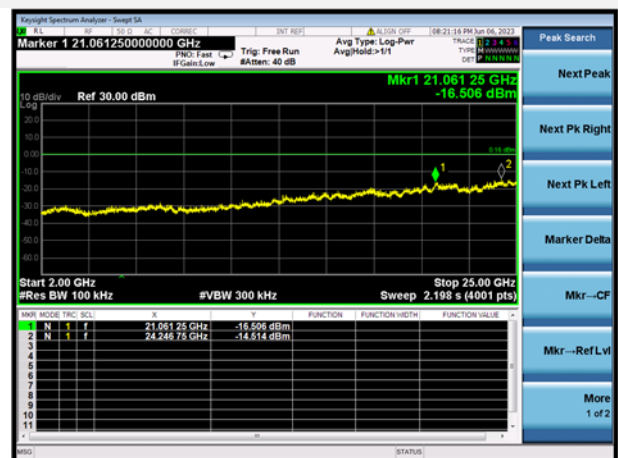

LoRa (1523kHz) LOW CHANNEL, CARRIER LEVEL

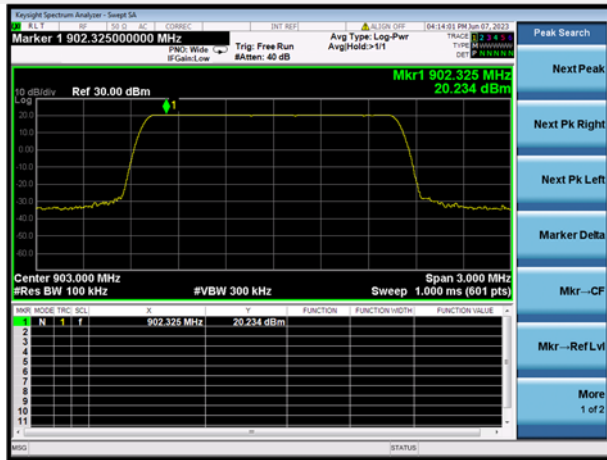

LoRa (1523kHz) LOW CHANNEL, SPURIOUS 30 MHz ~ 3 GHz

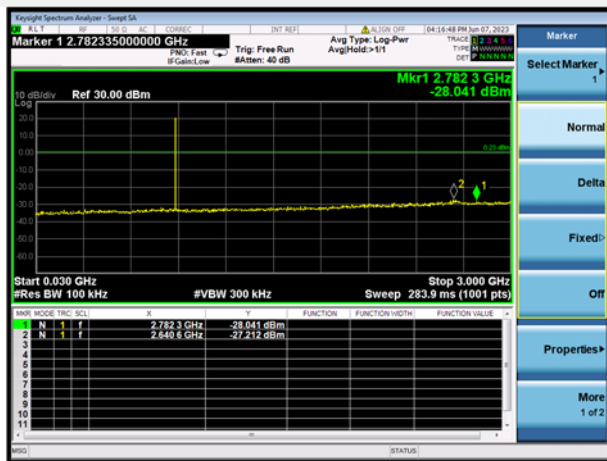

LoRa (1523kHz) LOW CHANNEL, SPURIOUS 2 GHz ~ 25 GHz



LoRa (1523kHz) MIDDLE CHANNEL, CARRIER LEVEL

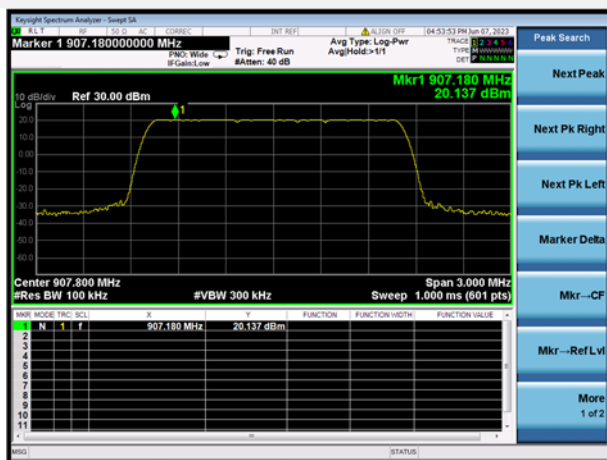

LoRa (1523kHz) MIDDLE CHANNEL, SPURIOUS  
30 MHz ~ 3 GHz

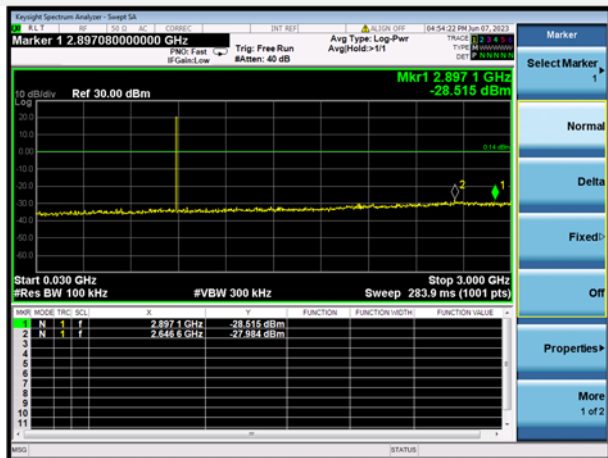

LoRa (1523kHz) MIDDLE CHANNEL, SPURIOUS  
2 GHz ~ 25 GHz

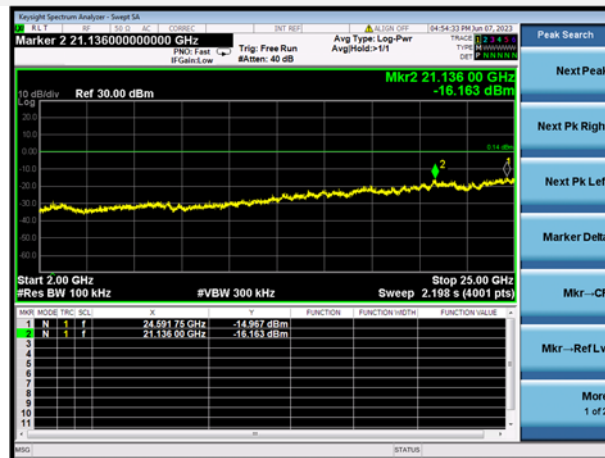

LoRa (1523kHz) HIGH CHANNEL,  
CARRIER LEVEL

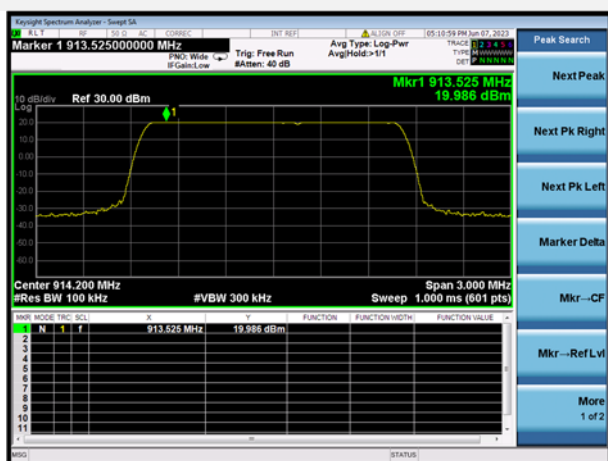

LoRa (1523kHz) HIGH CHANNEL,  
SPURIOUS 30 MHz ~ 3 GHz

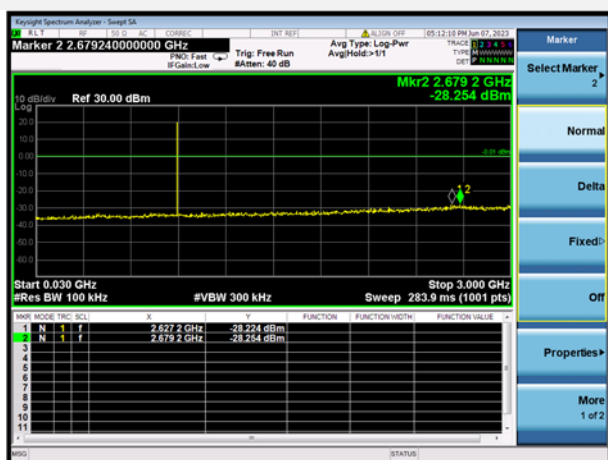

LoRa (1523kHz) HIGH CHANNEL,  
SPURIOUS 2 GHz ~ 25 GHz

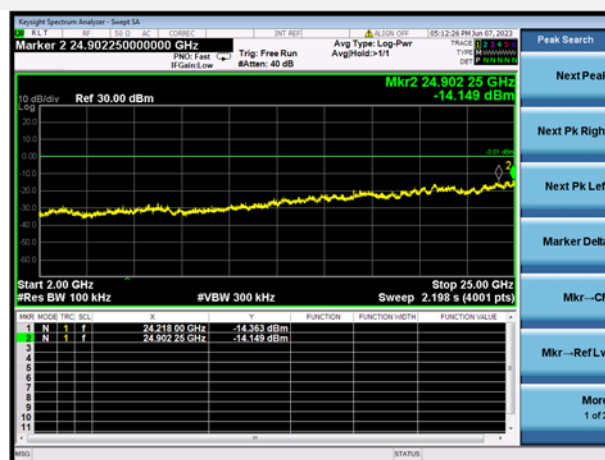

## A.4 Band Edge (Authorized-band band-edge)

Note: The lowest and highest channels are tested to verify the band edge emissions. Please refer to the following the plots for emissions values.

### Test Data

LoRa (500kHz)				
Channel	Measured Max. Band Edge Emission (dBm)	Limit (dBm)		Verdict
		Carrier Level	Calculated 20 dBc Limit	
Low Channel	-27.80	20.40	0.40	Pass
High Channel	-48.02	20.16	0.16	Pass

LoRa (1523kHz)				
Channel	Measured Max. Band Edge Emission (dBm)	Limit (dBm)		Verdict
		Carrier Level	Calculated 20 dBc Limit	
Low Channel	-27.57	20.23	0.23	Pass
High Channel	-49.38	19.99	-0.01	Pass

Test Plots

LoRa (500kHz) LOW CHANNEL, CARRIER LEVEL

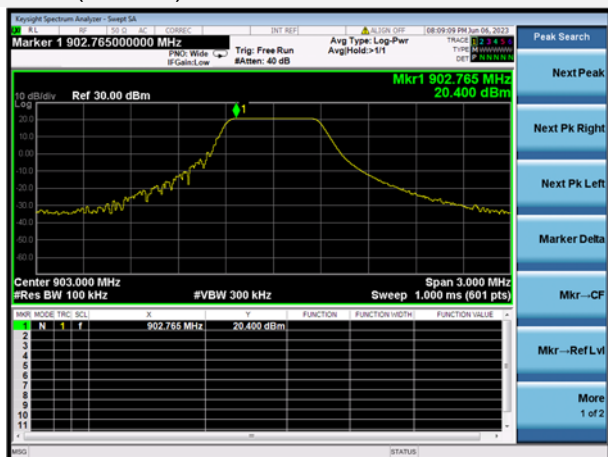

LoRa (500kHz) LOW CHANNEL, BAND EDGE

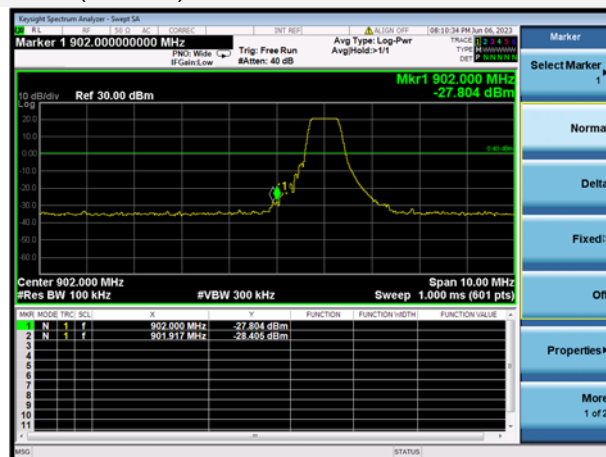

LoRa (500kHz) HIGH CHANNEL, CARRIER LEVEL

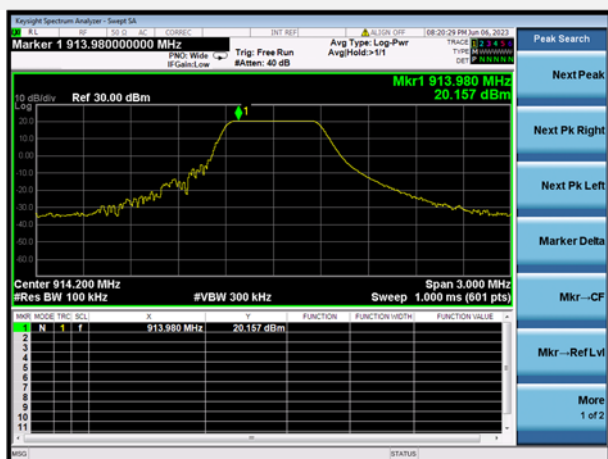

LoRa (500kHz) HIGH CHANNEL, BAND EDGE

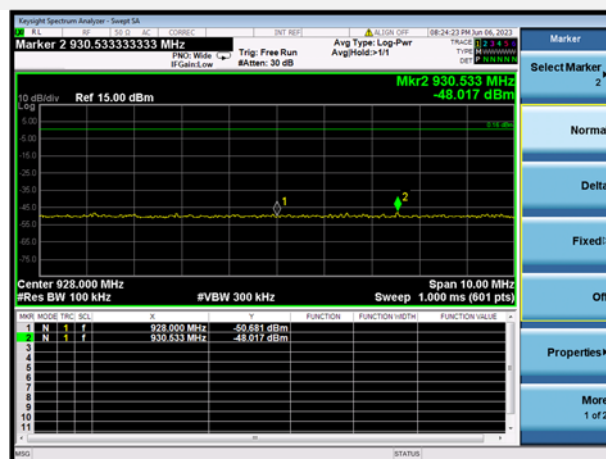

LoRa (1523kHz) LOW CHANNEL, CARRIER LEVEL

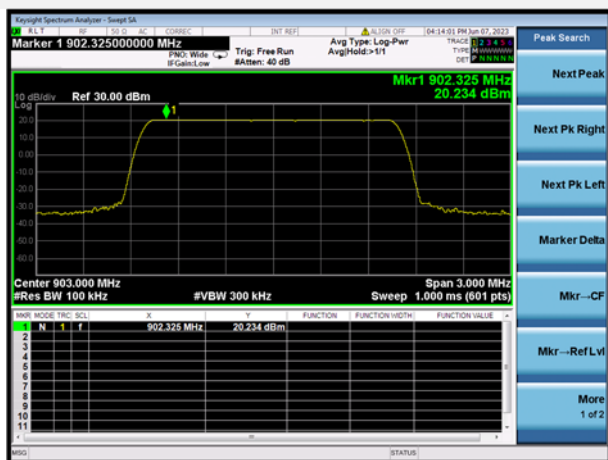

LoRa (1523kHz) LOW CHANNEL, BAND EDGE

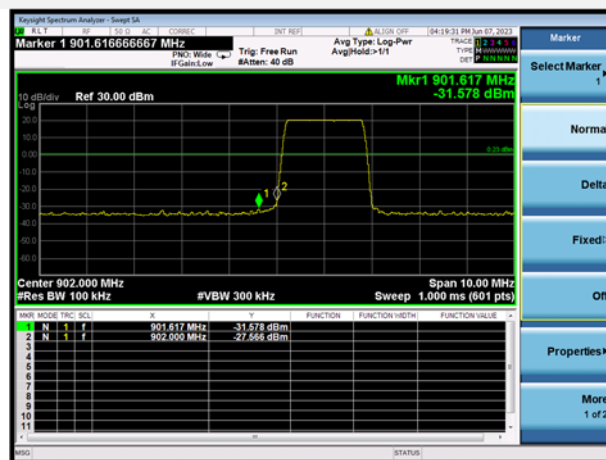



LoRa (1523kHz) HIGH CHANNEL, CARRIER LEVEL

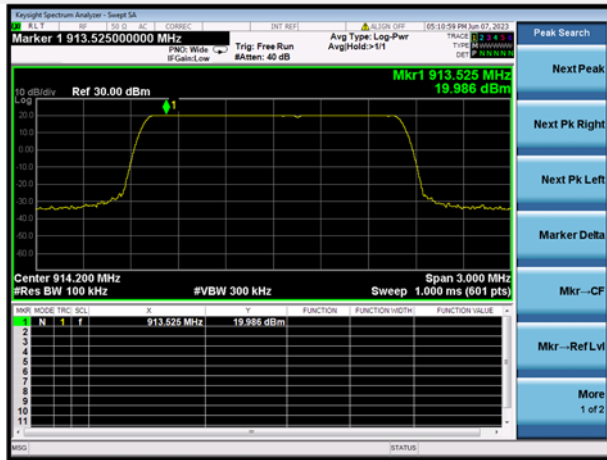

LoRa (1523kHz) HIGH CHANNEL, BAND EDGE

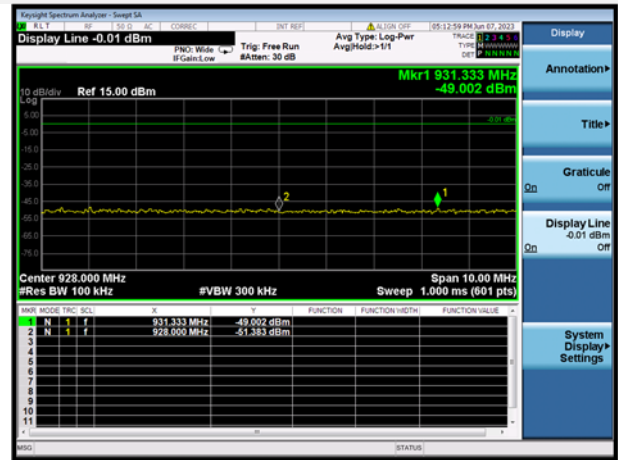

## A.5 Conducted Emissions

Note <sup>1</sup>: The EUT is working in the Normal link mode.

Note <sup>2</sup>: Results (dBuV) = Original reading level of Spectrum Analyzer (dBuV) + Factor (dB)

### Test Data and Plots

#### PHASE L

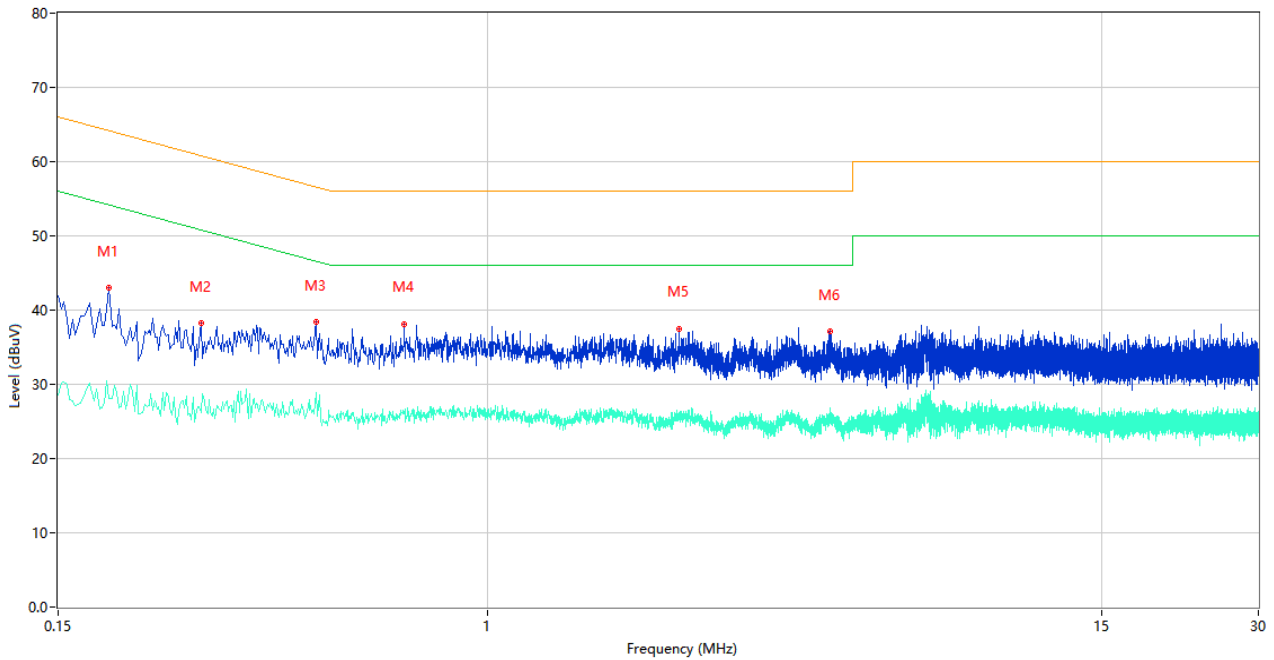

No.	Frequency (MHz)	Results (dBuV)	Factor (dB)	Limit (dBuV)	Margin (dB)	Detector	Line	Verdict
1	0.188	43.01	9.78	64.12	21.11	Peak	L	Pass
1**	0.188	28.04	9.78	54.12	26.08	AV	L	Pass
2	0.282	38.21	9.76	60.76	22.55	Peak	L	Pass
2**	0.282	26.26	9.76	50.76	24.50	AV	L	Pass
3	0.468	38.39	10.01	56.55	18.16	Peak	L	Pass
3**	0.468	28.94	10.01	46.55	17.61	AV	L	Pass
4	0.692	38.11	10.59	56.00	17.89	Peak	L	Pass
4**	0.692	26.14	10.59	46.00	19.86	AV	L	Pass
5	2.328	37.51	10.12	56.00	18.49	Peak	L	Pass
5**	2.328	26.24	10.12	46.00	19.76	AV	L	Pass
6	4.524	37.11	10.41	56.00	18.89	Peak	L	Pass
6**	4.524	26.80	10.41	46.00	19.20	AV	L	Pass

PHASE N

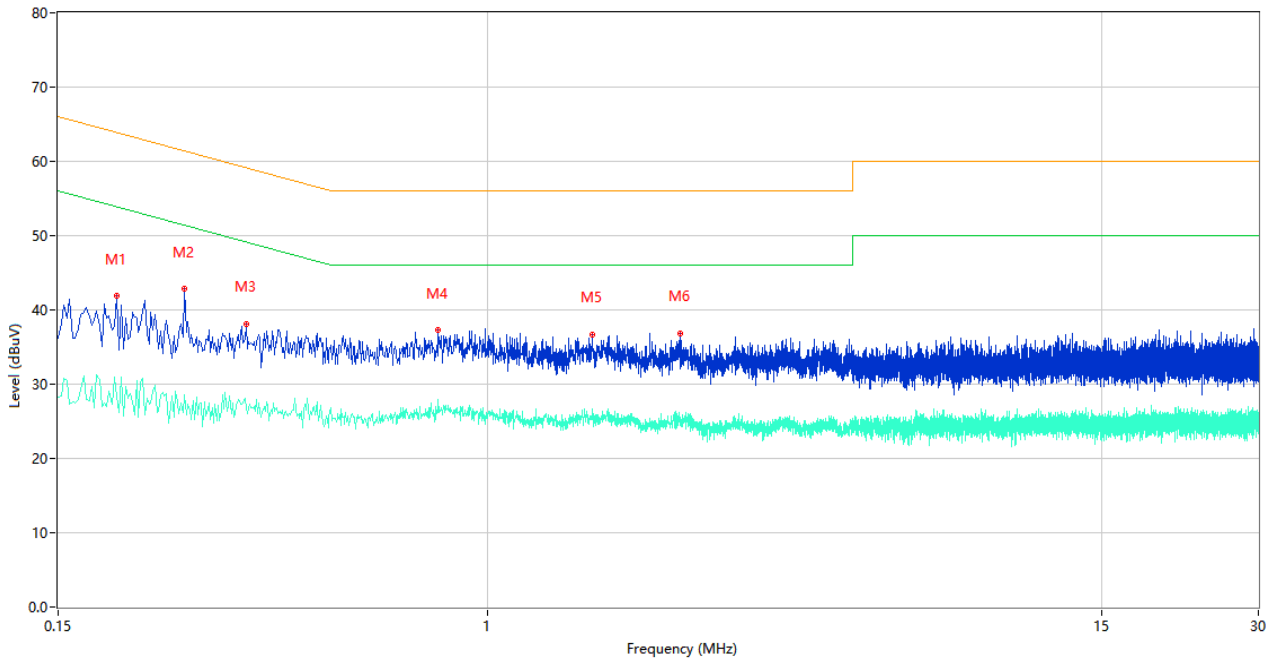

No.	Frequency (MHz)	Results (dBuV)	Factor (dB)	Limit (dBuV)	Margin (dB)	Detector	Line	Verdict
1	0.194	41.86	9.77	63.86	22.00	Peak	N	Pass
1**	0.194	28.40	9.77	53.86	25.46	AV	N	Pass
2	0.262	42.78	9.76	61.37	18.59	Peak	N	Pass
2**	0.262	28.56	9.76	51.37	22.81	AV	N	Pass
3	0.344	38.12	10.64	59.11	20.99	Peak	N	Pass
3**	0.344	26.83	10.64	49.11	22.28	AV	N	Pass
4	0.804	37.29	10.54	56.00	18.71	Peak	N	Pass
4**	0.804	27.91	10.54	46.00	18.09	AV	N	Pass
5	1.584	36.71	9.95	56.00	19.29	Peak	N	Pass
5**	1.584	26.69	9.95	46.00	19.31	AV	N	Pass
6	2.338	36.78	10.05	56.00	19.22	Peak	N	Pass
6**	2.338	25.48	10.05	46.00	20.52	AV	N	Pass

## A.6 Radiated Spurious Emission

Note <sup>1</sup>: The symbol of "--" in the table which means not application.

Note <sup>2</sup>: For the test data above 1 GHz, according to the ANSI C63.4-2014, where limits are specified for both average and peak (or quasi-peak) detector functions, if the peak (or quasi-peak) measured value complies with the average limit, it is unnecessary to perform an average measurement.

Note <sup>3</sup>: The low frequency, which started from 9 kHz to 30 MHz, was pre-scanned and the result which was 20 dB lower than the limit line per 15.31(o) was not reported.

Note <sup>4</sup>: The marked spikes near 900 MHz with circle should be ignored because they are Fundamental signal.

### Test Data and Plots

#### LoRa (500kHz) LOW CHANNEL, 30 MHz to 1 GHz, ANT H

RE Test case\_FCC Part 15C\_FCC 15.231(433MHz)\_30MHz-1GHz

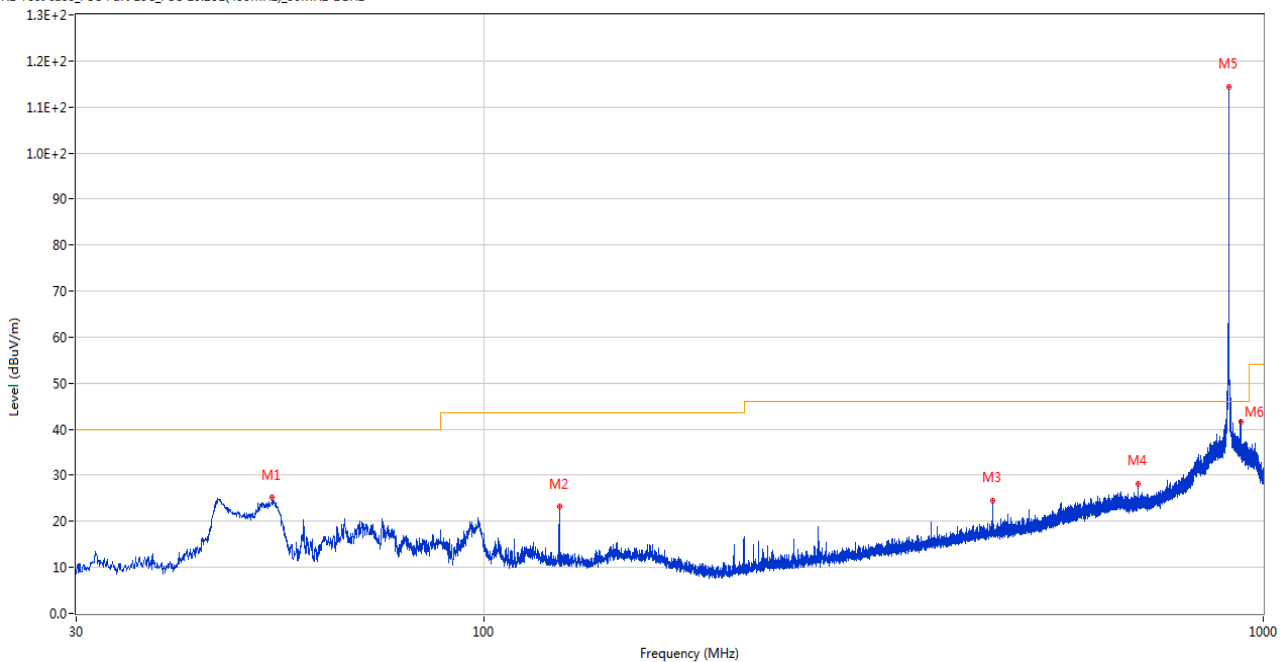

No.	Frequency (MHz)	Results (dBuV/m)	Factor (dB)	Limit (dBuV/m)	Margin (dB)	Detector	Table (Degree)	Height (cm)	Antenna	Verdict
1	53.571	25.18	-26.42	40.0	14.82	Peak	211.00	200	Horizontal	Pass
2	125.011	23.21	-26.17	43.5	20.29	Peak	33.00	150	Horizontal	Pass
3	450.058	24.56	-19.16	46.0	21.44	Peak	114.00	150	Horizontal	Pass
4	690.327	28.18	-13.18	46.0	17.82	Peak	13.00	300	Horizontal	Pass
5	903.194	114.36	-7.45	46.0	-68.36	Peak	19.00	300	Horizontal	N/A
6	935.156	41.67	-7.76	46.0	4.33	Peak	360.00	150	Horizontal	Pass

LoRa (500kHz) LOW CHANNEL, 30 MHz to 1 GHz, ANT V

RE Test case\_FCC Part 15C\_FCC 15.231(433MHz)\_30MHz-1GHz

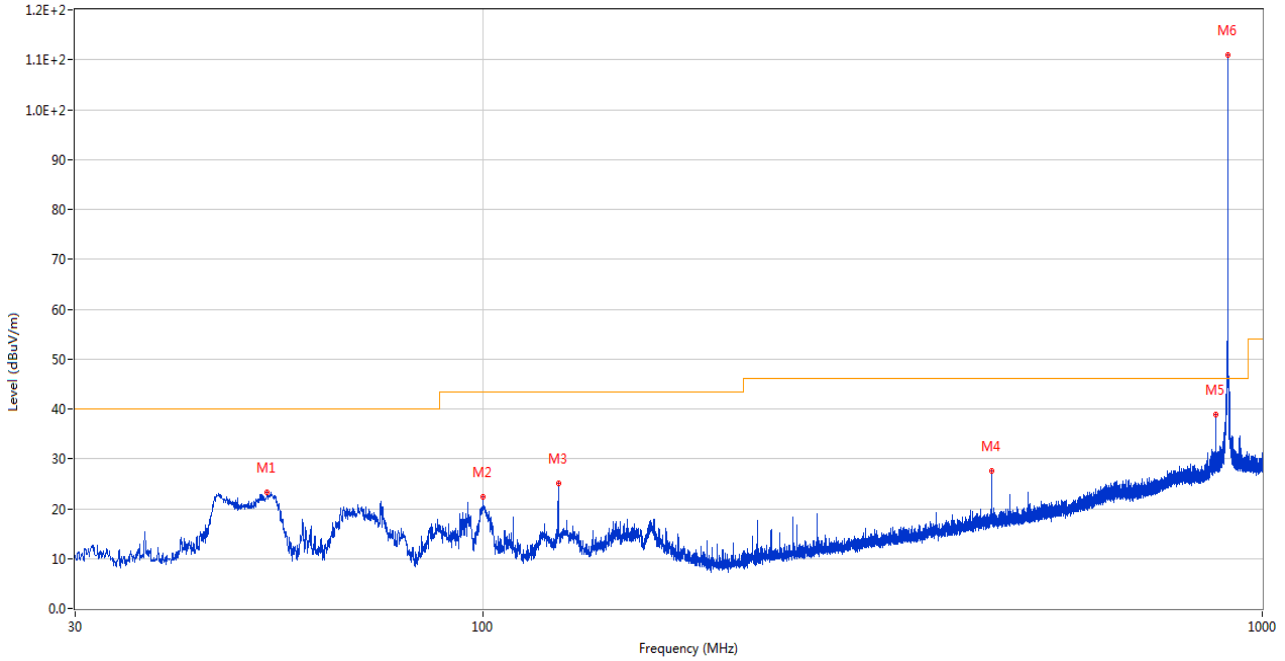

No.	Frequency (MHz)	Results (dBuV/m)	Factor (dB)	Limit (dBuV/m)	Margin (dB)	Detector	Table (Degree)	Height (cm)	Antenna	Verdict
1	52.941	23.32	-26.38	40.0	16.68	Peak	178.00	150	Vertical	Pass
2	99.985	22.31	-28.75	43.5	21.19	Peak	113.00	300	Vertical	Pass
3	125.011	25.00	-26.17	43.5	18.50	Peak	84.00	300	Vertical	Pass
4	450.058	27.59	-19.16	46.0	18.41	Peak	86.00	150	Vertical	Pass
5	870.990	38.87	-8.87	46.0	7.13	Peak	318.00	300	Vertical	Pass
6	903.194	110.89	-7.45	46.0	-64.89	Peak	108.00	300	Vertical	N/A

LoRa (500kHz) MIDDLE CHANNEL, 30 MHz to 1 GHz, ANT H

RE Test case\_FCC Part 15C\_FCC 15.231(433MHz)\_30MHz-1GHz

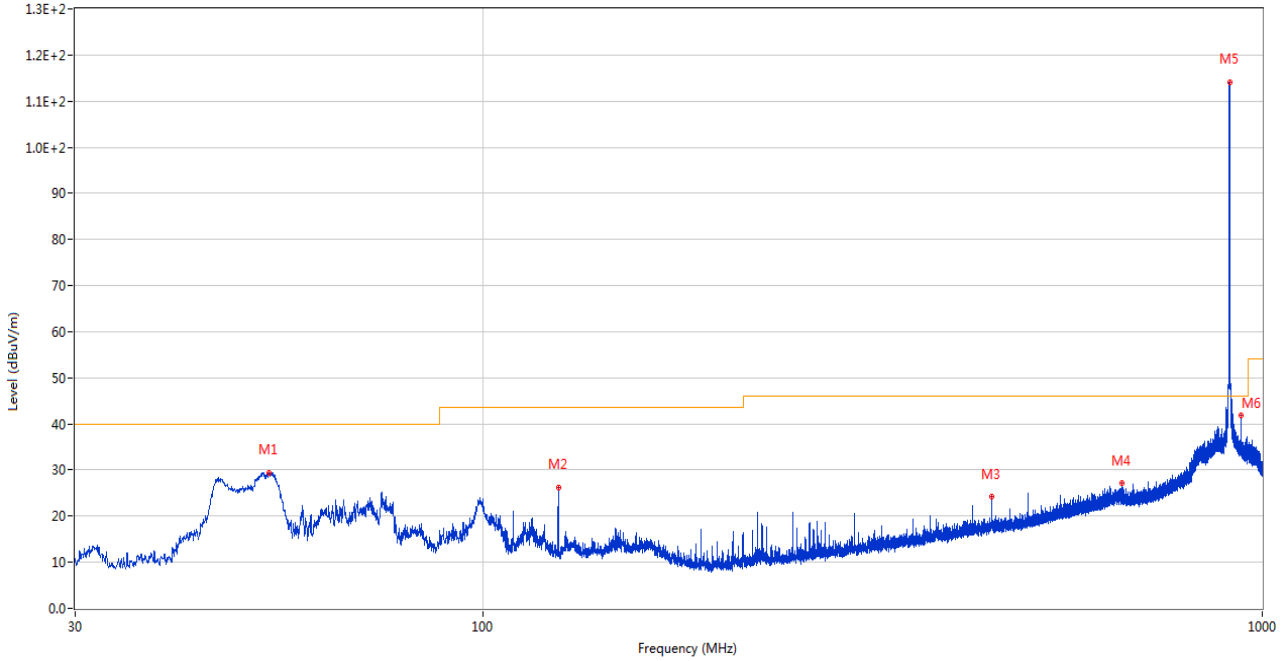

No.	Frequency (MHz)	Results (dBuV/m)	Factor (dB)	Limit (dBuV/m)	Margin (dB)	Detector	Table (Degree)	Height (cm)	Antenna	Verdict
1	53.183	29.49	-26.40	40.0	10.51	Peak	111.00	200	Horizontal	Pass
2	125.011	26.23	-26.17	43.5	17.27	Peak	93.00	150	Horizontal	Pass
3	450.058	24.23	-19.16	46.0	21.77	Peak	226.00	150	Horizontal	Pass
4	661.470	27.06	-13.32	46.0	18.94	Peak	192.00	300	Horizontal	Pass
5	907.656	114.15	-7.60	46.0	-68.15	Peak	0.00	150	Horizontal	N/A
6	939.714	41.87	-7.56	46.0	4.13	Peak	360.00	200	Horizontal	Pass

LoRa (500kHz) MIDDLE CHANNEL, 30 MHz to 1 GHz, ANT V

RE Test case\_FCC Part 15C\_FCC 15.231(433MHz)\_30MHz-1GHz

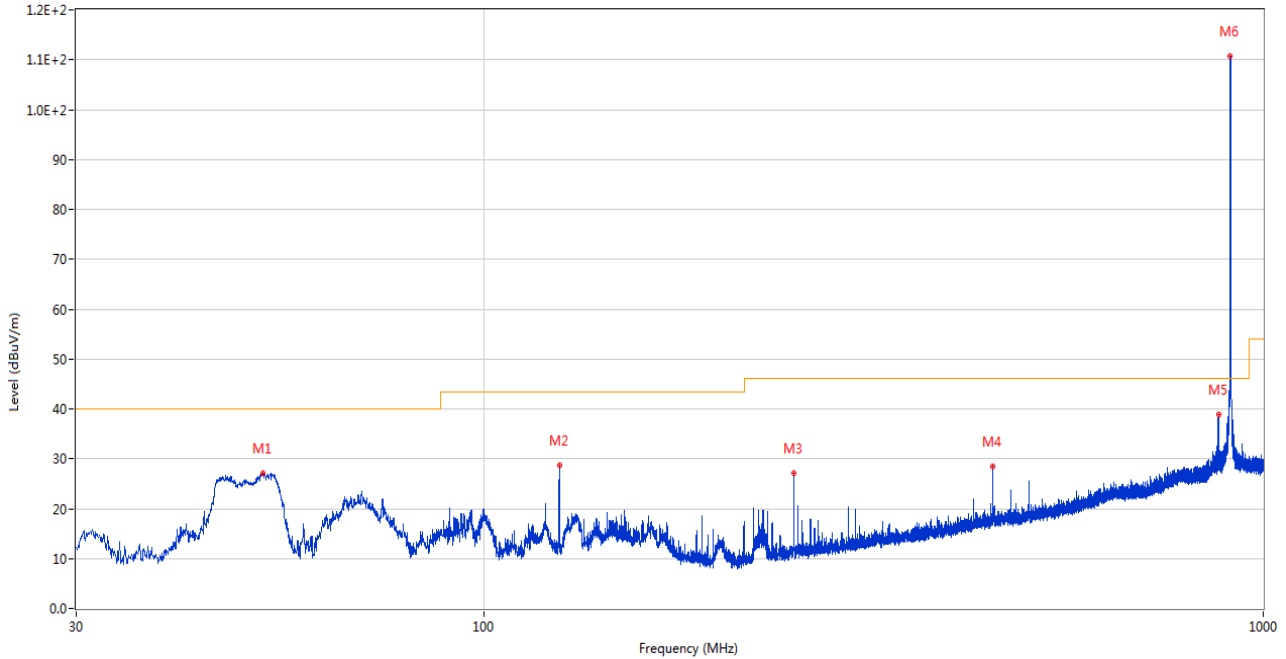

No.	Frequency (MHz)	Results (dBuV/m)	Factor (dB)	Limit (dBuV/m)	Margin (dB)	Detector	Table (Degree)	Height (cm)	Antenna	Verdict
1	52.019	27.12	-26.31	40.0	12.88	Peak	140.00	150	Vertical	Pass
2	125.011	28.67	-26.17	43.5	14.83	Peak	33.00	300	Vertical	Pass
3	250.044	27.18	-25.71	46.0	18.82	Peak	279.00	300	Vertical	Pass
4	450.058	28.36	-19.16	46.0	17.64	Peak	203.00	150	Vertical	Pass
5	875.937	38.78	-8.73	46.0	7.22	Peak	276.00	300	Vertical	Pass
6	907.607	110.65	-7.60	46.0	-64.65	Peak	106.00	300	Vertical	N/A

LoRa (500kHz) HIGH CHANNEL, 30 MHz to 1 GHz, ANT H

RE Test case\_FCC Part 15C\_FCC 15.231(433MHz)\_30MHz-1GHz

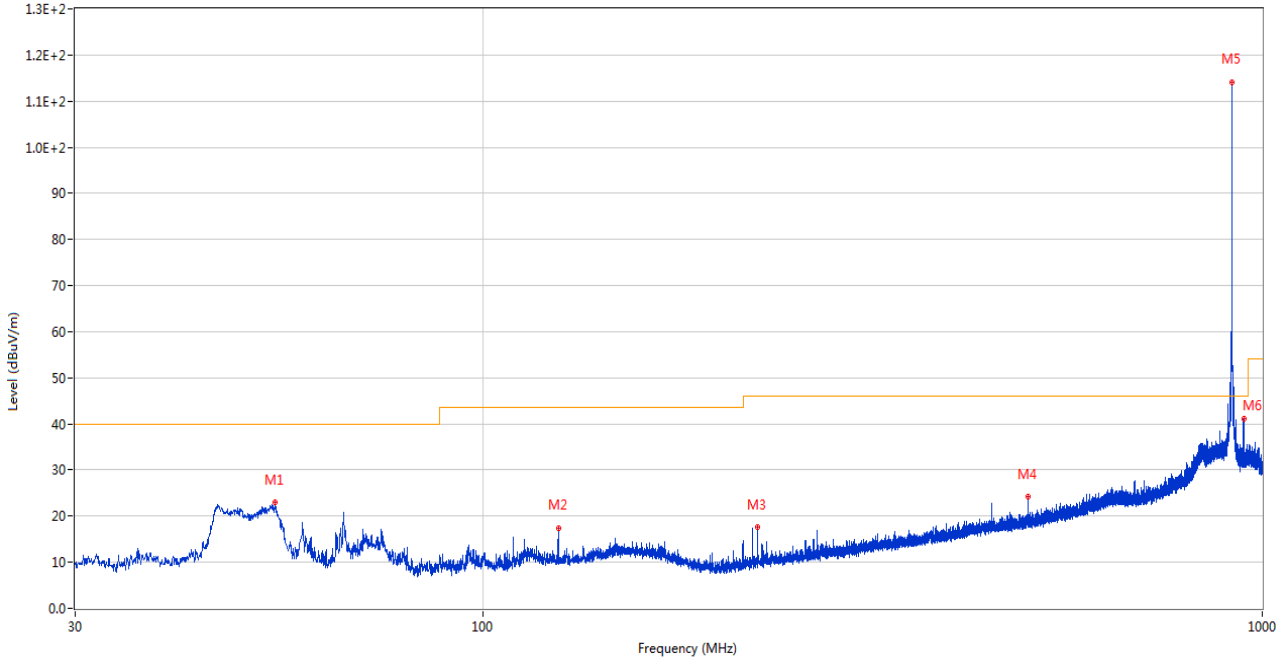

No.	Frequency (MHz)	Results (dBuV/m)	Factor (dB)	Limit (dBuV/m)	Margin (dB)	Detector	Table (Degree)	Height (cm)	Antenna	Verdict
1	54.202	22.94	-26.44	40.0	17.06	Peak	0.00	200	Horizontal	Pass
2	125.011	17.50	-26.17	43.5	26.00	Peak	26.00	150	Horizontal	Pass
3	225.067	17.65	-26.59	46.0	28.35	Peak	218.00	150	Horizontal	Pass
4	500.062	24.16	-18.36	46.0	21.84	Peak	40.00	200	Horizontal	Pass
5	914.155	114.13	-7.81	46.0	-68.13	Peak	360.00	150	Horizontal	N/A
6	946.456	41.15	-7.78	46.0	4.85	Peak	5.00	150	Horizontal	Pass



LoRa (500kHz) HIGH CHANNEL, 30 MHz to 1 GHz, ANT V

RE Test case\_FCC Part 15C\_FCC 15.231(433MHz)\_30MHz-1GHz

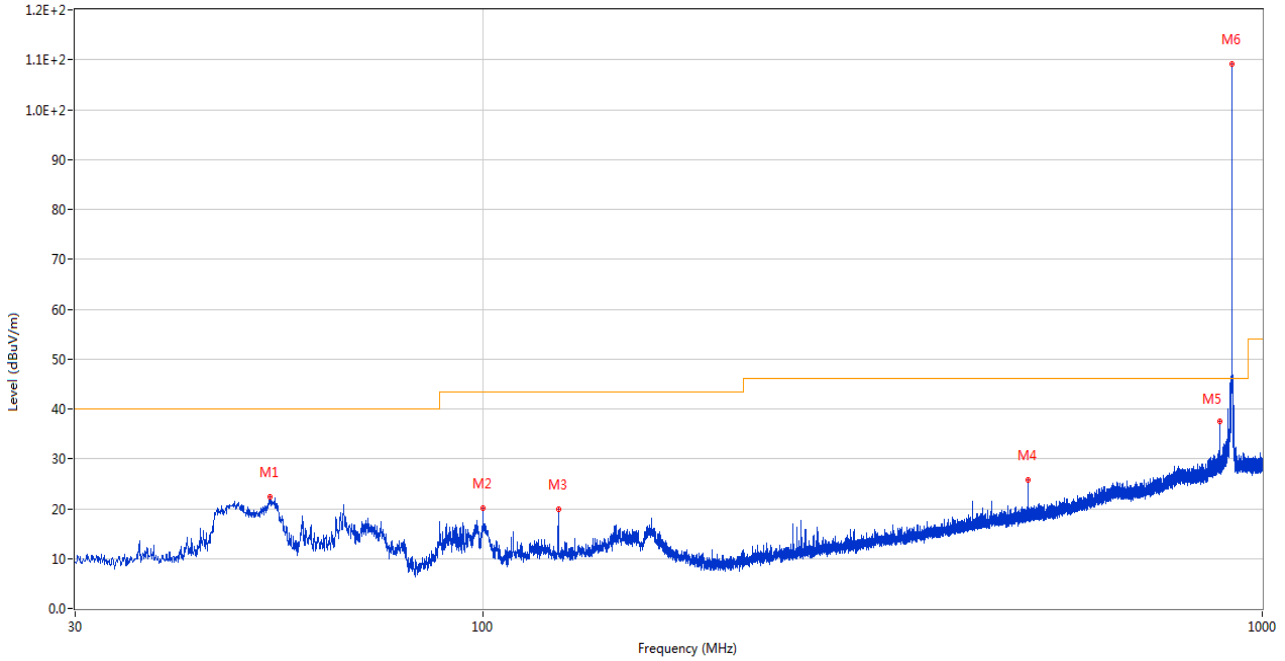

No.	Frequency (MHz)	Results (dBuV/m)	Factor (dB)	Limit (dBuV/m)	Margin (dB)	Detector	Table (Degree)	Height (cm)	Antenna	Verdict
1	53.280	22.41	-26.40	40.0	17.59	Peak	312.00	150	Vertical	Pass
2	100.034	20.15	-28.74	43.5	23.35	Peak	148.00	300	Vertical	Pass
3	125.011	19.81	-26.17	43.5	23.69	Peak	24.00	200	Vertical	Pass
4	500.062	25.67	-18.36	46.0	20.33	Peak	126.00	200	Vertical	Pass
5	881.999	37.62	-8.67	46.0	8.38	Peak	277.00	300	Vertical	Pass
6	914.252	109.15	-7.81	46.0	-63.15	Peak	106.00	300	Vertical	N/A

LoRa (500kHz) LOW CHANNEL 1 GHz to 10 GHz, ANT H

RE Test case\_FCC Part 15C\_FCC 15.249\_1GHz-10GHz

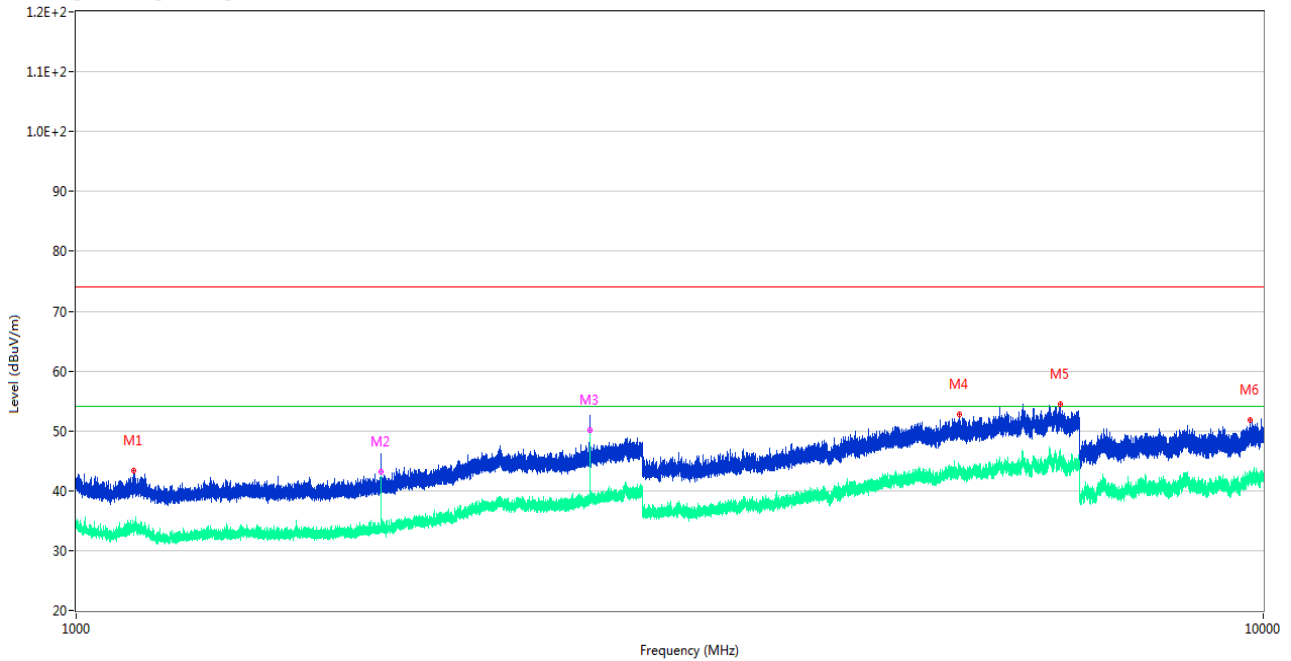

No.	Frequency (MHz)	Results (dBuV/m)	Factor (dB)	Limit (dBuV/m)	Margin (dB)	Detector	Table (Degree)	Height (cm)	Antenna	Verdict
1	1117.800	43.35	-14.47	74.0	30.65	Peak	336.00	200	Horizontal	Pass
1**	1117.800	34.19	-14.47	54.0	19.81	AV	336.00	200	Horizontal	Pass
2	1806.000	45.56	-13.09	74.0	28.44	Peak	68.00	150	Horizontal	Pass
2**	1806.000	43.17	-13.09	54.0	10.83	AV	68.00	150	Horizontal	Pass
3	2709.200	51.96	-7.03	74.0	22.04	Peak	33.00	150	Horizontal	Pass
3**	2709.200	50.18	-7.03	54.0	3.82	AV	33.00	150	Horizontal	Pass
4	5545.600	52.84	-1.56	74.0	21.16	Peak	57.00	100	Horizontal	Pass
4**	5545.600	43.68	-1.56	54.0	10.32	AV	57.00	100	Horizontal	Pass
5	6753.000	54.48	-0.18	74.0	19.52	Peak	192.00	150	Horizontal	Pass
5**	6753.000	44.33	-0.18	54.0	9.67	AV	192.00	150	Horizontal	Pass
6	9750.850	51.86	-0.42	74.0	22.14	Peak	360.00	200	Horizontal	Pass
6**	9750.850	41.98	-0.42	54.0	12.02	AV	360.00	200	Horizontal	Pass

LoRa (500kHz) LOW CHANNEL 1 GHz to 10 GHz, ANT V

RE Test case\_FCC Part 15C\_FCC 15.249\_1GHz-10GHz

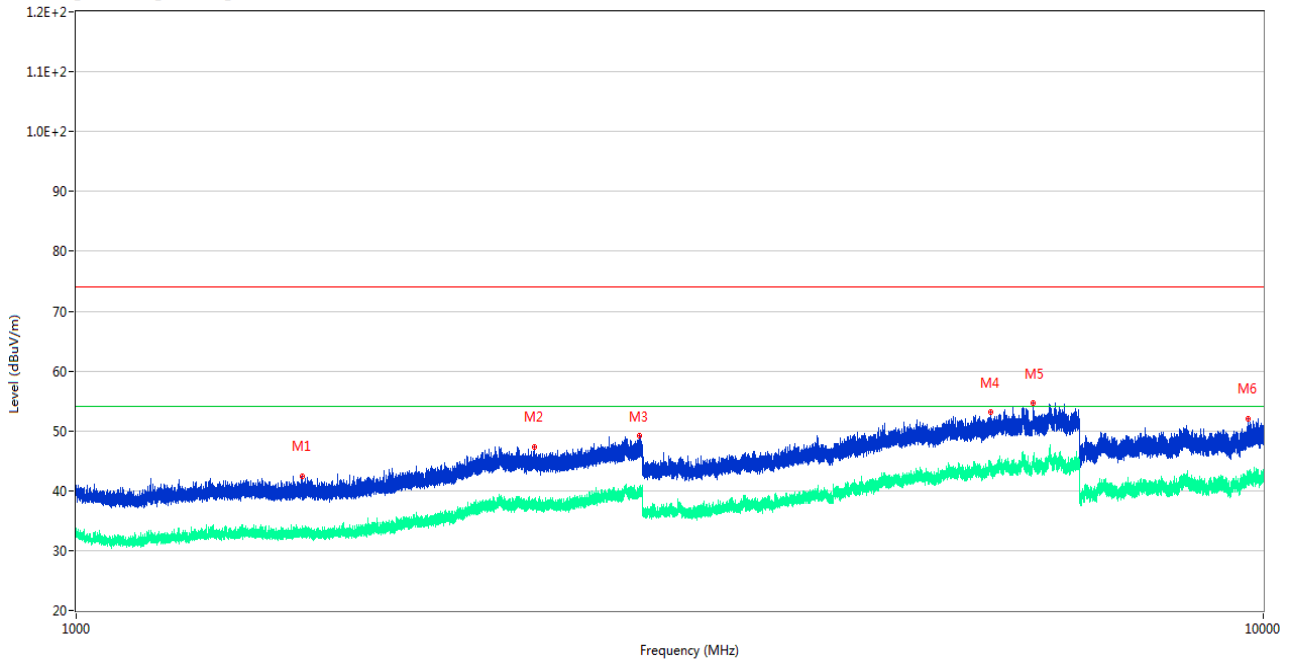

No.	Frequency (MHz)	Results (dBuV/m)	Factor (dB)	Limit (dBuV/m)	Margin (dB)	Detector	Table (Degree)	Height (cm)	Antenna	Verdict
1	1549.300	42.45	-13.67	74.0	31.55	Peak	0.00	400	Vertical	Pass
1**	1549.300	33.34	-13.67	54.0	20.66	AV	0.00	400	Vertical	Pass
2	2433.000	47.32	-8.21	74.0	26.68	Peak	152.00	400	Vertical	Pass
2**	2433.000	37.57	-8.21	54.0	16.43	AV	152.00	400	Vertical	Pass
3	2982.500	49.22	-4.57	74.0	24.78	Peak	86.00	200	Vertical	Pass
3**	2982.500	39.92	-4.57	54.0	14.08	AV	86.00	200	Vertical	Pass
4	5891.400	53.07	-0.99	74.0	20.93	Peak	187.00	400	Vertical	Pass
4**	5891.400	43.80	-0.99	54.0	10.20	AV	187.00	400	Vertical	Pass
5	6403.800	54.68	0.15	74.0	19.32	Peak	342.00	100	Vertical	Pass
5**	6403.800	45.33	0.15	54.0	8.67	AV	342.00	100	Vertical	Pass
6	9701.650	52.09	-0.07	74.0	21.91	Peak	16.00	300	Vertical	Pass
6**	9701.650	41.48	-0.07	54.0	12.52	AV	16.00	300	Vertical	Pass

LoRa (500kHz) MIDDLE CHANNEL 1 GHz to 10 GHz, ANT H

RE Test case\_FCC Part 15C\_FCC 15.249\_1GHz-10GHz

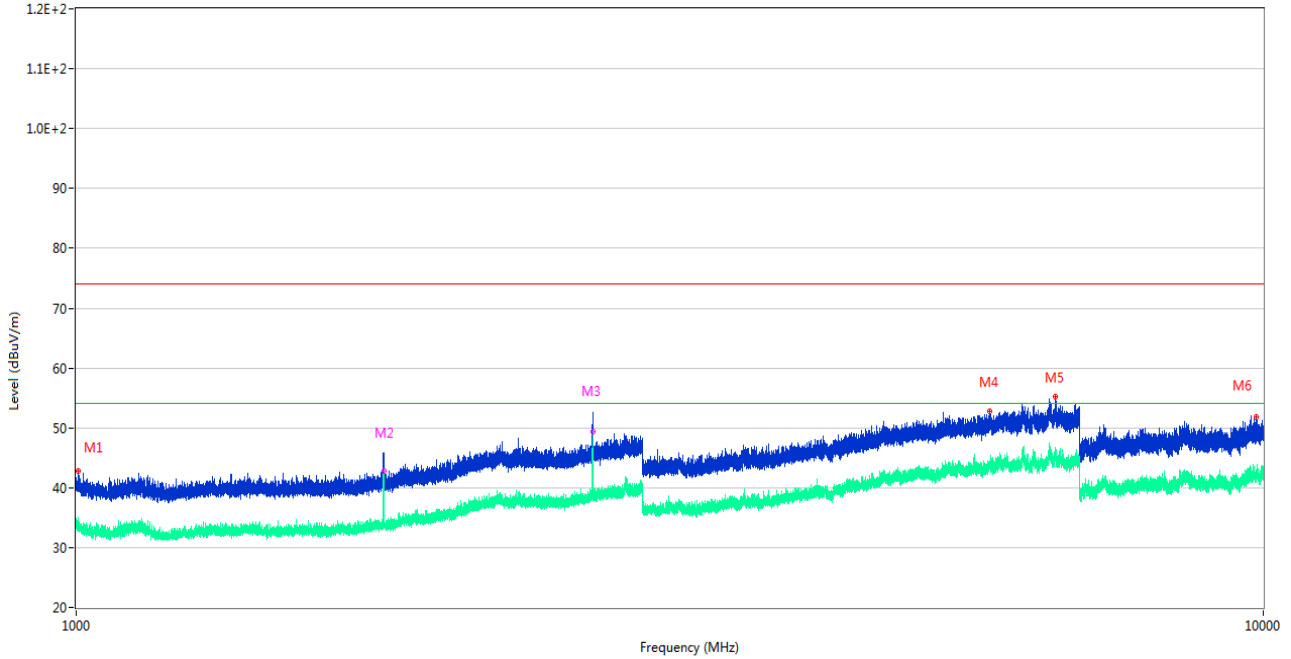

No.	Frequency (MHz)	Results (dBuV/m)	Factor (dB)	Limit (dBuV/m)	Margin (dB)	Detector	Table (Degree)	Height (cm)	Antenna	Verdict
1	1003.500	42.70	-12.57	74.0	31.30	Peak	312.00	100	Horizontal	Pass
1**	1003.500	33.70	-12.57	54.0	20.30	AV	312.00	100	Horizontal	Pass
2	1815.700	45.38	-13.08	74.0	28.62	Peak	84.00	150	Horizontal	Pass
2**	1815.700	42.75	-13.08	54.0	11.25	AV	84.00	150	Horizontal	Pass
3	2723.600	51.35	-6.52	74.0	22.65	Peak	31.00	150	Horizontal	Pass
3**	2723.600	49.36	-6.52	54.0	4.64	AV	31.00	150	Horizontal	Pass
4	5887.400	52.68	-0.92	74.0	21.32	Peak	301.00	400	Horizontal	Pass
4**	5887.400	43.97	-0.92	54.0	10.03	AV	301.00	400	Horizontal	Pass
5	6676.000	55.19	0.29	74.0	18.81	Peak	343.00	100	Horizontal	Pass
5**	6676.000	45.39	0.29	54.0	8.61	AV	343.00	100	Horizontal	Pass
6	9872.500	51.75	-0.82	74.0	22.25	Peak	133.00	300	Horizontal	Pass
6**	9872.500	41.80	-0.82	54.0	12.20	AV	133.00	300	Horizontal	Pass

LoRa (500kHz) MIDDLE CHANNEL 1 GHz to 10 GHz, ANT V

RE Test case\_FCC Part 15C\_FCC 15.249\_1GHz-10GHz

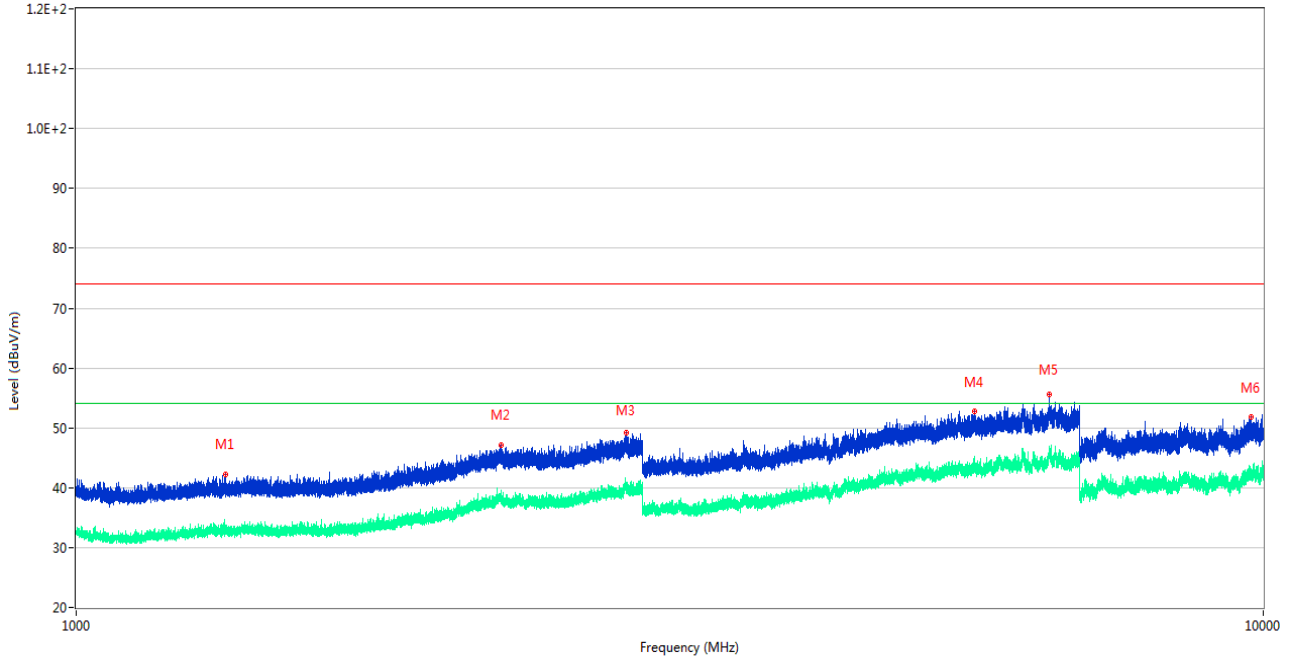

No.	Frequency (MHz)	Results (dBuV/m)	Factor (dB)	Limit (dBuV/m)	Margin (dB)	Detector	Table (Degree)	Height (cm)	Antenna	Verdict
1	1335.000	42.27	-13.11	74.0	31.73	Peak	292.00	100	Vertical	Pass
1**	1335.000	32.71	-13.11	54.0	21.29	AV	292.00	100	Vertical	Pass
2	2280.200	47.14	-8.04	74.0	26.86	Peak	155.00	300	Vertical	Pass
2**	2280.200	37.88	-8.04	54.0	16.12	AV	155.00	300	Vertical	Pass
3	2904.800	49.16	-3.44	74.0	24.84	Peak	102.00	150	Vertical	Pass
3**	2904.800	40.61	-3.44	54.0	13.39	AV	102.00	150	Vertical	Pass
4	5708.400	52.76	-1.55	74.0	21.24	Peak	113.00	200	Vertical	Pass
4**	5708.400	43.73	-1.55	54.0	10.27	AV	113.00	200	Vertical	Pass
5	6607.600	55.62	1.52	74.0	18.38	Peak	29.00	100	Vertical	Pass
5**	6607.600	46.43	1.52	54.0	7.57	AV	29.00	100	Vertical	Pass
6	9769.450	51.81	-0.33	74.0	22.19	Peak	349.00	200	Vertical	Pass
6**	9769.450	42.33	-0.33	54.0	11.67	AV	349.00	200	Vertical	Pass

LoRa (500kHz) HIGH CHANNEL 1 GHz to 10 GHz, ANT H

RE Test case\_FCC Part 15C\_FCC 15.249\_1GHz-10GHz

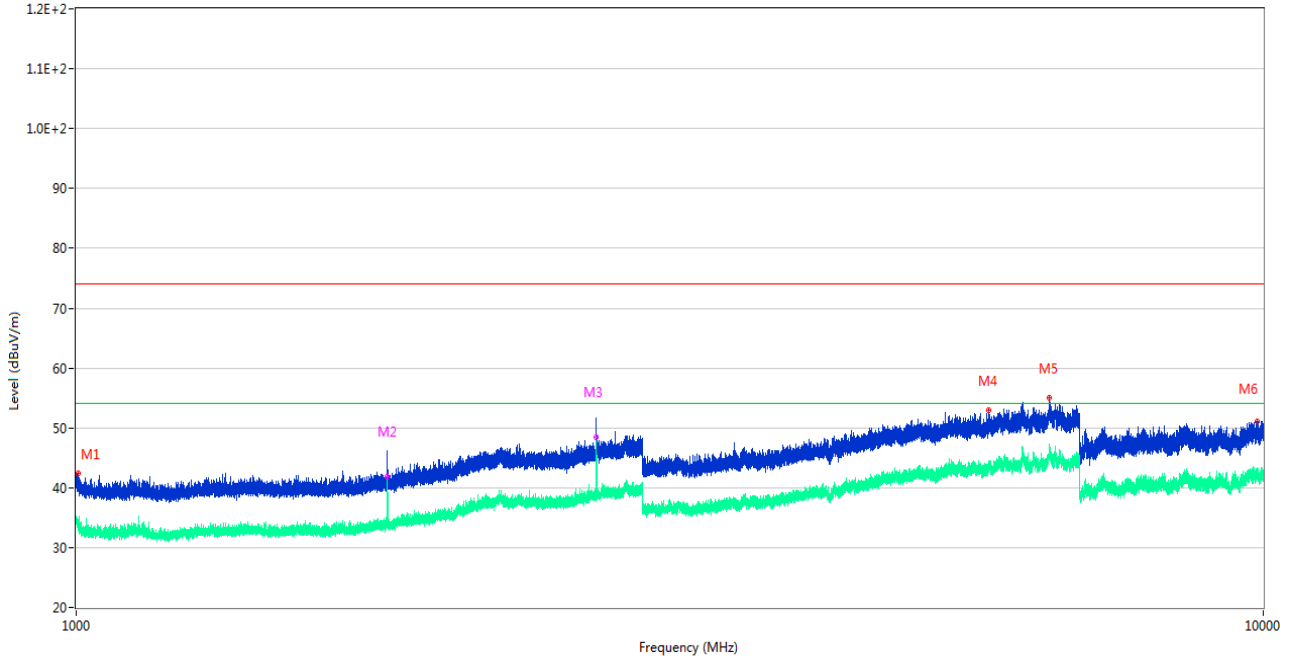

No.	Frequency (MHz)	Results (dBuV/m)	Factor (dB)	Limit (dBuV/m)	Margin (dB)	Detector	Table (Degree)	Height (cm)	Antenna	Verdict
1	1004.900	42.47	-12.81	74.0	31.53	Peak	316.00	300	Horizontal	Pass
1**	1004.900	33.90	-12.81	54.0	20.10	AV	316.00	300	Horizontal	Pass
2	1828.900	45.11	-12.62	74.0	28.89	Peak	65.00	150	Horizontal	Pass
2**	1828.900	41.87	-12.62	54.0	12.13	AV	65.00	150	Horizontal	Pass
3	2742.500	50.84	-7.04	74.0	23.16	Peak	124.00	150	Horizontal	Pass
3**	2742.500	48.40	-7.04	54.0	5.60	AV	124.00	150	Horizontal	Pass
4	5872.000	52.91	-1.39	74.0	21.09	Peak	223.00	300	Horizontal	Pass
4**	5872.000	42.82	-1.39	54.0	11.18	AV	223.00	300	Horizontal	Pass
5	6608.600	54.96	1.59	74.0	19.04	Peak	6.00	100	Horizontal	Pass
5**	6608.600	46.28	1.59	54.0	7.72	AV	6.00	100	Horizontal	Pass
6	9874.300	51.09	-0.84	74.0	22.91	Peak	76.00	100	Horizontal	Pass
6**	9874.300	42.63	-0.84	54.0	11.37	AV	76.00	100	Horizontal	Pass

LoRa (500kHz) HIGH CHANNEL 1 GHz to 10 GHz, ANT V

RE Test case\_FCC Part 15C\_FCC 15.249\_1GHz-10GHz

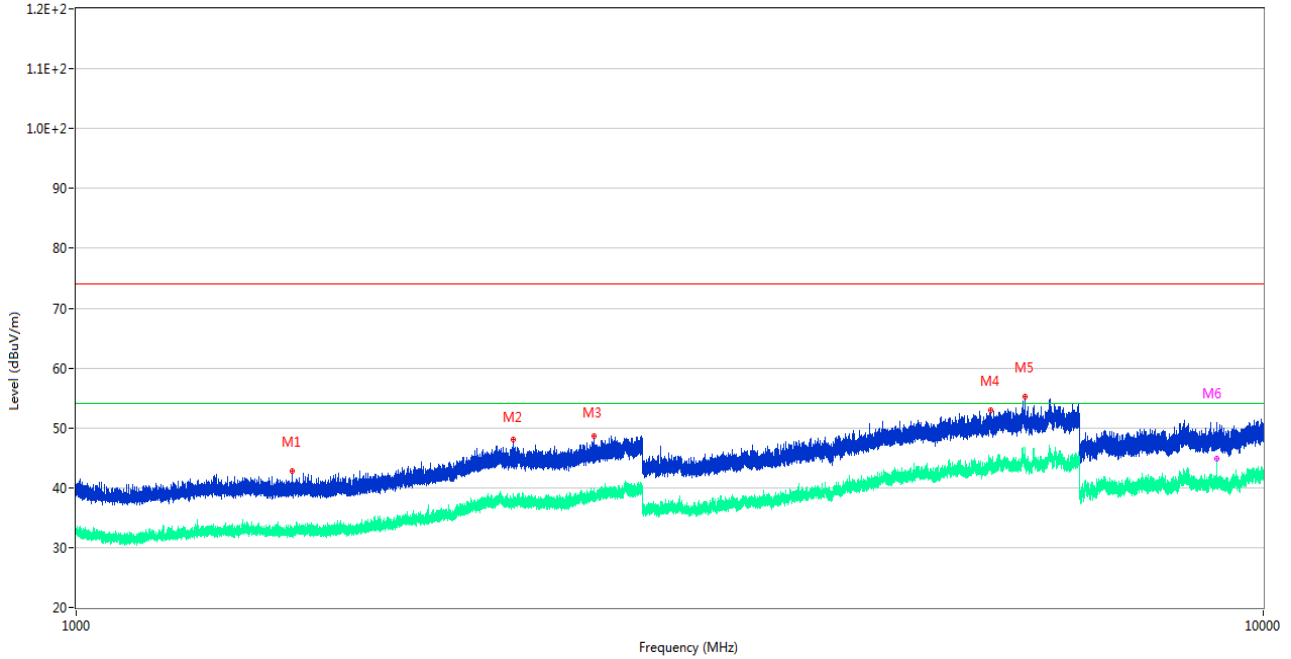

No.	Frequency (MHz)	Results (dBuV/m)	Factor (dB)	Limit (dBuV/m)	Margin (dB)	Detector	Table (Degree)	Height (cm)	Antenna	Verdict
1	1521.700	42.71	-13.78	74.0	31.29	Peak	197.00	300	Vertical	Pass
1**	1521.700	32.68	-13.78	54.0	21.32	AV	197.00	300	Vertical	Pass
2	2334.800	48.07	-8.71	74.0	25.93	Peak	360.00	100	Vertical	Pass
2**	2334.800	38.04	-8.71	54.0	15.96	AV	360.00	100	Vertical	Pass
3	2728.700	48.69	-6.56	74.0	25.31	Peak	244.00	150	Vertical	Pass
3**	2728.700	39.05	-6.56	54.0	14.95	AV	244.00	150	Vertical	Pass
4	5889.200	52.93	-0.90	74.0	21.07	Peak	58.00	300	Vertical	Pass
4**	5889.200	44.53	-0.90	54.0	9.47	AV	58.00	300	Vertical	Pass
5	6296.200	55.13	0.28	74.0	18.87	Peak	211.00	200	Vertical	Pass
5**	6296.200	44.76	0.28	54.0	9.24	AV	211.00	200	Vertical	Pass
6	9143.500	48.34	-1.45	74.0	25.66	Peak	283.00	150	Vertical	Pass
6**	9143.500	44.84	-1.45	54.0	9.16	AV	283.00	150	Vertical	Pass

LoRa (1523kHz) LOW CHANNEL, 30 MHz to 1 GHz, ANT H

RE Test case\_FCC Part 15C\_FCC 15.231(433MHz)\_30MHz-1GHz

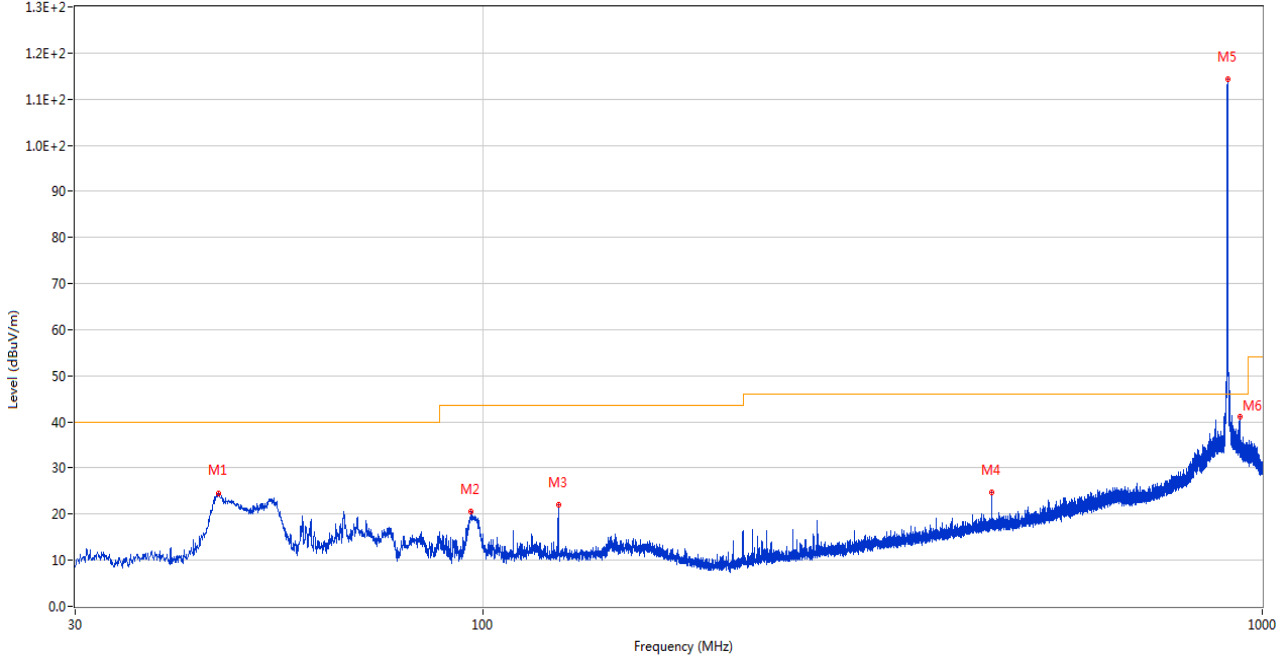

No.	Frequency (MHz)	Results (dBuV/m)	Factor (dB)	Limit (dBuV/m)	Margin (dB)	Detector	Table (Degree)	Height (cm)	Antenna	Verdict
1	45.763	24.60	-26.19	40.0	15.40	Peak	2.00	200	Horizontal	Pass
2	96.493	20.46	-29.08	43.5	23.04	Peak	315.00	200	Horizontal	Pass
3	125.011	21.98	-26.17	43.5	21.52	Peak	360.00	150	Horizontal	Pass
4	450.058	24.70	-19.16	46.0	21.30	Peak	112.00	150	Horizontal	Pass
5	902.903	114.29	-7.50	46.0	-68.29	Peak	4.00	300	Horizontal	N/A
6	935.689	41.19	-7.74	46.0	4.81	Peak	359.00	150	Horizontal	Pass



LoRa (1523kHz) LOW CHANNEL, 30 MHz to 1 GHz, ANT V

RE Test case\_FCC Part 15C\_FCC 15.231(433MHz)\_30MHz-1GHz

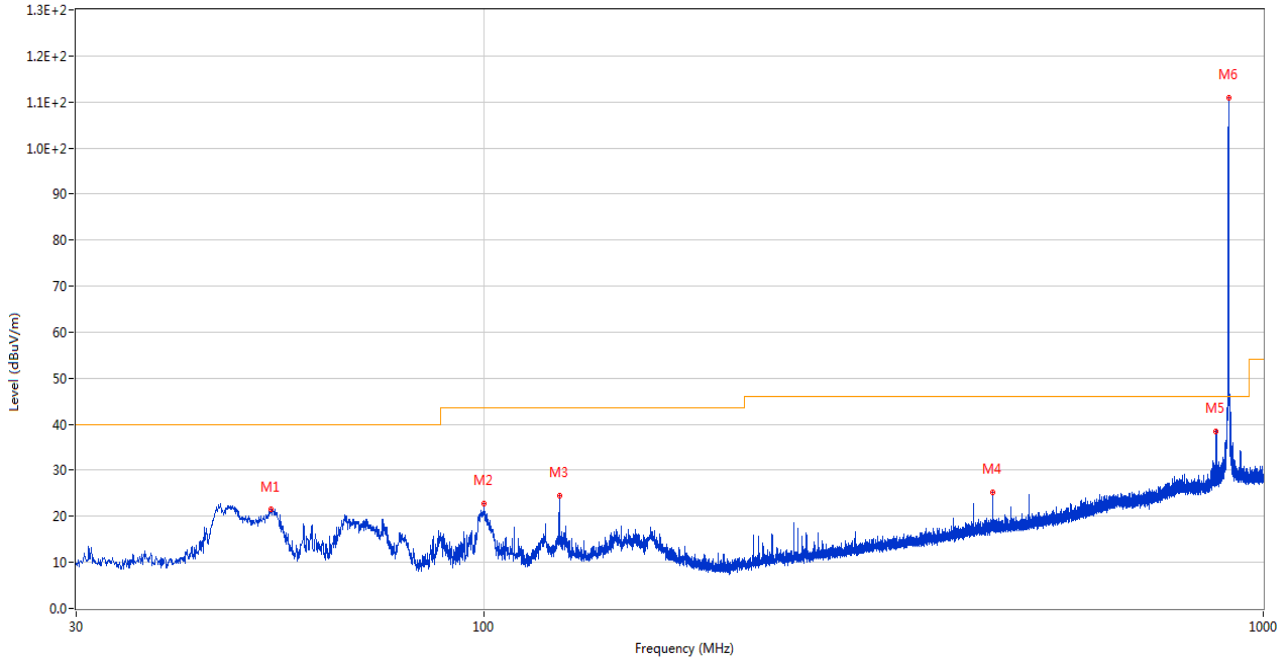

No.	Frequency (MHz)	Results (dBuV/m)	Factor (dB)	Limit (dBuV/m)	Margin (dB)	Detector	Table (Degree)	Height (cm)	Antenna	Verdict
1	53.377	21.47	-26.41	40.0	18.53	Peak	295.00	150	Vertical	Pass
2	100.034	22.87	-28.74	43.5	20.63	Peak	277.00	300	Vertical	Pass
3	125.011	24.57	-26.17	43.5	18.93	Peak	345.00	200	Vertical	Pass
4	450.058	25.33	-19.16	46.0	20.67	Peak	97.00	150	Vertical	Pass
5	870.505	38.33	-8.97	46.0	7.67	Peak	277.00	300	Vertical	Pass
6	902.854	110.95	-7.51	46.0	-64.95	Peak	109.00	300	Vertical	N/A

LoRa (1523kHz) MIDDLE CHANNEL, 30 MHz to 1 GHz, ANT H

RE Test case\_FCC Part 15C\_FCC 15.231(433MHz)\_30MHz-1GHz

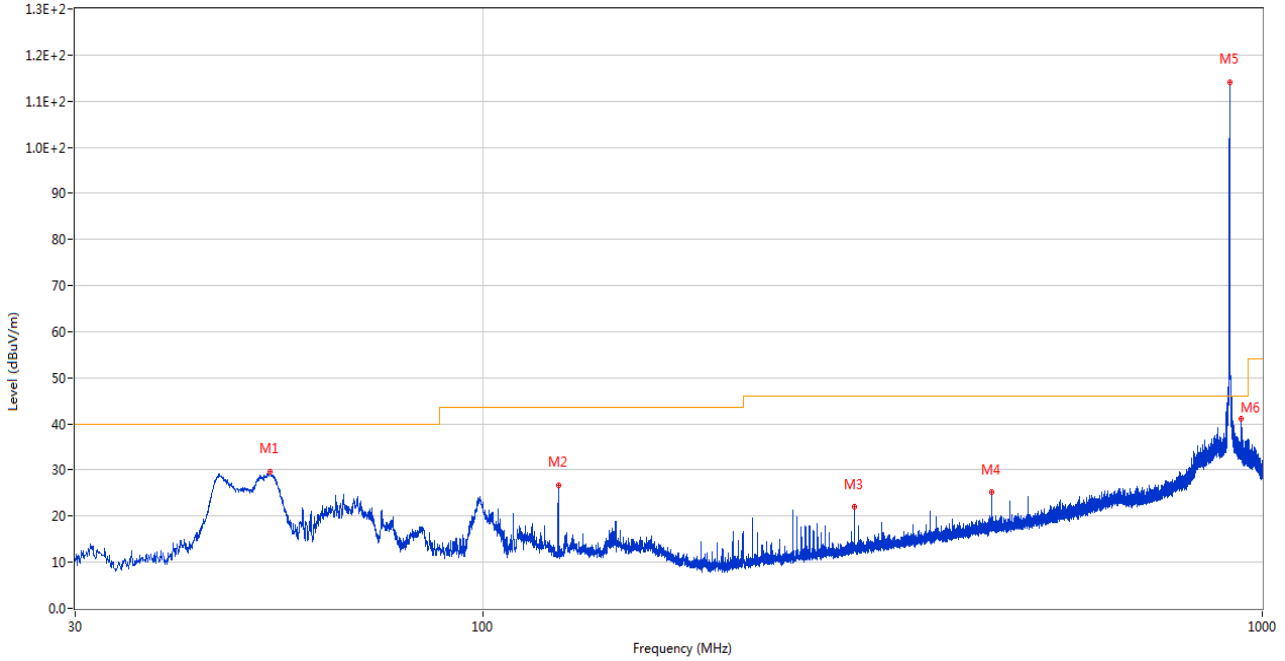

No.	Frequency (MHz)	Results (dBuV/m)	Factor (dB)	Limit (dBuV/m)	Margin (dB)	Detector	Table (Degree)	Height (cm)	Antenna	Verdict
1	53.328	29.72	-26.41	40.0	10.28	Peak	184.00	200	Horizontal	Pass
2	125.011	26.72	-26.17	43.5	16.78	Peak	260.00	150	Horizontal	Pass
3	300.048	22.04	-24.07	46.0	23.96	Peak	178.00	200	Horizontal	Pass
4	450.058	25.18	-19.16	46.0	20.82	Peak	354.00	300	Horizontal	Pass
5	909.063	114.19	-7.61	46.0	-68.19	Peak	22.00	150	Horizontal	N/A
6	940.151	41.14	-7.58	46.0	4.86	Peak	24.00	150	Horizontal	Pass

LoRa (1523kHz) MIDDLE CHANNEL, 30 MHz to 1 GHz, ANT V

RE Test case\_FCC Part 15C\_FCC 15.231(433MHz)\_30MHz-1GHz

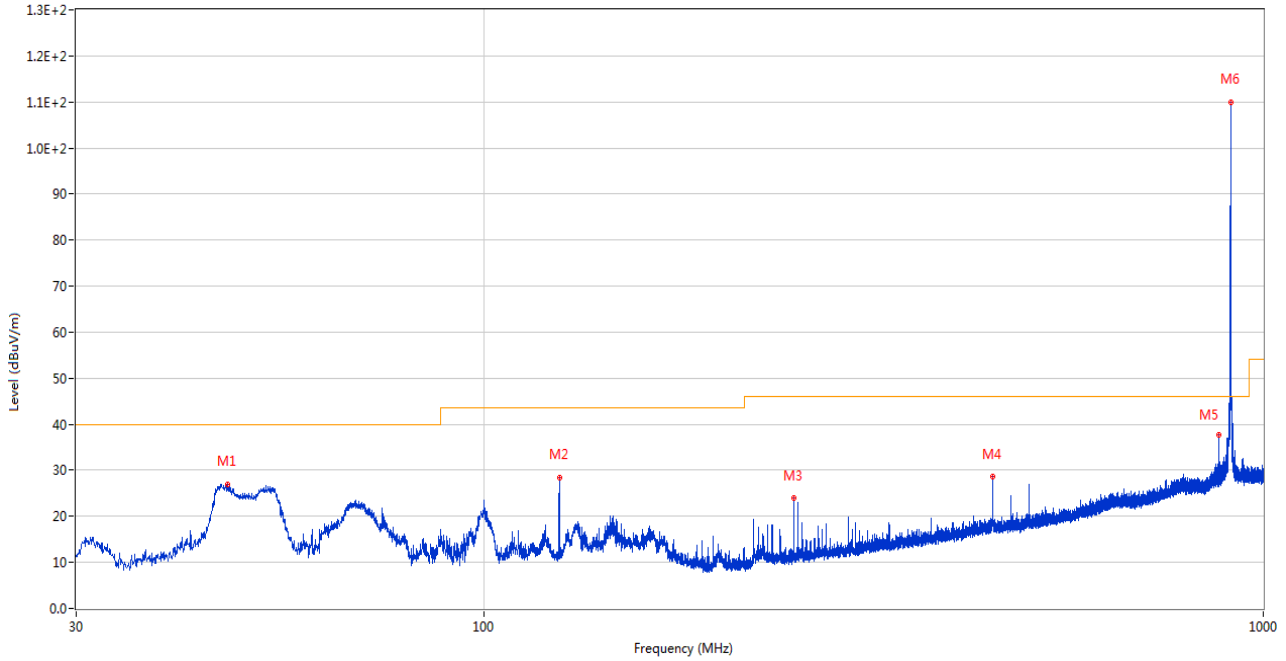

No.	Frequency (MHz)	Results (dBuV/m)	Factor (dB)	Limit (dBuV/m)	Margin (dB)	Detector	Table (Degree)	Height (cm)	Antenna	Verdict
1	46.975	27.05	-26.17	40.0	12.95	Peak	292.00	150	Vertical	Pass
2	125.011	28.45	-26.17	43.5	15.05	Peak	51.00	300	Vertical	Pass
3	250.044	23.95	-25.71	46.0	22.05	Peak	222.00	300	Vertical	Pass
4	450.058	28.57	-19.16	46.0	17.43	Peak	263.00	150	Vertical	Pass
5	876.034	37.62	-8.72	46.0	8.38	Peak	271.00	300	Vertical	Pass
6	907.995	109.95	-7.60	46.0	-63.95	Peak	271.00	300	Vertical	N/A

LoRa (1523kHz) HIGH CHANNEL, 30 MHz to 1 GHz, ANT H

RE Test case\_FCC Part 15C\_FCC 15.231(433MHz)\_30MHz-1GHz

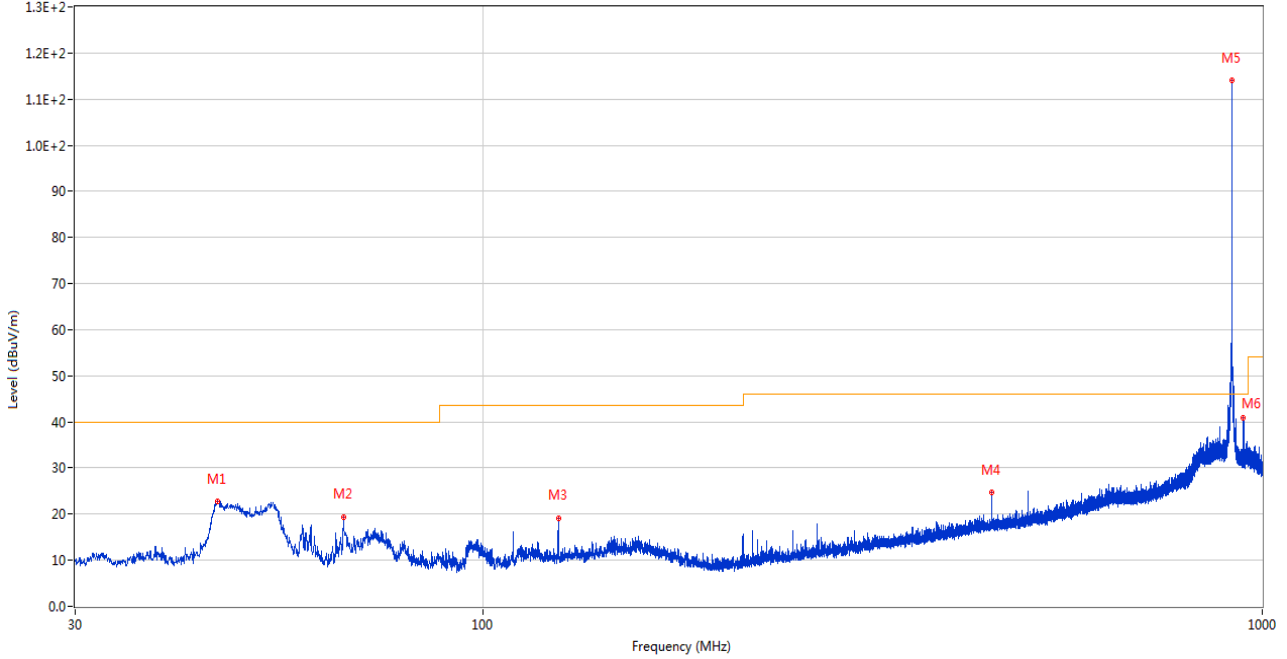

No.	Frequency (MHz)	Results (dBuV/m)	Factor (dB)	Limit (dBuV/m)	Margin (dB)	Detector	Table (Degree)	Height (cm)	Antenna	Verdict
1	45.666	22.77	-26.19	40.0	17.23	Peak	74.00	200	Horizontal	Pass
2	66.326	19.38	-27.91	40.0	20.62	Peak	320.00	200	Horizontal	Pass
3	125.011	19.12	-26.17	43.5	24.38	Peak	0.00	150	Horizontal	Pass
4	450.107	24.69	-19.16	46.0	21.31	Peak	206.00	150	Horizontal	Pass
5	914.446	114.10	-7.82	46.0	-68.10	Peak	360.00	150	Horizontal	N/A
6	945.486	40.83	-7.75	46.0	5.17	Peak	10.00	150	Horizontal	Pass

LoRa (1523kHz) HIGH CHANNEL, 30 MHz to 1 GHz, ANT V

RE Test case\_FCC Part 15C\_FCC 15.231(433MHz)\_30MHz-1GHz

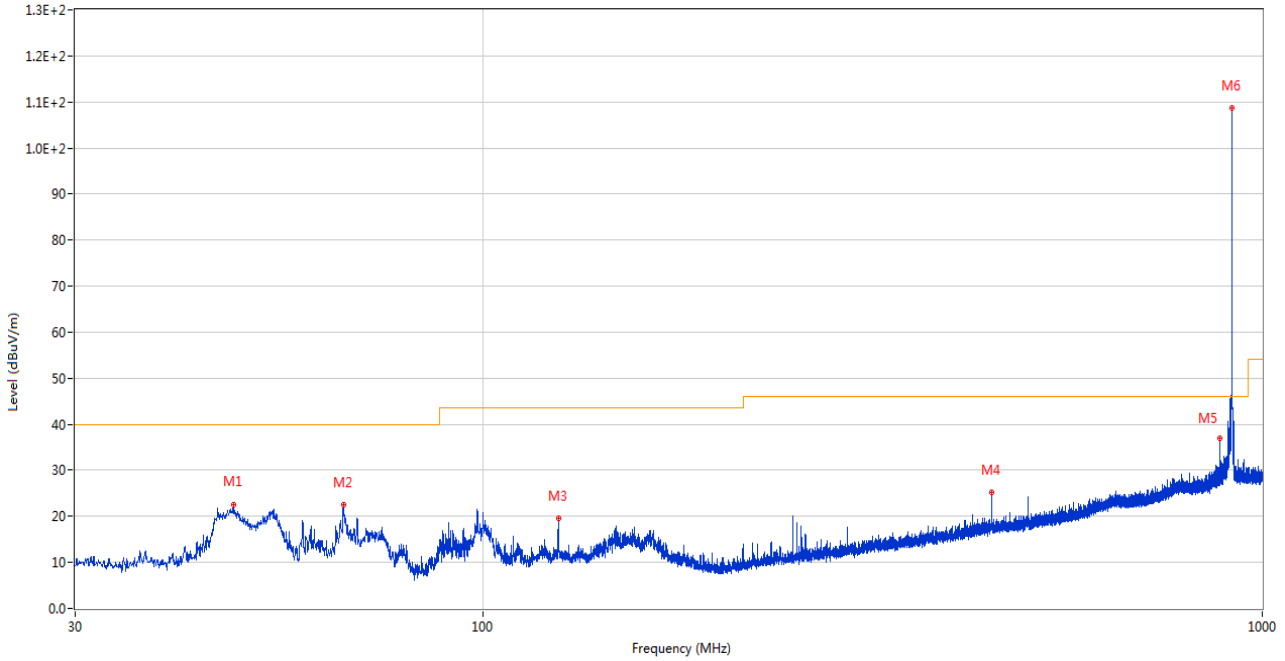

No.	Frequency (MHz)	Results (dBuV/m)	Factor (dB)	Limit (dBuV/m)	Margin (dB)	Detector	Table (Degree)	Height (cm)	Antenna	Verdict
1	47.848	22.59	-26.14	40.0	17.41	Peak	184.00	150	Vertical	Pass
2	66.230	22.44	-27.90	40.0	17.56	Peak	333.00	200	Vertical	Pass
3	125.011	19.59	-26.17	43.5	23.91	Peak	116.00	200	Vertical	Pass
4	450.058	25.17	-19.16	46.0	20.83	Peak	328.00	150	Vertical	Pass
5	881.514	37.07	-8.71	46.0	8.93	Peak	309.00	300	Vertical	Pass
6	914.204	108.61	-7.81	46.0	-62.61	Peak	108.00	300	Vertical	N/A

LoRa (1523kHz) LOW CHANNEL 1 GHz to 10 GHz, ANT H

RE Test case\_FCC Part 15C\_FCC 15.249\_1GHz-10GHz

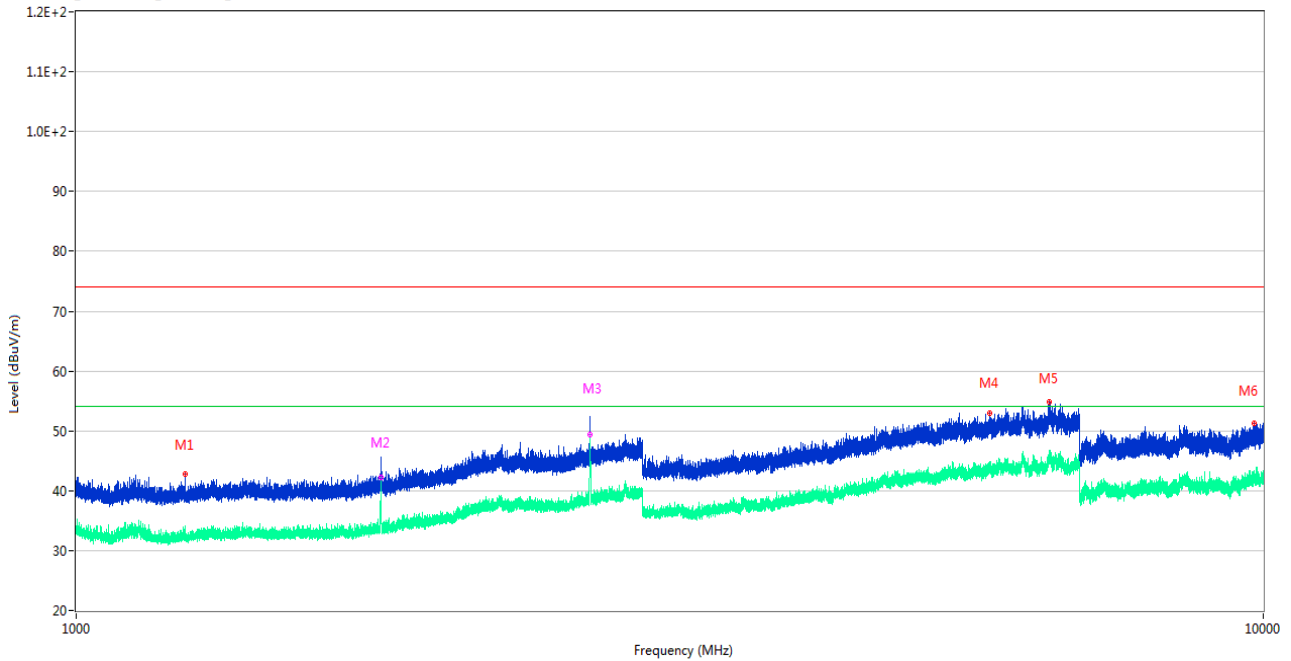

No.	Frequency (MHz)	Results (dBuV/m)	Factor (dB)	Limit (dBuV/m)	Margin (dB)	Detector	Table (Degree)	Height (cm)	Antenna	Verdict
1	1234.600	42.71	-13.63	74.0	31.29	Peak	72.00	100	Horizontal	Pass
1**	1234.600	32.45	-13.63	54.0	21.55	AV	72.00	100	Horizontal	Pass
2	1806.700	44.82	-13.16	74.0	29.18	Peak	78.00	150	Horizontal	Pass
2**	1806.700	42.28	-13.16	54.0	11.72	AV	78.00	150	Horizontal	Pass
3	2711.300	50.23	-6.83	74.0	23.77	Peak	193.00	150	Horizontal	Pass
3**	2711.300	49.32	-6.83	54.0	4.68	AV	193.00	150	Horizontal	Pass
4	5879.000	53.00	-1.31	74.0	21.00	Peak	121.00	400	Horizontal	Pass
4**	5879.000	43.71	-1.31	54.0	10.29	AV	121.00	400	Horizontal	Pass
5	6605.200	54.84	1.22	74.0	19.16	Peak	281.00	150	Horizontal	Pass
5**	6605.200	45.82	1.22	54.0	8.18	AV	281.00	150	Horizontal	Pass
6	9821.050	51.17	-0.00	74.0	22.83	Peak	268.00	150	Horizontal	Pass
6**	9821.050	43.43	-0.00	54.0	10.57	AV	268.00	150	Horizontal	Pass

LoRa (1523kHz) LOW CHANNEL 1 GHz to 10 GHz, ANT V

RE Test case\_FCC Part 15C\_FCC 15.249\_1GHz-10GHz

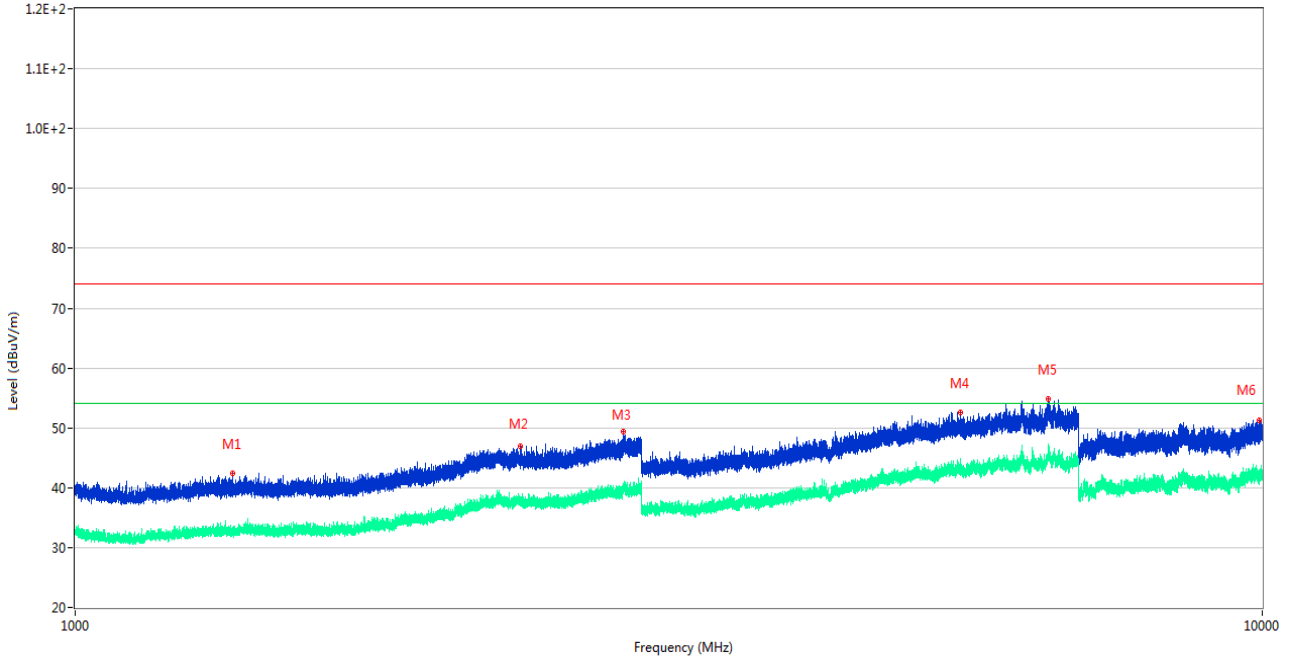

No.	Frequency (MHz)	Results (dBuV/m)	Factor (dB)	Limit (dBuV/m)	Margin (dB)	Detector	Table (Degree)	Height (cm)	Antenna	Verdict
1	1358.400	42.35	-13.56	74.0	31.65	Peak	111.00	300	Vertical	Pass
1**	1358.400	32.76	-13.56	54.0	21.24	AV	111.00	300	Vertical	Pass
2	2373.500	47.01	-7.95	74.0	26.99	Peak	354.00	200	Vertical	Pass
2**	2373.500	37.31	-7.95	54.0	16.69	AV	354.00	200	Vertical	Pass
3	2896.300	49.46	-4.53	74.0	24.54	Peak	122.00	200	Vertical	Pass
3**	2896.300	40.52	-4.53	54.0	13.48	AV	122.00	200	Vertical	Pass
4	5572.600	52.54	-1.96	74.0	21.46	Peak	198.00	400	Vertical	Pass
4**	5572.600	43.04	-1.96	54.0	10.96	AV	198.00	400	Vertical	Pass
5	6607.600	54.78	1.52	74.0	19.22	Peak	260.00	150	Vertical	Pass
5**	6607.600	46.29	1.52	54.0	7.71	AV	260.00	150	Vertical	Pass
6	9933.550	51.31	-1.07	74.0	22.69	Peak	118.00	100	Vertical	Pass
6**	9933.550	41.77	-1.07	54.0	12.23	AV	118.00	100	Vertical	Pass

LoRa (1523kHz) MIDDLE CHANNEL 1 GHz to 10 GHz, ANT H

RE Test case\_FCC Part 15C\_FCC 15.249\_1GHz-10GHz

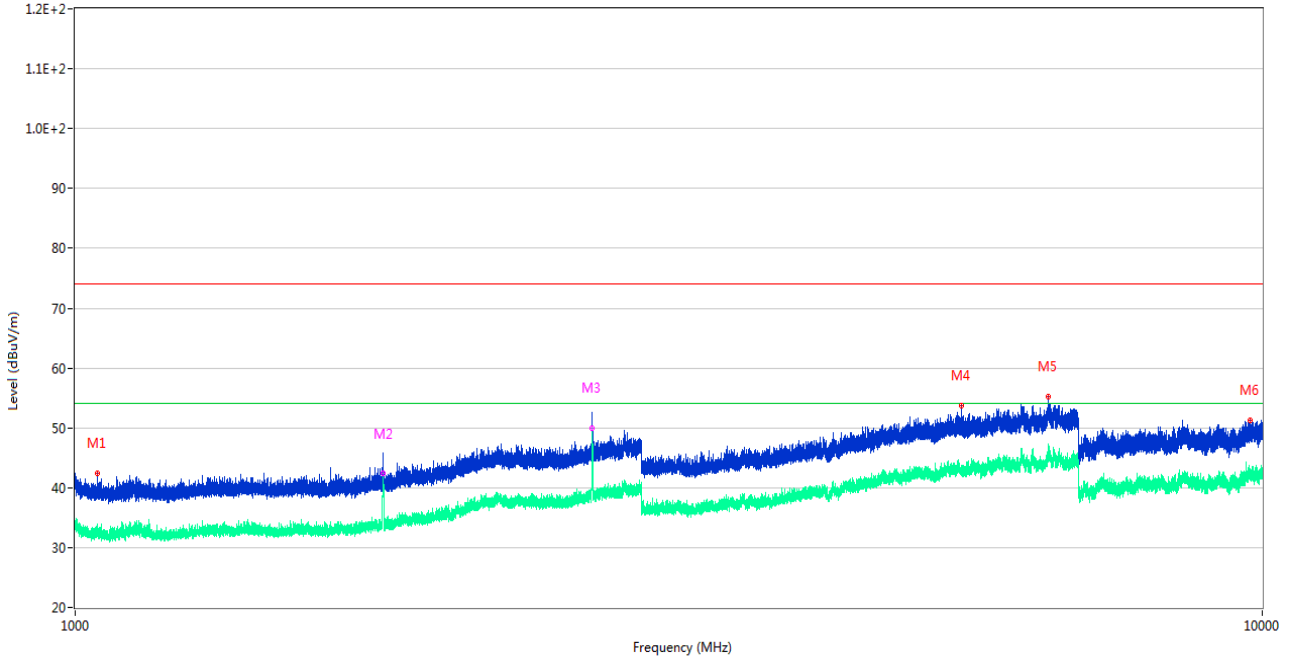

No.	Frequency (MHz)	Results (dBuV/m)	Factor (dB)	Limit (dBuV/m)	Margin (dB)	Detector	Table (Degree)	Height (cm)	Antenna	Verdict
1	1044.000	42.41	-13.33	74.0	31.59	Peak	340.00	400	Horizontal	Pass
1**	1044.000	32.28	-13.33	54.0	21.72	AV	340.00	400	Horizontal	Pass
2	1818.600	43.16	-12.91	74.0	30.84	Peak	59.00	150	Horizontal	Pass
2**	1818.600	42.33	-12.91	54.0	11.67	AV	59.00	150	Horizontal	Pass
3	2724.600	52.25	-6.59	74.0	21.75	Peak	175.00	150	Horizontal	Pass
3**	2724.600	49.89	-6.59	54.0	4.11	AV	175.00	150	Horizontal	Pass
4	5580.200	53.74	-1.83	74.0	20.26	Peak	33.00	200	Horizontal	Pass
4**	5580.200	42.99	-1.83	54.0	11.01	AV	33.00	200	Horizontal	Pass
5	6608.800	55.22	1.60	74.0	18.78	Peak	33.00	150	Horizontal	Pass
5**	6608.800	46.99	1.60	54.0	7.01	AV	33.00	150	Horizontal	Pass
6	9767.200	51.29	-0.35	74.0	22.71	Peak	359.00	200	Horizontal	Pass
6**	9767.200	41.67	-0.35	54.0	12.33	AV	359.00	200	Horizontal	Pass



LoRa (1523kHz) MIDDLE CHANNEL 1 GHz to 10 GHz, ANT V

RE Test case\_FCC Part 15C\_FCC 15.249\_1GHz-10GHz

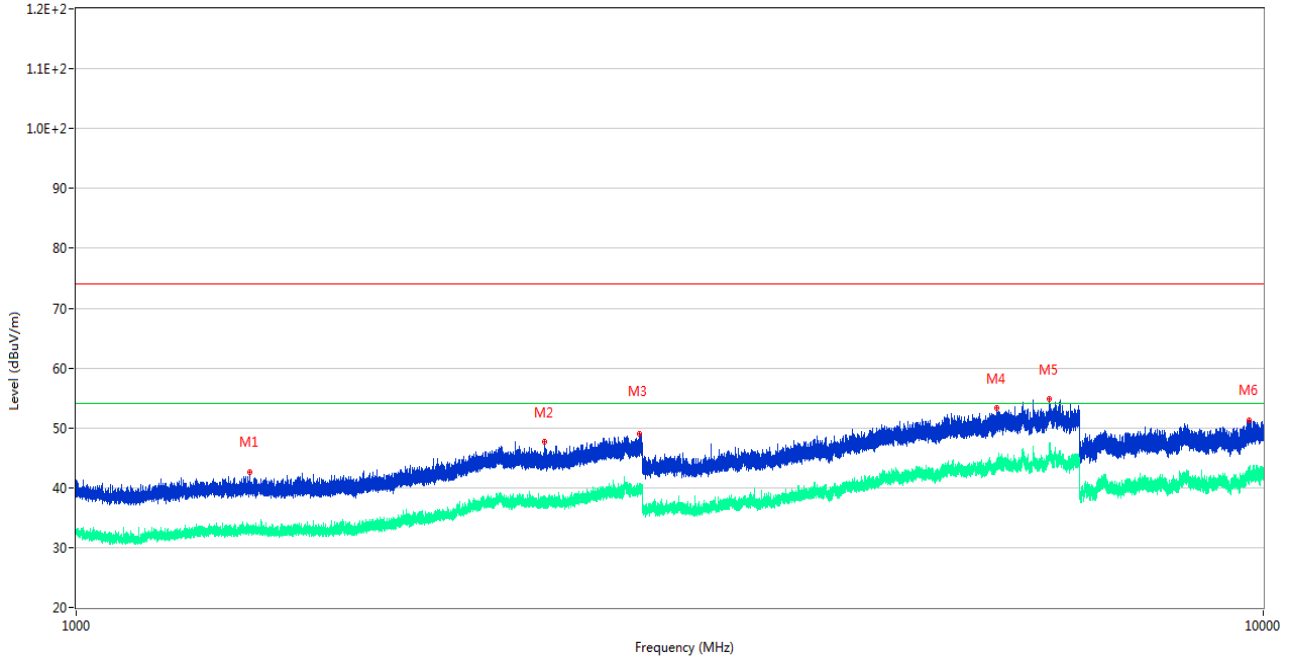

No.	Frequency (MHz)	Results (dBuV/m)	Factor (dB)	Limit (dBuV/m)	Margin (dB)	Detector	Table (Degree)	Height (cm)	Antenna	Verdict
1	1401.600	42.68	-13.38	74.0	31.32	Peak	98.00	400	Vertical	Pass
1**	1401.600	32.37	-13.38	54.0	21.63	AV	98.00	400	Vertical	Pass
2	2480.600	47.65	-8.29	74.0	26.35	Peak	340.00	400	Vertical	Pass
2**	2480.600	37.91	-8.29	54.0	16.09	AV	340.00	400	Vertical	Pass
3	2981.500	49.06	-4.56	74.0	24.94	Peak	358.00	150	Vertical	Pass
3**	2981.500	39.11	-4.56	54.0	14.89	AV	358.00	150	Vertical	Pass
4	5968.400	53.30	-1.16	74.0	20.70	Peak	264.00	400	Vertical	Pass
4**	5968.400	44.11	-1.16	54.0	9.89	AV	264.00	400	Vertical	Pass
5	6608.200	54.75	1.56	74.0	19.25	Peak	38.00	200	Vertical	Pass
5**	6608.200	46.10	1.56	54.0	7.90	AV	38.00	200	Vertical	Pass
6	9730.000	51.29	-0.51	74.0	22.71	Peak	256.00	400	Vertical	Pass
6**	9730.000	41.72	-0.51	54.0	12.28	AV	256.00	400	Vertical	Pass

LoRa (1523kHz) HIGH CHANNEL 1 GHz to 10 GHz, ANT H

RE Test case\_FCC Part 15C\_FCC 15.249\_1GHz-10GHz

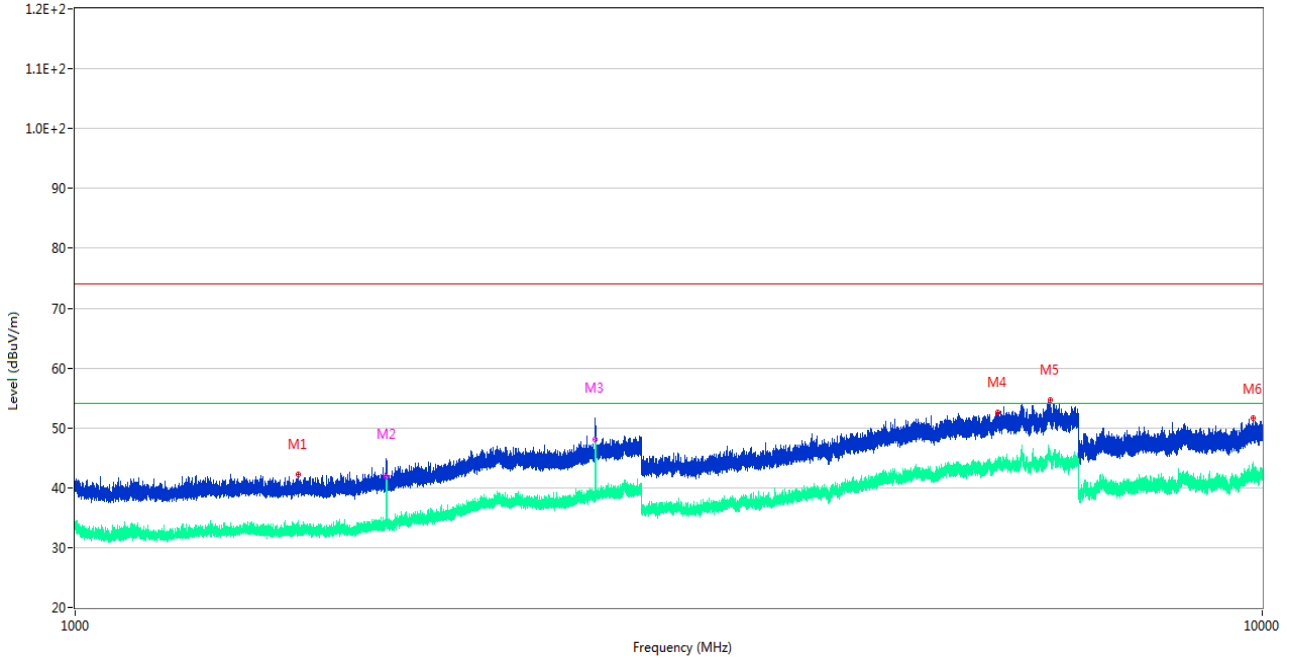

No.	Frequency (MHz)	Results (dBuV/m)	Factor (dB)	Limit (dBuV/m)	Margin (dB)	Detector	Table (Degree)	Height (cm)	Antenna	Verdict
1	1540.500	42.27	-13.39	74.0	31.73	Peak	360.00	400	Horizontal	Pass
1**	1540.500	32.41	-13.39	54.0	21.59	AV	360.00	400	Horizontal	Pass
2	1828.100	44.45	-12.67	74.0	29.55	Peak	93.00	150	Horizontal	Pass
2**	1828.100	41.86	-12.67	54.0	12.14	AV	93.00	150	Horizontal	Pass
3	2742.400	49.54	-7.04	74.0	24.46	Peak	172.00	150	Horizontal	Pass
3**	2742.400	48.15	-7.04	54.0	5.85	AV	172.00	150	Horizontal	Pass
4	5990.600	52.67	-0.86	74.0	21.33	Peak	170.00	100	Horizontal	Pass
4**	5990.600	43.75	-0.86	54.0	10.25	AV	170.00	100	Horizontal	Pass
5	6633.000	54.72	0.67	74.0	19.28	Peak	211.00	100	Horizontal	Pass
5**	6633.000	44.44	0.67	54.0	9.56	AV	211.00	100	Horizontal	Pass
6	9822.401	51.60	-0.05	74.0	22.40	Peak	180.00	200	Horizontal	Pass
6**	9822.401	42.40	-0.05	54.0	11.60	AV	180.00	200	Horizontal	Pass

LoRa (1523kHz) HIGH CHANNEL 1 GHz to 10 GHz, ANT V

RE Test case\_FCC Part 15C\_FCC 15.249\_1GHz-10GHz

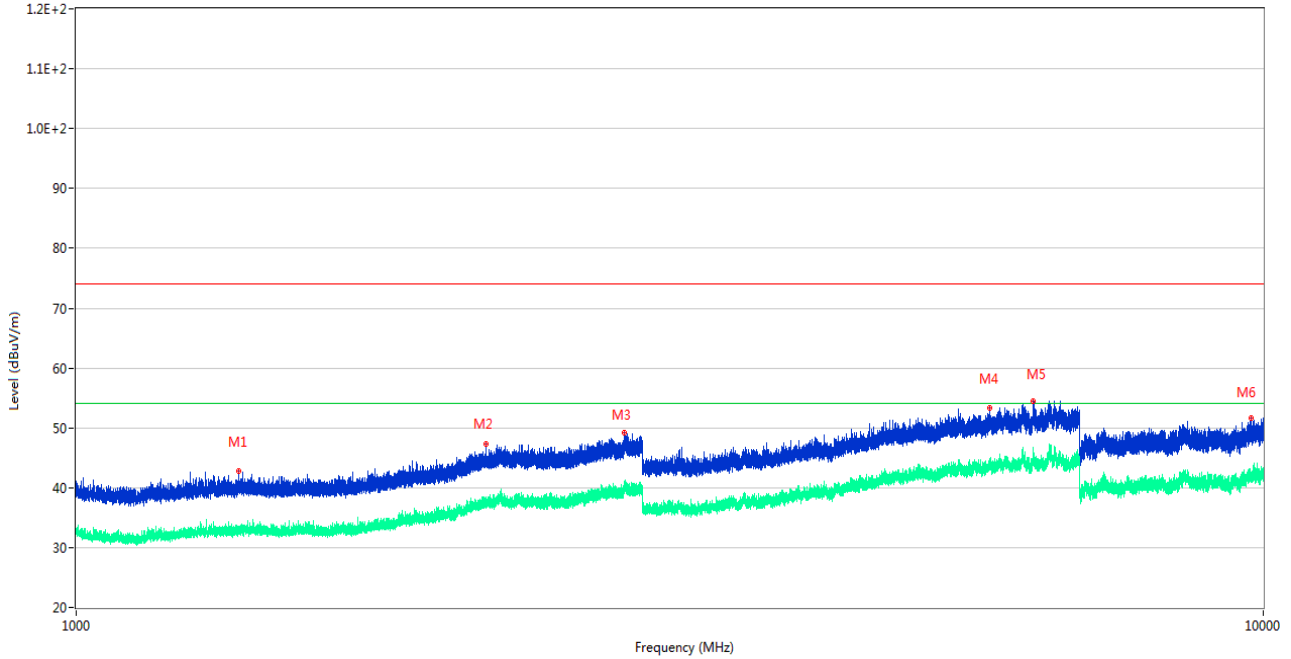

No.	Frequency (MHz)	Results (dBuV/m)	Factor (dB)	Limit (dBuV/m)	Margin (dB)	Detector	Table (Degree)	Height (cm)	Antenna	Verdict
1	1369.500	42.75	-13.52	74.0	31.25	Peak	5.00	100	Vertical	Pass
1**	1369.500	33.20	-13.52	54.0	20.80	AV	5.00	100	Vertical	Pass
2	2216.200	47.23	-9.12	74.0	26.77	Peak	316.00	300	Vertical	Pass
2**	2216.200	37.22	-9.12	54.0	16.78	AV	316.00	300	Vertical	Pass
3	2896.400	49.15	-4.51	74.0	24.85	Peak	169.00	150	Vertical	Pass
3**	2896.400	39.58	-4.51	54.0	14.42	AV	169.00	150	Vertical	Pass
4	5883.400	53.27	-1.11	74.0	20.73	Peak	18.00	100	Vertical	Pass
4**	5883.400	43.62	-1.11	54.0	10.38	AV	18.00	100	Vertical	Pass
5	6403.400	54.55	0.11	74.0	19.45	Peak	358.00	200	Vertical	Pass
5**	6403.400	45.51	0.11	54.0	8.49	AV	358.00	200	Vertical	Pass
6	9770.500	51.61	-0.33	74.0	22.39	Peak	167.00	200	Vertical	Pass
6**	9770.500	42.04	-0.33	54.0	11.96	AV	167.00	200	Vertical	Pass

## A.7 Band Edge (Restricted-band band-edge)

Note <sup>1</sup>: The lowest and highest channels are tested to verify the band edge emissions. Please refer to the following the plots for emissions values.

Note <sup>2</sup>: The test data all are tested in the vertical and horizontal antenna which the trace is max hold. So these plots have shown the worst case.

Note <sup>3</sup>: According the ANSI C63.10-2013, where limits are specified for both average and peak (or quasi-peak) detector functions, if the peak (or quasi-peak) measured value complies with the average limit, it is unnecessary to perform an average measurement.

Note <sup>4</sup>: The Level (dBuV/m) has been corrected by factor.

### Test Data and Plots

#### LoRa (500kHz) LOW CHANNEL

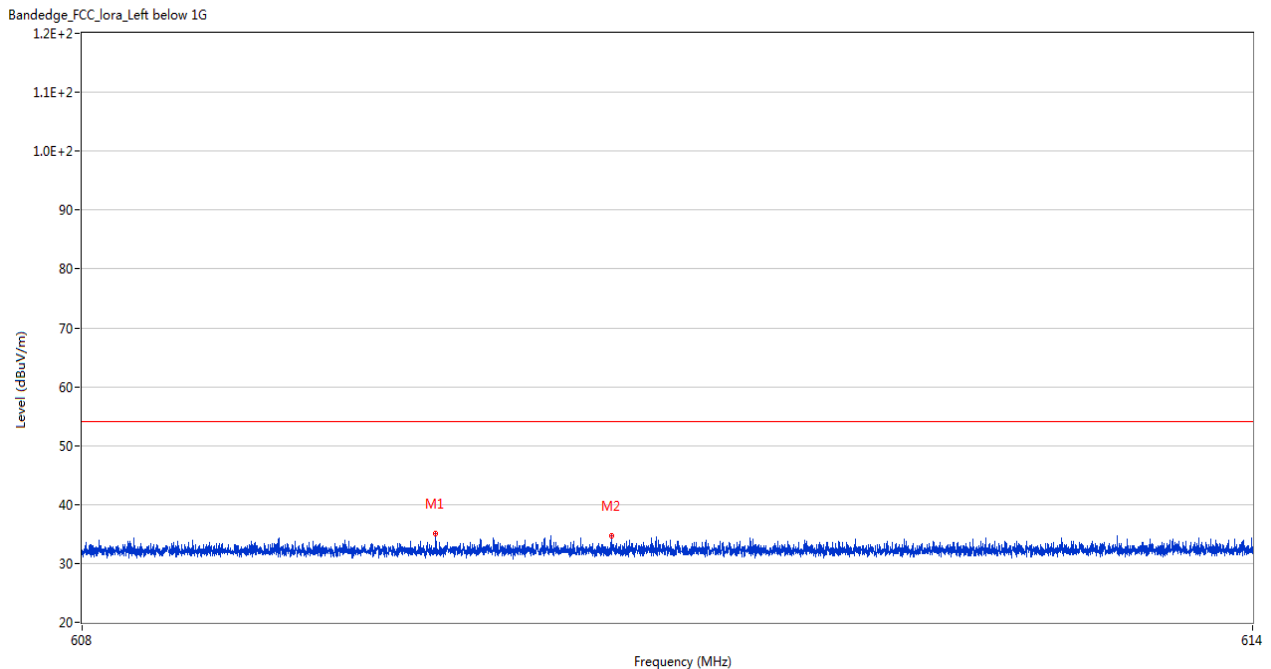

No.	Frequency (MHz)	Results (dBuV/m)	Factor (dB)	Limit (dBuV/m)	Margin (dB)	Detector	Table (Degree)	Height (cm)	Antenna	Verdict
1	609.807	35.14	-2.93	54.0	18.86	Peak	188.00	200	Horizontal	Pass
2	610.705	34.74	-2.91	54.0	19.26	Peak	211.00	150	Horizontal	Pass

LoRa (500kHz) HIGH CHANNEL

Bandedge\_FCC\_lora\_Right below 1G

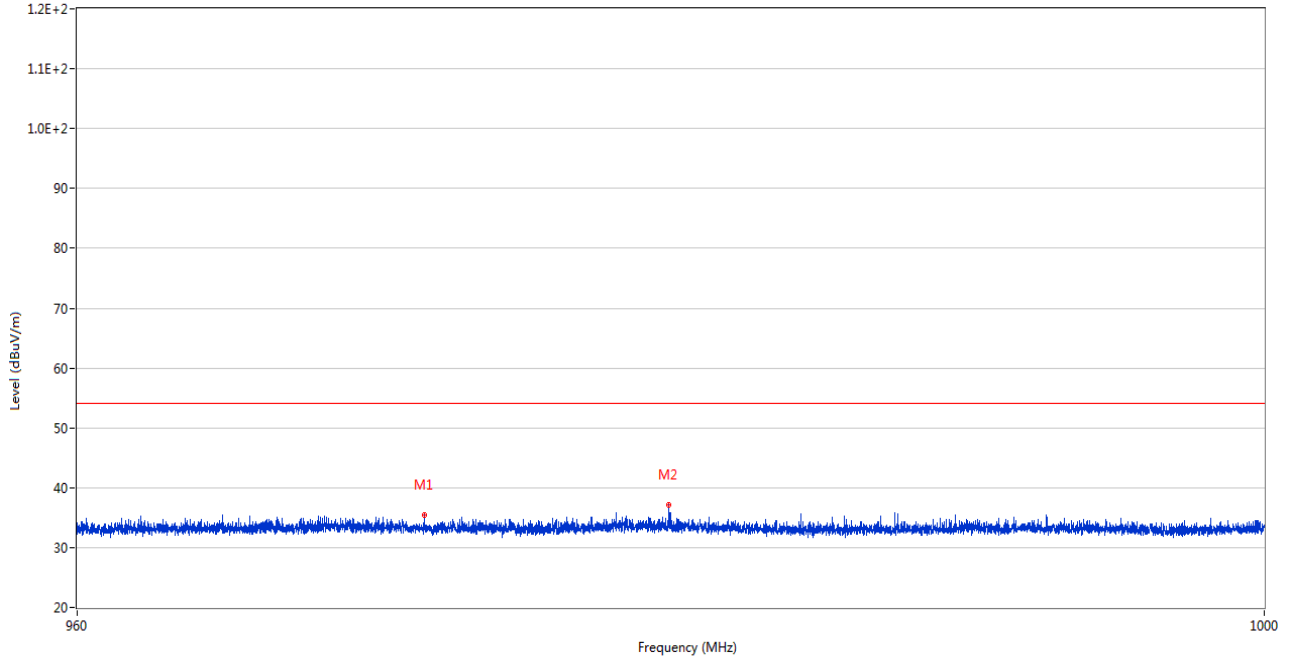

No.	Frequency (MHz)	Results (dBuV/m)	Factor (dB)	Limit (dBuV/m)	Margin (dB)	Detector	Table (Degree)	Height (cm)	Antenna	Verdict
1	971.533	35.38	-9.31	54.0	18.62	Peak	118.00	300	Horizontal	Pass
2	979.740	37.16	-9.45	54.0	16.84	Peak	48.00	200	Horizontal	Pass

LoRa (500kHz) HIGH CHANNEL

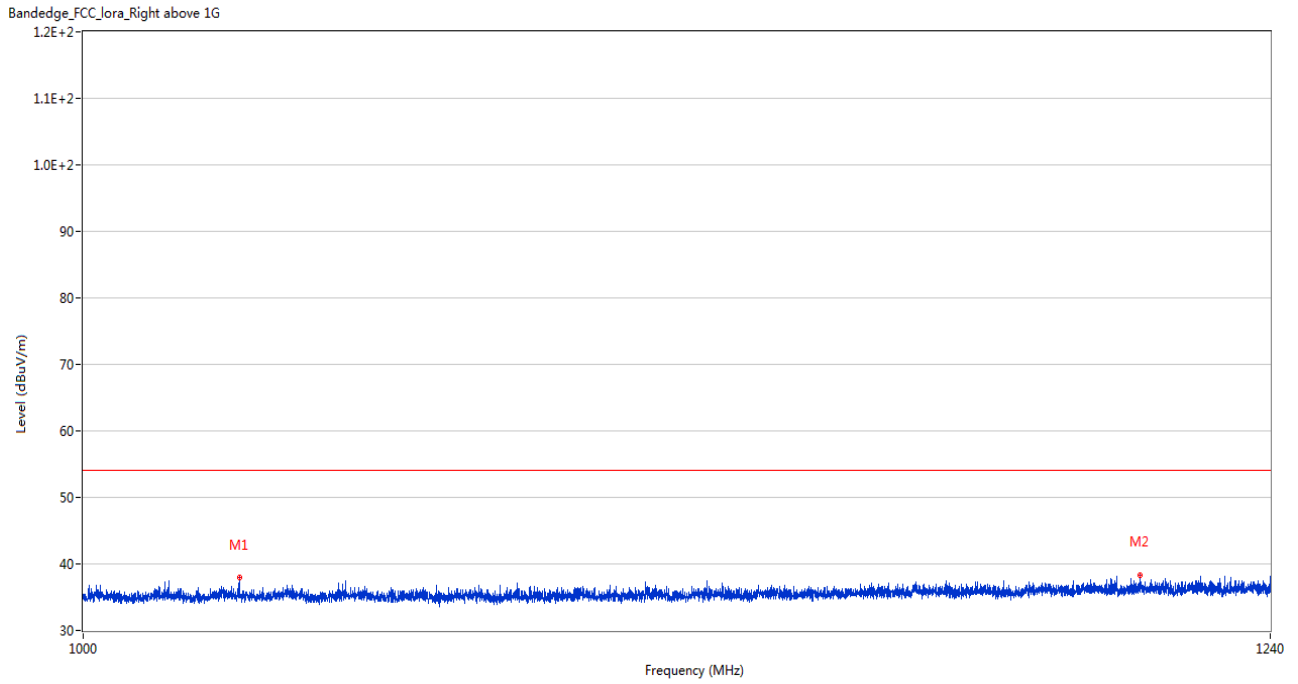

No.	Frequency (MHz)	Results (dBuV/m)	Factor (dB)	Limit (dBuV/m)	Margin (dB)	Detector	Table (Degree)	Height (cm)	Antenna	Verdict
1	1028.720	37.94	-17.93	54.0	16.06	Peak	359.00	150	Horizontal	Pass
2	1211.120	38.38	-17.84	54.0	15.62	Peak	11.00	150	Horizontal	Pass

LoRa (1523kHz) LOW CHANNEL

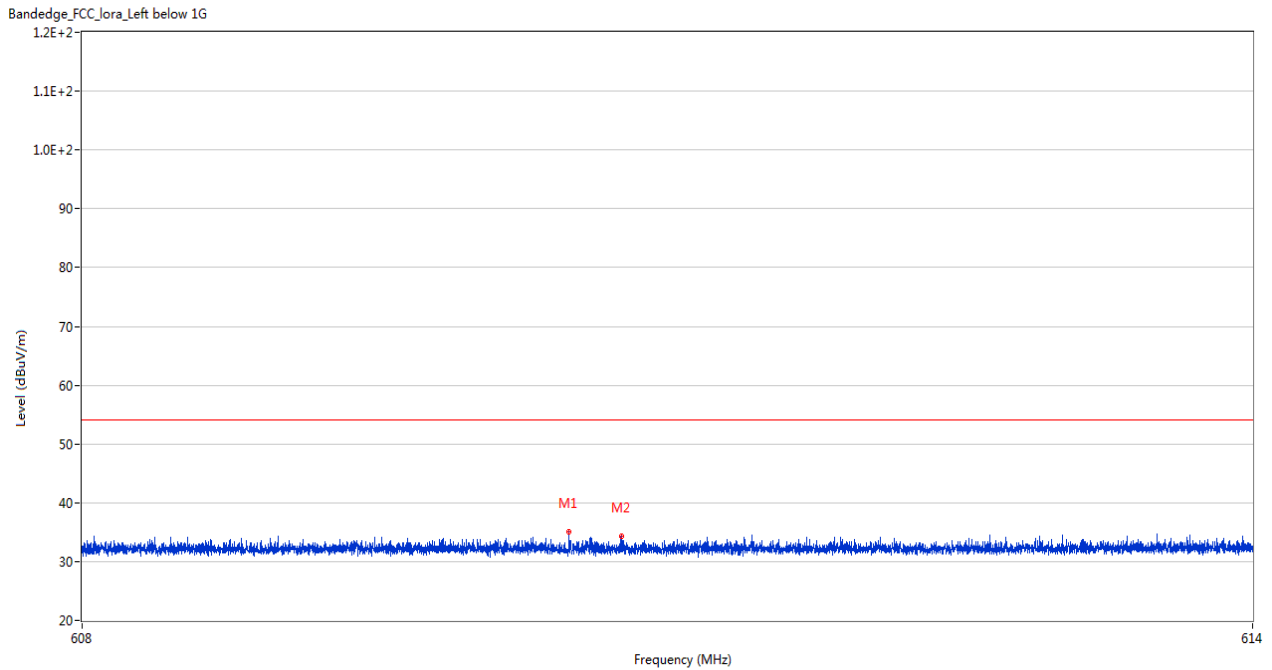

No.	Frequency (MHz)	Results (dBuV/m)	Factor (dB)	Limit (dBuV/m)	Margin (dB)	Detector	Table (Degree)	Height (cm)	Antenna	Verdict
1	610.490	35.06	-2.91	54.0	18.94	Peak	322.00	300	Horizontal	Pass
2	610.756	34.25	-2.91	54.0	19.75	Peak	314.00	200	Horizontal	Pass

LoRa (1523kHz) HIGH CHANNEL

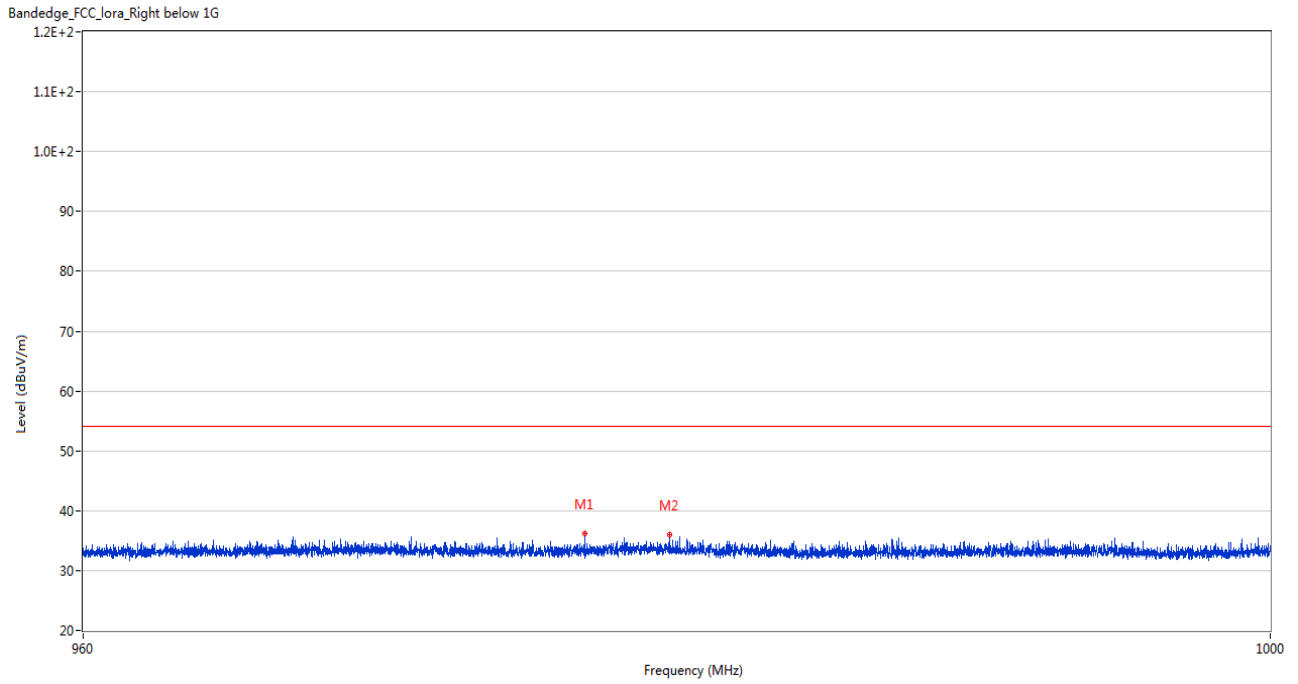

No.	Frequency (MHz)	Results (dBuV/m)	Factor (dB)	Limit (dBuV/m)	Margin (dB)	Detector	Table (Degree)	Height (cm)	Antenna	Verdict
1	976.700	36.12	-9.52	54.0	17.88	Peak	95.00	300	Horizontal	Pass
2	979.560	35.93	-9.45	54.0	18.07	Peak	344.00	200	Horizontal	Pass



LoRa (1523kHz) HIGH CHANNEL

Bandedge\_FCC\_lora\_Right above 1G

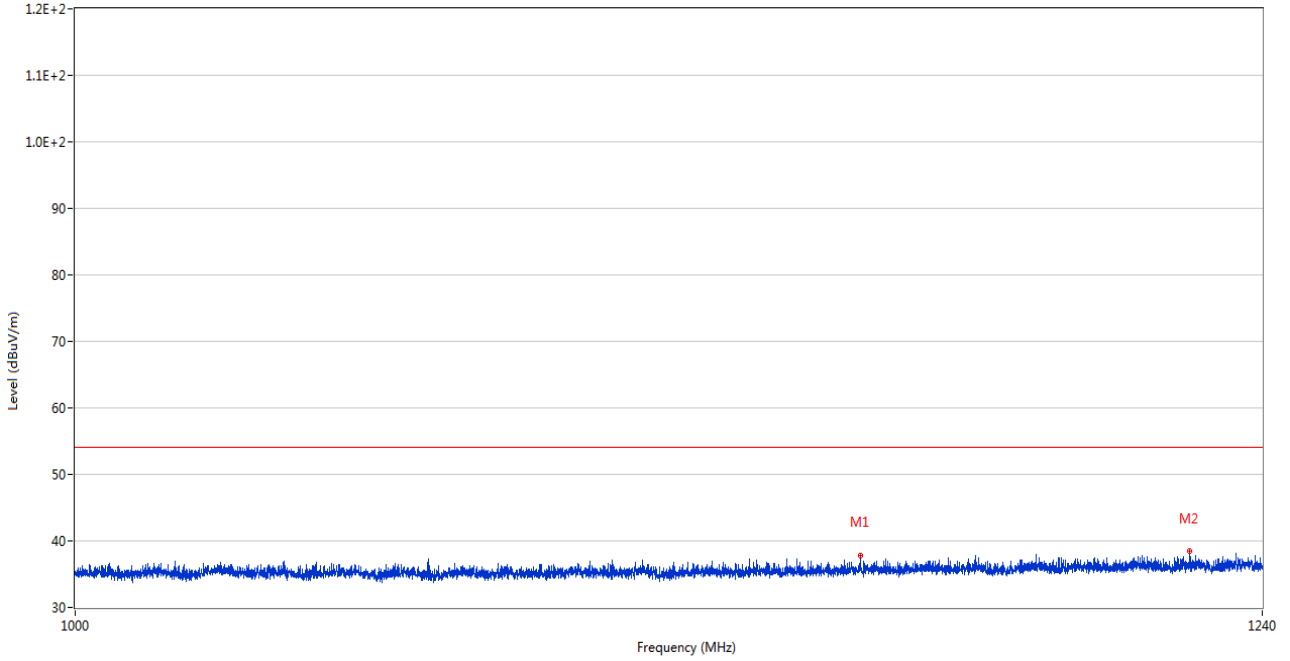

No.	Frequency (MHz)	Results (dBuV/m)	Factor (dB)	Limit (dBuV/m)	Margin (dB)	Detector	Table (Degree)	Height (cm)	Antenna	Verdict
1	1152.880	37.83	-18.03	54.0	16.17	Peak	192.00	150	Horizontal	Pass
2	1223.840	38.40	-17.83	54.0	15.60	Peak	105.00	150	Horizontal	Pass

## A.8 Power Spectral Density (PSD)

### Duty Cycle Test Data

Band	On Time (ms)	On+Off Time (ms)	Duty Cycle (%)	Duty Factor (10 log (1/x))
LoRa (500kHz)	97.6	219.7	44.42%	3.52
LoRa (1523kHz)	570.6	2608.0	21.88%	6.60

Note: Spectral power density = Measured Spectral power density + Duty Factor.

### Power Spectral Density Test Data

LoRa (500kHz)				
Channel	Measured Spectral power density (dBm/3kHz)	Spectral power density (dBm/3kHz)	Limit (dBm/3kHz)	Verdict
Low	-1.10	2.42	8	Pass
Middle	-1.14	2.39	8	Pass
High	-0.94	2.58	8	Pass

LoRa (1523kHz)				
Channel	Measured Spectral power density (dBm/3kHz)	Spectral power density (dBm/3kHz)	Limit (dBm/3kHz)	Verdict
Low	-0.77	5.83	8	Pass
Middle	-0.68	5.92	8	Pass
High	-0.62	5.98	8	Pass

Test Plots

LoRa (500kHz) LOW CHANNEL

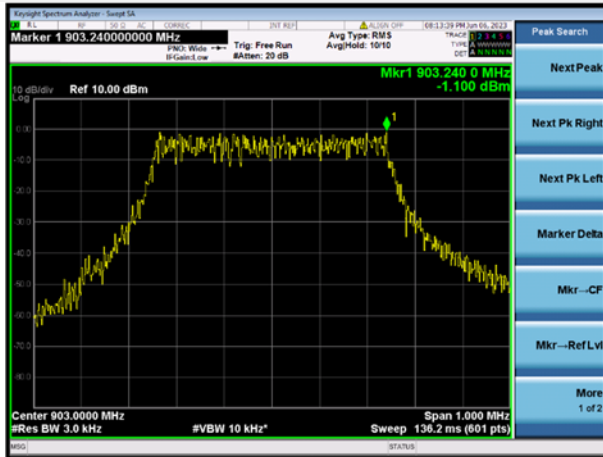

LoRa (500kHz) MIDDLE CHANNEL

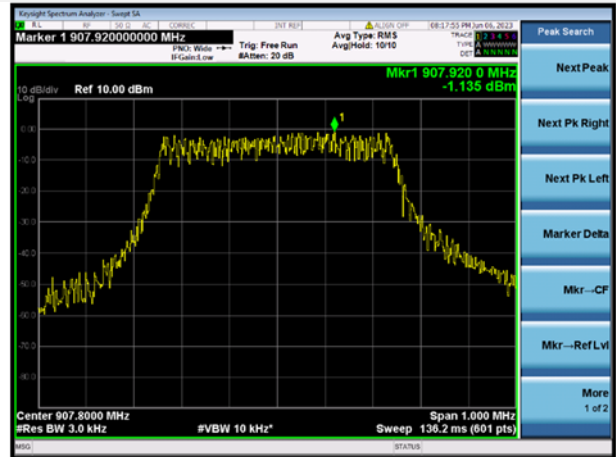

LoRa (500kHz) HIGH CHANNEL



LoRa (1523kHz) LOW CHANNEL

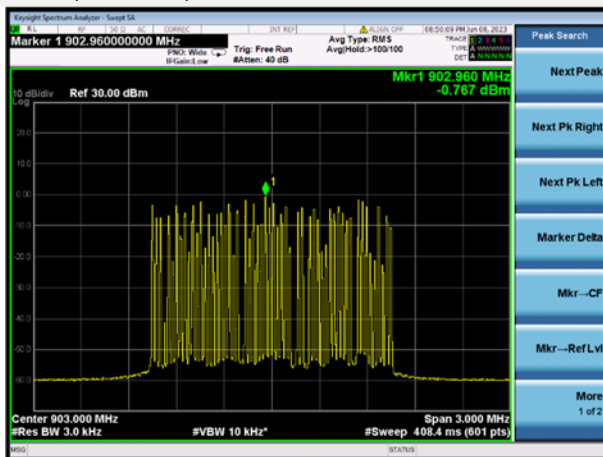

LoRa (1523kHz) MIDDLE CHANNEL

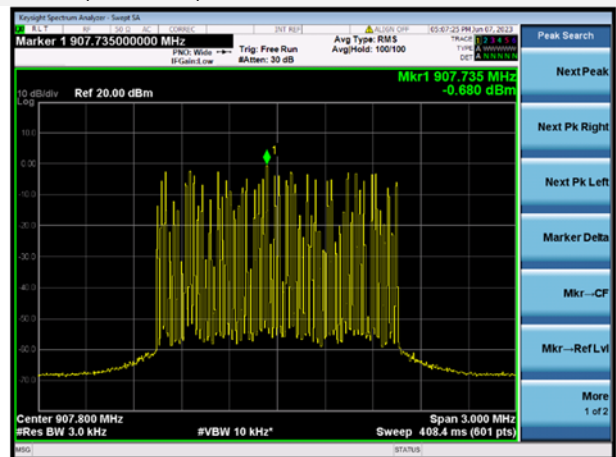

### LoRa (1523kHz) HIGH CHANNEL

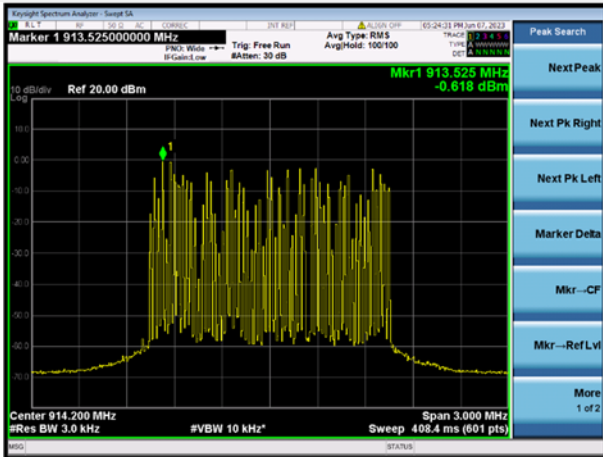

## **ANNEX B TEST SETUP PHOTOS**

Please refer the document “BL-SZ2351326-AR.PDF”.

## **ANNEX C EUT EXTERNAL PHOTOS**

Please refer the document “BL-SZ2351326-AW.PDF”.

## **ANNEX D EUT INTERNAL PHOTOS**

Please refer the document “BL-SZ2351326-AI.PDF”.

## Statement

1. The laboratory guarantees the scientificity, accuracy and impartiality of the test, and is responsible for all the information in the report, except the information provided by the customer. The customer is responsible for the impact of the information provided on the validity of the results.
2. The report without China inspection body and laboratory Mandatory Approval (CMA) mark has no effect of proving to the society.
3. For the report with CNAS mark or A2LA mark, the items marked with "☆" are not within the accredited scope.
4. This report is invalid if it is altered, without the signature of the testing and approval personnel, or without the "inspection and testing dedicated stamp" or test report stamp.
5. The test data and results are only valid for the tested samples provided by the customer.
6. This report shall not be partially reproduced without the written permission of the laboratory.
7. Any objection shall be raised to the laboratory within 30 days after receiving the report.

--END OF REPORT--