

This components within this section should be placed as close as possible, minimizing any stubs. Wire traces should have an impedance as close as possible to 50ohms.

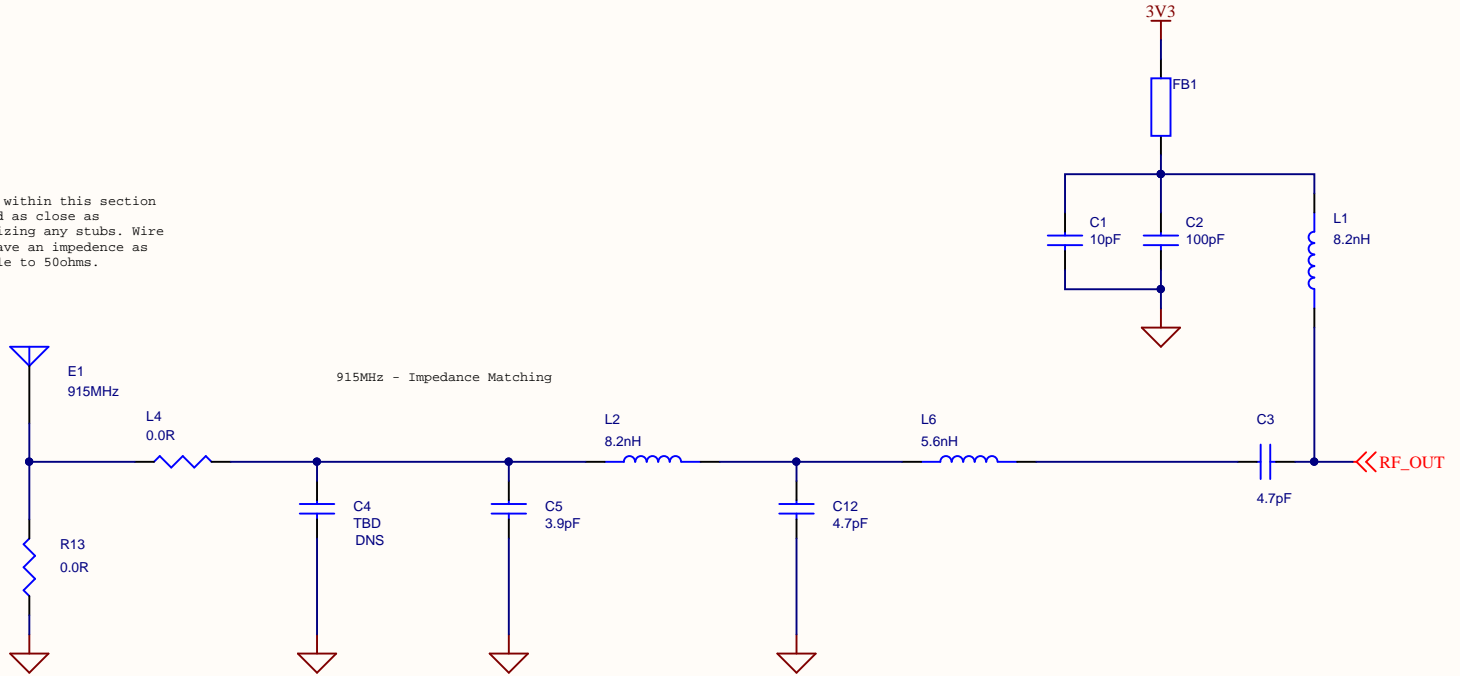

Title		
Antenna Impedance Matching		
Size	Document Number	Rev
A	SCH-000026B	B
Date:	Sheet	1 of 4

R3/R4 are placeholders, the pads are shorted, but can be cut to allow current measurements of the final assembly

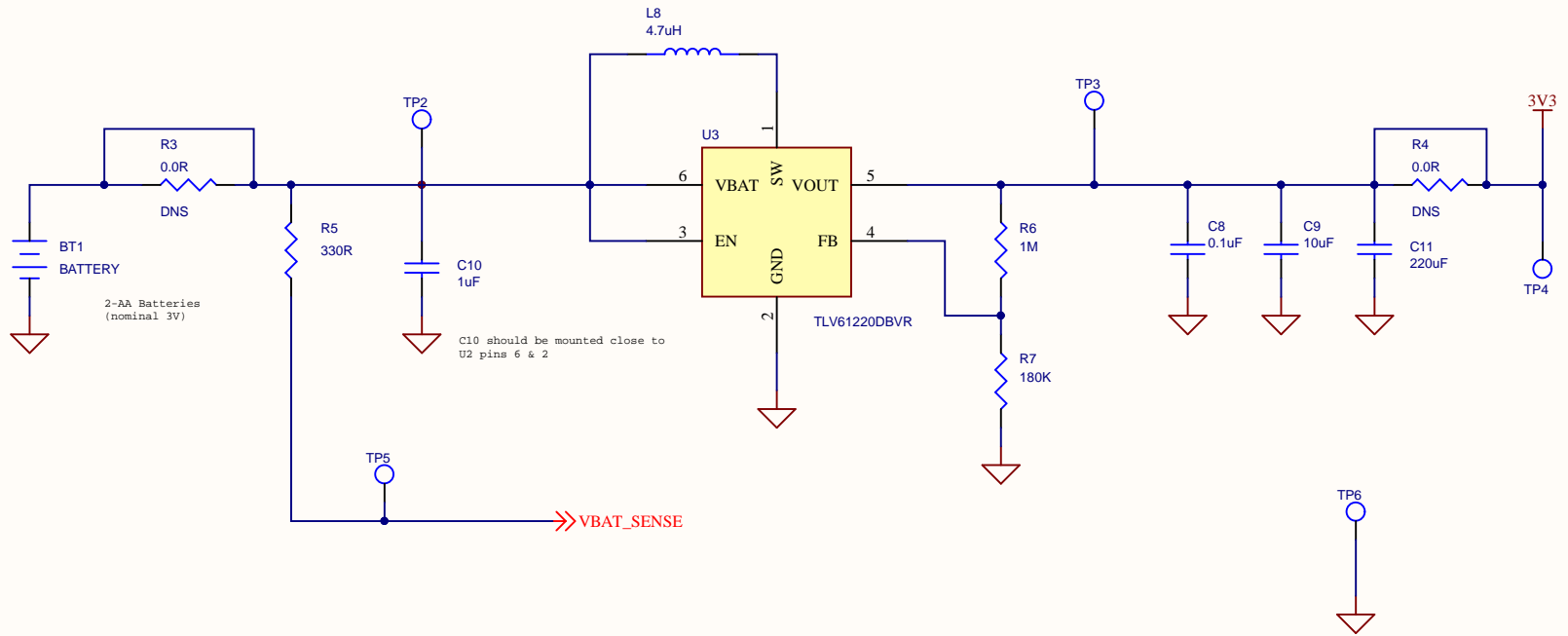

Title		
Power Supply		
Size	Document Number	Rev
A	SCH-000026B	B
Date:	Sheet	3 of 4

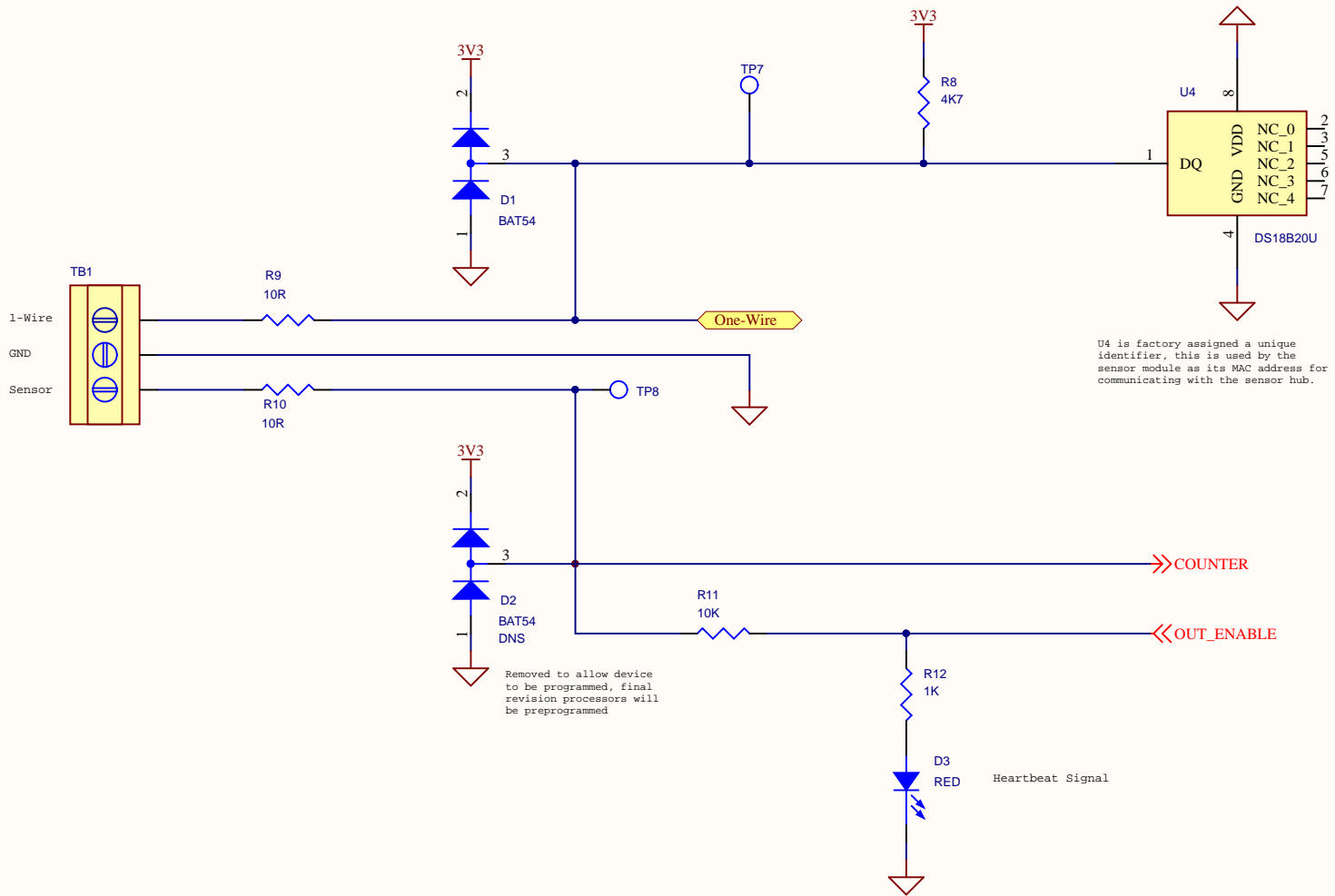

U4 is factory assigned a unique identifier, this is used by the sensor module as its MAC address for communicating with the sensor hub.

Removed to allow device to be programmed, final revision processors will be preprogrammed

Title		
Sensor Inputs		
Size	Document Number	Rev
A	SCH-000026B	B
Date:	Sheet 4 of 4	