

This components within this section should be placed as close as possible, minimizing any stubs. Wire traces should have an impedance as close as possible to 50ohms.

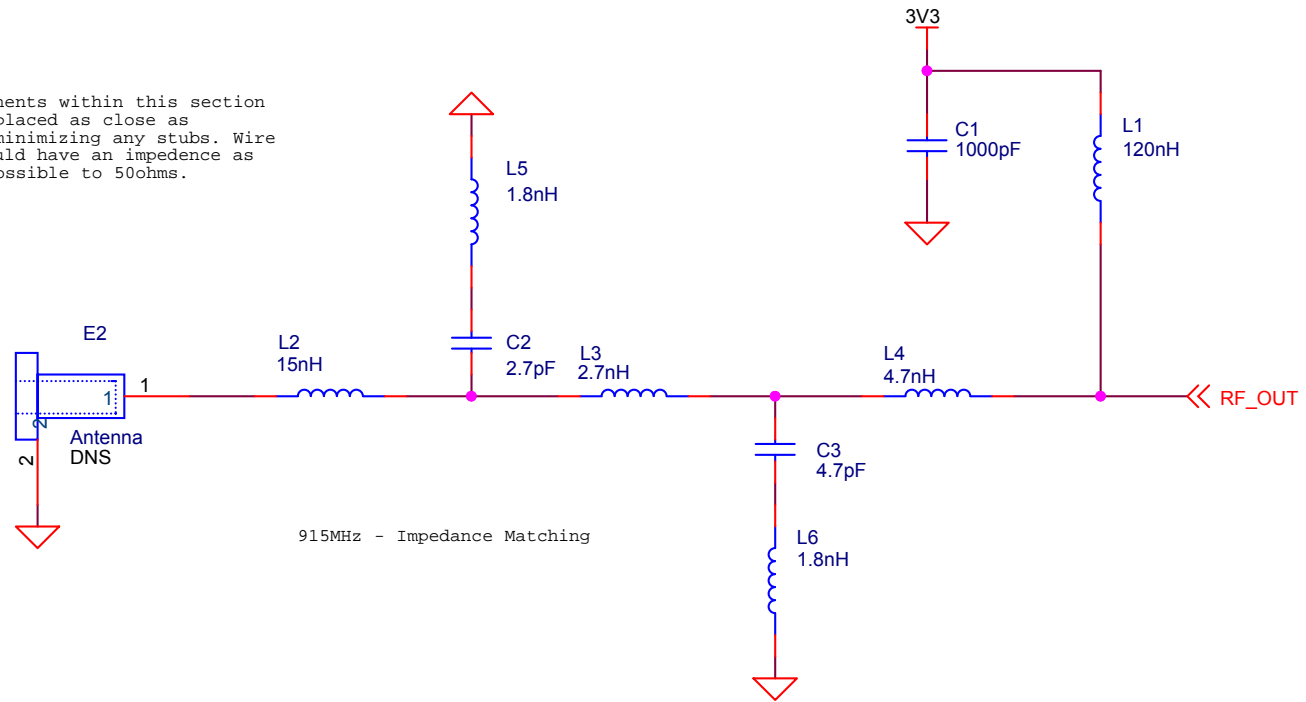

| | | |
|----------------------------|---------------------------|--------------|
| Title | | |
| Antenna Impedance Matching | | |
| Size | Document Number | Rev |
| A | SCH-00026 | 03 |
| Date: | Monday, February 27, 2017 | Sheet 1 of 4 |

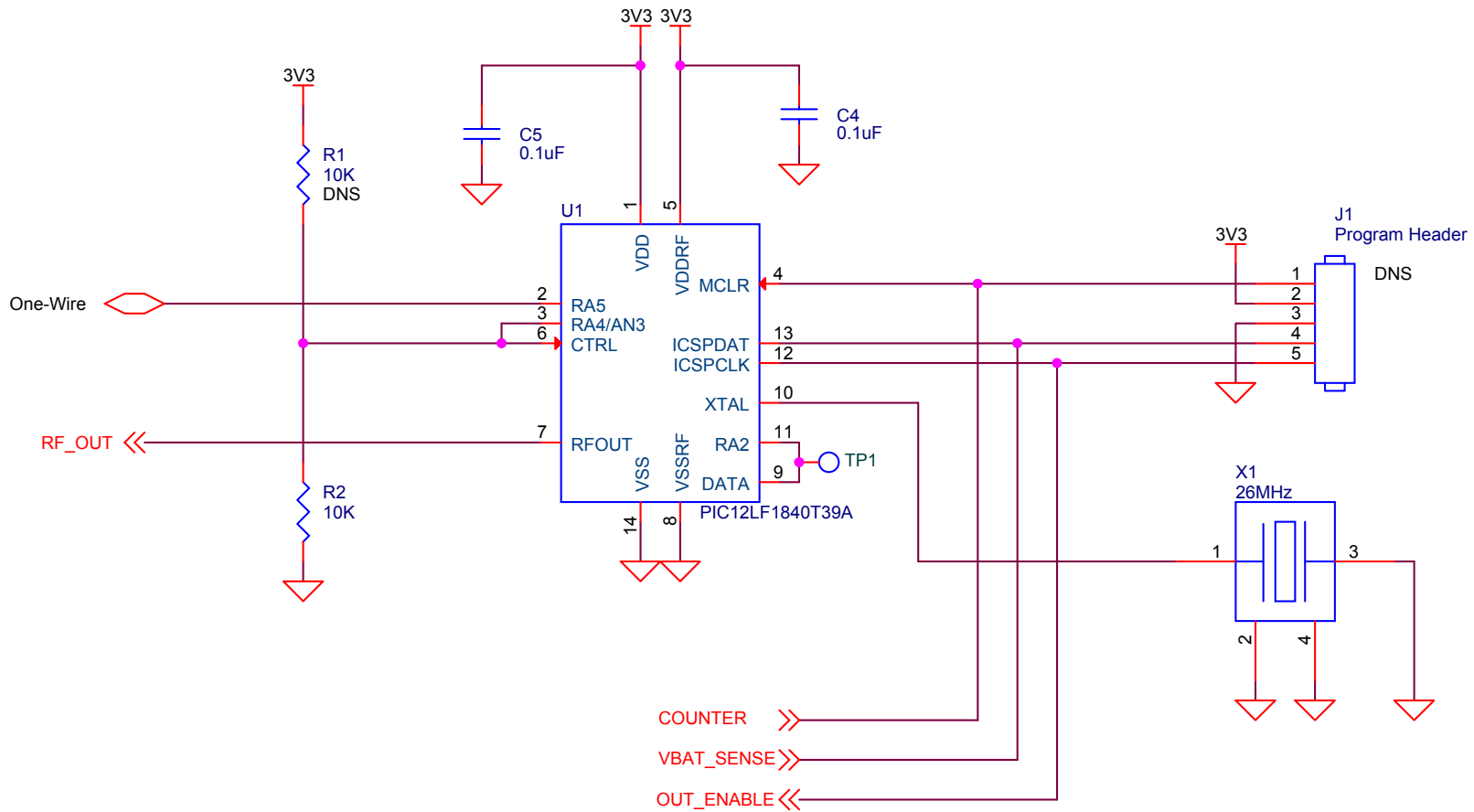

| | | |
|---------------------------------|------------------------------|--------------|
| Title | | |
| Low-Cost Wireless Sensor Module | | |
| Size | Document Number | Rev |
| A | SCH-000026 | 03 |
| Date: | Wednesday, February 01, 2017 | Sheet 2 of 4 |

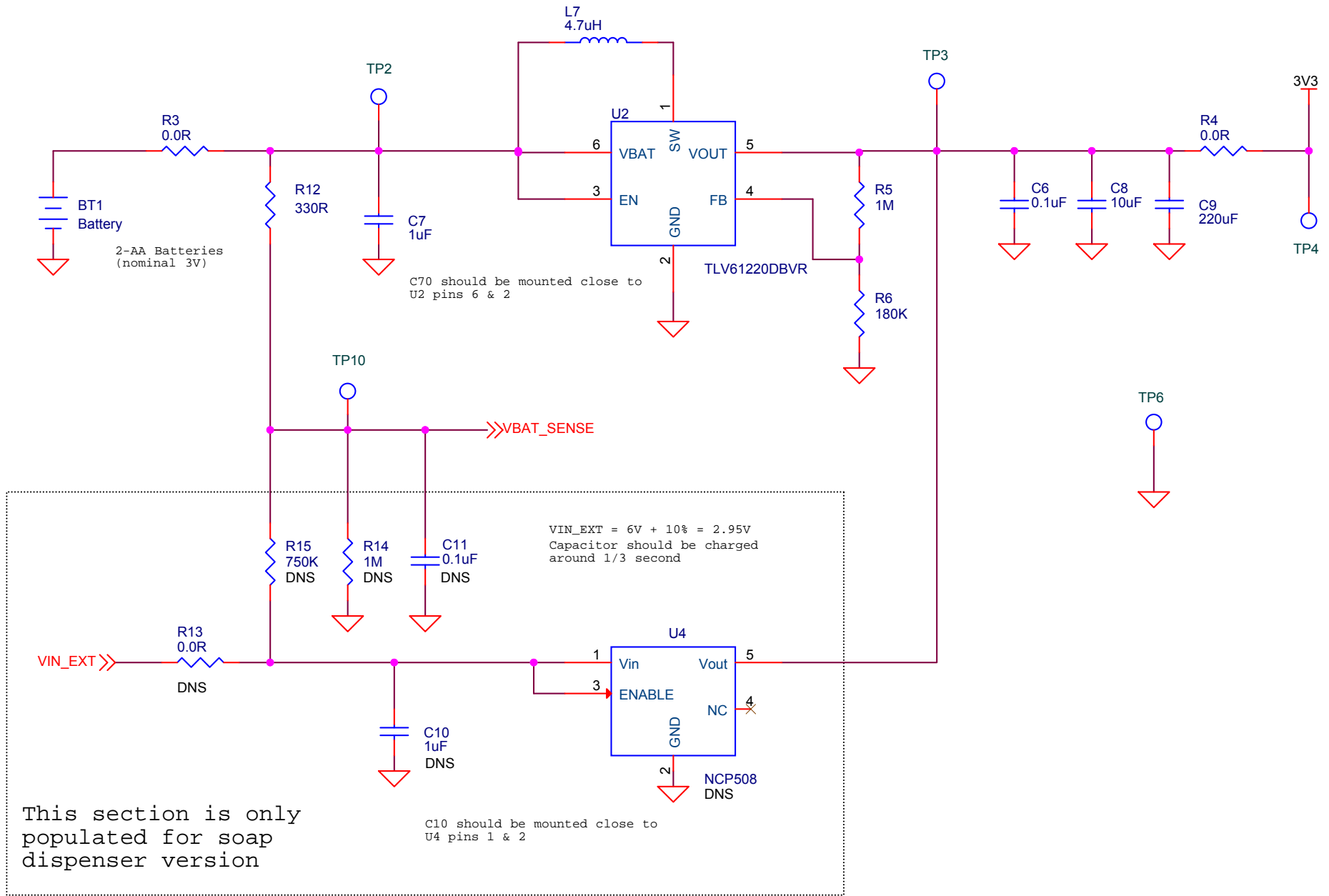

| | | |
|--------------|------------------------------|--------------|
| Title | | |
| Power Supply | | |
| Size | Document Number | Rev |
| A | SCH-000026 | 03 |
| Date: | Wednesday, February 01, 2017 | Sheet 3 of 4 |

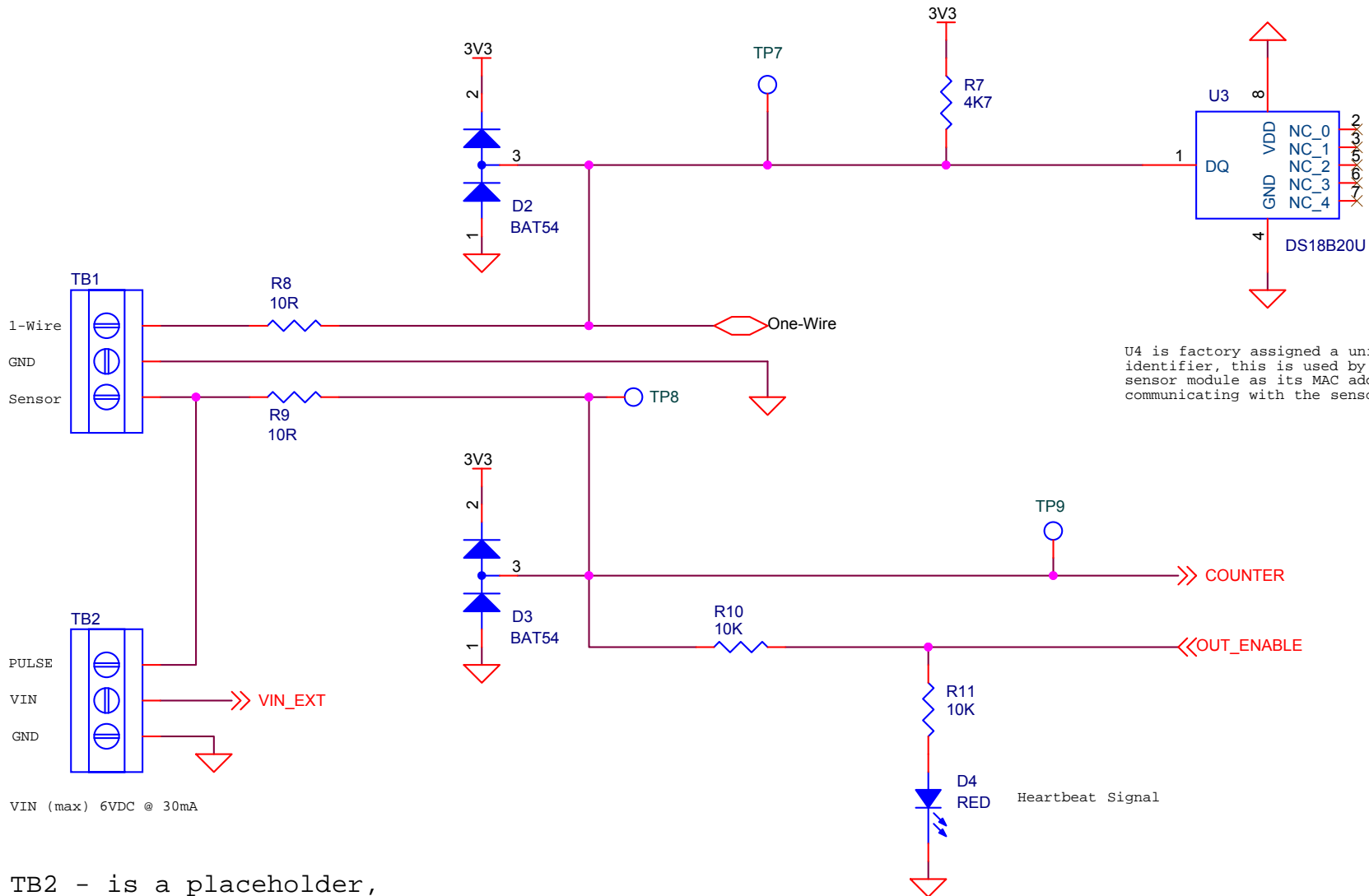

U4 is factory assigned a unique identifier, this is used by the sensor module as its MAC address for communicating with the sensor hub.

VIN (max) 6VDC @ 30mA

TB2 - is a placeholder, this interface connection to be determined - solder pads or connector?

| | | |
|---------------|------------------------------|--------------|
| Title | | |
| Sensor Inputs | | |
| Size | Document Number | Rev |
| A | SCH-00026 | 03 |
| Date: | Wednesday, February 01, 2017 | Sheet 4 of 4 |