



FCC Test Report

Equipment : 2 Port Gigabit Ethernet 11ac/11n Wireless Router
Brand Name : AirTies
Model No. : Air 4920
FCC ID : Z3WAIR49200
Standard : 47 CFR FCC Part 15.407
Operating Band : 5470 MHz – 5725 MHz
Applicant : AirTies Wireless Networks
Mithat Uluunlu Sokak No. 23 Esentepe, Sisli Istanbul
34394 Turkey
Manufacturer : AirTies Wireless Networks
Mithat Uluunlu Sokak No. 23 Esentepe, Sisli Istanbul
34394 Turkey
Function : Outdoor; Indoor; Fixed P2P
 Client
TPC Function : TPC

The product sample received on Nov. 23, 2016 and completely tested on Nov. 25, 2016. We, SPORTON, would like to declare that the tested sample has been evaluated in accordance with the procedures given in ANSI C63.10-2013 and shown compliance with the applicable technical standards.

The test results in this report apply exclusively to the tested model / sample. Without written approval of SPORTON INTERNATIONAL INC., the test report shall not be reproduced except in full.

Cliff Chang
SPORTON INTERNATIONAL INC.





Table of Contents

1	GENERAL DESCRIPTION	5
1.1	Information.....	5
1.2	Testing Applied Standards	8
1.3	Testing Location Information	8
1.4	Measurement Uncertainty	8
2	TEST CONFIGURATION OF EUT	9
2.1	Test Channel Mode	9
2.2	The Worst Case Measurement Configuration.....	10
2.3	EUT Operation during Test	10
2.4	Accessories	11
2.5	Support Equipment.....	11
2.6	Test Setup Diagram	12
3	TRANSMITTER TEST RESULT	14
3.1	Emission Bandwidth	14
3.2	Maximum Conducted Output Power	15
3.3	Peak Power Spectral Density.....	17
3.4	Unwanted Emissions.....	20
4	TEST EQUIPMENT AND CALIBRATION DATA	23
APPENDIX A. TEST RESULTS OF EMISSION BANDWIDTH		
APPENDIX B. TEST RESULTS OF MAXIMUM CONDUCTED OUTPUT POWER		
APPENDIX C. TEST RESULTS OF PEAK POWER SPECTRAL DENSITY		
APPENDIX D. TEST RESULTS OF UNWANTED EMISSIONS		
APPENDIX E. TEST PHOTOS		



Summary of Test Result

Conformance Test Specifications			
Report Clause	Ref. Std. Clause	Description	Result
1.1.2	15.203	Antenna Requirement	Complied
3.1	15.407(a)	Emission Bandwidth	Complied
3.2	15.407(a)	Maximum Conducted Output Power	Complied
3.3	15.407(a)	Peak Power Spectral Density	Complied
3.4	15.407(b)	Unwanted Emissions	Complied



1 General Description

1.1 Information

1.1.1 RF General Information

Frequency Range (MHz)	IEEE Std. 802.11	Ch. Frequency (MHz)	Channel Number
5470-5725	a, n (HT20), ac (VHT20)	5500-5700	100-140 [8]
5470-5725	n (HT40), ac (VHT40)	5510-5670	102-134 [3]
5470-5725	ac (VHT80)	5530	106 [1]

For straddle channel:

Frequency Range (MHz)	IEEE Std. 802.11	Ch. Frequency (MHz)	Channel Number
5470-5725	a, n (HT20), ac (VHT20)	5720	144 [1]
5470-5725	n (HT40), ac (VHT40)	5710	142 [1]
5470-5725	ac (VHT80)	5690	138 [1]

Band	Mode	BWch (MHz)	Nant
5.6G	11a	20	1
5.6G	HT20	20	3
5.6G	HT20,BF	20	3
5.6G	VHT20	20	3
5.6G	VHT20,BF	20	3
5.6G	HT40	40	3
5.6G	HT40,BF	40	3
5.6G	VHT40	40	3
5.6G	VHT40,BF	40	3
5.6G	VHT80	80	3
5.6G	VHT80,BF	80	3

Note:

- 5.6G is the 5.6GHz Band w/o TDWR (5.47-5.6GHz and 5.65-5.725GHz).
- 11a, HT20 and HT40 use a combination of OFDM-BPSK, QPSK, 16QAM, 64QAM modulation.
- VHT20, VHT40 and VHT80 use a combination of OFDM-BPSK, QPSK, 16QAM, 64QAM, 256QAM modulation.
- BWch is the nominal channel bandwidth.
- Nss-Min is the minimum number of spatial streams.
- Nant is the number of outputs. e.g., 2(2,3) means have 2 outputs for port 2 and port 3. 2 means have 2 outputs for port 1 and port 2.

1.1.2 Antenna Information

Ant.	Brand	Model Name	Antenna Type	Connector	Gain (dBi)	
					2.4GHz	5GHz
1	-	-	PCB Antenna	N/A	2.5	-
2	Airgain	N2420S-T-G50U	PIFA Antenna	I-PEX	2.5	-
3	-	-	PCB Antenna	N/A	-	0
4	-	-	PCB Antenna	N/A	-	0
5	-	-	PCB Antenna	N/A	-	0

Note: The EUT has five antennas. There are two antennas for 2.4GHz and three antennas for 5GHz.

For 2.4GHz band:

For 802.11b/g mode:

Only Chain 1 could transmit/receive simultaneously.

For 802.11n mode:

Chain 1 and Chain 2 could transmit/receive simultaneously.

For 5GHz band:

For 802.11a mode:

Only Chain 3(Port1) could transmit/receive simultaneously.

For 802.11n/ac mode:

Chain 3(Port1), Chain 4(Port2) and Chain 5(Port3) could transmit/receive simultaneously.

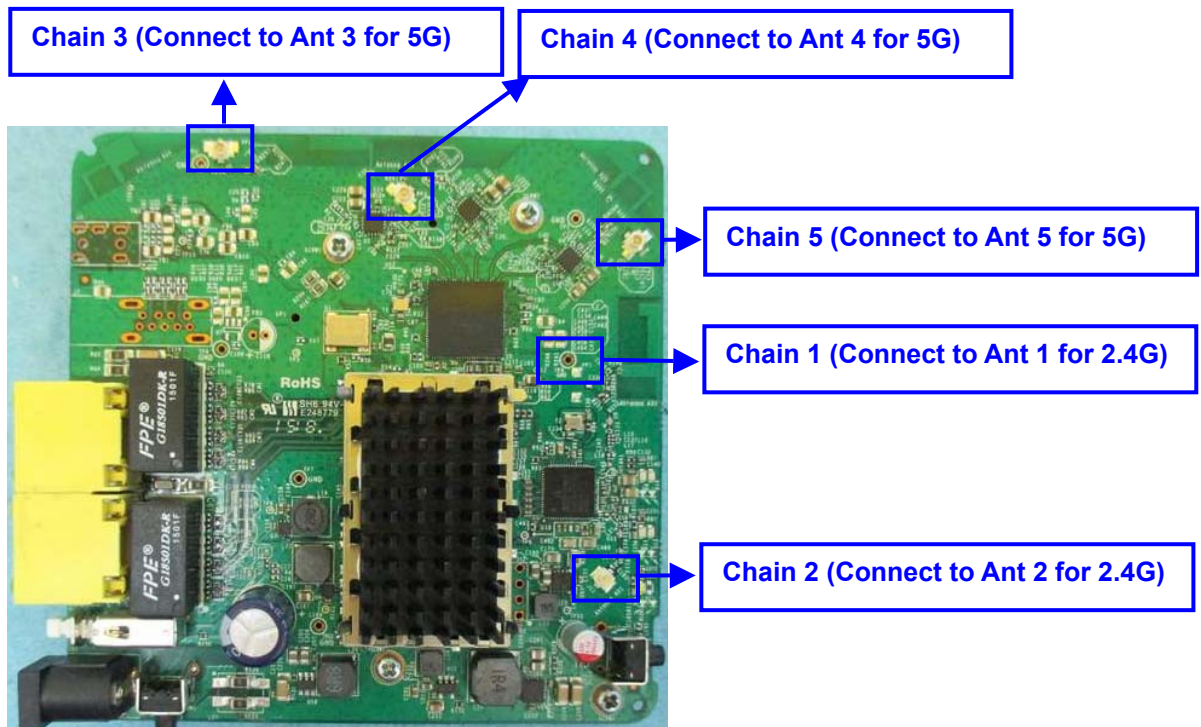



1.1.3 Mode Test Duty Cycle

Mode	DC	T(s)	VBW(Hz) ≥ 1/T
11a	0.98	n/a (DC>=0.98)	n/a (DC>=0.98)
VHT20,BF	0.961	670u	3k
VHT40,BF	0.891	468.75u	3k
VHT80,BF	0.891	231.25u	10k

1.1.4 EUT Operational Condition

EUT Power Type	From Power Adapter		
Beamforming Function	<input checked="" type="checkbox"/> With beamforming for 802.11n/ac in 5GHz.	<input type="checkbox"/>	Without beamforming
Weather Band	<input type="checkbox"/> With 5600~5650MHz	<input checked="" type="checkbox"/>	Without 5600~5650MHz

1.1.5 Table for Class II Change

This product is an extension of original one reported under Sporton project number: FR552501-05.

Below is the table for the change of the product with respect to the original one.

Modifications	Performance Checking
<ol style="list-style-type: none"> 1. Changing Applicant's address to "Mithat Uluunlu Sokak No. 23 Esentepe, Sisli Istanbul 34394 Turkey" from "Gülbahar Mah. Avni Dilligil Sok. Celik Is Merkezi No 5 meciyekoy ISTANBUL, 34394 Turkey". 2. Changing manufacturer to "AirTies Wireless Networks" from "SHENZHEN GONGJIN ELECTRONICS CO.,LTD". 3. Changing manufacturer's address to "Mithat Uluunlu Sokak No. 23 Esentepe, Sisli Istanbul 34394 Turkey" from "2F/3F/4F Baiying Building,1019#Naihaid RD, Nanshan Dist., Shenzhen, Guangdong, CHINA". 	No influence for the original test results.
<ol style="list-style-type: none"> 4. Adding straddle channel. 	<ol style="list-style-type: none"> 1. Emission Bandwidth 2. Maximum Conducted Output Power 3. Peak Power Spectral Density 4. Unwanted Emissions above 1GHz



1.2 Testing Applied Standards

According to the specifications of the manufacturer, the EUT must comply with the requirements of the following standards:

- ◆ 47 CFR FCC Part 15
- ◆ ANSI C63.10-2013
- ◆ FCC KDB 789033 D02 v01r03
- ◆ FCC KDB 644545 D03 v01
- ◆ FCC KDB 662911 D01 v02r01

1.3 Testing Location Information

Testing Location		
<input type="checkbox"/>	HWA YA	ADD : No. 52, Hwa Ya 1st Rd., Kwei-Shan Hsiang, Tao Yuan Hsien, Taiwan, R.O.C. TEL : 886-3-327-3456 FAX : 886-3-318-0055
<input checked="" type="checkbox"/>	JHUBEI	ADD : No.8, Lane 724, Bo-ai St., Jhubei City, HsinChu County 302, Taiwan, R.O.C. TEL : 886-3-656-9065 FAX : 886-3-656-9085

Test Condition	Test Site No.	Test Engineer	Test Environment	Test Date
RF Conducted	TH01-CB	Gino Huang	22°C / 57%	Nov. 25, 2016
Radiated	03CH01-CB	Lucke Hsieh	22°C / 54%	Nov. 24, 2016~ Nov. 25, 2016

Test site Designation No. TW0006 with FCC
Test site registered number IC 4086D with Industry Canada.

1.4 Measurement Uncertainty

ISO/IEC 17025 requires that an estimate of the measurement uncertainties associated with the emissions test results be included in the report. The measurement uncertainties given below are based on a 95% confidence level (based on a coverage factor (k=2))

Test Items	Uncertainty	Remark
Radiated Emission (1GHz ~ 18GHz)	3.7 dB	Confidence levels of 95%
Radiated Emission (18GHz ~ 40GHz)	3.5 dB	Confidence levels of 95%
Conducted Emission	1.7 dB	Confidence levels of 95%



2 Test Configuration of EUT

2.1 Test Channel Mode

Band	Mode	BWch (MHz)	Nss-Min	Nant	Ch. (MHz)	Range	Power Setting
5.6G	11a	20	1	1	5720	C	88
5.8G	11a	20	1	1	5720	C	88
5.6G	VHT20,BF	20	1,(M0)	3	5720	C	76
5.8G	VHT20,BF	20	1,(M0)	3	5720	C	76
5.6G	VHT40,BF	40	1,(M0)	3	5710	C	82
5.8G	VHT40,BF	40	1,(M0)	3	5710	C	82
5.6G	VHT80,BF	80	1,(M0)	3	5690	C	80
5.8G	VHT80,BF	80	1,(M0)	3	5690	C	80

Note:

- ♦ Test range channel consist of L (Low Ch.), M (Middle Ch.), H (High Ch.), S (Single Ch.) and C (Straddle Band Ch.).
- ♦ VHT20/VHT40 covers HT20/HT40, due to same modulation. The power setting for 802.11n HT20 and HT40 are the same or lower than 802.11ac VHT20 and VHT40.
- ♦ There are two modes of EUT, one is beamforming mode, and the other is non-beamforming mode for 802.11n/ac in 5GHz, after evaluating, beamforming mode has been evaluated to be the worst case, so it was selected to test and record in this test report.



2.2 The Worst Case Measurement Configuration

The Worst Case Mode for Following Conformance Tests	
Tests Item	Emission Bandwidth Maximum Conducted Output Power Peak Power Spectral Density
Test Condition	Conducted measurement at transmit chains

The Worst Case Mode for Following Conformance Tests	
Tests Item	Unwanted Emissions
Test Condition	Radiated measurement If EUT consist of multiple antenna assembly (multiple antenna are used in EUT regardless of spatial multiplexing MIMO configuration), the radiated test should be performed with highest antenna gain of each antenna type.
Operating Mode > 1GHz	CTX
1	EUT at Y-axis

The Worst Case Mode for Following Conformance Tests	
Tests Item	Simultaneous Transmission Analysis
Operating Mode	
1	2.4GHz WLAN+5GHz WLAN
Refer to Sporton Test Report No.: FA552501-08 for Co-location RF Exposure Evaluation.	

Note: The EUT can only be used at Y axis position.

2.3 EUT Operation during Test

For CTX Mode:

non-beamforming mode:

The EUT was programmed to be in continuously transmitting mode.

beamforming mode:

For Conducted Mode:

The EUT was programmed to be in continuously transmitting mode.

For Radiated Mode:

During the test, the following programs under WIN XP were executed.

The program was executed as follows:

1. During the test, the EUT operation to normal function.
2. Executed command fixed test channel under Telnet.
3. Executed "Lantest.exe" to link with the remote workstation to transmit and receive packet by WLAN module and transmit duty cycle no less 98%.



2.4 Accessories

Accessories				
No.	Equipment Name	Brand Name	Model Name	Rating
1	Adapter	MOSO	MSA-C1000IC12.0-12W-US	Input: 100-240Vac, 50/60Hz, 0.5A max. Output: 12.0Vdc, 1A

2.5 Support Equipment

For Test Site No: 03CH01-CB
For Non-beamforming Mode

Support Equipment				
No.	Equipment	Brand Name	Model Name	FCC ID
1	Notebook	DELL	E4300	DoC

For Beamforming Mode

Support Equipment				
No.	Equipment	Brand Name	Model Name	FCC ID
1	Notebook	DELL	E4300	DoC
2	WLAN module	Broadcom	BCM943162ZP	QDS-BRCM1075

For Test Site No: TH01-CB

Support Equipment				
No.	Equipment	Brand Name	Model Name	FCC ID
1	Notebook	DELL	E4300	DoC

2.6 Test Setup Diagram

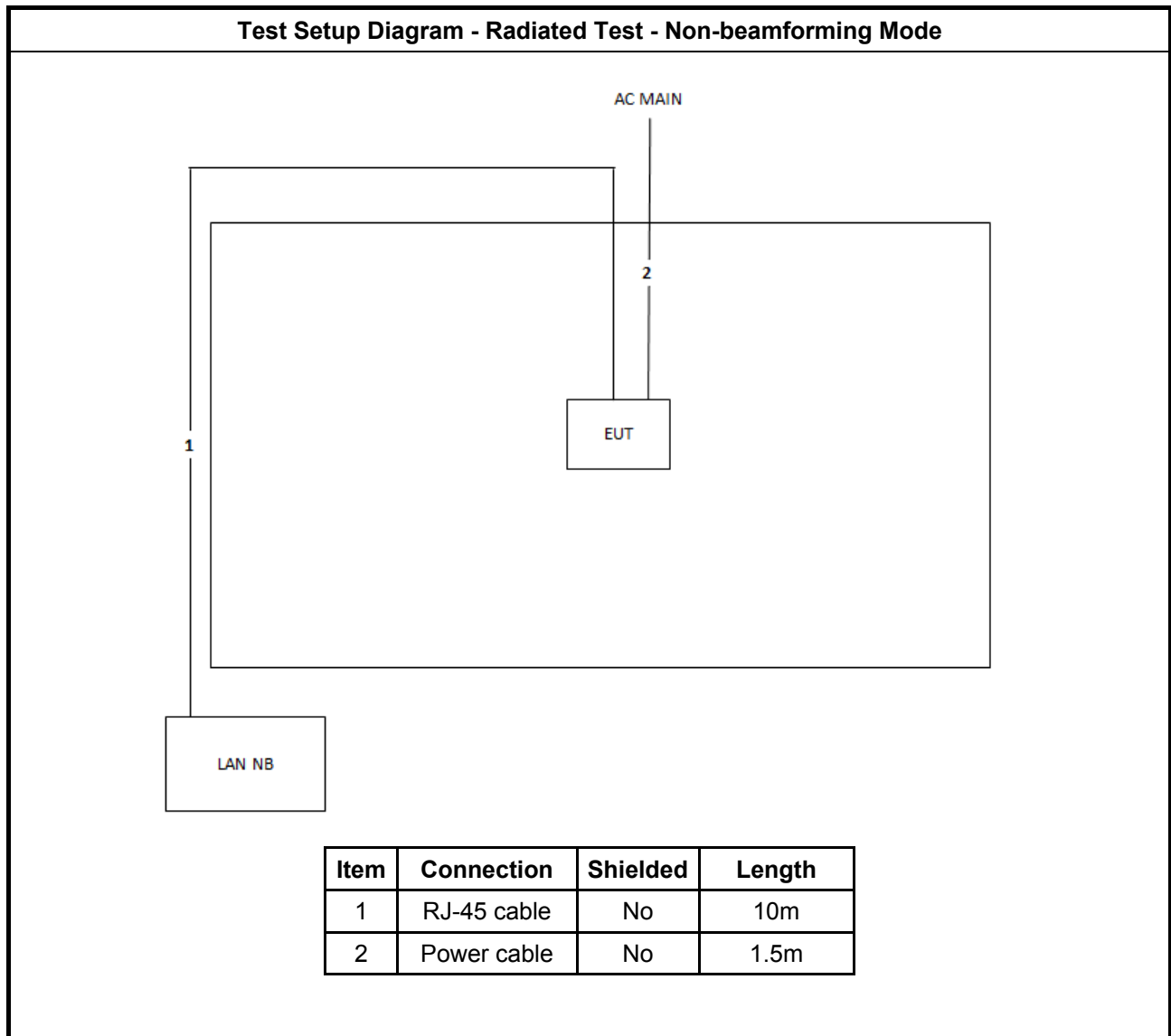

Test Setup Diagram - Radiated Test - Beamforming Mode

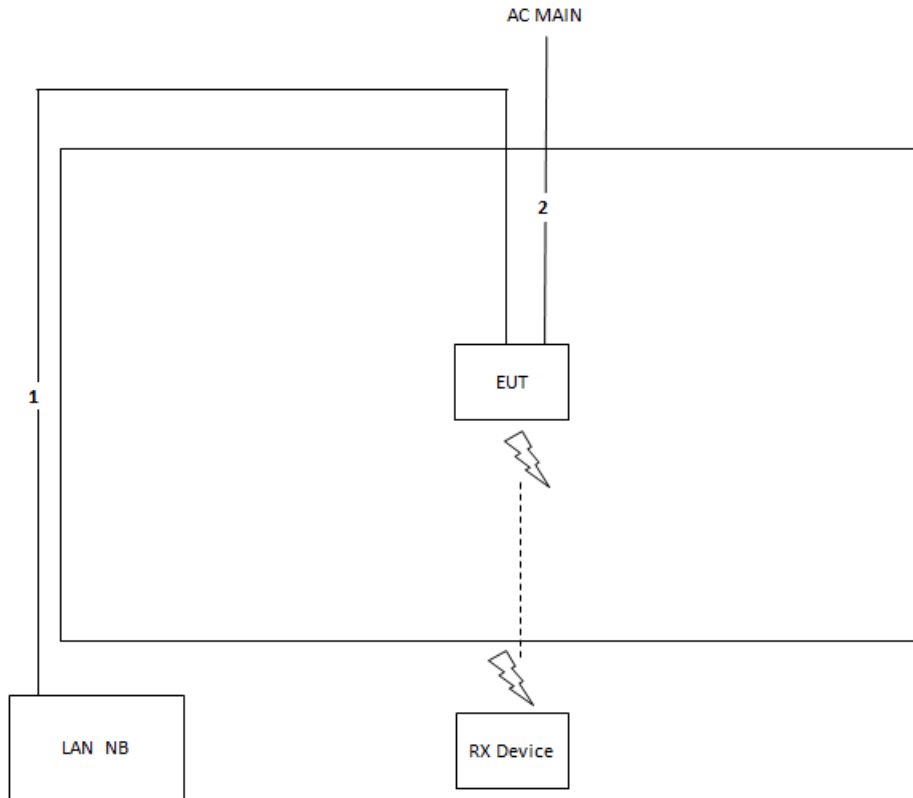

Item	Connection	Shielded	Length
1	RJ-45 cable	No	10m
2	Power cable	No	1.5m

3 Transmitter Test Result

3.1 Emission Bandwidth

3.1.1 Emission Bandwidth Limit

Emission Bandwidth Limit	
UNII Devices	
<input type="checkbox"/>	For the 5.15-5.25 GHz band, N/A
<input type="checkbox"/>	For the 5.25-5.35 GHz band, the maximum conducted output power shall not exceed the lesser of 250 mW or 11 dBm + 10 log B, where B is the 26 dB emission bandwidth in MHz.
<input checked="" type="checkbox"/>	For the 5.47-5.725 GHz band, the maximum conducted output power shall not exceed the lesser of 250 mW or 11 dBm + 10 log B, where B is the 26 dB emission bandwidth in MHz.
<input checked="" type="checkbox"/>	For the 5.725-5.85 GHz band, 6 dB emission bandwidth ≥ 500kHz.
LE-LAN Devices	
<input type="checkbox"/>	For the band 5.15-5.25 GHz, the maximum e.i.r.p. shall not exceed 200 mW or 10 + 10 log B, dBm, whichever power is less. B is the 99% emission bandwidth in MHz.
<input type="checkbox"/>	For the 5.25-5.35 GHz band, the maximum e.i.r.p. shall not exceed 1.0 W or 17 + 10 log B, dBm, whichever power is less. B is the 99% emission bandwidth in MHz
<input type="checkbox"/>	For the 5.47-5.6 GHz band and 5.65-5.725 GHz band, the maximum e.i.r.p. shall not exceed 1.0 W or 17 + 10 log B, dBm, whichever power is less. B is the 99% emission bandwidth in MHz
<input type="checkbox"/>	For the 5.725-5.85 GHz band, 6 dB emission bandwidth ≥ 500kHz.

3.1.2 Measuring Instruments

Refer a test equipment and calibration data table in this test report.

3.1.3 Test Procedures

Test Method	
<ul style="list-style-type: none"> For the emission bandwidth shall be measured using one of the options below: <ul style="list-style-type: none"> <input checked="" type="checkbox"/> Refer as FCC KDB 789033, clause C for EBW and clause D for OBW measurement. <input type="checkbox"/> Refer as ANSI C63.10, clause 6.9.1 for occupied bandwidth testing. <input checked="" type="checkbox"/> Refer as IC RSS-Gen, clause 4.6 for bandwidth testing. 	

3.1.4 Test Setup

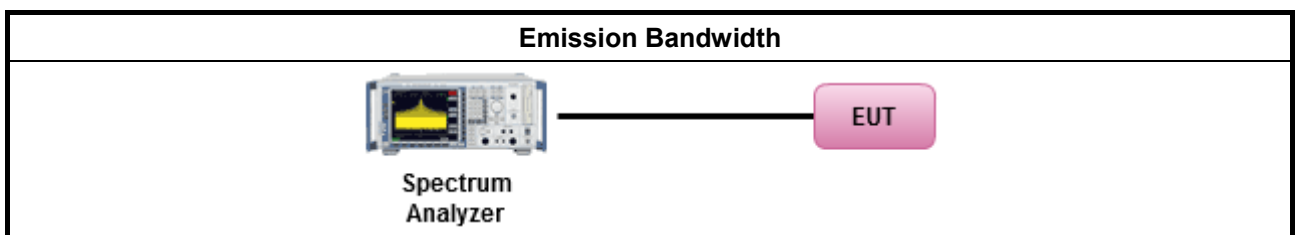

3.1.5 Test Result of Emission Bandwidth

Refer as Appendix A



3.2 Maximum Conducted Output Power

3.2.1 Maximum Conducted Output Power Limit

Maximum Conducted Output Power Limit	
UNII Devices	
<input type="checkbox"/> For the 5.15-5.25 GHz band:	
	<ul style="list-style-type: none"> ▪ Outdoor AP: the maximum conducted output power (P_{Out}) shall not exceed the lesser of 1 W. If $G_{TX} > 6$ dBi, then $P_{Out} = 30 - (G_{TX} - 6)$. e.i.r.p. at any elevation angle above 30 degrees ≤ 125mW [21dBm] ▪ Indoor AP: the maximum conducted output power (P_{Out}) shall not exceed the lesser of 1 W. If $G_{TX} > 6$ dBi, then $P_{Out} = 30 - (G_{TX} - 6)$ ▪ Point-to-point AP: the maximum conducted output power (P_{Out}) shall not exceed the lesser of 1 W. If $G_{TX} > 23$ dBi, then $P_{Out} = 30 - (G_{TX} - 23)$. ▪ Mobile or Portable Client: the maximum conducted output power (P_{Out}) shall not exceed the lesser of 250 mW. If $G_{TX} > 6$ dBi, then $P_{Out} = 24 - (G_{TX} - 6)$.
<input type="checkbox"/> For the 5.25-5.35 GHz band, the maximum conducted output power (P_{Out}) shall not exceed the lesser of 250 mW or 11 dBm + 10 log B, where B is the 26 dB emission bandwidth in MHz. If $G_{TX} > 6$ dBi, then $P_{Out} = 24 - (G_{TX} - 6)$.	
<input checked="" type="checkbox"/> For the 5.47-5.725 GHz band, the maximum conducted output power (P_{Out}) shall not exceed the lesser of 250 mW or 11 dBm + 10 log B, where B is the 26 dB emission bandwidth in MHz. If $G_{TX} > 6$ dBi, then $P_{Out} = 24 - (G_{TX} - 6)$.	
<input checked="" type="checkbox"/> For the 5.725-5.85 GHz band:	
	<ul style="list-style-type: none"> ▪ Point-to-multipoint systems (P2M): the maximum conducted output power (P_{Out}) shall not exceed the lesser of 1 W. If $G_{TX} > 6$ dBi, then $P_{Out} = 30 - (G_{TX} - 6)$. ▪ Point-to-point systems (P2P): the maximum conducted output power (P_{Out}) shall not exceed the lesser of 1 W.
LE-LAN Devices	
<input type="checkbox"/> For the 5.15-5.25 GHz band, the maximum e.i.r.p. shall not exceed 200 mW or 10 + 10 log B, dBm, whichever power is less. B is the 99% emission bandwidth in MHz.	
<input type="checkbox"/> For the 5.25-5.35 GHz band, the maximum e.i.r.p. shall not exceed 1.0 W or 17 + 10 log B, dBm, whichever power is less. B is the 99% emission bandwidth in MHz	
<input type="checkbox"/> For the 5.47-5.6 GHz band and 5.65-5.725 GHz band, the maximum e.i.r.p. shall not exceed 1.0 W or 17 + 10 log B, dBm, whichever power is less. B is the 99% emission bandwidth in MHz	
<input type="checkbox"/> For the 5.725-5.85 GHz band:	
	<ul style="list-style-type: none"> ▪ Point-to-multipoint systems (P2M): the maximum conducted output power (P_{Out}) shall not exceed the lesser of 1 W. If $G_{TX} > 6$ dBi, then $P_{Out} = 30 - (G_{TX} - 6)$. ▪ Point-to-point systems (P2P): the maximum conducted output power (P_{Out}) shall not exceed the lesser of 1 W.
P_{Out} = maximum conducted output power in dBm, G_{TX} = the maximum transmitting antenna directional gain in dBi.	

3.2.2 Measuring Instruments

Refer a test equipment and calibration data table in this test report.

3.2.3 Test Procedures

Test Method	
<ul style="list-style-type: none"> Maximum Conducted Output Power 	
Average over on/off periods with duty factor	
<input checked="" type="checkbox"/>	Refer as FCC KDB 789033, clause E Method SA-2 (spectral trace averaging).
<input type="checkbox"/>	Refer as FCC KDB 789033, clause E Method SA-2 Alt. (RMS detection with slow sweep speed)
Wideband RF power meter and average over on/off periods with duty factor	
<input checked="" type="checkbox"/>	Refer as FCC KDB 789033, clause E Method PM-G (using an RF average power meter).
<ul style="list-style-type: none"> For conducted measurement. 	
<ul style="list-style-type: none"> If the EUT supports multiple transmit chains using options given below: Refer as FCC KDB 662911, In-band power measurements. Using the measure-and-sum approach, measured all transmit ports individually. Sum the power (in linear power units e.g., mW) of all ports for each individual sample and save them. 	
<ul style="list-style-type: none"> If multiple transmit chains, EIRP calculation could be following as methods: $P_{total} = P_1 + P_2 + \dots + P_n$ (calculated in linear unit [mW] and transfer to log unit [dBm]) $EIRP_{total} = P_{total} + DG$ 	

3.2.4 Test Setup

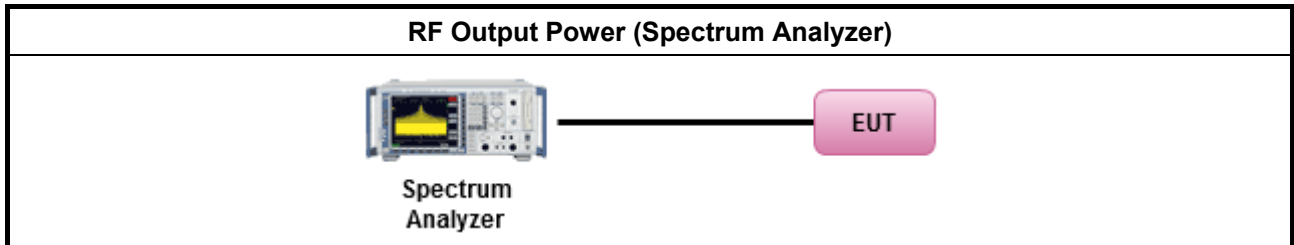

3.2.5 Test Result of Maximum Conducted Output Power

Refer as Appendix B

3.3 Peak Power Spectral Density

3.3.1 Peak Power Spectral Density Limit

Peak Power Spectral Density Limit	
UNII Devices	
<input type="checkbox"/> For the 5.15-5.25 GHz band:	
	<ul style="list-style-type: none"> ▪ Outdoor AP: the peak power spectral density (PPSD) shall not exceed the lesser of 17dBm/MHz. If $G_{TX} > 6$ dBi, then $P_{Out} = 17 - (G_{TX} - 6)$. ▪ Indoor AP: the peak power spectral density (PPSD) shall not exceed the lesser of 17dBm/MHz. If $G_{TX} > 6$ dBi, then $P_{Out} = 17 - (G_{TX} - 6)$. ▪ Point-to-point AP: the peak power spectral density (PPSD) shall not exceed the lesser of 17dBm/MHz. If $G_{TX} > 23$ dBi, then $P_{Out} = 17 - (G_{TX} - 23)$. ▪ Mobile or Portable Client: the peak power spectral density (PPSD) ≤ 11 dBm/MHz. If $G_{TX} > 6$ dBi, then $PPSD = 11 - (G_{TX} - 6)$.
<input type="checkbox"/> For the 5.25-5.35 GHz band, the peak power spectral density (PPSD) ≤ 11 dBm/MHz. If $G_{TX} > 6$ dBi, then $PPSD = 11 - (G_{TX} - 6)$.	
<input checked="" type="checkbox"/> For the 5.47-5.725 GHz band, the peak power spectral density (PPSD) ≤ 11 dBm/MHz. If $G_{TX} > 6$ dBi, then $PPSD = 11 - (G_{TX} - 6)$.	
<input checked="" type="checkbox"/> For the 5.725-5.85 GHz band:	
	<ul style="list-style-type: none"> ▪ Point-to-multipoint systems (P2M): the peak power spectral density (PPSD) ≤ 30 dBm/500kHz. If $G_{TX} > 6$ dBi, then $PPSD = 30 - (G_{TX} - 6)$. ▪ Point-to-point systems (P2P): the peak power spectral density (PPSD) ≤ 30 dBm/500kHz.
LE-LAN Devices	
<input type="checkbox"/> For the 5.15-5.25 GHz band, the peak power spectral density (PPSD) ≤ 4 dBm/MHz and the e.i.r.p. peak power spectral density (PPSD) ≤ 10 dBm/MHz.	
<input type="checkbox"/> For the 5.25-5.35 GHz band, the peak power spectral density (PPSD) ≤ 11 dBm/MHz and the e.i.r.p. peak power spectral density (PPSD) ≤ 17 dBm/MHz.	
	<ul style="list-style-type: none"> ▪ e.i.r.p. greater than 200 mW shall comply with the following e.i.r.p. at different elevations, where θ is the angle above the local horizontal plane (of the Earth) as shown below: -13 dBW/MHz for $0^\circ \leq \theta < 8^\circ$; -13 - 0.716 ($\theta-8$) dBW/MHz for $8^\circ \leq \theta < 40^\circ$ -35.9 - 1.22 ($\theta-40$) dBW/MHz for $40^\circ \leq \theta \leq 45^\circ$; -42 dBW/MHz for $\theta > 45^\circ$
<input type="checkbox"/> For the 5.47-5.6 GHz band and 5.65-5.725 GHz band, the peak power spectral density (PPSD) ≤ 11 dBm/MHz and the e.i.r.p. peak power spectral density (PPSD) ≤ 17 dBm/MHz.	
<input type="checkbox"/> For the 5.725-5.85 GHz band:	
	<ul style="list-style-type: none"> ▪ Point-to-multipoint systems (P2M): the peak power spectral density (PPSD) ≤ 30 dBm/500kHz. If $G_{TX} > 6$ dBi, then $PPSD = 30 - (G_{TX} - 6)$. ▪ Point-to-point systems (P2P): the peak power spectral density (PPSD) ≤ 30 dBm/500kHz.
<p>PPSD = peak power spectral density that he same method as used to determine the conducted output power shall be used to determine the power spectral density. And power spectral density in dBm/MHz G_{TX} = the maximum transmitting antenna directional gain in dBi.</p>	

3.3.2 Measuring Instruments

Refer a test equipment and calibration data table in this test report.

3.3.3 Test Procedures

Test Method	
<ul style="list-style-type: none"> ▪ Peak power spectral density procedures that the same method as used to determine the conducted output power shall be used to determine the peak power spectral density and use the peak search function on the spectrum analyzer to find the peak of the spectrum. For the peak power spectral density shall be measured using below options: 	
<input type="checkbox"/>	Refer as FCC KDB 789033, F5) power spectral density can be measured using resolution bandwidths < 1 MHz provided that the results are integrated over 1 MHz bandwidth
[duty cycle ≥ 98% or external video / power trigger]	
<input checked="" type="checkbox"/>	Refer as FCC KDB 789033, clause E Method SA-1 (spectral trace averaging).
<input type="checkbox"/>	Refer as FCC KDB 789033, clause E Method SA-1 Alt. (RMS detection with slow sweep speed)
duty cycle < 98% and average over on/off periods with duty factor	
<input checked="" type="checkbox"/>	Refer as FCC KDB 789033, clause E Method SA-2 (spectral trace averaging).
<input type="checkbox"/>	Refer as FCC KDB 789033, clause E Method SA-2 Alt. (RMS detection with slow sweep speed)
<ul style="list-style-type: none"> ▪ For conducted measurement. 	
<ul style="list-style-type: none"> ▪ If the EUT supports multiple transmit chains using options given below: 	
<input checked="" type="checkbox"/>	Option 1: Measure and sum the spectra across the outputs. Refer as FCC KDB 662911, In-band power spectral density (PSD). Sample all transmit ports simultaneously using a spectrum analyzer for each transmit port. Where the trace bin-by-bin of each transmit port summing can be performed. (i.e., in the first spectral bin of output 1 is summed with that in the first spectral bin of output 2 and that from the first spectral bin of output 3, and so on up to the NTX output to obtain the value for the first frequency bin of the summed spectrum.). Add up the amplitude (power) values for the different transmit chains and use this as the new data trace.
<input type="checkbox"/>	Option 2: Measure and sum spectral maxima across the outputs. With this technique, spectra are measured at each output of the device at the required resolution bandwidth. The maximum value (peak) of each spectrum is determined. These maximum values are then summed mathematically in linear power units across the outputs. These operations shall be performed separately over frequency spans that have different out-of-band or spurious emission limits,
<input type="checkbox"/>	Option 3: Measure and add 10 log(N) dB, where N is the number of transmit chains. Refer as FCC KDB 662911, In-band power spectral density (PSD). Performed at each transmit chains and each transmit chains shall be compared with the limit have been reduced with 10 log(N). Or each transmit chains shall be add 10 log(N) to compared with the limit.
<ul style="list-style-type: none"> ▪ If multiple transmit chains, EIRP PPSD calculation could be following as methods: $PPSD_{total} = PPSD_1 + PPSD_2 + \dots + PPSD_n$ (calculated in linear unit [mW] and transfer to log unit [dBm]) $EIRP_{total} = PPSD_{total} + DG$ 	

3.3.4 Test Setup

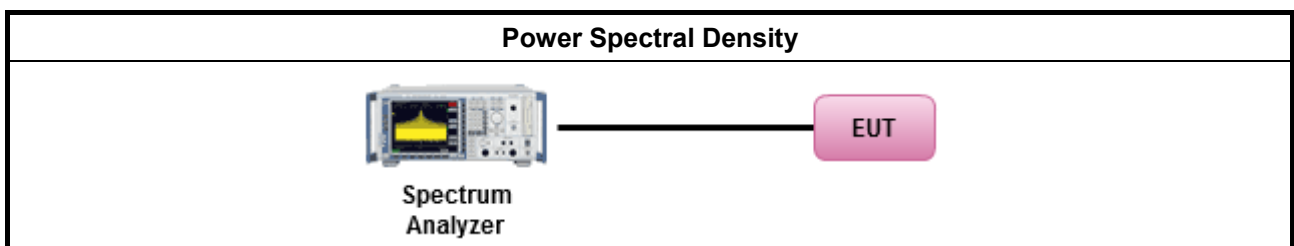



3.3.5 Test Result of Peak Power Spectral Density

Refer as Appendix C



3.4 Unwanted Emissions

3.4.1 Transmitter Radiated Unwanted Emissions Limit

Unwanted emissions below 1 GHz and restricted band emissions above 1GHz limit			
Frequency Range (MHz)	Field Strength (uV/m)	Field Strength (dBuV/m)	Measure Distance (m)
0.009~0.490	2400/F(kHz)	48.5 - 13.8	300
0.490~1.705	24000/F(kHz)	33.8 - 23	30
1.705~30.0	30	29	30
30~88	100	40	3
88~216	150	43.5	3
216~960	200	46	3
Above 960	500	54	3

Note 1: Test distance for frequencies at or above 30 MHz, measurements may be performed at a distance other than the limit distance provided they are not performed in the near field and the emissions to be measured can be detected by the measurement equipment. When performing measurements at a distance other than that specified, the results shall be extrapolated to the specified distance using an extrapolation factor of 20 dB/decade (inverse of linear distance for field-strength measurements, inverse of linear distance-squared for power-density measurements).

Note 2: Test distance for frequencies at below 30 MHz, measurements may be performed at a distance closer than the EUT limit distance; however, an attempt should be made to avoid making measurements in the near field. When performing measurements below 30 MHz at a closer distance than the limit distance, the results shall be extrapolated to the specified distance by either making measurements at a minimum of two or more distances on at least one radial to determine the proper extrapolation factor or by using the square of an inverse linear distance extrapolation factor (40 dB/decade). The test report shall specify the extrapolation method used to determine compliance of the EUT.

Un-restricted band emissions above 1GHz Limit	
Operating Band	Limit
5.47 - 5.725 GHz	e.i.r.p. -27 dBm [68.2 dBuV/m@3m]
5.725 - 5.85 GHz	all emissions shall be limited to a level of -27 dBm/MHz at 75 MHz or more above or below the band edge increasing linearly to 10 dBm/MHz at 25 MHz above or below the band edge, and from 25 MHz above or below the band edge increasing linearly to a level of 15.6 dBm/MHz at 5 MHz above or below the band edge, and from 5 MHz above or below the band edge increasing linearly to a level of 27 dBm/MHz at the band edge.

Note 1: Measurements may be performed at a distance other than the limit distance provided they are not performed in the near field and the emissions to be measured can be detected by the measurement equipment. When performing measurements at a distance other than that specified, the results shall be extrapolated to the specified distance using an extrapolation factor of 20 dB/decade (inverse of linear distance for field-strength measurements, inverse of linear distance-squared for power-density measurements).



3.4.2 Measuring Instruments

Refer a test equipment and calibration data table in this test report.

3.4.3 Test Procedures

Test Method	
	<ul style="list-style-type: none"> ▪ Measurements may be performed at a distance other than the limit distance provided they are not performed in the near field and the emissions to be measured can be detected by the measurement equipment. Measurements shall not be performed at a distance greater than 30 m for frequencies above 30 MHz, unless it can be further demonstrated that measurements at a distance of 30 m or less are impractical. When performing measurements at a distance other than that specified, the results shall be extrapolated to the specified distance using an extrapolation factor of 20 dB/decade (inverse of linear distance for field-strength measurements, inverse of linear distance-squared for power-density measurements).
	<ul style="list-style-type: none"> ▪ The average emission levels shall be measured in [duty cycle \geq 98 or duty factor].
	<ul style="list-style-type: none"> ▪ For the transmitter unwanted emissions shall be measured using following options below: <ul style="list-style-type: none"> ▪ Refer as FCC KDB 789033, clause H)2) for unwanted emissions into non-restricted bands. ▪ Refer as FCC KDB 789033, clause H)1) for unwanted emissions into restricted bands. <ul style="list-style-type: none"> <input type="checkbox"/> Refer as FCC KDB 789033, H)6) Method AD (Trace Averaging). <input checked="" type="checkbox"/> Refer as FCC KDB 789033, H)6) Method VB (Reduced VBW). <input type="checkbox"/> Refer as ANSI C63.10, clause 4.2.3.2.3 (Reduced VBW). VBW \geq 1/T, where T is pulse time. <input type="checkbox"/> Refer as ANSI C63.10, clause 4.2.3.2.4 average value of pulsed emissions. <input checked="" type="checkbox"/> Refer as FCC KDB 789033, clause H)5) measurement procedure peak limit. <input type="checkbox"/> Refer as ANSI C63.10, clause 4.2.3.2.2 measurement procedure peak limit.
	<ul style="list-style-type: none"> ▪ For radiated measurement. <ul style="list-style-type: none"> ▪ Refer as ANSI C63.10, clause 6.4 for radiated emissions below 30 MHz and test distance is 3m. ▪ Refer as ANSI C63.10, clause 6.5 for radiated emissions 30 MHz to 1 GHz and test distance is 3m. ▪ Refer as ANSI C63.10, clause 6.6 for radiated emissions above 1GHz.
	<ul style="list-style-type: none"> ▪ The any unwanted emissions level shall not exceed the fundamental emission level.
	<ul style="list-style-type: none"> ▪ All amplitude of spurious emissions that are attenuated by more than 20 dB below the permissible value has no need to be reported.

3.4.4 Test Setup

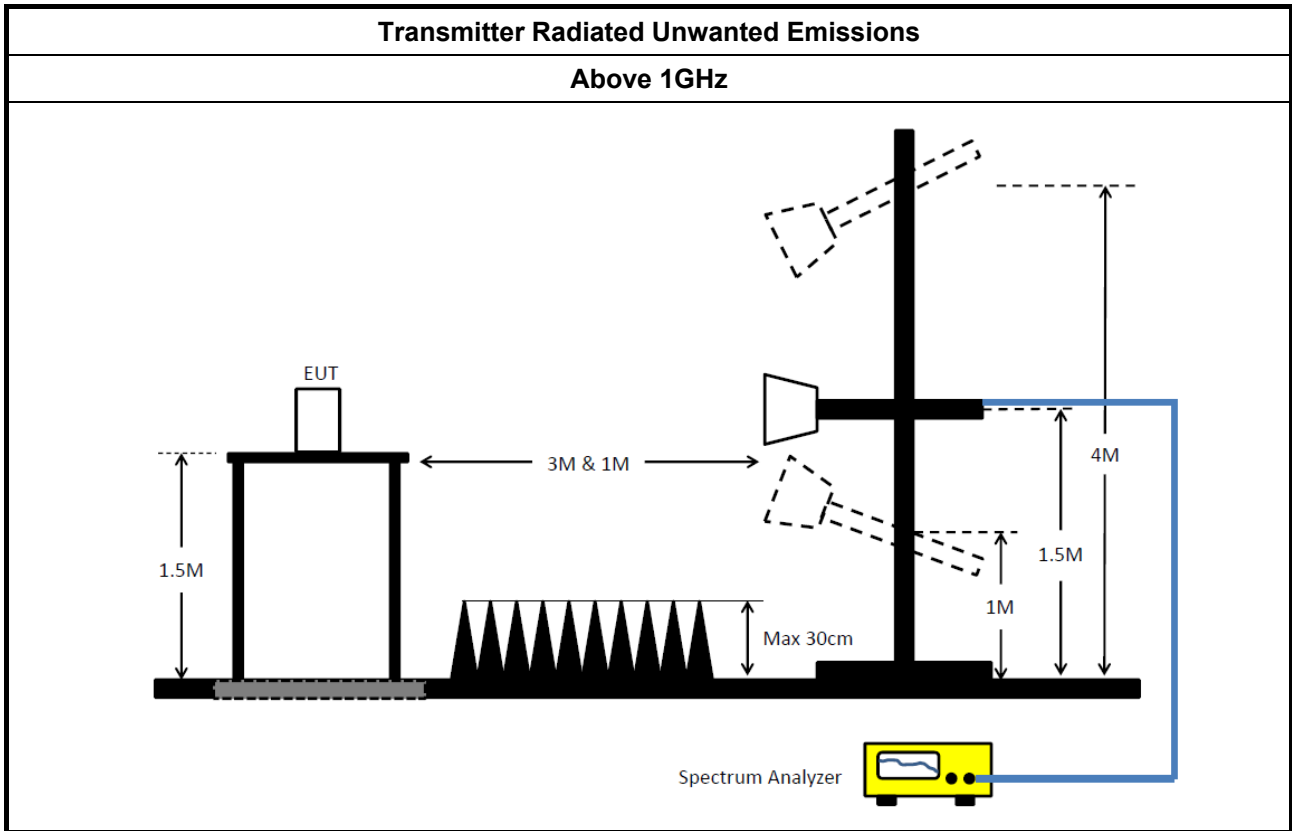

3.4.5 Test Result of Transmitter Unwanted Emissions

Refer as Appendix D



4 Test Equipment and Calibration Data

Instrument	Manufacturer	Model No.	Serial No.	Characteristics	Calibration Date	Remark
Horn Antenna	EMCO	3115	00075790	750MHz ~ 18GHz	Nov. 10, 2016	Radiation (03CH01-CB)
Horn Antenna	Schwarzbeck	BBHA 9170	BBHA9170252	15GHz ~ 40GHz	Jul. 25, 2016	Radiation (03CH01-CB)
Pre-Amplifier	Agilent	8449B	3008A02310	1GHz ~ 26.5GHz	Jan. 18, 2016	Radiation (03CH01-CB)
Pre-Amplifier	MITEQ	TTA1840-35-HG	1864479	18GHz ~ 40GHz	Jun. 28, 2016	Radiation (03CH01-CB)
Spectrum Analyzer	R&S	FSP40	100056	9kHz ~ 40GHz	Nov. 21, 2016	Radiation (03CH01-CB)
RF Cable-high	Woken	High Cable-16	N/A	1 GHz ~ 18 GHz	Oct. 24, 2016	Radiation (03CH01-CB)
RF Cable-high	Woken	High Cable-17	N/A	1 GHz ~ 18 GHz	Oct. 24, 2016	Radiation (03CH01-CB)
RF Cable-high	Woken	High Cable-40G-1	N/A	18GHz ~ 40 GHz	Oct. 24, 2016	Radiation (03CH01-CB)
RF Cable-high	Woken	High Cable-40G-2	N/A	18GHz ~ 40 GHz	Oct. 24, 2016	Radiation (03CH01-CB)
Test Software	Audix	E3	6.2009-10-7	N/A	N/A	Radiation (03CH01-CB)
Spectrum analyzer	R&S	FSV40	100979	9kHz~40GHz	Dec. 09, 2015	Conducted (TH01-CB)
RF Cable-high	Woken	RG402	High Cable-6	1 GHz – 26.5 GHz	Oct. 24, 2016	Conducted (TH01-CB)
RF Cable-high	Woken	RG402	High Cable-7	1 GHz – 26.5 GHz	Oct. 24, 2016	Conducted (TH01-CB)
RF Cable-high	Woken	RG402	High Cable-8	1 GHz – 26.5 GHz	Oct. 24, 2016	Conducted (TH01-CB)
RF Cable-high	Woken	RG402	High Cable-9	1 GHz – 26.5 GHz	Oct. 24, 2016	Conducted (TH01-CB)
RF Cable-high	Woken	RG402	High Cable-10	1 GHz – 26.5 GHz	Oct. 24, 2016	Conducted (TH01-CB)
Power Sensor	Agilent	U2021XA	MY54320014	50MHz~18GHz	Apr. 20, 2016	Conducted (TH01-CB)

Note: Calibration Interval of instruments listed above is one year.



Summary

Mode	Max-N dB (Hz)	Max-OBW (Hz)	ITU-Code	Min-N dB (Hz)	Min-OBW (Hz)
5.6G;11a;Nss1;Ntx1	25.905M	16.957M	17MOD1D	25.905M	16.957M
5.8G;11a;Nss1;Ntx1	3.14M	12.594M	12M6D1D	3.14M	12.594M
5.6G;VHT20,BF;Nss1,(M0);Ntx3	17.535M	13.868M	13M9D1D	15.045M	13.853M
5.8G;VHT20,BF;Nss1,(M0);Ntx3	3.84M	4.558M	4M56D1D	3.76M	4.118M
5.6G;VHT40,BF;Nss1,(M0);Ntx3	43.995M	33.128M	33M1D1D	41.335M	33.023M
5.8G;VHT40,BF;Nss1,(M0);Ntx3	3.2M	16.672M	16M7D1D	3.16M	10.455M
5.6G;VHT80,BF;Nss1,(M0);Ntx3	93.3M	72.639M	72M6D1D	92.625M	72.489M
5.8G;VHT80,BF;Nss1,(M0);Ntx3	3.12M	29.945M	29M9D1D	3.1M	22.169M



Result

Mode	Result	Limit (Hz)	P1-N dB (Hz)	P1-OBW (Hz)	P2-N dB (Hz)	P2-OBW (Hz)	P3-N dB (Hz)	P3-OBW (Hz)
5.6G;11a;Nss1;Ntx1;5720	Pass	Inf	25.905M	16.957M				
5.8G;11a;Nss1;Ntx1;5720	Pass	500k	3.14M	12.594M				
5.6G;VHT20,BF;Nss1,(M0);Ntx3;5720	Pass	Inf	17.475M	13.868M	17.535M	13.853M	15.045M	13.853M
5.8G;VHT20,BF;Nss1,(M0);Ntx3;5720	Pass	500k	3.84M	4.558M	3.76M	4.318M	3.78M	4.118M
5.6G;VHT40,BF;Nss1,(M0);Ntx3;5710	Pass	Inf	42.14M	33.023M	43.995M	33.128M	41.335M	33.023M
5.8G;VHT40,BF;Nss1,(M0);Ntx3;5710	Pass	500k	3.2M	16.672M	3.16M	16.632M	3.18M	10.455M
5.6G;VHT80,BF;Nss1,(M0);Ntx3;5690	Pass	Inf	93.3M	72.639M	92.925M	72.489M	92.625M	72.489M
5.8G;VHT80,BF;Nss1,(M0);Ntx3;5690	Pass	500k	3.12M	28.466M	3.12M	29.945M	3.1M	22.169M

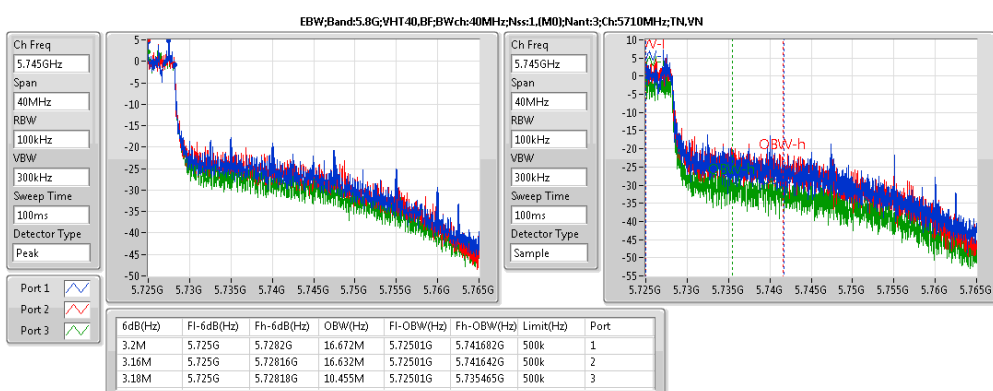
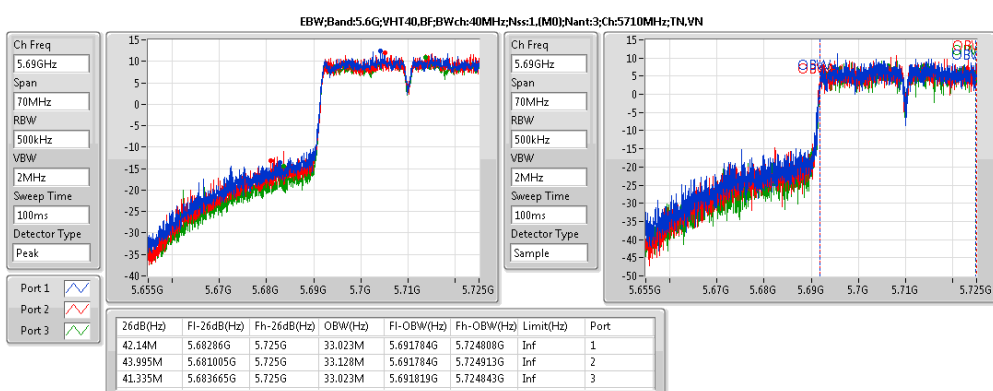
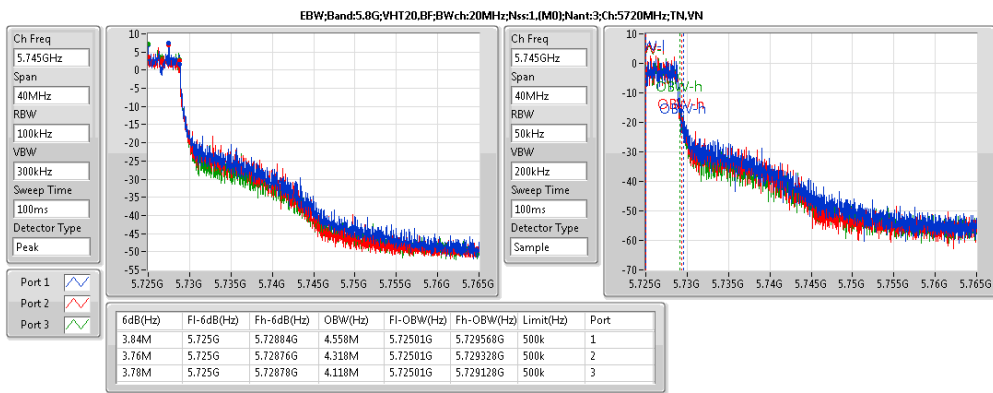
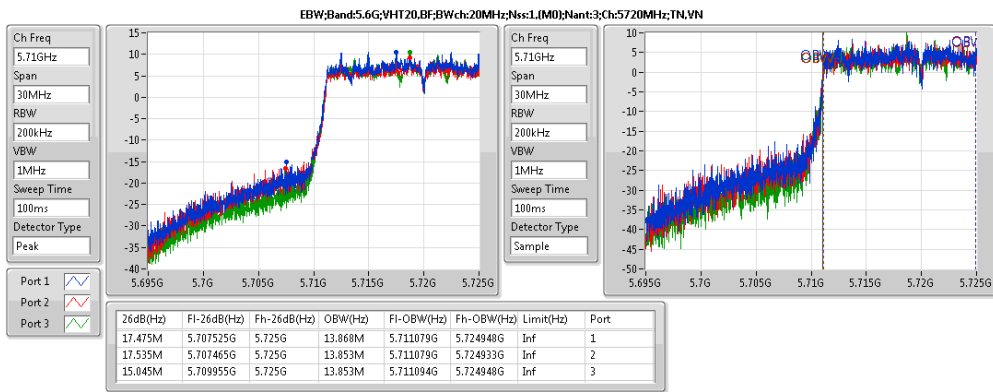
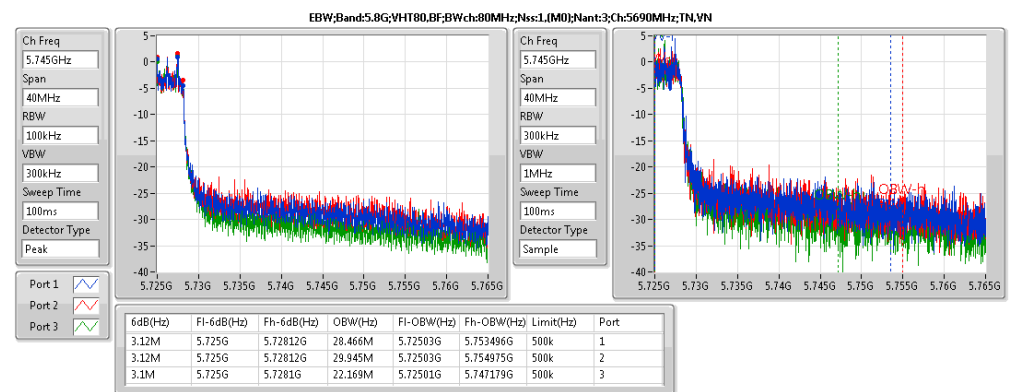
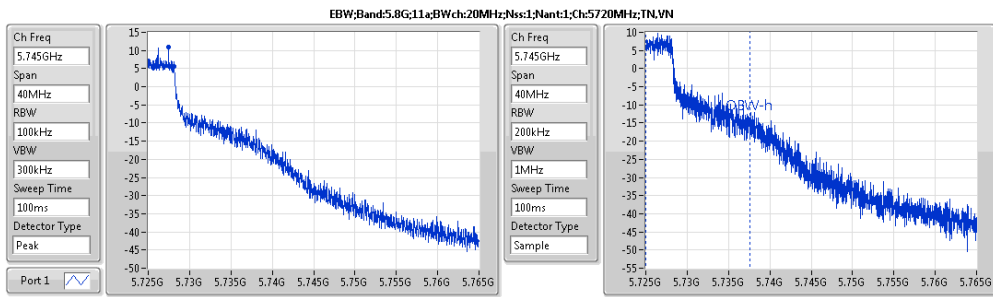
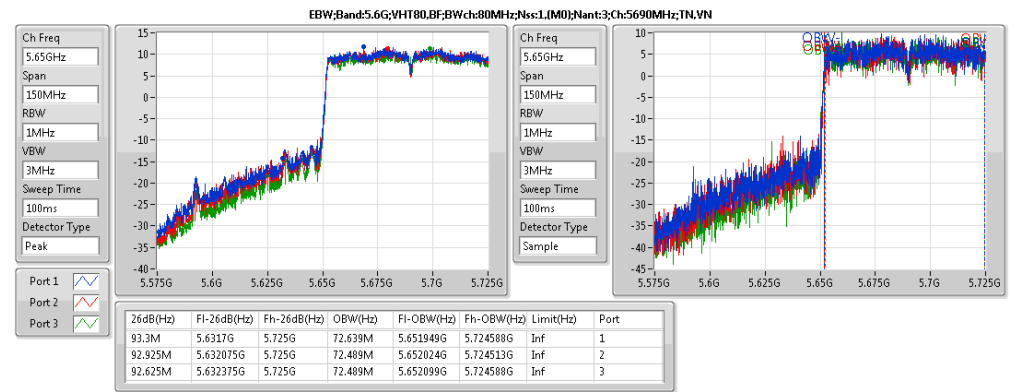
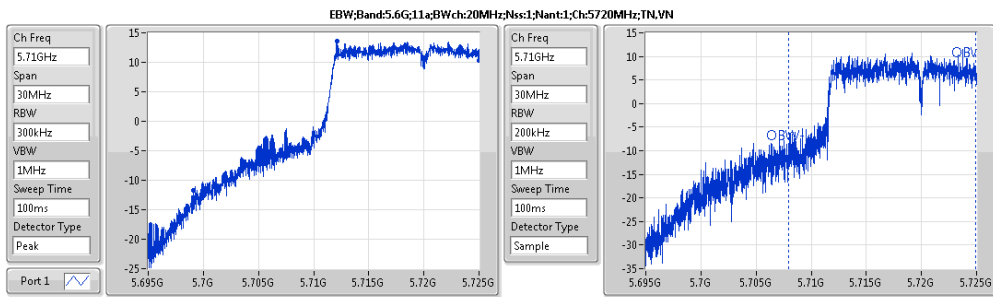



Summary

Mode	Sum (dBm)	Sum (W)	EIRP (dBm)	EIRP (W)
5.6G;11a;Nss1;Ntx1	21.45	0.13964	21.45	0.13964
5.8G;11a;Nss1;Ntx1	15.34	0.0342	15.34	0.0342
5.6G;VHT20,BF;Nss1,(M0);Ntx3	22.61	0.18239	27.38	0.54702
5.8G;VHT20,BF;Nss1,(M0);Ntx3	16.71	0.04688	21.48	0.1406
5.6G;VHT40,BF;Nss1,(M0);Ntx3	23.80	0.23988	28.57	0.71945
5.8G;VHT40,BF;Nss1,(M0);Ntx3	13.43	0.02203	18.20	0.06607
5.6G;VHT80,BF;Nss1,(M0);Ntx3	23.73	0.23605	28.50	0.70795
5.8G;VHT80,BF;Nss1,(M0);Ntx3	9.58	0.00908	14.35	0.02723



Result

Mode	Result	DG (dBi)	Sum (dBm)	Sum Lim. (dBm)	EIRP (dBm)	EIRP Lim. (dBm)	P1 (dBm)	P2 (dBm)	P3 (dBm)
5.6G;11a;Nss1;Ntx1;5720	Pass	0.00	21.45	23.98	21.45	30.00	21.45		
5.8G;11a;Nss1;Ntx1;5720	Pass	0.00	15.34	30.00	15.34	36.00	15.34		
5.6G;VHT20,BF;Nss1,(M0);Ntx3;5720	Pass	4.77	22.61	22.77	27.38	28.77	18.17	17.93	17.38
5.8G;VHT20,BF;Nss1,(M0);Ntx3;5720	Pass	4.77	16.71	30.00	21.48	36.00	11.96	11.90	11.95
5.6G;VHT40,BF;Nss1,(M0);Ntx3;5710	Pass	4.77	23.80	23.98	28.57	30.00	19.25	19.16	18.66
5.8G;VHT40,BF;Nss1,(M0);Ntx3;5710	Pass	4.77	13.43	30.00	18.20	36.00	8.58	8.79	8.60
5.6G;VHT80,BF;Nss1,(M0);Ntx3;5690	Pass	4.77	23.73	23.98	28.50	30.00	19.25	18.96	18.66
5.8G;VHT80,BF;Nss1,(M0);Ntx3;5690	Pass	4.77	9.58	30.00	14.35	36.00	4.81	4.95	4.65

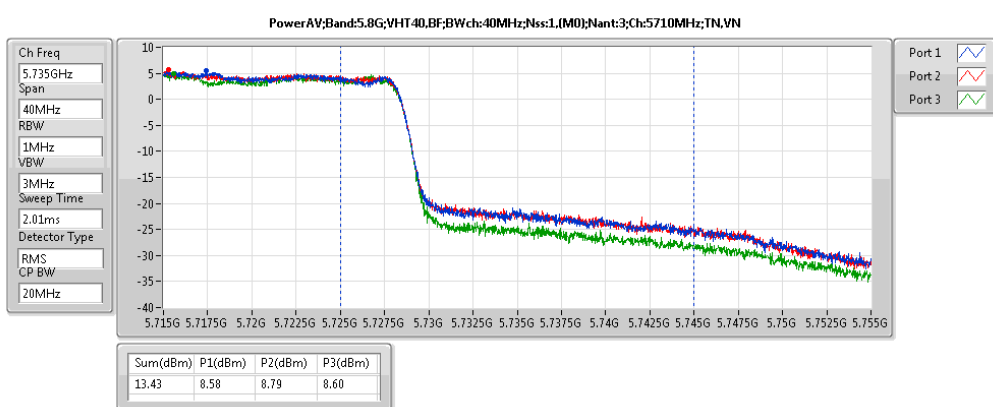
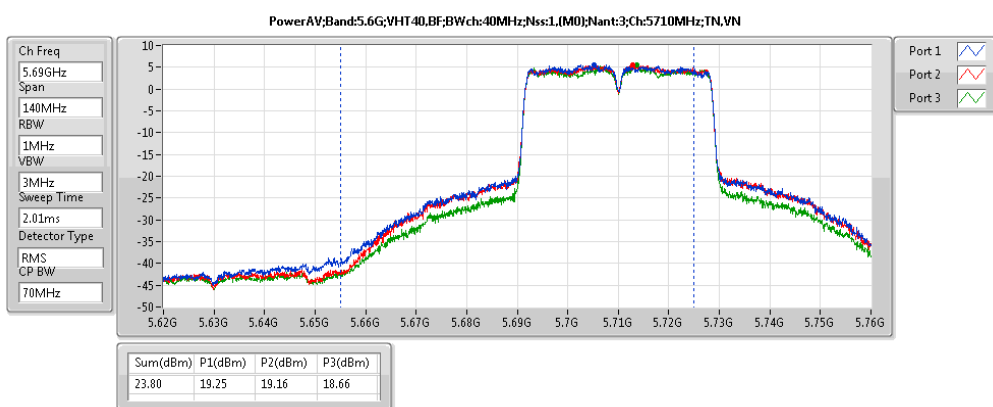
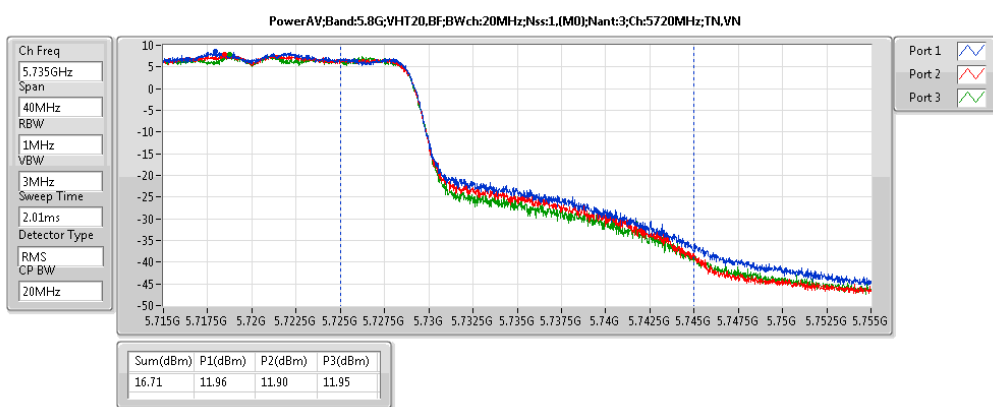
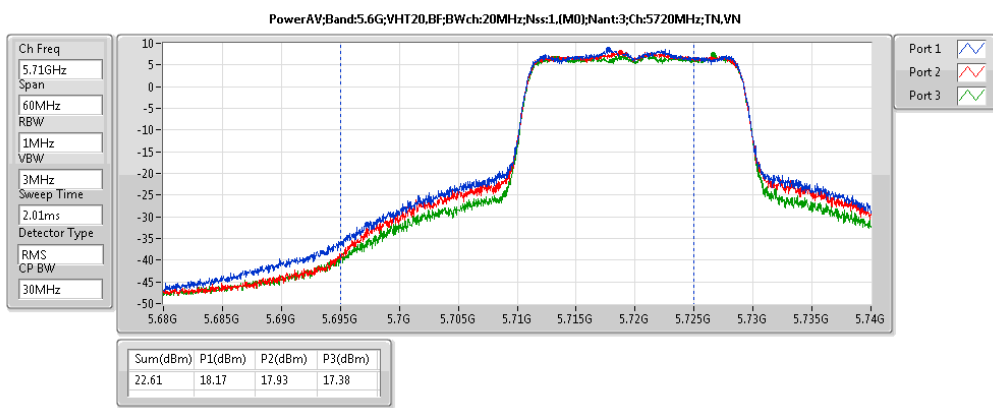
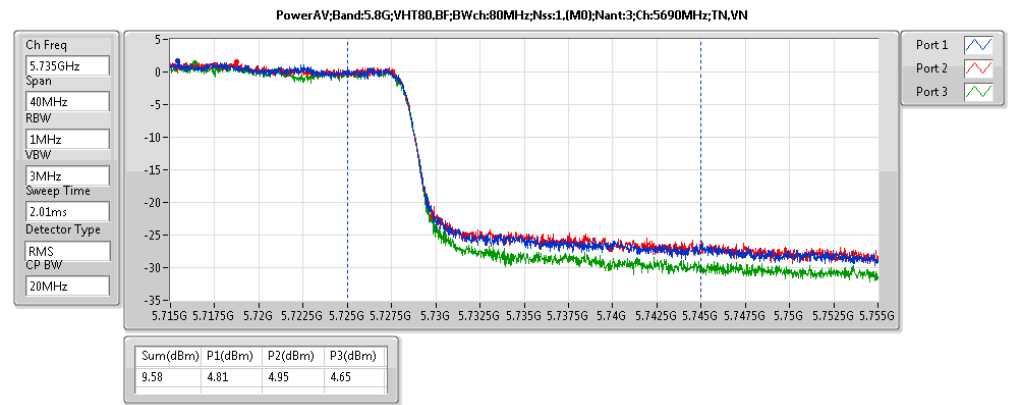
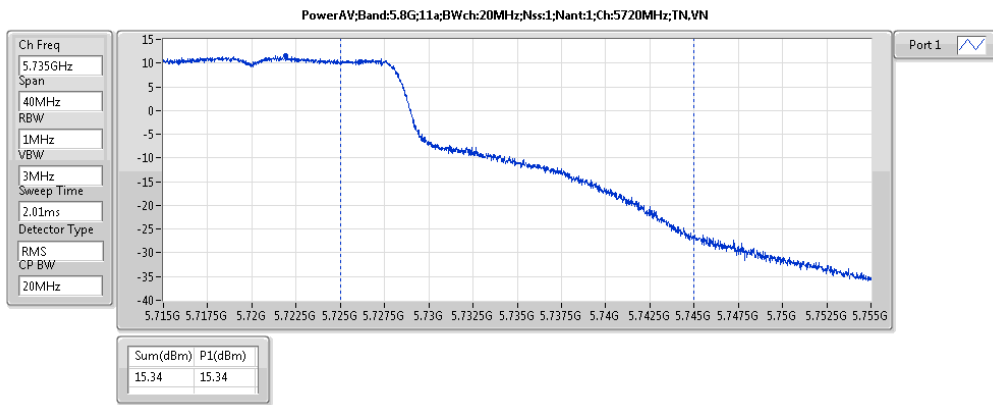
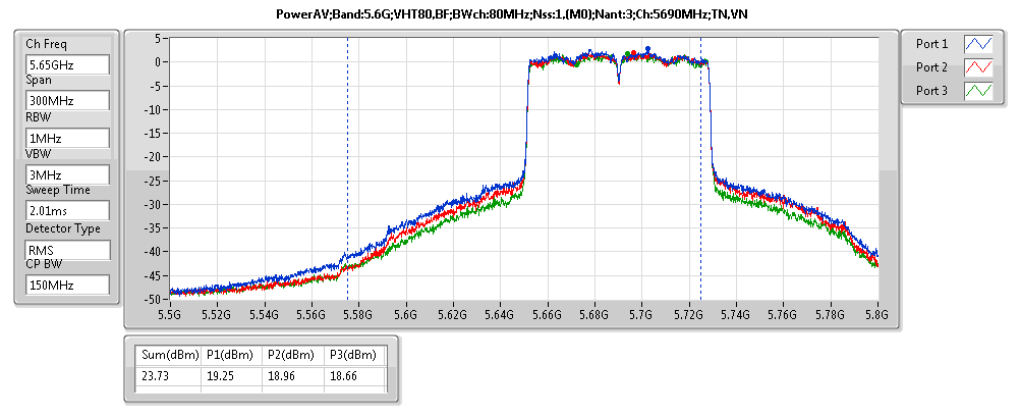
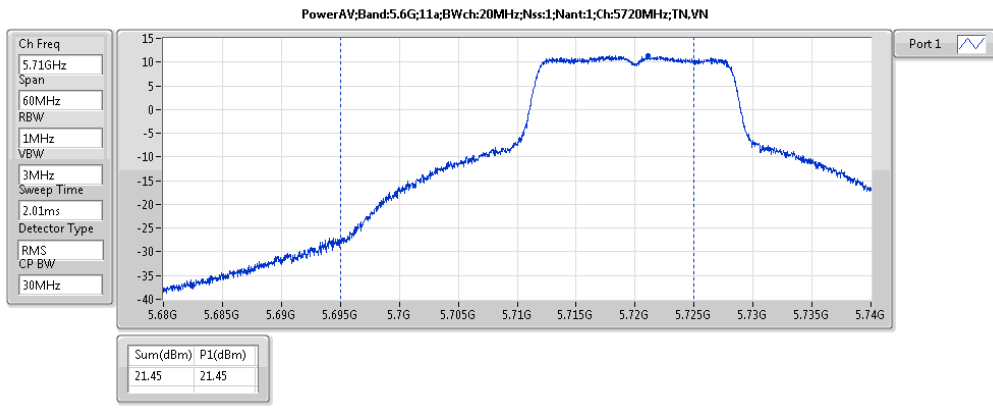



Summary

Mode	PD (dBm/RBW)	EIRP.PD (dBm/RBW)
5.6G;11a;Nss1;Ntx1	9.88	9.88
5.8G;11a;Nss1;Ntx1	7.90	7.90
5.6G;VHT20,BF;Nss1,(M0);Ntx3	10.99	15.76
5.8G;VHT20,BF;Nss1,(M0);Ntx3	8.61	13.39
5.6G;VHT40,BF;Nss1,(M0);Ntx3	8.52	13.29
5.8G;VHT40,BF;Nss1,(M0);Ntx3	6.07	10.84
5.6G;VHT80,BF;Nss1,(M0);Ntx3	5.13	9.90
5.8G;VHT80,BF;Nss1,(M0);Ntx3	2.37	7.14

Result

Mode	Result	Meas.RBW (Hz)	Lim.RBW (Hz)	BWCF (dB)	DG (dBi)	PD (dBm/RBW)	PD.Limit (dBm/RBW)	EIRP.PD (dBm/RBW)	EIRP.PD.Lim (dBm/RBW)	P1 (dBm/RBW)	P2 (dBm/RBW)	P3 (dBm/RBW)
5.6G;11a;Nss1;Ntx1;5720	Pass	1M	1M	0.00	0.00	9.88	11.00	9.88	Inf	9.88		
5.8G;11a;Nss1;Ntx1;5720	Pass	500k	500k	0.00	0.00	7.90	30.00	7.90	Inf	7.90		
5.6G;VHT20,BF;Nss1,(M0);Ntx3;5720	Pass	1M	1M	0.00	4.77	10.99	11.00	15.76	Inf	6.99	6.65	6.03
5.8G;VHT20,BF;Nss1,(M0);Ntx3;5720	Pass	500k	500k	0.00	4.77	8.61	30.00	13.39	Inf	4.17	3.94	4.81
5.6G;VHT40,BF;Nss1,(M0);Ntx3;5710	Pass	1M	1M	0.00	4.77	8.52	11.00	13.29	Inf	4.17	4.18	3.97
5.8G;VHT40,BF;Nss1,(M0);Ntx3;5710	Pass	500k	500k	0.00	4.77	6.07	30.00	10.84	Inf	1.83	1.73	1.50
5.6G;VHT80,BF;Nss1,(M0);Ntx3;5690	Pass	1M	1M	0.00	4.77	5.13	11.00	9.90	Inf	1.21	0.93	0.20
5.8G;VHT80,BF;Nss1,(M0);Ntx3;5690	Pass	500k	500k	0.00	4.77	2.37	30.00	7.14	Inf	-2.00	-1.91	-2.34

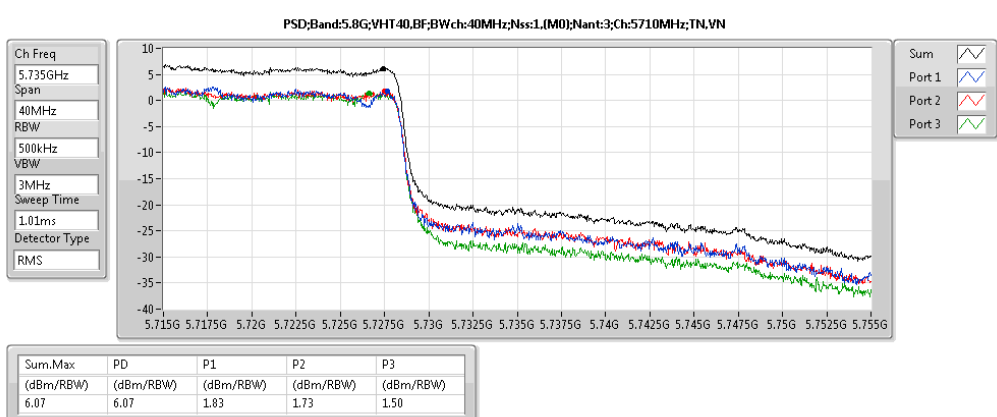
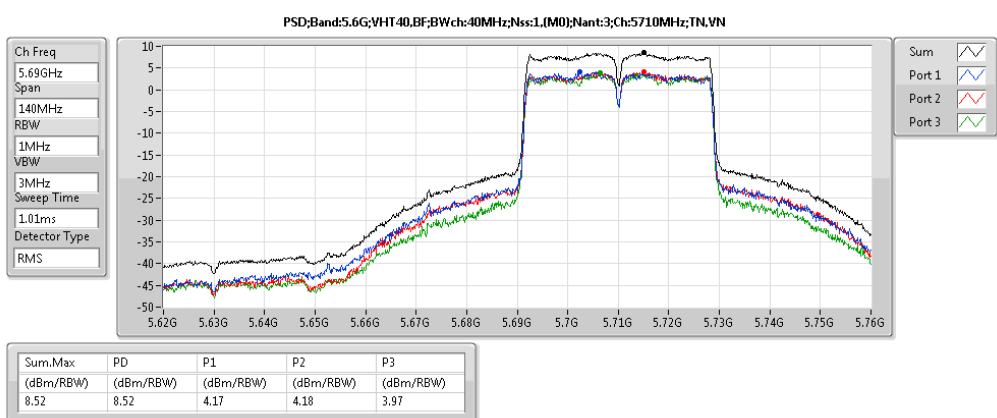
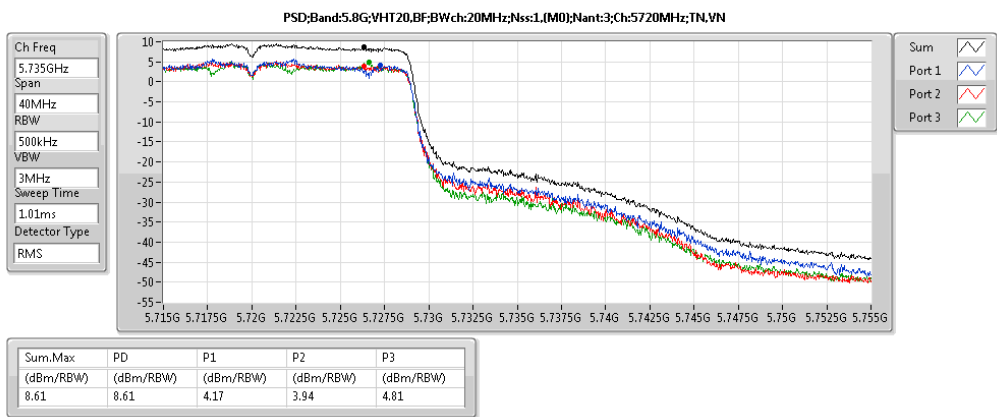
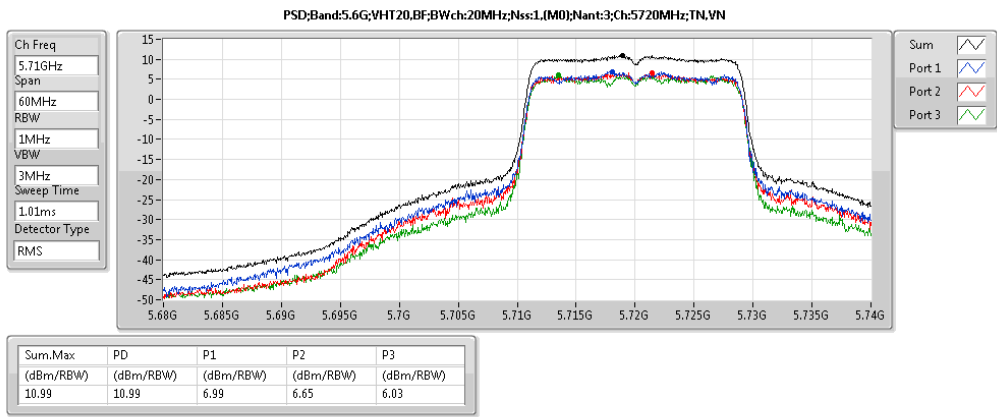
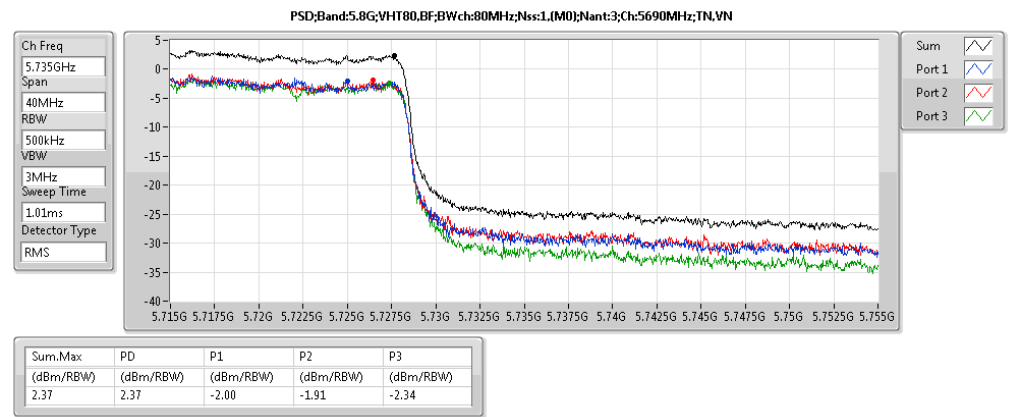
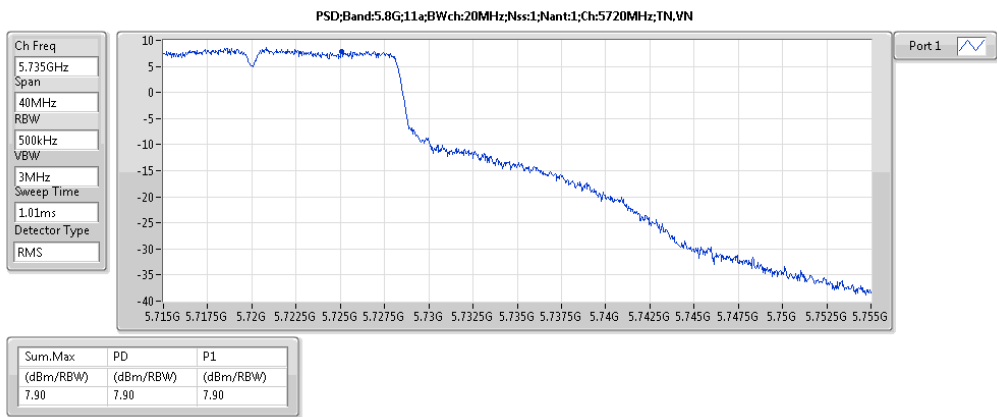
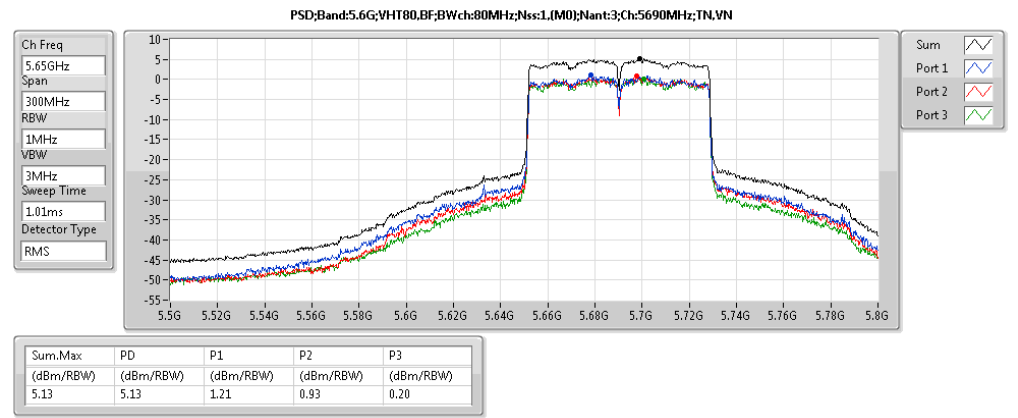
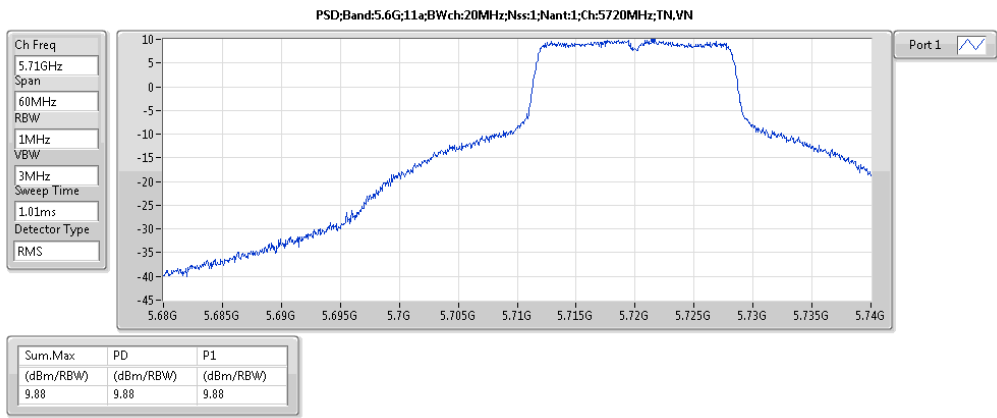



Radiated Emissions (1GHz~40GHz)

<For Non-Beamforming Mode>

Configurations	IEEE 802.11a CH 144 / Chain 3
-----------------------	-------------------------------

Horizontal

	Freq	Level	Limit Line	Over Limit	Read Level	CableAntenna Loss	Antenna Factor	Preamp Factor	A/Pos	T/Pos	Remark	Pol/Phase
	MHz	dBuV/m	dBuV/m	dB	dBuV	dB	dB/m	dB	cm	deg		
1	11435.56	60.06	74.00	-13.94	43.35	11.83	39.62	34.74	233	315	Peak	HORIZONTAL
2	11440.40	46.55	54.00	-7.45	29.84	11.83	39.62	34.74	233	315	Average	HORIZONTAL

Vertical

	Freq	Level	Limit Line	Over Limit	Read Level	CableAntenna Loss	Antenna Factor	Preamp Factor	A/Pos	T/Pos	Remark	Pol/Phase
	MHz	dBuV/m	dBuV/m	dB	dBuV	dB	dB/m	dB	cm	deg		
1	11438.24	60.78	74.00	-13.22	44.07	11.83	39.62	34.74	294	291	Peak	VERTICAL
2	11439.42	46.97	54.00	-7.03	30.26	11.83	39.62	34.74	294	291	Average	VERTICAL



<For Beamforming Mode>

Configurations	IEEE 802.11ac MCS0/Nss1 VHT20 CH 144 / Chain 3 + Chain 4 + Chain 5
-----------------------	--

Horizontal

	Freq	Level	Limit Line	Over Limit	Read Level	CableAntenna Loss	Antenna Factor	Preamp Factor	A/Pos	T/Pos	Remark	Pol/Phase
	MHz	dBuV/m	dBuV/m	dB	dBuV	dB	dB/m	dB	cm	deg		
1	11437.80	51.59	54.00	-2.41	34.88	11.83	39.62	34.74	177	200	Average	HORIZONTAL
2	11440.28	66.02	74.00	-7.98	49.31	11.83	39.62	34.74	177	200	Peak	HORIZONTAL

Vertical

	Freq	Level	Limit Line	Over Limit	Read Level	CableAntenna Loss	Antenna Factor	Preamp Factor	A/Pos	T/Pos	Remark	Pol/Phase
	MHz	dBuV/m	dBuV/m	dB	dBuV	dB	dB/m	dB	cm	deg		
1	11440.70	52.26	54.00	-1.74	35.55	11.83	39.62	34.74	230	269	Average	VERTICAL
2	11441.38	67.55	74.00	-6.45	50.84	11.83	39.62	34.74	230	269	Peak	VERTICAL



Configurations	IEEE 802.11ac MCS0/Nss1 VHT40 CH 142 / Chain 3 + Chain 4 + Chain 5
-----------------------	--

Horizontal

	Freq	Level	Limit Line	Over Limit	Read Level	CableAntenna Loss	Preamp Factor	A/Pos	T/Pos	Remark	Pol/Phase	
	MHz	dBuV/m	dBuV/m	dB	dBuV	dB	dB/m	dB	cm	deg		
1	11418.84	59.79	74.00	-14.21	43.09	11.82	39.62	34.74	150	329	Peak	HORIZONTAL
2	11419.10	46.93	54.00	-7.07	30.23	11.82	39.62	34.74	150	329	Average	HORIZONTAL

Vertical

	Freq	Level	Limit Line	Over Limit	Read Level	CableAntenna Loss	Preamp Factor	A/Pos	T/Pos	Remark	Pol/Phase	
	MHz	dBuV/m	dBuV/m	dB	dBuV	dB	dB/m	dB	cm	deg		
1	11420.32	60.63	74.00	-13.37	43.93	11.82	39.62	34.74	225	251	Peak	VERTICAL
2	11422.86	46.74	54.00	-7.26	30.04	11.82	39.62	34.74	225	251	Average	VERTICAL



Configurations	IEEE 802.11ac MCS0/Nss1 VHT80 CH 138 / Chain 3 + Chain 4 + Chain 5
-----------------------	--

Horizontal

	Freq	Level	Limit Line	Over Limit	Read Level	CableAntenna Loss	Antenna Factor	Preamp Factor	A/Pos	T/Pos	Remark	Pol/Phase
	MHz	dBuV/m	dBuV/m	dB	dBuV	dB	dB/m	dB	cm	deg		
1	11376.48	44.77	54.00	-9.23	28.16	11.80	39.54	34.73	205	220	Average	HORIZONTAL
2	11380.62	57.94	74.00	-16.06	41.32	11.81	39.54	34.73	205	220	Peak	HORIZONTAL

Vertical

	Freq	Level	Limit Line	Over Limit	Read Level	CableAntenna Loss	Antenna Factor	Preamp Factor	A/Pos	T/Pos	Remark	Pol/Phase
	MHz	dBuV/m	dBuV/m	dB	dBuV	dB	dB/m	dB	cm	deg		
1	11377.78	58.29	74.00	-15.71	41.68	11.80	39.54	34.73	228	260	Peak	VERTICAL
2	11385.00	45.01	54.00	-8.99	28.35	11.81	39.58	34.73	228	260	Average	VERTICAL

Note:

The amplitude of spurious emissions that are attenuated by more than 20dB below the permissible value has no need to be reported.

Emission level (dBuV/m) = 20 log Emission level (uV/m).

Corrected Reading: Antenna Factor + Cable Loss + Read Level - Preamp Factor = Level.



Band Edge Emissions

<For Non-Beamforming Mode>

Configurations	IEEE 802.11a CH 144 / Chain 3
----------------	-------------------------------

Channel 144 / Band 3

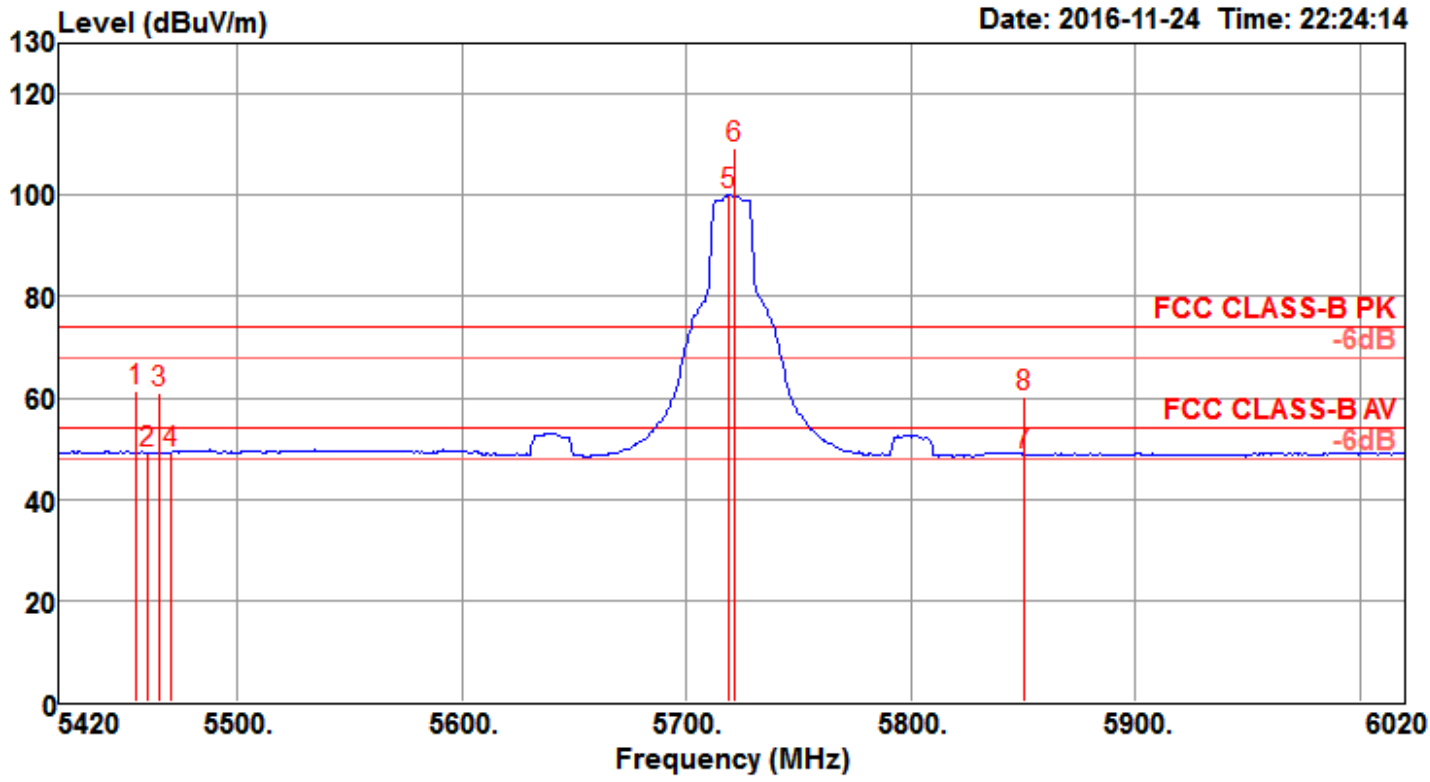

	Freq	Level	Limit	Over	Read	CableAntenna	Preamp	A/Pos	T/Pos	Remark	Pol/Phase	
	MHz	dBuV/m	dBuV/m	dB	dBuV	dB	dB/m	dB	cm	deg		
1	5454.80	61.33	74.00	-12.67	53.12	7.98	35.15	34.92	188	330	Peak	HORIZONTAL
2	5460.00	49.24	54.00	-4.76	41.03	7.98	35.15	34.92	188	330	Average	HORIZONTAL
3	5465.20	60.96	74.00	-13.04	52.71	8.00	35.17	34.92	188	330	Peak	HORIZONTAL
4	5470.00	49.11	54.00	-4.89	40.86	8.00	35.17	34.92	188	330	Average	HORIZONTAL
5 @	5718.80	99.92			91.45	8.17	35.24	34.94	188	330	Average	HORIZONTAL
6 @	5721.20	109.19			100.72	8.17	35.24	34.94	188	330	Peak	HORIZONTAL
7	5850.00	48.69	54.00	-5.31	40.13	8.25	35.27	34.96	188	330	Average	HORIZONTAL
8	5850.00	60.32	74.00	-13.68	51.76	8.25	35.27	34.96	188	330	Peak	HORIZONTAL

Item 5, 6 are the fundamental frequency at 5720 MHz.

Channel 144 / Band 4

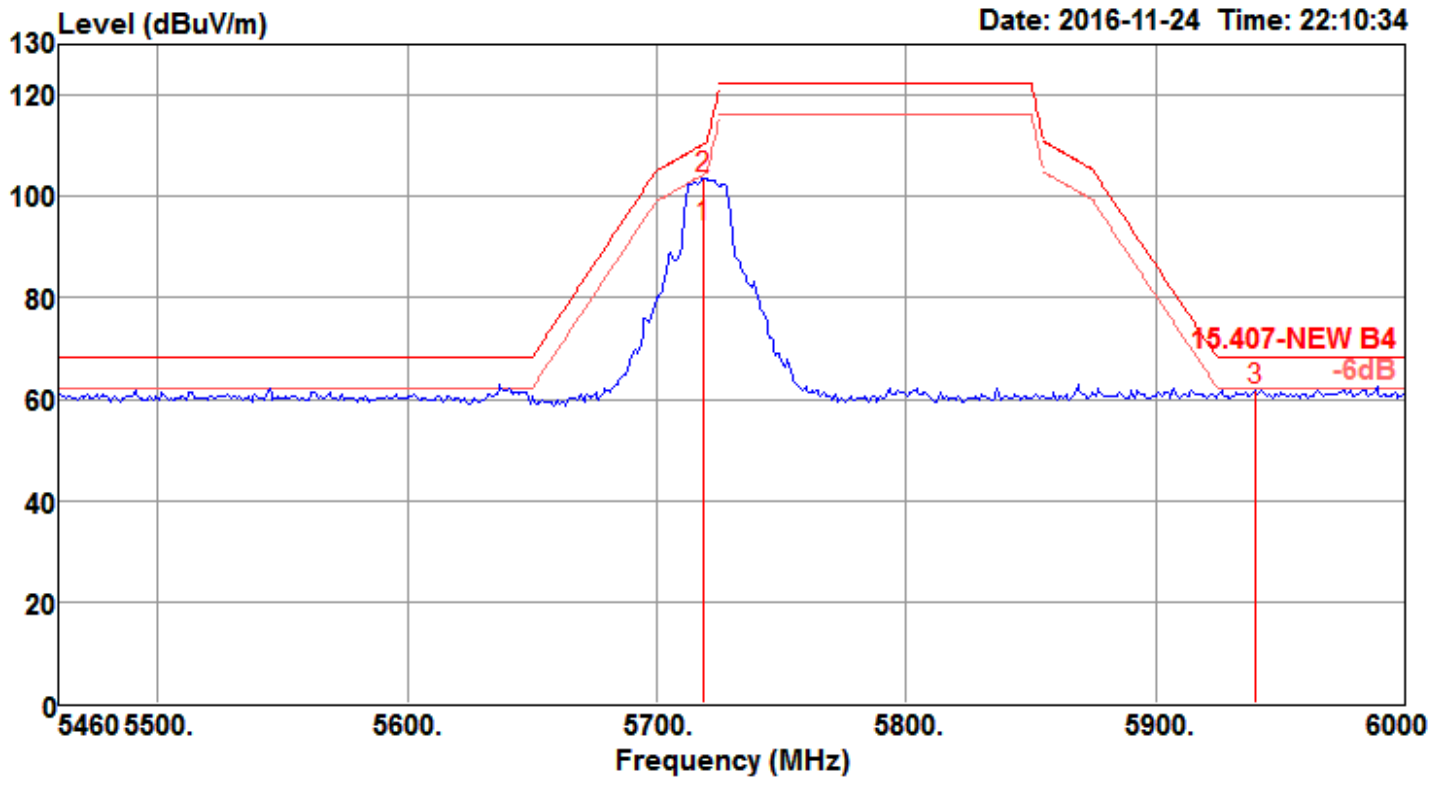

	Freq	Level	Limit Line	Over Limit	Read Level	CableAntenna Loss	Antenna Factor	Preamp Factor	A/Pos	T/Pos	Remark	Pol/Phase
	MHz	dBuV/m	dBuV/m	dB	dBuV	dB	dB/m	dB	cm	deg		
1	5718.80	93.97			85.50	8.17	35.24	34.94	152	202	Average	VERTICAL
2	5718.80	103.50			95.03	8.17	35.24	34.94	152	202	Peak	VERTICAL
3	5939.60	61.87	68.20	-6.33	53.15	8.39	35.29	34.96	152	202	Peak	VERTICAL

Item 1, 2 are the fundamental frequency at 5720 MHz.



<For Beamforming Mode>

Configurations	IEEE 802.11ac MCS0/Nss1 VHT20 CH 144 / Chain 3 + Chain 4 + Chain 5
----------------	--

Channel 144 / Band 3

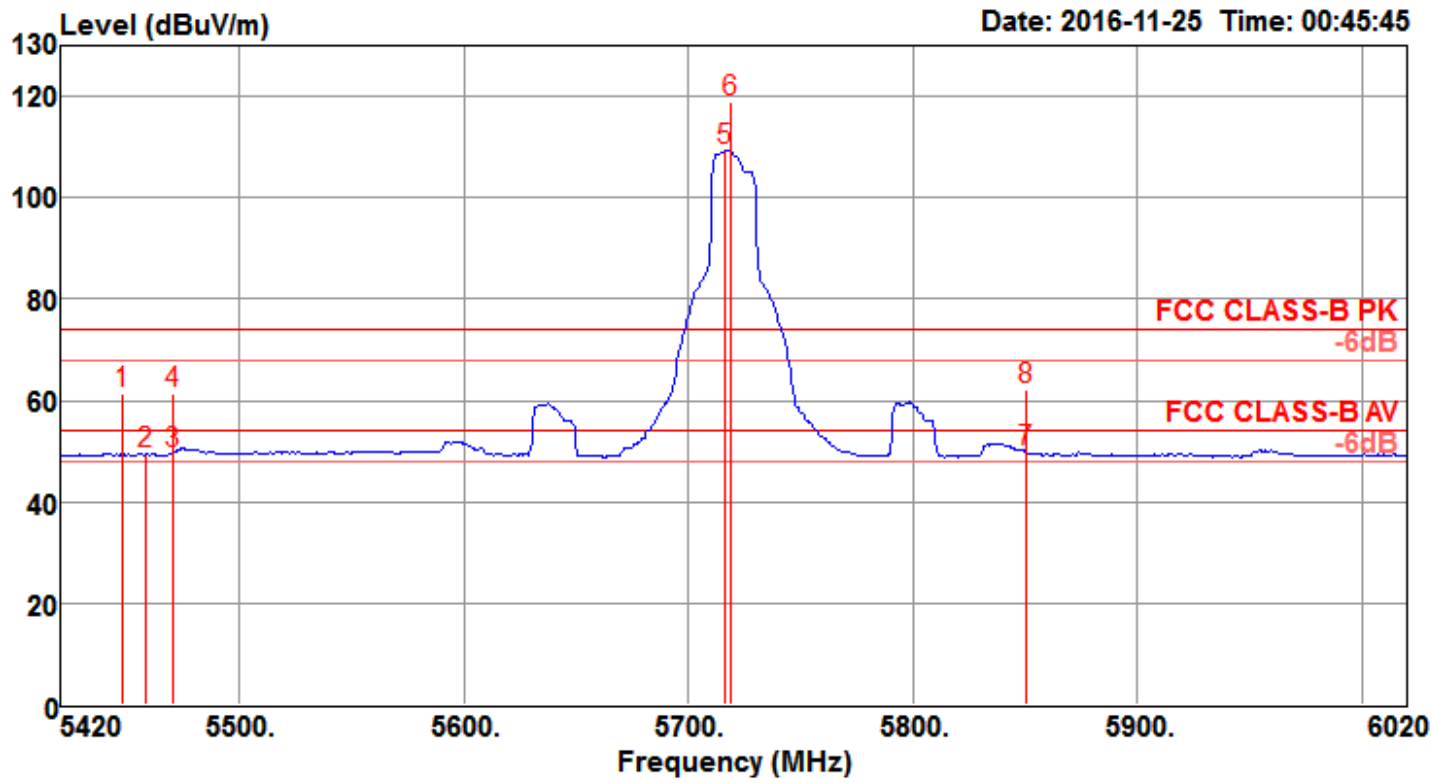

	Freq	Level	Limit	Over	Read	CableAntenna	Preamp	A/Pos	T/Pos	Remark	Pol/Phase
	MHz	dBuV/m	Line	Limit	Level	Loss	Factor	Factor			
			dBuV/m	dB	dBuV	dB	dB/m	dB	cm	deg	
1	5447.60	61.47	74.00	-12.53	53.27	7.98	35.14	34.92	197	211 Peak	HORIZONTAL
2	5458.40	49.39	54.00	-4.61	41.18	7.98	35.15	34.92	197	211 Average	HORIZONTAL
3	5470.00	49.58	54.00	-4.42	41.33	8.00	35.17	34.92	197	211 Average	HORIZONTAL
4	5470.00	61.53	74.00	-12.47	53.28	8.00	35.17	34.92	197	211 Peak	HORIZONTAL
5 @	5716.40	109.24			100.77	8.17	35.24	34.94	197	211 Average	HORIZONTAL
6 @	5718.80	118.82			110.35	8.17	35.24	34.94	197	211 Peak	HORIZONTAL
7	5850.00	49.97	54.00	-4.03	41.41	8.25	35.27	34.96	197	211 Average	HORIZONTAL
8	5850.00	62.21	74.00	-11.79	53.65	8.25	35.27	34.96	197	211 Peak	HORIZONTAL

Item 5, 6 are the fundamental frequency at 5720 MHz.

Channel 144 / Band 4

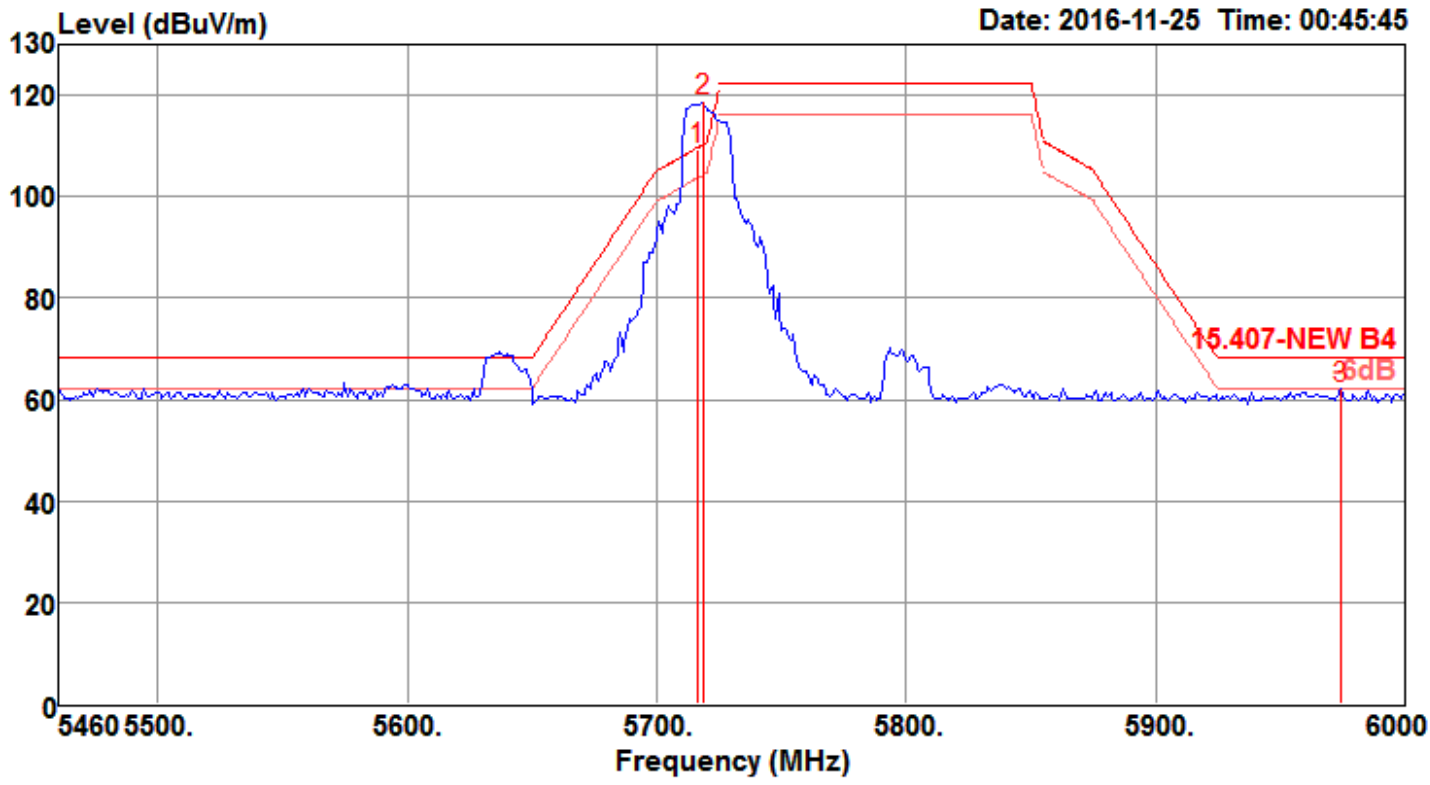

	Freq	Level	Limit	Over	Read	CableAntenna	Preamp	A/Pos	T/Pos	Remark	Pol/Phase	
	MHz	dBuV/m	dBuV/m	dB	dBuV	dB	dB/m	dB	cm	deg		
1	5716.40	109.24			100.77	8.17	35.24	34.94	197	211	Average	HORIZONTAL
2 @	5718.80	118.82			110.35	8.17	35.24	34.94	197	211	Peak	HORIZONTAL
3	5974.40	62.00	68.20	-6.20	53.25	8.43	35.29	34.97	197	211	Peak	HORIZONTAL

Item 1, 2 are the fundamental frequency at 5720 MHz.



Configurations	IEEE 802.11ac MCS0/Nss1 VHT40 CH 142 / Chain 3 + Chain 4 + Chain 5
----------------	--

Channel 142 / Band 3

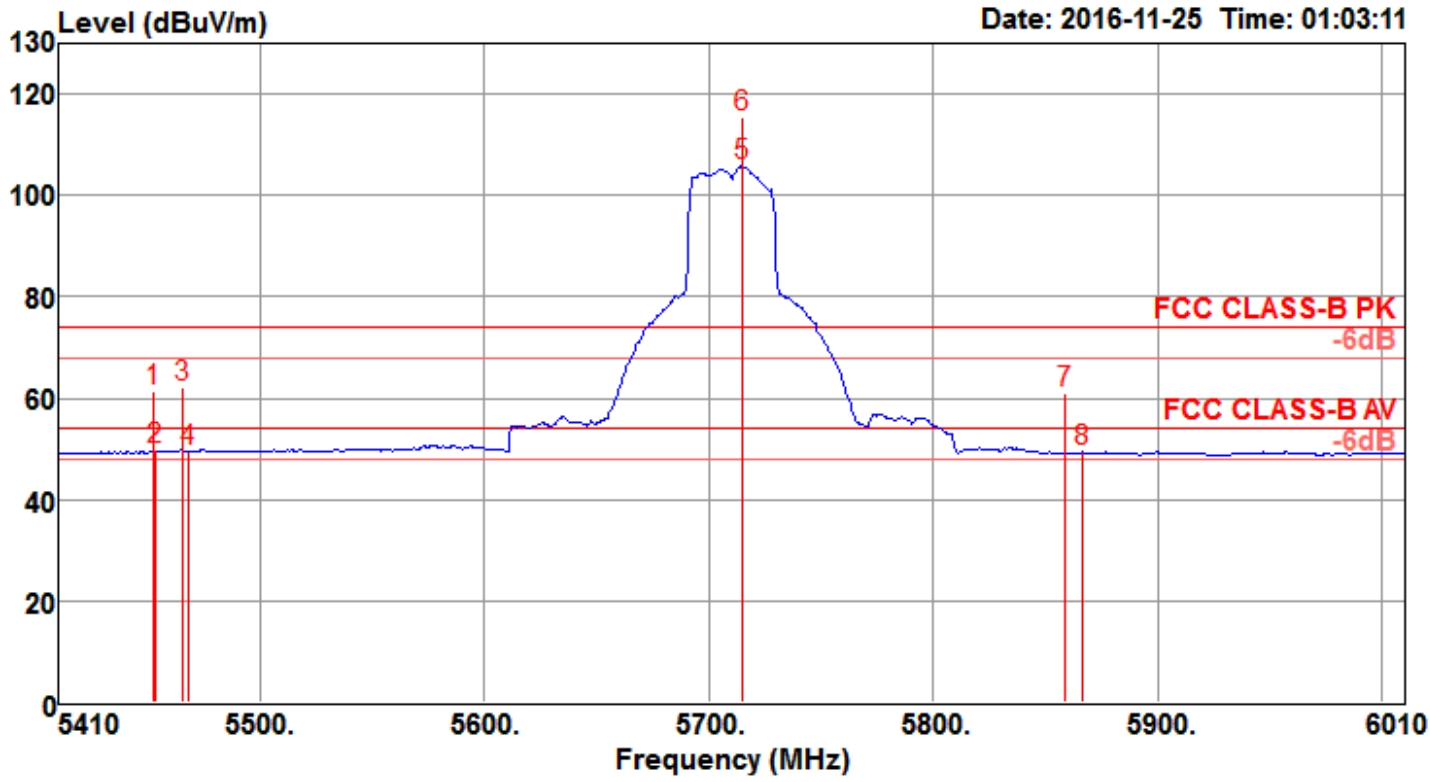

	Freq	Level	Limit Line	Over Limit	Read Level	CableAntenna Loss	Antenna Factor	Preamp Factor	A/Pos	T/Pos	Remark	Pol/Phase
	MHz	dBuV/m	dBuV/m	dB	dBuV	dB	dB/m	dB	cm	deg		
1	5452.80	61.45	74.00	-12.55	53.24	7.98	35.15	34.92	201	211	Peak	HORIZONTAL
2	5453.20	49.75	54.00	-4.25	41.54	7.98	35.15	34.92	201	211	Average	HORIZONTAL
3	5465.20	61.96	74.00	-12.04	53.71	8.00	35.17	34.92	201	211	Peak	HORIZONTAL
4	5467.60	49.66	54.00	-4.34	41.41	8.00	35.17	34.92	201	211	Average	HORIZONTAL
5 @	5714.80	105.70			97.23	8.17	35.24	34.94	201	211	Average	HORIZONTAL
6 @	5714.80	115.38			106.91	8.17	35.24	34.94	201	211	Peak	HORIZONTAL
7	5858.40	61.03	74.00	-12.97	52.45	8.27	35.27	34.96	201	211	Peak	HORIZONTAL
8	5866.00	49.44	54.00	-4.56	40.86	8.27	35.27	34.96	201	211	Average	HORIZONTAL

Item 5, 6 are the fundamental frequency at 5710 MHz.

Channel 142 / Band 4

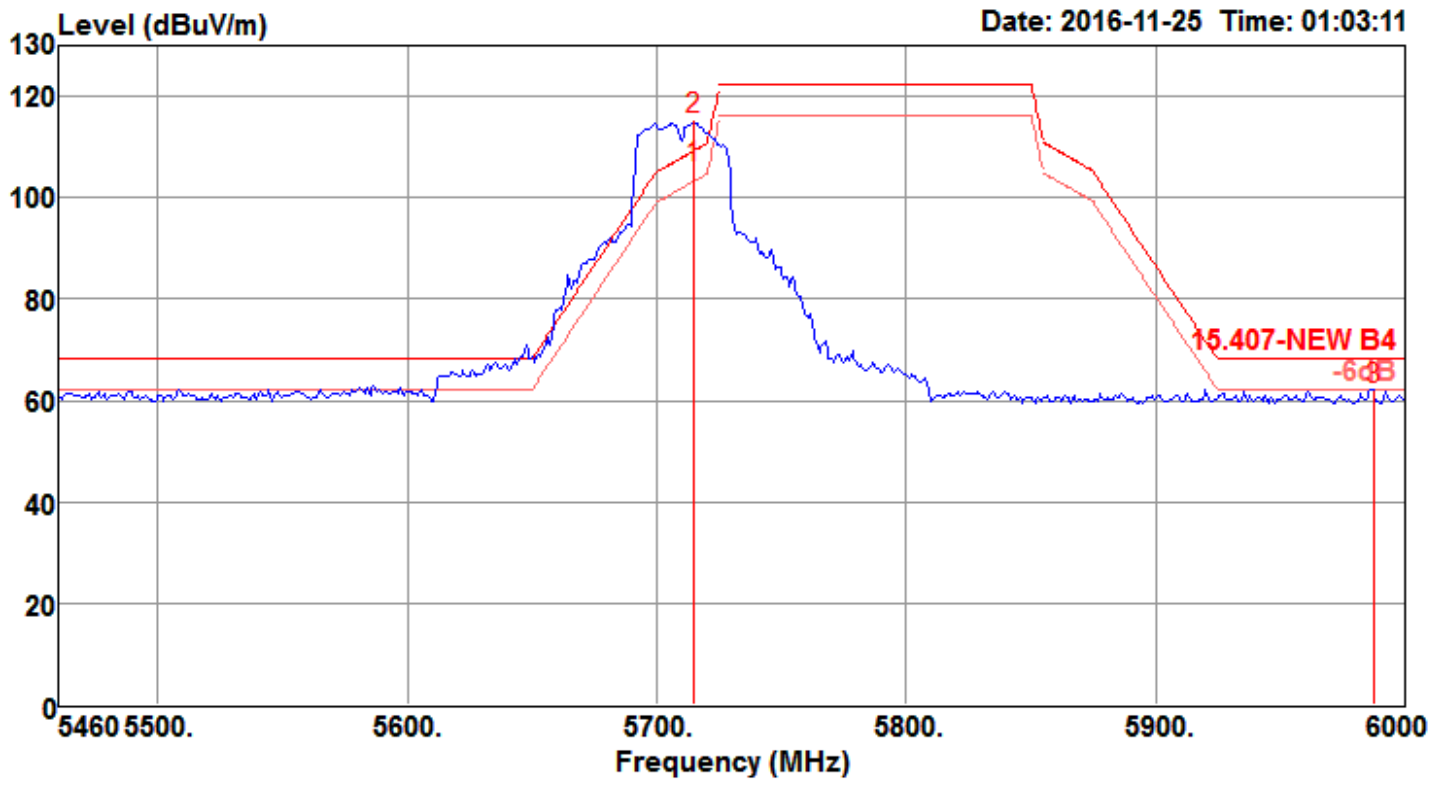

	Freq	Level	Limit Line	Over Limit	Read Level	CableAntenna Loss	Preamp Factor	A/Pos	T/Pos	Remark	Pol/Phase	
	MHz	dBuV/m	dBuV/m	dB	dBuV	dB	dB/m	dB	cm	deg		
1	5714.80	105.70			97.23	8.17	35.24	34.94	201	211	Average	HORIZONTAL
2 @	5714.80	115.38			106.91	8.17	35.24	34.94	201	211	Peak	HORIZONTAL
3	5987.20	62.05	68.20	-6.15	53.29	8.43	35.30	34.97	201	211	Peak	HORIZONTAL

Item 1, 2 are the fundamental frequency at 5710 MHz.



Configurations	IEEE 802.11ac MCS0/Nss1 VHT80 CH 138 / Chain 3 + Chain 4 + Chain 5
----------------	--

Channel 138 / Band 3

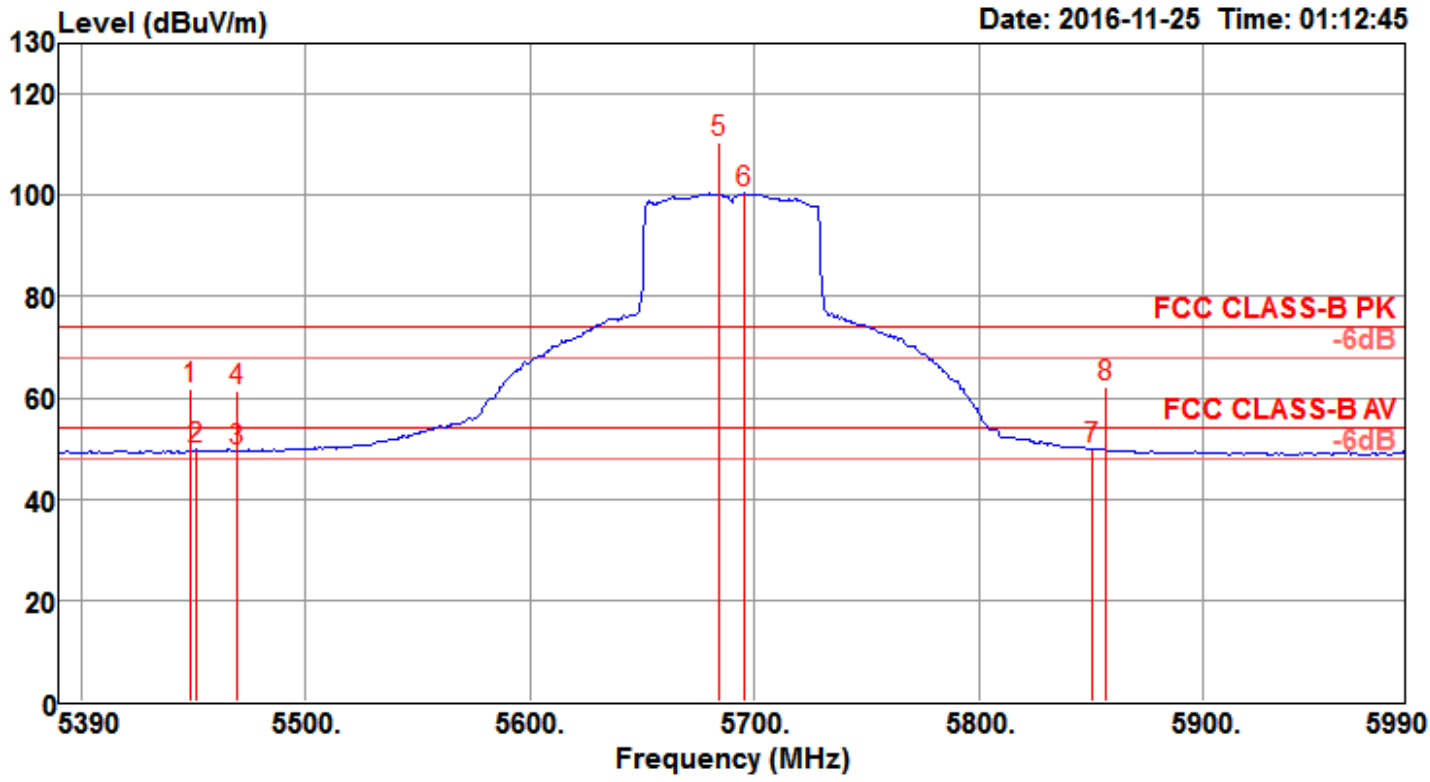

	Freq	Level	Limit	Over	Read	CableAntenna	Preamp	A/Pos	T/Pos	Remark	Pol/Phase	
	MHz	dBuV/m	dBuV/m	dB	dBuV	dB	dB/m	dB	cm	deg		
1	5449.20	61.57	74.00	-12.43	53.36	7.98	35.15	34.92	195	186	Peak	VERTICAL
2	5451.20	49.70	54.00	-4.30	41.49	7.98	35.15	34.92	195	186	Average	VERTICAL
3	5470.00	49.48	54.00	-4.52	41.23	8.00	35.17	34.92	195	186	Average	VERTICAL
4	5470.00	61.25	74.00	-12.75	53.00	8.00	35.17	34.92	195	186	Peak	VERTICAL
5 @	5684.00	110.64			102.17	8.17	35.24	34.94	195	186	Peak	VERTICAL
6 @	5696.00	100.37			91.90	8.17	35.24	34.94	195	186	Average	VERTICAL
7	5850.80	49.82	54.00	-4.18	41.26	8.25	35.27	34.96	195	186	Average	VERTICAL
8	5856.80	62.10	74.00	-11.90	53.52	8.27	35.27	34.96	195	186	Peak	VERTICAL

Item 5, 6 are the fundamental frequency at 5690 MHz.

Channel 138 / Band 4

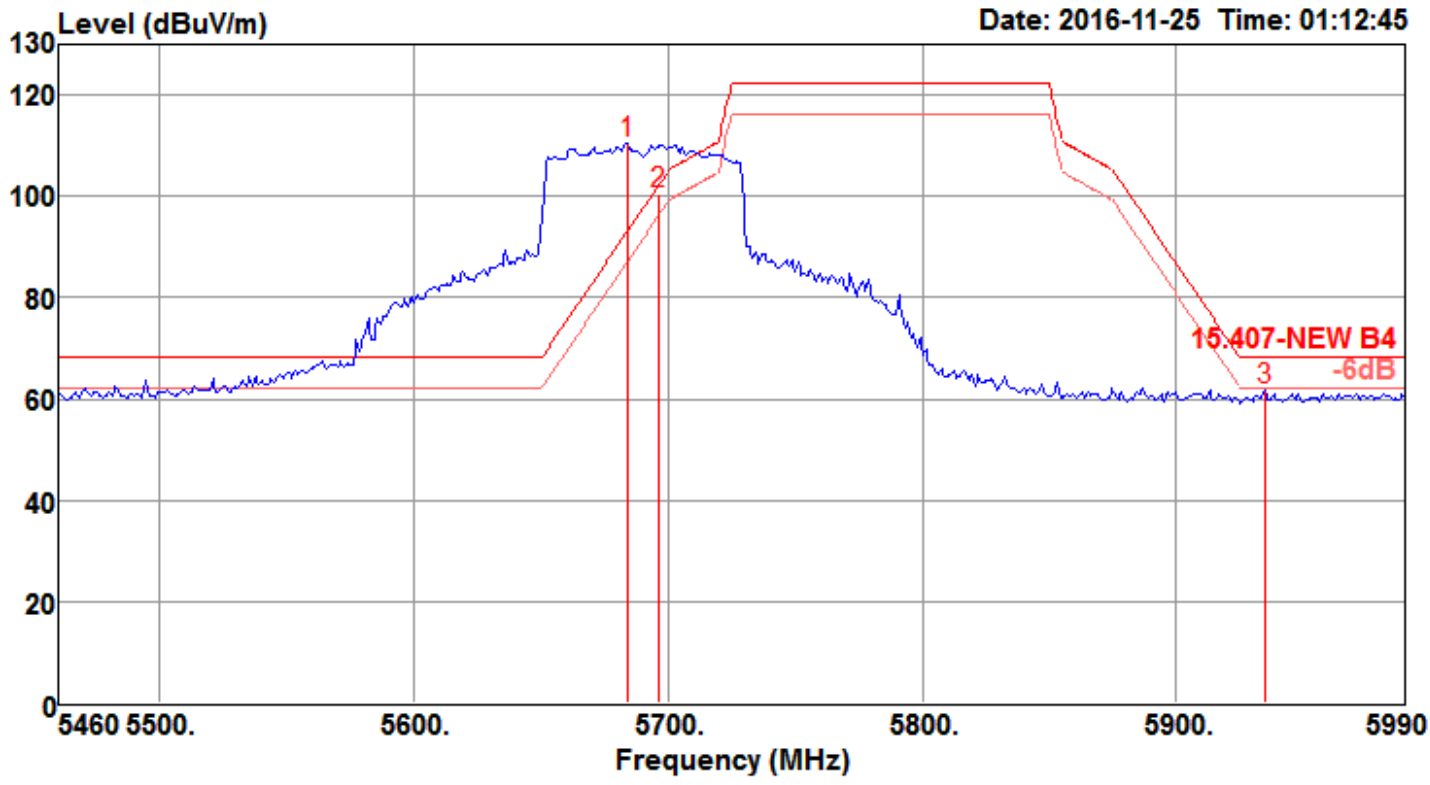

	Freq	Level	Limit	Over	Read	CableAntenna	Preamp	A/Pos	T/Pos	Remark	Pol/Phase	
	MHz	dBuV/m	dBuV/m	dB	dBuV	dB	dB/m	dB	cm	deg		
1 @	5684.00	110.64			102.17	8.17	35.24	34.94	195	186	Peak	VERTICAL
2	5696.00	100.37			91.90	8.17	35.24	34.94	195	186	Average	VERTICAL
3	5934.80	61.63	68.20	-6.57	52.94	8.36	35.29	34.96	195	186	Peak	VERTICAL

Item 1, 2 are the fundamental frequency at 5690 MHz.

Note:

Emission level (dBuV/m) = 20 log Emission level (uV/m)

Corrected Reading: Antenna Factor + Cable Loss + Read Level - Preamp Factor = Level