



SPORTON International Inc.

No. 52, Hwa Ya 1st Rd., Hwa Ya Technology Park, Kwei-Shan Hsiang, Tao Yuan Hsien, Taiwan, R.O.C.
Ph: 886-3-327-3456 / FAX: 886-3-327-0973 / www.sporton.com.tw

FCC RADIO TEST REPORT

| | |
|------------------------|---|
| Applicant's company | AirTies Wireless Networks |
| Applicant Address | Gülbahar Mah. Avni Dilligil Sok. Celik Is Merkezi No 5 meci diyekoy ISTANBUL, 34394 Turkey |
| FCC ID | Z3WAI R49200 |
| Manufacturer's company | SHENZHEN GONGJIN ELECTRONICS CO.,LTD. |
| Manufacturer Address | 2F/3F/4F Baiying Building, 1019#Naihai RD, Nanshan Dist., Shenzhen, Guangdong, CHINA |

| | |
|------------------|--|
| Product Name | 2 Port Gigabit Ethernet 11ac/11n Wireless Router |
| Brand Name | AirTies |
| Model No. | Air 4920 |
| Test Rule | 47 CFR FCC Part 15 Subpart C § 15.247 |
| Test Freq. Range | 2400 ~ 2483.5MHz |
| Received Date | Nov. 25, 2015 |
| Final Test Date | Nov. 30, 2015 |
| Submission Type | Class II Change |

Statement

Test result included in this report is for the IEEE 802.11n and IEEE 802.11b/g of the product.

The test result in this report refers exclusively to the presented test model / sample.

Without written approval of SPORTON International Inc., the test report shall not be reproduced except in full.

The measurements and test results shown in this test report were made in accordance with the procedures and found in compliance with the limit given in **ANSI C63.10-2013, 47 CFR FCC Part 15 Subpart C, KDB558074 D01 v03r05 and KDB 662911 D01 v02r01.**

The test equipment used to perform the test is calibrated and traceable to NML/ROC.





Table of Contents

| | |
|---|----------------|
| 1. VERIFICATION OF COMPLIANCE | 1 |
| 2. SUMMARY OF THE TEST RESULT | 2 |
| 3. GENERAL INFORMATION | 3 |
| 3.1. Product Details..... | 3 |
| 3.2. Accessories..... | 4 |
| 3.3. Table for Filed Antenna..... | 5 |
| 3.4. Table for Carrier Frequencies | 6 |
| 3.5. Table for Test Modes | 7 |
| 3.6. Table for Testing Locations..... | 7 |
| 3.7. Table for Class II Change | 7 |
| 3.8. Table for Supporting Units | 8 |
| 3.9. EUT Operation during Test | 8 |
| 3.10. Test Configurations | 9 |
| 4. TEST RESULT | 11 |
| 4.1. AC Power Line Conducted Emissions Measurement..... | 11 |
| 4.2. Radiated Emissions Measurement | 15 |
| 4.3. Antenna Requirements | 21 |
| 5. LIST OF MEASURING EQUIPMENTS | 22 |
| 6. MEASUREMENT UNCERTAINTY | 23 |
| APPENDIX A. TEST PHOTOS | A1 ~ A4 |



History of This Test Report

| REPORT NO. | VERSION | DESCRIPTION | ISSUED DATE |
|---------------|---------|-------------------------|---------------|
| FR552501-04AA | Rev. 01 | Initial issue of report | Apr. 25, 2016 |
| | | | |
| | | | |
| | | | |
| | | | |
| | | | |
| | | | |
| | | | |
| | | | |
| | | | |
| | | | |
| | | | |
| | | | |
| | | | |
| | | | |



1. VERIFICATION OF COMPLIANCE

Product Name : 2 Port Gigabit Ethernet 11ac/11n Wireless Router
Brand Name : AirTies
Model No. : Air 4920
Applicant : AirTies Wireless Networks
Test Rule Part(s) : 47 CFR FCC Part 15 Subpart C § 15.247

Sporton International as requested by the applicant to evaluate the EMC performance of the product sample received on Nov. 25, 2015 would like to declare that the tested sample has been evaluated and found to be in compliance with the tested rule parts. The data recorded as well as the test configuration specified is true and accurate for showing the sample's EMC nature.

A handwritten signature in blue ink that reads "Sam Chen". The signature is written over a horizontal line.

Sam Chen

SPORTON INTERNATIONAL INC.

2. SUMMARY OF THE TEST RESULT

| Applied Standard: 47 CFR FCC Part 15 Subpart C | | | | |
|--|--------------|-----------------------------------|----------|-------------|
| Part | Rule Section | Description of Test | Result | Under Limit |
| 4.1 | 15.207 | AC Power Line Conducted Emissions | Complies | 18.38 dB |
| 4.2 | 15.247(d) | Radiated Emissions | Complies | 3.43 dB |
| 4.3 | 15.203 | Antenna Requirements | Complies | - |

3. GENERAL INFORMATION

3.1. Product Details

| Items | Description |
|---------------------|--|
| Product Type | IEEE 802.11b/g: WLAN (1TX, 1RX) IEEE 802.11n: WLAN (2TX, 2RX) |
| Radio Type | Intentional Transceiver |
| Power Type | From power adapter |
| Modulation | IEEE 802.11b: DSSS IEEE 802.11g: OFDM IEEE 802.11n: see the below table |
| Data Modulation | IEEE 802.11b: DSSS (BPSK / QPSK / CCK) IEEE 802.11g/n: OFDM (BPSK / QPSK / 16QAM / 64QAM) |
| Data Rate (Mbps) | IEEE 802.11b: DSSS (1/ 2/ 5.5/11) IEEE 802.11g: OFDM (6/9/12/18/24/36/48/54) IEEE 802.11n: see the below table |
| Frequency Range | 2400 ~ 2483.5MHz |
| Channel Number | 11 for 20MHz bandwidth ; 7 for 40MHz bandwidth |
| Carrier Frequencies | Please refer to section 3.4 |
| Antenna | Please refer to section 3.3 |

| Items | Description |
|----------------------|---|
| Beamforming Function | <input checked="" type="checkbox"/> With beamforming <input type="checkbox"/> Without beamforming |
| | The product has beamforming function for 802.11n/ac in 5GHz. |

Antenna and Band width

| Antenna | Single (TX) | | Two (TX) | |
|--------------|-------------|--------|----------|--------|
| | 20 MHz | 40 MHz | 20 MHz | 40 MHz |
| IEEE 802.11b | V | X | X | X |
| IEEE 802.11g | V | X | X | X |
| IEEE 802.11n | X | X | V | V |

IEEE 11n Spec.

| Protocol | Number of Transmit Chains (NTX) | Data Rate / MCS |
|---|---------------------------------|-----------------|
| 802.11n (HT20) | 2 | MCS 0-15 |
| 802.11n (HT40) | 2 | MCS 0-15 |
| Note 1: IEEE Std. 802.11n modulation consists of HT20 and HT40 (HT: High Throughput). Then EUT supports HT20 and HT40. Note 2: Modulation modes consist of below configuration: HT20/HT40: IEEE 802.11n | | |

3.2. Accessories

| Power | Brand | Model | Rating |
|---------|-------|------------------------|--|
| Adapter | MOSO | MSA-C1000IC12.0-12W-US | Input: 100-240Vac, 50/60Hz, 0.5A max. Output: 12.0Vdc, 1A |

3.3. Table for Filed Antenna

| Ant. | Brand | Model Name | Antenna Type | Connector | Gain (dBi) | |
|------|---------|---------------|--------------|-----------|------------|------|
| | | | | | 2.4GHz | 5GHz |
| 1 | - | - | PCB Antenna | N/A | 2.5 | - |
| 2 | Airgain | N2420S-T-G50U | PIFA Antenna | I-PEX | 2.5 | - |
| 3 | - | - | PCB Antenna | N/A | - | 0 |
| 4 | - | - | PCB Antenna | N/A | - | 0 |
| 5 | - | - | PCB Antenna | N/A | - | 0 |

Note: The EUT has five antennas. There are two antennas for 2.4GHz and three antennas for 5GHz.

For 2.4GHz band:

For 802.11b/g mode:

Only Chain 1 could transmit/receive simultaneously.

For 802.11n mode:

Chain 1 and Chain 2 could transmit/receive simultaneously.

For 5GHz band:

For 802.11a mode:

Only Chain 3 could transmit/receive simultaneously.

For 802.11n/ac mode:

Chain 3, Chain 4 and Chain 5 could transmit/receive simultaneously.

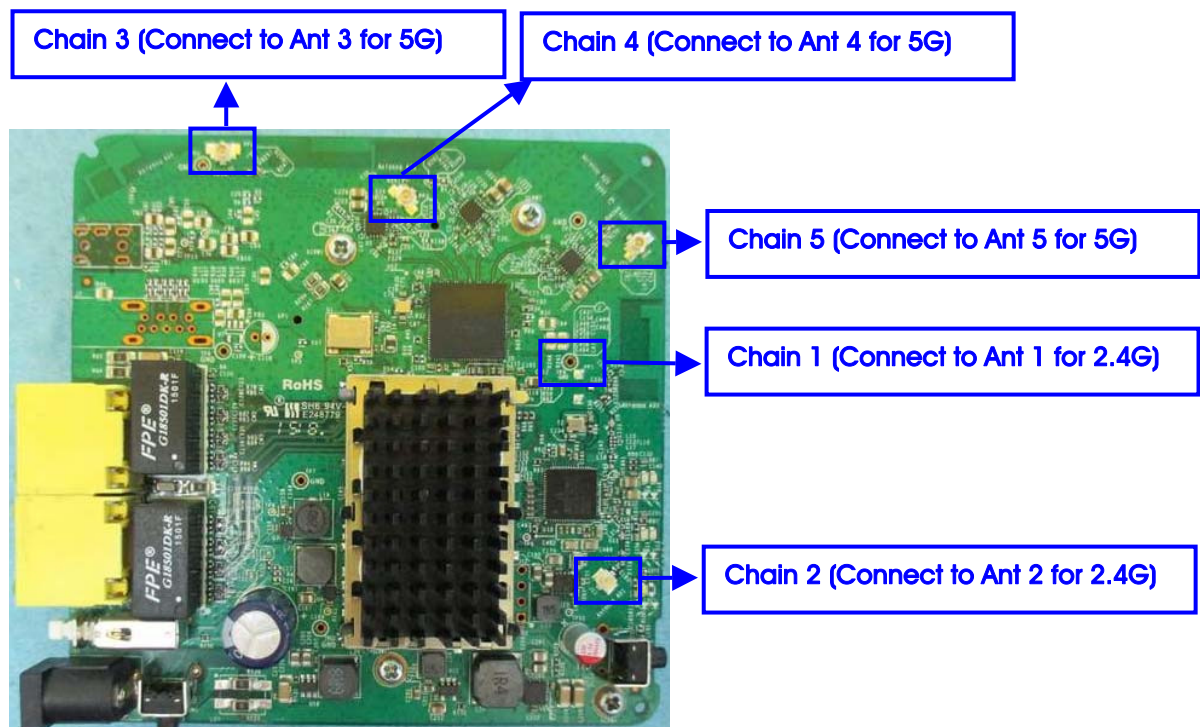

3.4. Table for Carrier Frequencies

There are two bandwidth systems.

For 20MHz bandwidth systems, use Channel 1~Channel 11.

For 40MHz bandwidth systems, use Channel 3~Channel 9.

| Frequency Band | Channel No. | Frequency | Channel No. | Frequency |
|----------------|-------------|-----------|-------------|-----------|
| 2400~2483.5MHz | 1 | 2412 MHz | 7 | 2442 MHz |
| | 2 | 2417 MHz | 8 | 2447 MHz |
| | 3 | 2422 MHz | 9 | 2452 MHz |
| | 4 | 2427 MHz | 10 | 2457 MHz |
| | 5 | 2432 MHz | 11 | 2462 MHz |
| | 6 | 2437 MHz | - | - |

3.5. Table for Test Modes

Preliminary tests were performed in different data rate to find the worst radiated emission. The data rate shown in the table below is the worst-case rate with respect to the specific test item. Investigation has been done on all the possible configurations for searching the worst cases. The following table is a list of the test modes shown in this test report.

| Test Items | Mode | Data Rate | Channel | Chain |
|-----------------------------------|-------------|-----------|---------|-------|
| AC Power Line Conducted Emissions | Normal Link | - | - | - |
| Radiated Emissions 9kHz~1GHz | Normal Link | - | - | - |

3.6. Table for Testing Locations

| Test Site Location | | | | |
|--------------------|--|----------|---------------------|-------------|
| Address: | No.8, Lane 724, Bo-ai St., Jhubei City, Hsinchu County 302, Taiwan, R.O.C. | | | |
| TEL: | 886-3-656-9065 | | | |
| FAX: | 886-3-656-9085 | | | |
| Test Site No. | Site Category | Location | FCC Designation No. | IC File No. |
| 03CH01-CB | SAC | Hsin Chu | TW0006 | IC 4086D |
| CO01-CB | Conduction | Hsin Chu | TW0006 | IC 4086D |

Open Area Test Site (OATS); Semi Anechoic Chamber (SAC).

3.7. Table for Class II Change

This product is an extension of original one reported under Sporton project number: FR552501

Below is the table for the change of the product with respect to the original one.

| Modifications | Performance Checking |
|---|--|
| 1. Changing the applicant address. | It does not affect the test result. |
| 2. Changing the color of housing. | |
| 3. Changing the adapter to model: MSA-C1000IC12.0-12W-US. | 1. AC Power Line Conducted Emissions. 2. Radiated Emissions Below 1GHz. |
| 4. Updating test rule of 5GHz Band 4 (5725~5850 MHz) to "New Rules" from "Old Rules". | It does not affect the test result of 2.4GHz Band. |

3.8. Table for Supporting Units

For Test Site No: 03CH01-CB

| Support Unit | Brand | Model | FCC ID |
|--------------|-------|-------|--------|
| Notebook*3 | DELL | E4300 | DoC |

For Test Site No: CO01-CB

| Support Unit | Brand | Model | FCC ID |
|--------------|-------|-------|--------|
| Notebook*3 | DELL | E6430 | DoC |

3.9. EUT Operation during Test

The EUT was programmed to be in continuously transmitting mode.

3.10. Test Configurations

3.10.1. AC Power Line Conduction Emissions Test Configuration

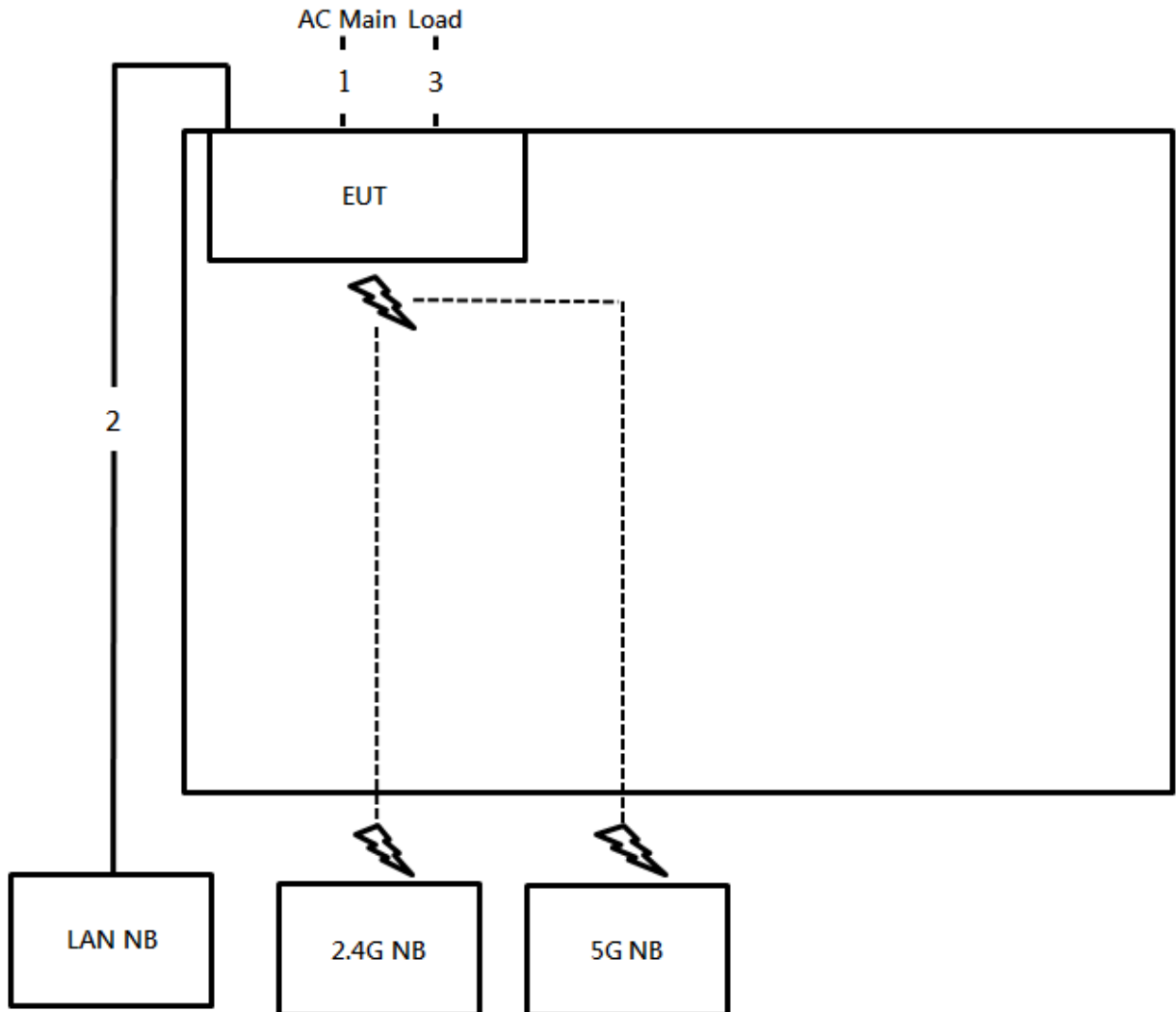

| Item | Connection | Shielded | Length |
|------|-------------|----------|--------|
| 1 | Power cable | No | 1.5m |
| 2 | RJ-45 cable | No | 10m |
| 3 | RJ-45 cable | No | 1.5m |

3.10.2. Radiation Emissions Test Configuration

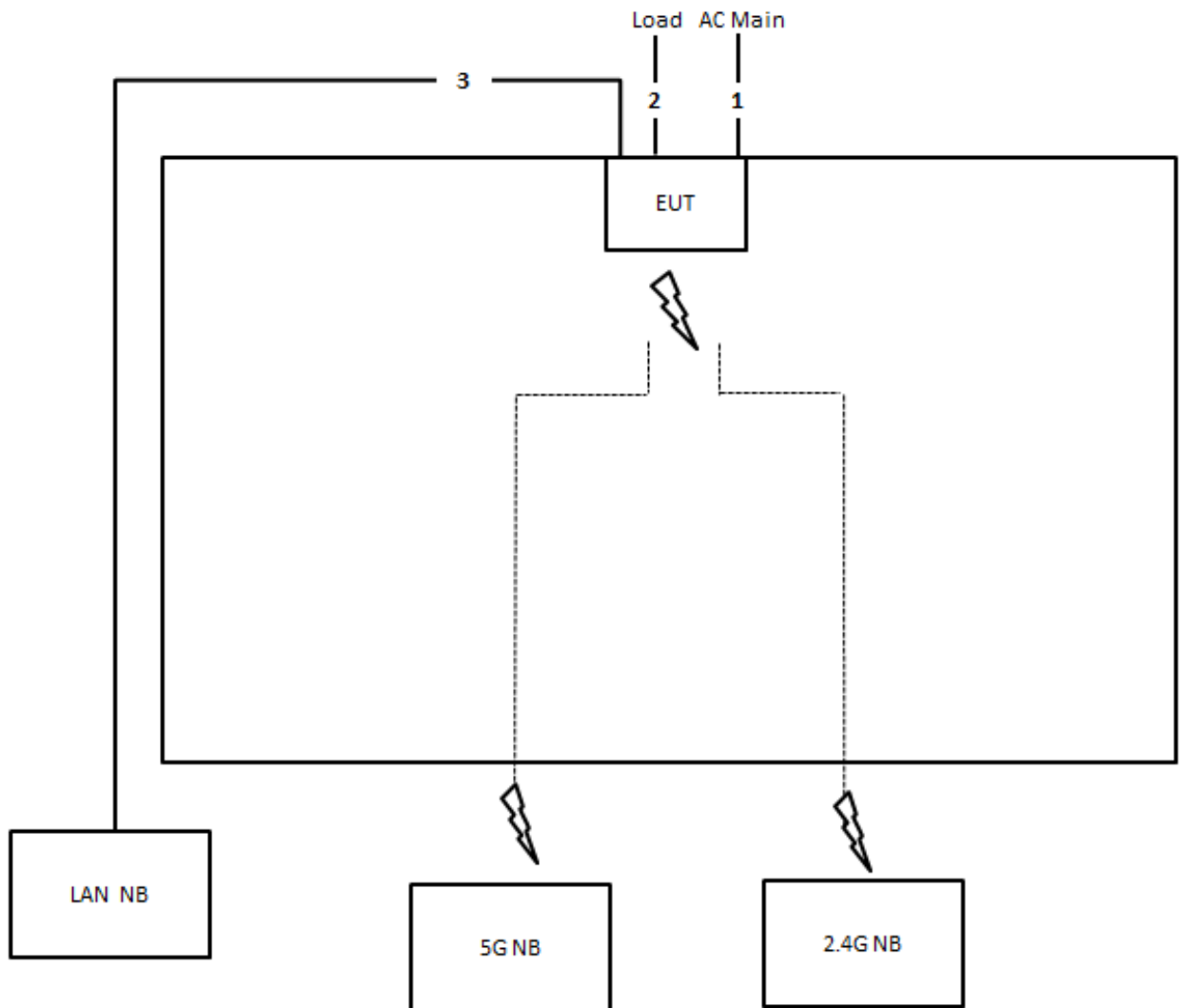

| Item | Connection | Shielded | Length |
|------|-------------|----------|--------|
| 1 | Power cable | No | 1.5m |
| 2 | RJ-45 cable | No | 1.5m |
| 3 | RJ-45 cable | No | 10m |

4. TEST RESULT

4.1. AC Power Line Conducted Emissions Measurement

4.1.1. Limit

For this product which is designed to be connected to the AC power line, the radio frequency voltage that is conducted back onto the AC power line on any frequency or frequencies within the band 150 kHz to 30 MHz shall not exceed below limits table.

| Frequency (MHz) | QP Limit (dBuV) | AV Limit (dBuV) |
|-----------------|-----------------|-----------------|
| 0.15~0.5 | 66~56 | 56~46 |
| 0.5~5 | 56 | 46 |
| 5~30 | 60 | 50 |

4.1.2. Measuring Instruments and Setting

Please refer to section 5 of equipments list in this report. The following table is the setting of the receiver.

| Receiver Parameters | Setting |
|---------------------|----------|
| Attenuation | 10 dB |
| Start Frequency | 0.15 MHz |
| Stop Frequency | 30 MHz |
| IF Bandwidth | 9 kHz |

4.1.3. Test Procedures

1. Configure the EUT according to ANSI C63.10. The EUT or host of EUT has to be placed 0.4 meter far from the conducting wall of the shielding room and at least 80 centimeters from any other grounded conducting surface.
2. Connect EUT or host of EUT to the power mains through a line impedance stabilization network (LISN).
3. All the support units are connected to the other LISNs. The LISN should provide 50uH/50ohms coupling impedance.
4. The frequency range from 150 kHz to 30 MHz was searched.
5. Set the test-receiver system to Peak Detect Function and Specified Bandwidth with Maximum Hold Mode.
6. The measurement has to be done between each power line and ground at the power terminal.

4.1.4. Test Setup Layout

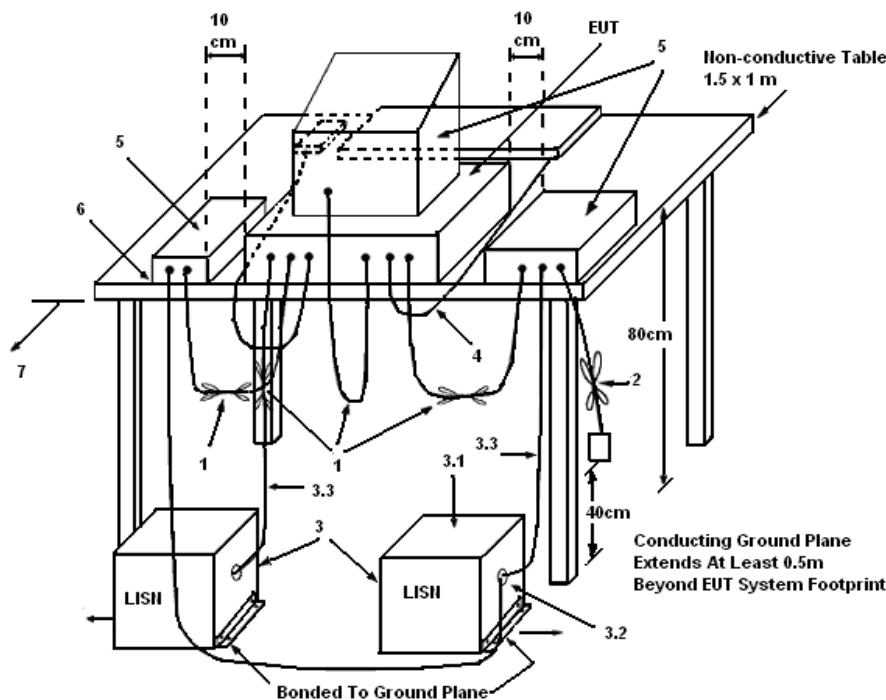

LEGEND:

- (1) Interconnecting cables that hang closer than 40 cm to the ground plane shall be folded back and forth in the center forming a bundle 30 to 40 cm long.
- (2) I/O cables that are not connected to a peripheral shall be bundled in the center. The end of the cable may be terminated, if required, using the correct terminating impedance. The overall length shall not exceed 1 m.
- (3) EUT connected to one LISN. Unused LISN measuring port connectors shall be terminated in 50 Ω . LISN can be placed on top of, or immediately beneath, reference ground plane.
 - (3.1) All other equipment powered from additional LISN(s).
 - (3.2) Multiple outlet strip can be used for multiple power cords of non-EUT equipment.
 - (3.3) LISN at least 80 cm from nearest part of EUT chassis.
- (4) Cables of hand-operated devices, such as keyboards, mice, etc., shall be placed as for normal use.
- (5) Non-EUT components of EUT system being tested.
- (6) Rear of EUT, including peripherals, shall all be aligned and flush with rear of tabletop.
- (7) Rear of tabletop shall be 40 cm removed from a vertical conducting plane that is bonded to the ground plane.

4.1.5. Test Deviation

There is no deviation with the original standard.

4.1.6. EUT Operation during Test

The EUT was placed on the test table and programmed in normal function.

4.1.7. Results of AC Power Line Conducted Emissions Measurement

| | | | |
|---------------|-------------|----------|------|
| Temperature | 25°C | Humidity | 55% |
| Test Engineer | Ryo Fan | Phase | Line |
| Configuration | Normal Link | | |

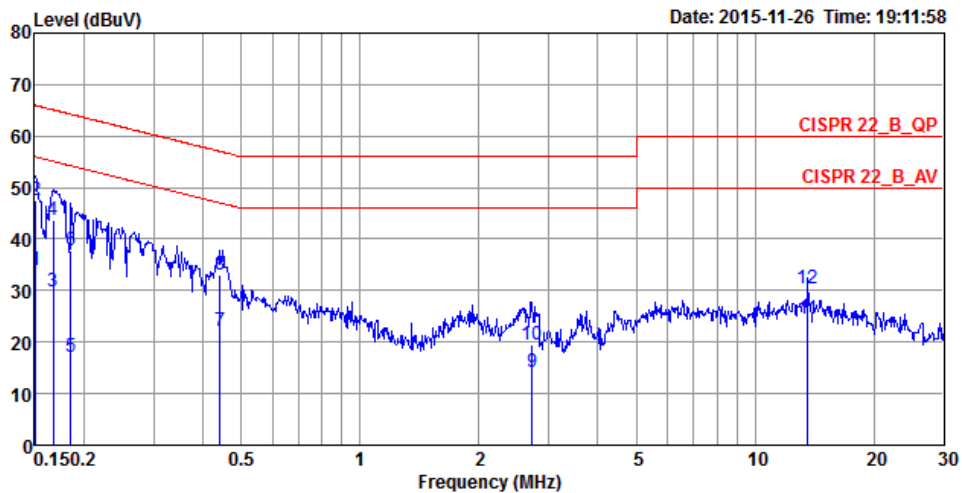

| | Freq | Level | Over Limit | Limit Line | Read Level | LISN Factor | Cable Loss | Pol/Phase | Remark |
|----|---------|-------|------------|------------|------------|-------------|------------|-----------|---------|
| | MHz | dBuV | dB | dBuV | dBuV | dB | dB | | |
| 1 | 0.1508 | 33.88 | -22.08 | 55.96 | 23.93 | 9.93 | 0.02 | LINE | Average |
| 2 | 0.1508 | 47.58 | -18.38 | 65.96 | 37.63 | 9.93 | 0.02 | LINE | QP |
| 3 | 0.1668 | 29.88 | -25.24 | 55.12 | 19.93 | 9.93 | 0.02 | LINE | Average |
| 4 | 0.1668 | 43.55 | -21.57 | 65.12 | 33.60 | 9.93 | 0.02 | LINE | QP |
| 5 | 0.1854 | 17.21 | -37.03 | 54.24 | 7.26 | 9.93 | 0.02 | LINE | Average |
| 6 | 0.1854 | 37.66 | -26.58 | 64.24 | 27.71 | 9.93 | 0.02 | LINE | QP |
| 7 | 0.4421 | 22.24 | -24.78 | 47.02 | 12.27 | 9.93 | 0.04 | LINE | Average |
| 8 | 0.4421 | 32.92 | -24.10 | 57.02 | 22.95 | 9.93 | 0.04 | LINE | QP |
| 9 | 2.7212 | 14.11 | -31.89 | 46.00 | 4.06 | 10.00 | 0.05 | LINE | Average |
| 10 | 2.7212 | 19.51 | -36.49 | 56.00 | 9.46 | 10.00 | 0.05 | LINE | QP |
| 11 | 13.6228 | 24.55 | -25.45 | 50.00 | 14.00 | 10.30 | 0.25 | LINE | Average |
| 12 | 13.6228 | 30.55 | -29.45 | 60.00 | 20.00 | 10.30 | 0.25 | LINE | QP |

| | | | |
|---------------|-------------|----------|---------|
| Temperature | 25°C | Humidity | 55% |
| Test Engineer | Ryo Fan | Phase | Neutral |
| Configuration | Normal Link | | |

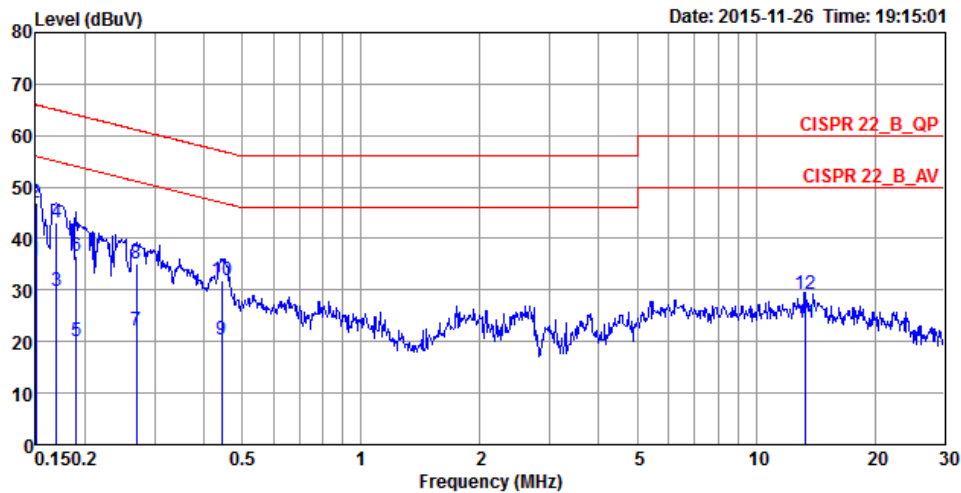

| | Freq | Level | Over Limit | Limit Line | Read Level | LISN Factor | Cable Loss | Pol/Phase | Remark |
|----|---------|-------|------------|------------|------------|-------------|------------|-----------|---------|
| | MHz | dBuV | dB | dBuV | dBuV | dB | dB | | |
| 1 | 0.1500 | 35.72 | -20.28 | 56.00 | 25.92 | 9.78 | 0.02 | NEUTRAL | Average |
| 2 | 0.1500 | 46.97 | -19.03 | 66.00 | 37.17 | 9.78 | 0.02 | NEUTRAL | QP |
| 3 | 0.1694 | 29.84 | -25.15 | 54.99 | 20.04 | 9.78 | 0.02 | NEUTRAL | Average |
| 4 | 0.1694 | 43.13 | -21.86 | 64.99 | 33.33 | 9.78 | 0.02 | NEUTRAL | QP |
| 5 | 0.1904 | 19.96 | -34.06 | 54.02 | 10.15 | 9.79 | 0.02 | NEUTRAL | Average |
| 6 | 0.1904 | 36.64 | -27.38 | 64.02 | 26.83 | 9.79 | 0.02 | NEUTRAL | QP |
| 7 | 0.2701 | 22.10 | -29.02 | 51.12 | 12.28 | 9.79 | 0.03 | NEUTRAL | Average |
| 8 | 0.2701 | 35.20 | -25.92 | 61.12 | 25.38 | 9.79 | 0.03 | NEUTRAL | QP |
| 9 | 0.4444 | 20.24 | -26.74 | 46.98 | 10.41 | 9.79 | 0.04 | NEUTRAL | Average |
| 10 | 0.4444 | 31.94 | -25.04 | 56.98 | 22.11 | 9.79 | 0.04 | NEUTRAL | QP |
| 11 | 13.3372 | 23.69 | -26.31 | 50.00 | 13.36 | 10.08 | 0.25 | NEUTRAL | Average |
| 12 | 13.3372 | 29.30 | -30.70 | 60.00 | 18.97 | 10.08 | 0.25 | NEUTRAL | QP |

Note:

Level = Read Level + LISN Factor + Cable Loss.

4.2. Radiated Emissions Measurement

4.2.1. Limit

30dBc in any 100 kHz bandwidth outside the operating frequency band. In case the emission fall within the restricted band specified on 15.205(a), then the 15.209(a) limit in the table below has to be followed.

| Frequencies (MHz) | Field Strength (micorvolts/meter) | Measurement Distance (meters) |
|-------------------|-----------------------------------|-------------------------------|
| 0.009~0.490 | 2400/F(kHz) | 300 |
| 0.490~1.705 | 24000/F(kHz) | 30 |
| 1.705~30.0 | 30 | 30 |
| 30~88 | 100 | 3 |
| 88~216 | 150 | 3 |
| 216~960 | 200 | 3 |
| Above 960 | 500 | 3 |

4.2.2. Measuring Instruments and Setting

Please refer to section 5 of equipments list in this report. The following table is the setting of spectrum analyzer and receiver.

| Spectrum Parameter | Setting |
|---|---|
| Attenuation | Auto |
| Start Frequency | 1000 MHz |
| Stop Frequency | 10th carrier harmonic |
| RBW / VBW (Emission in restricted band) | 1MHz / 3MHz for Peak, 1MHz / 1/T for Average |
| RBW / VBW (Emission in non-restricted band) | 100kHz / 300kHz for peak |

| Receiver Parameter | Setting |
|------------------------|-----------------------------------|
| Attenuation | Auto |
| Start ~ Stop Frequency | 9kHz~150kHz / RBW 200Hz for QP |
| Start ~ Stop Frequency | 150kHz~30MHz / RBW 9kHz for QP |
| Start ~ Stop Frequency | 30MHz~1000MHz / RBW 120kHz for QP |

4.2.3. Test Procedures

1. Configure the EUT according to ANSI C63.10. The EUT was placed on the top of the turntable 0.8 meter above ground. The phase center of the receiving antenna mounted on the top of a height-variable antenna tower was placed 1m & 3m far away from the turntable.
2. Power on the EUT and all the supporting units. The turntable was rotated by 360 degrees to determine the position of the highest radiation.
3. The height of the broadband receiving antenna was varied between one meter and four meters above ground to find the maximum emissions field strength of both horizontal and vertical polarization.
4. For each suspected emissions, the antenna tower was scan (from 1 m to 4 m) and then the turntable was rotated (from 0 degree to 360 degrees) to find the maximum reading.
5. Set the test-receiver system to Peak or CISPR quasi-peak Detect Function with specified bandwidth under Maximum Hold Mode.
6. For emissions above 1GHz, use 1MHz VBW and 3MHz RBW for peak reading. Then 1MHz RBW and 1/T VBW for average reading in spectrum analyzer.
7. If the emissions level of the EUT in peak mode was 3 dB lower than the average limit specified, then testing will be stopped and peak values of EUT will be reported, otherwise, the emissions which do not have 3 dB margin will be repeated one by one using the quasi-peak method for below 1GHz.
8. For testing above 1GHz, the emissions level of the EUT in peak mode was lower than average limit (that means the emissions level in peak mode also complies with the limit in average mode), then testing will be stopped and peak values of EUT will be reported, otherwise, the emissions will be measured in average mode again and reported.
9. In case the emission is lower than 30MHz, loop antenna has to be used for measurement and the recorded data should be QP measured by receiver. High – Low scan is not required in this case.

4.2.4. Test Setup Layout

For Radiated Emissions: 9kHz ~30MHz

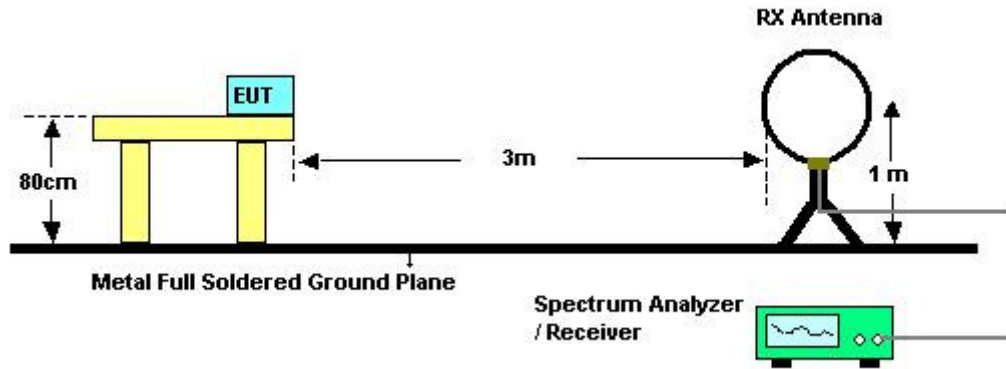

For Radiated Emissions: 30MHz~1GHz

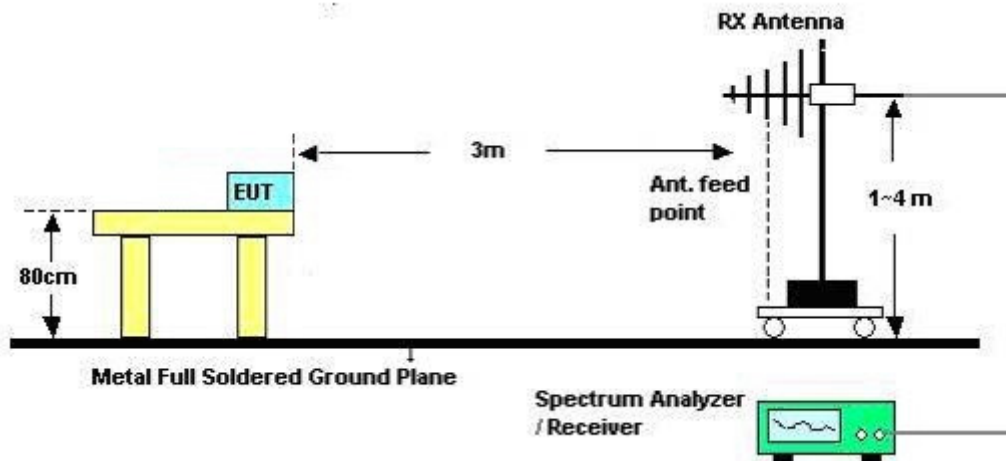

4.2.5. Test Deviation

There is no deviation with the original standard.

4.2.6. EUT Operation during Test

The EUT was programmed to be in continuously transmitting mode.

4.2.7. Results of Radiated Emissions (9kHz~30MHz)

| | | | |
|----------------------|---------------|-----------------------|-------------|
| Temperature | 22°C | Humidity | 55% |
| Test Engineer | Stim Sung | Configurations | Normal Link |
| Test Date | Nov. 30, 2015 | | |

| Freq. (MHz) | Level (dBuV) | Over Limit (dB) | Limit Line (dBuV) | Remark |
|--------------------|---------------------|------------------------|--------------------------|---------------|
| - | - | - | - | See Note |

Note:

The amplitude of spurious emissions which are attenuated by more than 20 dB below the permissible value has no need to be reported.

Distance extrapolation factor = $40 \log(\text{specific distance} / \text{test distance})$ (dB);

Limit line = specific limits (dBuV) + distance extrapolation factor.

4.2.8. Results of Radiated Emissions (30MHz~1GHz)

| | | | |
|---------------|-----------|----------------|-------------|
| Temperature | 22°C | Humidity | 55% |
| Test Engineer | Stim Sung | Configurations | Normal Link |

Horizontal

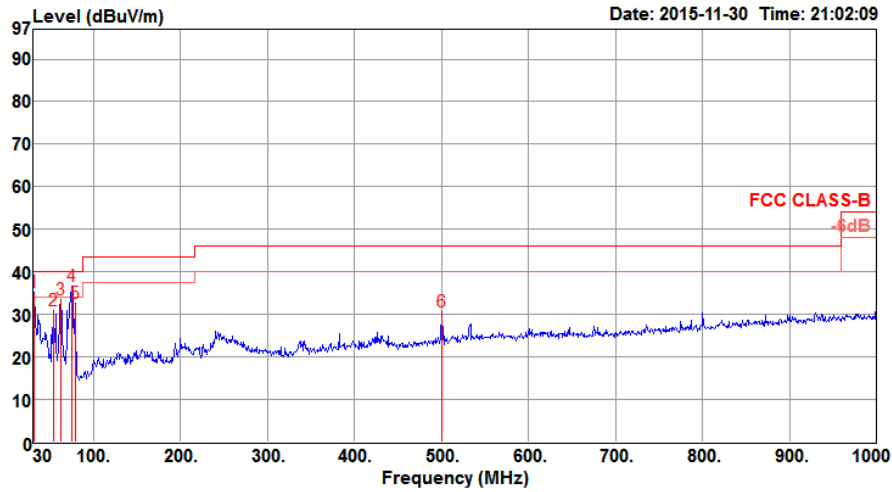

| | Freq | Level | Limit | Over | Read | Cable | Antenna | Preamp | Remark | A/Pos | T/Pos | Pol/Phase |
|---|--------|--------|--------|--------|-------|-------|---------|--------|--------|-------|-------|------------|
| | MHz | dBuV/m | dBuV/m | dB | dBuV | dB | dB/m | dB | | cm | deg | |
| 1 | 31.94 | 35.31 | 40.00 | -4.69 | 43.66 | 1.23 | 18.91 | 28.49 | Peak | 400 | 360 | HORIZONTAL |
| 2 | 53.28 | 30.97 | 40.00 | -9.03 | 49.67 | 1.35 | 8.40 | 28.45 | Peak | 400 | 360 | HORIZONTAL |
| 3 | 62.01 | 33.54 | 40.00 | -6.46 | 53.66 | 1.41 | 6.88 | 28.41 | Peak | 400 | 360 | HORIZONTAL |
| 4 | 74.62 | 36.57 | 40.00 | -3.43 | 56.28 | 1.48 | 7.18 | 28.37 | Peak | 400 | 360 | HORIZONTAL |
| 5 | 78.50 | 32.69 | 40.00 | -7.31 | 52.07 | 1.50 | 7.47 | 28.35 | Peak | 400 | 360 | HORIZONTAL |
| 6 | 500.45 | 30.65 | 46.00 | -15.35 | 38.91 | 2.58 | 17.84 | 28.68 | Peak | 400 | 360 | HORIZONTAL |

Vertical

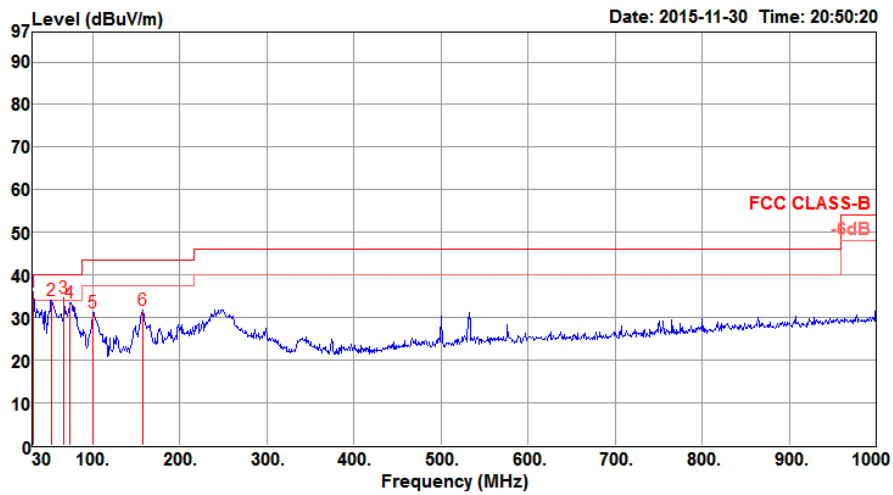

| | Freq | Level | Limit | Over | Read | CableAntenna | Preamp | | A/Pos | T/Pos | |
|---|--------|--------|--------|--------|-------|--------------|--------|-------|-------|-------|-----------|
| | MHz | dBuV/m | dBuV/m | dB | dBuV | dB | dB/m | dB | cm | deg | Pol/Phase |
| 1 | 31.94 | 35.98 | 40.00 | -4.02 | 44.33 | 1.23 | 18.91 | 28.49 | 400 | 360 | VERTICAL |
| 2 | 52.31 | 34.05 | 40.00 | -5.95 | 52.55 | 1.34 | 8.62 | 28.46 | 400 | 360 | VERTICAL |
| 3 | 66.86 | 34.52 | 40.00 | -5.48 | 54.66 | 1.43 | 6.83 | 28.40 | 400 | 360 | VERTICAL |
| 4 | 73.65 | 33.53 | 40.00 | -6.47 | 53.34 | 1.47 | 7.09 | 28.37 | 400 | 360 | VERTICAL |
| 5 | 99.84 | 31.12 | 43.50 | -12.38 | 46.63 | 1.58 | 11.20 | 28.29 | 400 | 360 | VERTICAL |
| 6 | 157.07 | 31.78 | 43.50 | -11.72 | 47.10 | 1.69 | 10.91 | 27.92 | 400 | 360 | VERTICAL |

Note:

The amplitude of spurious emissions that are attenuated by more than 20dB below the permissible value has no need to be reported.

Emission level (dBuV/m) = 20 log Emission level (uV/m).

Corrected Reading: Antenna Factor + Cable Loss + Read Level - Preamp Factor = Level.

4.3. Antenna Requirements

4.3.1. Limit

Except for special regulations, the Low-power Radio-frequency Devices must not be equipped with any jacket for installing an antenna with extension cable. An intentional radiator shall be designed to ensure that no antenna other than that furnished by the responsible party shall be used with the device. The use of a permanently attached antenna or of an antenna that uses a unique coupling to the intentional radiator shall be considered sufficient to comply with the provisions of this Section. The manufacturer may design the unit so that the user can replace a broken antenna, but the use of a standard antenna jack or electrical connector is prohibited. Further, this requirement does not apply to intentional radiators that must be professionally installed.

4.3.2. Antenna Connector Construction

Please refer to section 3.3 in this test report; antenna connector complied with the requirements.

5. LIST OF MEASURING EQUIPMENTS

| Instrument | Manufacturer | Model No. | Serial No. | Characteristics | Calibration Date | Remark |
|-------------------|--------------|------------------|------------|-----------------|------------------|-----------------------|
| EMI Test Receiver | R&S | ESCS 30 | 100355 | 9kHz ~ 2.75GHz | Apr. 22, 2015 | Conduction (CO01-CB) |
| LISN | F.C.C. | FCC-LISN-50-16-2 | 04083 | 150kHz ~ 100MHz | Dec. 02, 2014 | Conduction (CO01-CB) |
| LISN | Schwarzbeck | NSLK 8127 | 8127647 | 9kHz ~ 30MHz | Dec. 02, 2014 | Conduction (CO01-CB) |
| COND Cable | Woken | Cable | 01 | 150kHz ~ 30MHz | Dec. 03, 2014 | Conduction (CO01-CB) |
| Software | Audix | E3 | 6.120210n | - | N.C.R. | Conduction (CO01-CB) |
| BILOG ANTENNA | Schaffner | CBL6112D | 37880 | 20MHz ~ 2GHz | Sep 03, 2015 | Radiation (03CH01-CB) |
| Pre-Amplifier | Agilent | 8447D | 2944A10991 | 0.1MHz ~ 1.3GHz | Feb. 24, 2015 | Radiation (03CH01-CB) |
| Spectrum Analyzer | R&S | FSP40 | 100056 | 9kHz ~ 40GHz | Oct. 27, 2015 | Radiation (03CH01-CB) |
| EMI Receiver | Agilent | N9038A | MY52260123 | 9kHz ~ 8.4GHz | Jan. 21, 2015 | Radiation (03CH01-CB) |
| RF Cable-low | Woken | Low Cable-1 | N/A | 30 MHz ~ 1 GHz | Nov. 02, 2015 | Radiation (03CH01-CB) |
| Loop Antenna | Teseq | HLA 6120 | 24155 | 9kHz - 30 MHz | Mar. 12, 2015* | Radiation (10CH01-CB) |

Note: Calibration Interval of instruments listed above is one year.

“*” Calibration Interval of instruments listed above is two years.

N.C.R. means Non-Calibration required.

6. MEASUREMENT UNCERTAINTY

| Test Items | Uncertainty | Remark |
|--------------------------------------|-------------|--------------------------|
| Conducted Emission (150kHz ~ 30MHz) | 3.2 dB | Confidence levels of 95% |
| Radiated Emission (30MHz ~ 1,000MHz) | 3.6 dB | Confidence levels of 95% |