

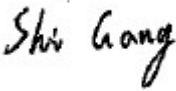
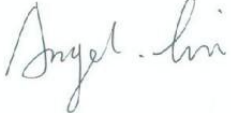
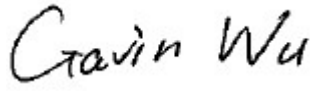

TEST REPORT

Report No.: EM201100506-1	Application No.: ZJ00012332	
Client: AirTies Wireless Networks		
Address: Gulbahar Mah. Avni Dilligil sk. No:5 Celik Is Merkezi Mecidiyekoy Istanbul, Turkey		
Sample Description: 300 Mbps 802.11n Wireless USB Adapter		
Model: Air 2411		
Test Location: Guangzhou GRG Metrology and Test Co., Ltd.		
Test Specification: FCC Part 15 Subpart E (Section 15.407)		
Issue Date: 2012-01-17		
Test Result: Pass.		
Prepared By:	Reviewed By:	Approved By:
Shi Gang / Test Engineer	Angel Liu / Technical Assistance	Gavin Wu / Manager
		
Date:2012-01-17	Date:2012-01-17	Date:2012-01-17
Other Aspects:		
<p>Abbreviations: ok / P = passed; fail / F = failed; n.a. / N = not applicable</p> <p>The test result in this test report refers exclusively to the presented test sample. This report shall not be reproduced except in full, without the written approval of GRGT.</p>		

GRG Metrology and Test Co., Ltd.

Address: 163, Pingyun Road, West of Huangpu Avenue, Guangzhou, Guangdong, P.R. China

Tel:+86-20-38699960

Fax:+86-20-38695185

Email: cert-center@grg.net.cn<http://www.grgtest.com>

Ver.:1.0 / 01.Jan.2011

DIRECTIONS OF TEST

1. This station carries out test task according to the national regulation of verifications which can be traced to National Primary Standards and BIPM.
2. The test report merely corresponds to the test sample. It is not permitted to copy extracts of these test result without the written permission of the test laboratory.
3. If there is any objection concerning the test, the client should inform the laboratory within 15 days from the date of receiving the test report.

Table of Contents

1. TEST RESULT SUMMARY.....	5
2. GENERAL DESCRIPTION OF EUT	6
2.1 APPLICANT	6
2.2 MANUFACTURER	6
2.3 BASIC DESCRIPTION OF EQUIPMENT UNDER TEST	6
2.4 TEST OPERATION MODES	6
2.5 LOCAL SUPPORTIVE INSTRUMENTS	6
3. LABORATORY AND ACCREDITATIONS.....	7
3.1 LABORATORY	7
3.2 ACCREDITATIONS.....	7
3.3 MEASUREMENT UNCERTAINTY	7
3.4 LIST OF USED TEST EQUIPMENT AT GRGT	8
4. ANTENNA REQUIREMENT	9
5. AC POWER LINE CONDUCTED EMISSION MEASUREMENT	10
5.1 LIMITS.....	10
5.2 TEST PROCEDURES.....	10
5.3 TEST SETUP	11
5.4 TEST RESULTS	12
6. 26DB BANDWIDTH MEASUREMENT	14
6.1 LIMITS.....	14
6.2 TEST PROCEDURES.....	14
6.3 TEST SETUP	14
6.4 TEST RESULTS	14
7. MAXIMUM CONDUCTED OUTPUT POWER.....	18
7.1 LIMITS.....	18
7.2 TEST PROCEDURES.....	18
7.3 TEST SETUP	18
7.4 TEST RESULTS	19
8. POWER SPECTRAL DENSITY	24
8.1 LIMITS.....	24
8.2 TEST PROCEDURES.....	24
8.3 TEST SETUP	24
8.4 TEST RESULTS	25
9. PEAK EXCURSION MEASUREMENT	28
9.1 LIMITS.....	28
9.2 TEST PROCEDURES.....	28
9.3 TEST SETUP	28
9.4 TEST RESULTS	29
9. FREQUENCY STABILITY	33
9.1 LIMITS.....	33
9.2 Method of Measurements.....	33
9.3 Test Arrangement.....	33
9.4 Test result.....	33
10 CONDUCTED SPURIOUS EMISSIONS	34
10.1 LIMITS.....	34
10.2 TEST PROCEDURES.....	34
10.3 TEST SETUP	34
10.4 TEST RESULTS	34

11. RADIATED SPURIOUS EMISSIONS..... 43

11.1 LIMITS..... 43

11.2 TEST PROCEDURES..... 43

11.3 TEST SETUP 44

11.4 HARMONIC AND OTHER SPURIOUS EMISSIONS 46

11.5 RADIATED EMISSIONS WHICH FALL IN THE RESTRICTED BANDS..... 50

11.5.1 LIMITS..... 50

11.5.2 TEST RESULT 51

12. BAND EDGE 52

12.1 LIMITS..... 52

12.2 TEST PROCEDURES..... 52

12.3 TEST SETUP 52

12.4 TEST RESULTS 53

APPENDIX A: PHOTOGRAPH OF THE TEST ARRANGEMENT..... 55

APPENDIX B: PHOTOGRAPH OF THE EUT..... 57

1. TEST RESULT SUMMARY

Section B of FCC Part 15.407:2010			
Standard	Test Item	Limit / Severity	Result
FCC Part 15 Subpart E (15.407)	AC Power Line Conducted Emissions	§15.207	PASS
	26dB Spectrum Bandwidth	§15.407 (a)	PASS
	Maximun Conducted Output Power	§15.407 (a)	PASS
	Power Spectral Density	§15.407 (a)	PASS
	Frequency Stability	§15.407 (g)	PASS
	Peak Excursion	§15.407 (a)	PASS
	Radiated Emissions Below 1GHz	§15.407 (b)	PASS
	Radiated Emissions Above 1GHz	§15.407 (b)	PASS
	Band Edge Emissions	§15.407 (b)	PASS
	Antenna Requirements	§15.203	PASS

2. GENERAL DESCRIPTION OF EUT

2.1 APPLICANT

Name: AirTies Wireless Networks
Address: Gulbahar Mah. Avni Dilligil sk. No:5 Celik Is Merkezi Mecidiyekoy Istanbul, Turkey

2.2 MANUFACTURER

Name: Shenzhen Gongjin Electronics Co., Ltd
Address: B116, B118, A211-A213, B201-B213, A311-313 and B411-413, Nanshan Medical Instrument Industry Park, 1019# Nanhai RD, Shenzhen, Guangdong, China

2.3 BASIC DESCRIPTION OF EQUIPMENT UNDER TEST

Equipment: 300 Mbps 802.11n Wireless USB Adapter
Model No.: Air 2411
Adding Model /
Trade Name: AirTies
Frequency Range 5180MHz~5240MHz: 802.11n;
Channels Number: 4 for 20MHz bandwidth; 2 for 40MHz bandwidth
Type of emission WIFI
Note: /

2.4 TEST OPERATION MODES

Test mode: Test the EUT in lowest, middle and highest channels with continue transmitting mode.

2.5 LOCAL SUPPORTIVE INSTRUMENTS

Name of Equipment	Manufacturer	Model	Serial Number
PC	Lenovo	E46L	EB22867264

3. LABORATORY AND ACCREDITATIONS

3.1 LABORATORY

The tests and measurements refer to this report were performed by Guangzhou GRG Metrology and Test CO., LTD.

Add. : 163 Pingyun Rd, West of Huangpu Ave, Guangzhou, 510656, P. R. China

Telephone: +86-20-38699959, 38699960, 38699961

Fax : +86-20-38695185

3.2 ACCREDITATIONS

Our laboratories are accredited and approved by the following approval agencies according to ISO/IEC 17025.

USA	FCC Listed Lab (No. 688188)
China	CNAS (No.L0446)
China	DILAC (No.DL175)
Canada	Registration No.:8355A-1

3.3 MEASUREMENT UNCERTAINTY

Where relevant, the following measurement uncertainty levels have been estimated for tests performed on the EUT as specified in CISPR 16-4-2:

Measurement		Frequency	Uncertainty
Radiated Emission	Horizontal	30MHz~1000MHz	4.2dB
		1GHz~26.5GHz	4.2dB
	Vertical	30MHz~1000MHz	4.4dB
		1GHz~26.5GHz	4.4dB
Conducted Emission		9kHz~30MHz	3.1 dB

This uncertainty represents an expanded uncertainty factor of $k=2$.

3.4 LIST OF USED TEST EQUIPMENT AT GRGT

Name of Equipment	Manufacturer	Model	Serial Number	Calibration Due
Conducted Emissions				
EMI Receiver	R&S	ESCI	100529	2012-06-16
L.I.S.N	SCHWARZBECK	NSLK 8127	8127450	2012-08-21
Spurious Emissions at Antenna Port				
Receiver	R&S	ESU40	100106	2012-09-26
Restricted Bands				
Receiver	R&S	ESU40	100106	2012-09-26
Spurious Emissions				
Receiver	R&S	ESU40	100106	2012-09-26
Receiver	R&S	ESU40	100106	2012-06-09
Loop Antenna	ROHDE & SCHWARZ	HFH2-Z2	881058/28	2012-7-7
Biconical log-periodic antenna	ETS.LINDGREN	3142 C	00075971	2012-7-31
Horn antenna	SCHWARZBECK	BBHA9120D	D752	2013-10-14
26 dB Bandwidth				
Receiver	R&S	ESU40	100106	2012-09-26
Maximum Peak Output Power				
Receiver	R&S	ESU40	100106	2012-06-09
Band Edge				
Receiver	R&S	ESU40	100106	2012-09-26
Frequency Stability				
Receiver	R&S	ESU40	100106	2012-09-26
Constant temperature&mimidity chamber	CEPREI	CEEC-MSJ-60BE	11015	2012-05-15

4. ANTENNA REQUIREMENT

The EUT antenna is PCB Printed antenna. Antenna gain is 0 dBi .which accordance 15.407.is considered sufficient to comply with the provisions of this section

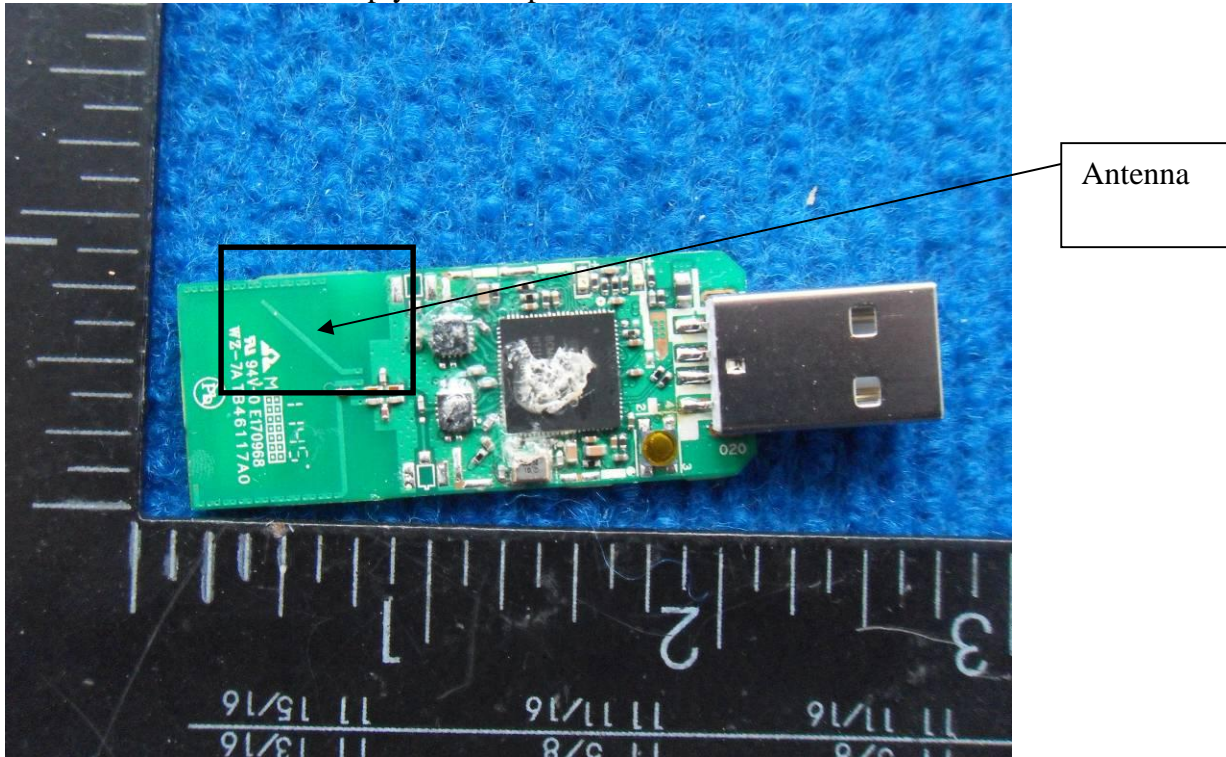

Test result: The unit does meet the FCC requirements.

5. AC POWER LINE CONDUCTED EMISSION MEASUREMENT

5.1 LIMITS

Frequency range	Limits (dB μ V)	
	Quasi-peak	Average
150kHz ~ 0.5MHz	66~56	56~46
0.5 MHz ~ 5 MHz	56	46
5 MHz ~ 30 MHz	60	50

NOTE: (1) The lower limit shall apply at the transition frequencies.

(2) The limit decreases in line with the logarithm of the frequency in the range of 150 kHz to 0.5MHz.

5.2 TEST PROCEDURES

Procedure of Preliminary Test

For measurement of the disturbance voltage the equipment under test (EUT) is connected to the power supply mains and any other extended network via one or more artificial network(s). An EUT, whether intended to be grounded or not, and which is to be used on a table is configured as follows:

- Either the bottom or the rear of the EUT shall be at a controlled distance of 40 cm from a reference ground plane. This ground plane is normally the wall or floor of a shielded room. It may also be a grounded metal plane of at least 2 m by 2 m. This is physically accomplished as follows:
 - 1) place the EUT on a table of non-conducting material which is at least 80 cm high. Place the EUT so that it is 40 cm from the wall of the shielded room, or
 - 2) place the EUT on a table of non-conducting material which is 40 cm high so that the bottom of the EUT is 40 cm above the ground plane;
- All other conductive surfaces of the EUT shall be at least 80 cm from the reference ground plane;
- The EUT are placed on the floor that one side of the housings is 40 cm from the vertical reference ground plane and other metallic parts;
- Interconnecting cables that hang closer than 40 cm to the ground plane shall be folded back and forth forming a bundle 30 cm to 40 cm long, hanging approximately in the middle between the ground plane and the table.
- I/O cables that are connected to a peripheral shall be bundled in the centre. The end of the cable may be terminated if required using correct terminating impedance. The total length shall not exceed 1 m.

The test mode(s) described in Item 2.4 were scanned during the preliminary test. After the preliminary scan, we found the test mode described in Item 2.4 producing the highest emission level. The EUT configuration and cable configuration of the above highest emission levels were recorded for reference of the final test.

Procedure of Final Test

EUT and support equipment were set up on the test bench as per the configuration with

highest emission level in the preliminary test. A scan was taken on both power lines, recording at least the six highest emissions. Emission frequency and amplitude were recorded into a computer in which correction factors were used to calculate the emission level and compare reading to the applicable limit. The test data of the worst-case condition(s) was recorded.

5.3 TEST SETUP

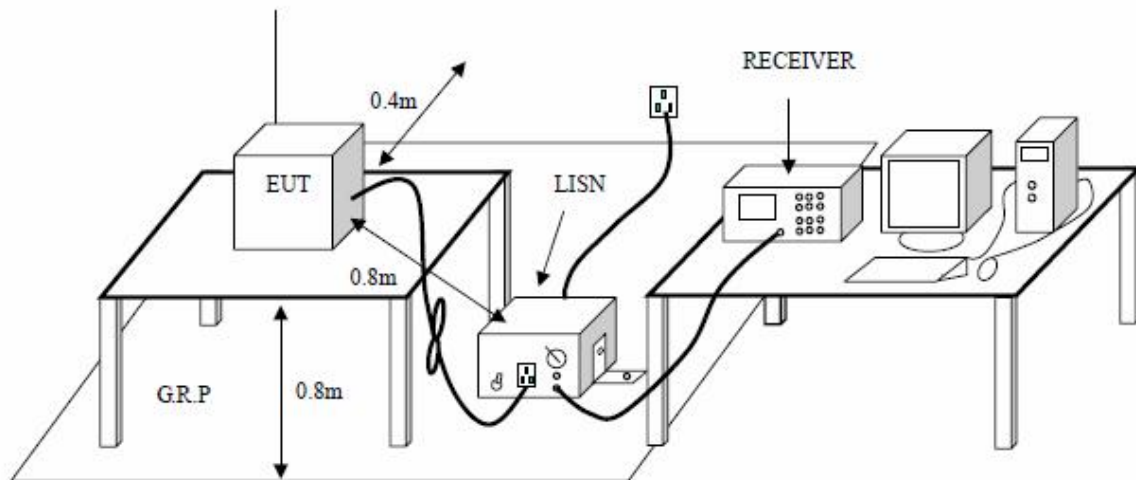

5.4 TEST RESULTS

Test Result:	Pass	Probe:	L1
Standard:	(CE)FCC PART 15 class B_QP	Power Source:	AC 120V/60Hz
Test item:	Conduction Test	Date:	2012-1-9
Temp./Hum.(%RH):	25/57%RH	Time:	14:35:32
EUT:	300 Mbps 802.11n Wireless USB Adapter	Model:	Air 2411
Note:	Test the EUT in transmitting mode.		

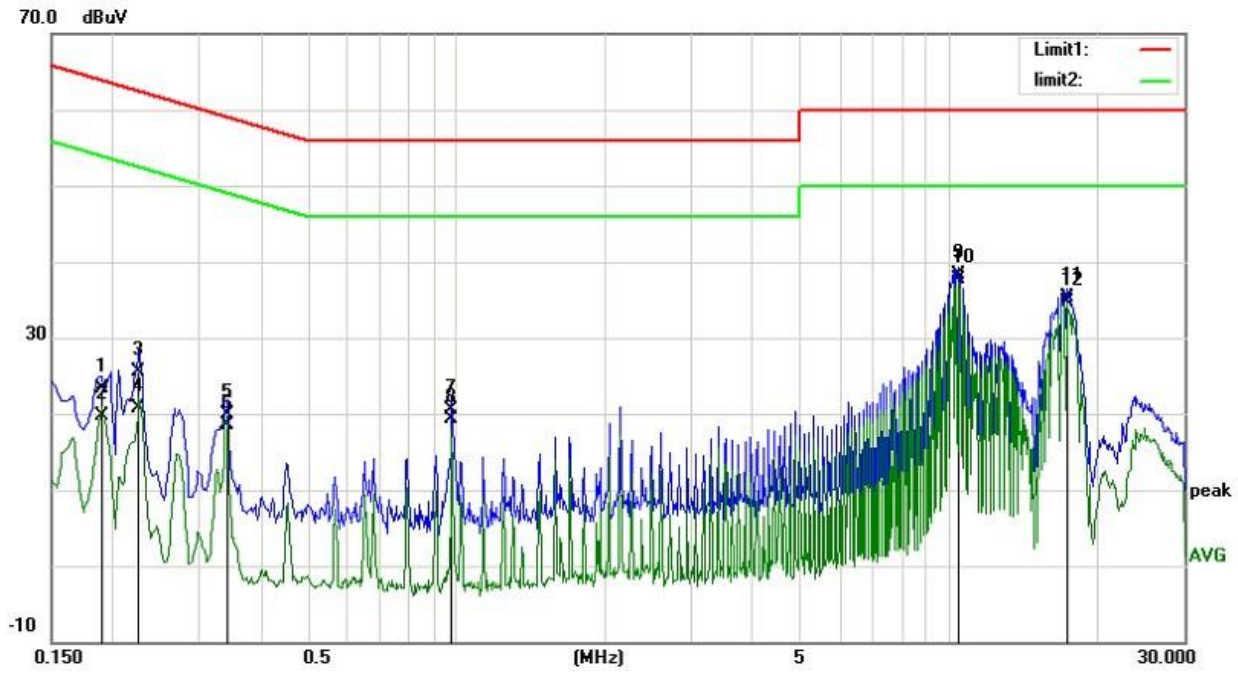

QP and Average measure:

No.	Mk.	Freq. MHz	Reading Level dBuV	Correct Factor dB	Measure- ment dBuV	Limit dBuV	Over dB	Detector	Comment
1		0.1900	22.12	1.28	23.40	64.03	-40.63	QP	
2		0.1900	18.52	1.28	19.80	54.03	-34.23	AVG	
3		0.2260	24.63	0.97	25.60	62.59	-36.99	QP	
4		0.2260	19.83	0.97	20.80	52.59	-31.79	AVG	
5		0.3420	19.07	0.83	19.90	59.15	-39.25	QP	
6		0.3420	17.77	0.83	18.60	49.15	-30.55	AVG	
7		0.9778	20.09	0.41	20.50	56.00	-35.50	QP	
8		0.9778	18.89	0.41	19.30	46.00	-26.70	AVG	
9		10.4098	37.51	0.79	38.30	60.00	-21.70	QP	
10	*	10.4098	37.01	0.79	37.80	50.00	-12.20	AVG	
11		17.3059	34.23	1.07	35.30	60.00	-24.70	QP	
12		17.3059	33.73	1.07	34.80	50.00	-15.20	AVG	

Test Result:	Pass	Probe:	N
Standard:	(CE)FCC PART 15 class B_QP	Power Source:	AC 120V/60Hz
Test item:	Conduction Test	Date:	2012-1-9
Temp./Hum.(%RH):	25/57%RH	Time:	14:40:38
EUT:	300 Mbps 802.11n Wireless USB Adapter	Model:	Air 2411
Note:	Test the EUT in transmitting mode.		

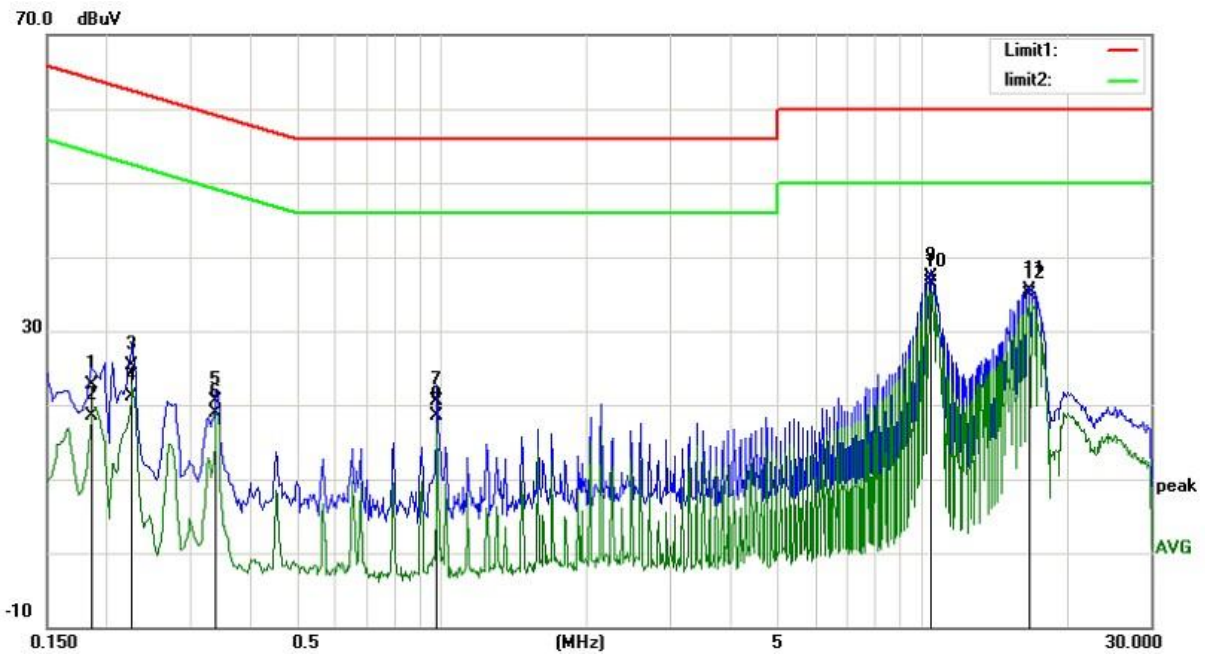

QP and Average measure:

No.	Mk.	Freq. MHz	Reading Level dBuV	Correct Factor dB	Measure- ment dBuV	Limit dBuV	Over dB	Detector	Comment
1		0.1859	21.45	1.35	22.80	64.21	-41.41	QP	
2		0.1859	17.25	1.35	18.60	54.21	-35.61	AVG	
3		0.2260	24.33	0.97	25.30	62.59	-37.29	QP	
4		0.2260	20.13	0.97	21.10	52.59	-31.49	AVG	
5		0.3379	19.66	0.84	20.50	59.25	-38.75	QP	
6		0.3379	18.16	0.84	19.00	49.25	-30.25	AVG	
7		0.9779	20.19	0.41	20.60	56.00	-35.40	QP	
8		0.9779	18.19	0.41	18.60	46.00	-27.40	AVG	
9		10.3978	36.51	0.79	37.30	60.00	-22.70	QP	
10	*	10.3978	35.71	0.79	36.50	50.00	-13.50	AVG	
11		16.8338	34.65	0.95	35.60	60.00	-24.40	QP	
12		16.8338	34.05	0.95	35.00	50.00	-15.00	AVG	

6. 26dB BANDWIDTH MEASUREMENT

6.1 LIMITS

No restriction limits. But resolution bandwidth within band edge measurement is 1% of the 99% occupied bandwidth.

6.2 TEST PROCEDURES

1. Remove the antenna from the EUT and then connect a low RF cable from the antenna port to the spectrum analyzer;
2. Set the spectrum analyzer: RBW=100KHz. VBW = 300KHz. Sweep = auto; Detector Function = Peak. Trace = Max Hold, Set span to encompass the entire emission bandwidth of the signal.
3. Measured the spectrum width with power higher than 26dB below carrier.
4. Repeat until all the test status is investigated.
5. Report the worse case.

6.3 TEST SETUP

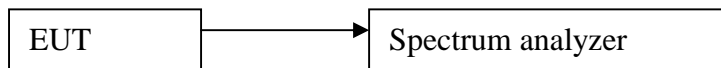

6.4 TEST RESULTS

802.11n mode (HT20):

Channel	Channel Frequency (MHz)	26dB Bandwidth (MHz)
Low Channel	5180	19.6
Middle Channel	5200	19.6
High Channel	5240	20.3

802.11n mode (HT20): Channel 5180MHz

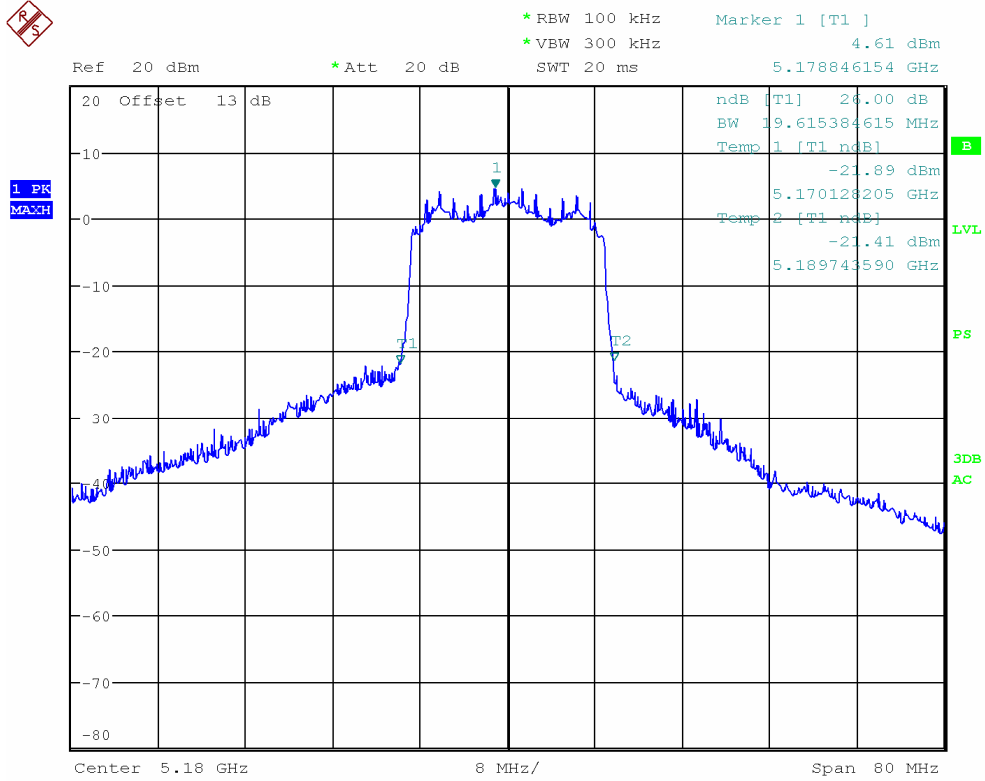

Channel 5200MHz

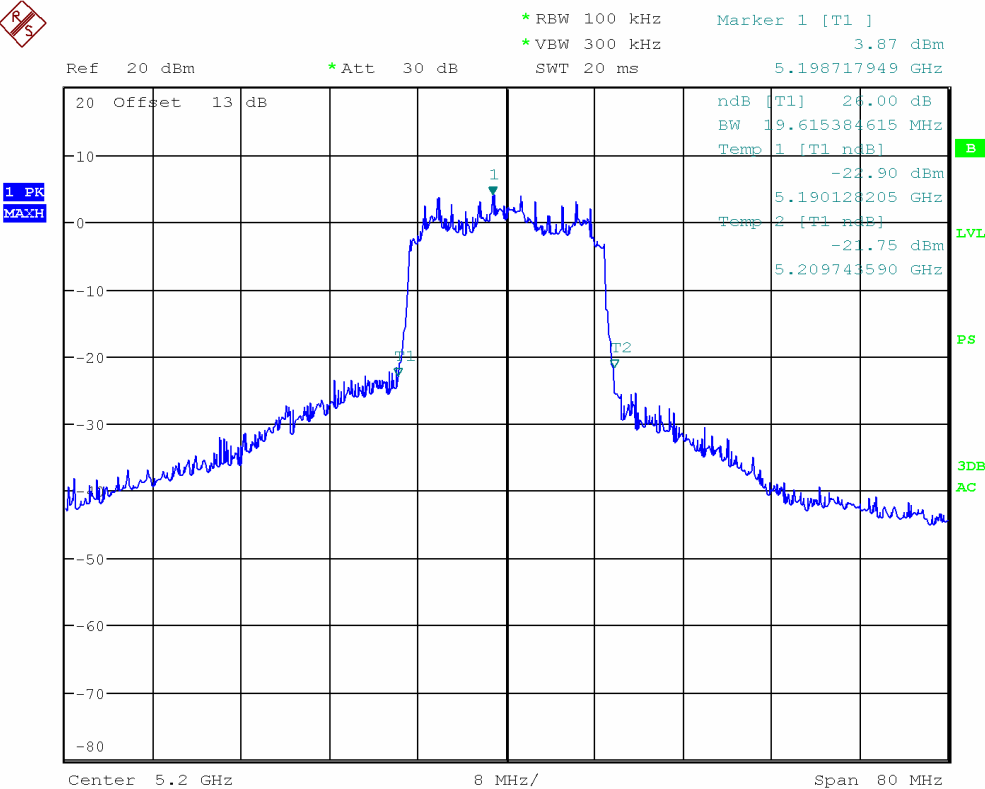

Channel 5240MHz

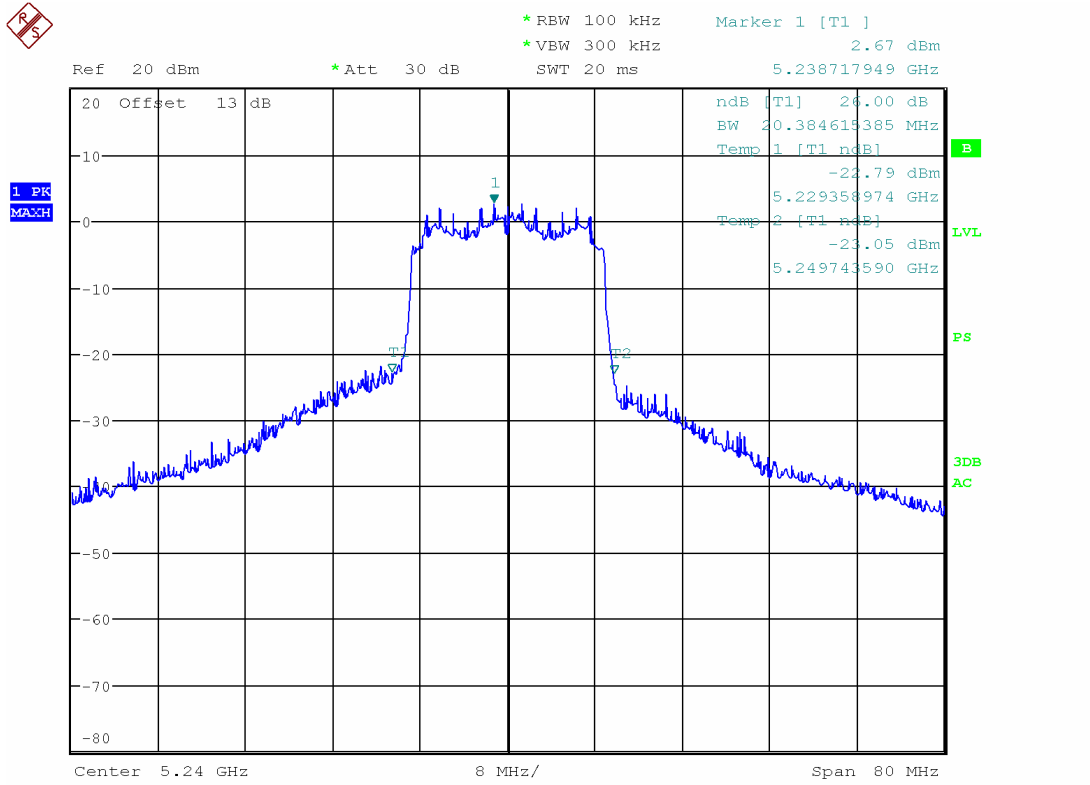

Channel	Channel Frequency (MHz)	26dB Bandwidth (MHz)	99% Occupied Bandwidth (MHz)
Low Channel	5190	40.3	36.2
High Channel	5230	43.6	36.7

802.11a mode (HT40):

Channel 5190MHz

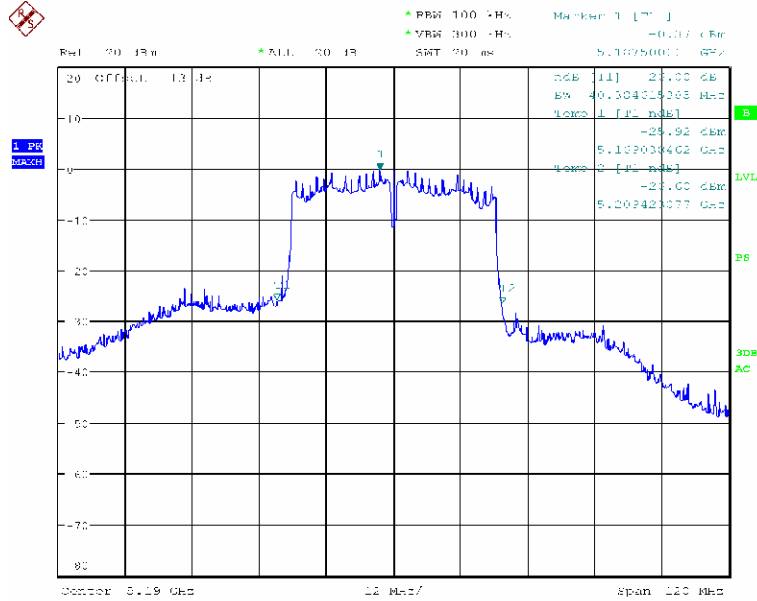

Channel 5230MHz

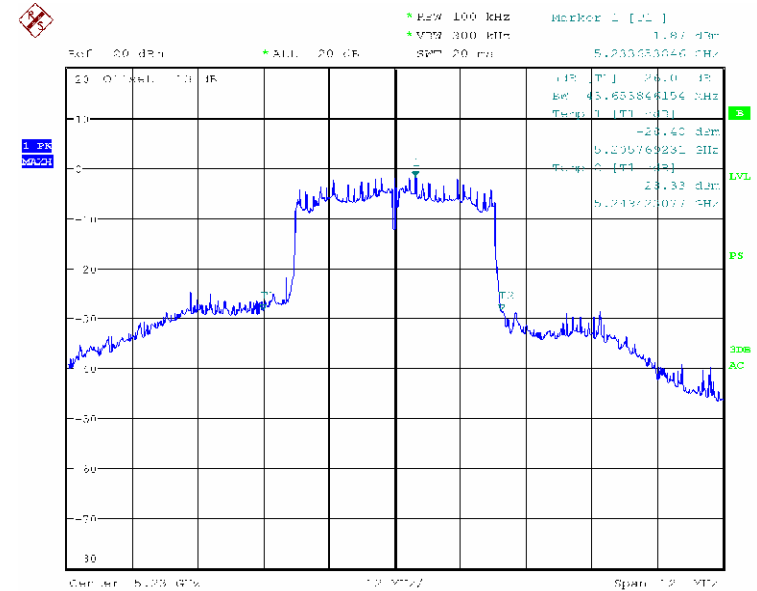

7. MAXIMUM CONDUCTED OUTPUT POWER

7.1 LIMITS

For the band 5.15-5.25 GHz, the maximum conducted output power over the frequency band of operation shall not exceed the lesser of 50mW or $4\text{dBm} + 10\log B$, where B is the 26dB emission bandwidth in MHz.

7.2 TEST PROCEDURES

1. The transmitter output (antenna port) was connected to the spectrum analyzer.
2. Test was performed in accordance with FCC Public Notice DA 02-2138, August 30, 2002.
3. Set the spectrum analyzer: RBW=1000KHz. VBW = 3000KHz. Sweep = auto; Detector Function = RMS. Trace = Max Hold, Set span to encompass the entire emission bandwidth of the signal.
4. When measuring maximum conducted output power with multiple antenna systems, add every result of the values.

7.3 TEST SETUP

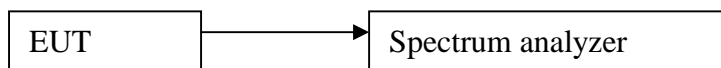

7.4 TEST RESULTS

802.11n (HT20) Mode:

Channel No.	Frequency (MHz)	Mode	Data Rate	Measured Channel Power (dBm)	Limit	Result
36	5180	802.11n (HT20)	MCS7	15.54	50mW (17dBm)	Pass
40	5200			15.13		Pass
48	5240			14.55		Pass
36	5180		MCS6	15.48		Pass
40	5200			15.10		Pass
48	5240			14.49		Pass
36	5180		MCS5	15.47		Pass
40	5200			15.08		Pass
48	5240			14.46		Pass
36	5180		MCS4	15.44		Pass
40	5200			15.05		Pass
48	5240			14.42		Pass
36	5180		MCS3	15.42		Pass
40	5200			15.03		Pass
48	5240			14.39		Pass
36	5180		MCS2	15.40		Pass
40	5200			15.00		Pass
48	5240			14.35		Pass
36	5180		MCS1	15.37		Pass
40	5200			14.97		Pass
48	5240			14.29		Pass
36	5180		MCS0	15.32		Pass
40	5200			14.94		Pass
48	5240			14.26		Pass

802.11n mode (HT20):
Channel 5180MHz

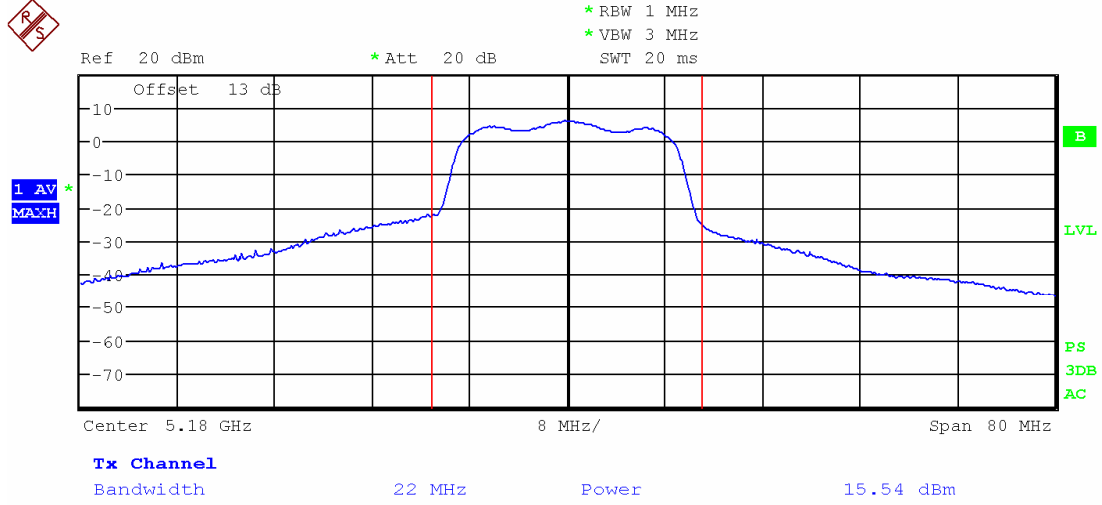

Channel 5200MHz

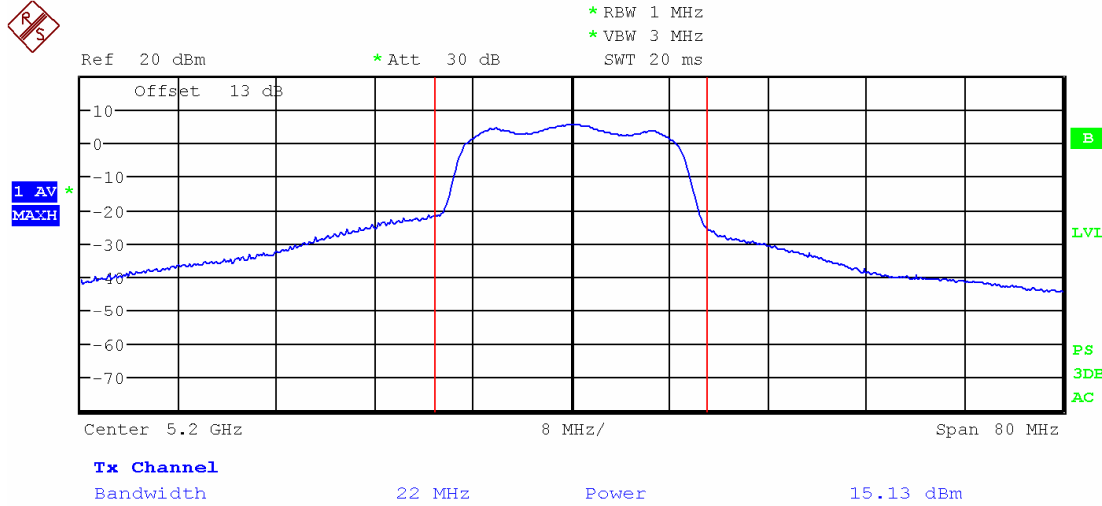

Channel 5240MHz

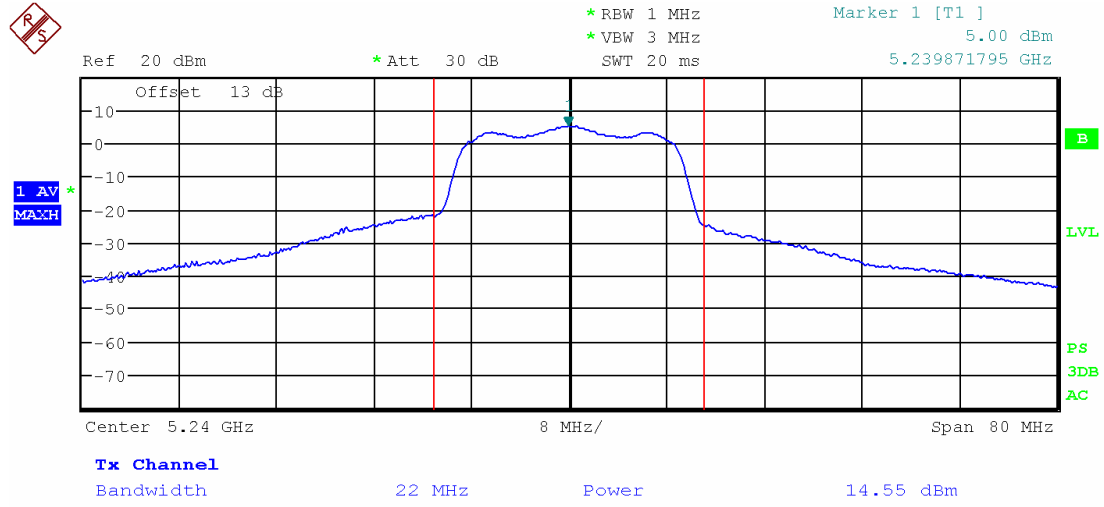

802.11n (HT40) Mode:

Channel No.	Frequency (MHz)	Mode	Data Rate	Measured Channel Power (dBm)	Limit	Result
40	5190	802.11n (HT40)	MCS15	14.12	50mW (17dBm)	Pass
44	5230			14.65		Pass
40	5190		MCS14	14.08		Pass
44	5230			14.64		Pass
40	5190		MCS13	14.03		Pass
44	5230			14.55		Pass
40	5190		MCS12	13.98		Pass
44	5230			14.49		Pass
40	5190		MCS11	13.91		Pass
44	5230			14.40		Pass
40	5190		MCS10	13.85		Pass
44	5230			14.32		Pass
40	5190		MCS9	13.76		Pass
44	5230			14.26		Pass
40	5190		MCS8	13.65		Pass
44	5230			14.18		Pass

802.11n mode (HT40):
Channel 5190MHz

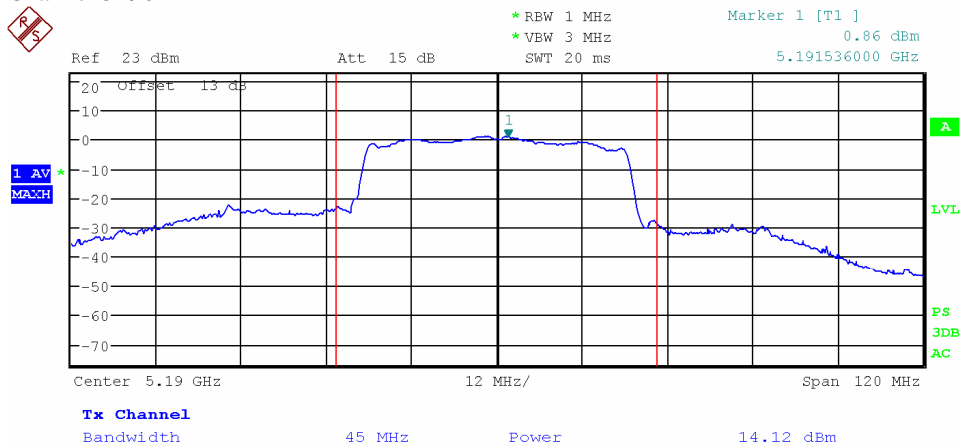

Channel 5230MHz

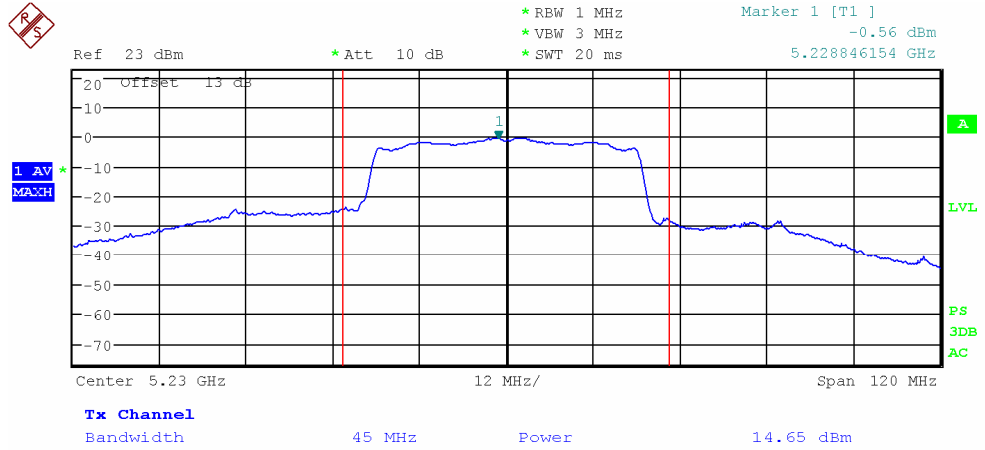

8. POWER SPECTRAL DENSITY

8.1 LIMITS

The peak power spectral density shall not exceed 4dBm in any 1MHz band.

8.2 TEST PROCEDURES

1. Remove the antenna from the EUT and then connect a low RF cable from the antenna port to the spectrum analyzer or power meter.
2. Set the spectrum analyzer: RBW=1MHz. VBW = 3MHz. sweep= (SPAN/1 MHz); Detector Function = Peak. Trace = Max Hold, Centre = the Peak Power of the signal.
3. Measure the Power Spectral Density of the test frequency with special test status.
4. Repeat until all the test status is investigated.
5. Report the worse case.

8.3 TEST SETUP

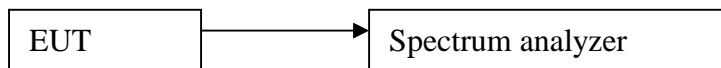

8.4 TEST RESULTS

802.11n Mode (HT20):

Channel No.	Frequency (MHz)	Mode	Measured Channel Power (dBm)	Limit	Result
36	5180	802.11n (HT20)	-0.78	4dBm/1MHz	Pass
40	5200		-0.68		Pass
48	5240		-0.09		Pass

802.11n mode(HT20): Channel 5180MHz

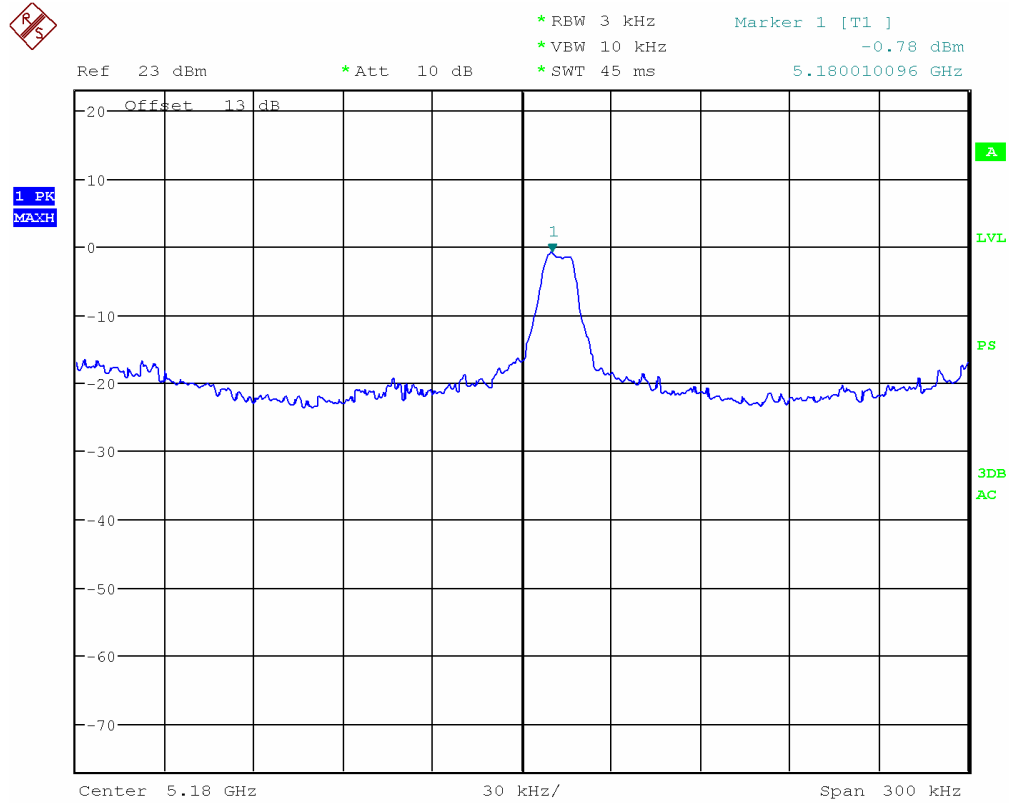

Channel 5200MHz



* RBW 3 kHz Marker 1 [T1]
* VBW 10 kHz 0.68 dBm
SWT 35 ms 5.200032212 GHz

Ref 33 dBm * Att 10 dB

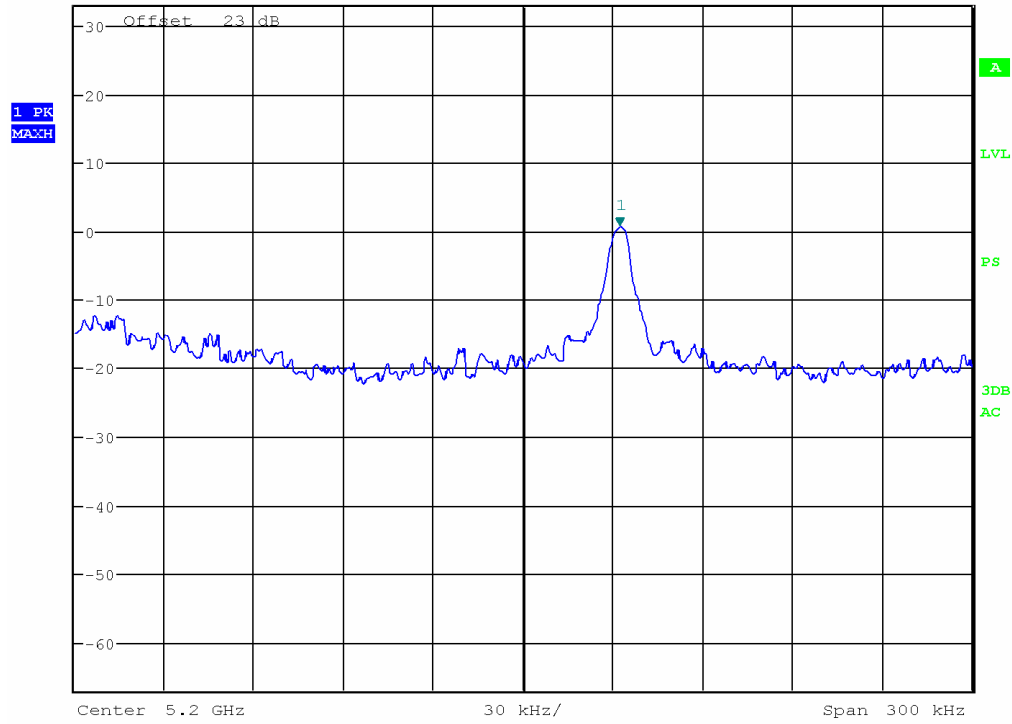

Channel 5240MHz



* RBW 3 kHz Marker 1 [T1]
* VBW 10 kHz -0.09 dBm
SWT 35 ms 5.240013462 GHz

Ref 33 dBm * Att 10 dB

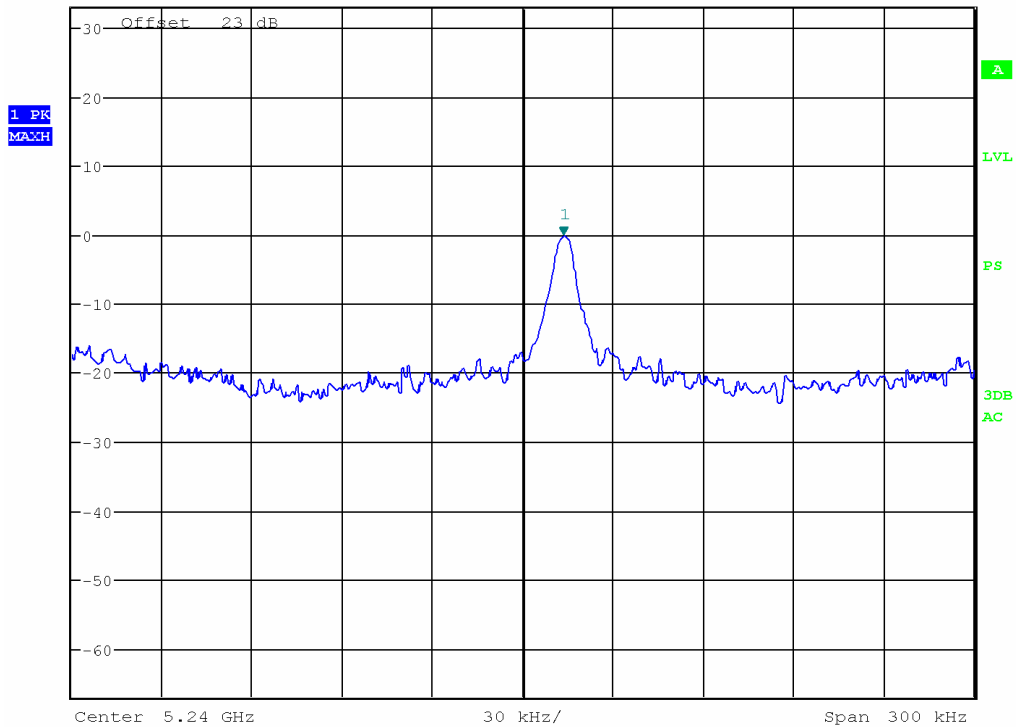

802.11n Mode(HT40):

Channel No.	Frequency (MHz)	Mode	Measured Channel Power (dBm)	Limit	Result
40	5190	802.11n (HT40)	-7.56	4dBm/1MHz	Pass
44	5230		-7.95		Pass

802.11n mode (HT40):
Channel 5190MHz

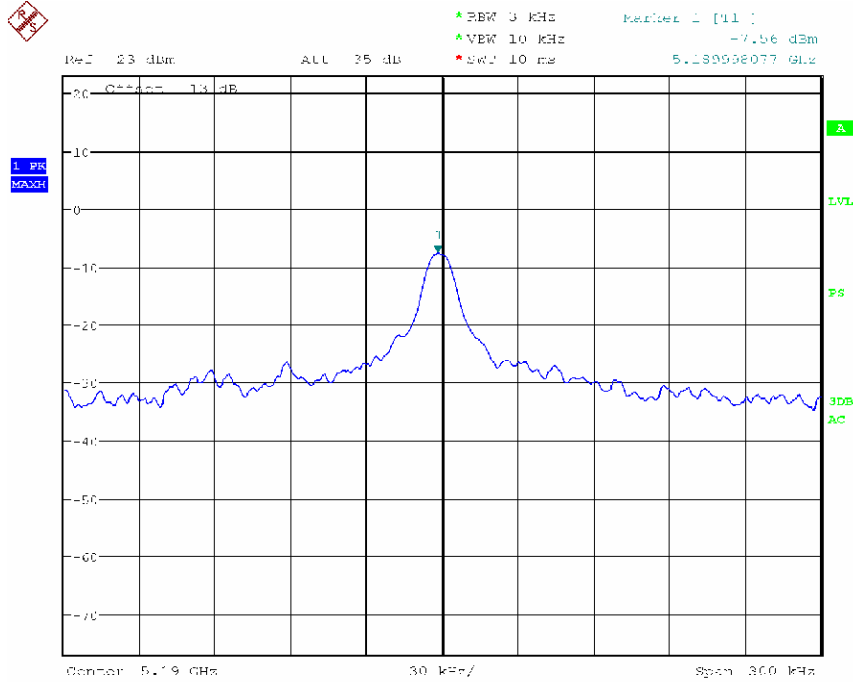

Channel 5230MHz

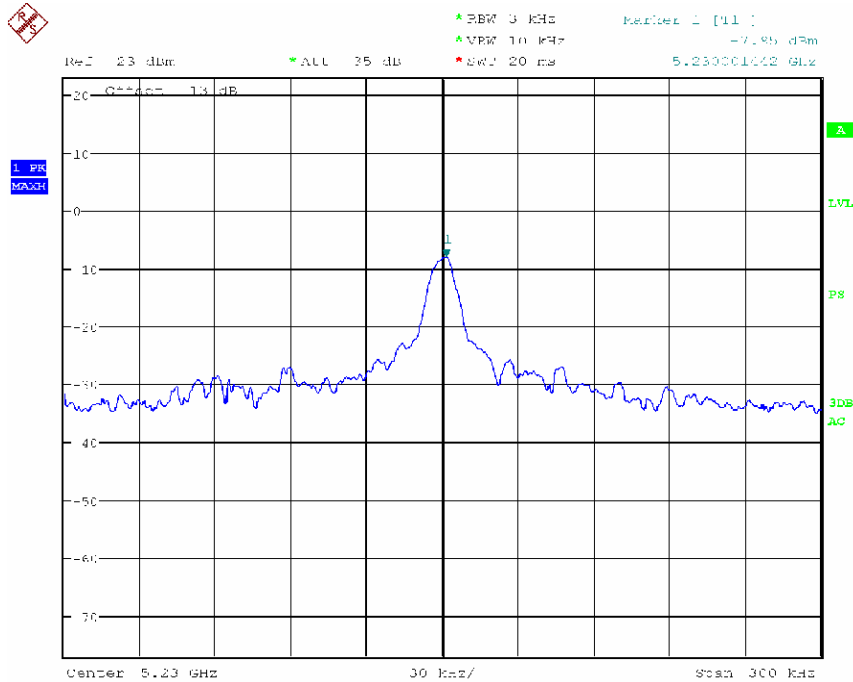

9. PEAK EXCURSION MEASUREMENT

9.1 LIMITS

The peak power spectral density shall not exceed 4dBm in any 1MHz band.

9.2 TEST PROCEDURES

6. Remove the antenna from the EUT and then connect a low RF cable from the antenna port to the spectrum analyzer or power meter.
7. Set the spectrum analyzer: RBW=1MHz. VBW = 3MHz. sweep= (SPAN/1 MHz);
Detector Function = Peak. Trace = Max Hold, Centre = the Peak Power of the signal.
8. Measure the Power Spectral Density of the test frequency with special test status.
9. Repeat until all the test status is investigated.
10. Report the worse case.

9.3 TEST SETUP

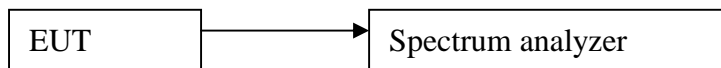

9.4 TEST RESULTS

802.11n Mode (HT20):

Channel No.	Frequency (MHz)	Mode	Measured Channel Power (dB)	Limit (dB)	Result
36	5180	802.11n (HT20)	11.6	13	Pass
40	5200		11.7		Pass
48	5240		11.9		Pass

802.11n mode (HT20): Channel 5180MHz

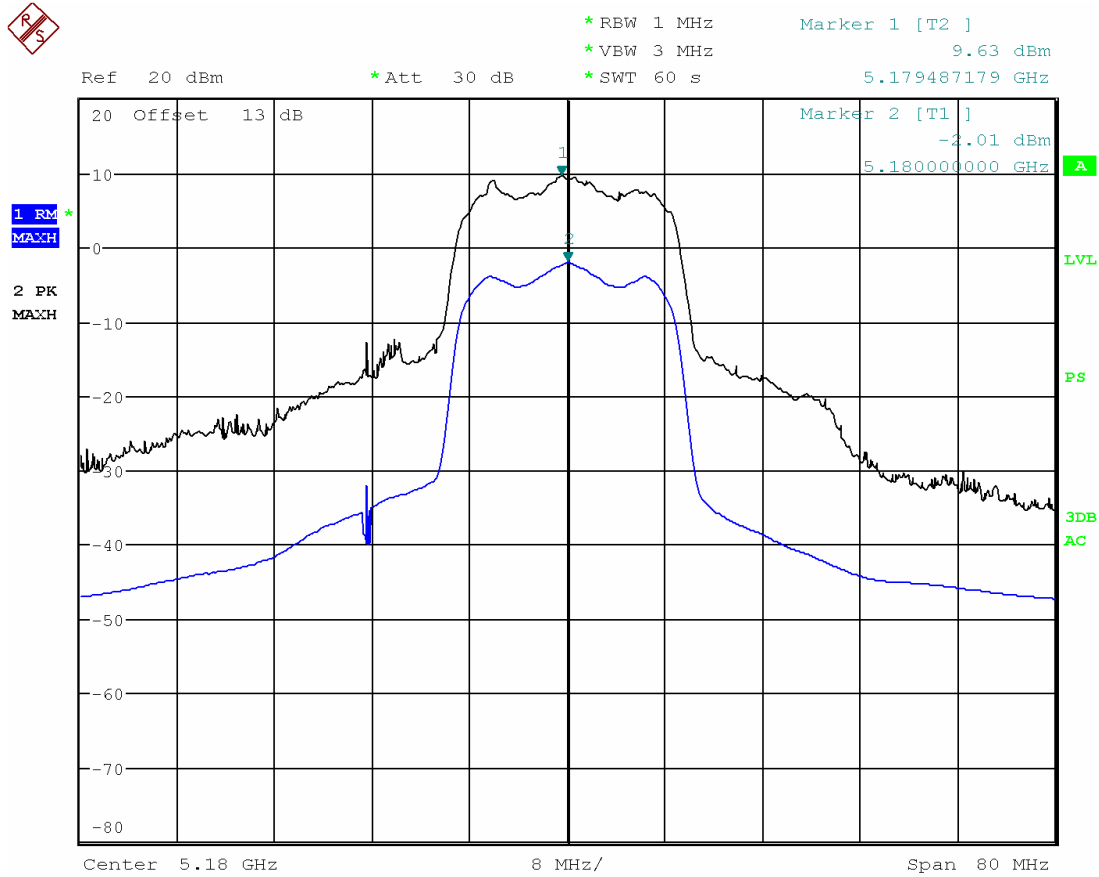

Channel 5200MHz

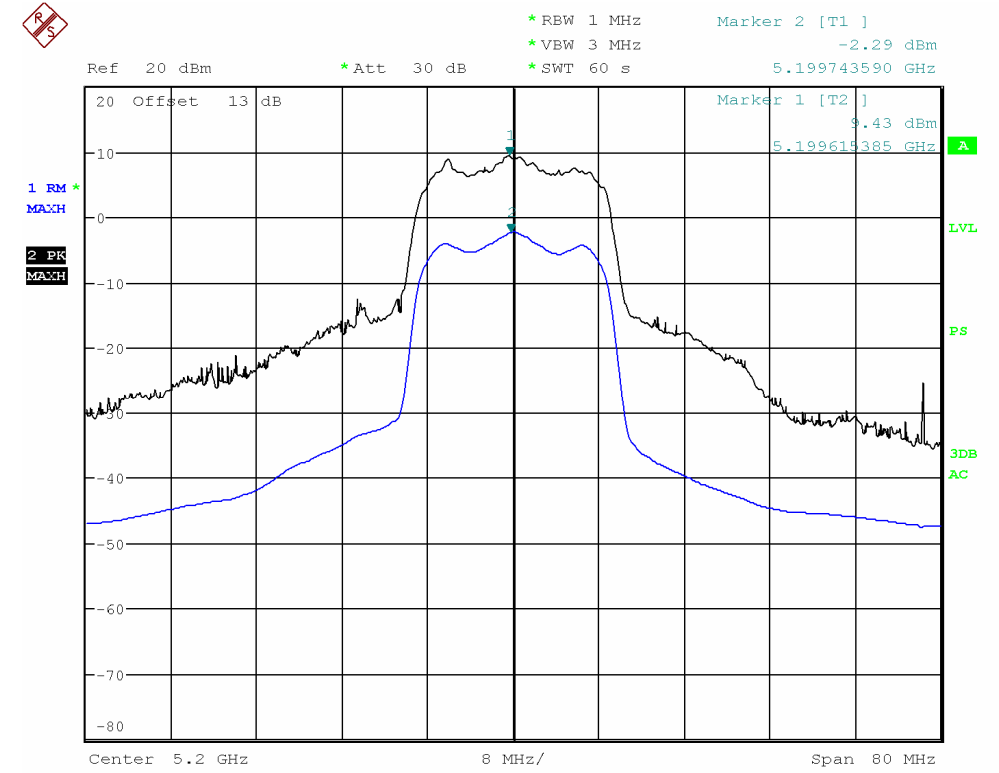

Channel 5240MHz

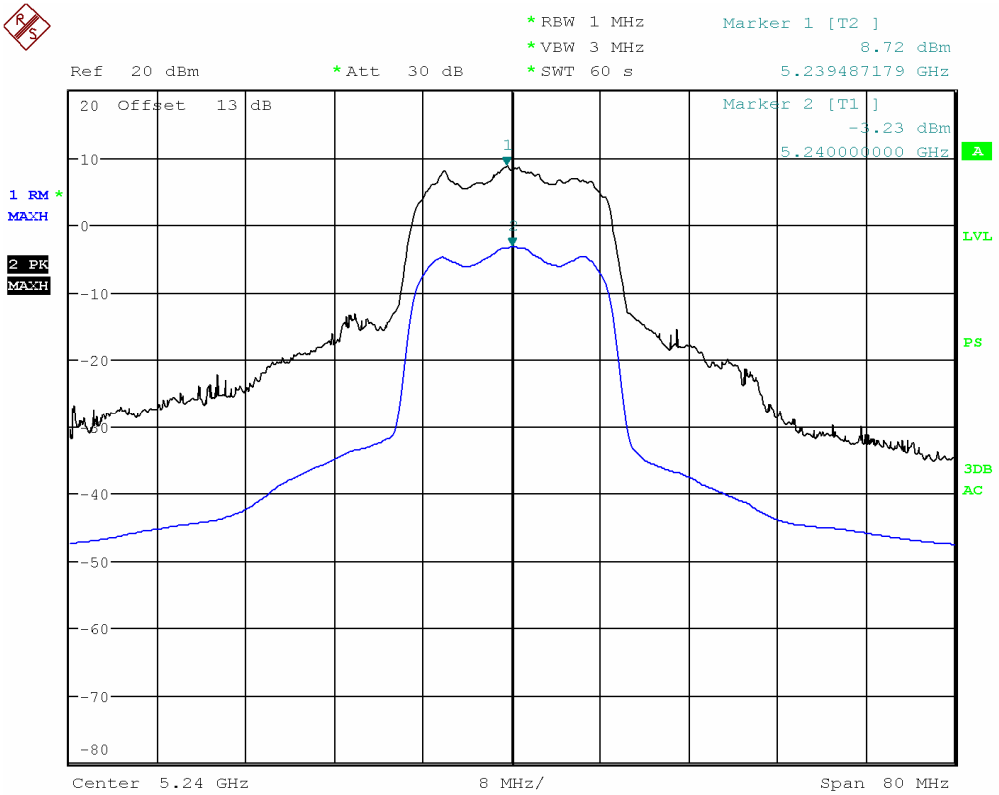

802.11n Mode (HT40):

Channel No.	Frequency (MHz)	Mode	Measured Channel Power (dB)	Limit (dB)	Result
40	5190	802.11n (HT40)	12.2	13	Pass
44	5230		12.7		Pass

802.11n mode (HT40):
Channel 5190MHz

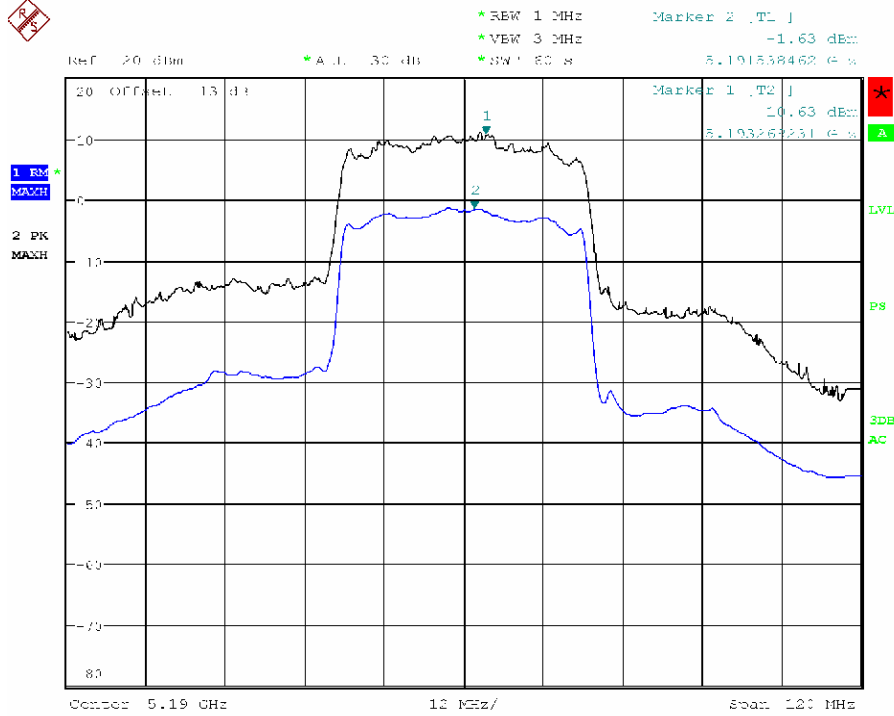

Channel 5230MHz

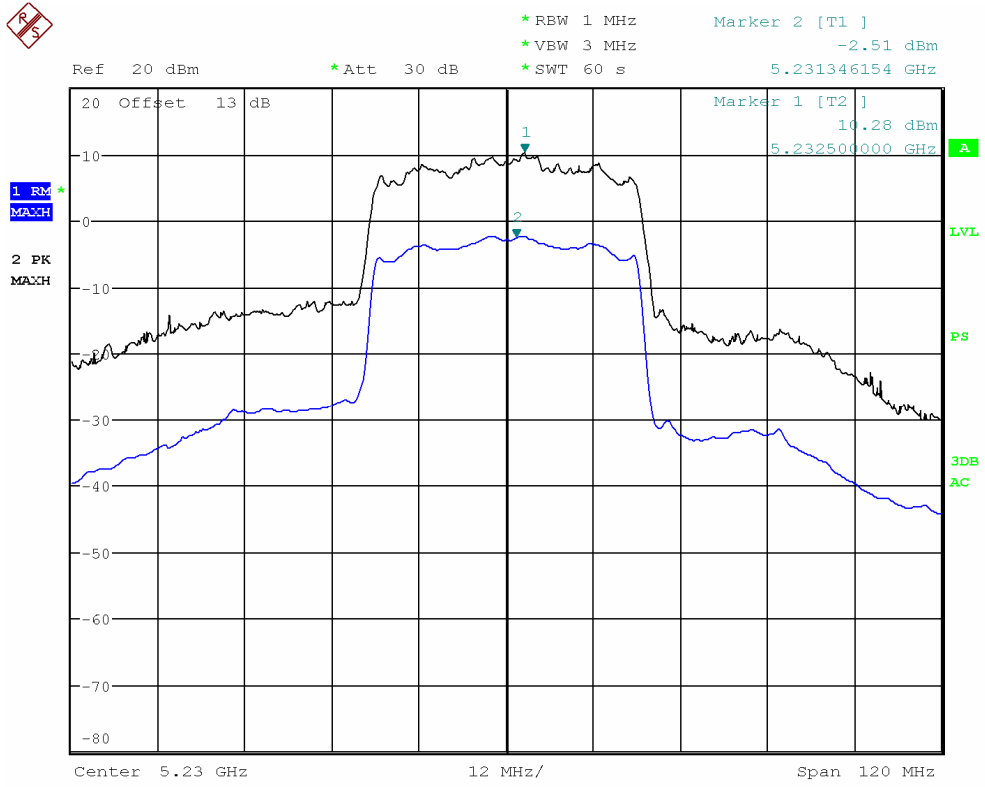

9. FREQUENCY STABILITY

9.1 LIMITS

Manufacturers of U-NII devices are responsible for ensuring frequency stability such that an emission is maintained within the band of operation under all conditions of normal operation as specified in the user manual.

9.2 Method of Measurements

47 CFR §2.1055

9.3 Test Arrangement

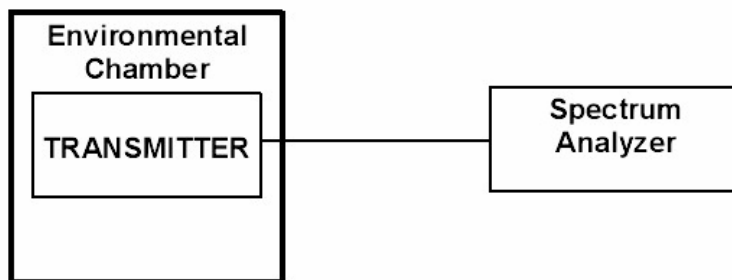

9.4 Test result

Temperature Ratings by Manufacturer:	Operating Temperature 0-50 deg.C
Center Frequency:	
Frequency Tolerance Limit:	Emission must be maintained within the band of operation under all conditions of normal operation as specified. The closest operating channel to the band edge is 20MHz. Therefore, frequency drift shall not exceed 20MHz.
Max. Frequency Tolerance Measured:	+13600 Hz
Input Voltage Rating:	DC 5V

CENTER FREQUENCY & RF POWER OUTPUT VARIATION			
Ambient Temperature (°C)	Supply Voltage (Nominal) DC 5V	Supply Voltage (85% of Nominal) DC 4.25V	Supply Voltage (115% of Nominal) DC 5.75V
	Hz	Hz	Hz
-30	+12560	N/A	N/A
+20	0	-260	+48
+50	+13200	N/A	N/A

10 CONDUCTED SPURIOUS EMISSIONS

10.1 LIMITS

At least 15 channels frequency

10.2 TEST PROCEDURES

Remove the antenna from the EUT and then connect a low attenuation cable from the antenna port to the spectrum.

Below 1GHz Set the spectrum analyzer: RBW =100KHz VBW >= RBW , Span = enough to captch the trace. Sweep = auto; Detector Function = Peak. Trace = Max,hold.

10.3 TEST SETUP

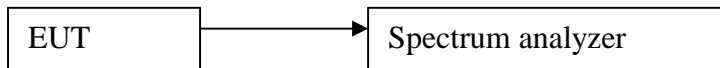

10.4 TEST RESULTS

802.11n mode:
Channel 5180MHz
30MHz~1GHz

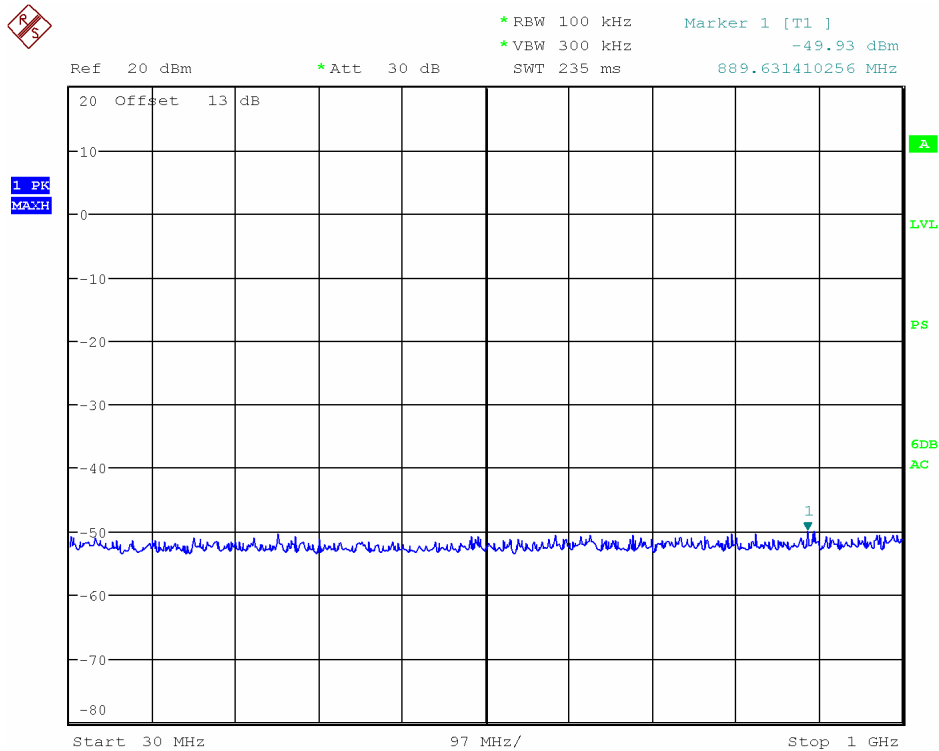

Channel 5180MHz
1GHz~40GHz

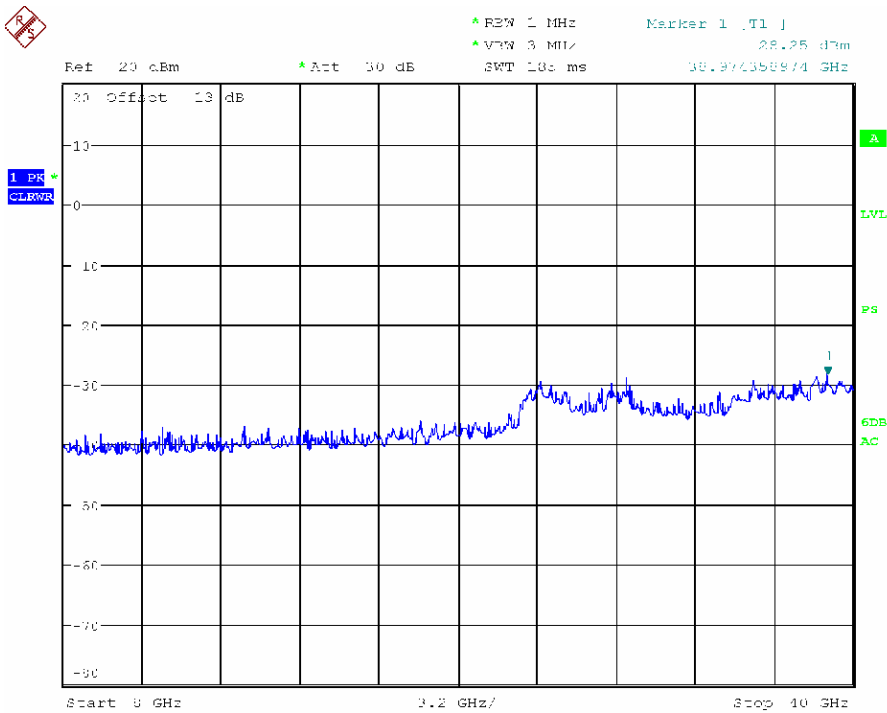
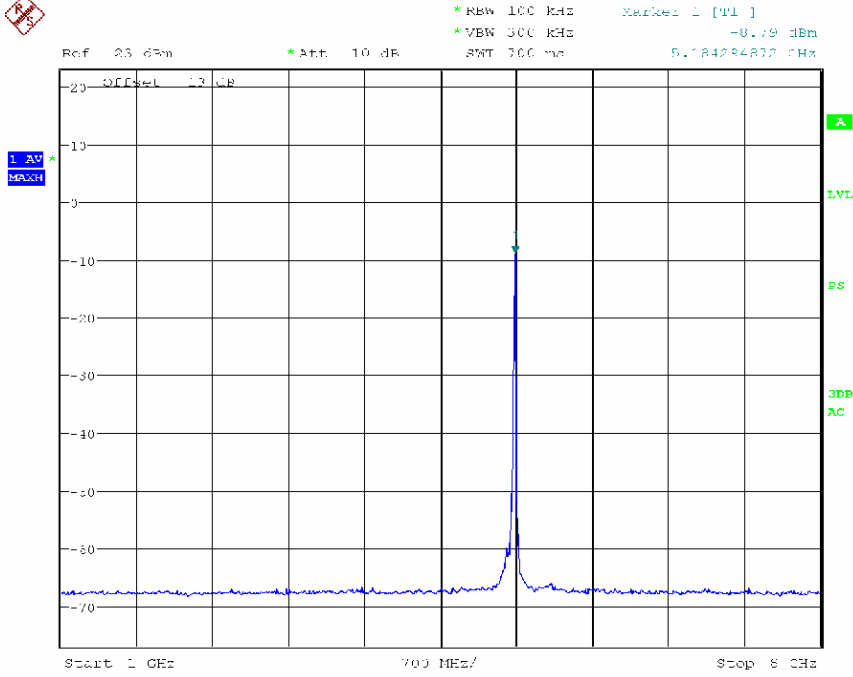

Channel 5200MHz
30MHz~1GHz

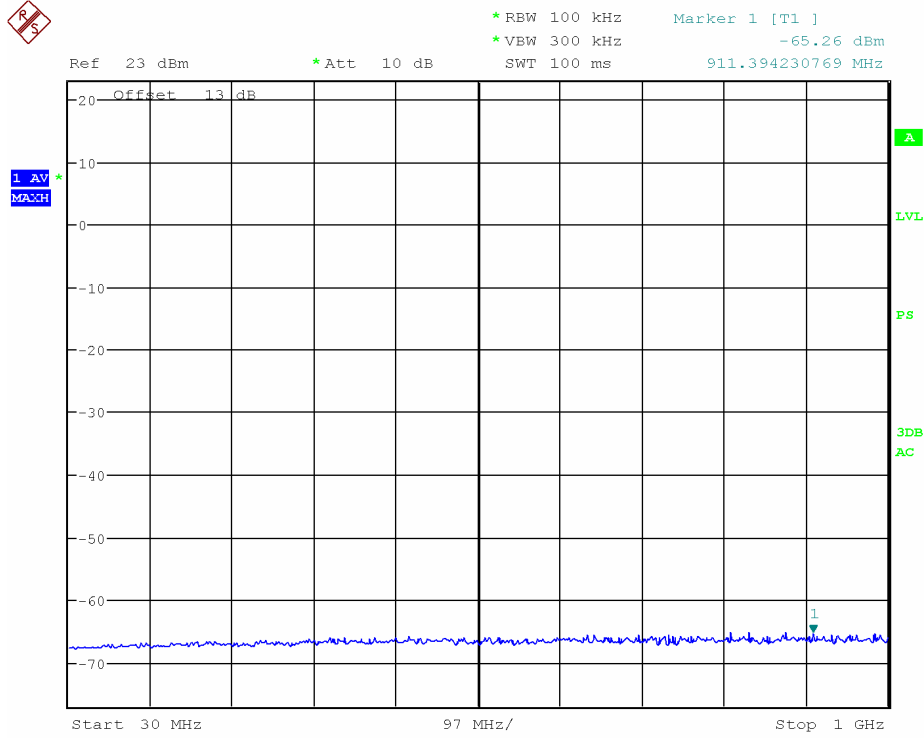

Channel 5200MHz
1GHz~40GHz

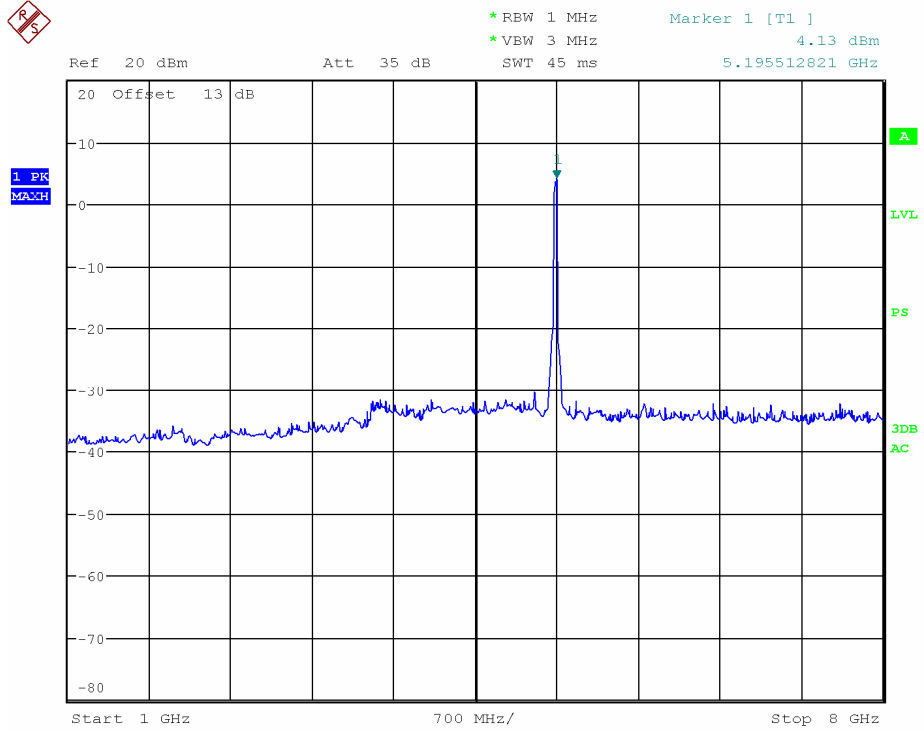

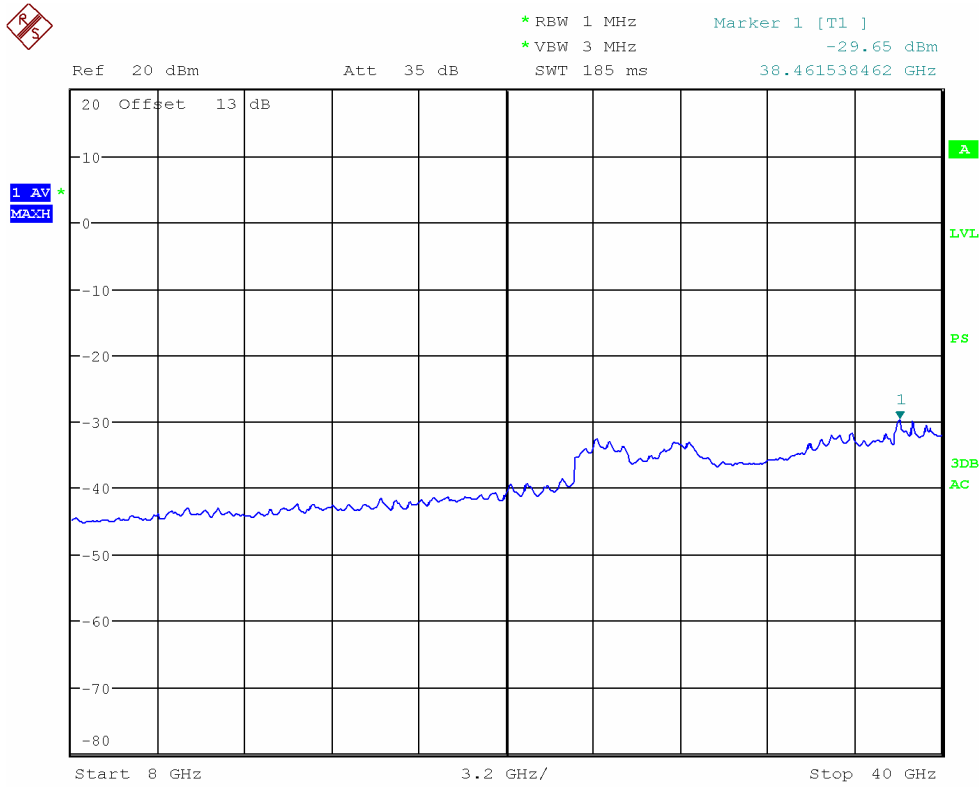

Channel 5240MHz
30MHz~1GHz

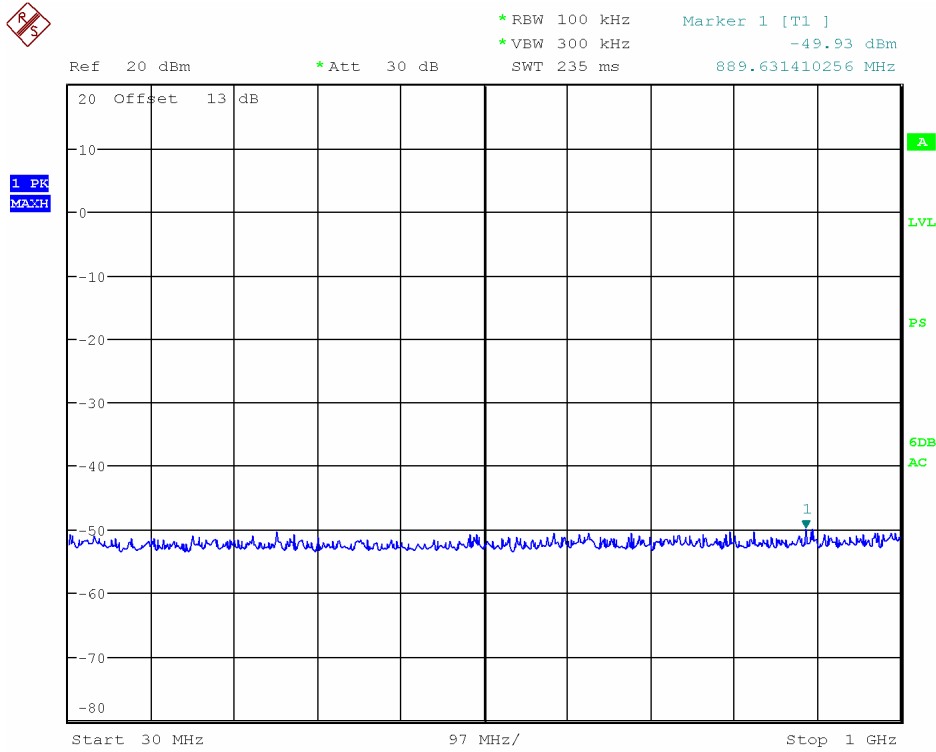

Channel 5240MHz
1GHz~25GHz

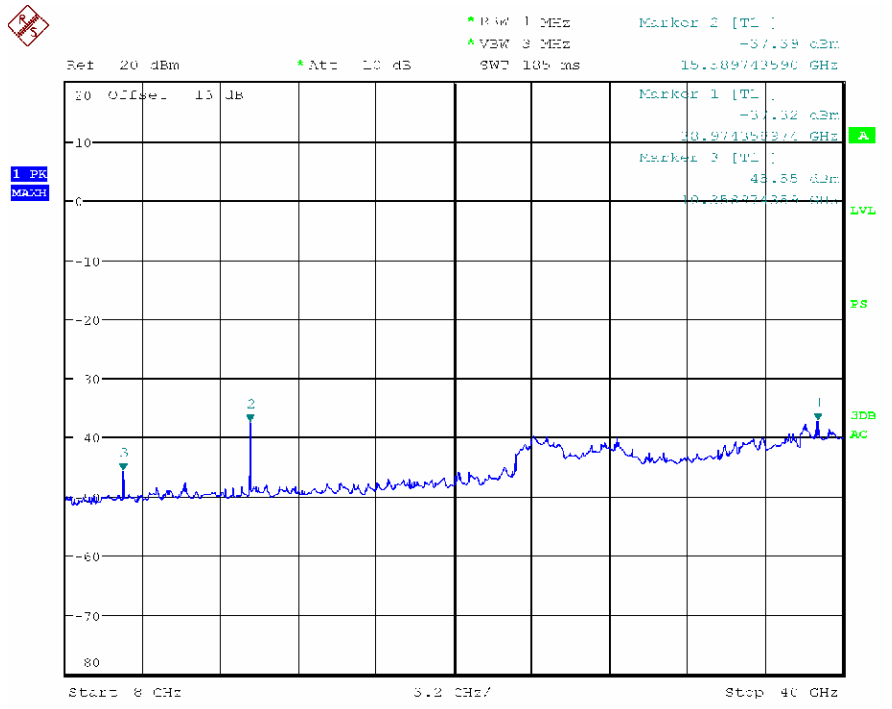
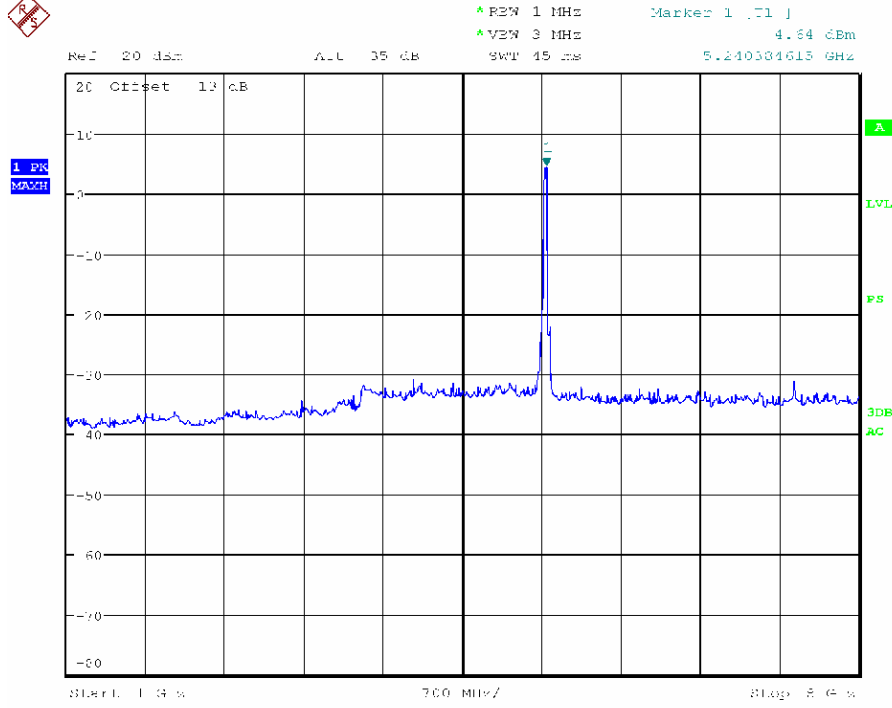

802.11n mode (HT40):
Channel 5190MHz
30MHz~1GHz

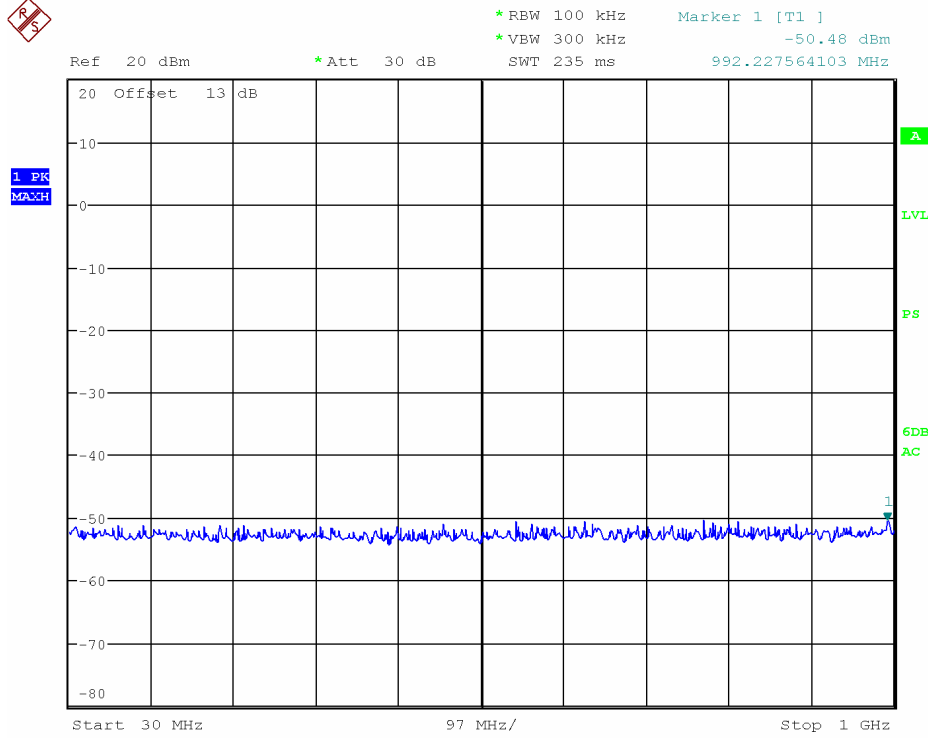

Channel 5190MHz
1GHz~40GHz

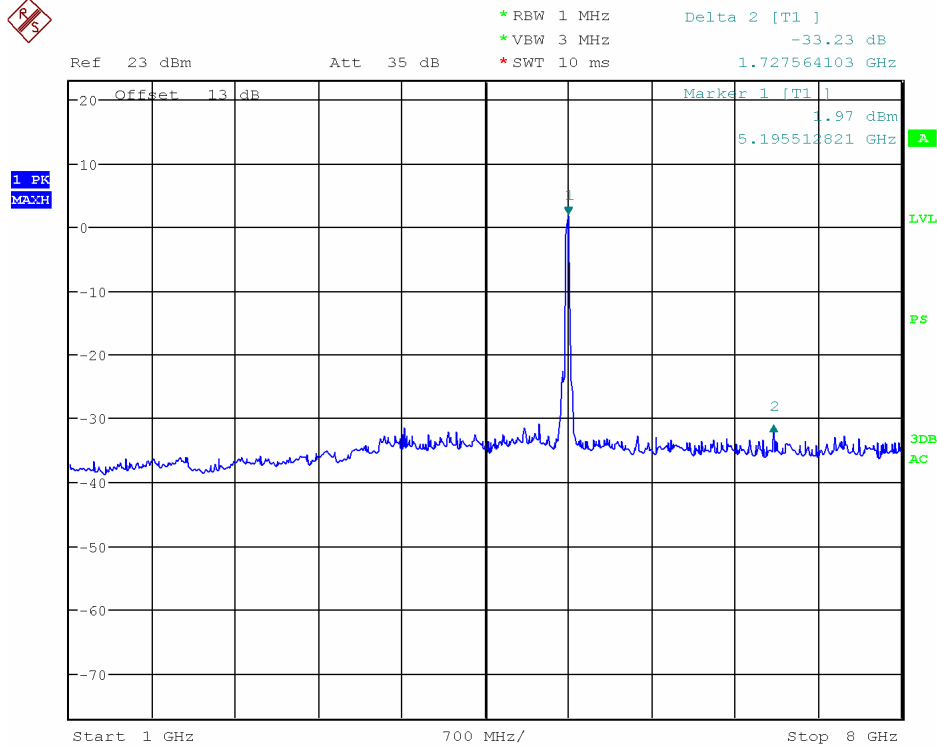

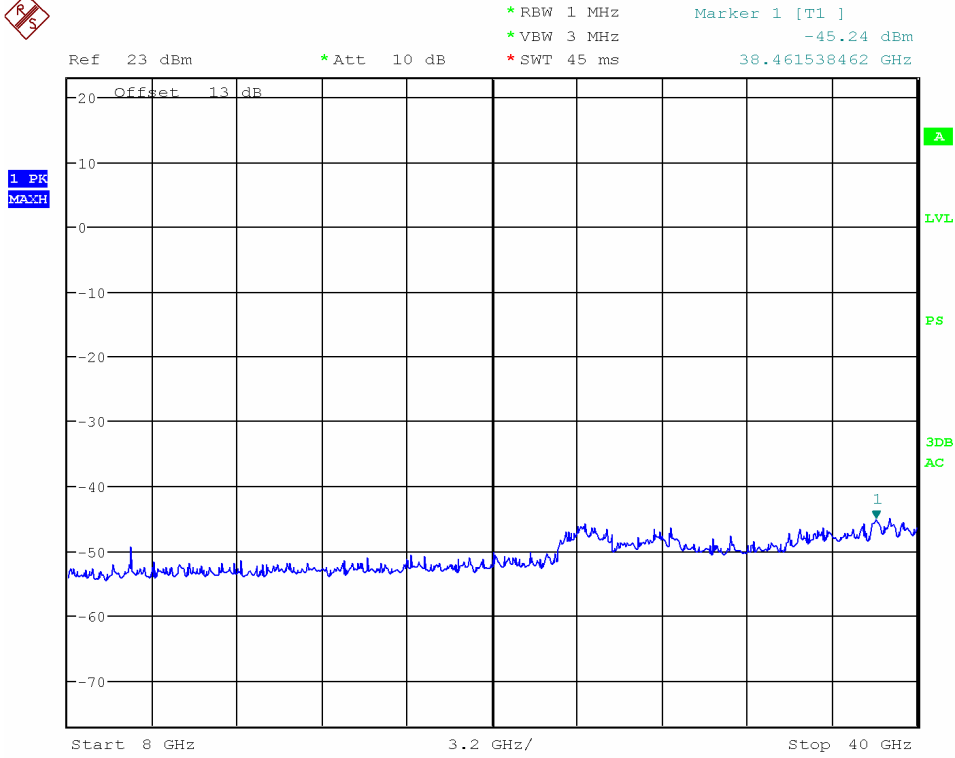

Channel 5230MHz
30MHz~1GHz

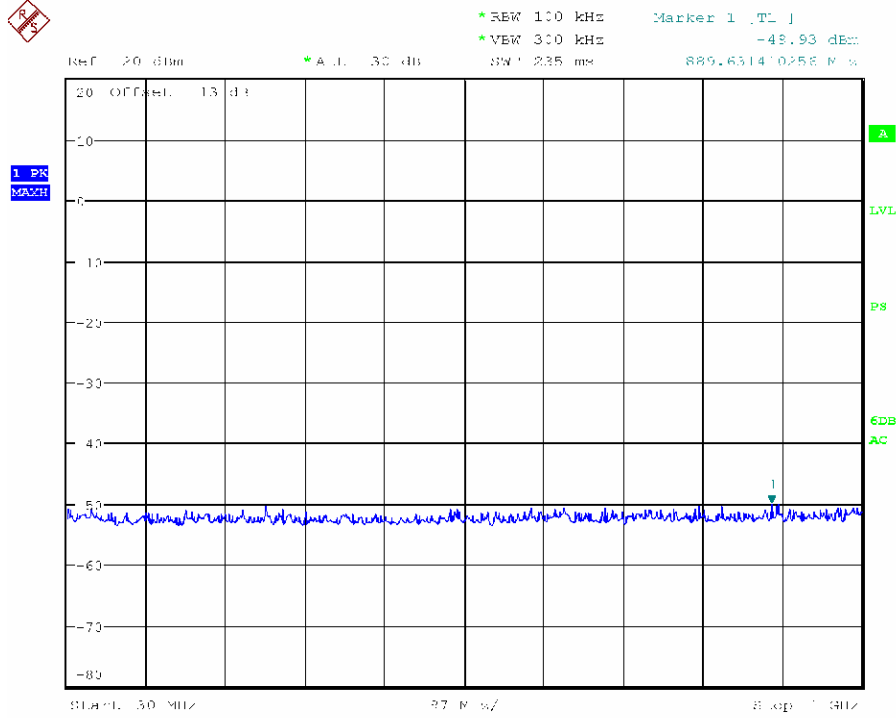

Channel 5230MHz
1GHz~25GHz

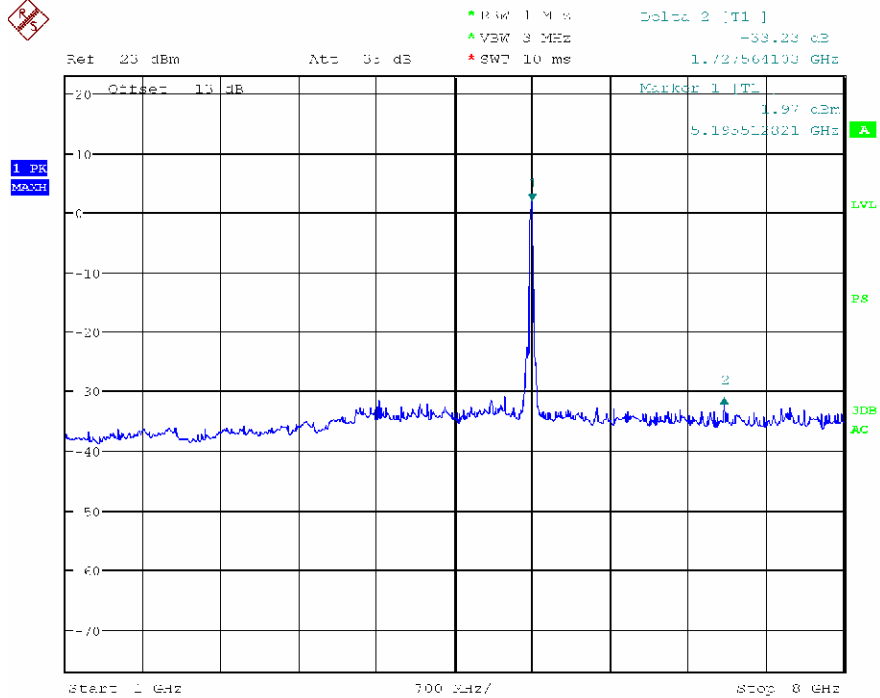

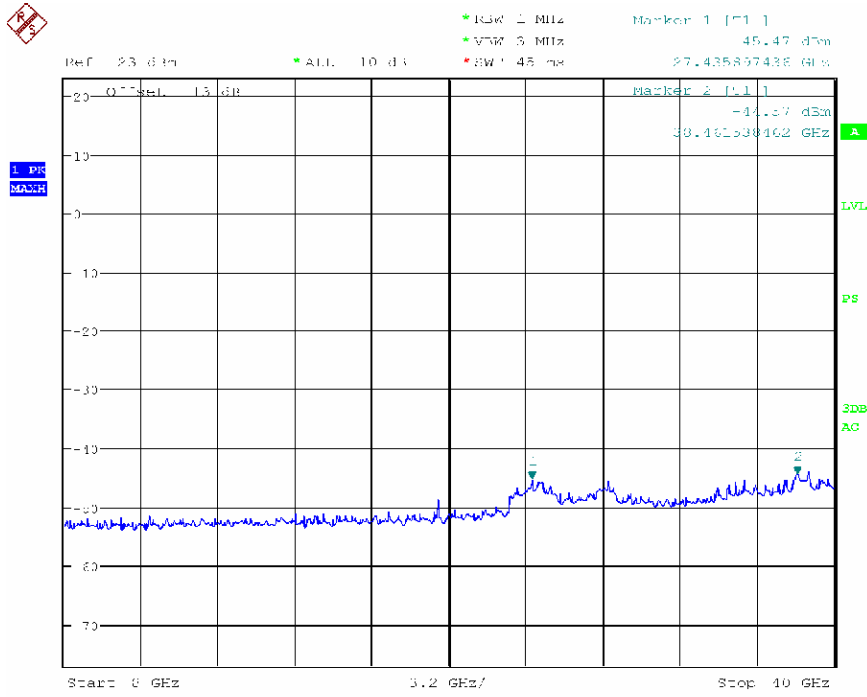

11. RADIATED SPURIOUS EMISSIONS

11.1 LIMITS

Frequency (MHz)	Quasi-peak(dB μ V/m)
30 ~ 88	40
88~216	43.5
216 ~ 960	46
Above 960	54

NOTE: (1) The lower limit shall apply at the transition frequencies.

Frequency (GHz)	Quasi-peak(dB μ V/m)
1 ~ 26.5	74
1~ 26.5	54

11.2 TEST PROCEDURES

Procedure of Preliminary Test

Radiated emission tests shall be made with the receive or transmit antenna located at a horizontal distance of 3 m plus half of the maximum width of the EUT being tested, measured from the centre of the EUT. The tests shall be performed with the equipment configured as closely as possible to its typical, practical operation. Unless stated otherwise, cables and wiring shall be as specified by the manufacturer and the equipment shall be in its housing (or cabinet) with all covers and access panels in place. Any deviation from normal EUT operating conditions shall be included in the test report.

The EUT (on a non-conductive support structure, where applicable) shall be placed on a remotely operated turntable, to allow the EUT to be rotated. The height of the EUT above the ground plane shall be according to the following requirements.

- Table-top equipment is placed on a non-conductive set-up table with height 0,8 m \pm 0,01 m, ANSI C63.4 specifies the method to determine the impact of the non-conductive set-up table on test results.
- Floor-standing equipment is placed on a non-conductive support, as specified in the applicable product standard. If there are no EUT height placement requirements in the product standard, the EUT shall be placed on a non-conductive support at a height of 5 cm to 15 cm above the ground plane.

Interface cables, loads, and devices should be connected to at least one of each type of the interface ports of the EUT and, where practical, each cable shall be terminated in a device typical for its actual use. Where there are multiple interface ports of the same type, a typical number of these devices shall be connected to devices or loads. It is sufficient to connect only one of the loads, provided that it can be shown, for example by preliminary testing, that the connection of further ports would not significantly increase the level of disturbance (that is, more than 2 dB) or significantly degrade the immunity level.

The test mode(s) described in Item 2.4 were scanned during the preliminary test. After the preliminary scan, we found the test mode described in Item 2.4 producing the highest emission level. The EUT and cable configuration, antenna position, polarization and turntable position of the above highest emission level were recorded for the final test.

Procedure of Final Test

EUT and support equipment were set up on the turntable as per the configuration with highest emission level in the preliminary test. The Analyzer / Receiver scanned from 30MHz to 1000MHz. Emissions were scanned and measured rotating the EUT to 360 degrees, varying cable placement and positioning the antenna 1 to 4 meters above the ground plane, in both the vertical and the horizontal polarization, to maximize the emission reading level. Record at least six highest emissions. Emission frequency, amplitude, antenna position, polarization and turntable position were recorded into a computer in which correction factors were used to calculate the emission level and compare reading to the applicable limit and only QP reading is presented. The test data of the worst-case condition(s) was recorded.

Procedure of Final Test

EUT and support equipment were set up on the test bench as per the configuration with highest emission level in the preliminary test. A scan was taken on both power lines, recording at least the six highest emissions. Emission frequency and amplitude were recorded into a computer in which correction factors were used to calculate the emission level and compare reading to the applicable limit. The test data of the worst-case condition(s) was recorded.

11.3 TEST SETUP

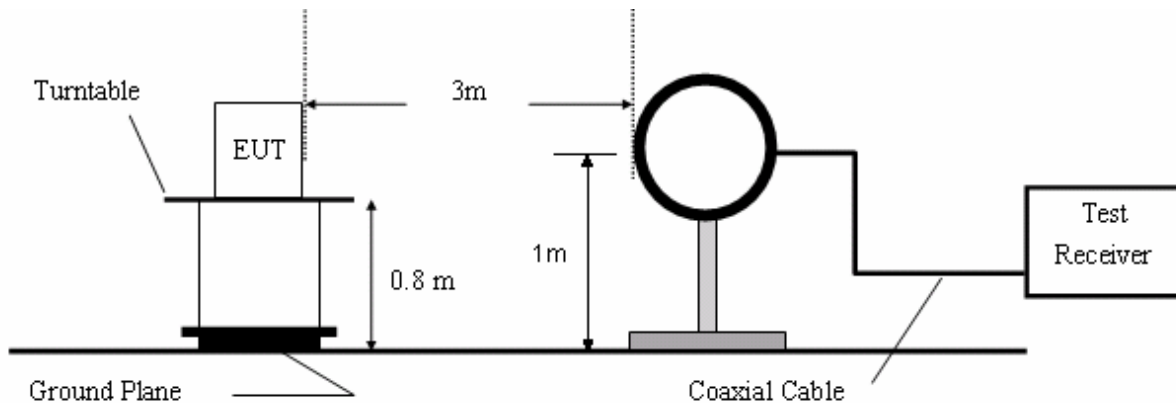

Figure 1. 9KHz to 30MHz radiated emissions test configuration

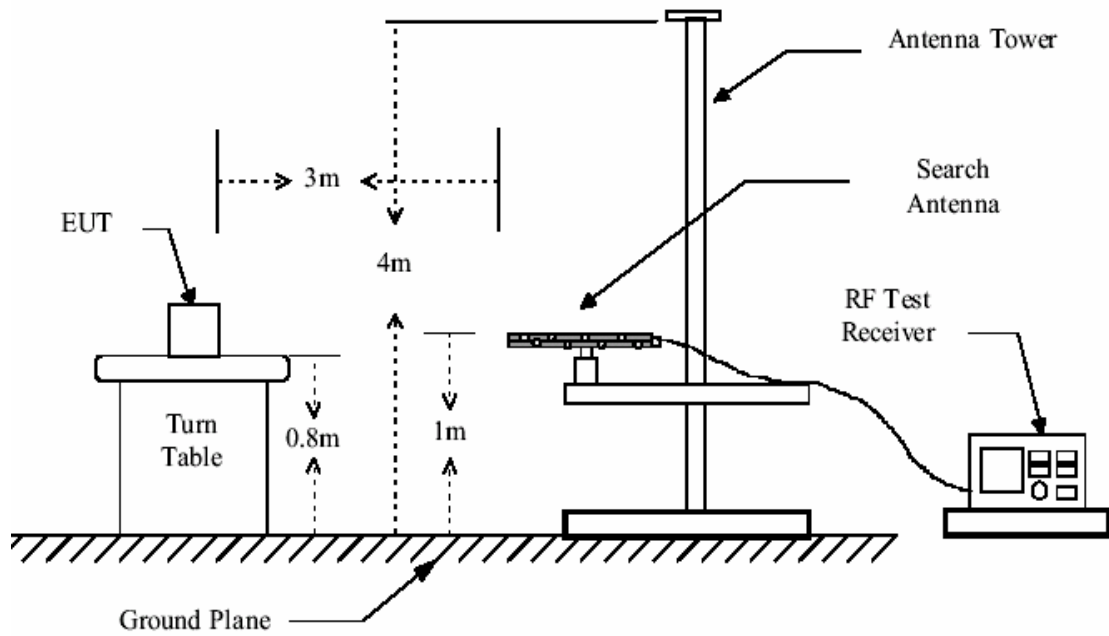

Figure 2. 30MHz to 1GHz radiated emissions test configuration

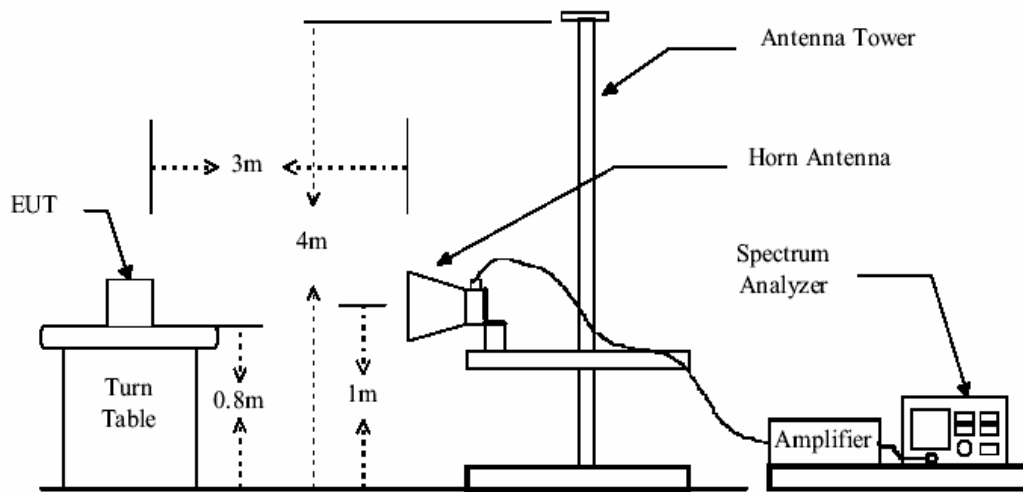

Figure 3. Above 1GHz radiated emissions test configuration

11.4 HARMONIC AND OTHER SPURIOUS EMISSIONS

10.4.1 Test in 802.11n mode lowest channel 5180MHz:

30MHz~1GHz Spurious Emissions .Quasi-Peak Measurement

No.	Frequency (MHz)	Reading (dBuV/m)	Correct Factor(dB/m)	Result (dBuV/m)	Limit (dBuV/m)	Over Limit (dB)	Antenna polarization
1	203.860	21.40	12.80	34.20	43.50	-9.30	Horizontal
2	481.650	21.35	21.25	42.60	46.00	-3.40	H
3	43.4705	21.27	12.73	34.00	40.00	-6.00	Vertical
4	50.5928	21.22	10.38	31.60	40.00	-8.40	V

1~25 GHz Harmonics & Spurious Emissions. Peak & Average Measurement

Peak Measurement:

No.	Frequency (MHz)	Reading (dBuV/m)	Correct Factor(dB/m)	Result (dBuV/m)	Limit (dBuV/m)	Over Limit (dB)	Antenna polarization
1	2590.225	40.35	-2.21	38.14	74.00	-35.86	Horizontal
2	10360.000	55.52	4.42	59.94	74.00	-14.06	H
3	15540.000	39.29	9.83	49.12	74.00	-24.88	H
4	2590.154	42.88	-2.52	40.36	74.00	-33.64	Vertical
5	10360.000	54.65	4.39	59.04	74.00	-14.96	V
6	15540.000	40.02	9.74	49.76	74.00	-24.24	V

Average Measurement:

No.	Frequency (MHz)	Reading (dBuV/m)	Correct Factor(dB/m)	Result (dBuV/m)	Limit (dBuV/m)	Over Limit (dB)	Antenna polarization
1	2590.225	36.05	-2.21	33.84	54.00	-20.16	Horizontal
2	10360.000	48.34	4.42	52.76	54.00	-1.24	H
3	15540.000	33.42	9.83	43.25	54.00	-10.75	H
4	2590.154	37.89	-2.52	35.37	54.00	-18.63	Vertical
5	10360.000	46.81	4.39	51.20	54.00	-2.80	V
6	15540.000	34.68	9.74	44.42	54.00	-9.58	V

The field strength is calculated by adding the Antenna Factor. Correct Factor.

The basic equation with a sample calculation is as follows:

Final Test Level =Receiver Reading + Correct Factor

11.4.2 Test in 802.11n mode middle channel 5200MHz:

30MHz~1GHz Spurious Emissions .Quasi-Peak Measurement

No.	Frequency (MHz)	Reading (dBuV/m)	Correct Factor(dB/m)	Result (dBuV/m)	Limit (dBuV/m)	Over Limit (dB)	Antenna polarization
1	203.880	21.42	12.80	34.22	43.50	-9.28	Horizontal
2	319.577	24.52	16.20	40.72	47.00	-6.09	H
3	44.709	24.78	11.66	36.44	40.00	-1.56	Vertical
4	113.000	23.64	9.31	32.95	40.00	-7.05	V

1~25 GHz Harmonics & Spurious Emissions. Peak & Average Measurement

Peak Measurement:

No.	Frequency (MHz)	Reading (dBuV/m)	Correct Factor(dB/m)	Result (dBuV/m)	Limit (dBuV/m)	Over Limit (dB)	Antenna polarization
1	2600.435	40.42	-2.21	38.21	74.00	-35.79	Horizontal
2	10400.000	55.67	4.46	60.13	74.00	-13.87	H
3	15600.000	39.00	9.80	48.80	74.00	-25.20	H
4	2600.005	42.05	-2.52	39.53	74.00	-34.47	Vertical
5	10400.000	54.65	4.46	59.11	74.00	-14.89	V
6	15600.000	40.02	9.80	49.82	74.00	-24.18	V

Average Measurement:

No.	Frequency (MHz)	Reading (dBuV/m)	Correct Factor(dB/m)	Result (dBuV/m)	Limit (dBuV/m)	Over Limit (dB)	Antenna polarization
1	2600.435	36.11	-2.21	33.90	54.00	-20.10	Horizontal
2	10400.000	48.56	4.46	53.02	54.00	-0.80	H
3	15600.000	34.78	9.80	44.58	54.00	-9.42	H
4	2600.005	36.83	-2.52	34.31	54.00	-19.69	Vertical
5	10400.000	48.22	4.46	52.68	54.00	-1.32	V
6	15600.000	34.65	9.80	44.45	54.00	-9.55	V

The field strength is calculated by adding the Antenna Factor. Correct Factor.

The basic equation with a sample calculation is as follows:

Final Test Level =Receiver Reading + Correct Factor

11.4.3 Test in 802.11n mode highest channel 5240MHz:

30MHz~1GHz Spurious Emissions .Quasi-Peak Measurement

No.	Frequency (MHz)	Reading (dBuV/m)	Correct Factor(dB/m)	Result (dBuV/m)	Limit (dBuV/m)	Over Limit (dB)	Antenna polarization
1	160.100	28.12	10.69	38.81	40.00	-1.19	Horizontal
2	248.172	30.53	13.60	44.13	47.00	-2.87	H
3	45.002	24.60	11.66	36.26	40.00	-3.74	Vertical
4	114.230	23.72	9.31	33.03	40.00	-6.97	V

1~25 GHz Harmonics & Spurious Emissions. Peak & Average Measurement

Peak Measurement:

No.	Frequency (MHz)	Reading (dBuV/m)	Correct Factor(dB/m)	Result (dBuV/m)	Limit (dBuV/m)	Over Limit (dB)	Antenna polarization
1	2615.636	41.11	-3.85	37.26	74.00	-36.74	Horizontal
2	10460.000	54.86	4.43	59.29	74.00	-14.71	H
3	15690.000	39.15	9.81	48.96	74.00	-25.04	H
4	2615.789	42.88	-2.52	40.36	74.00	-33.64	Vertical
5	10460.000	54.65	4.43	59.08	74.00	-14.92	V
6	15690.000	39.02	9.81	48.83	74.00	-25.17	V

Average Measurement:

No.	Frequency (MHz)	Reading (dBuV/m)	Correct Factor(dB/m)	Result (dBuV/m)	Limit (dBuV/m)	Over Limit (dB)	Antenna polarization
1	2615.636	37.43	-3.85	33.58	54.00	-20.42	Horizontal
2	10460.000	47.65	4.43	52.08	54.00	-1.92	H
3	15690.000	33.74	9.81	43.55	54.00	-10.45	H
4	2615.789	37.85	-2.52	35.33	54.00	-18.67	Vertical
5	10460.000	49.48	4.43	53.91	54.00	-0.09	V
6	15690.000	33.09	9.81	42.90	54.00	-11.1	V

The field strength is calculated by adding the Antenna Factor. Correct Factor.

The basic equation with a sample calculation is as follows:

Final Test Level =Receiver Reading + Correct Factor

Remark: No any other emissions level which are attenuated less than 20dB below the limit.

According to 15.31(o), The amplitude of spurious emissions from intentional radiators and emissions from unintentional radiators which are attenuated more than 20 dB below the permissible value need not be reported unless specifically required elsewhere in this Part.

Hence there no other emissions have been reported.

Remark:

- 1). N/A: For this intentional radiator operates below 25 GHz. The spectrum shall be investigated to the tenth harmonic of the highest fundamental frequency. And above the third harmonic of this intentional radiator, the disturbance is very low. So the test result only displays to 3rd harmonic.
- 2). As shown in Section, for frequencies above 1000 MHz. the above field strength limits are based on average limits. However, the peak field strength of any emission shall not exceed the maximum permitted average limits specified above by more than 20 dB under any condition of modulation.
- 3). The test only perform the EUT in transmitting status since the test frequencies were over 1GHz only required transmitting status.

Test result: The unit does meet the requirements.

11.5 RADIATED EMISSIONS WHICH FALL IN THE RESTRICTED BANDS

11.5.1 LIMITS

According to Section 15.247(d), In addition, radiated emissions which fall in the restricted bands, as defined in Section 15.205(a), must also comply with the radiated emission limits specified in Section 15.209(a) (see Section 15.205(c)).

Table 2 Limit:	40.0 dB μ V/m between 30MHz & 88MHz;
	43.5 dB μ V/m between 88MHz & 216MHz;
	46.0 dB μ V/m between 216MHz & 960MHz;
	54.0 dB μ V/m above 960MHz.

Section 15.205 Restricted bands of operation.

(a) Except as shown in paragraph (d) of this section. only spurious emissions are permitted in any of the frequency bands listed below:

MHz	MHz	MHz	GHz
0.090 - 0.110	16.42 - 16.423	399.9 - 410	4.5 - 5.15
¹ 0.495 - 0.505	16.69475 - 16.69525	608 - 614	5.35 - 5.46
2.1735 - 2.1905	16.80425 - 16.80475	960 - 1240	7.25 - 7.75
4.125 - 4.128	25.5 - 25.67	1300 - 1427	8.025 - 8.5
4.17725 - 4.17775	37.5 - 38.25	1435 - 1626.5	9.0 - 9.2
4.20725 - 4.20775	73 - 74.6	1645.5 - 1646.5	9.3 - 9.5
6.215 - 6.218	74.8 - 75.2	1660 - 1710	10.6 - 12.7
6.26775 - 6.26825	108 - 121.94	1718.8 - 1722.2	13.25 - 13.4
6.31175 - 6.31225	123 - 138	2200 - 2300	14.47 - 14.5
8.291 - 8.294	149.9 - 150.05	2310 - 2390	15.35 - 16.2
8.362 - 8.366	156.52475 - 156.52525	2483.5 - 2500	17.7 - 21.4
8.37625 - 8.38675	156.7 - 156.9	2655 - 2900	22.01 - 23.12
8.41425 - 8.41475	162.0125 - 167.17	3260 - 3267	23.6 - 24.0
12.29 - 12.293	167.72 - 173.2	3332 - 3339	31.2 - 31.8
12.51975 - 12.52025	240 - 285	3345.8 - 3358	36.43 - 36.5
12.57675 - 12.57725	322 - 335.4	3600 - 4400	
13.36 - 13.41			

11.5.2 TEST RESULT

1. Lowest Channel

No.	Frequency (MHz)	PK Reading (dBuV/m)	AV Reading (dBuV/m)	Correct Factor(dB/m)	Peak (dBuV/m)	Average (dBuV/m)
1	5150.000	49.63	45.20	2.22	51.85	47.42
2	5350.000	49.25	45.00	1.89	51.14	46.89

2. Highest Channel

No.	Frequency (MHz)	PK Reading (dBuV/m)	AV Reading (dBuV/m)	Correct Factor(dB/m)	Peak (dBuV/m)	Average (dBuV/m)
1	5150.000	48.58	44.06	2.22	50.80	46.28
2	5350.000	48.03	43.95	1.89	49.92	45.84

Remark: No any other emission which falls in restricted bands can be detected and be reported.
The unit does meet the FCC requirements.

12. BAND EDGE

12.1 LIMITS

In any 100 kHz bandwidth outside the frequency band in which the spread spectrum or digitally modulated intentional radiator is operating, the radio frequency power that is produced by the intentional radiator shall be at least 20 dB below that in the 100 kHz bandwidth within the band that contains the highest level of the desired power, based on either an RF conducted or a radiated measurement, provided the transmitter demonstrates compliance with the peak conducted power limits. If the transmitter complies with the conducted power limits based on the use of RMS averaging over a time interval, as permitted under paragraph (b)(3) of this section, the attenuation required under this paragraph shall be 30 dB instead of 20 dB. Attenuation below the general limits specified in §15.209(a) is not required. In addition, radiated emissions which fall in the restricted bands, as defined in §15.205(a), must also comply with the radiated emission limits specified in §15.209(a) (see §15.205(c)).

12.2 TEST PROCEDURES

1. Check the calibration of the measuring instrument using either an internal calibrator or a known signal from an external generator.
2. Position the EUT without connection to measurement instrument. Turn on the EUT and connect its antenna terminal to measurement instrument via a low loss cable. Then set it to any one measured frequency within its operating range, and make sure the instrument is operated in its linear range.
3. Set RBW to 1000 kHz and VBW of spectrum analyzer to 3000 kHz with a convenient frequency span including 1000 kHz bandwidth from band edge.
Note: For Restricted Band
RBW=1000 kHz
VBW=3000 kHz
4. Measure the highest amplitude appearing on spectral display and set it as a reference level. Plot the graph with marking the highest point and edge frequency.
5. Repeat above procedures until all measured frequencies were complete.

12.3 TEST SETUP

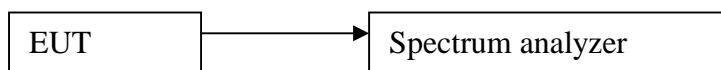

12.4 TEST RESULTS

The band edges were measured and recorded Result:

The Lower Edges attenuated more than 20dB.

The Upper Edges attenuated more than 20dB.

802.11n mode (HT20):
Channel 5180MHz

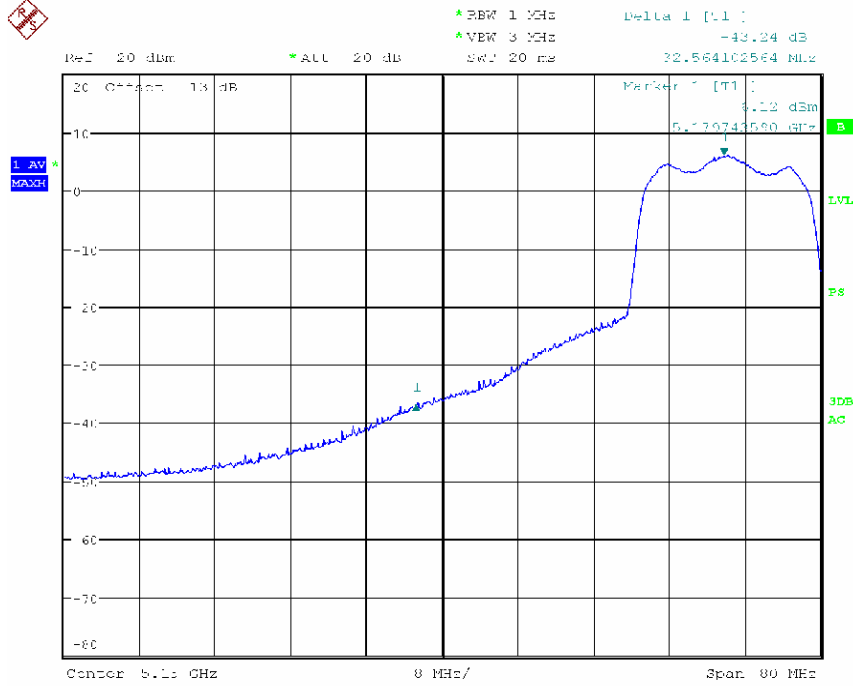

Channel 5240MHz

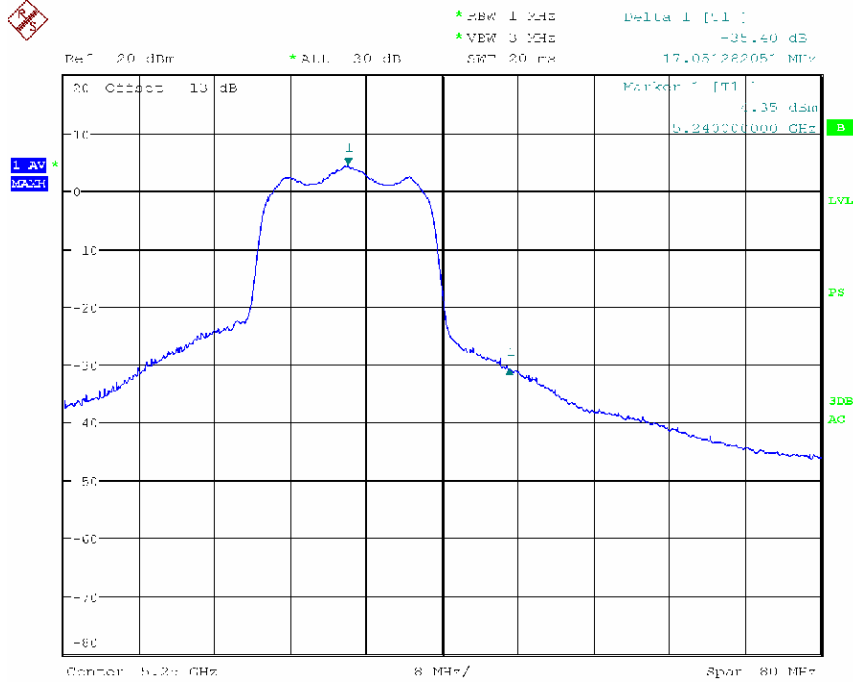

802.11n mode (HT40):

Channel 5190MHz

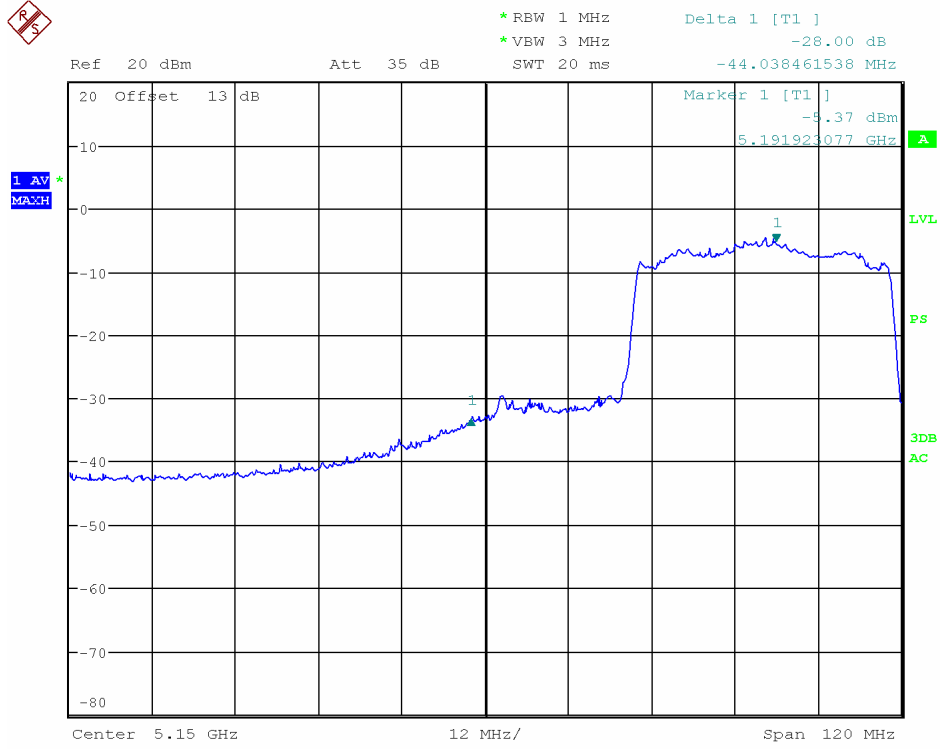

Channel 5230MHz

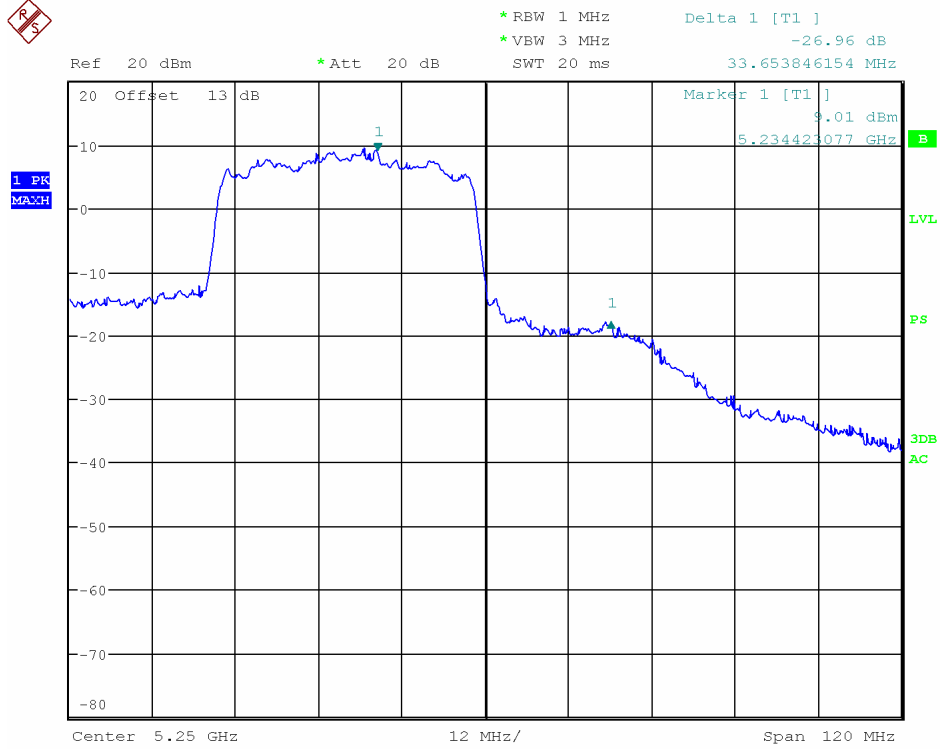

APPENDIX A: PHOTOGRAPH OF THE TEST ARRANGEMENT

RE (Below 1GHz)



RE (30M - 1GHz)

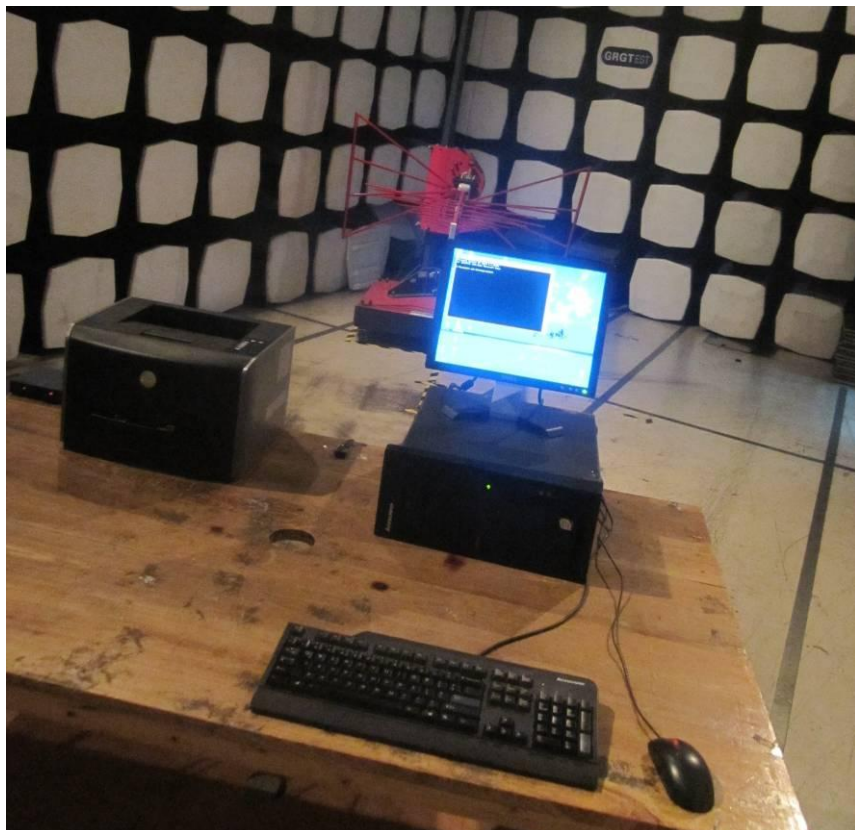

RE (Above 1GHz)

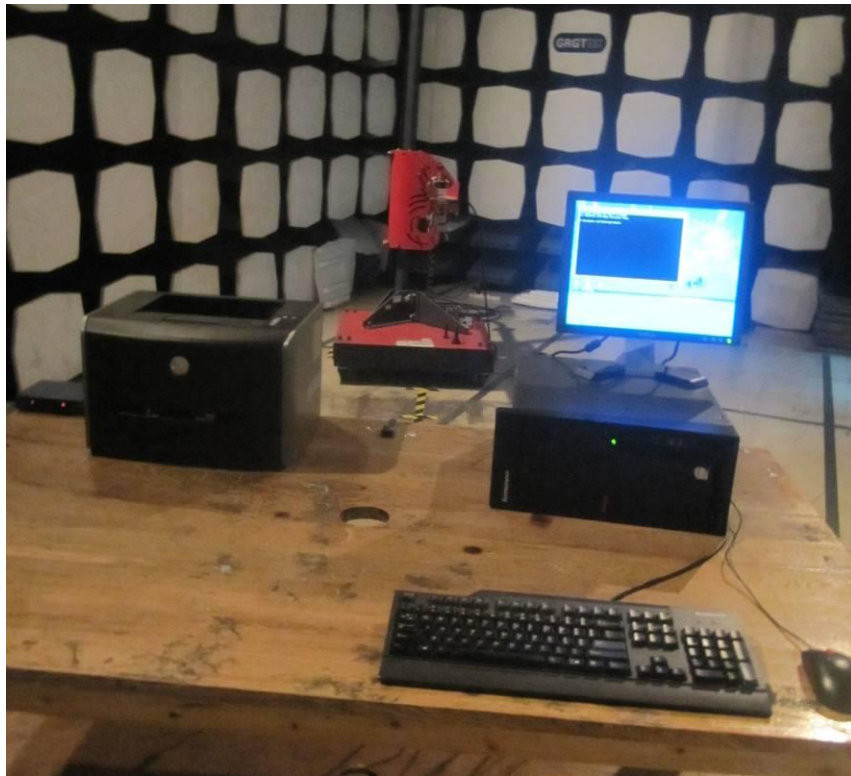

CE



APPENDIX B: PHOTOGRAPH OF THE EUT

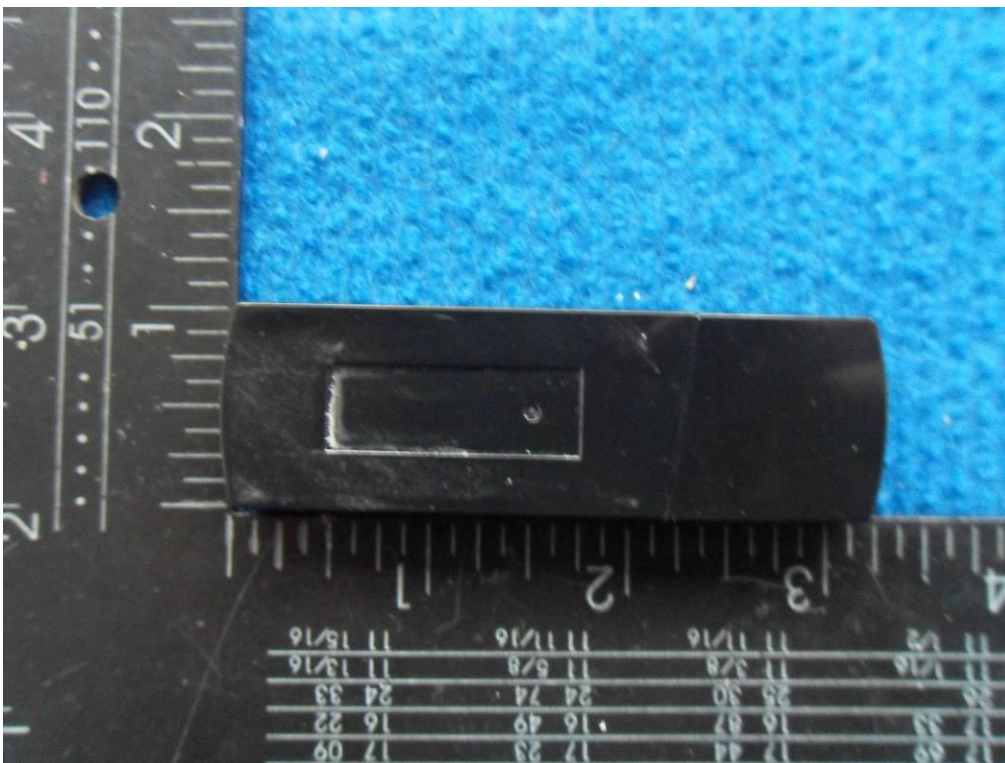

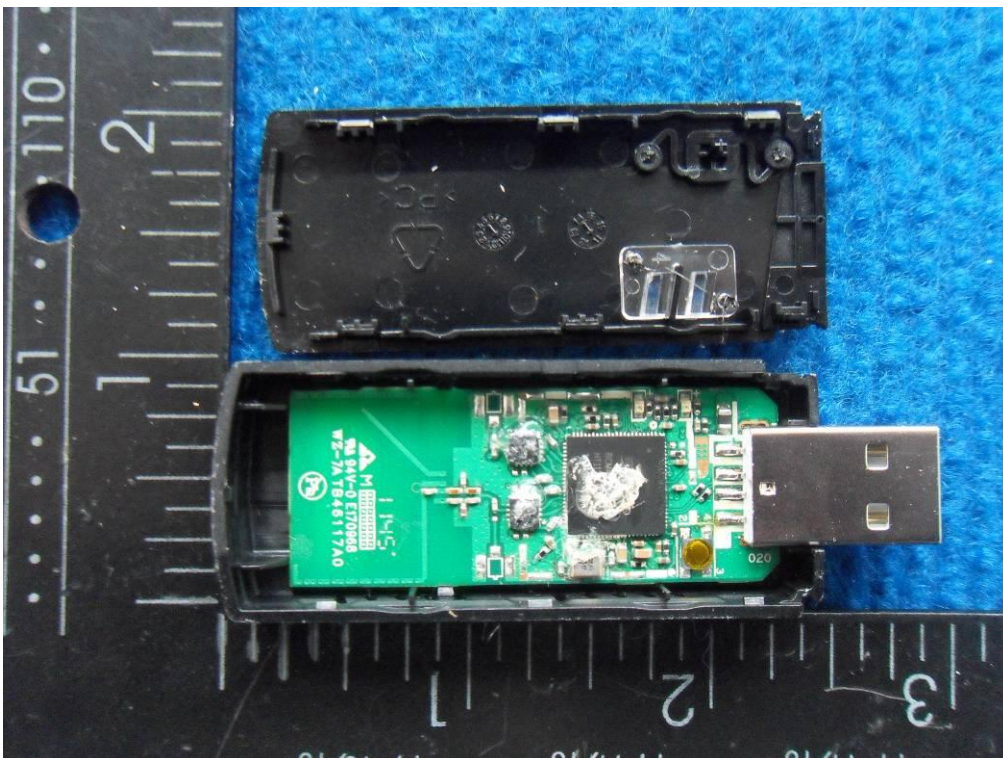
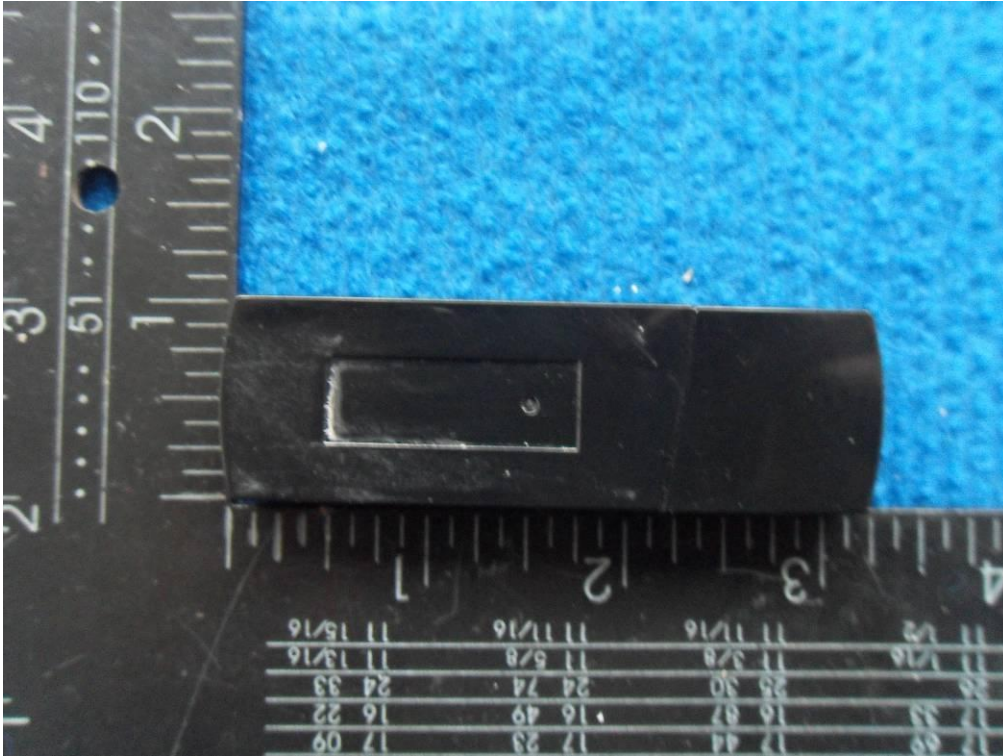

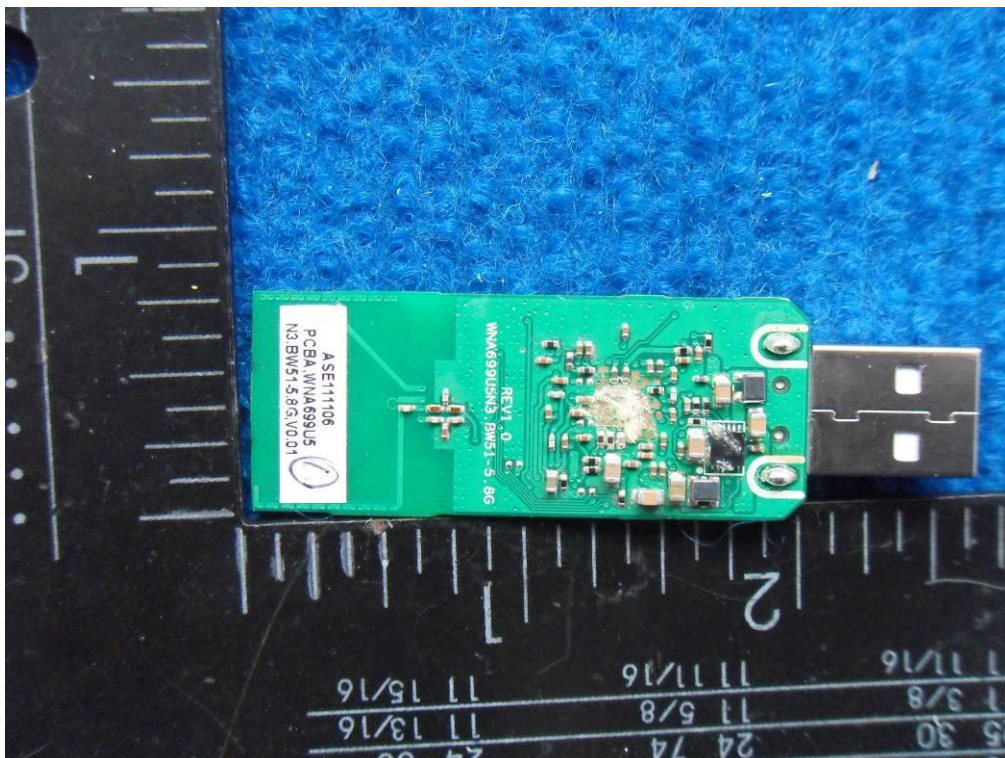
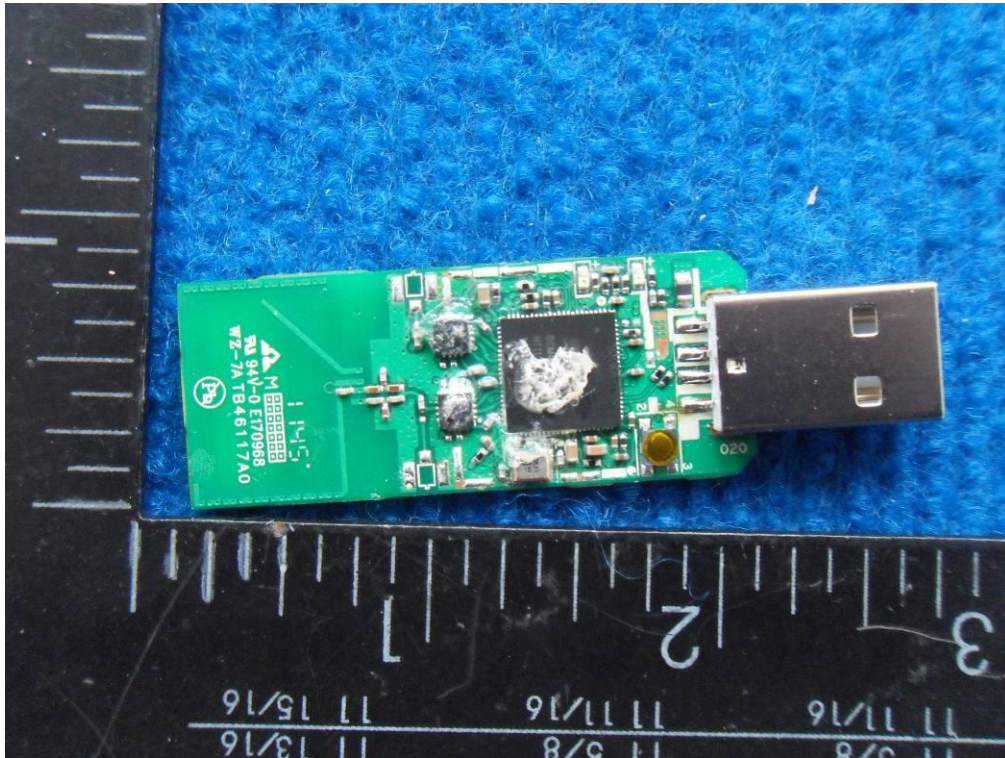

-----This is the last page of the report. -----