



# FCC SAR TEST REPORT

**Report No.:** SET2015-13711  
**Product:** GSM feature Phone  
**Brand Name:** Punkt.  
**Model No.:** MP 01  
**FCC ID:** Z3PMP01  
**Applicant:** Punkt Tronics AG  
**Address:** Via Losanna 4 CH-6900 Lugano, Switzerland  
**Issued by:** CCIC-SET  
**Lab Location:** Electronic Testing Building, Shahe Road, Xili, Nanshan District, Shenzhen, 518055, P. R. China  
**Tel:** 86 755 26627338      **Fax:** 86 755 26627238  
**Mail:** manager@ccic-set.com      **Website:** <http://www.ccic-set.com>

This test report consists of 80 pages in total. It may be duplicated completely for legal use with the approval of the applicant. It should not be reproduced except in full, without the written approval of our laboratory. The client should not use it to claim product endorsement by CCIC-SET. The test results in the report only apply to the tested sample. The test report shall be invalid without all the signatures of testing engineers, reviewer and approver. Any objections must be raised to CCIC-SET within 15 days since the date when the report is received. It will not be taken into consideration beyond this limit.



# Test Report

**Product** .....: GSM feature Phone  
**Model No.** .....: MP 01  
**Brand Name**.....: Punkt.  
**FCC ID**.....: Z3PMP01  
**Applicant**.....: Punkt Tronics AG  
**Applicant Address**.....: Via Losanna 4 CH-6900 Lugano, Switzerland  
**Manufacturer**.....: Amer-Care Co.,limited  
**Manufacturer Address**: Room 2403, West Tower, Nanshan Digital Technology & Cultural Industry Park, Shennan Road No. 10128, Nanshan District, Shenzhen, Guangdong, China

**Test Standards**.....: **47CFR § 2.1093-** Radiofrequency Radiation Exposure Evaluation: Portable Devices;  
**ANSI C95.1–1992:** Safety Levels with Respect to Human Exposure to Radio Frequency Electromagnetic Fields, 3 kHz – 300 GHz.( IEEE Std C95.1-1991)  
**IEEE 1528–2013:** IEEE Recommended Practice for Determining the Peak Spatial-Average Specific Absorption Rate (SAR) in the Human Body Due to Wireless Communications Devices: Experimental Techniques;

**Test Result**.....: Pass

**Tested by** .....: *Mei Chun* 2015-09-25  
 \_\_\_\_\_  
 Chun Mei, Test Engineer

**Reviewed by**.....: *Shuangwen Zhang* 2015-09-25  
 \_\_\_\_\_  
 Shuangwen Zhang, Senior Engineer

**Approved by**.....: *Wu Lian* 2015-09-25  
 \_\_\_\_\_  
 Wu Li'an , Manager



# Contents

- 1. **GENERAL CONDITIONS**-----4
- 2. **ADMINISTRATIVE DATA**-----5
  - 2.1. Identification of the Responsible Testing Laboratory-----5
  - 2.2. Identification of the Responsible Testing Location(s)-----5
  - 2.3. Organization Item-----5
  - 2.4. Identification of Applicant-----5
  - 2.5. Identification of Manufacture-----5
- 3. **EQUIPMENT UNDER TEST (EUT)**-----6
- 4. **SAR SUMMAY**-----7
- 5. **Specific Absorption Rate(SAR)**-----7
  - 5.1. Introduction-----7
  - 5.2. SAR Definition-----8
  - 5.3. Phantoms-----8
  - 5.4. Device Holder-----8
  - 5.5. Probe Specification-----9
- 6. **OPERATIONAL CONDITIONS DURING TEST**-----10
  - 6.1. Schematic Test Configuration-----10
  - 6.2. SAR Measurement System-----10
  - 6.3. Equipments and results of validation testing-----11
  - 6.4. SAR measurement procedure-----13
  - 6.5. Antennas position and test position-----14
- 7. **CHARACTERISTICS OF THE TEST**-----15
  - 7.1. Applicable Limit Regulations-----15
  - 7.2. Applicable Measurement Standards-----15
- 8. **LABORATORY ENVIRONMENT**-----15
- 9. **CONDUCTED RF OUTPUT POWER**-----16
- 10. **TEST RESULTS**-----19
- 11. **MEASUREMENT UNCERTAINTY**-----21
- 12. **MAIN TEST INSTRUMENTS**-----24

**This Test Report consists of the following Annexes:**

<b>Annex A: Test Layout</b> -----	25
<b>Annex B: Sample Photographs</b> -----	30
<b>Annex C: System Performance Check Data and Highest SAR Plots</b> -----	35
<b>Annex D: Calibration Certificate of Probe and Dipoles</b> -----	42



## **1. GENERAL CONDITIONS**

**1.1 This report only refers to the item that has undergone the test.**

**1.2 This report standalone does not constitute or imply by its own an approval of the product by the certification Bodies or competent Authorities.**

**1.3 This document is only valid if complete; no partial reproduction can be made without written approval of CCIC-SET**

**1.4 This report cannot be used partially or in full for publicity and/or promotional purposes without previous written approval of CCIC-SET and the Accreditation Bodies, if it applies.**



## 2. Administrative Date

### 2.1. Identification of the Responsible Testing Laboratory

**Company Name:** CCIC-SET

**Department:** EMC & RF Department

**Address:** Electronic Testing Building, Shahe Road, Nanshan District,  
ShenZhen, P. R. China

**Telephone:** +86-755-26629676

**Fax:** +86-755-26627238

**Responsible Test Lab  
Managers:** Mr. Wu Li'an

### 2.2. Identification of the Responsible Testing Location(s)

**Company Name:** CCIC-SET

**Address:** Electronic Testing Building, Shahe Road, Nanshan District,  
Shenzhen, P. R. China

### 2.3. Organization Item

**CCIC-SET Report No.:** SET2015-13711

**CCIC-SET Project Leader:** Mr. Li Sixiong

**CCIC-SET Responsible  
for accreditation scope:** Mr. Wu Li'an

**Start of Testing:** 2015-09-14

**End of Testing:** 2015-09-16

### 2.4. Identification of Applicant

**Company Name:** Punkt Tronics AG

**Address:** Via Losanna 4 CH-6900 Lugano, Switzerland

### 2.5. Identification of Manufacture

**Company Name:** Amer-Care Co.,limited

**Address:** Room 2403, West Tower, Nanshan Digital Technology &  
Cultural Industry Park, Shennan Road No. 10128, Nanshan  
District, Shenzhen, Guangdong, China

**Notes:** This data is based on the information by the applicant.

### 3. Equipment Under Test (EUT)

#### 3.1. Identification of the Equipment under Test

**Sample Name:** GSM feature Phone

**Type Name:** Punkt.

**Brand Name:** Punkt.

**Model No.:** MP 01

	Support Band	GSM850MHz/1900MHz/900MHz/1800MHz,BT
	Test Band	GSM 850MHz/ GSM 1900MHz
	Development Stage	Identical Prototype
<b>General</b>	Accessories	Power Supply
<b>description:</b>	Battery type	3.7V 1000mAh
	Antenna type	Inner Antenna
	Operation mode	GSM
	Modulation mode	GSM(GMSK)
	Max. RF Power	31.65dBm
	Max. SAR Value	Head: 0.603 W/kg; Body: 0.294 W/kg

#### NOTE:

- The above EUT's information was declared by manufacturer. Please refer to the specifications or user's manual for more detailed description.

## 4 SAR SUMMARY

### Highest Standalone SAR Summary

Exposure Position	Frequency Band	Scaled 1g-SAR(W/kg)	Highest Scaled 1g-SAR(W/kg)
Head	GSM850	0.603	0.603
	GSM1900	0.280	
Body-worn Accessory (15mm Gap)	GSM850	0.292	0.294
	GSM1900	0.294	

## 5 Specific Absorption Rate (SAR)

### 5.1 Introduction

SAR is related to the rate at which energy is absorbed per unit mass in an object exposed to a radio field. The SAR distribution in a biological body is complicated and is usually carried out by experimental techniques or numerical modeling. The standard recommends limits for two tiers of groups, occupational/controlled and general population/uncontrolled, based on a person's awareness and ability to exercise control over his or her exposure. In general, occupational/controlled exposure limits are higher than the limits for general population/uncontrolled.

### 5.2 SAR Definition

The SAR definition is the time derivative (rate) of the incremental energy (dW) absorbed by (dissipated in) an incremental mass (dm) contained in a volume element (dv) of a given density ( $\rho$ ). The equation description is as below:

$$\text{SAR} = \frac{d}{dt} \left( \frac{dW}{dm} \right) = \frac{d}{dt} \left( \frac{dW}{\rho dv} \right)$$

SAR is expressed in units of Watts per kilogram (W/kg)

SAR measurement can be either related to the temperature elevation in tissue by

$$\text{SAR} = C \frac{\delta T}{\delta t}$$

where C is the specific heat capacity,  $\delta T$  is the temperature rise and  $\delta t$  the exposure duration, or related to the electrical field in the tissue by

$$\text{SAR} = \frac{\sigma |E|^2}{\rho}$$

where  $\sigma$  is the conductivity of the tissue,  $\rho$  is the mass density of the tissue and E is the rms electrical field strength.

However for evaluating SAR of low power transmitter, electrical field measurement is typically applied.

### 5.3 Phantoms

The phantom used for all tests i.e. for both system checks and device testing, was the twin-headed "SAM Phantom", manufactured by SATIMO. The SAM twin phantom is a fiberglass shell phantom with 2mm shell thickness (except the ear region, where shell thickness increases to 6mm).

System checking was performed using the flat section, whilst Head SAR tests used the left and right head profile sections. Body SAR testing also used the flat section between the head profiles.



SAM Twin Phantom

### 5.4 Device Holder

The device was placed in the device holder (illustrated below) that is supplied by SATIMO as an integral part of the COMOSAR test system.

The device holder is designed to cope with the different positions given in the standard. It has two scales for device rotation (with respect to the body axis) and device inclination (with respect to the line between the ear reference points). The rotation centers for both scales is the ear reference point (ERP). Thus the device needs no repositioning when changing the angles.

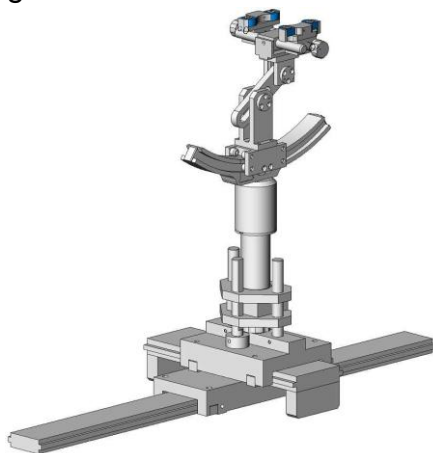

Device holder



### 5.5 Probe Specification



Construction	Symmetrical design with triangular core Interleaved sensors Built-in shielding against static charges PEEK enclosure material (resistant to organic solvents, e.g., DGBE)
Calibration	ISO/IEC 17025 calibration service available.
Frequency	700 MHz to 3 GHz; Linearity: $\pm 0.5$ dB (700 MHz to 3 GHz)
Directivity	$\pm 0.25$ dB in HSL (rotation around probe axis) $\pm 0.5$ dB in tissue material (rotation normal to probe axis)
Dynamic Range	1.5 $\mu$ W/g to 100 mW/g; Linearity: $\pm 0.5$ dB
Dimensions	Overall length: 330 mm (Tip: 20 mm) Tip diameter: 5 mm Distance from probe tip to dipole centers: <2.7 mm
Application	General dosimetry up to 3 GHz Dosimetry in strong gradient fields Compliance tests of mobile phones
Compatibility	COMOSAR

#### Isotropic E-Field Probe

The isotropic E-Field probe has been fully calibrated and assessed for isotropicity, and boundary effect within a controlled environment. Depending on the frequency for which the probe is calibrated the method utilized for calibration will change.

The E-Field probe utilizes a triangular sensor arrangement as detailed in the diagram below:

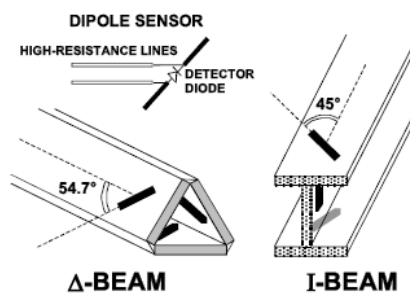

## 6 OPERATIONAL CONDITIONS DURING TEST

### 6.1 Schematic Test Configuration

During SAR test, EUT was operating in Traffic Mode (Channel Allocated) at Normal Voltage Condition. A communication link is set up with a System Simulator (SS) by air link, and a call is established.

The Absolute Radio Frequency Channel Number (ARFCN) was allocated to 128, 189 and 251 respectively in the case of GSM 850MHz, or to 512, 661 and 810 respectively in the case of PCS 1900MHz. The EUT was commanded to operate at maximum transmitting power.

The EUT should use its internal transmitter. The antenna(s), battery and accessories shall be those specified by the manufacturer. The EUT battery must be fully charged and checked periodically during the test to ascertain uniform power output. If a wireless link was used, the antenna connected to the output of the base station simulator shall be placed at least 50 cm away from the handset.

The signal transmitted by the simulator to the antenna feeding point should be lower than the output power level of the handset by at least 35 dB

### 6.2 SAR Measurement System

The SAR measurement system being used is the SATIMO system, the system is controlled remotely from a PC, which contains the software to control the robot and data acquisition equipment. The software also displays the data obtained from test scans.

In operation, the system first does an area (2D) scan at a fixed depth within the liquid from the inside wall of the phantom. When the maximum SAR point has been found, the system will then carry out a 3D scan centred at that point to determine volume averaged SAR level.

#### 6.2.1 Tissue Dielectric Parameters for Head and Body Phantoms

The head tissue dielectric parameters recommended by the IEEE SCC-34/SC-2 in P1528 have been incorporated in the following table. These head parameters are derived from planar layer models simulating the highest expected SAR for the dielectric properties and tissue thickness Power drifts in a human head. Other head and body tissue parameters that have not been specified in P1528 are derived from the tissue dielectric parameters computed from the 4-Cole-Cole equations described in Reference [12] and extrapolated according to the head parameters specified in P1528.

Table 1 Recommended Tissue Dielectric Parameters

Frequency (MHz)	Head Tissue		Body Tissue	
	$\epsilon_r$	$\sigma(S/m)$	$\epsilon_r$	$\sigma(S/m)$
150	52.3	0.76	61.9	0.80
300	45.3	0.87	58.2	0.92
450	43.5	0.87	56.7	0.94

835	41.5	0.90	55.2	0.97
900	41.5	0.97	55.0	1.05
915	41.5	0.98	55.0	1.06
1450	40.5	1.20	54.0	1.30
1610	40.3	1.29	53.8	1.40
1800-2000	40.0	1.40	53.3	1.52
2450	39.2	1.80	52.7	1.95
3000	38.5	2.40	52.0	2.73
5800	35.3	5.27	48.2	6.00

### 6.2.2 Stimulant liquids

For measurements against the phantom head, the “cheek” and “tilt” position on both the left hand and the right hand sides of the phantom. For body-worn measurements, the EUT was tested against flat phantom representing the user body. The EUT was put on in the belt holder. Stimulant liquids that are used for testing at frequencies of GSM 850MHz/1900MHz, which are made mainly of sugar, salt and water solutions may be left in the phantoms.

Table 2: Dielectric Performance of Head Tissue Simulating Liquid

Temperature: 23.2°C; Humidity: 64%;			
/	Frequency	Permittivity $\epsilon$	Conductivity $\sigma$ (S/m)
Target value	835MHz	41.5 $\pm$ 5%	0.90 $\pm$ 5%
Validation value (Sep. 14th, 2015)	835MHz	41.32	0.88
Target value	1900MHz	40.0 $\pm$ 5%	1.40 $\pm$ 5%
Validation value (Sep. 16th, 2015)	1900MHz	39.85	1.39

Table 3: Dielectric Performance of Body Tissue Simulating Liquid

Temperature: 23.2°C; Humidity: 64%;			
/	Frequency	Permittivity $\epsilon$	Conductivity $\sigma$ (S/m)
Target value	835MHz	55.2 $\pm$ 5%	0.97 $\pm$ 5%
Validation value (Sep. 14th, 2015)	835MHz	54.75	0.95
Target value	1900MHz	53.3 $\pm$ 5%	1.52 $\pm$ 5%
Validation value (Sep. 16th, 2015)	1900MHz	52.92	1.50

### 6.3 Results of validation testing

Prior to the assessment, the system validation kit was used to test whether the system was operating within its specifications of  $\pm 10\%$ . The validation results are tabulated below. And also the corresponding SAR plot is attached as well in the SAR plots files.

The following procedure, recommended for performing validation tests using box phantoms is based on the procedures described in the IEEE standard P1528. Setup according to the setup diagram below :

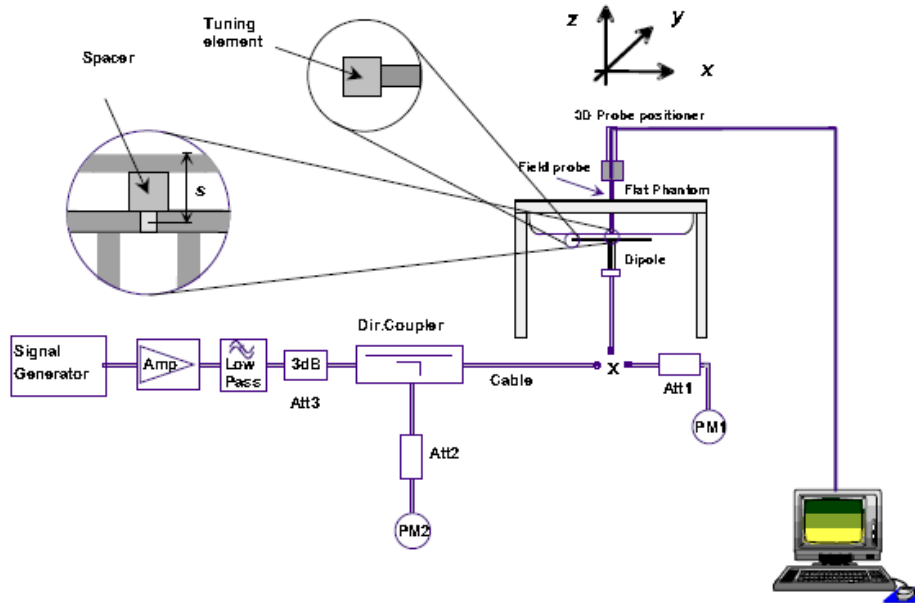

With the SG and Amp and with directional coupler in place, set up the source signal at the relevant frequency and use a power meter to measure the power at the end of the SMA cable that you intend to connect to the balanced dipole. Adjust the SG to make this, say, 0.25W (24 dBm). If this level is too high to read directly with the power meter sensor, insert a calibrated attenuator (e.g. 10 or 20 dB) and make a suitable correction to the power meter reading.

Note 1: In this method, the directional coupler is used for monitoring rather than setting the exact feed power level. If, however, the directional coupler is used for power measurement, you should check the frequency range and power rating of the coupler and measure the coupling factor (referred to output) at the test frequency using a VNA.

Note 2: Remember that the use of a 3dB attenuator (as shown in Figure 8.1 of P1528) means that you need an RF amplifier of 2 times greater power for the same feed power. The other issue is the cable length. You might get up to 1dB of loss per meter of cable, so the cable length after the coupler needs to be quite short.

Note 3: For the validation testing done using CW signals, most power meters are suitable. However, if you are measuring the output of a modulated signal from either a signal generator or a handset, you must ensure that the power meter correctly reads the modulated signals.

The measured 1-gram averaged SAR values of the device against the phantom are provided in Tables 5 and Table 6. The humidity and ambient temperature of test facility were 64% and 23.2°C respectively. The body phantom were full of the body tissue simulating liquid. The EUT was supplied with full-charged battery for each measurement.

The distance between the back of the EUT and the bottom of the flat phantom is 15 mm (taking into account of the IEEE 1528 and the place of the antenna).

Table 5: Head SAR system validation (1g)

Frequency	Duty cycle	Target value (W/kg)	Test value (W/kg)	
			250 mW	1W
835MHz(Sep. 14th, 2015)	1:1	9.77 ± 10%	2.42	9.68
1900MHz(Sep. 16th, 2015)	1:1	40.37 ± 10%	9.85	39.40

Table 6: Body SAR system validation (1g)

Frequency	Duty cycle	Target value (W/kg)	Test value (W/kg)	
			250 mW	1W
835MHz(Sep. 14th, 2015)	1:1	10.31 ± 10%	2.52	10.08
1900MHz(Sep. 16th, 2015)	1:1	40.81 ± 10%	10.13	40.52

\* Note: Target value was referring to the measured value in the calibration certificate of reference dipole.  
 Note: All SAR values are normalized to 1W forward power.

### 6.4 SAR measurement procedure

The SAR test against the head phantom was carried out as follow:

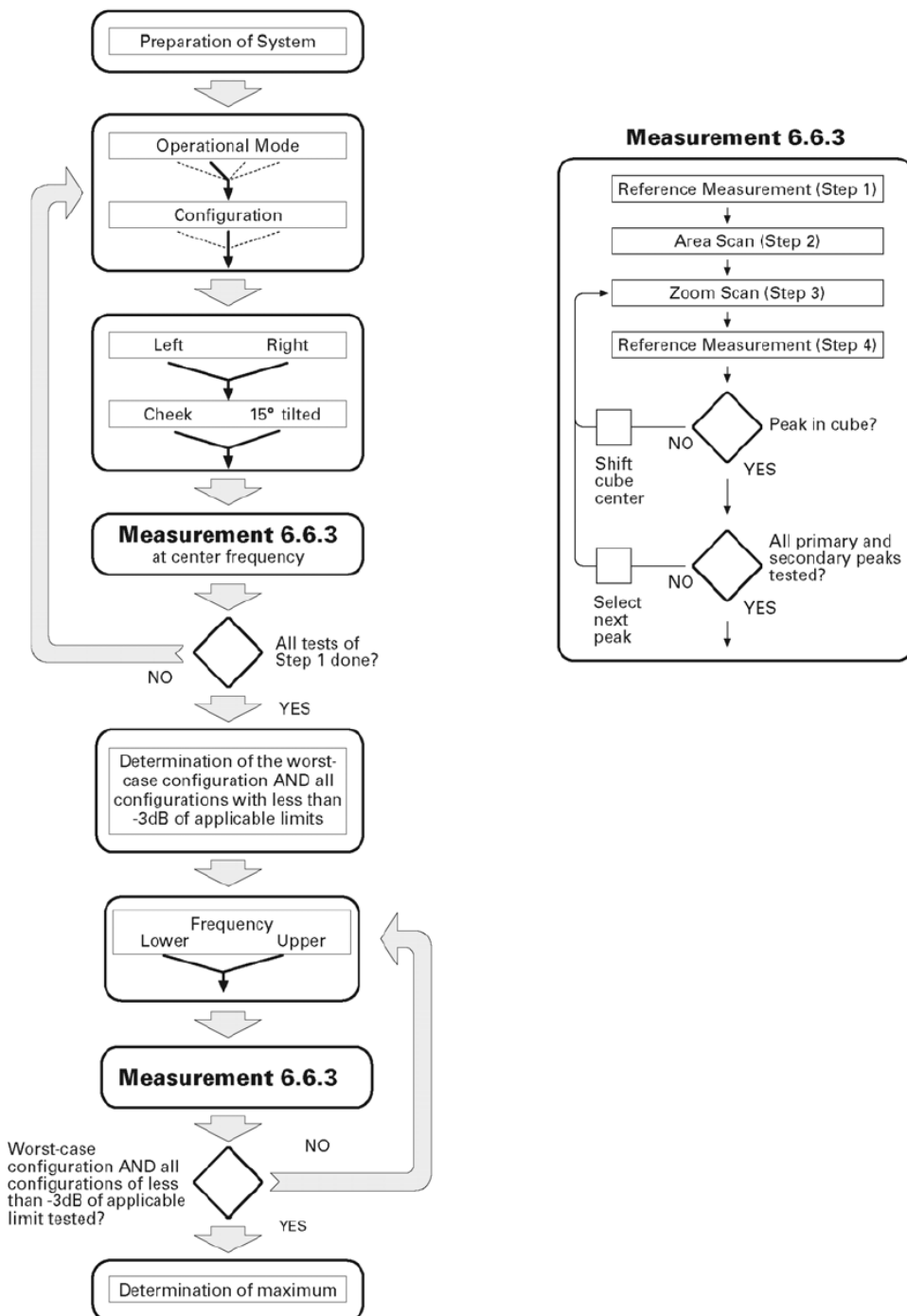

Establish a call with the maximum output power with a base station simulator, the connection between the EUT and the base station simulator is established via air interface.

After an area scan has been done at a fixed distance of 2mm from the surface of the phantom on the source side, a 3D scan is set up around the location of the maximum spot SAR. First, a point within the scan area is visited by the probe and a SAR reading taken at the start of testing. At the end of testing, the probe is returned to the same point and a second reading is taken. Comparison between these start and end readings enables the power drift during measurement to be assessed.

Above is the scanning procedure flow chart and table from the IEEE p1528 standard. This is the procedure for which all compliant testing should be carried out to ensure that all variations of the device position and transmission behavior are tested.

For body-worn measurement, the EUT was tested under two position: face upward and back upward.

### 6.5 Transmitting antenna information



Fig. 3 Position of the antennas



## 7 CHARACTERISTICS OF THE TEST

### 7.1 Applicable Limit Regulations

**47CFR § 2.1093-** Radiofrequency Radiation Exposure Evaluation: Portable Devices;

**ANSI C95.1–1992:** Safety Levels with Respect to Human Exposure to Radio Frequency Electromagnetic Fields, 3 kHz – 300 GHz.( IEEE Std C95.1-1991)

**IEEE 1528–2013:** IEEE Recommended Practice for Determining the Peak Spatial-Average Specific Absorption Rate (SAR) in the Human Body Due to Wireless Communications Devices: Experimental Techniques;

It specifies the maximum exposure limit of **1.6 W/kg** as averaged over any 1 gram of tissue for portable devices being used within 20 cm of the user in the uncontrolled environment.

### 7.2 Applicable Measurement Standards

The Specific Absorption Rate (SAR) testing specification, method, and procedure for this is in accordance with the following standards:

FCC 47 CFR Part2 (2.1093)

ANSI/IEEE C95.1-1992

IEEE 1528-2013

FCC KDB 447498 D01 v06 General RF Exposure Guidance

FCC KDB 648474 D04 v01r03 Handset SAR

FCC KDB 865664 D01 v01r04 SAR Measurement 100MHz to 6GHz

FCC KDB 865664 D02 v01r01 SAR Exposure Reporting

## 8 LABORATORY ENVIRONMENT

Table 9: The Ambient Conditions during SAR Test

Temperature	Min. = 22 ° C, Max. = 25 ° C
Atmospheric pressure	Min.=86 kPa, Max.=106 kPa
Relative humidity	Min. = 45%, Max. = 75%
Ground system resistance	< 0.5 Ω

Ambient noise is checked and found very low and in compliance with requirement of standards. Reflection of surrounding objects is minimized and in compliance with requirement of standards.

## 9. Conducted RF Output Power

### 9.1 GSM Conducted Power

Table 10: GSM Conducted Power

Band		Burst Average Power (dBm)			Frame-Average Power (dBm)		
GSM850	TX Channel	128	190	251	128	190	251
	Frequency(MHz)	824.2	836.4	848.8	824.2	836.4	848.8
	GSM	31.58	31.63	31.65	22.39	22.44	22.46
GSM1900	TX Channel	512	661	810	512	661	810
	Frequency(MHz)	1850.2	1880	1909.8	1850.2	1880	1909.8
	GSM	29.51	29.41	29.34	20.32	20.22	12.15

**Note:** Per KDB 447498 D01 v05r02, the maximum output power channel is used for SAR testing and for further SAR test reduction.

### Bluetooth Conducted Power

Channel	Frequency (MHz)	BT3.0 Output Power(dBm)		
		GFSK	$\pi$ /4-DQPSK	8-DPSK
CH 0	2402	2.29	2.21	1.97
CH 39	2441	2.30	2.15	1.85
CH 78	2480	2.42	2.11	1.89

Note:

- Per KDB 447498 D01v06, the 1-g and 10-g SAR test exclusion thresholds for 100MHz to 6GHz at test separation distances  $\leq 50$ mm are determined by: [(max. power of channel, including tune-up tolerance, mW)/(min. test separation distance, mm)]  $\cdot [\sqrt{f}$  (GHz)]  $\leq 3.0$  for 1-g SAR and  $\leq 7.5$  for 10-g extremity SAR
  - f(GHz) is the RF channel transmit frequency in GHz
  - Power and distance are round to the nearest mW and mm before calculation
  - The result is rounded to one decimal place for comparison
  - If the test separation distance(antenna-user) is  $< 5$ mm, 5mm is used for excluded SAR calculation

Bluetooth Max Power (dBm)	mW	Test Distance (mm)	Frequency(GHz)	Exclusion Thresholds
3	1.995	5	2.4	0.618

Per KDB 447498 D01v05r02 exclusion thresholds is  $0.618 < 3$ , RF exposure evaluation is not required.  
 BT estimated SAR value=Exclusion Thresholds/7.5= $0.618/7.5=0.082$ W/Kg

Bluetooth Max Power (dBm)	mW	Test Distance (mm)	Frequency(GHz)	Exclusion Thresholds
3	1.995	10	2.4	0.309

Per KDB 447498 D01v06 exclusion thresholds is  $0.703 < 3$ , RF exposure evaluation is not required.  
 BT estimated SAR value=Exclusion Thresholds/7.5= $0.309/7.5=0.041$ W/Kg  
 The estimated SAR value is used for simultaneous transmission analysis.





## General Note:

1. Per KDB 447498 D01v06, the reported SAR is the measured SAR value adjusted for maximum tune-up tolerance.
2. Per KDB447498 D01v06, testing of other required channels within the operating mode of a frequency band is not required when the reported 1-g or 10-g SAR for the mid-band or highest output power channel is:  $\leq 0.8$  W/kg or 2.0 W/kg, for 1-g or 10-g respectively, when the transmission band is  $\leq 100$  MHz. When the maximum output power variation across the required test channels is  $> \frac{1}{2}$  dB, instead of the middle channel, the highest output power channel must be used.
3. Per KDB 865664 D01v01r04, for each frequency band, repeated SAR measurement is required only when the measured SAR is  $\geq 0.8$  W/Kg; if the deviation among the repeated measurement is  $\leq 20\%$ , and the measured SAR  $< 1.45$  W/Kg, only one repeated measurement is required.
4. Per KDB865664 D02v01r01, SAR plot is only required for the highest measured SAR in each exposure configuration, wireless mode and frequency band combination; Plots are also required when the measured SAR is  $> 1.5$  W/kg, or  $> 7.0$  W/kg for occupational exposure. The published RF exposure KDB procedures may require additional plots; for example, to support SAR to peak location separation ratio test exclusion and/or volume scan post-processing (Refer to appendix D for details).



### 9.3. Scaling Factor calculation

Operation Mode	Channel	Output Power(dBm)	Tune up Power in tolerance(dBm)	Scaling Factor
GSM 850	128	31.58	31.50 ± 0.5	1.102
	190	31.63	31.50 ± 0.5	1.089
	251	31.65	31.50 ± 0.5	1.084
GSM1900	512	29.51	29.50± 0.5	1.119
	661	29.41	29.50± 0.5	1.146
	810	29.34	29.50± 0.5	1.164
BT	78	2.42	2.00± 1.0	1.143

### Simultaneous SAR

No.	Transmitter Combinations	Scenario Supported or not	Supported for Mobile Hotspot or not
1	GSM(Voice)+GSM(Data)	No	No
2	GSM(Voice)+ BT	Yes	No



## 10 TEST RESULTS

### 10.1 Summary of SAR Measurement Results

Table 7: SAR Values of GSM 850MHz Band

Temperature: 23.0~23.5°C, humidity: 62~64%.				
Test Positions		Channel /Frequency (MHz)	SAR(W/Kg), 1.6 (1g average)	
			SAR(W/Kg),1g	Scaled SAR(W/Kg),1g
Right Side of Head	Cheek	251/848.8	0.541	0.586
	Tilt 15 degrees	251/848.8	0.426	0.462
Left Side of Head	Cheek	251/848.8	<b>0.556</b>	<b>0.603</b>
	Tilt 15 degrees	251/848.8	0.386	0.418
Body-worn (15mm Separation)	GSM	Face Upward	251/848.8	0.231
		Back Upward	251/848.8	<b>0.269</b>

Table 8: SAR Values of GSM1900 MHz Band

Temperature: 23.0~23.5°C, humidity: 62~64%.				
Test Positions		Channel /Frequency (MHz)	SAR(W/Kg), 1.6 (1g average)	
			SAR(W/Kg),1g	Scaled SAR(W/Kg),1g
Right Side of Head	Cheek	512/1850.2	<b>0.250</b>	<b>0.280</b>
	Tilt 15 degrees	512/1850.2	0.097	0.109
Left Side of Head	Cheek	512/1850.2	0.167	0.187
	Tilt 15 degrees	512/1850.2	0.091	0.102
Body-worn (15mm Separation)	GSM	Face Upward	512/1850.2	0.214
		Back Upward	512/1850.2	<b>0.263</b>

Note: When the 1-g SAR for the mid-band channel or the channel with the Highest output power satisfy the following conditions, testing of the other channels in the band is not required.(Per KDB 447498 D01 General RF Exposure Guidance v05r02)

- $\leq 0.8$  W/kg, when the transmission band is  $\leq 100$  MHz
- $\leq 0.6$  W/kg, when the transmission band is between 100 MHz and 200 MHz
- $\leq 0.4$  W/kg, when the transmission band is  $\geq 200$  MHz

### 10.2 Conclusion

Localized Specific Absorption Rate (SAR) of this portable wireless device has been measured in all cases requested by the relevant standards cited in Clause 6 of this report. Maximum localized SAR is **below** exposure limits specified in the relevant standards.

**SIMULTANEOUS TRANSMISSION ANALYSIS**

Test Position		Right Cheek	Right Title	Left Cheek	Left Tilt
Head MAX 1-g SAR(W/Kg)	GSM850	0.586	0.462	0.603	0.418
	GSM1900	0.280	0.109	0.187	0.102
	BT	*0.082	*0.082	*0.082	*0.082
BT Simultaneous $\Sigma$ 1-g SAR(W/Kg)		0.668	0.544	0.685	0.500

Simultaneous Tx Combination of GSM/WCDMA and BT (Head).

Test Position		Face	Back	Edge A	Edge B	Edge C	Edge D
Body-worn 10mm separation MAX 1-g SAR(W/Kg)	GSMS850	0.250	0.292	--	--	--	--
	GSM1900	0.239	0.294	--	--	--	--
	BT	*0.041	*0.041	--	--	--	--
BT Simultaneous $\Sigma$ 1-g SAR(W/Kg)		0.291	0.333	--	--	--	--

Simultaneous Tx Combination of GSM/WCDMA and BT (Body).

The estimated SAR value with \* Signal

**SAR to Peak Location Separation Ratio (SPLSR)**

As the Sum of the SAR is not greater than 1.6 W/kg SPLSR assessment is not required

## 11 Measurement Uncertainty

No.	Uncertainty Component	Type	Uncertainty Value (%)	Probability Distribution	k	ci	Standard Uncertainty (%) $u_i(\%)$	Degree of freedom $\nu_{eff}$ or $\nu_i$
<b>Measurement System</b>								
1	–Probe Calibration	B	5.8	N	1	1	5.8	$\infty$
2	–Axial isotropy	B	3.5	R	$\sqrt{3}$	0.5	1.43	$\infty$
3	–Hemispherical Isotropy	B	5.9	R	$\sqrt{3}$	0.5	2.41	$\infty$
4	–Boundary Effect	B	1	R	$\sqrt{3}$	1	0.58	$\infty$
5	–Linearity	B	4.7	R	$\sqrt{3}$	1	2.71	$\infty$
6	–System Detection Limits	B	1.0	R	$\sqrt{3}$	1	0.58	$\infty$
7	Modulation response	B	3	N	1	1	3.00	
8	–Readout Electronics	B	0.5	N	1	1	0.50	$\infty$
9	–Response Time	B	1.4	R	$\sqrt{3}$	1	0.81	$\infty$
10	–Integration Time	B	3.0	R	$\sqrt{3}$	1	1.73	$\infty$
11	–RF Ambient Conditions	B	3.0	R	$\sqrt{3}$	1	1.73	$\infty$
12	–Probe Position Mechanical tolerance	B	1.4	R	$\sqrt{3}$	1	0.81	$\infty$
13	–Probe Position with respect to Phantom Shell	B	1.4	R	$\sqrt{3}$	1	0.81	$\infty$
14	–Extrapolation, Interpolation and Integration Algorithms for Max. SAR evaluation	B	2.3	R	$\sqrt{3}$	1	1.33	$\infty$
<b>Uncertainties of the DUT</b>								
15	–Position of the DUT	A	2.6	N	$\sqrt{3}$	1	2.6	5
16	–Holder of the DUT	A	3	N	$\sqrt{3}$	1	3.0	5



17	–Output Power Variation –SAR drift measurement	B	5.0	R	$\sqrt{3}$	1	2.89	$\infty$
<b>Phantom and Tissue Parameters</b>								
18	– Phantom Uncertainty(shape and thickness tolerances)	B	4	R	$\sqrt{3}$	1	2.31	$\infty$
19	Uncertainty in SAR correction for deviation(in permittivity and conductivity)	B	2	N	1	1	2.00	
20	–Liquid Conductivity Target –tolerance	B	2.5	R	$\sqrt{3}$	0.6	1.95	$\infty$
21	–Liquid Conductivity –measurement Uncertainty)	B	4	N	$\sqrt{3}$	1	0.92	9
22	–Liquid Permittivity Target tolerance	B	2.5	R	$\sqrt{3}$	0.6	1.95	$\infty$
23	–Liquid Permittivity –measurement uncertainty	B	5	N	$\sqrt{3}$	1	1.15	$\infty$
<b>Combined Standard Uncertainty</b>				RSS			10.63	
<b>Expanded uncertainty</b> (Confidence interval of 95 %)				K=2			21.26	

### System Check Uncertainty

No.	Uncertainty Component	Type	Uncertainty Value (%)	Probability Distribution	k	ci	Standard Uncertainty (%) $u_i(\%)$	Degree of freedom $v_{eff}$ or $v_i$
<b>Measurement System</b>								
1	–Probe Calibration	B	5.8	N	1	1	5.8	$\infty$
2	–Axial isotropy	B	3.5	R	$\sqrt{3}$	0.5	1.43	$\infty$
3	–Hemispherical Isotropy	B	5.9	R	$\sqrt{3}$	0.5	2.41	$\infty$
4	–Boundary Effect	B	1	R	$\sqrt{3}$	1	0.58	$\infty$
5	–Linearity	B	4.7	R	$\sqrt{3}$	1	2.71	$\infty$
6	–System Detection Limits	B	1	R	$\sqrt{3}$	1	0.58	$\infty$
7	Modulation response	B	0	N	1	1	0.00	



8	–Readout Electronics	B	0.5	N	1	1	0.50	∞
9	–Response Time	B	0.00	R	$\sqrt{3}$	1	0.00	∞
10	–Integration Time	B	1.4	R	$\sqrt{3}$	1	0.81	∞
11	–RF Ambient Conditions	B	3.0	R	$\sqrt{3}$	1	1.73	∞
12	–Probe Position Mechanical tolerance	B	1.4	R	$\sqrt{3}$	1	0.81	∞
13	–Probe Position with respect to Phantom Shell	B	1.4	R	$\sqrt{3}$	1	0.81	∞
14	–Extrapolation, Interpolation and Integration Algorithms for Max. SAR evaluation	B	2.3	R	$\sqrt{3}$	1	1.33	∞
<b>Uncertainties of the DUT</b>								
15	Deviation of experimental source from numerical source	A	4	N	1	1	4.00	5
16	Input Power and SAR drift measurement	A	5	R	$\sqrt{3}$	1	2.89	5
17	Dipole Axis to Liquid Distance	B	2	R	$\sqrt{3}$	1	1.2	∞
<b>Phantom and Tissue Parameters</b>								
18	–Phantom Uncertainty(shape and thickness tolerances)	B	4	R	$\sqrt{3}$	1	2.31	∞
19	Uncertainty in SAR correction for deviation(in permittivity and conductivity)	B	2	N	1	1	2.00	
20	–Liquid Conductivity Target –tolerance	B	2.5	R	$\sqrt{3}$	0.6	1.95	∞
21	–Liquid Conductivity –measurement Uncertainty)	B	4	N	$\sqrt{3}$	1	0.92	9
22	–Liquid Permittivity Target tolerance	B	2.5	R	$\sqrt{3}$	0.6	1.95	∞
23	–Liquid Permittivity –measurement uncertainty	B	5	N	$\sqrt{3}$	1	1.15	∞
<b>Combined Standard Uncertainty</b>					RSS		10.15	
<b>Expanded uncertainty</b> (Confidence interval of 95 %)					K=2		20.29	

**12 MAIN TEST INSTRUMENTS**

<b>No.</b>	<b>EQUIPMENT</b>	<b>TYPE</b>	<b>Series No.</b>	<b>Due Date</b>
1	System Simulator	E5515C	GB 47200710	2016/06/10
2	SAR Probe	SATIMO	SN_0413_EP166	2016/08/10
3	Dipole	SID835	SN09/13 DIPOG835-217	2016/08/26
5	Dipole	SID1900	SN09/13 DIP1G900-218	2016/08/26
6	Vector Network Analyzer	ZVB8	A0802530	2016/06/08
7	Signal Generator	SMR27	A0304219	2016/06/08
8	Power Meter	NRP2	A140401673	2016/03/27
9	Power Sensor	NPR-Z11	1138.3004.02-114072-nq	2016/03/27
10	Amplifier	Nucletudes	143060	2016/03/27
11	Directional Coupler	DC6180A	305827	2016/03/27
12	Power Meter	NRVS	A0802531	2016/03/27
13	Power Sensor	NRV-Z4	100069	2016/03/27
14	Multimeter	Keithley-2000	4014020	2016/03/27





**ANNEX A**

**of**

**CCIC-SET**

**CONFORMANCE TEST REPORT FOR**

**HUMAN EXPOSURE TO ELECTROMAGNETIC FIELDS**

**SET2015-13711**

**Punkt.**

**Type Name: MP 01**

**Hardware Version: V1.2**

**Software Version: M60A\_A201\_082\_V26**

**TEST LAYOUT**

**This Annex consists of 5 pages**

**Date of Report: 2015-09-25**

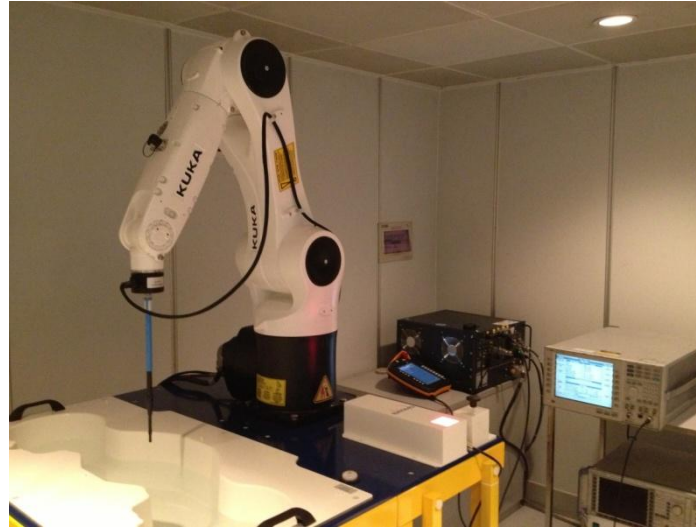

**Fig.1 COMO SAR Test System**

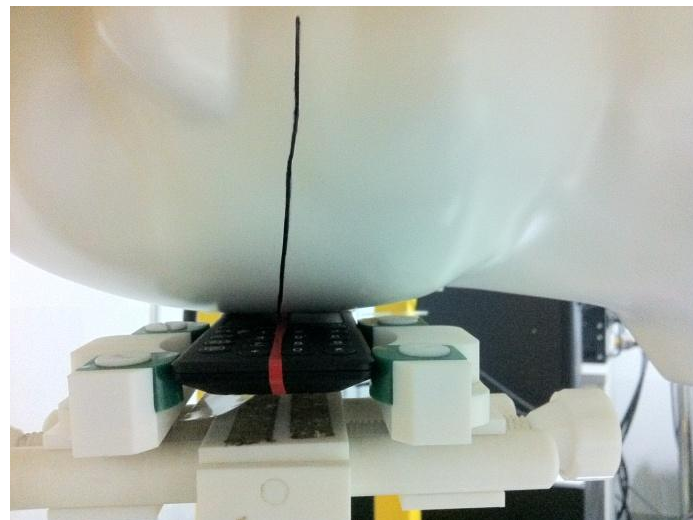

**Fig.2 Right\_Cheek**

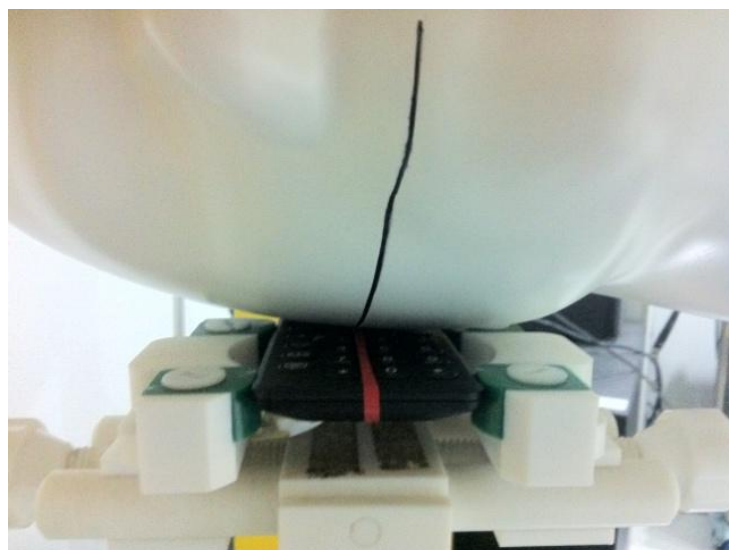

**Fig.3 Right\_Tilt**

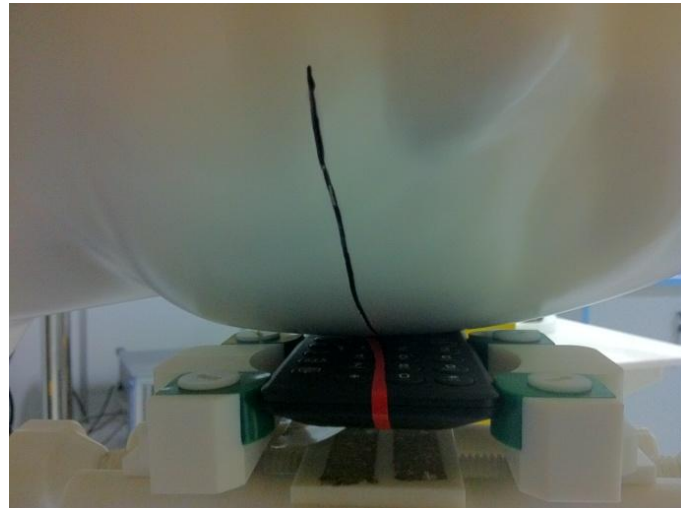

**Fig.4 Left Cheek**

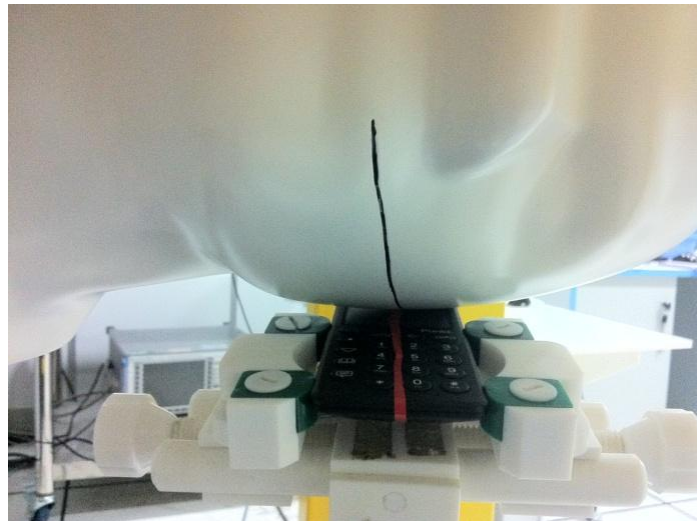

**Fig.5 Left\_Tilt**

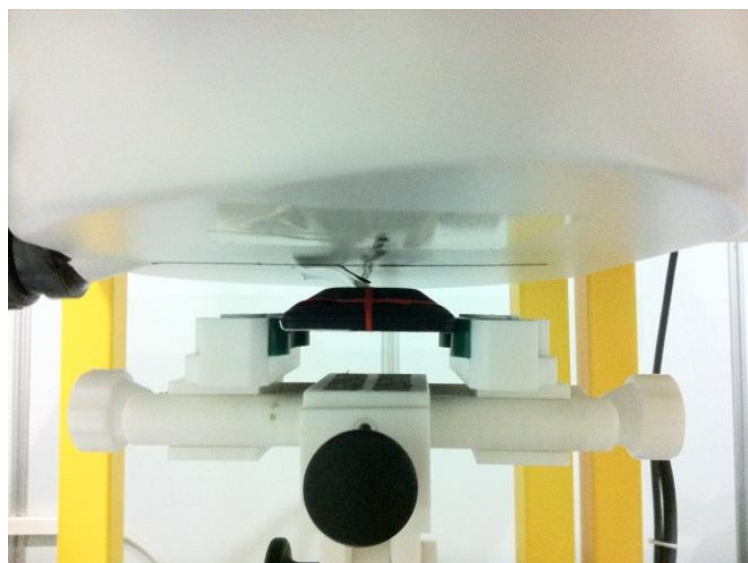

**Fig.6 Body (Back upside,15mm separation)**

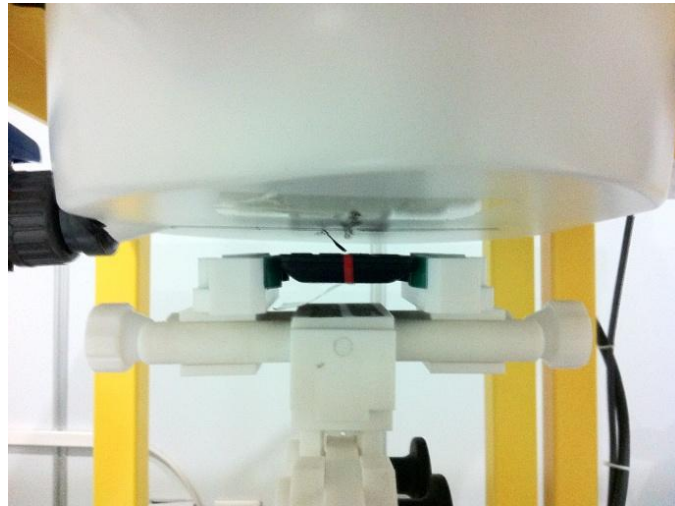

**Fig.7 Body (Face upside, 15mm separation)**



**Fig.8 Head Liquid of 835MHz(15cm)**



**Fig.9 Body Liquid of 835MHz(15cm)**



**Fig.10 Head Liquid of 1900MHz(15cm)**



**Fig.11 Body Liquid of 1900MHz(15cm)**



**ANNEX B**

**of**

**CCIC-SET**

**CONFORMANCE TEST REPORT FOR**

**HUMAN EXPOSURE TO ELECTROMAGNETIC FIELDS**

**SET2015-13711**

**Punkt.**

**Type Name: MP 01**

**Hardware Version: V1.2**

**Software Version: M60A\_A201\_082\_V26**

**Sample Photographs**

**This Annex consists of 2 pages**

**Date of Report: 2015-09-25**

### 1. Appearance



Appearance and size (obverse)

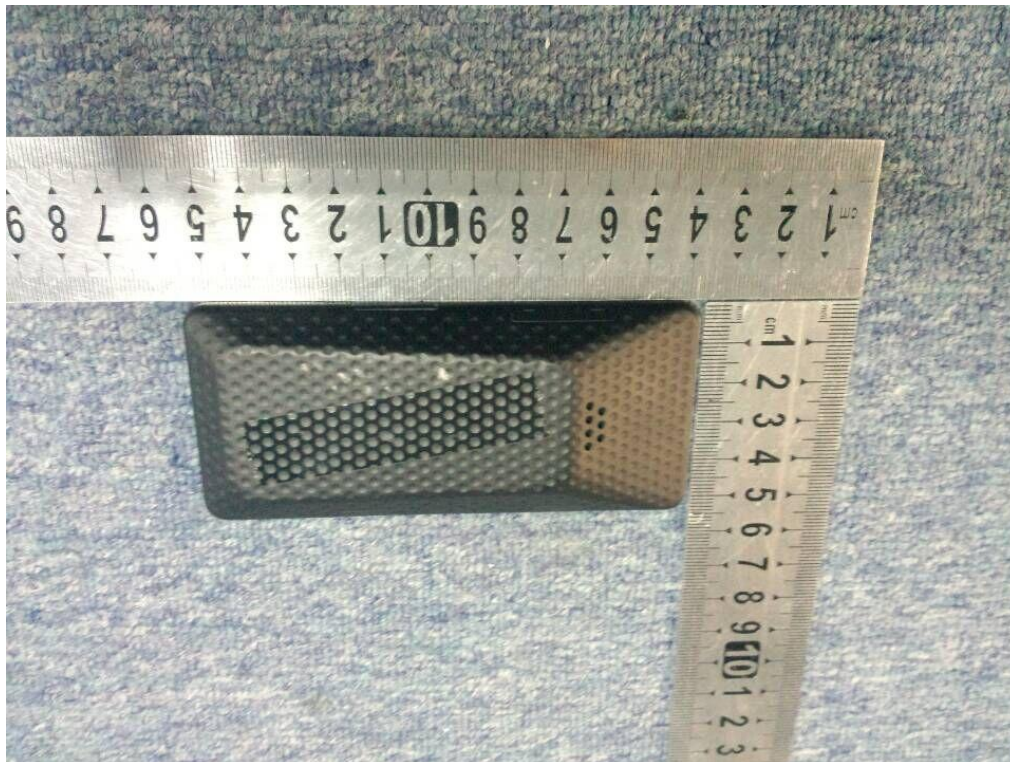

Appearance and size (reverse)



**ANNEX C**

**of**

**CCIC-SET**

**CONFORMANCE TEST REPORT FOR**

**HUMAN EXPOSURE TO ELECTROMAGNETIC FIELDS**

**SET2015-13711**

**Punkt.**

**Type Name: MP 01**

**Hardware Version: V1.2**

**Software Version: M60A\_A201\_082\_V26**

**System Performance Check Data and Highest SAR Plots**

**This Annex consists of 13 pages**

**Date of Report: 2015-09-25**



## System Performance Check (Head, 835MHz)

Type: Validation measurement

Area scan resolution: dx=8mm,dy=8mm

Zoom scan resolution: dx=8mm, dy=8mm, dz=5mm

Date of measurement:14/09/2015

Measurement duration: 21 minutes 24 seconds

### A. Experimental conditions.

<b>Phantom File</b>	surf_sam_plan.txt
<b>Phantom</b>	Flat Plane
<b>Device Position</b>	
<b>Band</b>	835MHz
<b>Channels</b>	
<b>Signal</b>	CW

### B. SAR Measurement Results

#### Band SAR

<b>E-Field Probe</b>	SATIMO SN_04/13_EP166
<b>Frequency (MHz)</b>	835
<b>Relative permittivity (real part)</b>	41.32
<b>Relative permittivity</b>	18.97
<b>Conductivity (S/m)</b>	0.88
<b>Power drift (%)</b>	1.23
<b>Ambient Temperature:</b>	23.2 °C
<b>Liquid Temperature:</b>	23.5 °C
<b>ConvF:</b>	5.69
<b>Duty factor:</b>	1:1

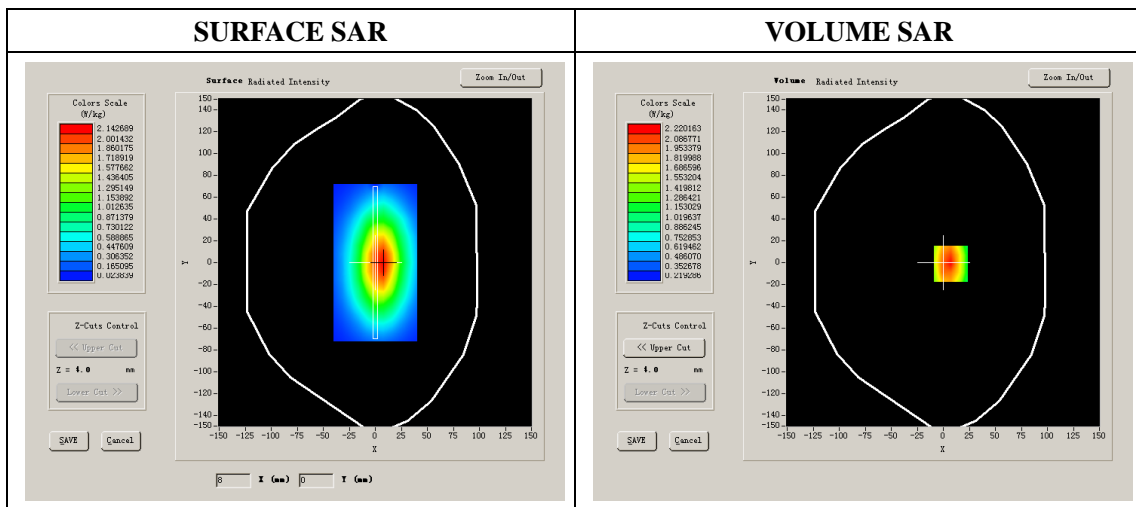

**Maximum location: X=7.00, Y=-1.00**

<b>SAR 10g (W/Kg)</b>	1.820846
<b>SAR 1g (W/Kg)</b>	2.423842

## System Performance Check (Head, 1900MHz)

Type: Validation measurement

Area scan resolution: dx=8mm,dy=8mm

Zoom scan resolution: dx=8mm, dy=8mm, dz=5mm

Date of measurement: 16/09/2015

Measurement duration: 20 minutes 57 seconds

### A. Experimental conditions.

<b>Phantom File</b>	surf_sam_plan.txt
<b>Phantom</b>	Flat Plane
<b>Device Position</b>	
<b>Band</b>	1900MHz
<b>Channels</b>	
<b>Signal</b>	CW

### B. SAR Measurement Results

#### Band SAR

<b>E-Field Probe</b>	SATIMO SN_04/13_EP166
<b>Frequency (MHz)</b>	1900
<b>Relative permittivity (real part)</b>	39.85
<b>Relative permittivity</b>	13.17
<b>Conductivity (S/m)</b>	1.39
<b>Power drift (%)</b>	-0.42
<b>Ambient Temperature:</b>	22.2 °C
<b>Liquid Temperature:</b>	22.5 °C
<b>ConvF:</b>	5.25
<b>Duty factor:</b>	1:1

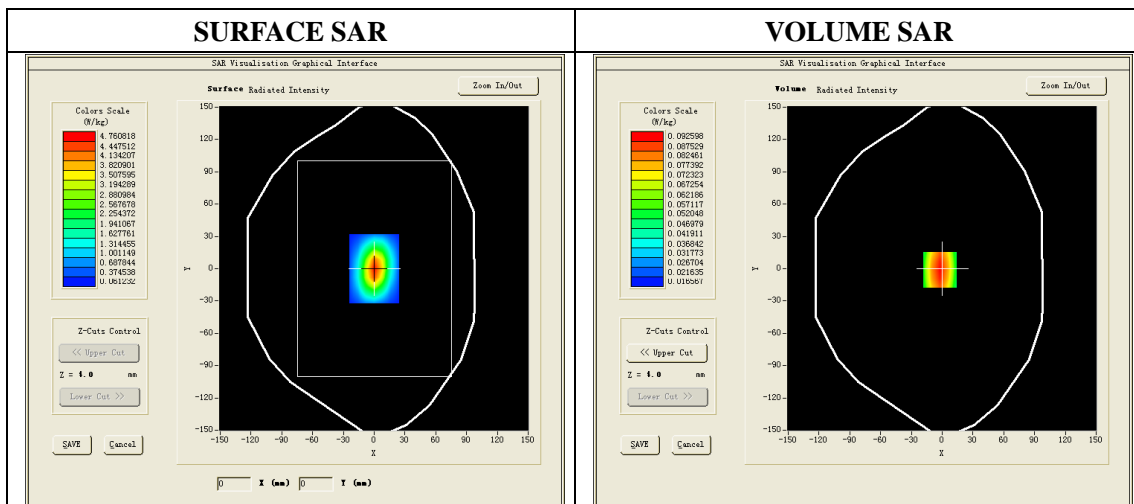

**Maximum location: X=6.00, Y=0.00**

<b>SAR 10g (W/Kg)</b>	5.152174
<b>SAR 1g (W/Kg)</b>	9.854350

## System Performance Check (Body, 835MHz)

Type: Validation measurement

Area scan resolution: dx=8mm,dy=8mm

Zoom scan resolution: dx=8mm, dy=8mm, dz=5mm

Date of measurement: 14/09/2015

Measurement duration: 20 minutes 12 seconds

### A. Experimental conditions.

<b>Phantom File</b>	surf_sam_plan.txt
<b>Phantom</b>	Flat Plane
<b>Device Position</b>	Dipole
<b>Band</b>	835MHz
<b>Channels</b>	
<b>Signal</b>	CW

### B. SAR Measurement Results

#### Band SAR

<b>E-Field Probe</b>	SATIMO SN_04/13_EP166
<b>Frequency (MHz)</b>	835
<b>Relative permittivity (real part)</b>	54.75
<b>Relative permittivity</b>	20.48
<b>Conductivity (S/m)</b>	0.95
<b>Power drift (%)</b>	2.30
<b>Ambient Temperature:</b>	22.2 °C
<b>Liquid Temperature:</b>	22.5 °C
<b>ConvF:</b>	5.82
<b>Duty factor:</b>	1:1

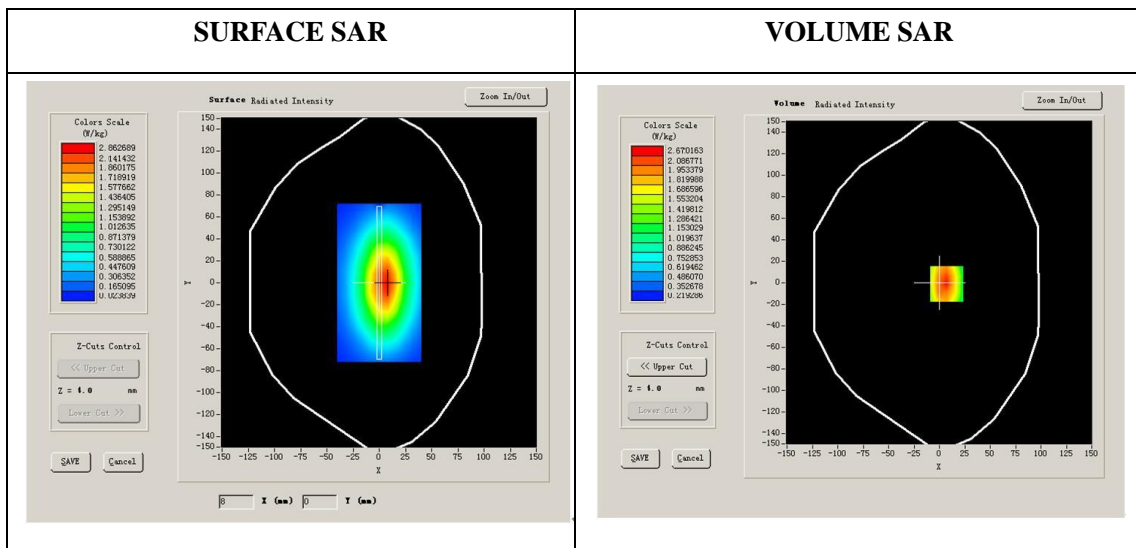

**Maximum location: X=7.00, Y=-1.00**

<b>SAR 10g (W/Kg)</b>	1.604238
<b>SAR 1g (W/Kg)</b>	2.521327

## System Performance Check (Body, 1900MHz)

Type: Validation measurement

Area scan resolution: dx=8mm,dy=8mm

Zoom scan resolution: dx=8mm, dy=8mm, dz=5mm

Date of measurement: 16/09/2015

Measurement duration: 21 minutes 34 seconds

### A. Experimental conditions.

<b>Phantom File</b>	surf_sam_plan.txt
<b>Phantom</b>	Validation plane
<b>Device Position</b>	Dipole
<b>Band</b>	1900MHz
<b>Channels</b>	
<b>Signal</b>	CW

### B. SAR Measurement Results

Band SAR

<b>E-Field Probe</b>	SATIMO SN_04/13_EP166
<b>Frequency (MHz)</b>	1900
<b>Relative permittivity (real part)</b>	52.92
<b>Relative permittivity</b>	14.21
<b>Conductivity (S/m)</b>	1.50
<b>Power Drift (%)</b>	3.21
<b>Ambient Temperature:</b>	22.1 °C
<b>Liquid Temperature:</b>	22.6 °C
<b>ConvF:</b>	5.43
<b>Duty factor:</b>	1:1

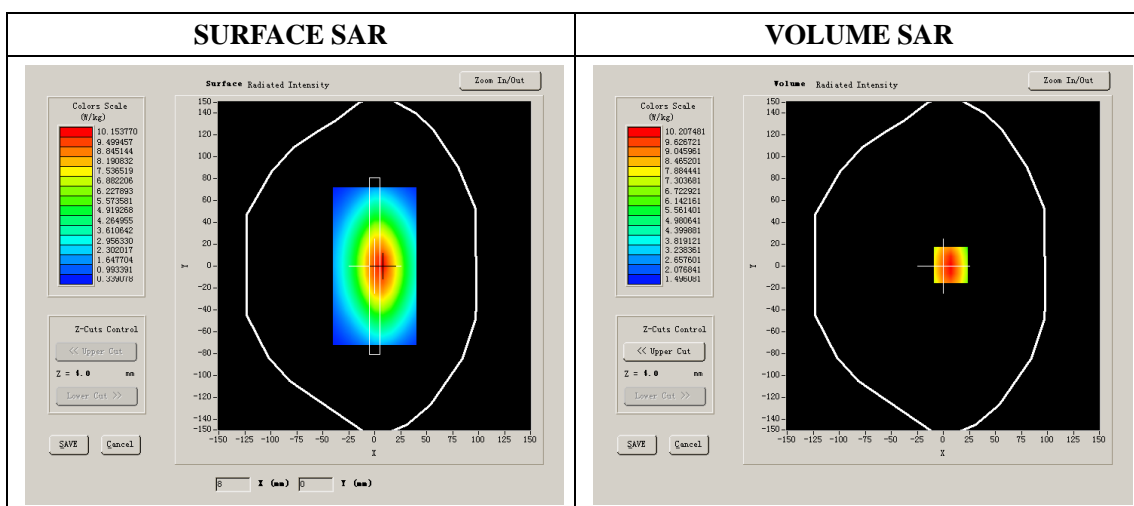

**Maximum location: X=1.00, Y=6.00**

<b>SAR 10g (W/Kg)</b>	5.283723
<b>SAR 1g (W/Kg)</b>	10.130854

# GSM850, Left Cheek, High

Type: Phone measurement  
 Date of measurement: 14/09/2015  
 Measurement duration: 6 minutes 37 seconds  
 Mobile Phone IMEI number: --

### A. Experimental conditions.

<b>Area Scan</b>	dx=8mm dy=8mm
<b>ZoomScan</b>	5x5x7,dx=8mm dy=8mm dz=5mm
<b>Phantom</b>	Left head
<b>Device Position</b>	Cheek
<b>Band</b>	GSM850
<b>Channels</b>	251
<b>Signal</b>	GSM (Duty cycle: 1:8)

### B. SAR Measurement Results

<b>E-Field Probe</b>	SATIMO SN_04/13_EP166
<b>Frequency (MHz)</b>	848.8
<b>Relative permittivity (real part)</b>	41.35
<b>Relative permittivity (imaginary part)</b>	18.97
<b>Conductivity (S/m)</b>	0.89
<b>Variation (%)</b>	-3.15
<b>ConvF:</b>	5.69

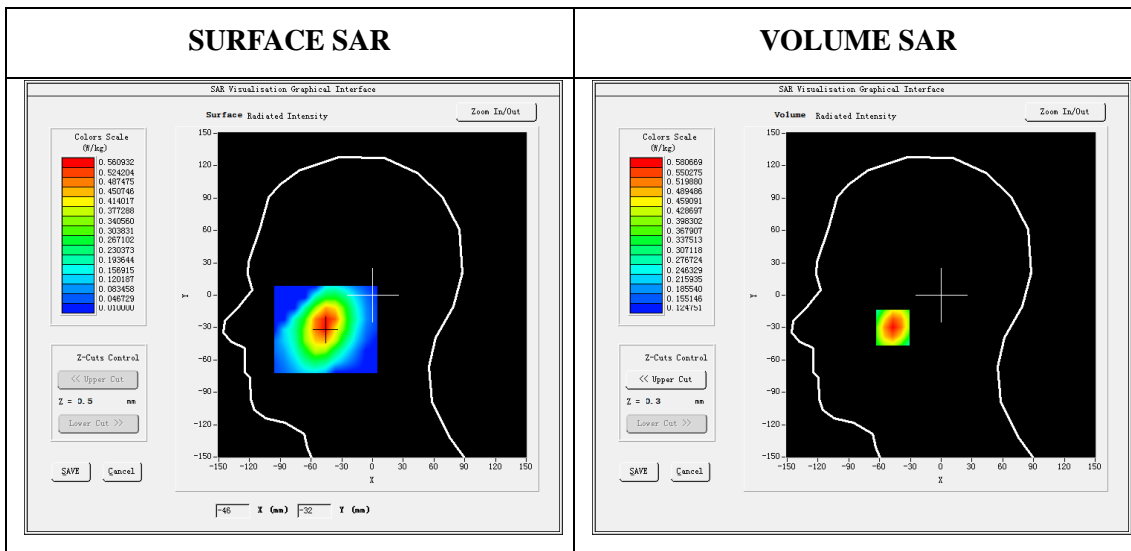

**Maximum location: X=-47.00, Y=-30.00**

<b>SAR 10g (W/Kg)</b>	0.414030
<b>SAR 1g (W/Kg)</b>	0.555993

Z (mm)	0.00	4.00	9.00	14.00	19.00
SAR (W/Kg)	0.6957	0.5807	0.4679	0.3844	0.3227

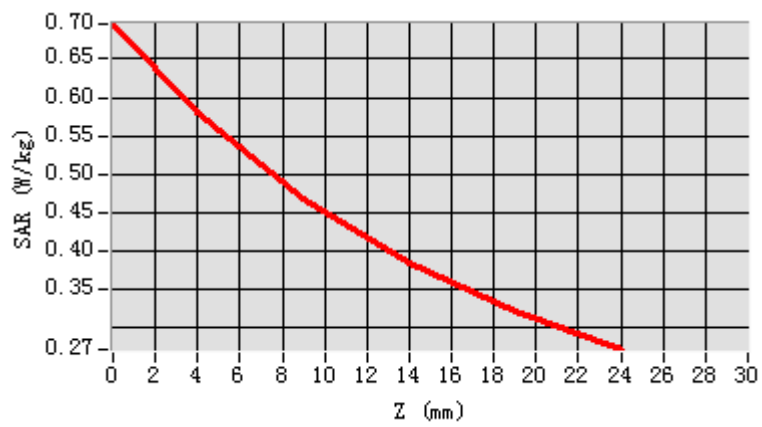

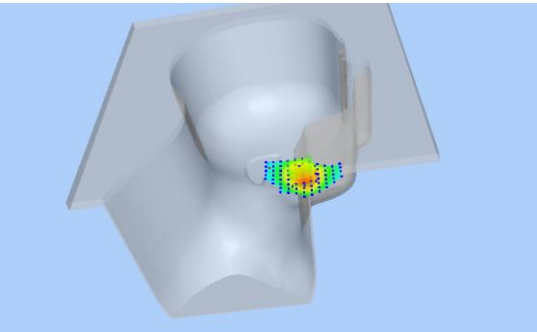
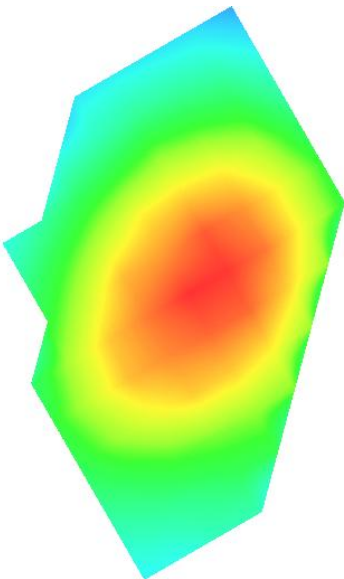
3D screen shot	Hot spot position
	

# GSM850, Back, High

Type: Phone measurement

Date of measurement: 14/09/2015

Measurement duration: 7 minutes 12 seconds

Mobile Phone IMEI number: --

## A. Experimental conditions.

<b>Area Scan</b>	dx=8mm dy=8mm
<b>ZoomScan</b>	5x5x7,dx=8mm dy=8mm dz=5mm
<b>Phantom</b>	Validation plane
<b>Device Position</b>	Back
<b>Band</b>	GSM850
<b>Channels</b>	251
<b>Signal</b>	GSM(Duty cycle: 1:8)

## B. SAR Measurement Results

<b>E-Field Probe</b>	SATIMO SN_04/13_EP166
<b>Frequency (MHz)</b>	848.8
<b>Relative permittivity (real part)</b>	54.78
<b>Relative permittivity (imaginary part)</b>	20.48
<b>Conductivity (S/m)</b>	0.95
<b>Variation (%)</b>	2.16
<b>ConvF:</b>	5.82

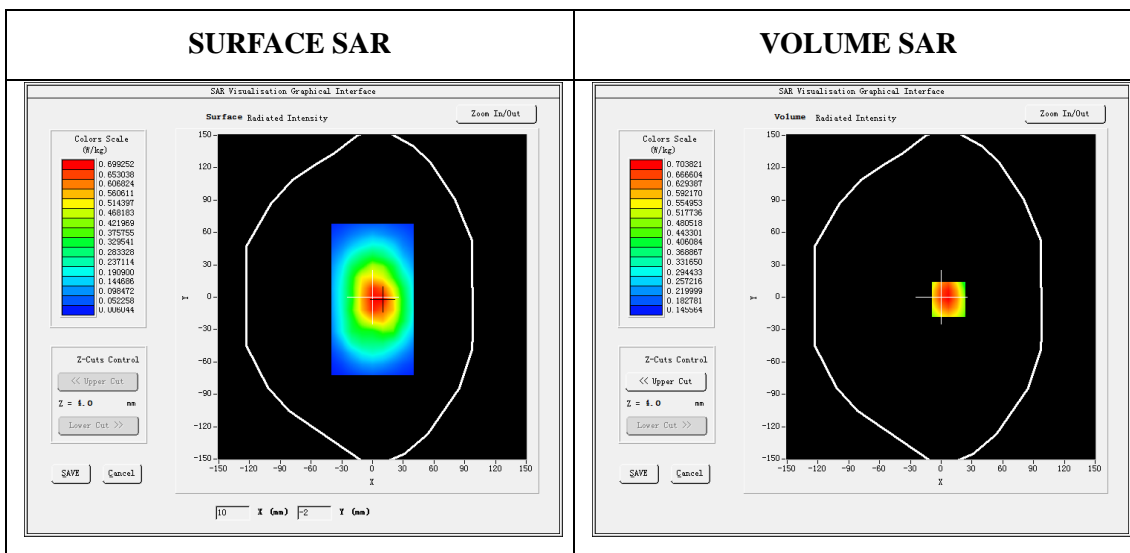

**Maximum location: X=7.00, Y=-2.00**

<b>SAR 10g (W/Kg)</b>	0.133919
<b>SAR 1g (W/Kg)</b>	0.269496

Z (mm)	0.00	4.00	9.00	14.00	19.00
SAR (W/Kg)	0.8035	0.6038	0.4810	0.3625	0.2519

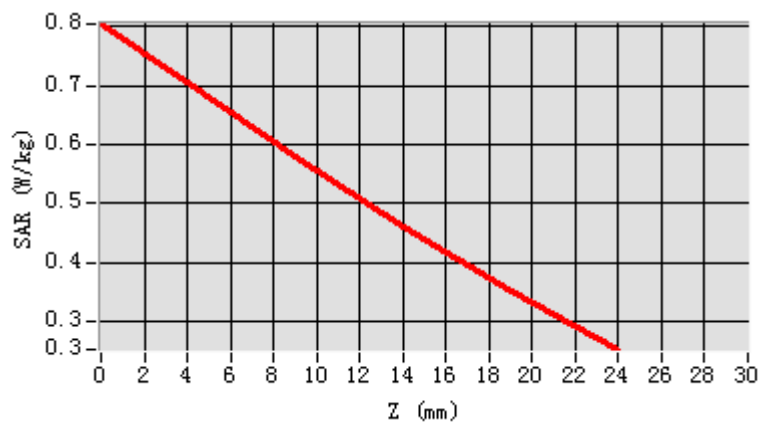

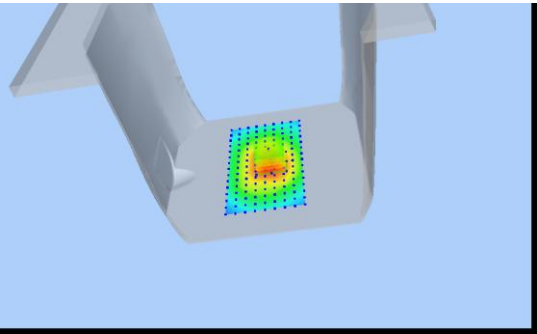
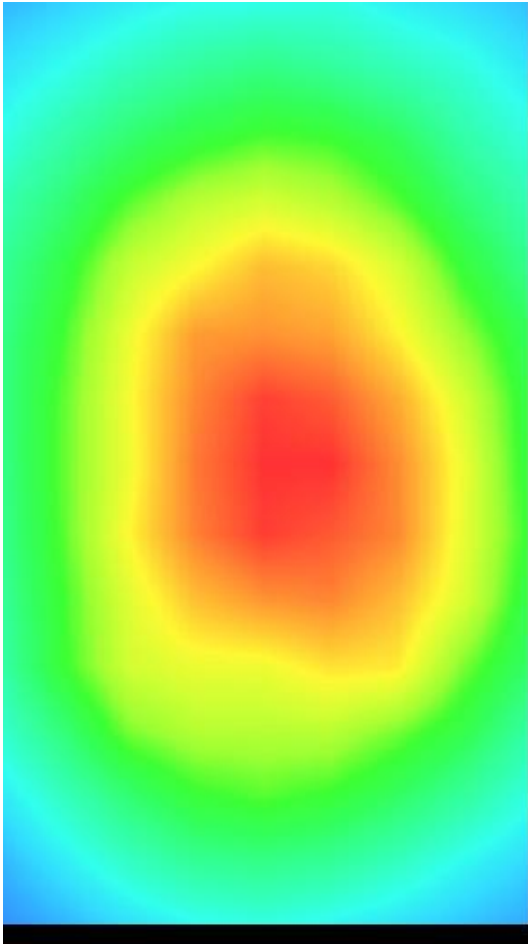
3D screen shot	Hot spot position
	



# GSM1900, Right Cheek, Low

Type: Phone measurement

Date of measurement: 16/09/2015

Measurement duration: 7 minutes 03 seconds

Mobile Phone IMEI number: --

## A. Experimental conditions.

<b>Area Scan</b>	dx=8mm dy=8mm
<b>ZoomScan</b>	5x5x7,dx=8mm dy=8mm dz=5mm
<b>Phantom</b>	Right Head
<b>Device Position</b>	Cheek
<b>Band</b>	GSM1900
<b>Channels</b>	512
<b>Signal</b>	GSM (Duty cycle: 1:8)

## B. SAR Measurement Results

<b>E-Field Probe</b>	SATIMO SN_04/13_EP166
<b>Frequency (MHz)</b>	1850.2
<b>Relative permittivity (real part)</b>	39.84
<b>Relative permittivity (imaginary part)</b>	13.17
<b>Conductivity (S/m)</b>	1.39
<b>Variation (%)</b>	-4.09
<b>ConvF:</b>	5.25

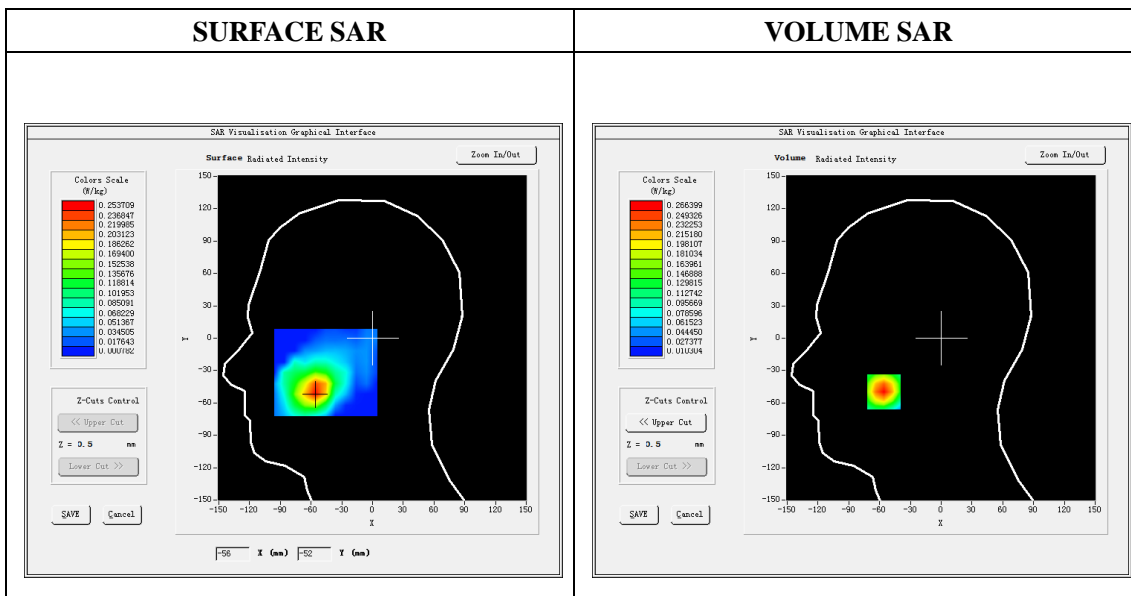

**Maximum location: X=-56.00, Y=-50.00**

<b>SAR 10g (W/Kg)</b>	0.152235
<b>SAR 1g (W/Kg)</b>	0.249617

Z (mm)	0.00	4.00	9.00	14.00	19.00
SAR (W/Kg)	0.3532	0.2664	0.1851	0.1276	0.0872

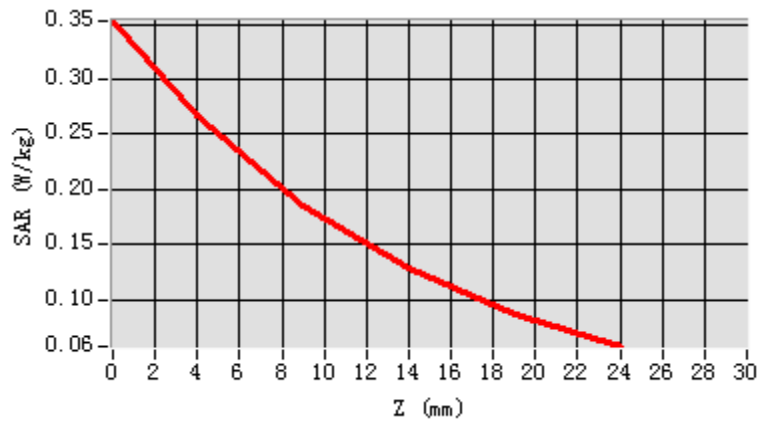

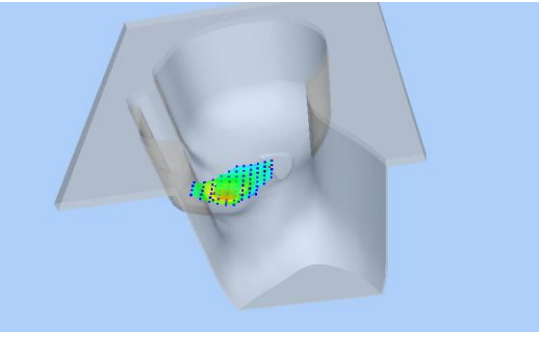
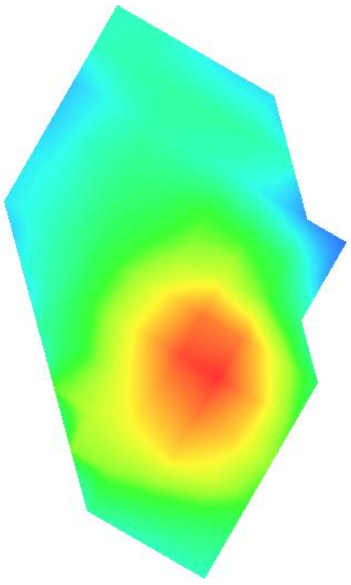
3D screen shot	Hot spot position
	

# GSM1900, Back, Low

Type: Phone measurement  
 Date of measurement: 16/09/2015  
 Measurement duration: 6 minutes 52 seconds  
 Mobile Phone IMEI number: --

## A. Experimental conditions.

<b>Area Scan</b>	dx=8mm dy=8mm
<b>ZoomScan</b>	5x5x7,dx=8mm dy=8mm dz=5mm
<b>Phantom</b>	Validation plane
<b>Device Position</b>	Back
<b>Band</b>	GSM1900
<b>Channels</b>	512
<b>Signal</b>	GSM (Duty cycle: 1:8)

## B. SAR Measurement Results

<b>E-Field Probe</b>	SATIMO SN_04/13_EP166
<b>Frequency (MHz)</b>	1850.2
<b>Relative permittivity (real part)</b>	52.92
<b>Relative permittivity (imaginary part)</b>	14.21
<b>Conductivity (S/m)</b>	1.50
<b>Variation (%)</b>	-4.13
<b>ConvF:</b>	5.43

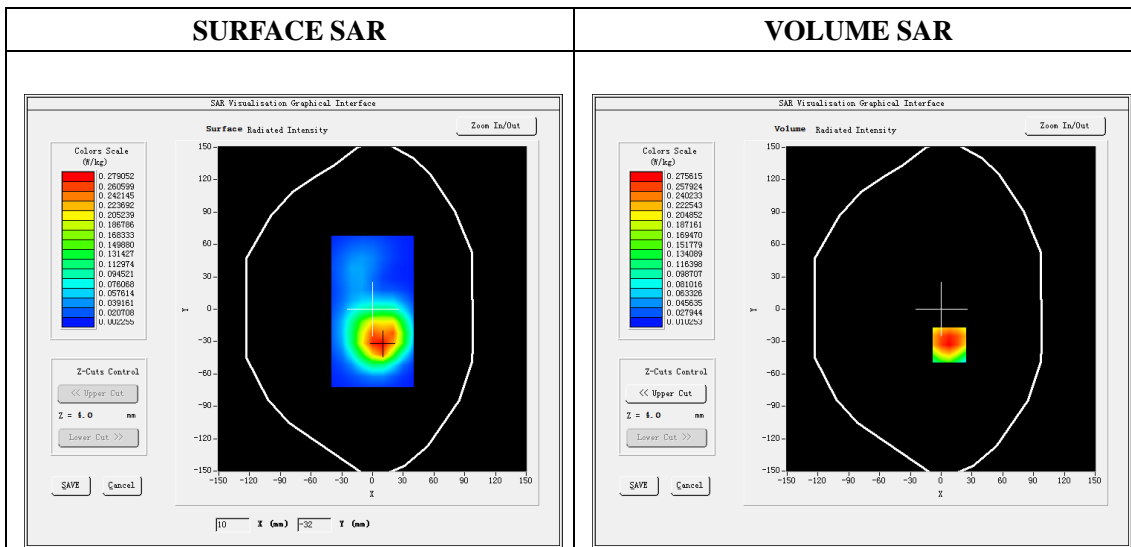

**Maximum location: X=8.00, Y=-33.00**

<b>SAR 10g (W/Kg)</b>	0.163343
<b>SAR 1g (W/Kg)</b>	0.263387

Z (mm)	0.00	4.00	9.00	14.00	19.00
SAR (W/Kg)	0.3693	0.2756	0.1861	0.1213	0.0752

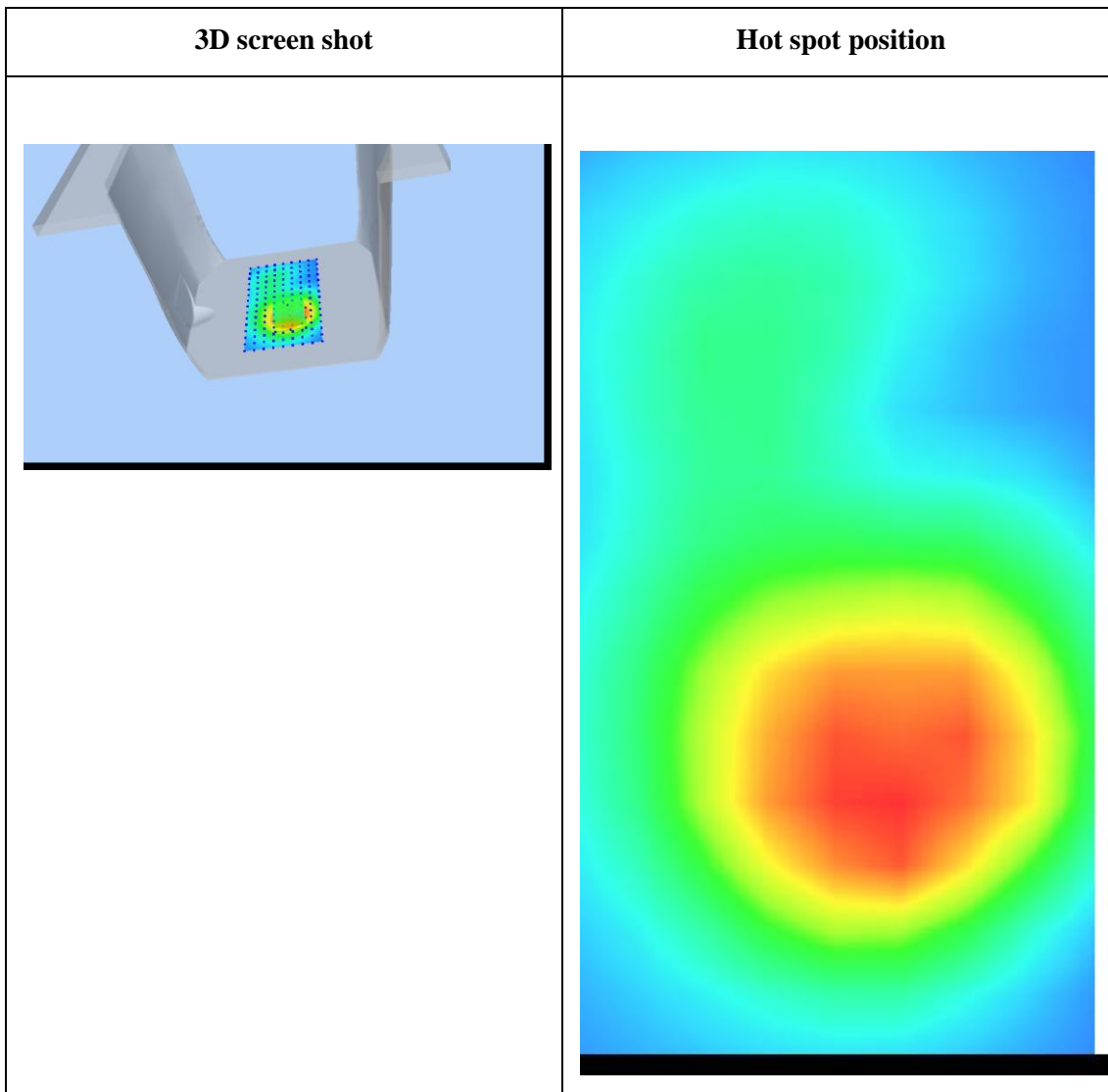
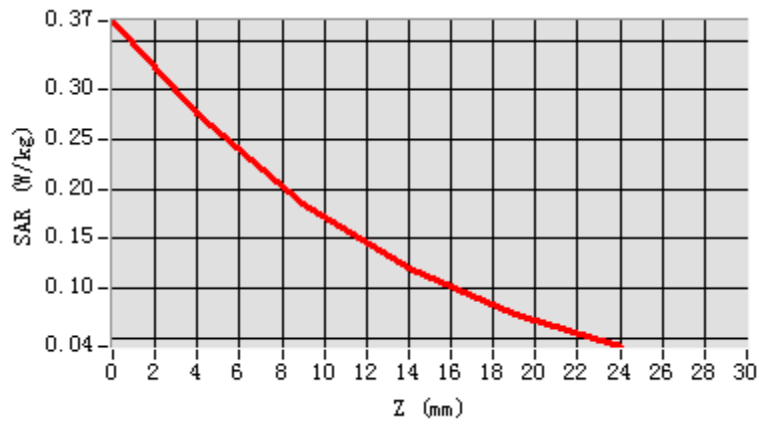



**ANNEX D**

**of**

**CCIC-SET**

**CONFORMANCE TEST REPORT FOR**

**HUMAN EXPOSURE TO ELECTROMAGNETIC FIELDS**

**SET2015-13711**

**Punkt.**

**Type Name: MP 01**

**Hardware Version: V1.2**

**Software Version: M60A\_A201\_082\_V26**

**Calibration Certificate of Probe and Dipoles**

**This Annex consists of 36 pages**

**Date of Report: 2015-09-25**

## Probe Calibration Certificate

**COMOSAR E-Field Probe Calibration Report**

Ref: ACR.227.15.14.SATU.A

**CCIC SOUTHERN ELECTRONIC PRODUCT  
TESTING (SHENZHEN) CO., LTD  
ELECTRONIC TESTING BUILDING, SHAHE ROAD, XILI  
TOWN  
SHENZHEN, P.R. CHINA (POST CODE:518055)  
SATIMO COMOSAR DOSIMETRIC E-FIELD PROBE  
SERIAL NO.: SN 04/13 EP166**

**Calibrated at SATIMO US  
2105 Barrett Park Dr. - Kennesaw, GA 30144**

**08/10/2015***Summary:*

This document presents the method and results from an accredited COMOSAR Dosimetric E-Field Probe calibration performed in SATIMO USA using the CALISAR / CALIBAIR test bench, for use with a SATIMO COMOSAR system only. All calibration results are traceable to national metrology institutions.



	<i>Name</i>	<i>Function</i>	<i>Date</i>	<i>Signature</i>
<i>Prepared by :</i>	Jérôme LUC	Product Manager	8/11/2015	<i>JS</i>
<i>Checked by :</i>	Jérôme LUC	Product Manager	8/11/2015	<i>JS</i>
<i>Approved by :</i>	Kim RUTKOWSKI	Quality Manager	8/11/2015	<i>Kim Rutkowski</i>

	<i>Customer Name</i>
<i>Distribution :</i>	CCIC SOUTHERN ELECTRONIC PRODUCT TESTING (SHENZHEN) Co., Ltd

<i>Issue</i>	<i>Date</i>	<i>Modifications</i>
<b>A</b>	8/11/2015	<b>Initial release</b>

*This document shall not be reproduced, except in full or in part, without the written approval of SATIMO.  
The information contained herein is to be used only for the purpose for which it is submitted and is not to be released in whole or part without written approval of SATIMO.*



**TABLE OF CONTENTS**

1 Device Under Test ..... 4

2 Product Description ..... 4

    2.1 General Information ..... 4

3 Measurement Method ..... 4

    3.1 Linearity ..... 4

    3.2 Sensitivity ..... 5

    3.3 Lower Detection Limit ..... 5

    3.4 Isotropy ..... 5

    3.5 Boundary Effect ..... 5

4 Measurement Uncertainty ..... 5

5 Calibration Measurement Results ..... 6

    5.1 Sensitivity in air ..... 6

    5.2 Linearity ..... 7

    5.3 Sensitivity in liquid ..... 7

    5.4 Isotropy ..... 8

6 List of Equipment ..... 9

*This document shall not be reproduced, except in full or in part, without the written approval of SATIMO.  
The information contained herein is to be used only for the purpose for which it is submitted and is not to be released in whole or part without written approval of SATIMO.*



## 1 DEVICE UNDER TEST

Device Under Test	
Device Type	COMOSAR DOSIMETRIC E FIELD PROBE
Manufacturer	Satimo
Model	SSE5
Serial Number	SN 04/13 EP166
Product Condition (new / used)	Used
Frequency Range of Probe	0.7 GHz-3 GHz
Resistance of Three Dipoles at Connector	Dipole 1: R1=0.231 MΩ Dipole 2: R2=0.225 MΩ Dipole 3: R3=0.228 MΩ

A yearly calibration interval is recommended.

## 2 PRODUCT DESCRIPTION

### 2.1 GENERAL INFORMATION

Satimo's COMOSAR E field Probes are built in accordance to the IEEE 1528, OET 65 Bulletin C and CEI/IEC 62209 standards.



**Figure 1** – Satimo COMOSAR Dosimetric E field Dipole

Probe Length	330 mm
Length of Individual Dipoles	4.5 mm
Maximum external diameter	8 mm
Probe Tip External Diameter	5 mm
Distance between dipoles / probe extremity	2.7 mm

## 3 MEASUREMENT METHOD

The IEEE 1528, OET 65 Bulletin C, CENELEC EN50361 and CEI/IEC 62209 standards provide recommended practices for the probe calibrations, including the performance characteristics of interest and methods by which to assess their affect. All calibrations / measurements performed meet the fore mentioned standards.

### 3.1 LINEARITY

The evaluation of the linearity was done in free space using the waveguide, performing a power sweep to cover the SAR range 0.01W/kg to 100W/kg.

Page: 4/9

*This document shall not be reproduced, except in full or in part, without the written approval of SATIMO.  
The information contained herein is to be used only for the purpose for which it is submitted and is not to be released in whole or part without written approval of SATIMO.*

### 3.2 SENSITIVITY

The sensitivity factors of the three dipoles were determined using a two step calibration method (air and tissue simulating liquid) using waveguides as outlined in the standards.

### 3.3 LOWER DETECTION LIMIT

The lower detection limit was assessed using the same measurement set up as used for the linearity measurement. The required lower detection limit is 10 mW/kg.

### 3.4 ISOTROPY

The axial isotropy was evaluated by exposing the probe to a reference wave from a standard dipole with the dipole mounted under the flat phantom in the test configuration suggested for system validations and checks. The probe was rotated along its main axis from 0 - 360 degrees in 15 degree steps. The hemispherical isotropy is determined by inserting the probe in a thin plastic box filled with tissue-equivalent liquid, with the plastic box illuminated with the fields from a half wave dipole. The dipole is rotated about its axis (0°–180°) in 15° increments. At each step the probe is rotated about its axis (0°–360°).

### 3.5 BOUNDARY EFFECT

The boundary effect is defined as the deviation between the SAR measured data and the expected exponential decay in the liquid when the probe is oriented normal to the interface. To evaluate this effect, the liquid filled flat phantom is exposed to fields from either a reference dipole or waveguide. With the probe normal to the phantom surface, the peak spatial average SAR is measured and compared to the analytical value at the surface.

## 4 MEASUREMENT UNCERTAINTY

The guidelines outlined in the IEEE 1528, OET 65 Bulletin C, CENELEC EN50361 and CEI/IEC 62209 standards were followed to generate the measurement uncertainty associated with an E-field probe calibration using the waveguide technique. All uncertainties listed below represent an expanded uncertainty expressed at approximately the 95% confidence level using a coverage factor of  $k=2$ , traceable to the Internationally Accepted Guides to Measurement Uncertainty.

Uncertainty analysis of the probe calibration in waveguide					
ERROR SOURCES	Uncertainty value (%)	Probability Distribution	Divisor	ci	Standard Uncertainty (%)
Incident or forward power	3.00%	Rectangular	$\sqrt{3}$	1	1.732%
Reflected power	3.00%	Rectangular	$\sqrt{3}$	1	1.732%
Liquid conductivity	5.00%	Rectangular	$\sqrt{3}$	1	2.887%
Liquid permittivity	4.00%	Rectangular	$\sqrt{3}$	1	2.309%
Field homogeneity	3.00%	Rectangular	$\sqrt{3}$	1	1.732%
Field probe positioning	5.00%	Rectangular	$\sqrt{3}$	1	2.887%
Field probe linearity	3.00%	Rectangular	$\sqrt{3}$	1	1.732%

Page: 5/9

*This document shall not be reproduced, except in full or in part, without the written approval of SATIMO.  
The information contained herein is to be used only for the purpose for which it is submitted and is not to be released in whole or part without written approval of SATIMO.*

Combined standard uncertainty					5.831%
Expanded uncertainty 95 % confidence level k = 2					12.0%

## 5 CALIBRATION MEASUREMENT RESULTS

Calibration Parameters	
Liquid Temperature	21 °C
Lab Temperature	21 °C
Lab Humidity	45 %

### 5.1 SENSITIVITY IN AIR

Normx dipole 1 ( $\mu\text{V}/(\text{V}/\text{m})^2$ )	Normy dipole 2 ( $\mu\text{V}/(\text{V}/\text{m})^2$ )	Normz dipole 3 ( $\mu\text{V}/(\text{V}/\text{m})^2$ )
8.57	4.83	7.15

DCP dipole 1 (mV)	DCP dipole 2 (mV)	DCP dipole 3 (mV)
92	90	95

Calibration curves  $e_i=f(V)$  ( $i=1,2,3$ ) allow to obtain H-field value using the formula:

$$E = \sqrt{E_1^2 + E_2^2 + E_3^2}$$

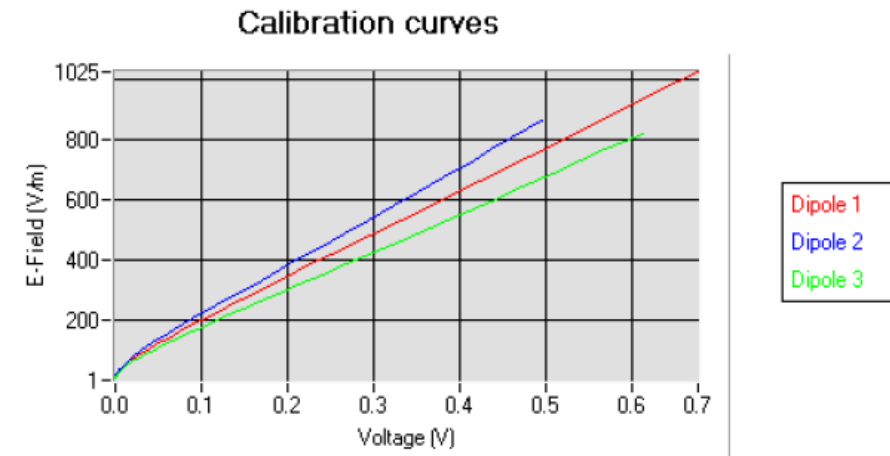

Page: 6/9

*This document shall not be reproduced, except in full or in part, without the written approval of SATIMO. The information contained herein is to be used only for the purpose for which it is submitted and is not to be released in whole or part without written approval of SATIMO.*

## 5.2 LINEARITY

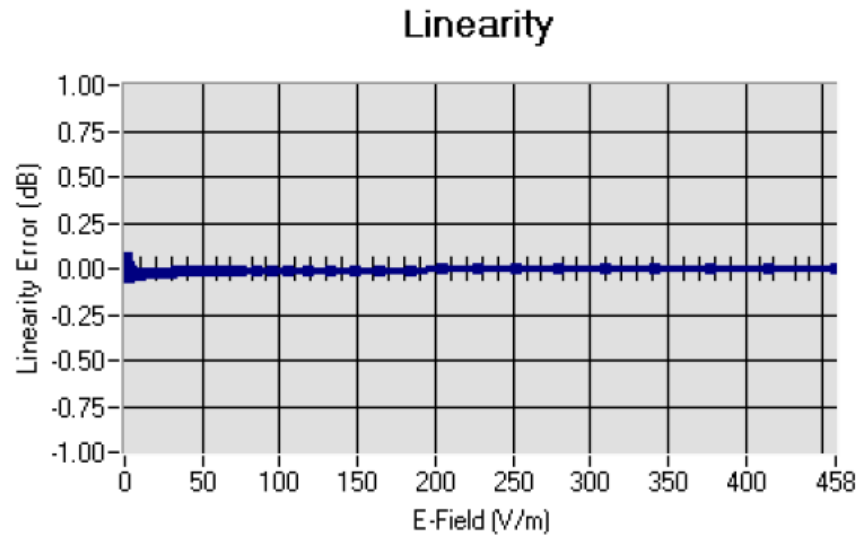

Linearity:  $\pm 1.55\%$  ( $\pm 0.07\text{dB}$ )

## 5.3 SENSITIVITY IN LIQUID

Liquid	Frequency (MHz +/- 100MHz)	Permittivity	Epsilon (S/m)	ConvF
HL850	835	42.80	0.89	5.69
BL850	835	53.45	0.96	5.82
HL900	900	42.47	0.96	5.34
BL900	900	56.68	1.08	5.55
HL1800	1800	41.30	1.38	4.75
BL1800	1800	53.27	1.51	4.96
HL1900	1900	41.09	1.42	5.25
BL1900	1900	54.20	1.54	5.43
HL2000	2000	39.72	1.43	4.81
BL2000	2000	53.90	1.53	4.95
HL2450	2450	39.05	1.77	4.93
BL2450	2450	52.98	1.93	5.09
HL2600	2600	38.35	1.92	5.08
BL2600	2600	51.82	2.19	5.22

LOWER DETECTION LIMIT: 7mW/kg

Page: 7/9

*This document shall not be reproduced, except in full or in part, without the written approval of SATIMO. The information contained herein is to be used only for the purpose for which it is submitted and is not to be released in whole or part without written approval of SATIMO.*

#### 5.4 ISOTROPY

##### HL900 MHz

- Axial isotropy: 0.04 dB
- Hemispherical isotropy: 0.07 dB

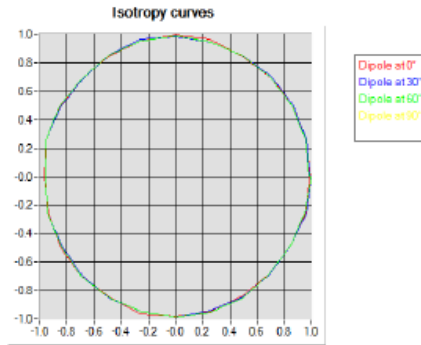

##### HL1800 MHz

- Axial isotropy: 0.05 dB
- Hemispherical isotropy: 0.07 dB

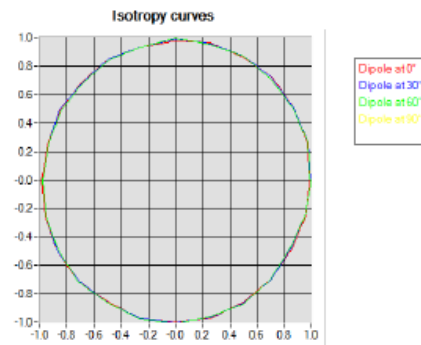

Page: 8/9

*This document shall not be reproduced, except in full or in part, without the written approval of SATIMO. The information contained herein is to be used only for the purpose for which it is submitted and is not to be released in whole or part without written approval of SATIMO.*

**6 LIST OF EQUIPMENT**

Equipment Summary Sheet				
Equipment Description	Manufacturer / Model	Identification No.	Current Calibration Date	Next Calibration Date
Flat Phantom	Satimo	SN-20/09-SAM71	Validated. No cal required.	Validated. No cal required.
COMOSAR Test Bench	Version 3	NA	Validated. No cal required.	Validated. No cal required.
Network Analyzer	Rhode & Schwarz ZVA	SN100132	02/2013	02/2016
Reference Probe	Satimo	EP 94 SN 37/08	10/2014	10/2015
Multimeter	Keithley 2000	1188656	12/2013	12/2016
Signal Generator	Agilent E4438C	MY49070581	12/2013	12/2016
Amplifier	Aethercomm	SN 046	Characterized prior to test. No cal required.	Characterized prior to test. No cal required.
Power Meter	HP E4418A	US38261498	12/2013	12/2016
Power Sensor	HP ECP-E26A	US37181460	12/2013	12/2016
Directional Coupler	Narda 4216-20	01386	Characterized prior to test. No cal required.	Characterized prior to test. No cal required.
Waveguide	Mega Industries	069Y7-158-13-712	Validated. No cal required.	Validated. No cal required.
Waveguide Transition	Mega Industries	069Y7-158-13-701	Validated. No cal required.	Validated. No cal required.
Waveguide Termination	Mega Industries	069Y7-158-13-701	Validated. No cal required.	Validated. No cal required.
Temperature / Humidity Sensor	Control Company	11-661-9	8/2013	8/2016

Page: 9/9

*This document shall not be reproduced, except in full or in part, without the written approval of SATIMO. The information contained herein is to be used only for the purpose for which it is submitted and is not to be released in whole or part without written approval of SATIMO.*

**SID835 Dipole Calibration Certificate****SAR Reference Dipole Calibration Report**

Ref: ACR.240.1.14.SATU.A

**CCIC SOUTHERN ELECTRONIC PRODUCT  
TESTING (SHENZHEN) CO., LTD  
ELECTRONIC TESTING BUILDING, SHAHE ROAD, XILI  
TOWN  
SHENZHEN, P.R. CHINA (POST CODE:518055)  
SATIMO COMOSAR REFERENCE DIPOLE  
FREQUENCY: 835 MHZ  
SERIAL NO.: SN 09/13 DIP0G835-217**

**Calibrated at SATIMO US  
2105 Barrett Park Dr. - Kennesaw, GA 30144**



08/28/14

*Summary:*

This document presents the method and results from an accredited SAR reference dipole calibration performed in SATIMO USA using the COMOSAR test bench. All calibration results are traceable to national metrology institutions.



SAR REFERENCE DIPOLE CALIBRATION REPORT

Ref: ACR.240.1.14.SATU.A

	<i>Name</i>	<i>Function</i>	<i>Date</i>	<i>Signature</i>
<i>Prepared by :</i>	Jérôme LUC	Product Manager	8/29/2014	
<i>Checked by :</i>	Jérôme LUC	Product Manager	8/29/2014	
<i>Approved by :</i>	Kim RUTKOWSKI	Quality Manager	8/29/2014	

<i>Distribution :</i>	<i>Customer Name</i> CCIC SOUTHERN ELECTRONIC PRODUCT TESTING (SHENZHEN) Co., Ltd
-----------------------	---

<i>Issue</i>	<i>Date</i>	<i>Modifications</i>
A	8/29/2014	Initial release





## TABLE OF CONTENTS

1	Introduction.....	4
2	Device Under Test .....	4
3	Product Description .....	4
3.1	General Information .....	4
4	Measurement Method .....	5
4.1	Return Loss Requirements .....	5
4.2	Mechanical Requirements .....	5
5	Measurement Uncertainty .....	5
5.1	Return Loss .....	5
5.2	Dimension Measurement .....	5
5.3	Validation Measurement .....	5
6	Calibration Measurement Results.....	6
6.1	Return Loss and Impedance In Head Liquid .....	6
6.2	Return Loss and Impedance In Body Liquid .....	6
6.3	Mechanical Dimensions .....	6
7	Validation measurement .....	7
7.1	Head Liquid Measurement .....	7
7.2	SAR Measurement Result With Head Liquid .....	8
7.3	Body Liquid Measurement .....	9
7.4	SAR Measurement Result With Body Liquid .....	10
8	List of Equipment .....	11

Page: 3/11

*This document shall not be reproduced, except in full or in part, without the written approval of SATIMO.*

## 1 INTRODUCTION

This document contains a summary of the requirements set forth by the IEEE 1528, OET 65 Bulletin C and CEI/IEC 62209 standards for reference dipoles used for SAR measurement system validations and the measurements that were performed to verify that the product complies with the fore mentioned standards.

## 2 DEVICE UNDER TEST

Device Under Test	
Device Type	COMOSAR 835 MHz REFERENCE DIPOLE
Manufacturer	Satimo
Model	SID835
Serial Number	SN 09/13 DIP0G835-217
Product Condition (new / used)	used

A yearly calibration interval is recommended.

## 3 PRODUCT DESCRIPTION

### 3.1 GENERAL INFORMATION

Satimo's COMOSAR Validation Dipoles are built in accordance to the IEEE 1528, OET 65 Bulletin C and CEI/IEC 62209 standards. The product is designed for use with the COMOSAR test bench only.



Figure 1 – Satimo COMOSAR Validation Dipole



**4 MEASUREMENT METHOD**

The IEEE 1528, OET 65 Bulletin C and CEI/IEC 62209 standards provide requirements for reference dipoles used for system validation measurements. The following measurements were performed to verify that the product complies with the fore mentioned standards.

**4.1 RETURN LOSS REQUIREMENTS**

The dipole used for SAR system validation measurements and checks must have a return loss of -20 dB or better. The return loss measurement shall be performed against a liquid filled flat phantom, with the phantom constructed as outlined in the fore mentioned standards.

**4.2 MECHANICAL REQUIREMENTS**

The IEEE Std. 1528 and CEI/IEC 62209 standards specify the mechanical components and dimensions of the validation dipoles, with the dimensions frequency and phantom shell thickness dependent. The COMOSAR test bench employs a 2 mm phantom shell thickness therefore the dipoles sold for use with the COMOSAR test bench comply with the requirements set forth for a 2 mm phantom shell thickness.

**5 MEASUREMENT UNCERTAINTY**

All uncertainties listed below represent an expanded uncertainty expressed at approximately the 95% confidence level using a coverage factor of  $k=2$ , traceable to the Internationally Accepted Guides to Measurement Uncertainty.

**5.1 RETURN LOSS**

The following uncertainties apply to the return loss measurement:

Frequency band	Expanded Uncertainty on Return Loss
400-6000MHz	0.1 dB

**5.2 DIMENSION MEASUREMENT**

The following uncertainties apply to the dimension measurements:

Length (mm)	Expanded Uncertainty on Length
3 - 300	0.05 mm

**5.3 VALIDATION MEASUREMENT**

The guidelines outlined in the IEEE 1528, OET 65 Bulletin C, CFNELEC EN50361 and CEI/IEC 62209 standards were followed to generate the measurement uncertainty for validation measurements.

Scan Volume	Expanded Uncertainty
1 g	20.3 %
10 g	20.1 %



**6 CALIBRATION MEASUREMENT RESULTS**

**6.1 RETURN LOSS AND IMPEDANCE IN HEAD LIQUID**

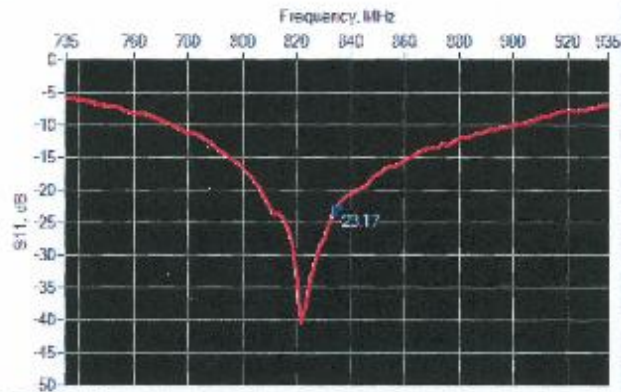

Frequency (MHz)	Return Loss (dB)	Requirement (dB)	Impedance
835	-23.17	-20	57.4 Ω - 0.2 jΩ

**6.2 RETURN LOSS AND IMPEDANCE IN BODY LIQUID**

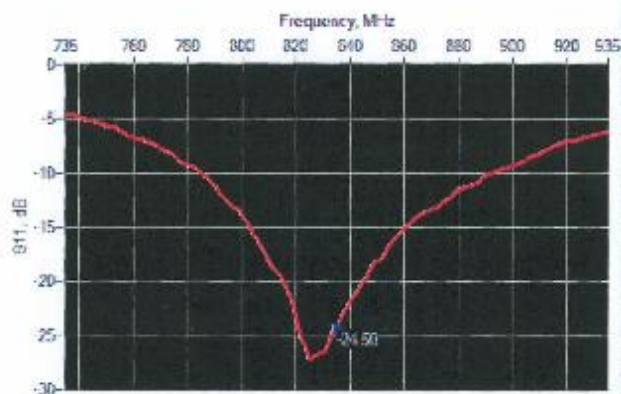

Frequency (MHz)	Return Loss (dB)	Requirement (dB)	Impedance
835	-24.50	-20	55.0 Ω + 3.9 jΩ

**6.3 MECHANICAL DIMENSIONS**

Frequency MHz	L mm		h mm		d mm	
	required	measured	required	measured	required	measured
300	420.0 ±1 %		250.0 ±1 %		6.35 ±1 %	
450	290.0 ±1 %		256.7 ±1 %		6.35 ±1 %	
750	176.0 ±1 %		200.0 ±1 %		6.35 ±1 %	
835	161.0 ±1 %	PASS	89.8 ±1 %	PASS	3.6 ±1 %	PASS

Page: 6/11

*This document shall not be reproduced, stored in full or in part, without the written approval of SATIMO.*



## SAR REFERENCE DIPOLE CALIBRATION REPORT

Ref: ACR.240.L14.SATICA

900	149.0 ±1 %		89.3 ±1 %		3.6 ±1 %
1450	89.1 ±1 %		51.7 ±1 %		3.6 ±1 %
1500	80.5 ±1 %		50.0 ±1 %		3.6 ±1 %
1640	79.0 ±1 %		45.7 ±1 %		3.6 ±1 %
1750	75.2 ±1 %		42.9 ±1 %		3.6 ±1 %
1800	72.0 ±1 %		41.7 ±1 %		3.6 ±1 %
1900	68.0 ±1 %		39.5 ±1 %		3.6 ±1 %
1950	66.3 ±1 %		38.5 ±1 %		3.6 ±1 %
2000	64.5 ±1 %		37.5 ±1 %		3.6 ±1 %
2100	61.0 ±1 %		35.7 ±1 %		3.6 ±1 %
2300	55.5 ±1 %		32.6 ±1 %		3.6 ±1 %
2450	51.5 ±1 %		30.4 ±1 %		3.6 ±1 %
2600	48.5 ±1 %		28.8 ±1 %		3.6 ±1 %
3000	41.5 ±1 %		25.0 ±1 %		3.6 ±1 %
3500	37.0 ±1 %		26.4 ±1 %		3.6 ±1 %
3700	34.7 ±1 %		26.4 ±1 %		3.6 ±1 %

## 7 VALIDATION MEASUREMENT

The IEEE Std. 1528, OET 65 Bulletin C and CEI/IEC 62209 standards state that the system validation measurements must be performed using a reference dipole meeting the fore mentioned return loss and mechanical dimension requirements. The validation measurement must be performed against a liquid filled flat phantom, with the phantom constructed as outlined in the fore mentioned standards. Per the standards, the dipole shall be positioned below the bottom of the phantom, with the dipole length centered and parallel to the longest dimension of the flat phantom, with the top surface of the dipole at the described distance from the bottom surface of the phantom.

### 7.1 HEAD LIQUID MEASUREMENT

Frequency MHz	Relative permittivity ( $\epsilon_r$ )		Conductivity ( $\sigma$ ) S/m	
	required	measured	required	measured
300	45.3 ±5 %		0.87 ±5 %	
450	43.5 ±5 %		0.87 ±5 %	
750	41.9 ±5 %		0.89 ±5 %	
835	41.5 ±5 %	PASS	0.90 ±5 %	PASS
900	41.5 ±5 %		0.97 ±5 %	
1450	40.5 ±5 %		1.20 ±5 %	
1500	40.4 ±5 %		1.23 ±5 %	
1640	40.2 ±5 %		1.31 ±5 %	
1750	40.1 ±5 %		1.37 ±5 %	
1800	40.0 ±5 %		1.40 ±5 %	
1900	40.0 ±5 %		1.40 ±5 %	
1950	40.0 ±5 %		1.40 ±5 %	
2000	40.0 ±5 %		1.40 ±5 %	

Page: 7/11

*This document shall not be reproduced, except in full or in part, without the written approval of SATIMO.*



SAR REFERENCE DIPOLE CALIBRATION REPORT

Ref: ACR.240.14.SATU.A

2100	39.8 ±5 %		1.49 ±5 %	
2300	39.5 ±5 %		1.67 ±5 %	
2450	39.2 ±5 %		1.80 ±5 %	
2600	39.0 ±5 %		1.96 ±5 %	
3000	38.5 ±5 %		2.40 ±5 %	
3500	37.9 ±5 %		2.91 ±5 %	

7.2 SAR MEASUREMENT RESULT WITH HEAD LIQUID

The IEEE Std. 1528 and CEI/IEC 62209 standards state that the system validation measurements should produce the SAR values shown below (for phantom thickness of 2 mm), within the uncertainty for the system validation. All SAR values are normalized to 1 W forward power. In bracket, the measured SAR is given with the used input power.

Software	OPENSAR V4
Phantom	SN 20/09 SAM71
Probe	SN 18/11 EPG122
Liquid	Head Liquid Values: eps' : 42.3 sigma : 0.92
Distance between dipole center and liquid	15.0 mm
Area scan resolution	dx=8mm/dy=8mm
Zoon Scan Resolution	dx=8mm/dy=8mm/dz=5mm
Frequency	835 MHz
Input power	20 dBm
Liquid Temperature	21 °C
Lab Temperature	21 °C
Lab Humidity	45 %

Frequency MHz	1 g SAR (W/kg/W)		10 g SAR (W/kg/W)	
	required	measured	required	measured
300	2.85		1.94	
450	4.58		3.06	
750	8.49		5.55	
835	9.56	9.77 (0.98)	6.22	6.30 (0.63)
900	10.9		6.99	
1450	29		16	
1500	30.5		16.8	
1640	34.2		18.4	
1750	36.4		19.3	
1800	38.4		20.1	
1900	39.7		20.5	
1950	40.5		20.9	
2000	41.1		21.1	
2100	43.6		21.9	
2300	48.7		23.3	

Page: 8/11

*This document shall not be reproduced, except in full or in part, without the written approval of SATIMO.*



## SAR REFERENCE DIPOLE CALIBRATION REPORT

Ref: ACR.240.1.14.SAT1.A

2450	52.4		24
2600	55.3		24.6
3000	63.8		25.7
3500	67.1		25

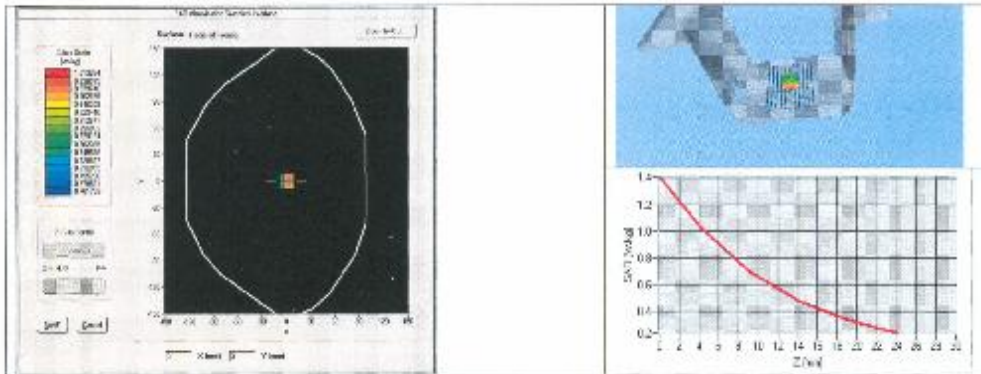

## 7.3 BODY LIQUID MEASUREMENT

Frequency MHz	Relative permittivity ( $\epsilon_r$ )		Conductivity ( $\sigma$ ) S/m	
	required	measured	required	measured
150	61.9 $\pm$ 5 %		0.80 $\pm$ 5 %	
300	58.2 $\pm$ 5 %		0.92 $\pm$ 5 %	
450	56.7 $\pm$ 5 %		0.94 $\pm$ 5 %	
750	55.5 $\pm$ 5 %		0.96 $\pm$ 5 %	
835	55.2 $\pm$ 5 %	PASS	0.97 $\pm$ 5 %	PASS
900	55.0 $\pm$ 5 %		1.05 $\pm$ 5 %	
915	55.0 $\pm$ 5 %		1.06 $\pm$ 5 %	
1450	54.0 $\pm$ 5 %		1.30 $\pm$ 5 %	
1610	53.8 $\pm$ 5 %		1.40 $\pm$ 5 %	
1800	53.3 $\pm$ 5 %		1.52 $\pm$ 5 %	
1900	53.3 $\pm$ 5 %		1.52 $\pm$ 5 %	
2000	53.3 $\pm$ 5 %		1.52 $\pm$ 5 %	
2100	53.2 $\pm$ 5 %		1.62 $\pm$ 5 %	
2450	52.7 $\pm$ 5 %		1.95 $\pm$ 5 %	
2600	52.5 $\pm$ 5 %		2.16 $\pm$ 5 %	
3000	52.0 $\pm$ 5 %		2.73 $\pm$ 5 %	
3500	51.3 $\pm$ 5 %		3.31 $\pm$ 5 %	
5200	49.0 $\pm$ 10 %		5.30 $\pm$ 10 %	
5300	48.9 $\pm$ 10 %		5.42 $\pm$ 10 %	
5400	48.7 $\pm$ 10 %		5.53 $\pm$ 10 %	

Page: 9/11

This document shall not be reproduced, except in full or in part, without the written approval of SATIMO.



SAR REFERENCE DIPOLE CALIBRATION REPORT

Ref. ACR 340.1.14.SATU.A

5500	48.5 ±10 %		5.65 ±10 %	
5600	48.5 ±10 %		5.77 ±10 %	
5800	48.2 ±10 %		6.00 ±10 %	

7.4 SAR MEASUREMENT RESULT WITH BODY LIQUID

Software	OPENSAR V4
Phantom	SN 20:09 SAM71
Probe	SN 18:1 EPG122
Liquid	Body Liquid Values: eps' : 54.1 sigma : 0.97
Distance between dipole center and liquid	15.0 mm
Area scan resolution	dx=8mm/dy=8mm
Zoon Scan Resolution	dx=8mm/dy=8m/dz=5mm
Frequency	815 MHz
Input power	20 dBm
Liquid Temperature	21 °C
Lab Temperature	21 °C
Lab Humidity	45 %

Frequency MHz	1 g SAR (W/kg/W)	10 g SAR (W/kg/W)
	measured	measured
835	10.31 (1.03)	6.74 (0.67)

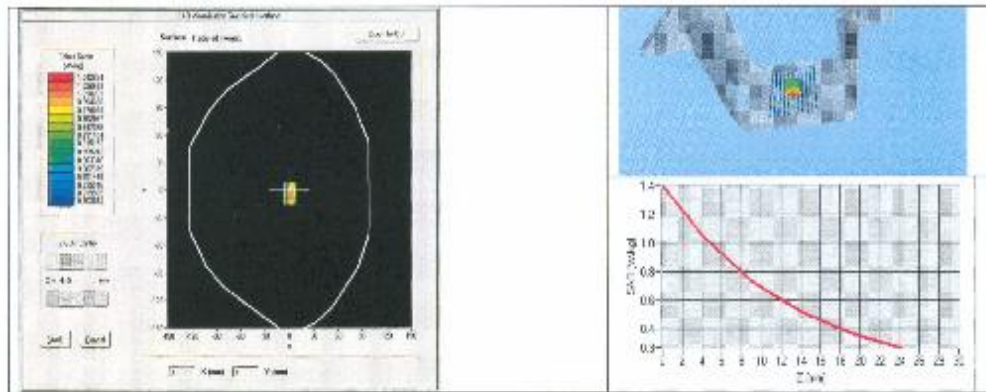





8 LIST OF EQUIPMENT

Equipment Summary Sheet				
Equipment Description	Manufacturer / Model	Identification No.	Current Calibration Date	Next Calibration Date
SAM Phantom	Satimo	SN-20/09-SAM71	Validated. No cal required.	Validated. No cal required.
COMOSAR Test Bench	Version 3	NA	Validated. No cal required.	Validated. No cal required.
Network Analyzer	Rhode & Schwarz ZVA	SN100132	02/2013	02/2016
Calipers	Carrera	CALIPER-01	12/2013	12/2016
Reference Probe	Satimo	EPG122 SN 18/11	10/2013	10/2014
Multimeter	Keithley 2000	1188656	12/2013	12/2016
Signal Generator	Agilent E4438C	MY49070581	12/2013	12/2016
Amplifier	Aethercomm	SN 046	Characterized prior to test. No cal required.	Characterized prior to test. No cal required.
Power Meter	HP E4418A	US38261498	12/2013	12/2016
Power Sensor	HP ECP-E26A	US37181460	12/2013	12/2016
Directional Coupler	Narda 4216-20	01386	Characterized prior to test. No cal required.	Characterized prior to test. No cal required.
Temperature and Humidity Sensor	Control Company	11-861-9	8/2012	8/2015

**SID1900 Dipole Calibration Certificate****SAR Reference Dipole Calibration Report**

Ref : ACR.240.4.14.SATU.A

**CCIC SOUTHERN ELECTRONIC PRODUCT  
TESTING (SHENZHEN) CO., LTD  
ELECTRONIC TESTING BUILDING, SHAHE ROAD, XILI  
TOWN  
SHENZHEN, P.R. CHINA (POST CODE:518055)  
SATIMO COMOSAR REFERENCE DIPOLE  
FREQUENCY: 1900 MHZ  
SERIAL NO.: SN 09/13 DIPIG900-218**

**Calibrated at SATIMO US  
2105 Barrett Park Dr. - Kennesaw, GA 30144**



08/28/14

*Summary:*

This document presents the method and results from an accredited SAR reference dipole calibration performed in SATIMO USA using the COMOSAR test bench. All calibration results are traceable to national metrology institutions.



SAR REFERENCE DIPOLE CALIBRATION REPORT

Ref: ACR240414.SAT0.A

	<i>Name</i>	<i>Function</i>	<i>Date</i>	<i>Signature</i>
<i>Prepared by :</i>	Jérôme LUC	Product Manager	8/29/2014	<i>JL</i>
<i>Checked by :</i>	Jérôme LUC	Product Manager	8/29/2014	<i>JL</i>
<i>Approved by :</i>	Kim RUTKOWSKI	Quality Manager	8/29/2014	<i>Kim Rutkowski</i>

	<i>Customer Name</i>
<i>Distribution :</i>	CCIC SOUTHERN ELECTRONIC PRODUCT TESTING (SHENZHEN) Co., Ltd

<i>Issue</i>	<i>Date</i>	<i>Modifications</i>
A	8/29/2014	Initial release



TABLE OF CONTENTS

1 Introduction..... 4

2 Device Under Test ..... 4

3 Product Description ..... 4

    3.1 General Information ..... 4

4 Measurement Method ..... 5

    4.1 Return Loss Requirements ..... 5

    4.2 Mechanical Requirements ..... 5

5 Measurement Uncertainty ..... 5

    5.1 Return Loss ..... 5

    5.2 Dimension Measurement ..... 5

    5.3 Validation Measurement ..... 5

6 Calibration Measurement Results..... 6

    6.1 Return Loss and Impedance In Head Liquid ..... 6

    6.2 Return Loss and Impedance In Body Liquid ..... 6

    6.3 Mechanical Dimensions ..... 6

7 Validation measurement ..... 7

    7.1 Head Liquid Measurement ..... 7

    7.2 SAR Measurement Result With Head Liquid ..... 8

    7.3 Body Liquid Measurement ..... 9

    7.4 SAR Measurement Result With Body Liquid ..... 10

8 List of Equipment ..... 11



**1 INTRODUCTION**

This document contains a summary of the requirements set forth by the IEEE 1528, OET 65 Bulletin C and CEI/IEC 62209 standards for reference dipoles used for SAR measurement system validations and the measurements that were performed to verify that the product complies with the fore mentioned standards.

**2 DEVICE UNDER TEST**

Device Under Test	
Device Type	COMOSAR 1900 MHz REFERENCE DIPOLE
Manufacturer	Satimo
Model	SID1900
Serial Number	SN 09/13 DIP1G900-218
Product Condition (new / used)	Used

A yearly calibration interval is recommended.

**3 PRODUCT DESCRIPTION**

**3.1 GENERAL INFORMATION**

Satimo’s COMOSAR Validation Dipoles are built in accordance to the IEEE 1528, OET 65 Bulletin C and CEI/IEC 62209 standards. The product is designed for use with the COMOSAR test bench only.



Figure 1 – Satimo COMOSAR Validation Dipole



**4 MEASUREMENT METHOD**

The IEEE 1528, OET 65 Bulletin C and CEI/IEC 62209 standards provide requirements for reference dipoles used for system validation measurements. The following measurements were performed to verify that the product complies with the fore mentioned standards.

**4.1 RETURN LOSS REQUIREMENTS**

The dipole used for SAR system validation measurements and checks must have a return loss of -20 dB or better. The return loss measurement shall be performed against a liquid filled flat phantom, with the phantom constructed as outlined in the fore mentioned standards.

**4.2 MECHANICAL REQUIREMENTS**

The IEEE Std. 1528 and CEI/IEC 62209 standards specify the mechanical components and dimensions of the validation dipoles, with the dimensions frequency and phantom shell thickness dependent. The COMOSAR test bench employs a 2 mm phantom shell thickness therefore the dipoles sold for use with the COMOSAR test bench comply with the requirements set forth for a 2 mm phantom shell thickness.

**5 MEASUREMENT UNCERTAINTY**

All uncertainties listed below represent an expanded uncertainty expressed at approximately the 95% confidence level using a coverage factor of k = 2, traceable to the Internationally Accepted Guides to Measurement Uncertainty.

**5.1 RETURN LOSS**

The following uncertainties apply to the return loss measurement:

Frequency band	Expanded Uncertainty on Return Loss
400-6000MHz	0.1 dB

**5.2 DIMENSION MEASUREMENT**

The following uncertainties apply to the dimension measurements:

Length (mm)	Expanded Uncertainty on Length
3 - 300	0.05 mm

**5.3 VALIDATION MEASUREMENT**

The guidelines outlined in the IEEE 1528, OET 65 Bulletin C, CEN/IEC EN50361 and CEI/IEC 62209 standards were followed to generate the measurement uncertainty for validation measurements.

Scan Volume	Expanded Uncertainty
1 g	20.3 %
10 g	20.1 %

Page: 5/11

*This document shall not be reproduced, copied in full or in part, without the written approval of SATIMO. The information contained herein is to be used only for the purpose for which it is submitted and not to be released in whole or part without written approval of SATIMO.*



## 6 CALIBRATION MEASUREMENT RESULTS

### 6.1 RETURN LOSS AND IMPEDANCE IN HEAD LIQUID

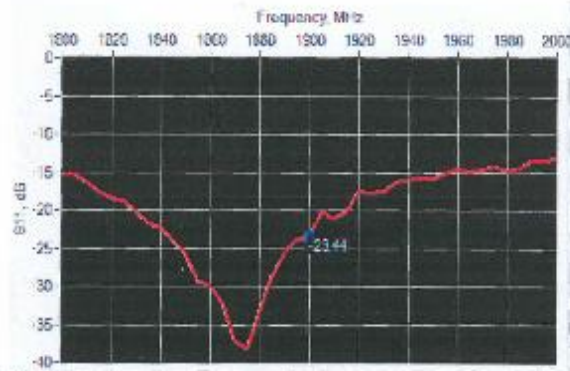

Frequency (MHz)	Return Loss (dB)	Requirement (dB)	Impedance
1900	-23.44	-20	$55.4 \Omega + 5.2 j\Omega$

### 6.2 RETURN LOSS AND IMPEDANCE IN BODY LIQUID

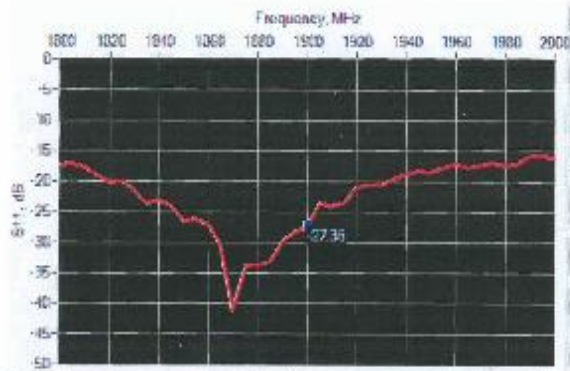

Frequency (MHz)	Return Loss (dB)	Requirement (dB)	Impedance
1900	-27.36	-20	$51.7 \Omega + 4.4 j\Omega$

### 6.3 MECHANICAL DIMENSIONS

Frequency MHz	L mm		h mm		d mm	
	required	measured	required	measured	required	measured
300	420.0 ±1 %		250.0 ±1 %		6.35 ±1 %	
450	290.0 ±1 %		166.7 ±1 %		6.35 ±1 %	
750	176.0 ±1 %		100.0 ±1 %		6.35 ±1 %	
835	161.0 ±1 %		89.8 ±1 %		3.5 ±1 %	

Page: 6/11

*This document shall not be reproduced, stored in full or in part, without the written approval of SATIMO. The registrant's continued license is to its used only for the purpose for which it is submitted and is not to be released in whole or part without written approval of SATIMO.*



SAR REFERENCE DIPOLE CALIBRATION REPORT

Ref: ACR.2015.15 SATIMA

900	149.0 ±1 %		83.3 ±1 %		3.6 ±1 %	
1450	89.1 ±1 %		51.7 ±1 %		3.6 ±1 %	
1500	80.5 ±1 %		50.0 ±1 %		3.6 ±1 %	
1640	79.0 ±1 %		45.7 ±1 %		3.6 ±1 %	
1750	75.2 ±1 %		42.9 ±1 %		3.6 ±1 %	
1800	72.0 ±1 %		41.7 ±1 %		3.6 ±1 %	
1900	68.0 ±1 %	PASS	39.5 ±1 %	PASS	3.6 ±1 %	PASS
1950	66.3 ±1 %		38.5 ±1 %		3.6 ±1 %	
2000	64.5 ±1 %		37.5 ±1 %		3.6 ±1 %	
2100	61.0 ±1 %		35.7 ±1 %		3.6 ±1 %	
2300	55.5 ±1 %		32.6 ±1 %		3.6 ±1 %	
2450	51.5 ±1 %		31.4 ±1 %		3.6 ±1 %	
2600	48.5 ±1 %		28.8 ±1 %		3.6 ±1 %	
3000	41.5 ±1 %		25.0 ±1 %		3.6 ±1 %	
3500	37.0 ±1 %		26.4 ±1 %		3.6 ±1 %	
3700	34.7 ±1 %		26.4 ±1 %		3.6 ±1 %	

7 VALIDATION MEASUREMENT

The IEEE Std. 1528, OET 65 Bulletin C and CEI/IEC 62209 standards state that the system validation measurements must be performed using a reference dipole meeting the fore mentioned return loss and mechanical dimension requirements. The validation measurement must be performed against a liquid filled flat phantom, with the phantom constructed as outlined in the fore mentioned standards. Per the standards, the dipole shall be positioned below the bottom of the phantom, with the dipole length centered and parallel to the longest dimension of the flat phantom, with the top surface of the dipole at the described distance from the bottom surface of the phantom.

7.1 HEAD LIQUID MEASUREMENT

Frequency MHz	Relative permittivity (ε <sub>r</sub> )		Conductivity (σ) S/m	
	required	measured	required	measured
300	45.3 ±5 %		0.87 ±5 %	
450	43.5 ±5 %		0.87 ±5 %	
750	41.9 ±5 %		0.89 ±5 %	
835	41.5 ±5 %		0.90 ±5 %	
900	41.5 ±5 %		0.97 ±5 %	
1450	40.5 ±5 %		1.70 ±5 %	
1500	40.4 ±5 %		1.23 ±5 %	
1540	40.2 ±5 %		1.31 ±5 %	
1750	40.1 ±5 %		1.37 ±5 %	
1800	40.3 ±5 %		1.40 ±5 %	
1900	40.0 ±5 %	PASS	1.40 ±5 %	PASS
1950	40.0 ±5 %		1.40 ±5 %	
2000	40.0 ±5 %		1.40 ±5 %	

Page: 7/11

*This document shall not be reproduced, copied in full or in part, without the written approval of SATIMA. The information contained herein is to be used only for the purpose for which it is submitted and is not to be retained in whole or part without written approval of SATIMA.*





SAR REFERENCE DIPOLE CALIBRATION REPORT

Ref: ACR-2015-15 SATIMA

2100	59.8 ±5 %		1.49 ±5 %	
2300	59.5 ±5 %		1.67 ±5 %	
2450	59.2 ±5 %		1.80 ±5 %	
2500	59.0 ±5 %		1.96 ±5 %	
3000	58.5 ±5 %		2.40 ±5 %	
3500	57.9 ±5 %		2.91 ±5 %	

7.2 SAR MEASUREMENT RESULT WITH HEAD LIQUID

The IEEE Std. 1528 and CEI/IEC 62209 standards state that the system validation measurements should produce the SAR values shown below (for phantom thickness of 2 mm), within the uncertainty for the system validation. All SAR values are normalized to 1 W forward power. In bracket, the measured SAR is given with the used input power.

Software	OPENSAR V4
Phantom	SN 20009 SAM71
Probe	SN 18/11 EPG122
Liquid	Head Liquid Values: eps' : 41.1 sigma : 1.42
Distance between dipole center and liquid	13.0 mm
Area scan resolution:	dx=8mm/dy=8mm
Zoon Scan Resolution	dx=8mm/dy=8mm/dz=5mm
Frequency	1900 MHz
Input power	23 dBm
Liquid Temperature	21 °C
Lab Temperature	21 °C
Lab Humidity	45 %

Frequency MHz	1 g SAR (W/kg/W)		10 g SAR (W/kg/W)	
	required	measured	required	measured
300	2.85		1.04	
450	4.58		3.26	
750	8.49		5.55	
835	9.56		5.27	
900	10.9		5.99	
1450	29		16	
1500	30.5		16.8	
1640	34.2		18.4	
1750	36.4		19.2	
1800	36.4		20.1	
1900	39.7	40.87 (4.04)	20.5	20.62 (2.06)
1950	40.5		20.9	
2000	41.1		21.1	
2100	43.6		21.9	
2300	48.7		23.3	

Page: 8/11

*This document shall not be reproduced, except in full or in part, without the written approval of SATIMO. The information contained herein is to be used only for the purpose for which it is submitted and is not to be released in whole or part without written approval of SATIMO.*



SAR REFERENCE DIPOLE CALIBRATION REPORT

Ref: ACR240.1.14 SATUCA

2450	52.4		24	
2900	55.3		24.6	
3000	63.8		25.7	
3500	67.1		25	

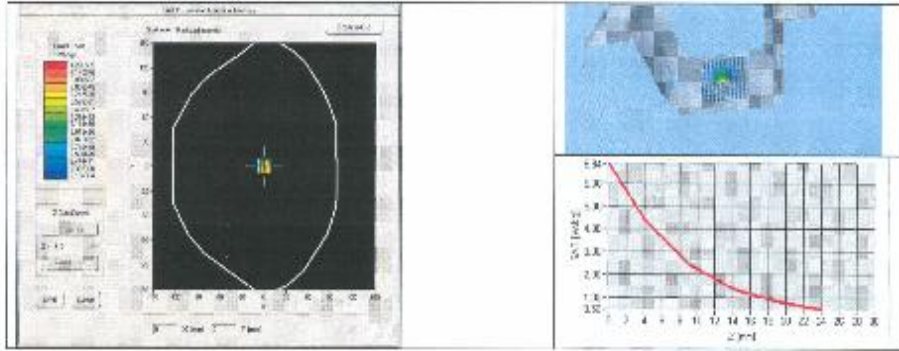

7.3 BODY LIQUID MEASUREMENT

Frequency MHz	Relative permittivity ( $\epsilon_r$ )		Conductivity ( $\sigma$ ) S/m	
	required	measured	required	measured
150	61.9 ±5 %		0.80 ±5 %	
300	58.7 ±5 %		0.93 ±5 %	
450	56.7 ±5 %		0.94 ±5 %	
750	55.5 ±5 %		0.96 ±5 %	
835	55.2 ±5 %		0.97 ±5 %	
900	55.0 ±5 %		1.05 ±5 %	
915	55.0 ±5 %		1.06 ±5 %	
1450	54.0 ±5 %		1.30 ±5 %	
1610	53.8 ±5 %		1.40 ±5 %	
1800	53.3 ±5 %		1.52 ±5 %	
1900	53.3 ±5 %	PASS	1.52 ±5 %	PASS
2000	53.3 ±5 %		1.52 ±5 %	
2100	53.2 ±5 %		1.62 ±5 %	
2450	52.7 ±5 %		1.95 ±5 %	
2600	52.5 ±5 %		2.16 ±5 %	
3000	52.0 ±5 %		2.73 ±5 %	
3500	51.3 ±5 %		3.31 ±5 %	
5200	49.0 ±10 %		5.30 ±10 %	
5300	48.9 ±10 %		5.42 ±10 %	
5400	48.7 ±10 %		5.53 ±10 %	

Page: 9/11

*This document shall not be reproduced, except in full or in part, without the written approval of SATIMO. The information contained herein is to be used only for the purpose for which it is submitted and is not to be released in whole or part without written approval of SATIMO.*



SAR REFERENCE DIPOLE CALIBRATION REPORT

Ref: ACR 060414SATIJA

5500	48.6 ±10 %		5.55 ±10 %
5600	48.5 ±10 %		5.77 ±10 %
5800	48.2 ±10 %		5.50 ±10 %

7.4 SAR MEASUREMENT RESULT WITH BODY LIQUID

Software	OPENSAR V4
Phantom	SN 20/09 SAM71
Probe	SN 18/11 EPX122
Liquid	Body Liquid Values: eps' : 54.2 sigma : 1.54
Distance between dipole center and liquid	10.0 mm
Area scan resolution	dx=8mm/dy=8mm
Z-scan Resolution	dz=8mm/dz=8mm/dz=5mm
Frequency	1900 MHz
Input power	20 dBm
Liquid Temperature	21 °C
Lab Temperature	21 °C
Lab Humidity	45 %

Frequency (MHz)	1 g SAR (W/kg/W)	10 g SAR (W/kg/W)
	measured	measured
1900	40.81 [4.08]	71.71 [2.12]

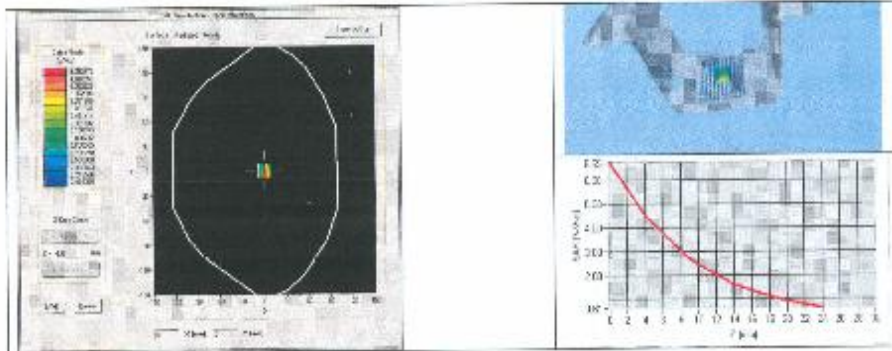



8 LIST OF EQUIPMENT

Equipment Summary Sheet				
Equipment Description	Manufacturer / Model	Identification No.	Current Calibration Date	Next Calibration Date
SAM Phantom	Satimo	SN-20/09-SAM71	Validated. No cal required.	Validated. No cal required.
COMOSAR Test Bench	Version 3	NA	Validated. No cal required.	Validated. No cal required.
Network Analyzer	Rhode & Schwarz ZVA	SN100132	02/2013	02/2016
Calipers	Camera	CALIPER-01	12/2013	12/2016
Reference Probe	Satimo	EPG122 SN 18/11	10/2013	10/2014
Multimeter	Keithley 2000	1188656	12/2013	12/2016
Signal Generator	Agilent E4438C	MY49070581	12/2013	12/2016
Amplifier	Aethercomm	SN 046	Characterized prior to test. No cal required.	Characterized prior to test. No cal required.
Power Meter	HP E4418A	US38261498	12/2013	12/2016
Power Sensor	HP ECP-E28A	US37181480	12/2013	12/2016
Directional Coupler	Narda 4216-20	01386	Characterized prior to test. No cal required.	Characterized prior to test. No cal required.
Temperature and Humidity Sensor	Control Company	11 661 9	8/2012	8/2015

This document shall not be reproduced, except in full or in part, without the written approval of SATIMO. The information contained herein is to be used only for the purpose for which it is submitted and is not to be released in whole or part without written approval of SATIMO.

**<Justification of the extended calibration>**

Referring to KDB 450824, if dipoles are verified in return loss(<-20dB, within 20% of prior calibration),and in impedance (within 5 ohm of prior calibration), the annual calibration is not necessary and the calibration interval can be extended.

Head 835MHz				
Date of Measurement	Return Loss (dB)	Delta (%)	Impedance	Delta(ohm)
2014.08.28	-23.17	-	57.40	-
2015.08.26	-22.96	4.95	57.88	0.48

The return loss is <-20dB, within 20% of prior calibration; the impedance is within 5 ohm of prior calibration. Therefore the verification result should support extended calibration.

**<Dipole Verification Data>**

**Head 835MHz**

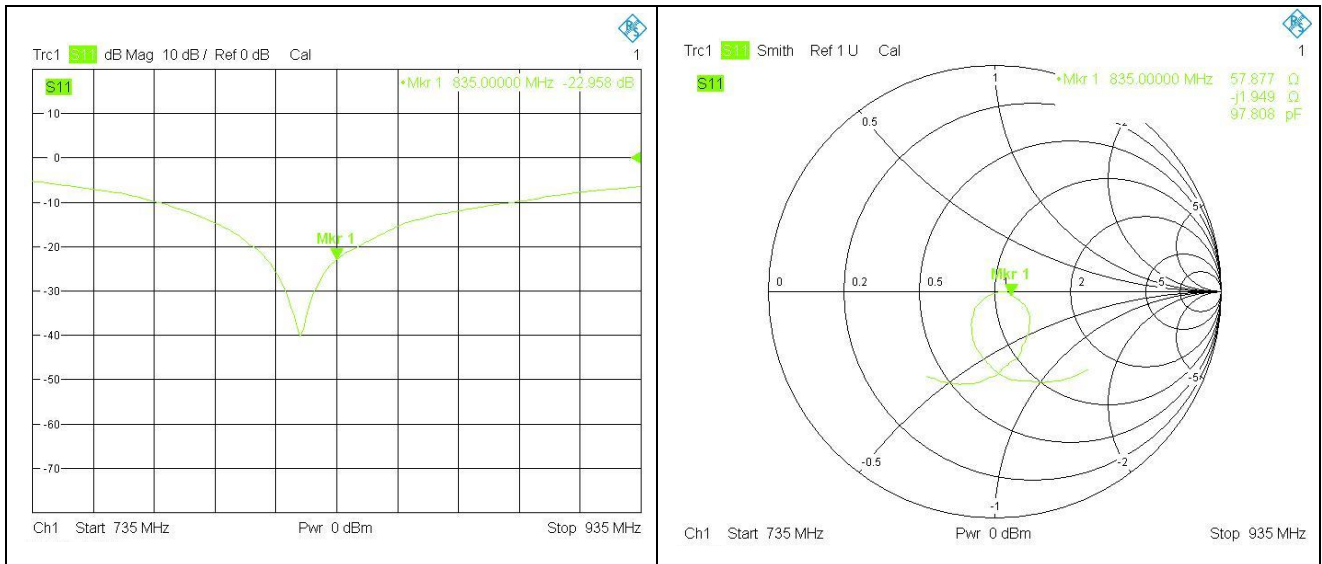

Body 835MHz				
Date of Measurement	Return Loss (dB)	Delta (%)	Impedance	Delta(ohm)
2014.08.28	-24.50	-	55.00	-
2015.08.26	-24.60	-2.28	55.06	0.06

The return loss is <-20dB, within 20% of prior calibration; the impedance is within 5 ohm of prior calibration. Therefore the verification result should support extended calibration.

<Dipole Verification Data>

Body 835MHz

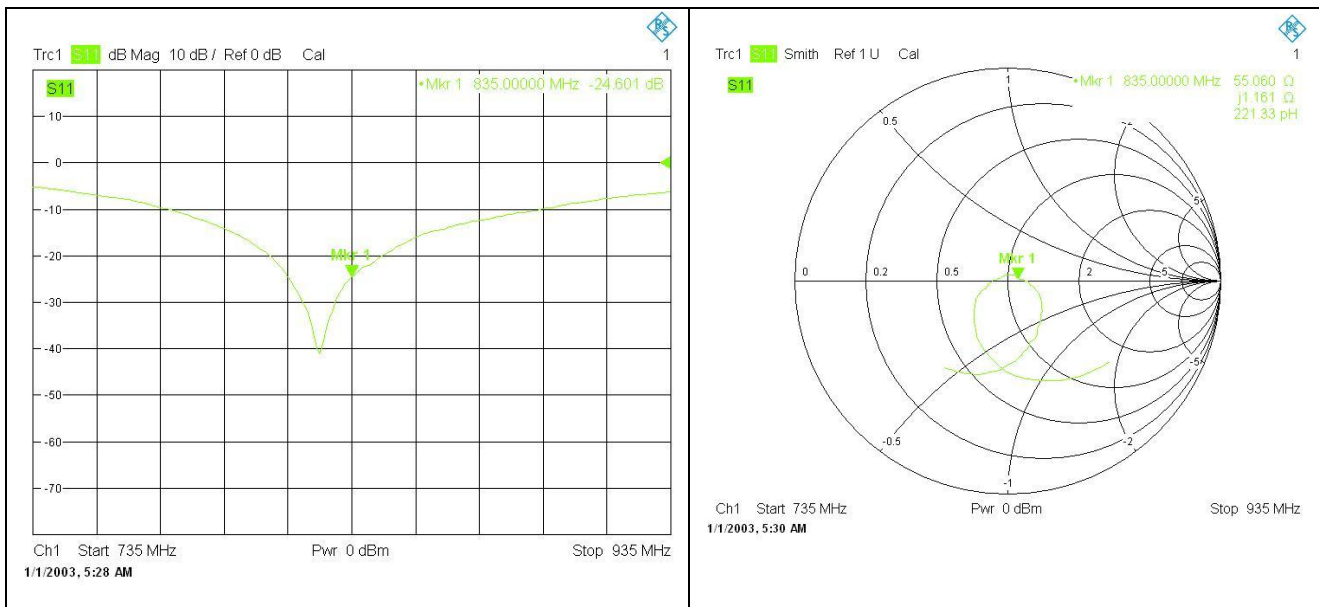

Head 1900MHz				
Date of Measurement	Return Loss (dB)	Delta (%)	Impedance	Delta(ohm)
2014.08.28	-23.44	-	55.40	-
2015.08.26	-23.79	-7.74	55.33	-0.07

The return loss is <-20dB, within 20% of prior calibration; the impedance is within 5 ohm of prior calibration. Therefore the verification result should support extended calibration.

<Dipole Verification Data>

Head 1900MHz

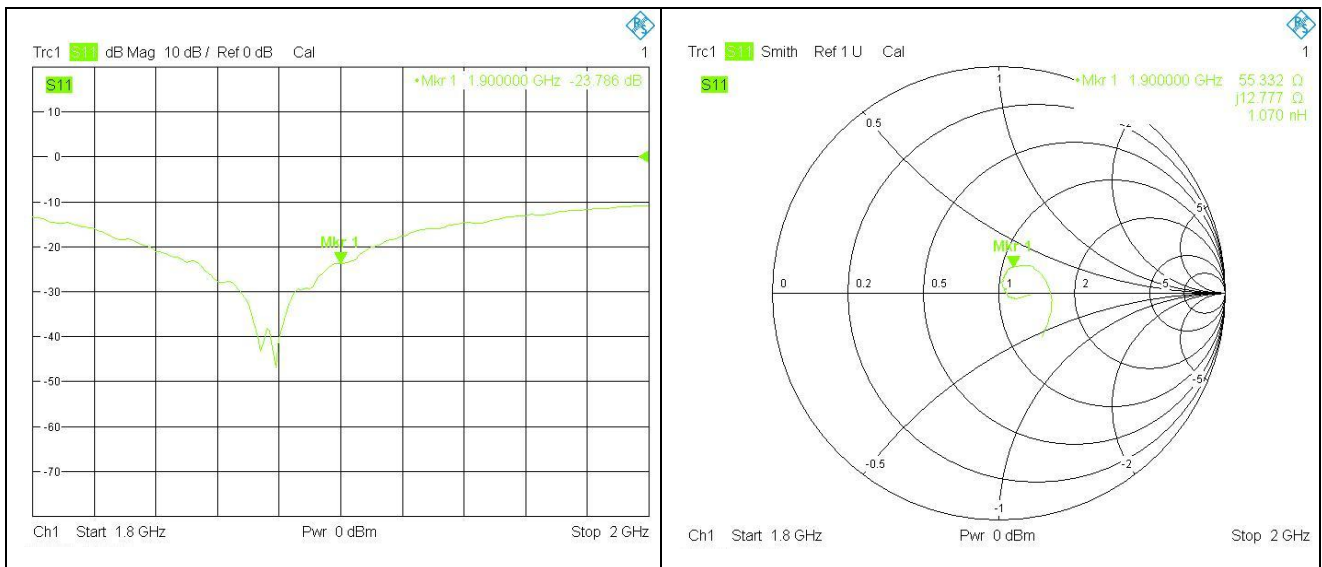

Body 1900MHz				
Date of Measurement	Return Loss (dB)	Delta (%)	Impedance	Delta(ohm)
2014.08.28	-27.36	-	51.70	-
2015.08.26	-26.94	10.15	51.18	-0.52

The return loss is <-20dB, within 20% of prior calibration; the impedance is within 5 ohm of prior calibration. Therefore the verification result should support extended calibration.

<Dipole Verification Data>

Body 1900MHz

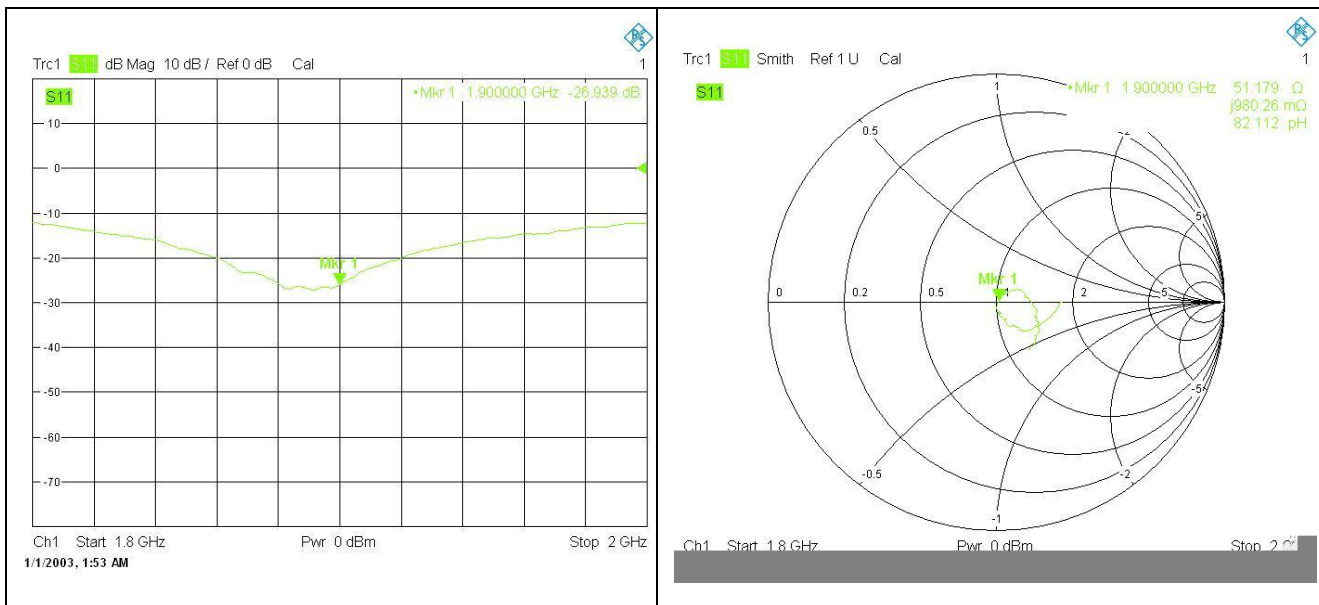

—End of the Report—