

FCC RF Test Report

For

Punkt Tronics AG

Test Standards: FCC 47 CFR Part 2, 22(H), 24(E), 27

Product Name: MC 02

Model Name: MC 02

Brand Name: Punkt.

FCC ID: Z3PMC02

Classification: PCS Licensed Transmitter Held to Ear (PCE)

Report No.: EC2312003RF01+A1

Tested Date: 2023-12-12 to 2024-01-26

Issued Date: 2024-02-04

Prepared By: 
Laxy Ruan / Engineer

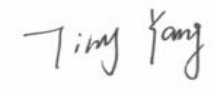
Approved By: 
Tiny Yang / RF Manager

Hunan Ecloud Testing Technology Co., Ltd.

Building A1, Changsha E Center, No. 18 Xiangtai Avenue, Liuyang Economic and Technological
Development Zone, Hunan, P.R.C

Tel.: +86-731-89634887 Fax.: +86-731-89634887

www.hn-ecloud.com

Note: The test results in this report apply exclusively to the tested model / sample. Without written approval of Hunan Ecloud Testing Technology Co., Ltd., the test report shall not be reproduced except in full.

Report Revise Record

Report Version	Revise Time	Issued Date	Valid Version	Notes
V1.0	/	2024-01-26	Void	Original Report
V1.1	2024-01-28	2024-02-04	Valid	Update Product Name and Applicant Address

TABLE OF CONTENTS

REPORT REVISE RECORD	2
TABLE OF CONTENTS	3
SUMMARY OF TEST RESULT	4
1 TEST LABORATORY	5
1.1 Test facility	5
2 GENERAL DESCRIPTION	6
2.1 Applicant	6
2.2 Manufacturer	6
2.3 Product Feature of Equipment Under Test	6
2.4 Product Specification of Equipment Under Test	7
2.5 Modification of EUT	8
2.6 Applicable Standards	8
3 TEST CONFIGURATION OF EQUIPMENT UNDER TEST	9
3.1 Test Item And Test Configuration	9
3.2 Connection Diagram of Test System	11
3.3 Support Unit used in test configuration	11
3.4 Measurement Results Explanation Example	12
3.5 Test Condition	12
4 TEST TYPES AND RESULTS	13
4.1 Conducted Output Power And E.R.P./E.I.R.P.	13
4.2 Frequency Stability	15
4.3 Peak-to-average Ratio	17
4.4 99% Occupied Bandwidth And 26dB Bandwidth	18
4.5 Conducted Band Edge Measurement	19
4.6 Conducted Spurious Emissions	21
4.7 Radiated Spurious Emissions	22
5 LIST OF MEASURING EQUIPMENT	26
6 UNCERTAINTY OF EVALUATION	27
7 PHOTOGRAPHS OF TEST SETUP	28
8 PHOTOGRAPHS OF EUT	29
APPENDIX : TEST RESULTS	30

Summary of Test Result

Report Section	Standard Section	Description	Result	Remark
4.1	§2.1046	Conducted Output Power	PASS	-
	§22.913(a)(5) §27.50(c)(10)	Equivalent Radiated Power (n5) (n12/n71)		
	§24.232(c) §27.50(d)(4) §27.50(h)(2)	Equivalent Isotropically Radiated Power (n2/n25) (n66) (n7/n41)		
4.2	§2.1055 §22.355 §24.235 §27.54	Frequency Stability	PASS	-
4.3	§22.913(d) §24.232(d) §27.50(d)(5)	Peak-to-average Ratio	PASS	-
4.4	§2.1049	Occupied Bandwidth	PASS	-
4.5	§2.1051 §22.917(a)(b) §24.238(a)(b) §27.53(g) §27.53(h)(1)(3) §27.53(m)(4)(6)	Conducted Band Edge Measurement (n5) (n2/n25) (n12/n71) (n66) (n7/n41)	PASS	-
4.6	§2.1051 §22.917(a)(b) §24.238(a)(b) §27.53(g) §27.53(h)(1)(3) §27.53(m)(4)(6)	Conducted Spurious Emissions (n5) (n2/n25) (n12/n71) (n66) (n7/n41)	PASS	-
4.7	§2.1053 §22.917(a)(b) §24.238(a)(b) §27.53(g) §27.53(h)(1)(3) §27.53(m)(4)(6)	Radiated Spurious Emissions (n5) (n2/n25) (n12/n71) (n66) (n7/n41)	PASS	-

1 Test Laboratory

1.1 Test facility

CNAS (Accreditation number: L11138)

Hunan Ecloud Testing Technology Co., Ltd. has obtained the accreditation of China National Accreditation Service for Conformity Assessment (CNAS).

FCC (Designation number: CN1244 , Test Firm Registration Number: 793308)

Hunan Ecloud Testing Technology Co., Ltd. has been listed on the US Federal Communications Commission list of test facilities recognized to perform electromagnetic emissions measurements.

ISED (CAB identifier: CN0012, ISED# :24347)

Hunan Ecloud Testing Technology Co., Ltd. has been listed on the Wireless Device Testing Laboratories list of innovation, Science and Economic Development Canada to test to Canadian radio equipment requirements.

A2LA (Certificate Code: 4895.01)

Hunan Ecloud Testing Technology Co., Ltd. has been listed by American Association for Laboratory Accreditation to perform electromagnetic emission measurement.

2 General Description

2.1 Applicant

Punkt Tronics AG

Via Losanna 4, 6900 Lugano, Switzerland

2.2 Manufacturer

UWIN INNOVATIOIN (HONG KONG)LIMITED

ROOM D 10/F TOWER A BILLION CENTRE 1 WANG KWONG RD KOWLOON BAY KL

2.3 Product Feature of Equipment Under Test

Product Feature	
Product Name	MC 02
Model Name	MC 02
Additional Model	N/A
Difference Description	N/A
Nominal Voltage	Li-ion Polymer Battery/ DC 3.85V
FCC ID	Z3PMC02
HW Version	N903B_MB_V1
SW Version	MC02.20231230.U0
Extreme Voltage	3.45 ~ 4.35 Vdc
Sample no.	2312003R-1/2~2/2
Sample Received Date	2023-12-11

Note:

1. The above EUT information is declared by manufacturer. Our laboratory is not responsible for the information provided by the manufacturer.
2. For a more detailed features description, please refer to the manufacturer's specifications or the user's manual.

2.4 Product Specification of Equipment Under Test

Standards-related Product Specification		
Modulation	DFT-s-OFDM	Pi/2 BPSK, QPSK, 16QAM, 64QAM, 256QAM
Technology	CP-OFDM	QPSK, 16QAM, 64QAM, 256QAM
Operation Band	n2	Only SA Mode
	n5	
	n7	
	n12	
	n25	
	n41	
	n66	
	n71	
Frequency Range	n2	1850MHz ~ 1910MHz
	n5	824MHz ~ 849MHz
	n7	2500MHz ~ 2570MHz
	n12	669MHz ~ 716MHz
	n25	1850MHz ~ 1915MHz
	n41	2496MHz ~ 2690MHz
	n66	1710MHz ~ 1780MHz
	n71	663MHz ~ 698MHz
Channel Bandwidth	n2(SCS=15kHz)	5MHz, 10MHz, 15MHz, 20MHz
	n5(SCS=15kHz)	5MHz, 10MHz, 15MHz, 20MHz
	n7(SCS=15kHz)	5MHz, 10MHz, 15MHz, 20MHz
	n12(SCS=15kHz)	5MHz, 10MHz, 15MHz
	n25(SCS=15kHz)	5MHz, 10MHz, 15MHz, 20MHz
	n41(SCS=30kHz)	10MHz, 15MHz, 20MHz, 30MHz, 40MHz, 50MHz, 60MHz, 80MHz, 90MHz, 100MHz
	n66(SCS=15kHz)	5MHz, 10MHz, 15MHz, 20MHz, 25MHz, 30MHz, 40MHz
	n71(SCS=15kHz)	5MHz, 10MHz, 15MHz, 20MHz
Maximum E.R.P.	n5	147.91 mW
	n12	98.17 mW
	n71	96.16 mW
Maximum E.I.R.P.	n2	257.04 mW
	n7	273.53 mW
	n25	338.84 mW
	n41	285.76 mW
	n66	318.42 mW
Antenna Type/ Gain	n2	FPC Antenna with 0.41 dBi gain
	n5	FPC Antenna with -0.95 dBi gain
	n7	FPC Antenna with -0.67 dBi gain

	n12	FPC Antenna with -2.51 dBi gain
	n25	FPC Antenna with 0.41 dBi gain
	n41	FPC Antenna with -0.57 dBi gain
	n66	FPC Antenna with 0.24 dBi gain
	n71	FPC Antenna with -2.51 dBi gain

Note:

1. The above EUT information is declared by manufacturer. Our laboratory is not responsible for the information provided by the manufacturer.
2. For the test results, the EUT had been tested with all conditions. But only the worst case was shown in test report.

2.5 Modification of EUT

No modifications are made to the EUT during all test items.

2.6 Applicable Standards

According to the specifications of the manufacturer, the EUT must comply with the requirements of the following standards:

- ♦ FCC 47 CFR Part 2, 22(H), 24(E), 27
- ♦ FCC KDB 971168 D01 Power Meas License Digital Systems v03r01
- ♦ FCC KDB 412172 D01 Determining ERP and EIRP v01r01
- ♦ FCC KDB 414788 D01 Radiated Test Site v01r01
- ♦ ANSI/TIA-603-E-2016
- ♦ ANSI C63.26-2015

Note:

1. All test items were verified and recorded according to the standards and without any deviation during the test.
2. This EUT has also been tested and complied with the requirements of FCC Part 15, Subpart B recorded in a separate test report.

3 Test Configuration of Equipment Under Test

3.1 Test Item And Test Configuration

Antenna port conducted and radiated test items listed below are performed according to KDB 971168 D01 Power Meas License Digital Systems v03r01 with maximum output power.

Pre-Scan has been conducted to determine the worst-case mode from all possible combinations between available modulations, data rates, XYZ axis and antenna ports. The worst case was found when positioned on Z-axis for radiated emission. Following configuration was selected for the final test as listed below:

Test Item	Channel	Bandwidth	Mode	Modulation	RB Allocation
Conducted Output Power And E.R.P./E.I.R.P.	Low,Middle, High	All	DFT-s-OFDM	Pi/2 BPSK, QPSK, 16QAM, 64QAM, 256QAM	Outer_Full Inner_Full Inner_1RB_Left Inner_1RB_Right
			CP-OFDM	QPSK, 16QAM, 64QAM, 256QAM	
Frequency Stability	Middle	High	DFT-s-OFDM	Pi/2 BPSK	Outer_Full
Peak-to-average Ratio	Middle	High or 20M	DFT-s-OFDM	Pi/2 BPSK, QPSK, 16QAM, 64QAM, 256QAM	Outer_Full
99% Occupied Bandwidth And 26dB Bandwidth	Middle	All	DFT-s-OFDM	Pi/2 BPSK	Outer_Full
			CP-OFDM	QPSK, 16QAM, 64QAM, 256QAM	
Conducted Band Edge Measurement	Low	All	DFT-s-OFDM	Pi/2 BPSK, QPSK, 16QAM, 64QAM, 256QAM	Edge_1RB_Left Outer_Full
			CP-OFDM	QPSK	Outer_Full
	High	All	DFT-s-OFDM	Pi/2 BPSK, QPSK, 16QAM, 64QAM, 256QAM	Edge_1RB_Right Outer_Full
			CP-OFDM	QPSK	Outer_Full

Conducted Spurious Emissions	Low,Middle, High	High	DFT-s-OFDM	Pi/2 BPSK	Edge_1RB_Left Edge_1RB_Right Outer_Full
Radiated Spurious Emissions	Worst Case				1RB

Note:

1. This device was tested under all bandwidths, RB configurations and modulations. Only the worst case configuration was listed.
2. One representative bandwidth is selected to perform Frequency Stability, PAR and Conducted Spurious Emissions.
3. For radiated measurement, pre-scanned in two modes: DFT-s-OFDM and CP-OFDM. The worst case (DFT-s-OFDM) was recorded in this report.

3.2 Connection Diagram of Test System

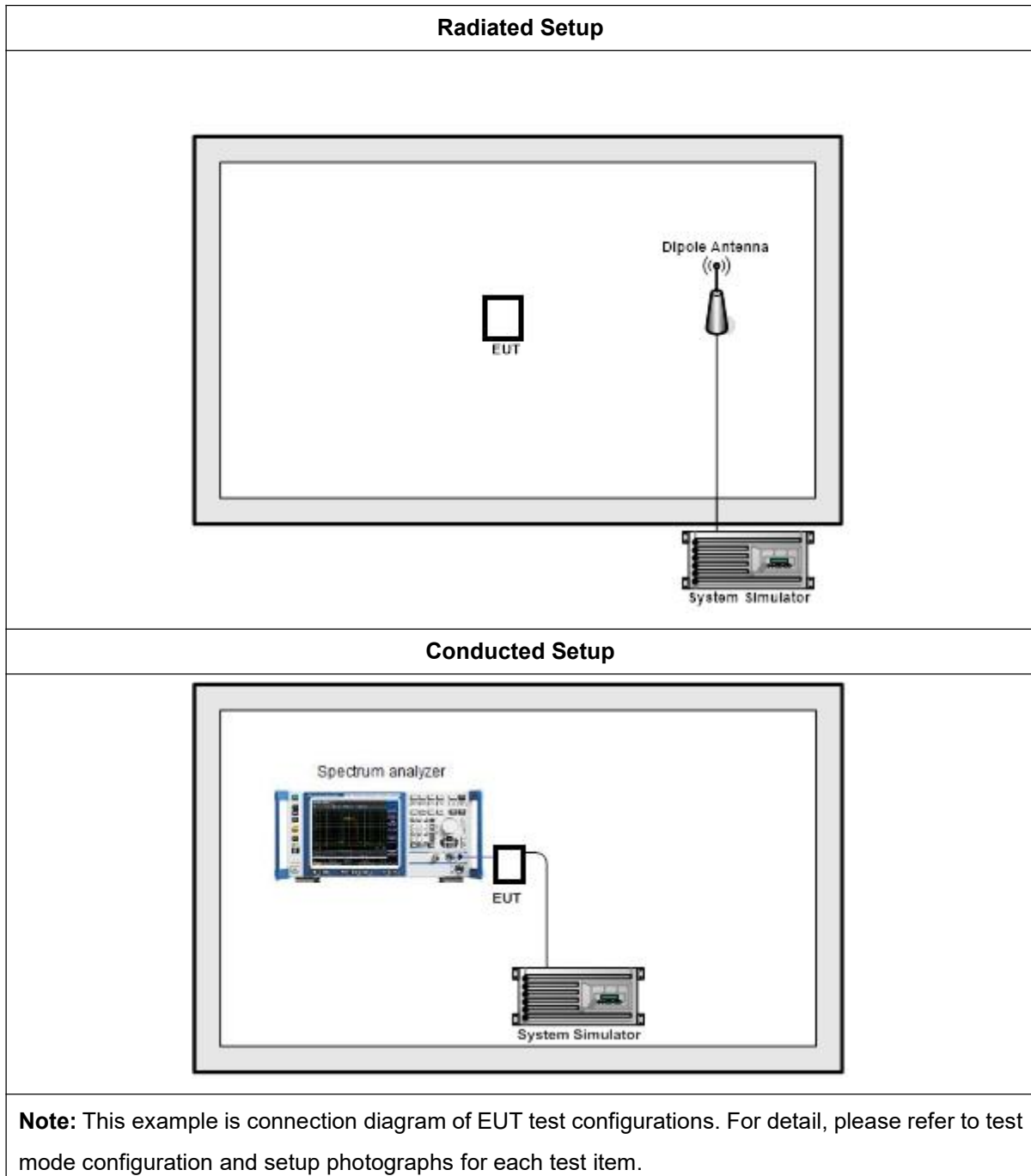

3.3 Support Unit used in test configuration

Item	Equipment	Trade Name	Model No.	FCC ID	Data Cable	Power Cord
1	DC Power Supply	Keysight	E3642A	N/A	N/A	Unshielded, 1.8 m

3.4 Measurement Results Explanation Example

For all conducted test items:

The offset level is set in the spectrum analyzer to compensate the RF cable loss and attenuator factor between RF conducted output port and spectrum analyzer. With the offset compensation, the spectrum analyzer reading level will be exactly the RF output level.

The spectrum analyzer offset is derived from RF cable loss and attenuator factor.

Offset = RF cable loss + attenuator factor.

The following shows an offset computation example with RF cable loss 4.5 dB and a 10dB attenuator.

Example :

$$\begin{aligned} \text{Offset(dB)} &= \text{RF cable loss(dB)} + \text{attenuator factor(dB)}. \\ &= 4.5 + 10 = 14.5 \text{ (dB)} \end{aligned}$$

3.5 Test Condition

Test Item	Environmental Condition	Input Power	Test Engineer
Conducted Output Power And E.R.P./E.I.R.P.	20 ~ 25 deg. C, 55 ~ 70% RH	EUT 3.85V	Laxy Ruan
Frequency Stability	20 deg. C, 55 ~ 70% RH	EUT 3.45V/ 3.85V/ 4.35V	Laxy Ruan
	-30 ~ 50 deg. C, 55 ~ 70% RH	EUT 3.85V	Laxy Ruan
Peak-to-average Ratio	20 ~ 25 deg. C, 55 ~ 70% RH	EUT 3.85V	Laxy Ruan
99% Occupied Bandwidth And 26dB Bandwidth	20 ~ 25 deg. C, 55 ~ 70% RH	EUT 3.85V	Laxy Ruan
Conducted Band Edge Measurement	20 ~ 25 deg. C, 55 ~ 70% RH	EUT 3.85V	Laxy Ruan
Conducted Spurious Emissions	20 ~ 25 deg. C, 55 ~ 70% RH	EUT 3.85V	Laxy Ruan
Radiated Spurious Emissions	20 ~ 25 deg. C, 55 ~ 70% RH	EUT 3.85V	Jack Liu

4 Test Types And Results

4.1 Conducted Output Power And E.R.P./E.I.R.P.

4.1.1 Limit

§22.913(a)(5) - The ERP of mobile transmitters and auxiliary test transmitters must not exceed 7 watts. (n5)

§24.232(c) - Mobile and portable stations are limited to 2 watts EIRP and the equipment must employ a means for limiting power to the minimum necessary for successful communications. (n2/n25)

§27.50(c)(10) - Portable stations (hand-held devices) in the 600 MHz uplink band and the 698 – 746 MHz band, and fixed and mobile stations in the 600 MHz uplink band are limited to 3 watts ERP. (n12/n71)

§27.50(d)(4) - Fixed, mobile, and portable (hand-held) stations operating in the 1710 – 1755 MHz band and mobile and portable stations operating in the 1695 – 1710 MHz and 1755 – 1780 MHz bands are limited to 1 watt EIRP. (n66)

§27.50(h)(2) - Mobile stations are limited to 2.0 watts EIRP. All user stations are limited to 2.0 watts transmitter output power. (n7/n41)

4.1.2 Test Procedures

Conducted Output Power Measurement

1. The transmitter output port was connected to the system simulator.
2. Set EUT at maximum power through the system simulator.
3. Select lowest, middle, and highest channels for each band and different modulation.
4. Measure and record the power level from the system simulator.

ERP/EIRP Measurement

Per KDB 971168 D01 Power Meas License Digital Systems v03r01 or subclause 5.2.5.5 of ANSI C63.26-2015, the relevant equation for determining the ERP or EIRP from the conducted RF output power measured using the guidance provided above is:

$$\text{ERP or EIRP} = P_{\text{Meas}} + G_{\text{T}} - L_{\text{C}}$$

Where:

ERP or EIRP = effective radiated power or equivalent isotropically radiated power, respectively

(expressed in the same units as P_{Meas} , typically dBW or dBm);

P_{Meas} = measured transmitter output power or PSD, in dBm or dBW;

G_{T} = gain of the transmitting antenna, in dBd (ERP) or dBi (EIRP);

L_{C} = signal attenuation in the connecting cable between the transmitter and antenna, in dB.

4.1.3 Test Setup

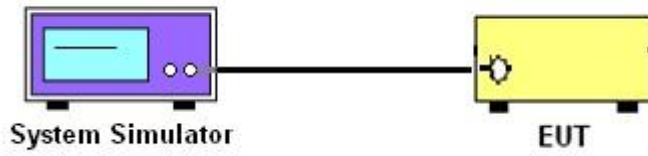

4.1.4 Test Results

Please refer to section 1 of Appendix C~J of this test report.

4.2 Frequency Stability

4.2.1 Limit

§22.355 - The limit are shown in the table below:

Frequency range (MHz)	Base, fixed (ppm)	Mobile > 3 watts (ppm)	Mobile ≤ 3 watts (ppm)
25 to 50	20.0	20.0	50.0
50 to 450	5.0	5.0	50.0
450 to 512	2.5	5.0	5.0
821 to 896	1.5	2.5	2.5
928 to 929	5.0	n/a	n/a
929 to 960	1.5	n/a	n/a
2110 to 2220	10.0	n/a	n/a

§24.235 & §27.54 - The frequency stability shall be sufficient to ensure that the fundamental emissions stay within the authorized bands of operation.

4.2.2 Test Condition

Temp. = -30° to +50°C

Voltage = (85% - 115%)

4.2.3 Test Procedures for Temperature Variation

1. The testing follows ANSI C63.26-2015 section 5.6.4.
2. The EUT was set up in the thermal chamber and connected with the system simulator.
3. With power OFF, the temperature was decreased to -30°C and the EUT was stabilized before testing. Power was applied and the maximum change in frequency was recorded within one minute.
4. With power OFF, the temperature was raised in 10°C steps up to 50°C. The EUT was stabilized at each step for at least half an hour. Power was applied and the maximum frequency change was recorded within one minute.

4.2.4 Test Procedures for Voltage Variation

1. The testing follows ANSI C63.26-2015 section 5.6.5.
2. The EUT was placed in a temperature chamber at 20±5° C and connected with the system simulator.
3. The power supply voltage to the EUT was varied from 85% to 115% of the nominal value measured at the input to the EUT.
4. Record the maximum frequency change.

4.2.5 Test Setup

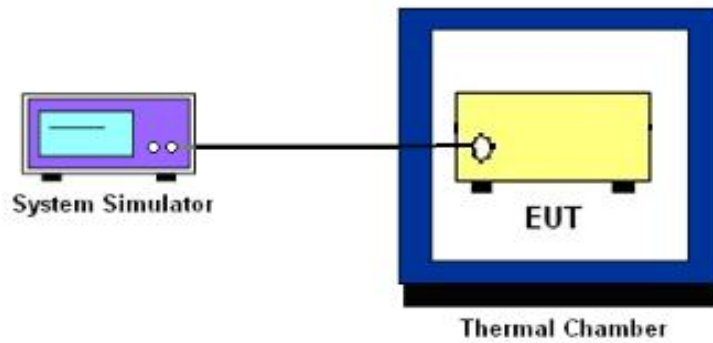

4.2.6 Test Results

Please refer to section 2 of Appendix C~J of this test report.

4.3 Peak-to-average Ratio

4.3.1 Limit

In measuring transmissions in this band using an average power technique, the peak-to-average ratio (PAR) of the transmission may not exceed 13 dB.

4.3.2 Test Procedures

1. The testing follows ANSI C63.26-2015 Section 5.2.3.4 (CCDF).
2. The EUT was connected to spectrum analyzer and system simulator via a power divider.
3. Set EUT to transmit at maximum output power.
4. The signal analyzer's CCDF measurement profile is enabled.
5. Frequency = carrier center frequency.
6. Measurement BW > emission bandwidth of signal.
7. When the duty cycle is less than 98%, then signal gating will be implemented on the spectrum analyzer by triggering from the system simulator.
8. Set the CCDF (Complementary Cumulative Distribution Function) option of the spectrum analyzer.
9. Record the maximum PAPR level associated with a probability of 0.1%.

4.3.3 Test Setup

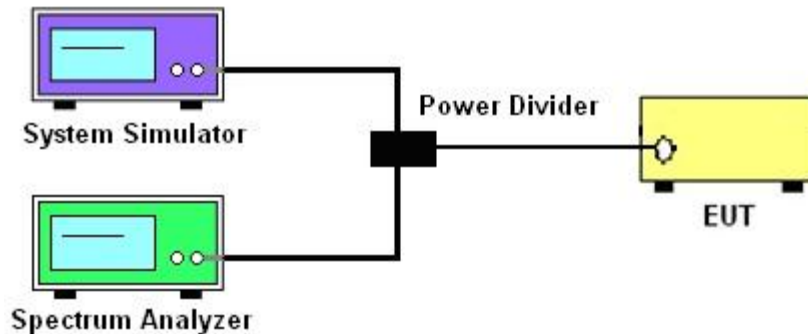

4.3.4 Test Results

Please refer to section 3 of Appendix C~J of this test report.

4.4 99% Occupied Bandwidth And 26dB Bandwidth

4.4.1 Limit

For reporting purposes only.

4.4.2 Test Procedures

1. The testing follows Sub clause 5.4.3 and Sub clause 5.4.4 of ANSI C63.26-2015.
2. The EUT was connected to spectrum analyzer and system simulator via a power divider.
3. The signal analyzer's automatic bandwidth measurement capability was used to perform the 99% occupied bandwidth and the 26dB bandwidth the bandwidth measurement was not influenced by any intermediate power nulls in the fundamental emission.
4. RBW = 1%~5% of the expected OBW, VBW $\geq 3 \times$ RBW.
5. Set the detection mode to peak, and the trace mode to max hold.
6. Determine the reference value: Set the EUT to transmit a modulated signal. Allow the trace to stabilize. Set the spectrum analyzer marker to the highest level of the displayed trace.(this is the reference value).
7. Determine the "-26 dB down amplitude" as equal to (Reference Value - X).
8. Place two markers, one at the lowest and the other at the highest frequency of the envelope of the spectral display such that each marker is at or slightly below the "-X dB down amplitude" determined in step 6. If a marker is below this "-X dB down amplitude" value it shall be placed as close as possible to this value. The OBW is the positive frequency difference between the two markers.
9. Use the 99 % power bandwidth function of the spectrum analyzer and record the measured bandwidth.

4.4.3 Test Setup

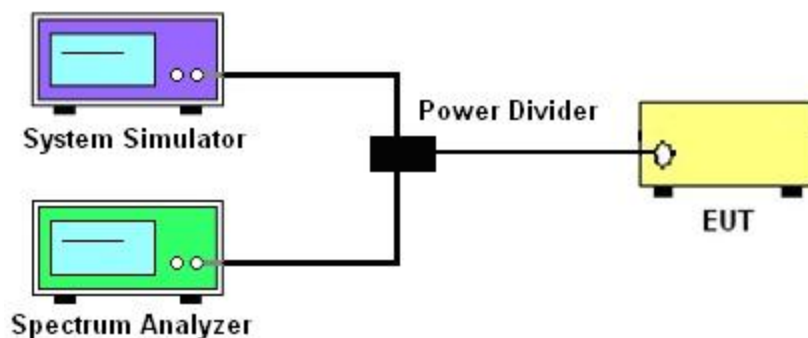

4.4.4 Test Results

Please refer to section 4 of Appendix C~J of this test report.

4.5 Conducted Band Edge Measurement

4.5.1 Limit

§22.917(a)(b) - The power of any emission outside of the authorized operating frequency ranges must be attenuated below the transmitting power (P) by a factor of at least $43 + 10 \log(P)$ dB. In the 1 MHz bands immediately outside and adjacent to the frequency block, a resolution bandwidth of at least one percent of the emission bandwidth of the fundamental emission of the transmitter may be employed. (n5)

§24.238(a)(b) - The power of any emission outside of the authorized operating frequency ranges must be attenuated below the transmitting power (P) by a factor of at least $43 + 10 \log(P)$ dB. However, in the 1 MHz bands immediately outside and adjacent to the frequency block a resolution bandwidth of at least one percent of the emission bandwidth of the fundamental emission of the transmitter may be employed. (n2/n25)

§27.53(g) - For operations in the 600 MHz band and the 698 – 746 MHz band, the power of any emission outside a licensee's frequency band(s) of operation shall be attenuated below the transmitter power (P) within the licensed band(s) of operation, measured in watts, by at least $43 + 10 \log(P)$ dB. Compliance with this provision is based on the use of measurement instrumentation employing a resolution bandwidth of 100 kilohertz or greater. However, in the 100 kilohertz bands immediately outside and adjacent to a licensee's frequency block, a resolution bandwidth of at least 30 kHz may be employed. (n12/n71)

§27.53(h)(1)(3) - For operations in the 1710 – 1755 MHz, 1755 – 1780 MHz, the power of any emission outside a licensee's frequency block shall be attenuated below the transmitter power (P) in watts by at least $43 + 10 \log_{10}(P)$ dB. Compliance with this provision is based on the use of measurement instrumentation employing a resolution bandwidth of 1 megahertz or greater. However, in the 1 megahertz bands immediately outside and adjacent to the licensee's frequency block, a resolution bandwidth of at least one percent of the emission bandwidth of the fundamental emission of the transmitter may be employed. (n66)

§27.53(m)(4)(6) - For mobile digital stations, the attenuation factor shall be not less than $40 + 10 \log(P)$ dB on all frequencies between the channel edge and 5 megahertz from the channel edge, $43 + 10 \log(P)$ dB on all frequencies between 5 megahertz and X megahertz from the channel edge, and $55 + 10 \log(P)$ dB on all frequencies more than X megahertz from the channel edge, where X is the greater of 6 megahertz or the actual emission bandwidth as defined in paragraph (m)(6) of this section. In addition, the attenuation factor shall not be less than $43 + 10 \log(P)$ dB on all frequencies between 2490.5 MHz and 2496 MHz and $55 + 10 \log(P)$ dB at or below 2490.5 MHz. Mobile Satellite Service

licensees operating on frequencies below 2495 MHz may also submit a documented interference complaint against BRS licensees operating on channel BRS Channel 1 on the same terms and conditions as adjacent channel BRS or EBS licensees. For mobile digital stations, in the 1 megahertz bands immediately outside and adjacent to the frequency block a resolution bandwidth of at least two percent may be employed, except when the 1 megahertz band is 2495 – 2496 MHz, in which case a resolution bandwidth of at least one percent may be employed. (n7/n41)

4.5.2 Test Procedures

1. The testing follows ANSI C63.26-2015 Section 5.7.
2. The EUT was connected to the spectrum analyzer and system simulator via a power divider.
3. Start and stop frequency were set such that the band edge would be placed in the center of the plot.
4. Span was set large enough so as to capture all out of band emissions near the band edge.
5. Set the RBW as required by applicable regulations, $VBW \geq 3 \times RBW$.
6. Detector = RMS.
7. Number of sweep points $\geq 2 \times \text{Span}/RBW$.
8. The trace was allowed to stabilize.
9. The RF fundamental frequency should be excluded against the limit line in the operating frequency band.
10. Checked that all the results comply with the limit.

4.5.3 Test Setup

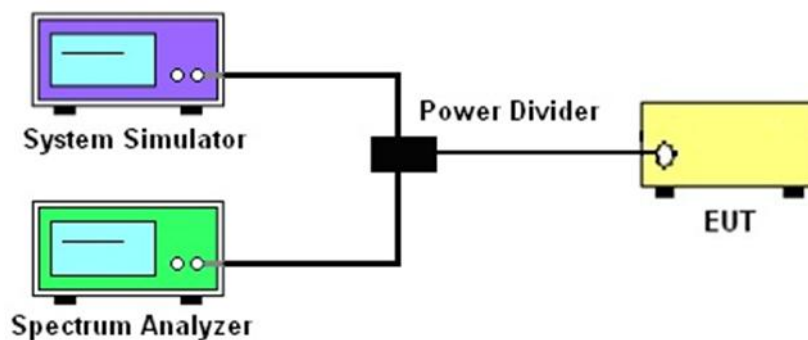

4.5.4 Test Results

Please refer to section 5 of Appendix C~J of this test report.

4.6 Conducted Spurious Emissions

4.6.1 Limit

The power of any emission outside a licensee's frequency block shall be attenuated below the transmitter power (P) by at least $43 + 10 \log(P)$ dB. The limit of emission is equal to -13dBm.

For 5G NR n7/n41, the power of any emission outside a licensee's frequency block shall be attenuated below the transmitter power (P) by at least $55 + 10 \log(P)$ dB. The limit of emission is equal to -25dBm.

4.6.2 Test Procedures

1. The testing follows ANSI C63.26-2015 section 5.7.
2. The EUT was connected to the spectrum analyzer and system simulator via a power divider.
3. The RF output of EUT was connected to the spectrum analyzer by an RF cable and attenuator.
The path loss was compensated to the results for each measurement.
4. The conducted spurious emission for the whole frequency range was taken.
5. Set the RBW as required by applicable regulations, $VBW \geq 3 \times RBW$.
6. Detector = RMS.
7. Taking the record of maximum spurious emission.
8. The RF fundamental frequency should be excluded against the limit line in the operating frequency band.
9. Checked that all the results comply with the limit.

4.6.3 Test Setup

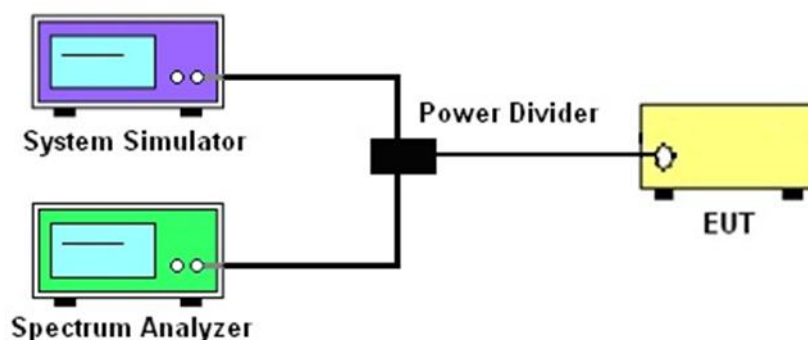

4.6.4 Test Results

Please refer to section 6 of Appendix C~J of this test report.

Note: The 9K~30MHz amplitude of spurious emissions attenuated more than 20 dB below the permissible value is not reported in the report.

4.7 Radiated Spurious Emissions

4.7.1 Limit

The power of any emission outside a licensee's frequency block shall be attenuated below the transmitter power (P) by at least $43 + 10 \log(P)$ dB. The limit of emission is equal to -13dBm.

For 5G NR n7/n41, the power of any emission outside a licensee's frequency block shall be attenuated below the transmitter power (P) by at least $55 + 10 \log(P)$ dB. The limit of emission is equal to -25dBm.

The spectrum is scanned from 9 KHz up to a frequency including its 10th harmonic or to 40 GHz, whichever is lower.

4.7.2 Test Procedures

The testing follows FCC KDB 971168 D01 v03r01 Section 7 and ANSI/TIA-603-E-2016 Section 2.2.12.

Below 1GHz test procedure as below:

1. The EUT was powered ON and placed on a 80cm high table in the chamber. The antenna of the transmitter was extended to its maximum length.
2. Set the RBW as required by applicable regulations, $VBW \geq 3 \times RBW$, taking record of maximum spurious emission.
3. The disturbance of the transmitter was maximized on the test receiver display by raising and lowering from 1m to 4m (for the test frequency of below 30MHz, the antenna was tuned to heights 1 meter) the receive antenna and by rotating through 360° the turntable. After the fundamental emission was maximized, a field strength measurement was made.
4. Steps 1) to 3) were performed with the EUT and the receive antenna in both vertical and horizontal polarization.
5. The transmitter was then removed and replaced with another antenna. The center of the antenna was approximately at the same location as the center of the transmitter.
6. A signal at the disturbance was fed to the substitution antenna by means of a non-radiating cable. With both the substitution and the receive antennas horizontally polarized, the receive antenna was raised and lowered to obtain a maximum reading at the test receiver. The level of the signal generator was adjusted until the measured field strength level in step 3) is obtained for this set of conditions.
7. The output power into the substitution antenna was then measured.
8. Steps 5) to 7) were repeated with both antennas polarized.
9. Calculate power in dBm by the following formula:

$$ERP(\text{dBm}) = P_g(\text{dBm}) - \text{cable loss (dB)} + \text{antenna gain (dBd)}$$

Where:

P_g is the generator output into the substitution antenna, and the antenna gain is the gain of the substitute antenna used relative to either a half-wave dipole (dBd) or an isotropic source (dBi).

The substitute level is equal to P_g (dBm) – cable loss (dB).

10. The calculated ERP are then compared to the absolute spurious emission limit.

Above 1GHz test procedure as below:

1. The EUT was powered ON and placed on a 150cm high table in the chamber. The antenna of the transmitter was extended to its maximum length.
2. Make the measurement with the spectrum analyzer's RBW = 1MHz, VBW = 3MHz, taking record of maximum spurious emission.
3. The disturbance of the transmitter was maximized on the test receiver display by raising and lowering from 1m to 4m the receive antenna and by rotating through 360° the turntable. After the fundamental emission was maximized, a field strength measurement was made.
4. Steps 1) to 3) were performed with the EUT and the receive antenna in both vertical and horizontal polarization.
5. The transmitter was then removed and replaced with another antenna. The center of the antenna was approximately at the same location as the center of the transmitter.
6. A signal at the disturbance was fed to the substitution antenna by means of a non-radiating cable. With both the substitution and the receive antennas horizontally polarized, the receive antenna was raised and lowered to obtain a maximum reading at the test receiver. The level of the signal generator was adjusted until the measured field strength level in step 3) is obtained for this set of conditions.
7. The output power into the substitution antenna was then measured.
8. Steps 5) to 7) were repeated with both antennas polarized.
9. Calculate power in dBm by the following formula:

$$\text{EIRP(dBm)} = P_g(\text{dBm}) - \text{cable loss (dB)} + \text{antenna gain (dBi)}$$

Where:

P_g is the generator output into the substitution antenna, and the antenna gain is the gain of the substitute antenna used relative to either a half-wave dipole (dBd) or an isotropic source (dBi).

The substitute level is equal to P_g (dBm) – cable loss (dB).

10. The calculated EIRP are then compared to the absolute spurious emission limit.

4.7.3 Test Setup

For radiated test below 30MHz

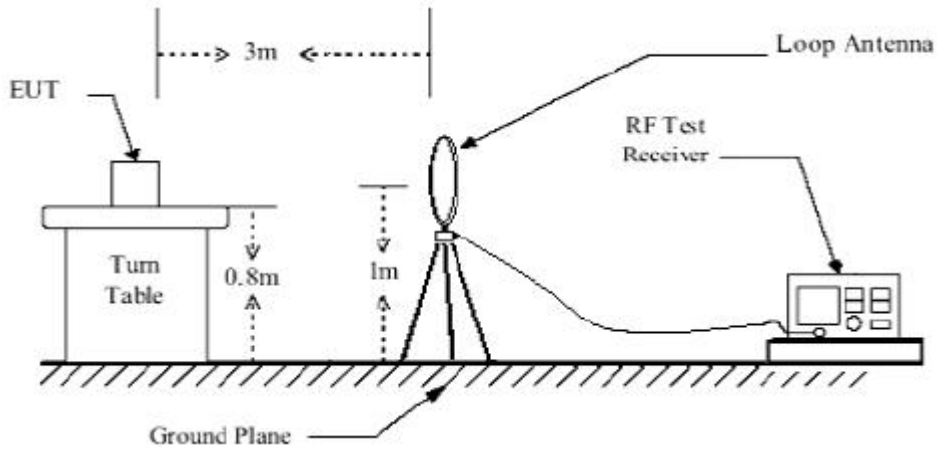

For radiated test from 30MHz to 1GHz

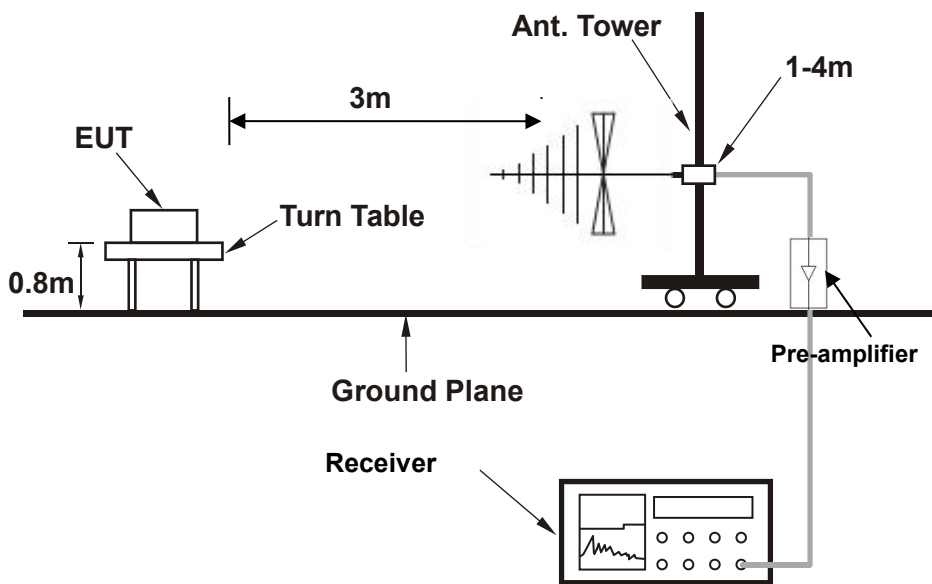

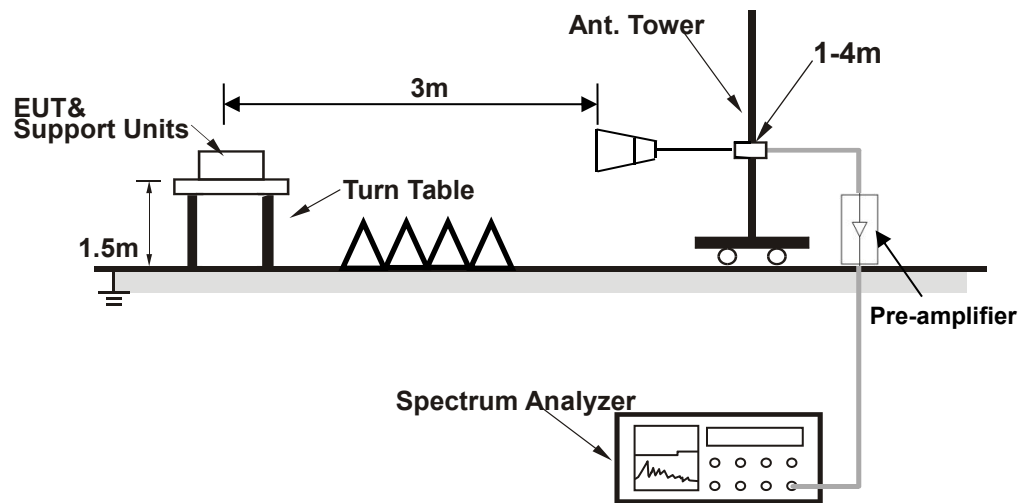
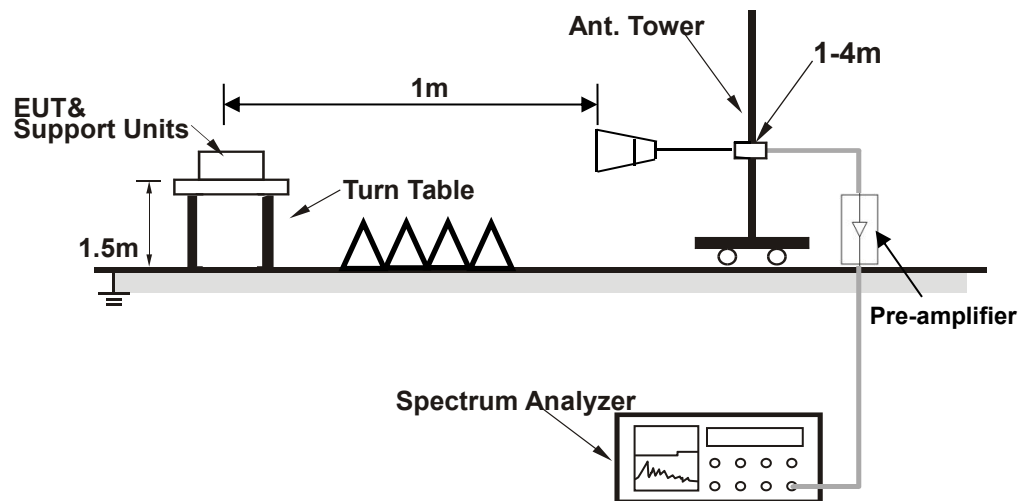
For radiated test from 1GHz to 18GHz**For radiated test above 18GHz****4.7.4 Test Results**

Please refer to section 7 of Appendix C~J of this test report.

Note:

1. The 9K~30MHz amplitude of spurious emissions attenuated more than 20 dB below the permissible value is not reported in the report.
2. For higher frequency(above 18GHz), the emission is too low to be detected.

5 List of Measuring Equipment

Instrument	Manufacturer	Model No.	Serial No.	Calibration Date	Due Date
Spectrum Analyzer	R&S	FSV40	101433	2023/12/19	2024/12/18
Spectrum Analyzer	Keysight	N9010A	MY56070788	2023/12/19	2024/12/18
Base Station	Anritsu	MT8000A	6272524676	2023/04/13	2024/04/12
Base Station	Anritsu	MT8821C	6272498373	2023/04/13	2024/04/12
Thermal Chamber	Howkin	UHL-34	19111801	2023/12/18	2024/12/17
Spectrum Analyzer	R&S	FSV30	103728	2023/12/19	2024/12/18
Amplifier	Sonoma	310	363917	2023/12/19	2024/12/18
Amplifier	Schwarzbeck	BBV 9718	327	2023/12/19	2024/12/18
Amplifier	Narda	TTA1840-35-HG	2034380	2024/01/03	2025/01/02
Loop Antenna	Schwarzbeck	FMZB 1519 B	00051	2023/02/12	2026/02/11
Broadband Antenna	Schwarzbeck	VULB 9168	9168-757	2023/09/17	2026/09/16
Horn Antenna	Schwarzbeck	BBHA 9120 D	01677	2023/02/12	2026/02/11
Horn Antenna	Schwarzbeck	BBHA 9120 D	02420	2021/12/26	2024/12/25
Horn Antenna	COM-POWER	AH-1840	101117	2021/06/05	2024/06/04
Signal Generator	R&S	SMB100A	180717	2023/12/19	2024/12/18
Test Software	Audix	E3	6.111221a	N/A	N/A
Filter Box	MWRFtest	MW500-SFCB	MW230227YUNP	N/A	N/A
RF Control Box	MWRFtest	MW500-RFCB	MW230228YUNP	N/A	N/A

Note:N/A is not required for calibration.

6 Uncertainty of Evaluation

Where relevant, the following measurement uncertainty levels have been estimated for tests performed on the EUT as specified in CISPR 16-4-2:

MEASUREMENT	UNCERTAINTY
Frequency Stability	$\pm 355.6\text{Hz}$
Radiated emissions & Radiated Power (30MHz~1GHz)	$\pm 2.49\text{dB}$
Radiated emissions & Radiated Power (1GHz ~6GHz)	$\pm 3.24\text{dB}$
Radiated emissions (6GHz ~18GHz)	$\pm 3.24\text{dB}$
Radiated emissions (18GHz ~40GHz)	$\pm 4.08\text{dB}$
Conducted emissions	$\pm 2.00\text{dB}$
Occupied Channel Bandwidth	$\pm 71.333\text{Hz}$
Conducted Output power	$\pm 0.78\text{dB}$
Band Edge Measurements	$\pm 2.00\text{dB}$

Note: This uncertainty represents an expanded uncertainty expressed at approximately the 95% confidence level using a coverage factor of $k=2$.

7 Photographs Of Test Setup

Please refer to Appendix A of this test report.

8 Photographs Of EUT

Please refer to Appendix B of this test report.

Appendix : Test Results

Band	Test Results
n2	Please refer to Appendix C
n5	Please refer to Appendix D
n7	Please refer to Appendix E
n12	Please refer to Appendix F
n25	Please refer to Appendix G
n41	Please refer to Appendix H
n66	Please refer to Appendix I
n71	Please refer to Appendix J

-----End of the report-----