



A D T

FCC TEST REPORT

REPORT NO. : RF110926C28

MODEL NO. : NP220-B (refer to item 3.1 for more details)

FCC ID : Z3M-GNP22

RECEIVED : Sep. 26, 2011

TESTED : Oct. 20 ~ Oct. 31, 2011

ISSUED : Nov. 03, 2011

APPLICANT : Greenwave Reality Pte Ltd

ADDRESS : 41 Science Park Road, #03-01, The Gemini,
Science Park II, Singapore 117610

ISSUED BY : Bureau Veritas Consumer Products Services
(H.K.) Ltd., Taoyuan Branch

LAB ADDRESS : No. 47, 14th Ling, Chia Pau Vil., Lin Kou Dist.,
New Taipei City, Taiwan (R.O.C)

TEST LOCATION : No. 19, Hwa Ya 2nd Rd, Wen Hwa Tsuen, Kwei
Shan Hsiang, Taoyuan Hsien 333, Taiwan, R.O.C.

This test report consists of 40 pages in total. It may be duplicated completely for legal use with the approval of the applicant. It should not be reproduced except in full, without the written approval of our laboratory. The client should not use it to claim product, certification, approval or endorsement by TAF or any government agency. The test results in the report only apply to the tested sample. The test results in this report are traceable to the national or international standards.





A D T

Table of Contents

RELEASE CONTROL RECORD.....	3
1. CERTIFICATION	4
2. SUMMARY OF TEST RESULTS	5
2.1 MEASUREMENT UNCERTAINTY	5
3. GENERAL INFORMATION.....	6
3.1 GENERAL DESCRIPTION OF EUT	6
3.2 DESCRIPTION OF TEST MODES.....	7
3.2.1 CONFIGURATION OF SYSTEM UNDER TEST	7
3.2.2 TEST MODE APPLICABILITY AND TESTED CHANNEL DETAIL.....	8
3.3 GENERAL DESCRIPTION OF APPLIED STANDARDS	9
3.4 DESCRIPTION OF SUPPORT UNITS	10
4. TEST TYPES AND RESULTS	11
4.1 RADIATED EMISSION MEASUREMENT	11
4.1.1 LIMITS OF RADIATED EMISSION MEASUREMENT.....	11
4.1.2 TEST INSTRUMENTS	12
4.1.3 TEST PROCEDURES	13
4.1.4 DEVIATION FROM TEST STANDARD	13
4.1.5 TEST SETUP	14
4.1.6 EUT OPERATING CONDITIONS	14
4.1.7 TEST RESULTS	15
4.2 CONDUCTED EMISSION MEASUREMENT	30
4.2.1 LIMITS OF CONDUCTED EMISSION MEASUREMENT.....	30
4.2.2 TEST INSTRUMENTS	30
4.2.3 TEST PROCEDURES	31
4.2.4 DEVIATION FROM TEST STANDARD	31
4.2.5 TEST SETUP	32
4.2.6 EUT OPERATING CONDITIONS	32
4.2.7 TEST RESULTS	33
4.3 BAND EDGES MEASUREMENT	35
4.3.1 LIMITS OF BAND EDGES MEASUREMENT	35
4.3.2 TEST INSTRUMENTS	35
4.3.3 TEST PROCEDURE	35
4.3.4 DEVIATION FROM TEST STANDARD	35
4.3.5 EUT OPERATING CONDITION	35
4.3.6 TEST RESULTS	36
5. PHOTOGRAPHS OF THE TEST CONFIGURATION.....	38
6. INFORMATION ON THE TESTING LABORATORIES	39
7. APPENDIX A - MODIFICATIONS RECORDERS FOR ENGINEERING CHANGES TO THE EUT BY THE LAB.....	40



A D T

RELEASE CONTROL RECORD

ISSUE NO.	REASON FOR CHANGE	DATE ISSUED
Original release	NA	Nov. 03, 2011



A D T

1. CERTIFICATION

PRODUCT: Power Node

MODEL NO.: NP220-B (refer to item 3.1 for more details)

BRAND: greenWAVE

APPLICANT: Greenwave Reality Pte Ltd

TESTED: Oct. 20 ~ Oct. 31, 2011

TEST SAMPLE: ENGINEERING SAMPLE

STANDARDS: FCC Part 15, Subpart C (Section 15.249)

ANSI C63.4-2003

ANSI C63.10-2009

The above equipment (model: NP220-B) have been tested by **Bureau Veritas Consumer Products Services (H.K.) Ltd., Taoyuan Branch**, and found compliance with the requirement of the above standards. The test record, data evaluation & Equipment Under Test (EUT) configurations represented herein are true and accurate accounts of the measurements of the sample's EMC characteristics under the conditions specified in this report.

PREPARED BY :  , DATE : Nov. 03, 2011
Pettie Chen / Specialist

APPROVED BY :  , DATE : Nov. 03, 2011
Gary Chang / Technical Manager



2. SUMMARY OF TEST RESULTS

The EUT has been tested according to the following specifications:

APPLIED STANDARD: FCC Part 15, Subpart C (Section 15.249)			
STANDARD PARAGRAPH	TEST TYPE	RESULT	REMARK
15.207	Conducted Emission Test	PASS	Meet the requirement of limit. Minimum passing margin is -1.06dB at 0.483MHz.
15.209 15.249 15.249 (d)	Radiated Emission Test Band Edge Measurement Limit: 50dB less than the peak value of fundamental frequency or meet radiated emission limit in section 15.209	PASS	Meet the requirement of limit. Minimum passing margin is -1.3 dB at 908.42MHz.

2.1 MEASUREMENT UNCERTAINTY

Where relevant, the following measurement uncertainty levels have been estimated for tests performed on the EUT as specified in CISPR 16-4-2:

MEASUREMENT	FREQUENCY	UNCERTAINTY
Conducted emissions	9kHz~30MHz	2.44 dB
Radiated emissions	30MHz ~ 200MHz	3.34 dB
	200MHz ~1000MHz	3.35 dB
	1GHz ~ 18GHz	2.26 dB
	18GHz ~ 40GHz	1.94 dB

This uncertainty represents an expanded uncertainty expressed at approximately the 95% confidence level using a coverage factor of k=2.



3. GENERAL INFORMATION

3.1 GENERAL DESCRIPTION OF EUT

EUT	Power Node
MODEL NO.	NP220-B (refer to NOTE for more details)
FCC ID	Z3M-GNP22
POWER SUPPLY	100-240Vac
MODULATION TYPE	2 Frequency Shift Keying (2FSK) (9.6kbpps) 2 Gaussian Frequency Shift Keying (2GFSK) (40kbps/100kbps)
OPERATING FREQUENCY	908.42MHz, 908.4MHz, 916MHz
NUMBER OF CHANNEL	3
ANTENNA TYPE	Dipole antenna with 0.24dBi gain
POWER CORD	1.0m non-shielded cable without core
DATA CABLE	NA
I/O PORT	NA
ACCESSORY DEVICES	NA

NOTE:

1. The following models are electrically identical, different model names are for marketing purpose.

BRAND	MODEL	DIFFERENCE
greenWAVE	NP220-B	Appearance color: White
	NP222-B	Appearance color: Black

2. The above EUT information is declared by the manufacturer and for more detailed features description, please refer to the manufacturer's specifications or User's Manual.

3.2 DESCRIPTION OF TEST MODES

3 channels are provided to this EUT.

CHANNEL	FREQ. (MHz)
1	908.42
2	908.40
3	916.00

3.2.1 CONFIGURATION OF SYSTEM UNDER TEST

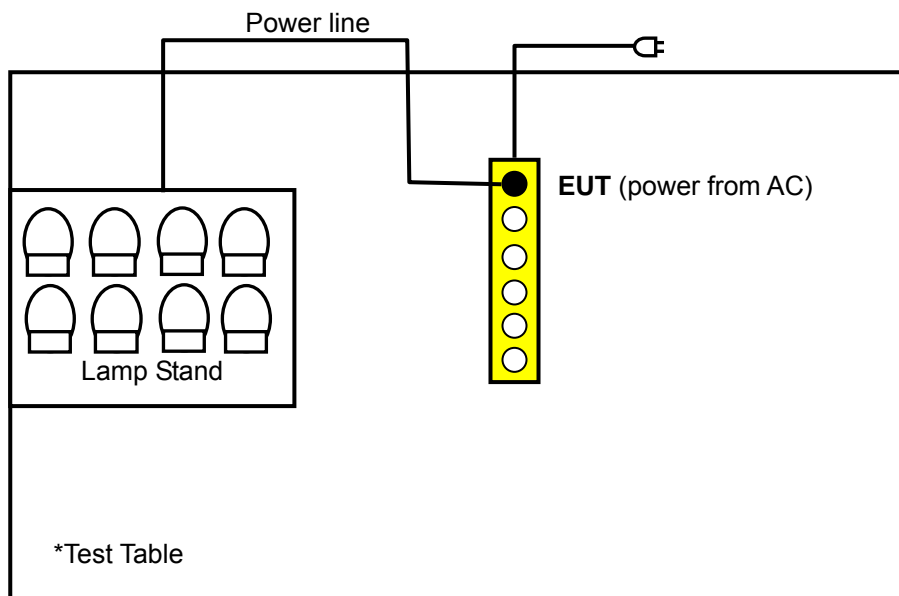



3.2.2 TEST MODE APPLICABILITY AND TESTED CHANNEL DETAIL

EUT CONFIGURE MODE	APPLICABLE TO				DESCRIPTION
	RE≥1G	RE<1G	PLC	BM	
-	√	√	√	√	-

Where **PLC**: Power Line Conducted Emission
RE≥1G: Radiated Emission above 1GHz

RE<1G: Radiated Emission below 1GHz
BM: Bandedge Measurement

RADIATED EMISSION TEST (ABOVE 1 GHz):

- Pre-Scan has been conducted to determine the worst-case mode from all possible combinations between available modulations, XYZ axis and antenna ports (if EUT with antenna diversity architecture).
- Following channel(s) was (were) selected for the final test as listed below.

TESTED CHANNEL	OPERATING FREQUENCY	MODULATION TYPE	AXIS
1	908.42MHz	2FSK	Y
2	908.40MHz	2GFSK	Y
3	916.00MHz	2GFSK	Y

RADIATED EMISSION TEST (BELOW 1 GHz):

- Pre-Scan has been conducted to determine the worst-case mode from all possible combinations between available modulations, XYZ axis and antenna ports (if EUT with antenna diversity architecture).
- Following channel(s) was (were) selected for the final test as listed below.

TESTED CHANNEL	OPERATING FREQUENCY	MODULATION TYPE	AXIS
1	908.42MHz	2FSK	Y
2	908.40MHz	2GFSK	Y
3	916.00MHz	2GFSK	Y

POWER LINE CONDUCTED EMISSION TEST:

- Pre-Scan has been conducted to determine the worst-case mode from all possible combinations between available modulations and antenna ports (if EUT with antenna diversity architecture).
- Following channel(s) was (were) selected for the final test as listed below.

TESTED CHANNEL	OPERATING FREQUENCY	MODULATION TYPE
1	908.42MHz	2FSK

BANDEDGE MEASUREMENT:

- Pre-Scan has been conducted to determine the worst-case mode from all possible combinations between available modulations and antenna ports (if EUT with antenna diversity architecture).
- Following channel(s) was (were) selected for the final test as listed below.

TESTED CHANNEL	OPERATING FREQUENCY	MODULATION TYPE
2	908.40MHz	2GFSK
3	916.00MHz	2GFSK

TEST CONDITION:

APPLICABLE TO	ENVIRONMENTAL CONDITIONS	INPUT POWER	TESTED BY
RE \geq 1G	25deg. C, 65%RH	120Vac, 60Hz	David Huang
RE $<$ 1G	25deg. C, 65%RH	120Vac, 60Hz	Kay Wu
PLC	24deg. C, 64%RH	120Vac, 60Hz	Match Tsui
BM	25deg. C, 65%RH	120Vac, 60Hz	David Huang

3.3 GENERAL DESCRIPTION OF APPLIED STANDARDS

The EUT is a RF Product. According to the specifications of the manufacturer, it must comply with the requirements of the following standards:

FCC Part 15, Subpart C (Section 15.249)

ANSI C63.4-2003

ANSI C63.10-2009

All test items have been performed and recorded as per the above standards.

NOTE: The EUT is also considered as a kind of computer peripheral, because the connection to computer is necessary for typical use. It has been verified to comply with the requirements of FCC Part 15, Subpart B, Class B (DoC). The test report has been issued separately.

3.4 DESCRIPTION OF SUPPORT UNITS

The EUT has been tested as an independent unit together with other necessary accessories or support units. The following support units or accessories were used to form a representative test configuration during the tests.

NO.	PRODUCT	BRAND	MODEL NO.	SERIAL NO.	FCC ID
1	LAMP STAND	NA	NA	NA	NA
2	LIGHT BULB *8	NA	NA	NA	NA

NO.	SIGNAL CABLE DESCRIPTION OF THE ABOVE SUPPORT UNITS
1	NA
2	NA

NOTE: All power cords of the above support units are non shielded (1.8m).

4. TEST TYPES AND RESULTS

4.1 RADIATED EMISSION MEASUREMENT

4.1.1 LIMITS OF RADIATED EMISSION MEASUREMENT

Emissions radiated outside of the specified bands, shall be according to the general radiated limits in 15.209, 15.249 as following:

15.209 Limit		
Frequencies (MHz)	Field strength (microvolts/meter)	Measurement distance (meters)
0.009 ~ 0.490	2400/F(kHz)	300
0.490 ~ 1.705	24000/F(kHz)	30
1.705 ~ 30.0	30	30
30 ~ 88	100	3
88 ~ 216	150	3
216 ~ 960	200	3
Above 960	500	3
15.249 Limit		
Fundamental Frequency	Field Strength of Fundamental (millivolts/meter)	Field Strength of Harmonics (microvolts/meter)
902 ~ 928 MHz	50	500
2400 ~ 2483.5 MHz	50	500
5725 ~ 5875 MHz	50	500
24 ~ 24.25 GHz	250	2500

NOTE:

1. The lower limit shall apply at the transition frequencies.
2. Emission level (dBuV/m) = 20 log Emission level (uV/m).
3. As shown in 15.35(b), for frequencies above 1000MHz, the field strength limits are based on average detector, however, the peak field strength of any emission shall not exceed the maximum permitted average limits, specified above by more than 20dB under any condition of modulation.

4.1.2 TEST INSTRUMENTS

DESCRIPTION & MANUFACTURER	MODEL NO.	SERIAL NO.	DATE OF CALIBRATION	DUE DATE OF CALIBRATION
Test Receiver ROHDE & SCHWARZ	ESIB7	100212	Aug. 02, 2011	Aug. 01, 2012
Spectrum Analyzer ROHDE & SCHWARZ	FSP 40	100041	Jul. 21, 2011	Jul. 20, 2012
BILOG Antenna SCHWARZBECK	VULB9168	9168-160	Apr. 13, 2011	Apr. 12, 2012
HORN Antenna SCHWARZBECK	9120D	209	Aug. 25, 2011	Aug. 24, 2012
HORN Antenna SCHWARZBECK	BBHA 9170	BBHA9170243	Dec. 27, 2010	Dec. 26, 2011
Preamplifier Agilent	8447D	2944A10633	Oct. 29, 2011	Oct. 28, 2012
Preamplifier Agilent	8449B	3008A01964	Oct. 29, 2011	Oct. 28, 2012
RF signal cable HUBER+SUHNNER	SUCOFLEX 104	295014/4	Aug. 19, 2011	Aug. 18, 2012
RF signal cable HUBER+SUHNNER	SUCOFLEX 104	12738/6	Aug. 19, 2011	Aug. 18, 2012
Software ADT.	ADT_Radiated_ V7.6.15.9.2	NA	NA	NA
Antenna Tower inn-co GmbH	MA 4000	013303	NA	NA
Antenna Tower Controller inn-co GmbH	CO2000	017303	NA	NA
Turn Table ADT.	TT100.	TT93021703	NA	NA
Turn Table Controller ADT.	SC100.	SC93021703	NA	NA

- NOTE:**
1. The calibration interval of the above test instruments is 12 months and the calibrations are traceable to NML/ROC and NIST/USA.
 2. The test was performed in HwaYa Chamber 3.
 3. The horn antenna and HP preamplifier (model: 8449B) are used only for the measurement of emission frequency above 1GHz if tested.
 4. The FCC Site Registration No. is 988962.
 5. The IC Site Registration No. is IC 7450F-3.

4.1.3 TEST PROCEDURES

- a. The EUT was placed on the top of a rotating table 0.8 meters above the ground at a 3 meter semi-anechoic chamber. The table was rotated 360 degrees to determine the position of the highest radiation.
- b. The EUT was set 3 meters away from the interference-receiving antenna, which was mounted on the top of a variable-height antenna tower.
- c. The antenna is a broadband antenna, and its height is varied from one meter to four meters above the ground to determine the maximum value of the field strength. Both horizontal and vertical polarizations of the antenna are set to make the measurement.
- d. For each suspected emission, the EUT was arranged to its worst case and then the antenna was tuned to heights from 1 meter to 4 meters and the rotatable table was turned from 0 degrees to 360 degrees to find the maximum reading.
- e. The test-receiver system was set to Peak Detect Function and Specified Bandwidth with Maximum Hold Mode.
- f. If the emission level of the EUT in peak mode was lower than the limit specified, then testing could be stopped and the peak values of the EUT would be reported. Otherwise the emissions would be re-tested one by one using peak, quasi-peak or average method as specified and then reported in a data sheet.

NOTE:

1. The resolution bandwidth and video bandwidth of test receiver/spectrum analyzer is 120kHz for Quasi-peak detection at frequency below 1GHz.
2. The resolution bandwidth of test receiver/spectrum analyzer is 1MHz and video bandwidth is 3MHz for Peak detection at frequency above 1GHz.
3. All modes of operation were investigated and the worst-case emissions are reported.

4.1.4 DEVIATION FROM TEST STANDARD

No deviation.

4.1.5 TEST SETUP

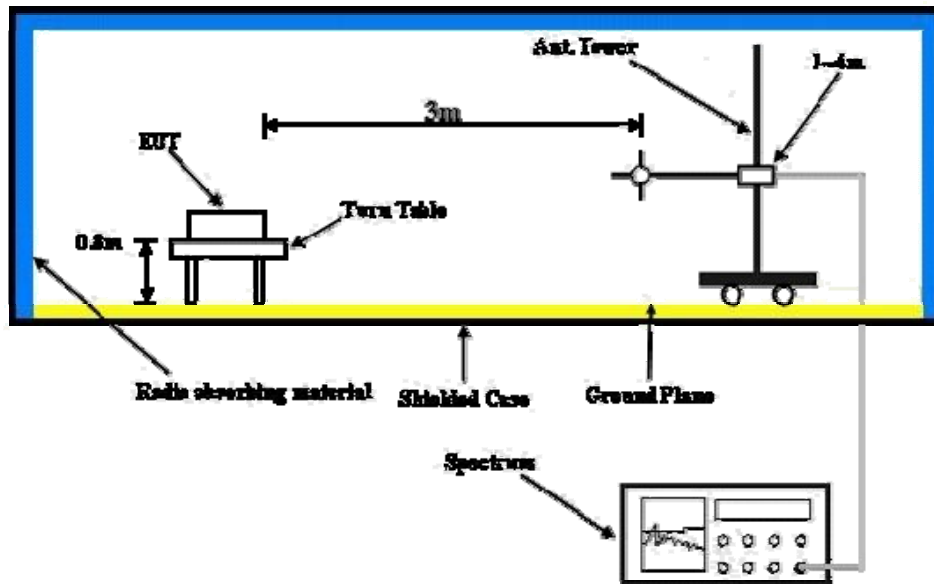

For the actual test configuration, please refer to the attached file (Test Setup Photo).

4.1.6 EUT OPERATING CONDITIONS

- a. Set the EUT under full load condition and placed them on a testing table.
- b. Set the transmitter part of EUT under transmission condition continuously at specific channel frequency.
- c. The necessary accessories enable the EUT in full functions.



4.1.7 TEST RESULTS

For 908.42 MHz

EUT TEST CONDITION		MEASUREMENT DETAIL	
CHANNEL	Channel 1 (908.42MHz)	FREQUENCY RANGE	Below 1000MHz
INPUT POWER	120Vac, 60 Hz	DETECTOR FUNCTION	Quasi-Peak
ENVIRONMENTAL CONDITIONS	25deg. C, 65%RH	TESTED BY	David Huang

ANTENNA POLARITY & TEST DISTANCE: HORIZONTAL AT 3 M								
NO.	FREQ. (MHz)	EMISSION LEVEL (dBuV/m)	LIMIT (dBuV/m)	MARGIN (dB)	ANTENNA HEIGHT (m)	TABLE ANGLE (Degree)	RAW VALUE (dBuV)	CORRECTION FACTOR (dB/m)
1	*908.42	88.5 QP	94.0	-5.5	1.00 H	231	61.5	27.0

ANTENNA POLARITY & TEST DISTANCE: VERTICAL AT 3 M								
NO.	FREQ. (MHz)	EMISSION LEVEL (dBuV/m)	LIMIT (dBuV/m)	MARGIN (dB)	ANTENNA HEIGHT (m)	TABLE ANGLE (Degree)	RAW VALUE (dBuV)	CORRECTION FACTOR (dB/m)
1	*908.42	92.7 QP	94.0	-1.3	1.00 V	74	65.7	27.0

- REMARKS:**
1. Emission level (dBuV/m) = Raw Value (dBuV) + Correction Factor (dB/m).
 2. Correction Factor (dB/m) = Antenna Factor (dB/m) + Cable Factor (dB).
 3. The other emission levels were very low against the limit.
 4. Margin value = Emission level – Limit value.
 5. “ * “ : Fundamental frequency
 6. The average value of fundamental frequency is: Average = Peak value + 20log(Duty cycle) Where the duty factor is calculated from following formula:
 $20 \log (\text{Duty cycle}) = 20 \log (43 \text{ ms} / 100 \text{ ms}) = -7.3 \text{ dB}$

Please see page 19 for plotted duty.



ABOVE 1GHz DATA

EUT TEST CONDITION		MEASUREMENT DETAIL	
CHANNEL	Channel 1 (908.42MHz)	FREQUENCY RANGE	1 ~ 25GHz
INPUT POWER	120Vac, 60Hz	DETECTOR FUNCTION	Peak (PK) Average (AV)
ENVIRONMENTAL CONDITIONS	25deg. C, 65%RH	TESTED BY	David Huang

ANTENNA POLARITY & TEST DISTANCE: HORIZONTAL AT 3 M								
NO.	FREQ. (MHz)	EMISSION LEVEL (dBuV/m)	LIMIT (dBuV/m)	MARGIN (dB)	ANTENNA HEIGHT (m)	TABLE ANGLE (Degree)	RAW VALUE (dBuV)	CORRECTION FACTOR (dB/m)
1	1816.84	40.5 PK	74.0	-33.5	1.00 H	74	11.20	29.30
2	1816.84	33.2 AV	54.0	-20.8	1.00 H	74	3.90	29.30
3	2725.26	52.0 PK	74.0	-22.0	1.02 H	70	19.90	32.10
4	2725.26	44.7 AV	54.0	-9.3	1.02 H	70	12.60	32.10
5	3633.68	44.9 PK	74.0	-29.1	1.00 H	30	11.00	33.90
6	3633.68	37.6 AV	54.0	-16.4	1.00 H	30	3.70	33.90
7	4542.10	47.7 PK	74.0	-26.3	1.73 H	30	11.50	36.20
8	4542.10	40.3 AV	54.0	-13.7	1.73 H	30	4.10	36.20
9	5450.52	45.6 PK	74.0	-28.4	1.00 H	262	7.70	37.90
10	5450.52	38.3 AV	54.0	-15.7	1.00 H	262	0.40	37.90
11	6358.94	49.8 PK	74.0	-24.2	1.27 H	115	9.60	40.20
12	6358.94	42.5 AV	54.0	-11.5	1.27 H	115	2.30	40.20
13	8175.78	54.8 PK	74.0	-19.2	1.00 H	177	10.40	44.40
14	8175.78	47.5 AV	54.0	-6.5	1.00 H	177	3.10	44.40

- REMARKS:**
1. Emission level (dBuV/m) = Raw Value (dBuV) + Correction Factor (dB/m).
 2. Correction Factor (dB/m) = Antenna Factor (dB/m) + Cable Factor (dB).
 3. The other emission levels were very low against the limit.
 4. Margin value = Emission level – Limit value.
 5. The average value of fundamental frequency is: Average = Peak value + 20log(Duty cycle) Where the duty factor is calculated from following formula:
20 log (Duty cycle) = 20 log (43 ms / 100 ms) = -7.3 dB

Please see page 19 for plotted duty.



A D T

EUT TEST CONDITION		MEASUREMENT DETAIL	
CHANNEL	Channel 1 (908.42MHz)	FREQUENCY RANGE	1 ~ 25GHz
INPUT POWER	120Vac, 60Hz	DETECTOR FUNCTION	Peak (PK) Average (AV)
ENVIRONMENTAL CONDITIONS	25deg. C, 65%RH	TESTED BY	David Huang

ANTENNA POLARITY & TEST DISTANCE: VERTICAL AT 3 M								
NO.	FREQ. (MHz)	EMISSION LEVEL (dBuV/m)	LIMIT (dBuV/m)	MARGIN (dB)	ANTENNA HEIGHT (m)	TABLE ANGLE (Degree)	RAW VALUE (dBuV)	CORRECTION FACTOR (dB/m)
1	1816.84	40.3 PK	74.0	-33.7	1.00 V	87	11.00	29.30
2	1816.84	33.0 AV	54.0	-21.0	1.00 V	87	3.70	29.30
3	2725.26	53.8 PK	74.0	-20.2	1.00 V	37	21.70	32.10
4	2725.26	46.5 AV	54.0	-7.5	1.00 V	37	14.40	32.10
5	3633.68	45.9 PK	74.0	-28.1	1.09 V	26	12.00	33.90
6	3633.68	38.6 AV	54.0	-15.4	1.09 V	26	4.70	33.90
7	4542.10	49.5 PK	74.0	-24.5	1.56 V	23	13.30	36.20
8	4542.10	42.2 AV	54.0	-11.8	1.56 V	23	6.00	36.20
9	5450.52	47.2 PK	74.0	-26.8	1.10 V	213	9.30	37.90
10	5450.52	39.9 AV	54.0	-14.1	1.10 V	213	2.00	37.90
11	6358.94	51.8 PK	74.0	-22.2	1.16 V	60	11.60	40.20
12	6358.94	44.5 AV	54.0	-9.5	1.16 V	60	4.30	40.20
13	8175.78	59.3 PK	74.0	-14.7	1.37 V	104	14.90	44.40
14	8175.78	52.0 AV	54.0	-2.0	1.37 V	104	7.60	44.40

- REMARKS:**
1. Emission level (dBuV/m) = Raw Value (dBuV) + Correction Factor (dB/m).
 2. Correction Factor (dB/m) = Antenna Factor (dB/m) + Cable Factor (dB).
 3. The other emission levels were very low against the limit.
 4. Margin value = Emission level – Limit value.
 5. The average value of fundamental frequency is: Average = Peak value + 20log(Duty cycle) Where the duty factor is calculated from following formula:
 $20 \log (\text{Duty cycle}) = 20 \log (43 \text{ ms} / 100 \text{ ms}) = -7.3 \text{ dB}$

Please see page 19 for plotted duty.



A D T

BELOW 1GHz WORST-CASE DATA

EUT TEST CONDITION		MEASUREMENT DETAIL	
CHANNEL	Channel 1 (908.42MHz)	FREQUENCY RANGE	Below 1000MHz
INPUT POWER	120Vac, 60Hz	DETECTOR FUNCTION	Quasi-Peak
ENVIRONMENTAL CONDITIONS	25deg. C, 65%RH	TESTED BY	Kay Wu

ANTENNA POLARITY & TEST DISTANCE: HORIZONTAL AT 3 M								
NO.	FREQ. (MHz)	EMISSION LEVEL (dBuV/m)	LIMIT (dBuV/m)	MARGIN (dB)	ANTENNA HEIGHT (m)	TABLE ANGLE (Degree)	RAW VALUE (dBuV)	CORRECTION FACTOR (dB/m)
1	63.05	25.9 QP	40.0	-14.1	3.50 H	109	13.10	12.80
2	70.82	24.9 QP	40.0	-15.1	4.00 H	103	13.10	11.80
3	146.63	28.7 QP	43.5	-14.8	3.50 H	256	14.30	14.40
4	162.18	31.3 QP	43.5	-12.2	1.50 H	277	16.80	14.50
5	432.38	28.6 QP	46.0	-17.4	2.00 H	67	10.30	18.30
6	902.81	25.9 QP	46.0	-20.1	2.00 H	82	-1.10	27.00
ANTENNA POLARITY & TEST DISTANCE: VERTICAL AT 3 M								
NO.	FREQ. (MHz)	EMISSION LEVEL (dBuV/m)	LIMIT (dBuV/m)	MARGIN (dB)	ANTENNA HEIGHT (m)	TABLE ANGLE (Degree)	RAW VALUE (dBuV)	CORRECTION FACTOR (dB/m)
1	57.21	25.5 QP	40.0	-14.5	1.00 V	193	12.00	13.50
2	162.18	25.0 QP	43.5	-18.5	1.50 V	340	10.50	14.50
3	366.29	23.4 QP	46.0	-22.6	1.50 V	31	6.80	16.60
4	432.38	26.4 QP	46.0	-19.6	1.50 V	337	8.10	18.30
5	663.71	28.8 QP	46.0	-17.2	1.00 V	262	5.30	23.50
6	902.81	25.3 QP	46.0	-20.7	1.00 V	82	-1.70	27.00

- REMARKS:**
1. Emission level (dBuV/m) = Raw Value (dBuV) + Correction Factor (dB/m).
 2. Correction Factor (dB/m) = Antenna Factor (dB/m) + Cable Factor (dB).
 3. The other emission levels were very low against the limit.
 4. Margin value = Emission level – Limit value.



A D T

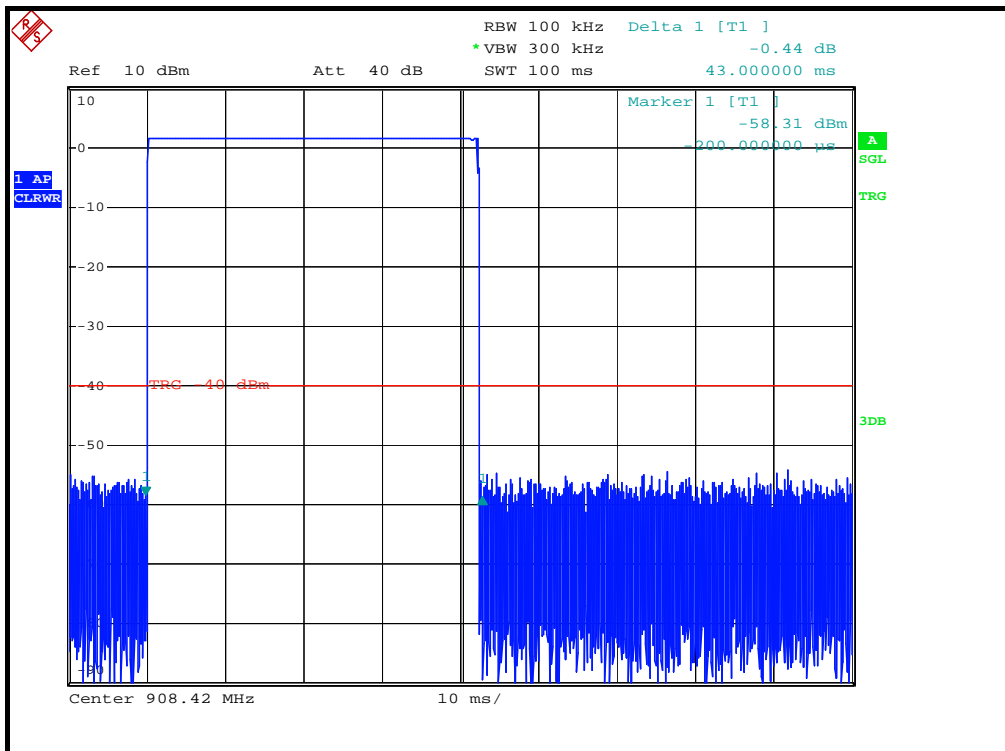

$$20 \log (\text{Duty cycle}) = 20 \log (43\text{ms} / 100 \text{ms}) = -7.3\text{dB}$$



For 908.40 MHz

EUT TEST CONDITION		MEASUREMENT DETAIL	
CHANNEL	Channel 2 (908.40MHz)	FREQUENCY RANGE	Below 1000MHz
INPUT POWER	120Vac, 60 Hz	DETECTOR FUNCTION	Quasi-Peak
ENVIRONMENTAL CONDITIONS	25deg. C, 65%RH	TESTED BY	David Huang

ANTENNA POLARITY & TEST DISTANCE: HORIZONTAL AT 3 M								
NO.	FREQ. (MHz)	EMISSION LEVEL (dBuV/m)	LIMIT (dBuV/m)	MARGIN (dB)	ANTENNA HEIGHT (m)	TABLE ANGLE (Degree)	RAW VALUE (dBuV)	CORRECTION FACTOR (dB/m)
1	*908.40	79.9 QP	94.0	-14.1	1.57 H	48	52.9	27.0
ANTENNA POLARITY & TEST DISTANCE: VERTICAL AT 3 M								
NO.	FREQ. (MHz)	EMISSION LEVEL (dBuV/m)	LIMIT (dBuV/m)	MARGIN (dB)	ANTENNA HEIGHT (m)	TABLE ANGLE (Degree)	RAW VALUE (dBuV)	CORRECTION FACTOR (dB/m)
1	*908.40	84.4 QP	94.0	-9.6	1.05 V	198	57.4	27.0

- REMARKS:**
1. Emission level (dBuV/m) = Raw Value (dBuV) + Correction Factor (dB/m).
 2. Correction Factor (dB/m) = Antenna Factor (dB/m) + Cable Factor (dB).
 3. The other emission levels were very low against the limit.
 4. Margin value = Emission level – Limit value.
 5. “ * “ : Fundamental frequency
 6. The average value of fundamental frequency is: Average = Peak value + 20log(Duty cycle) Where the duty factor is calculated from following formula:
 $20 \log (\text{Duty cycle}) = 20 \log (14.88 \text{ ms} / 100 \text{ ms}) = -16.5 \text{ dB}$

Please see page 24 for plotted duty.



A D T

ABOVE 1GHz DATA

EUT TEST CONDITION		MEASUREMENT DETAIL	
CHANNEL	Channel 2 (908.40MHz)	FREQUENCY RANGE	1 ~ 25GHz
INPUT POWER	120Vac, 60Hz	DETECTOR FUNCTION	Peak (PK) Average (AV)
ENVIRONMENTAL CONDITIONS	25deg. C, 65%RH	TESTED BY	David Huang

ANTENNA POLARITY & TEST DISTANCE: HORIZONTAL AT 3 M								
NO.	FREQ. (MHz)	EMISSION LEVEL (dBuV/m)	LIMIT (dBuV/m)	MARGIN (dB)	ANTENNA HEIGHT (m)	TABLE ANGLE (Degree)	RAW VALUE (dBuV)	CORRECTION FACTOR (dB/m)
1	2725.20	57.9 PK	74.0	-16.1	1.06 H	252	25.80	32.10
2	2725.20	41.4 AV	54.0	-12.6	1.06 H	252	9.30	32.10
3	3633.60	45.8 PK	74.0	-28.2	1.13 H	210	11.90	33.90
4	3633.60	29.3 AV	54.0	-24.7	1.13 H	210	-4.60	33.90
5	4542.00	59.2 PK	74.0	-14.8	1.60 H	99	23.00	36.20
6	4542.00	42.7 AV	54.0	-11.3	1.60 H	99	6.50	36.20
7	6358.80	51.4 PK	74.0	-22.6	1.28 H	176	11.20	40.20
8	6358.80	34.9 AV	54.0	-19.1	1.28 H	176	-5.30	40.20
9	8175.00	55.1 PK	74.0	-18.9	1.00 H	0	10.70	44.40
10	8175.00	38.6 AV	54.0	-15.4	1.00 H	0	-5.80	44.40

- REMARKS:**
1. Emission level (dBuV/m) = Raw Value (dBuV) + Correction Factor (dB/m).
 2. Correction Factor (dB/m) = Antenna Factor (dB/m) + Cable Factor (dB).
 3. The other emission levels were very low against the limit.
 4. Margin value = Emission level – Limit value.
 5. The average value of fundamental frequency is: Average = Peak value + 20log(Duty cycle) Where the duty factor is calculated from following formula:
 $20 \log (\text{Duty cycle}) = 20 \log (14.88 \text{ ms} / 100 \text{ ms}) = -16.5 \text{ dB}$

Please see page 24 for plotted duty.



A D T

EUT TEST CONDITION		MEASUREMENT DETAIL	
CHANNEL	Channel 2 (908.40MHz)	FREQUENCY RANGE	1 ~ 25GHz
INPUT POWER	120Vac, 60Hz	DETECTOR FUNCTION	Peak (PK) Average (AV)
ENVIRONMENTAL CONDITIONS	25deg. C, 65%RH	TESTED BY	David Huang

ANTENNA POLARITY & TEST DISTANCE: VERTICAL AT 3 M								
NO.	FREQ. (MHz)	EMISSION LEVEL (dBuV/m)	LIMIT (dBuV/m)	MARGIN (dB)	ANTENNA HEIGHT (m)	TABLE ANGLE (Degree)	RAW VALUE (dBuV)	CORRECTION FACTOR (dB/m)
1	2725.20	56.4 PK	74.0	-17.6	1.37 V	112	24.30	32.10
2	2725.20	39.9 AV	54.0	-14.1	1.37 V	112	7.80	32.10
3	3633.60	44.5 PK	74.0	-29.5	1.06 V	135	10.60	33.90
4	3633.60	28.0 AV	54.0	-26.0	1.06 V	135	-5.90	33.90
5	4542.00	65.2 PK	74.0	-8.8	1.12 V	199	29.00	36.20
6	4542.00	48.7 AV	54.0	-5.3	1.12 V	199	12.50	36.20
7	5450.40	46.9 PK	74.0	-27.1	1.00 V	194	9.00	37.90
8	5450.40	30.4 AV	54.0	-23.6	1.00 V	194	-7.50	37.90
9	6358.00	53.5 PK	74.0	-20.5	1.08 V	196	13.30	40.20
10	6358.00	37.0 AV	54.0	-17.0	1.08 V	196	-3.20	40.20
11	8175.60	56.9 PK	74.0	-17.1	1.00 V	192	12.50	44.40
12	8175.60	40.4 AV	54.0	-13.6	1.00 V	192	-4.00	44.40

- REMARKS:**
1. Emission level (dBuV/m) = Raw Value (dBuV) + Correction Factor (dB/m).
 2. Correction Factor (dB/m) = Antenna Factor (dB/m) + Cable Factor (dB).
 3. The other emission levels were very low against the limit.
 4. Margin value = Emission level – Limit value.
 5. The average value of fundamental frequency is: Average = Peak value + 20log(Duty cycle) Where the duty factor is calculated from following formula:
20 log (Duty cycle) = 20 log (14.88 ms / 100 ms) = -16.5 dB

Please see page 24 for plotted duty.



A D T

BELOW 1GHZ WORST-CASE DATA

EUT TEST CONDITION		MEASUREMENT DETAIL	
CHANNEL	Channel 2 (908.40MHz)	FREQUENCY RANGE	Below 1000MHz
INPUT POWER (SYSTEM)	120Vac, 60Hz	DETECTOR FUNCTION	Quasi-Peak
ENVIRONMENTAL CONDITIONS	25deg. C, 65%RH	TESTED BY	Kay Wu

ANTENNA POLARITY & TEST DISTANCE: HORIZONTAL AT 3 M								
NO.	FREQ. (MHz)	EMISSION LEVEL (dBuV/m)	LIMIT (dBuV/m)	MARGIN (dB)	ANTENNA HEIGHT (m)	TABLE ANGLE (Degree)	RAW VALUE (dBuV)	CORRECTION FACTOR (dB/m)
1	63.05	25.7 QP	40.0	-14.3	3.50 H	109	12.90	12.80
2	70.82	25.3 QP	40.0	-14.7	4.00 H	88	13.50	11.80
3	162.18	31.4 QP	43.5	-12.1	1.50 H	289	16.90	14.50
4	335.19	28.3 QP	46.0	-17.7	1.00 H	136	12.50	15.80
5	432.38	27.5 QP	46.0	-18.5	1.50 H	88	9.20	18.30
6	902.81	34.6 QP	46.0	-11.4	1.50 H	49	7.60	27.00
ANTENNA POLARITY & TEST DISTANCE: VERTICAL AT 3 M								
NO.	FREQ. (MHz)	EMISSION LEVEL (dBuV/m)	LIMIT (dBuV/m)	MARGIN (dB)	ANTENNA HEIGHT (m)	TABLE ANGLE (Degree)	RAW VALUE (dBuV)	CORRECTION FACTOR (dB/m)
1	57.21	25.4 QP	40.0	-14.6	1.00 V	229	11.90	13.50
2	63.05	27.9 QP	40.0	-12.1	1.00 V	31	15.10	12.80
3	70.82	25.7 QP	40.0	-14.3	2.50 V	205	13.90	11.80
4	162.18	25.0 QP	43.5	-18.5	1.00 V	211	10.50	14.50
5	432.38	27.4 QP	46.0	-18.6	1.00 V	10	9.10	18.30
6	902.81	29.8 QP	46.0	-16.2	1.00 V	208	2.80	27.00

- REMARKS:**
1. Emission level (dBuV/m) = Raw Value (dBuV) + Correction Factor (dB/m).
 2. Correction Factor (dB/m) = Antenna Factor (dB/m) + Cable Factor (dB).
 3. The other emission levels were very low against the limit.
 4. Margin value = Emission level – Limit value.



A D T

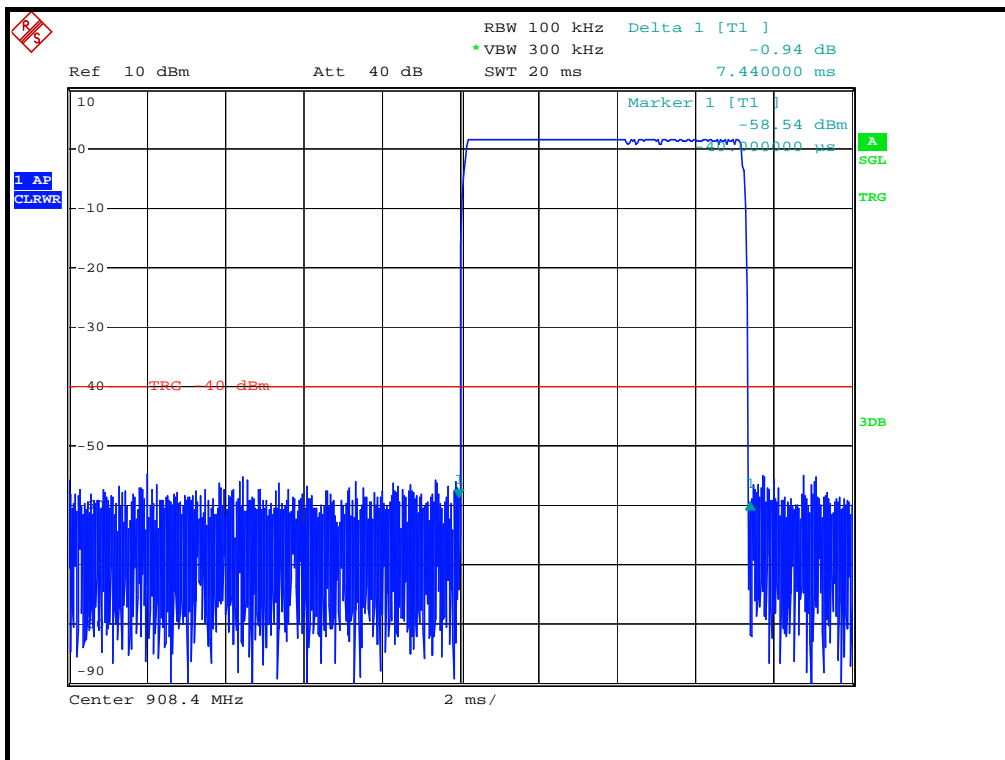
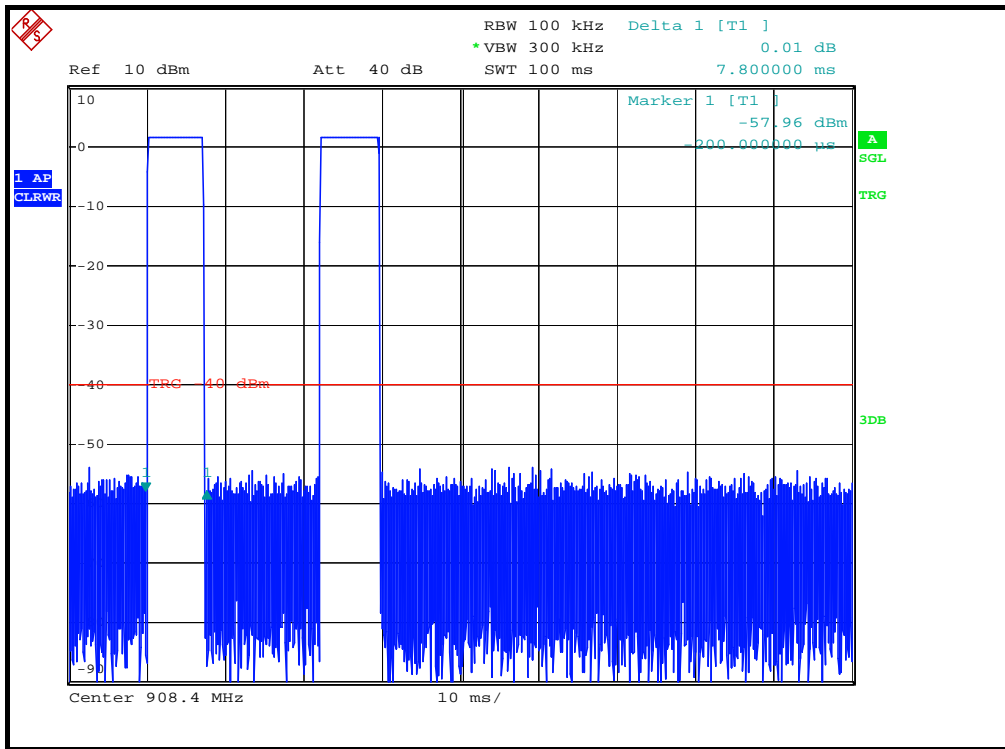

$$20 \log (\text{Duty cycle}) = 20 \log [(7.44 + 7.44) \text{ ms} / 100 \text{ ms}] = -16.5 \text{ dB}$$



For 916.00 MHz

EUT TEST CONDITION		MEASUREMENT DETAIL	
CHANNEL	Channel 3 (916.00MHz)	FREQUENCY RANGE	Below 1000MHz
INPUT POWER	120Vac, 60 Hz	DETECTOR FUNCTION	Quasi-Peak
ENVIRONMENTAL CONDITIONS	25deg. C, 65%RH	TESTED BY	David Huang

ANTENNA POLARITY & TEST DISTANCE: HORIZONTAL AT 3 M								
NO.	FREQ. (MHz)	EMISSION LEVEL (dBuV/m)	LIMIT (dBuV/m)	MARGIN (dB)	ANTENNA HEIGHT (m)	TABLE ANGLE (Degree)	RAW VALUE (dBuV)	CORRECTION FACTOR (dB/m)
1	*916.00	77.6 QP	94.0	-16.4	1.46 H	47	50.5	27.1
ANTENNA POLARITY & TEST DISTANCE: VERTICAL AT 3 M								
NO.	FREQ. (MHz)	EMISSION LEVEL (dBuV/m)	LIMIT (dBuV/m)	MARGIN (dB)	ANTENNA HEIGHT (m)	TABLE ANGLE (Degree)	RAW VALUE (dBuV)	CORRECTION FACTOR (dB/m)
1	*916.00	81.6 QP	94.0	-12.4	1.06 V	196	54.5	27.1

- REMARKS:**
1. Emission level (dBuV/m) = Raw Value (dBuV) + Correction Factor (dB/m).
 2. Correction Factor (dB/m) = Antenna Factor (dB/m) + Cable Factor (dB).
 3. The other emission levels were very low against the limit.
 4. Margin value = Emission level – Limit value.
 5. “ * “ : Fundamental frequency
 6. The average value of fundamental frequency is: Average = Peak value + 20log(Duty cycle) Where the duty factor is calculated from following formula:
 $20 \log (\text{Duty cycle}) = 20 \log (10.24 \text{ ms} / 100 \text{ ms}) = -19.8 \text{ dB}$

Please see page 29 for plotted duty.



ABOVE 1GHz DATA

EUT TEST CONDITION		MEASUREMENT DETAIL	
CHANNEL	Channel 3 (916.00MHz)	FREQUENCY RANGE	1 ~ 25GHz
INPUT POWER	120Vac, 60Hz	DETECTOR FUNCTION	Peak (PK) Average (AV)
ENVIRONMENTAL CONDITIONS	25deg. C, 65%RH	TESTED BY	David Huang

ANTENNA POLARITY & TEST DISTANCE: HORIZONTAL AT 3 M								
NO.	FREQ. (MHz)	EMISSION LEVEL (dBuV/m)	LIMIT (dBuV/m)	MARGIN (dB)	ANTENNA HEIGHT (m)	TABLE ANGLE (Degree)	RAW VALUE (dBuV)	CORRECTION FACTOR (dB/m)
1	2748.00	58.4 PK	74.0	-15.6	1.05 H	252	26.20	32.20
2	2748.00	38.6 AV	54.0	-15.4	1.05 H	252	6.40	32.20
3	4580.00	58.5 PK	74.0	-15.5	1.00 H	189	22.20	36.30
4	4580.00	38.7 AV	54.0	-15.3	1.00 H	189	2.40	36.30
5	5496.00	45.5 PK	74.0	-28.5	1.87 H	230	7.50	38.00
6	5496.00	25.7 AV	54.0	-28.3	1.87 H	230	-12.30	38.00
7	6412.00	49.6 PK	74.0	-24.4	1.00 H	194	9.20	40.40
8	6412.00	29.8 AV	54.0	-24.2	1.00 H	194	-10.60	40.40
9	8244.00	54.3 PK	74.0	-19.7	1.00 H	0	9.80	44.50
10	8244.00	34.5 AV	54.0	-19.5	1.00 H	0	-10.00	44.50

- REMARKS:**
1. Emission level (dBuV/m) = Raw Value (dBuV) + Correction Factor (dB/m).
 2. Correction Factor (dB/m) = Antenna Factor (dB/m) + Cable Factor (dB).
 3. The other emission levels were very low against the limit.
 4. Margin value = Emission level – Limit value.
 5. The average value of fundamental frequency is: Average = Peak value + 20log(Duty cycle) Where the duty factor is calculated from following formula:
 $20 \log (\text{Duty cycle}) = 20 \log (10.24 \text{ ms} / 100 \text{ ms}) = -19.8 \text{ dB}$

Please see page 29 for plotted duty.



A D T

EUT TEST CONDITION		MEASUREMENT DETAIL	
CHANNEL	Channel 3 (916.00MHz)	FREQUENCY RANGE	1 ~ 25GHz
INPUT POWER	120Vac, 60Hz	DETECTOR FUNCTION	Peak (PK) Average (AV)
ENVIRONMENTAL CONDITIONS	25deg. C, 65%RH	TESTED BY	David Huang

ANTENNA POLARITY & TEST DISTANCE: VERTICAL AT 3 M								
NO.	FREQ. (MHz)	EMISSION LEVEL (dBuV/m)	LIMIT (dBuV/m)	MARGIN (dB)	ANTENNA HEIGHT (m)	TABLE ANGLE (Degree)	RAW VALUE (dBuV)	CORRECTION FACTOR (dB/m)
1	2748.00	55.4 PK	74.0	-18.6	1.10 V	102	23.20	32.20
2	2748.00	35.6 AV	54.0	-18.4	1.10 V	102	3.40	32.20
3	4580.00	65.1 PK	74.0	-8.9	1.11 V	207	28.80	36.30
4	4580.00	45.3 AV	54.0	-8.7	1.11 V	207	9.00	36.30
5	5496.00	48.1 PK	74.0	-25.9	1.00 V	193	10.10	38.00
6	5496.00	28.3 AV	54.0	-25.7	1.00 V	193	-9.70	38.00
7	6412.00	52.3 PK	74.0	-21.7	1.26 V	193	11.90	40.40
8	6412.00	32.5 AV	54.0	-21.5	1.26 V	193	-7.90	40.40
9	8244.00	55.6 PK	74.0	-18.4	1.00 V	201	11.10	44.50
10	8244.00	35.8 AV	54.0	-18.2	1.00 V	201	-8.70	44.50

- REMARKS:**
1. Emission level (dBuV/m) = Raw Value (dBuV) + Correction Factor (dB/m).
 2. Correction Factor (dB/m) = Antenna Factor (dB/m) + Cable Factor (dB).
 3. The other emission levels were very low against the limit.
 4. Margin value = Emission level – Limit value.
 5. The average value of fundamental frequency is: Average = Peak value + 20log(Duty cycle) Where the duty factor is calculated from following formula:
 $20 \log (\text{Duty cycle}) = 20 \log (10.24 \text{ ms} / 100 \text{ ms}) = -19.8 \text{ dB}$

Please see page 29 for plotted duty.



A D T

BELOW 1GHZ WORST-CASE DATA

EUT TEST CONDITION		MEASUREMENT DETAIL	
CHANNEL	Channel 3 (916.00MHz)	FREQUENCY RANGE	Below 1000MHz
INPUT POWER	120Vac, 60Hz	DETECTOR FUNCTION	Quasi-Peak
ENVIRONMENTAL CONDITIONS	25deg. C, 65%RH	TESTED BY	Kay Wu

ANTENNA POLARITY & TEST DISTANCE: HORIZONTAL AT 3 M								
NO.	FREQ. (MHz)	EMISSION LEVEL (dBuV/m)	LIMIT (dBuV/m)	MARGIN (dB)	ANTENNA HEIGHT (m)	TABLE ANGLE (Degree)	RAW VALUE (dBuV)	CORRECTION FACTOR (dB/m)
1	63.05	26.0 QP	40.0	-14.0	3.50 H	91	13.20	12.80
2	70.82	25.6 QP	40.0	-14.4	4.00 H	112	13.80	11.80
3	162.18	31.2 QP	43.5	-12.3	1.50 H	283	16.70	14.50
4	364.35	25.0 QP	46.0	-21.0	1.00 H	142	8.50	16.50
5	432.38	28.0 QP	46.0	-18.0	2.00 H	79	9.70	18.30
6	928.08	29.5 QP	46.0	-16.5	1.00 H	10	2.20	27.30
ANTENNA POLARITY & TEST DISTANCE: VERTICAL AT 3 M								
NO.	FREQ. (MHz)	EMISSION LEVEL (dBuV/m)	LIMIT (dBuV/m)	MARGIN (dB)	ANTENNA HEIGHT (m)	TABLE ANGLE (Degree)	RAW VALUE (dBuV)	CORRECTION FACTOR (dB/m)
1	63.05	27.3 QP	40.0	-12.7	1.00 V	181	14.50	12.80
2	146.63	23.8 QP	43.5	-19.7	1.50 V	322	9.40	14.40
3	162.18	24.8 QP	43.5	-18.7	1.00 V	46	10.30	14.50
4	364.35	24.4 QP	46.0	-21.6	1.50 V	37	7.90	16.50
5	432.38	26.4 QP	46.0	-19.6	1.50 V	313	8.10	18.30
6	928.08	26.5 QP	46.0	-19.5	4.00 V	166	-0.80	27.30

- REMARKS:**
1. Emission level (dBuV/m) = Raw Value (dBuV) + Correction Factor (dB/m).
 2. Correction Factor (dB/m) = Antenna Factor (dB/m) + Cable Factor (dB).
 3. The other emission levels were very low against the limit.
 4. Margin value = Emission level – Limit value.

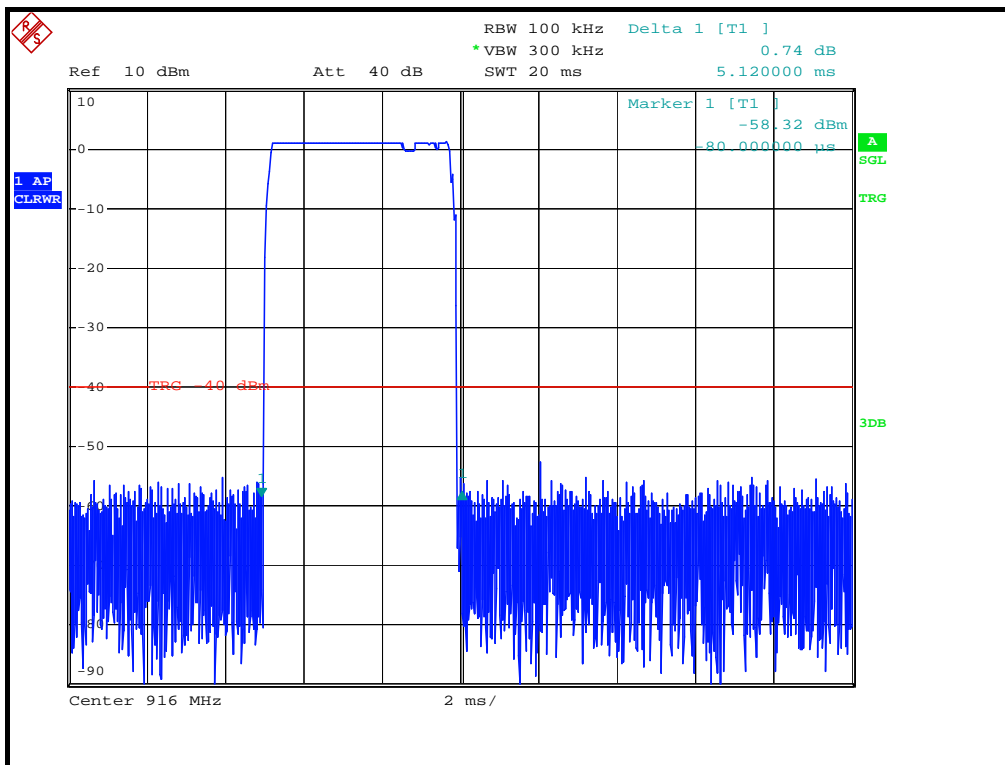
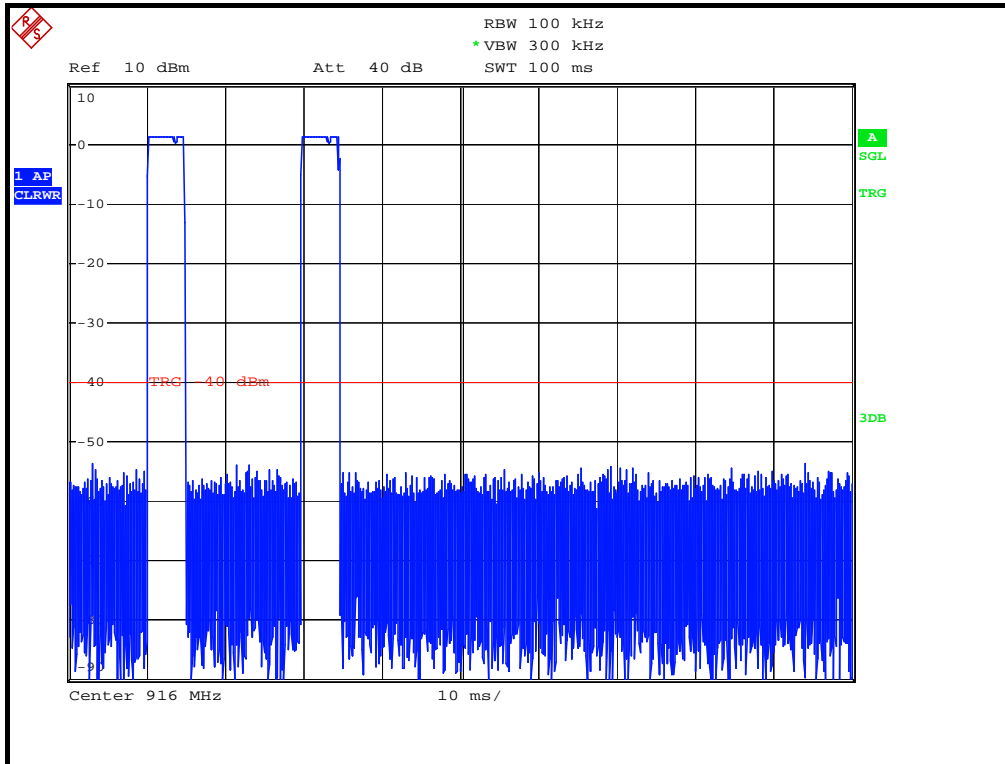

$$20 \log (\text{Duty cycle}) = 20 \log [(5.12 + 5.12) \text{ ms} / 100 \text{ ms}] = -19.8 \text{ dB}$$

4.2 CONDUCTED EMISSION MEASUREMENT

4.2.1 LIMITS OF CONDUCTED EMISSION MEASUREMENT

FREQUENCY OF EMISSION (MHz)	CONDUCTED LIMIT (dB μ V)	
	Quasi-peak	Average
0.15-0.5	66 to 56	56 to 46
0.5-5	56	46
5-30	60	50

- NOTE:**
1. The lower limit shall apply at the transition frequencies.
 2. The limit decreases in line with the logarithm of the frequency in the range of 0.15 to 0.50 MHz.
 3. All emanations from a class A/B digital device or system, including any network of conductors and apparatus connected thereto, shall not exceed the level of field strengths specified above.

4.2.2 TEST INSTRUMENTS

DESCRIPTION & MANUFACTURER	MODEL NO.	SERIAL NO.	DATE OF CALIBRATION	DUE DATE OF CALIBRATION
Test Receiver ROHDE & SCHWARZ	ESCS30	100291	Nov. 30, 2010	Nov. 29, 2011
RF signal cable Woken	5D-FB	Cable-HYC01-01	Dec. 30, 2010	Dec. 29, 2011
LISN ROHDE & SCHWARZ	ESH3-Z5	100312	Jul. 07, 2011	Jul. 06, 2012
LISN ROHDE & SCHWARZ	ESH2-Z5	100100	Jan. 06, 2011	Jan. 05, 2012
LISN ROHDE & SCHWARZ	ESH3-Z5	835239/001	Feb. 22, 2011	Feb. 21, 2012
V-LISN SCHWARZBECK	NNBL 8226-2	8226-142	Jun. 30, 2011	Jun. 29, 2012
LISN ROHDE & SCHWARZ	ENV216	100072	Jun. 10, 2011	Jun. 09, 2012
Software ADT	ADT_Cond_ V7.3.7	NA	NA	NA

- NOTE:**
1. The calibration interval of the above test instruments is 12 months and the calibrations are traceable to NML/ROC and NIST/USA.
 2. The test was performed in HwaYa Shielded Room 1.
 3. The VCCI Site Registration No. is C-2040.

4.2.3 TEST PROCEDURES

- a. The EUT was placed 0.4 meters from the conducting wall of the shielded room with EUT being connected to the power mains through a line impedance stabilization network (LISN). Other support units were connected to the power mains through another LISN. The two LISNs provide 50 ohm/ 50uH of coupling impedance for the measuring instrument.
- b. Both lines of the power mains connected to the EUT were checked for maximum conducted interference.
- c. The frequency range from 150kHz to 30MHz was searched. Emission levels under (Limit - 20dB) was not recorded.

NOTE: All modes of operation were investigated and the worst-case emissions are reported.

4.2.4 DEVIATION FROM TEST STANDARD

No deviation.

4.2.5 TEST SETUP

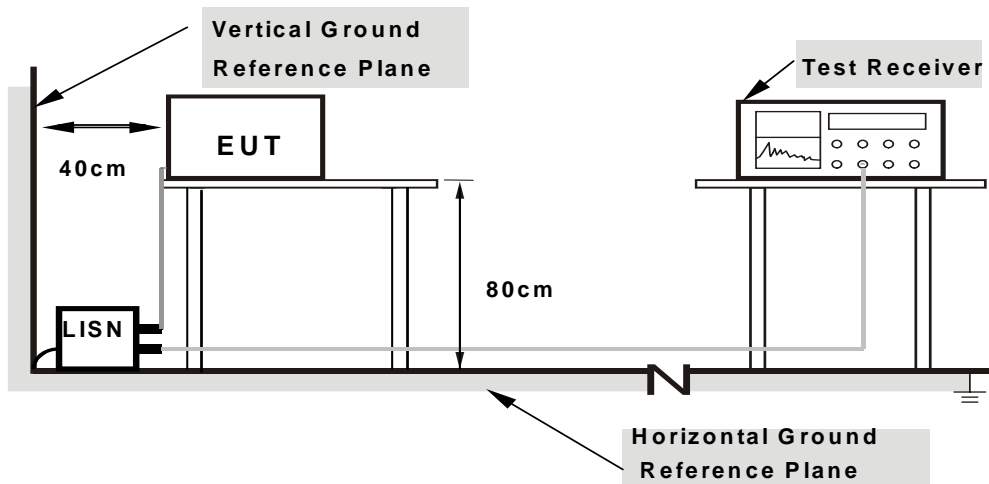

- Note:**
1. Support units were connected to second LISN.
 2. Both of LISNs (AMN) are 80 cm from EUT and at least 80 from other units and other metal planes

For the actual test configuration, please refer to the attached file (Test Setup Photo).

4.2.6 EUT OPERATING CONDITIONS

Same as 4.1.6.

4.2.7 TEST RESULTS

CONDUCTED WORST-CASE DATA :

PHASE	Line 1	6dB BANDWIDTH	9kHz
-------	--------	---------------	------

No	Freq. [MHz]	Corr. Factor (dB)	Reading Value		Emission Level		Limit		Margin	
			[dB (uV)]		[dB (uV)]		[dB (uV)]		(dB)	
			Q.P.	AV.	Q.P.	AV.	Q.P.	AV.	Q.P.	AV.
1	0.483	0.24	48.73	44.98	48.97	45.22	56.28	46.28	-7.31	-1.06
2	0.576	0.24	47.49	40.23	47.73	40.47	56.00	46.00	-8.27	-5.53
3	0.783	0.22	44.92	38.13	45.14	38.35	56.00	46.00	-10.86	-7.65
4	1.152	0.21	43.24	37.61	43.45	37.82	56.00	46.00	-12.55	-8.18
5	2.969	0.31	37.81	31.94	38.12	32.25	56.00	46.00	-17.88	-13.75
6	9.316	0.67	31.50	20.02	32.17	20.69	60.00	50.00	-27.83	-29.31

- REMARKS:**
1. Q.P. and AV. are abbreviations of quasi-peak and average individually.
 2. "-": The Quasi-peak reading value also meets average limit and measurement with the average detector is unnecessary.
 3. The emission levels of other frequencies were very low against the limit.
 4. Margin value = Emission level - Limit value
 5. Correction factor = Insertion loss + Cable loss
 6. Emission Level = Correction Factor + Reading Value.

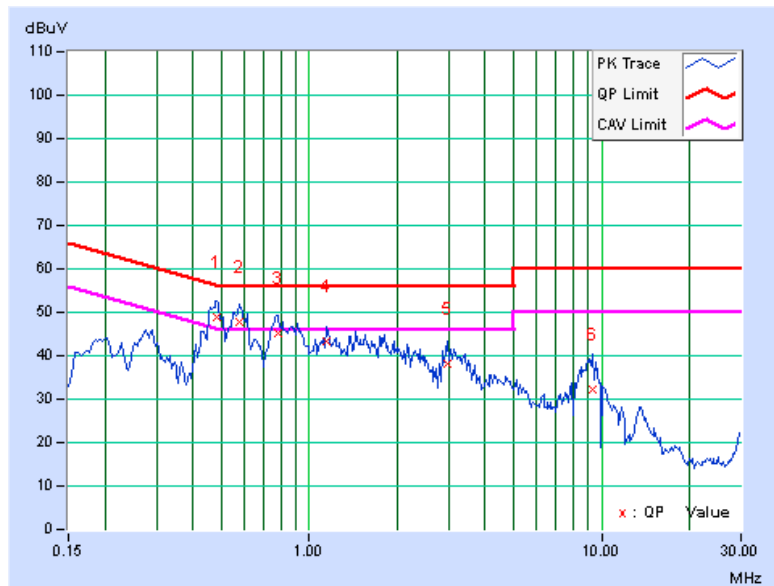

PHASE	Line 2	6dB BANDWIDTH	9kHz
-------	--------	---------------	------

No	Freq. [MHz]	Corr. Factor (dB)	Reading Value		Emission Level		Limit		Margin	
			[dB (uV)]		[dB (uV)]		[dB (uV)]		(dB)	
			Q.P.	AV.	Q.P.	AV.	Q.P.	AV.	Q.P.	AV.
1	0.482	0.24	45.12	41.55	45.36	41.79	56.31	46.31	-10.95	-4.52
2	0.584	0.24	44.69	37.42	44.93	37.66	56.00	46.00	-11.07	-8.34
3	0.779	0.26	42.24	34.16	42.50	34.42	56.00	46.00	-13.50	-11.58
4	1.727	0.29	39.03	33.64	39.32	33.93	56.00	46.00	-16.68	-12.07
5	3.273	0.38	37.17	32.48	37.55	32.86	56.00	46.00	-18.45	-13.14
6	8.766	0.64	35.33	25.41	35.97	26.05	60.00	50.00	-24.03	-23.95

- REMARKS:**
1. Q.P. and AV. are abbreviations of quasi-peak and average individually.
 2. "-": The Quasi-peak reading value also meets average limit and measurement with the average detector is unnecessary.
 3. The emission levels of other frequencies were very low against the limit.
 4. Margin value = Emission level - Limit value
 5. Correction factor = Insertion loss + Cable loss
 6. Emission Level = Correction Factor + Reading Value.

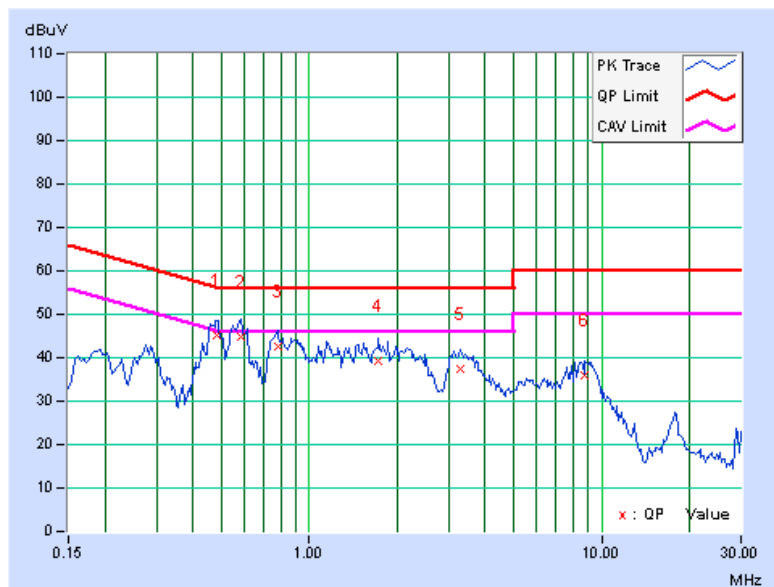

4.3 BAND EDGES MEASUREMENT

4.3.1 LIMITS OF BAND EDGES MEASUREMENT

Below –50dB of the highest emission level of operating band (in 100kHz Resolution Bandwidth).

4.3.2 TEST INSTRUMENTS

DESCRIPTION & MANUFACTURER	MODEL NO.	SERIAL NO.	DATE OF CALIBRATION	DUE DATE OF CALIBRATION
SPECTRUM ANALYZER R&S	FSP40	100039	Feb. 23, 2011	Feb. 22, 2012

NOTE: The calibration interval of the above test instruments is 12 months and the calibrations are traceable to NML/ROC and NIST/USA.

4.3.3 TEST PROCEDURE

The transmitter output was connected to the spectrum analyzer via a low lose cable. Set both RBW and VBW of spectrum analyzer to 100 kHz and 300 kHz with suitable frequency span including 100 MHz bandwidth from band edge. The band edges was measured and recorded.

The spectrum plots are attached on the following pages.

4.3.4 DEVIATION FROM TEST STANDARD

No deviation.

4.3.5 EUT OPERATING CONDITION

The software provided by client to enable the EUT under transmission condition continuously at lowest and highest channel frequencies individually.

4.3.6 TEST RESULTS

The spectrum plots are attached on the following images. D1 line indicates the highest level, and D2 line indicates the 50dB offset below D1. It shows compliance with the requirement in part 15.249 (d).

For 908.40 MHz

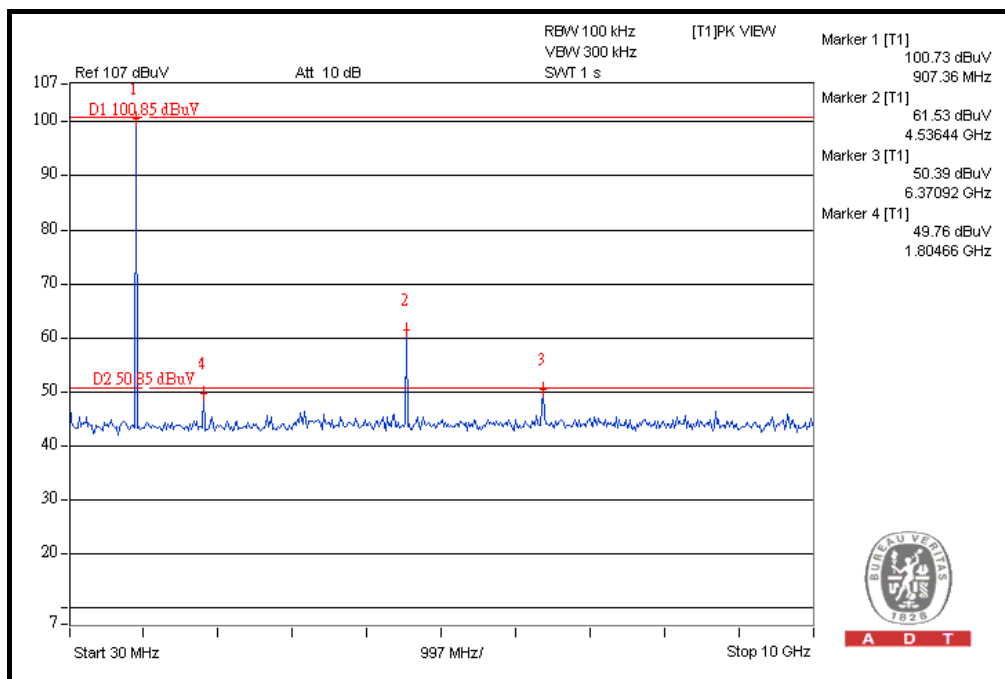
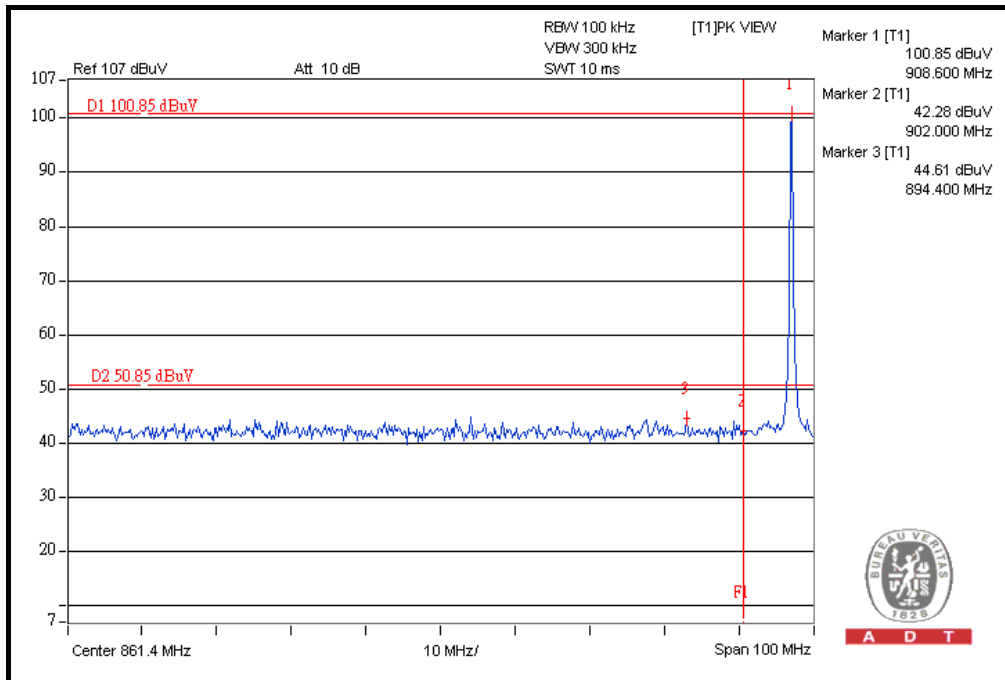



A D T

For 916.00 MHz

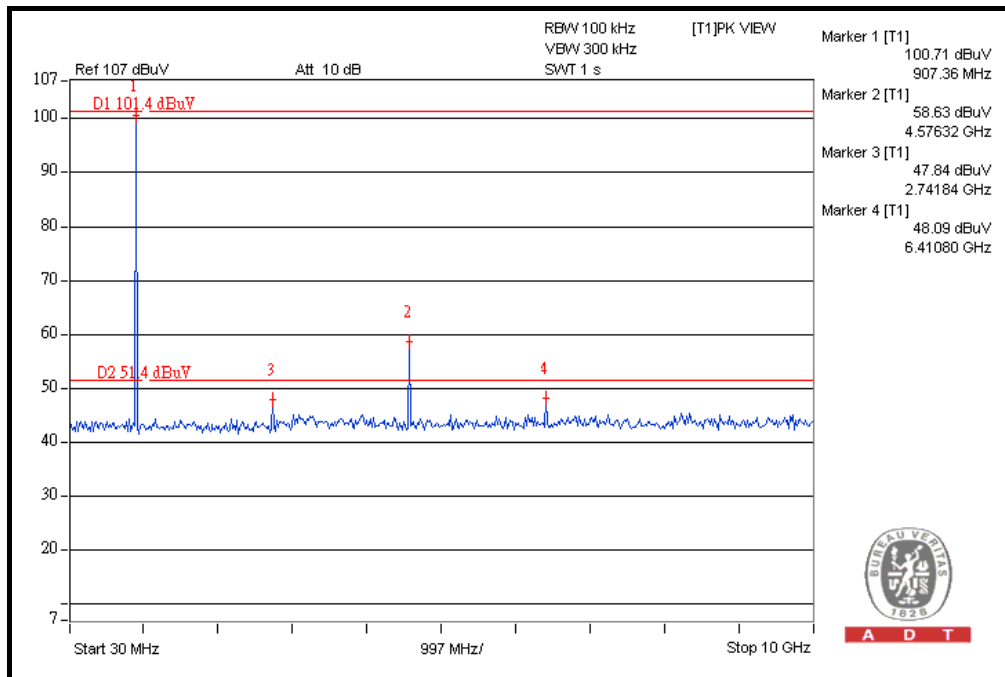
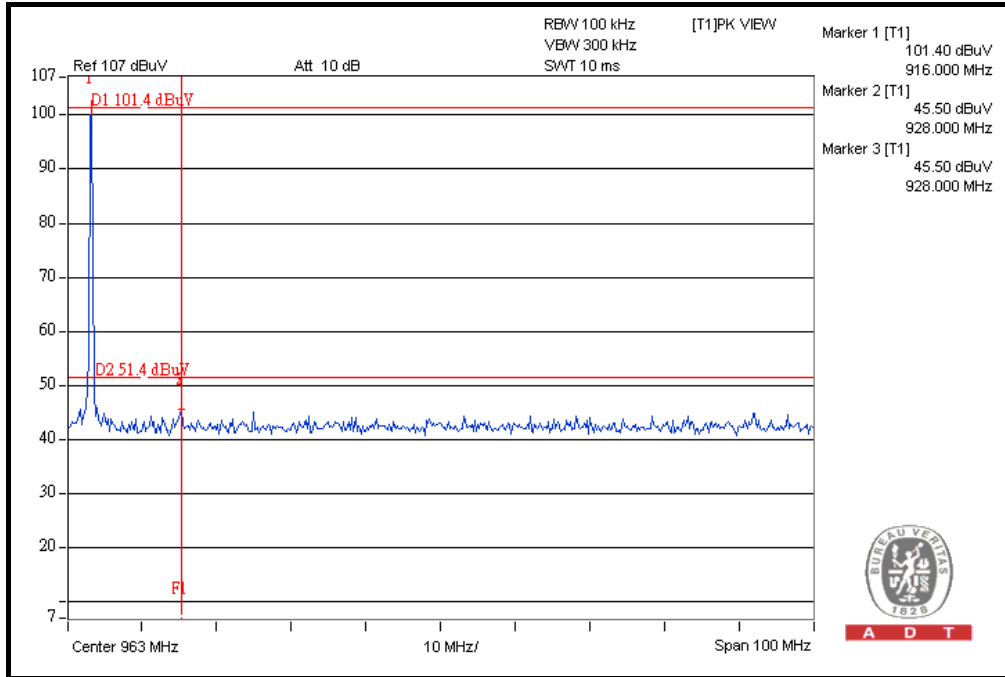



A D T

5. PHOTOGRAPHS OF THE TEST CONFIGURATION

Please refer to the attached file (Test Setup Photo).



6. INFORMATION ON THE TESTING LABORATORIES

We, Bureau Veritas Consumer Products Services (H.K.) Ltd., Taoyuan Branch, were founded in 1988 to provide our best service in EMC, Radio, Telecom and Safety consultation. Our laboratories are accredited and approved according to ISO/IEC 17025.

Copies of accreditation and authorization certificates of our laboratories obtained from approval agencies can be downloaded from our web site:

www.adt.com.tw/index.5.phtml. If you have any comments, please feel free to contact us at the following:

Linko EMC/RF Lab

Tel: 886-2-26052180

Fax: 886-2-26051924

Hsin Chu EMC/RF Lab

Tel: 886-3-5935343

Fax: 886-3-5935342

Hwa Ya EMC/RF/Safety/Telecom Lab

Tel: 886-3-3183232

Fax: 886-3-3185050

Email: service.adt@tw.bureauveritas.com

Web Site: www.adt.com.tw

The address and road map of all our labs can be found in our web site also.



A D T

7. APPENDIX A - MODIFICATIONS RECORDERS FOR ENGINEERING CHANGES TO THE EUT BY THE LAB

No any modifications are made to the EUT by the lab during the test.

--- END ---