



A D T

FCC TEST REPORT

REPORT NO.: RF120326C11
MODEL NO.: GL32200-xy (refer to item 3.1 for more detail)
FCC ID: Z3M-GGL32
RECEIVED: Mar. 26, 2012
TESTED: Mar. 31 ~ Apr. 07, 2012
ISSUED: Apr. 10, 2012

APPLICANT : Greenwave Reality Pte Ltd

ADDRESS : 41 Science Park Road, #03-01, The Gemini,
Science Park II, Singapore 117610.

ISSUED BY: Bureau Veritas Consumer Products Services
(H.K.) Ltd., Taoyuan Branch

LAB ADDRESS: No. 47, 14th Ling, Chia Pau Vil., Lin Kou Dist.,
New Taipei City, Taiwan (R.O.C.)

TEST LOCATION: No. 19, Hwa Ya 2nd Rd, Wen Hwa Tsuen, Kwei
Shan Hsiang, Taoyuan Hsien 333, Taiwan, R.O.C.

This test report consists of 47 pages in total. It may be duplicated completely for legal use with the approval of the applicant. It should not be reproduced except in full, without the written approval of our laboratory. The client should not use it to claim product, certification, approval or endorsement by TAF or any government agency. The test results in the report only apply to the tested sample. The test results in this report are traceable to the national or international standards.



Table of Contents

RELEASE CONTROL RECORD.....	3
1. CERTIFICATION	4
2. SUMMARY OF TEST RESULTS	5
2.1 MEASUREMENT UNCERTAINTY	5
3. GENERAL INFORMATION.....	6
3.1 GENERAL DESCRIPTION OF EUT	6
3.2 DESCRIPTION OF TEST MODES.....	7
3.2.1 TEST MODE APPLICABILITY AND TESTED CHANNEL DETAIL.....	8
3.3 DESCRIPTION OF SUPPORT UNITS	12
3.3.1 CONFIGURATION OF SYSTEM UNDER TEST	12
3.4 GENERAL DESCRIPTION OF APPLIED STANDARDS	13
4. TEST TYPES AND RESULTS	14
4.1 RADIATED EMISSION AND BAND EDGE MEASUREMENT.....	14
4.1.1 LIMITS OF RADIATED EMISSION MEASUREMENT.....	14
4.1.2 TEST INSTRUMENTS	15
4.1.3 TEST PROCEDURES	16
4.1.4 DEVIATION FROM TEST STANDARD	16
4.1.5 TEST SETUP	17
4.1.6 EUT OPERATING CONDITIONS	17
4.1.7 TEST RESULTS	18
4.2 CONDUCTED EMISSION MEASUREMENT	34
4.2.1 LIMITS OF CONDUCTED EMISSION MEASUREMENT.....	34
4.2.2 TEST INSTRUMENTS	34
4.2.3 TEST PROCEDURES	35
4.2.4 DEVIATION FROM TEST STANDARD	35
4.2.5 TEST SETUP	36
4.2.6 EUT OPERATING CONDITIONS	36
4.2.7 TEST RESULTS	37
5. PHOTOGRAPHS OF THE TEST CONFIGURATION.....	45
6. INFORMATION ON THE TESTING LABORATORIES	46
7. APPENDIX A - MODIFICATIONS RECORDERS FOR ENGINEERING CHANGES TO THE EUT BY THE LAB.....	47



A D T

RELEASE CONTROL RECORD

ISSUE NO.	REASON FOR CHANGE	DATE ISSUED
RF120326C11	Original release	Apr. 10, 2012



A D T

1. CERTIFICATION

PRODUCT: Lighting Gateway

MODEL NO.: GL32200-xy (refer to item 3.1 for more detail)

BRAND: greenWAVE

APPLICANT: Greenwave Reality Pte Ltd

TESTED: Mar. 31 ~ Apr. 07, 2012

TEST SAMPLE: ENGINEERING SAMPLE

STANDARDS: FCC Part 15, Subpart C (Section 15.249)

ANSI C63.10-2009

The above equipment (model: GL32200-xy) have been tested by **Bureau Veritas Consumer Products Services (H.K.) Ltd., Taoyuan Branch**, and found compliance with the requirement of the above standards. The test record, data evaluation & Equipment Under Test (EUT) configurations represented herein are true and accurate accounts of the measurements of the sample's EMC characteristics under the conditions specified in this report.

PREPARED BY : Andrea Hsia , DATE: Apr. 10, 2012
Andrea Hsia / Specialist

APPROVED BY : Gary Chang , DATE: Apr. 10, 2012
Gary Chang / Technical Manager

2. SUMMARY OF TEST RESULTS

The EUT has been tested according to the following specifications:

APPLIED STANDARD: FCC Part 15, Subpart C (Section 15.249)			
STANDARD PARAGRAPH	TEST TYPE	RESULT	REMARK
15.207	Conducted Emission Test	PASS	Meet the requirement of limit. Minimum passing margin is -21.86dB at 0.36875MHz.
15.209 15.249 15.249 (d)	Radiated Emission Test Band Edge Measurement Limit: 50dB less than the peak value of fundamental frequency or meet radiated emission limit in section 15.209	PASS	Meet the requirement of limit. Minimum passing margin is -1.0dB at 2405.00MHz.

2.1 MEASUREMENT UNCERTAINTY

Where relevant, the following measurement uncertainty levels have been estimated for tests performed on the EUT as specified in CISPR 16-4-2:

MEASUREMENT	FREQUENCY	UNCERTAINTY
Conducted emissions	9kHz~30MHz	2.44 dB
Radiated emissions	30MHz ~ 200MHz	3.34 dB
	200MHz ~1000MHz	3.35 dB
	1GHz ~ 18GHz	2.26 dB
	18GHz ~ 40GHz	1.94 dB

This uncertainty represents an expanded uncertainty expressed at approximately the 95% confidence level using a coverage factor of k=2.

3. GENERAL INFORMATION

3.1 GENERAL DESCRIPTION OF EUT

EUT	Lighting Gateway	
MODEL NO.	GL32200-xy (refer to NOTE for more details)	
POWER SUPPLY	5.0Vdc	
MODULATION TYPE	Z-Wave	2 Frequency Shift Keying (2FSK) (9.6kbpps) 2 Gaussian Frequency Shift Keying (2GFSK) (40kbps/100kbps)
	Zigbee	O-QPSK
DATA RATE	Z-Wave	9.6Kbps, 40Kbps, 100Kbps
	Zigbee	250kbps
OPERATING FREQUENCY	Z-Wave	908.42MHz, 908.4MHz, 916MHz
	Zigbee	2405~2480MHz
NUMBER OF CHANNEL	Z-Wave	3
	Zigbee	16
ANTENNA TYPE	Z-Wave	Dipole antenna with -0.9dBi gain
	Zigbee	PIFA antenna with 2.0dBi gain
DATA CABLE	2m non-shielded RJ45 cable without core	
I/O PORT	Refer to User's Manual	
ACCESSORY DEVICES	Adapter	

NOTE:

- The following models are electrically identical, different model names are for marketing purpose.

BRAND	MODEL	DESCRIPTION
greenWAVE	GL32200-xy	xy: A-Z or blank stands for customer branded code. EUT with white cover.
	GL32202-xy	xy: A-Z or blank stands for customer branded code. EUT with black cover.

- The EUT was powered by the following adapter:

BRAND:	Ktec
MODEL:	KSAS0060500100VUD
INPUT:	100-240Vac~, 50/60Hz, 0.18A
OUTPUT:	5.0Vdc, 1.0A
POWER LINE:	DC: 1.5m non-shielded cable without core

- The above EUT information is declared by the manufacturer and for more detailed features description, please refer to the manufacturer's specifications or User's Manual.



3.2 DESCRIPTION OF TEST MODES

FOR Z-Wave

3 channels are provided to this EUT.

CHANNEL	FREQ. (MHz)
1	908.42
2	908.40
3	916.00

FOR Zigbee

16 channels are provided to this EUT.

CHANNEL	FREQ. (MHz)	CHANNEL	FREQ. (MHz)	CHANNEL	FREQ. (MHz)	CHANNEL	FREQ. (MHz)
11	2405	15	2425	19	2445	23	2465
12	2410	16	2430	20	2450	24	2470
13	2415	17	2435	21	2455	25	2475
14	2420	18	2440	22	2460	26	2480

3.2.1 TEST MODE APPLICABILITY AND TESTED CHANNEL DETAIL

FOR Z-Wave

EUT CONFIGURE MODE	APPLICABLE TO				DESCRIPTION
	RE \geq 1G	RE<1G	PLC	BM	
-	√	√	√	√	

Where **RE<1G**: Radiated Emission below 1GHz **RE \geq 1G**: Radiated Emission above 1GHz
PLC: Power Line Conducted Emission **BM**: Bandedge Measurement

NOTE: The EUT had been pre-tested on the positioned of each 3 axis. The worst case was found when positioned on **X-plane**

RADIATED EMISSION TEST (ABOVE 1 GHz):

- Pre-Scan has been conducted to determine the worst-case mode from all possible combinations between available modulations and antenna ports (if EUT with antenna diversity architecture).
- Following channel(s) was (were) selected for the final test as listed below.

TESTED CHANNEL	OPERATING FREQUENCY	MODULATION TYPE
1	908.42MHz	2FSK
2	908.40MHz	2GFSK
3	916.00MHz	2GFSK

RADIATED EMISSION TEST (BELOW 1 GHz):

- Pre-Scan has been conducted to determine the worst-case mode from all possible combinations between available modulations and antenna ports (if EUT with antenna diversity architecture).
- Following channel(s) was (were) selected for the final test as listed below.

TESTED CHANNEL	OPERATING FREQUENCY	MODULATION TYPE
1	908.42MHz	2FSK
2	908.40MHz	2GFSK
3	916.00MHz	2GFSK

POWER LINE CONDUCTED EMISSION TEST:

- Pre-Scan has been conducted to determine the worst-case mode from all possible combinations between available modulations and antenna ports (if EUT with antenna diversity architecture).
- Following channel(s) was (were) selected for the final test as listed below.

TESTED CHANNEL	OPERATING FREQUENCY	MODULATION TYPE
1	908.42MHz	2FSK
2	908.40MHz	2GFSK
3	916.00MHz	2GFSK

BANDEDGE MEASUREMENT:

- Pre-Scan has been conducted to determine the worst-case mode from all possible combinations between available modulations and antenna ports (if EUT with antenna diversity architecture).
- Following channel(s) was (were) selected for the final test as listed below.

TESTED CHANNEL	OPERATING FREQUENCY	MODULATION TYPE
1	908.42MHz	2FSK
2	908.40MHz	2GFSK
3	916.00MHz	2GFSK

TEST CONDITION:

APPLICABLE TO	ENVIRONMENTAL CONDITIONS	INPUT POWER	TESTED BY
RE\geq1G	25deg. C, 65%RH 23deg. C, 65%RH	120Vac, 60Hz	Alan Wu
RE<1G	24deg. C, 65%RH	120Vac, 60Hz	Alan Wu
PLC	25deg. C, 65%RH	120Vac, 60Hz	Anderson Hong
BM	25deg. C, 65%RH	120Vac, 60Hz	Alan Wu

FOR Zigbee

EUT CONFIGURE MODE	APPLICABLE TO				DESCRIPTION
	RE≥1G	RE<1G	PLC	BM	
-	√	√	√	√	

Where **RE<1G**: Radiated Emission below 1GHz **RE≥1G**: Radiated Emission above 1GHz
PLC: Power Line Conducted Emission **BM**: Bandedge Measurement

NOTE: The EUT had been pre-tested on the positioned of each 3 axis. The worst case was found when positioned on **X-plane**

RADIATED EMISSION TEST (ABOVE 1 GHz):

- Pre-Scan has been conducted to determine the worst-case mode from all possible combinations between available modulations and antenna ports (if EUT with antenna diversity architecture).
- Following channel(s) was (were) selected for the final test as listed below.

AVAILABLE CHANNEL	TESTED CHANNEL	MODULATION TECHNOLOGY	MODULATION TYPE
11 to 26	11, 18, 26	DSSS	O-QPSK

RADIATED EMISSION TEST (BELOW 1 GHz):

- Pre-Scan has been conducted to determine the worst-case mode from all possible combinations between available modulations and antenna ports (if EUT with antenna diversity architecture).
- Following channel(s) was (were) selected for the final test as listed below.

AVAILABLE CHANNEL	TESTED CHANNEL	MODULATION TECHNOLOGY	MODULATION TYPE
11 to 26	11	DSSS	O-QPSK

POWER LINE CONDUCTED EMISSION TEST:

- Pre-Scan has been conducted to determine the worst-case mode from all possible combinations between available modulations and antenna ports (if EUT with antenna diversity architecture).
- Following channel(s) was (were) selected for the final test as listed below.

AVAILABLE CHANNEL	TESTED CHANNEL	MODULATION TECHNOLOGY	MODULATION TYPE
11 to 26	11	DSSS	O-QPSK

BANDEDGE MEASUREMENT:

- Pre-Scan has been conducted to determine the worst-case mode from all possible combinations between available modulations and antenna ports (if EUT with antenna diversity architecture).
- Following channel(s) was (were) selected for the final test as listed below.

AVAILABLE CHANNEL	TESTED CHANNEL	MODULATION TECHNOLOGY	MODULATION TYPE
11 to 26	11, 26	DSSS	O-QPSK



A D T

TEST CONDITION:

APPLICABLE TO	ENVIRONMENTAL CONDITIONS	INPUT POWER	TESTED BY
RE \geq 1G	25deg. C, 65%RH	120Vac, 60Hz	David Huang
RE $<$ 1G	24deg. C, 65%RH	120Vac, 60Hz	Alan Wu
PLC	25deg. C, 65%RH	120Vac, 60Hz	Anderson Hong
BM	25deg. C, 65%RH	120Vac, 60Hz	Alan Wu

3.3 DESCRIPTION OF SUPPORT UNITS

The EUT has been tested as an independent unit together with other necessary accessories or support units. The following support units or accessories were used to form a representative test configuration during the tests.

NO.	PRODUCT	BRAND	MODEL NO.	SERIAL NO.	FCC ID
1	NOTEBOOK	DELL	D820	21498926752	QDS-BRCM1020

NO.	SIGNAL CABLE DESCRIPTION OF THE ABOVE SUPPORT UNITS
1	NA

NOTE:

1. All power cords of the above support units are non shielded (1.8m).
2. Items 1 acted as communication partners to transfer data.

3.3.1 CONFIGURATION OF SYSTEM UNDER TEST

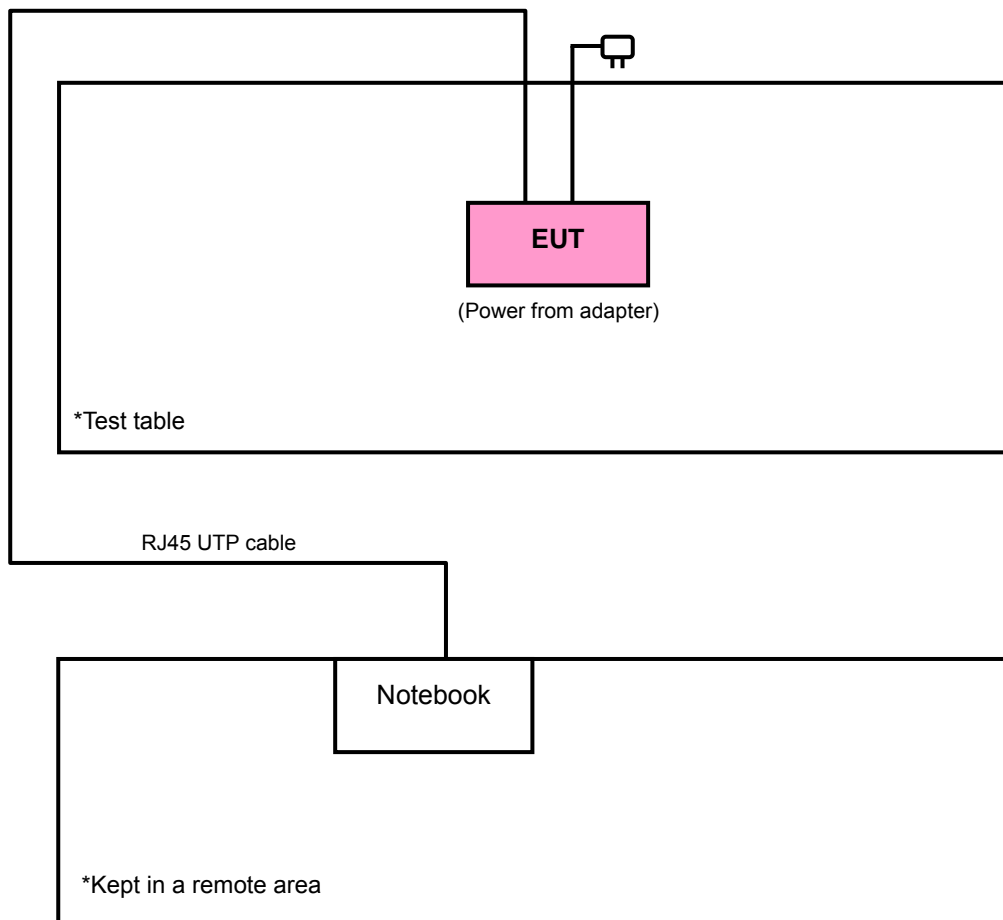



A D T

3.4 GENERAL DESCRIPTION OF APPLIED STANDARDS

The EUT is a RF Product. According to the specifications of the manufacturer, it must comply with the requirements of the following standards:

FCC Part 15, Subpart C (Section 15.249)

ANSI C63.10-2009

All test items have been performed and recorded as per the above standards.

NOTE: The EUT is also considered as a kind of computer peripheral, because the connection to computer is necessary for typical use. It has been verified to comply with the requirements of FCC Part 15, Subpart B, Class B (DoC). The test report has been issued separately.

4. TEST TYPES AND RESULTS

4.1 RADIATED EMISSION AND BAND EDGE MEASUREMENT

4.1.1 LIMITS OF RADIATED EMISSION MEASUREMENT

The field strength of emissions from intentional radiators operated within these frequency bands shall comply with the following

Fundamental Frequency	Field Strength of Fundamental (millivolts/meter)	Field Strength of Harmonics (microvolts/meter)
902 ~ 928 MHz	50	500
2400 ~ 2483.5 MHz	50	500
5725 ~ 5875 MHz	50	500
24 ~ 24.25 GHz	250	2500

Emissions radiated outside of the specified frequency bands, except for harmonics, shall be attenuated by at least 50 dB below the level of the fundamental or to the general radiated emission limits as below table, whichever is the lesser attenuation

Frequencies (MHz)	Field strength (microvolts/meter)	Measurement distance (meters)
0.009 ~ 0.490	2400/F(kHz)	300
0.490 ~ 1.705	24000/F(kHz)	30
1.705 ~ 30.0	30	30
30 ~ 88	100	3
88 ~ 216	150	3
216 ~ 960	200	3
Above 960	500	3

NOTE:

1. The lower limit shall apply at the transition frequencies.
2. Emission level (dBuV/m) = 20 log Emission level (uV/m).
3. For frequencies above 1000MHz, the field strength limits are based on average detector, however, the peak field strength of any emission shall not exceed the maximum permitted average limits, specified above by more than 20dB under any condition of modulation.

4.1.2 TEST INSTRUMENTS

DESCRIPTION & MANUFACTURER	MODEL NO.	SERIAL NO.	DATE OF CALIBRATION	DUE DATE OF CALIBRATION
Test Receiver ROHDE & SCHWARZ	ESI7	838496/016	Jan. 03, 2012	Jan. 02, 2013
Spectrum Analyzer ROHDE & SCHWARZ	FSP40	100269	Jan. 30, 2012	Jan. 29, 2013
BILOG Antenna SCHWARZBECK	VULB9168	9168-155	Apr. 12, 2011	Apr. 11, 2012
HORN Antenna SCHWARZBECK	BBHA 9120D	9120D-408	Jan. 05, 2012	Jan. 04, 2013
HORN Antenna SCHWARZBECK	BBHA 9170	148	Jul. 20, 2011	Jul. 19, 2012
Preamplifier Agilent	8449B	3008A01961	Oct. 29, 2011	Oct. 28, 2012
Preamplifier Agilent	8447D	2944A10738	Oct. 29, 2011	Oct. 28, 2012
RF signal cable HUBER+SUHNNER	SUCOFLEX 104	309220/4	Nov. 03, 2011	Nov. 02, 2012
RF signal cable HUBER+SUHNNER	SUCOFLEX 104	250724/4	Nov. 03, 2011	Nov. 02, 2012
RF signal cable HUBER+SUHNNER	SUCOFLEX 104	295012/4	Nov. 03, 2011	Nov. 02, 2012
Software ADT.	ADT_Radiated_ V7.6.15.9.2	NA	NA	NA
Antenna Tower inn-co GmbH	MA 4000	010303	NA	NA
Antenna Tower Controller inn-co GmbH	CO2000	019303	NA	NA
Turn Table ADT.	TT100.	TT93021704	NA	NA
Turn Table Controller ADT.	SC100.	SC93021704	NA	NA

- NOTE:**
1. The calibration interval of the above test instruments is 12 months and the calibrations are traceable to NML/ROC and NIST/USA.
 2. The test was performed in HwaYa Chamber 4.
 3. The horn antenna and HP preamplifier (model: 8449B) are used only for the measurement of emission frequency above 1GHz if tested.
 4. The FCC Site Registration No. is 460141.
 5. The IC Site Registration No. is IC7450F-4.

4.1.3 TEST PROCEDURES

- a. The EUT was placed on the top of a rotating table 0.8 meters above the ground at a 3 meter semi-anechoic chamber. The table was rotated 360 degrees to determine the position of the highest radiation.
- b. The EUT was set 3 meters away from the interference-receiving antenna, which was mounted on the top of a variable-height antenna tower.
- c. The antenna is a broadband antenna, and its height is varied from one meter to four meters above the ground to determine the maximum value of the field strength. Both horizontal and vertical polarizations of the antenna are set to make the measurement.
- d. For each suspected emission, the EUT was arranged to its worst case and then the antenna was tuned to heights from 1 meter to 4 meters and the rotatable table was turned from 0 degrees to 360 degrees to find the maximum reading.
- e. The test-receiver system was set to Peak Detect Function and Specified Bandwidth with Maximum Hold Mode.
- f. If the emission level of the EUT in peak mode was lower than the limit specified, then testing could be stopped and the peak values of the EUT would be reported. Otherwise the emissions would be re-tested one by one using peak, quasi-peak or average method as specified and then reported in a data sheet.

NOTE:

1. The resolution bandwidth and video bandwidth of test receiver/spectrum analyzer is 120kHz for Quasi-peak detection at frequency below 1GHz.
2. The resolution bandwidth of test receiver/spectrum analyzer is 1MHz and video bandwidth is 3MHz for Peak detection at frequency above 1GHz.
3. All modes of operation were investigated and the worst-case emissions are reported.

4.1.4 DEVIATION FROM TEST STANDARD

No deviation.

4.1.5 TEST SETUP

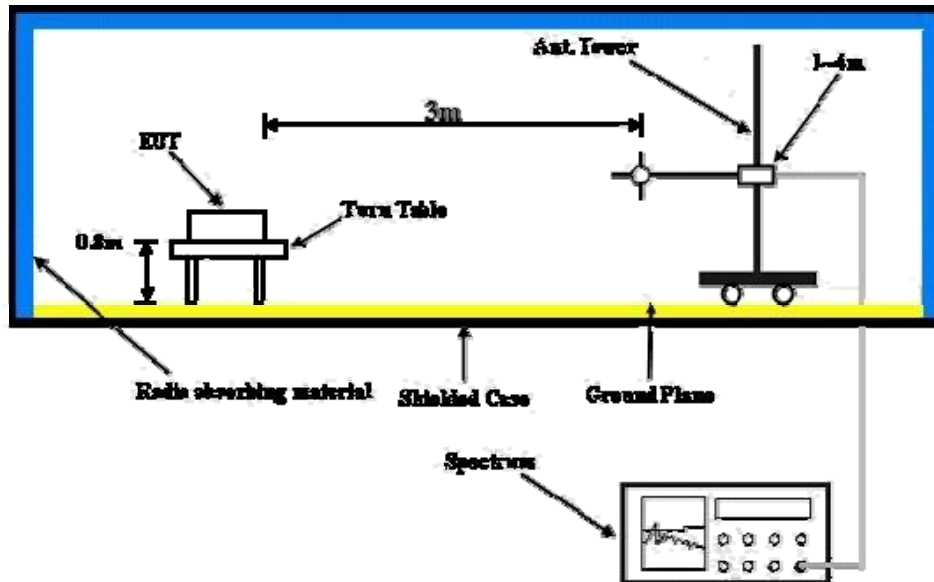

For the actual test configuration, please refer to the attached file (Test Setup Photo).

4.1.6 EUT OPERATING CONDITIONS

- Placed the EUT on a testing table.
- Set the EUT under transmission condition continuously at specific channel frequency.
- The necessary accessories enable the EUT in full functions.



4.1.7 TEST RESULTS

FOR Z-Wave

EUT TEST CONDITION		MEASUREMENT DETAIL	
CHANNEL	Channel 1 (908.42MHz)	FREQUENCY RANGE	Below 1000MHz
INPUT POWER	120Vac, 60 Hz	DETECTOR FUNCTION	Peak (PK) Average (AV)
ENVIRONMENTAL CONDITIONS	25deg. C, 65%RH	TESTED BY	Alan Wu

ANTENNA POLARITY & TEST DISTANCE: HORIZONTAL AT 3 M								
NO.	FREQ. (MHz)	EMISSION LEVEL (dBuV/m)	LIMIT (dBuV/m)	MARGIN (dB)	ANTENNA HEIGHT (m)	TABLE ANGLE (Degree)	RAW VALUE (dBuV)	CORRECTION FACTOR (dB/m)
1	*908.42	96.0 PK	114.0	-18.0	1.53 H	128	67.3	28.7
1	*908.42	88.7 AV	94.0	-5.3	1.53 H	128	60.0	28.7
ANTENNA POLARITY & TEST DISTANCE: VERTICAL AT 3 M								
NO.	FREQ. (MHz)	EMISSION LEVEL (dBuV/m)	LIMIT (dBuV/m)	MARGIN (dB)	ANTENNA HEIGHT (m)	TABLE ANGLE (Degree)	RAW VALUE (dBuV)	CORRECTION FACTOR (dB/m)
1	*908.42	99.5 PK	114.0	-14.5	1.27 V	359	70.8	28.7
1	*908.42	92.2 AV	94.0	-1.8	1.27 V	359	63.5	28.7

- REMARKS:**
1. Emission level (dBuV/m) = Raw Value (dBuV) + Correction Factor (dB/m).
 2. Correction Factor (dB/m) = Antenna Factor (dB/m) + Cable Factor (dB).
 3. The other emission levels were very low against the limit.
 4. Margin value = Emission level – Limit value.
 5. “ * ” : Fundamental frequency
 6. The average value of fundamental frequency is: Average = Peak value + 20log(Duty cycle) Where the duty factor is calculated from following formula:
 $20 \log (\text{Duty cycle}) = 20 \log (43 \text{ ms} / 100 \text{ ms}) = -7.3 \text{ dB}$

Please see page 27 for plotted duty.



A D T

EUT TEST CONDITION		MEASUREMENT DETAIL	
CHANNEL	Channel 2 (908.40MHz)	FREQUENCY RANGE	Below 1000MHz
INPUT POWER	120Vac, 60 Hz	DETECTOR FUNCTION	Peak (PK) Average (AV)
ENVIRONMENTAL CONDITIONS	25deg. C, 65%RH	TESTED BY	Alan Wu

ANTENNA POLARITY & TEST DISTANCE: HORIZONTAL AT 3 M								
NO.	FREQ. (MHz)	EMISSION LEVEL (dBuV/m)	LIMIT (dBuV/m)	MARGIN (dB)	ANTENNA HEIGHT (m)	TABLE ANGLE (Degree)	RAW VALUE (dBuV)	CORRECTION FACTOR (dB/m)
1	*908.40	94.1 PK	114.0	-19.9	1.00 H	43	65.5	28.6
1	*908.40	77.6 AV	94.0	-16.4	1.00 H	43	49.0	28.6
ANTENNA POLARITY & TEST DISTANCE: VERTICAL AT 3 M								
NO.	FREQ. (MHz)	EMISSION LEVEL (dBuV/m)	LIMIT (dBuV/m)	MARGIN (dB)	ANTENNA HEIGHT (m)	TABLE ANGLE (Degree)	RAW VALUE (dBuV)	CORRECTION FACTOR (dB/m)
1	*908.40	97.6 PK	114.0	-16.4	1.15 V	219	69.0	28.6
1	*908.40	81.1 AV	94.0	-12.9	1.15 V	219	52.5	28.6

- REMARKS:**
1. Emission level (dBuV/m) = Raw Value (dBuV) + Correction Factor (dB/m).
 2. Correction Factor (dB/m) = Antenna Factor (dB/m) + Cable Factor (dB).
 3. The other emission levels were very low against the limit.
 4. Margin value = Emission level – Limit value.
 5. “ * “ : Fundamental frequency
 6. The average value of fundamental frequency is: Average = Peak value + 20log(Duty cycle) Where the duty factor is calculated from following formula:
 $20 \log (\text{Duty cycle}) = 20 \log (14.88 \text{ ms} / 100 \text{ ms}) = -16.5 \text{ dB}$

Please see page 28 for plotted duty.



EUT TEST CONDITION		MEASUREMENT DETAIL	
CHANNEL	Channel 3 (916.00MHz)	FREQUENCY RANGE	Below 1000MHz
INPUT POWER	120Vac, 60 Hz	DETECTOR FUNCTION	Peak (PK) Average (AV)
ENVIRONMENTAL CONDITIONS	25deg. C, 65%RH	TESTED BY	Alan Wu

ANTENNA POLARITY & TEST DISTANCE: HORIZONTAL AT 3 M								
NO.	FREQ. (MHz)	EMISSION LEVEL (dBuV/m)	LIMIT (dBuV/m)	MARGIN (dB)	ANTENNA HEIGHT (m)	TABLE ANGLE (Degree)	RAW VALUE (dBuV)	CORRECTION FACTOR (dB/m)
1	*916.00	100.5 PK	114.0	-13.5	1.54 H	135	71.8	28.7
1	*916.00	80.7 AV	94.0	-13.3	1.54 H	135	52.0	28.7
ANTENNA POLARITY & TEST DISTANCE: VERTICAL AT 3 M								
NO.	FREQ. (MHz)	EMISSION LEVEL (dBuV/m)	LIMIT (dBuV/m)	MARGIN (dB)	ANTENNA HEIGHT (m)	TABLE ANGLE (Degree)	RAW VALUE (dBuV)	CORRECTION FACTOR (dB/m)
1	*916.00	101.1 PK	114.0	-12.9	1.18 V	232	72.4	28.7
1	*916.00	81.3 AV	94.0	-12.7	1.18 V	232	52.6	28.7

- REMARKS:**
1. Emission level (dBuV/m) = Raw Value (dBuV) + Correction Factor (dB/m).
 2. Correction Factor (dB/m) = Antenna Factor (dB/m) + Cable Factor (dB).
 3. The other emission levels were very low against the limit.
 4. Margin value = Emission level – Limit value.
 5. “ * “ : Fundamental frequency
 6. The average value of fundamental frequency is: Average = Peak value + 20log(Duty cycle) Where the duty factor is calculated from following formula:
 $20 \log (\text{Duty cycle}) = 20 \log (10.24 \text{ ms} / 100 \text{ ms}) = -19.8 \text{ dB}$

Please see page 29 for plotted duty.

ABOVE 1GHz DATA

EUT TEST CONDITION		MEASUREMENT DETAIL	
CHANNEL	Channel 1 (908.42MHz)	FREQUENCY RANGE	1 ~ 25GHz
INPUT POWER	120Vac, 60Hz	DETECTOR FUNCTION	Peak (PK) Average (AV)
ENVIRONMENTAL CONDITIONS	23deg. C, 65%RH	TESTED BY	Alan Wu

ANTENNA POLARITY & TEST DISTANCE: HORIZONTAL AT 3 M								
NO.	FREQ. (MHz)	EMISSION LEVEL (dBuV/m)	LIMIT (dBuV/m)	MARGIN (dB)	ANTENNA HEIGHT (m)	TABLE ANGLE (Degree)	RAW VALUE (dBuV)	CORRECTION FACTOR (dB/m)
1	1816.80	45.7 PK	74.0	-28.3	1.00 H	177	15.90	29.80
2	1816.80	38.4 AV	54.0	-15.6	1.00 H	177	8.60	29.80
3	6358.90	54.5 PK	74.0	-19.5	1.72 H	10	12.90	41.60
4	6358.90	47.2 AV	54.0	-6.8	1.72 H	10	5.60	41.60
5	8175.80	56.0 PK	74.0	-18.0	1.73 H	165	10.30	45.70
6	8175.80	48.7 AV	54.0	-5.3	1.73 H	165	3.00	45.70
ANTENNA POLARITY & TEST DISTANCE: VERTICAL AT 3 M								
NO.	FREQ. (MHz)	EMISSION LEVEL (dBuV/m)	LIMIT (dBuV/m)	MARGIN (dB)	ANTENNA HEIGHT (m)	TABLE ANGLE (Degree)	RAW VALUE (dBuV)	CORRECTION FACTOR (dB/m)
1	1816.80	50.3 PK	74.0	-23.7	1.24 V	216	20.50	29.80
2	1816.80	43.0 AV	54.0	-11.0	1.24 V	216	13.20	29.80
3	6358.90	56.5 PK	74.0	-17.5	1.11 V	347	14.90	41.60
4	6358.90	49.2 AV	54.0	-4.8	1.11 V	347	7.60	41.60
5	8175.80	58.0 PK	74.0	-16.0	1.60 V	41	12.30	45.70
6	8175.80	50.7 AV	54.0	-3.3	1.60 V	41	5.00	45.70

- REMARKS:**
1. Emission level (dBuV/m) = Raw Value (dBuV) + Correction Factor (dB/m).
 2. Correction Factor (dB/m) = Antenna Factor (dB/m) + Cable Factor (dB).
 3. The other emission levels were very low against the limit.
 4. Margin value = Emission level – Limit value.
 5. The average value of fundamental frequency is: Average = Peak value + 20log(Duty cycle) Where the duty factor is calculated from following formula:
 $20 \log (\text{Duty cycle}) = 20 \log (43 \text{ ms} / 100 \text{ ms}) = -7.3 \text{ dB}$

Please see page 27 for plotted duty.



A D T

EUT TEST CONDITION		MEASUREMENT DETAIL	
CHANNEL	Channel 2 (908.40MHz)	FREQUENCY RANGE	1 ~ 25GHz
INPUT POWER	120Vac, 60Hz	DETECTOR FUNCTION	Peak (PK) Average (AV)
ENVIRONMENTAL CONDITIONS	23deg. C, 65%RH	TESTED BY	Alan Wu

ANTENNA POLARITY & TEST DISTANCE: HORIZONTAL AT 3 M								
NO.	FREQ. (MHz)	EMISSION LEVEL (dBuV/m)	LIMIT (dBuV/m)	MARGIN (dB)	ANTENNA HEIGHT (m)	TABLE ANGLE (Degree)	RAW VALUE (dBuV)	CORRECTION FACTOR (dB/m)
1	1816.80	48.9 PK	74.0	-25.1	1.00 H	174	19.10	29.80
2	1816.80	32.4 AV	54.0	-21.6	1.00 H	174	2.60	29.80
3	6358.80	57.7 PK	74.0	-16.3	1.73 H	12	16.10	41.60
4	6358.80	41.2 AV	54.0	-12.8	1.73 H	12	-0.40	41.60
5	8175.60	58.2 PK	74.0	-15.8	1.72 H	162	12.50	45.70
6	8175.60	41.7 AV	54.0	-12.3	1.72 H	162	-4.00	45.70

ANTENNA POLARITY & TEST DISTANCE: VERTICAL AT 3 M								
NO.	FREQ. (MHz)	EMISSION LEVEL (dBuV/m)	LIMIT (dBuV/m)	MARGIN (dB)	ANTENNA HEIGHT (m)	TABLE ANGLE (Degree)	RAW VALUE (dBuV)	CORRECTION FACTOR (dB/m)
1	1816.80	55.0 PK	74.0	-19.0	1.39 V	188	25.20	29.80
2	1816.80	38.5 AV	54.0	-15.5	1.39 V	188	8.70	29.80
3	6358.80	60.1 PK	74.0	-13.9	1.11 V	349	18.50	41.60
4	6358.80	43.6 AV	54.0	-10.4	1.11 V	349	2.00	41.60
5	8175.60	60.7 PK	74.0	-13.3	1.60 V	40	15.00	45.70
6	8175.60	44.2 AV	54.0	-9.8	1.60 V	40	-1.50	45.70

- REMARKS:**
1. Emission level (dBuV/m) = Raw Value (dBuV) + Correction Factor (dB/m).
 2. Correction Factor (dB/m) = Antenna Factor (dB/m) + Cable Factor (dB).
 3. The other emission levels were very low against the limit.
 4. Margin value = Emission level – Limit value.
 5. The average value of fundamental frequency is: Average = Peak value + 20log(Duty cycle) Where the duty factor is calculated from following formula:
 $20 \log (\text{Duty cycle}) = 20 \log (14.88 \text{ ms} / 100 \text{ ms}) = -16.5 \text{ dB}$

Please see page 28 for plotted duty.



A D T

EUT TEST CONDITION		MEASUREMENT DETAIL	
CHANNEL	Channel 3 (916.00MHz)	FREQUENCY RANGE	1 ~ 25GHz
INPUT POWER	120Vac, 60Hz	DETECTOR FUNCTION	Peak (PK) Average (AV)
ENVIRONMENTAL CONDITIONS	23deg. C, 65%RH	TESTED BY	Alan Wu

ANTENNA POLARITY & TEST DISTANCE: HORIZONTAL AT 3 M								
NO.	FREQ. (MHz)	EMISSION LEVEL (dBuV/m)	LIMIT (dBuV/m)	MARGIN (dB)	ANTENNA HEIGHT (m)	TABLE ANGLE (Degree)	RAW VALUE (dBuV)	CORRECTION FACTOR (dB/m)
1	1832.00	50.0 PK	74.0	-24.0	1.00 H	178	20.10	29.90
2	1832.00	30.2 AV	54.0	-23.8	1.00 H	178	0.30	29.90
3	6412.00	55.0 PK	74.0	-19.0	1.10 H	345	13.20	41.80
4	6412.00	35.2 AV	54.0	-18.8	1.10 H	345	-6.60	41.80
5	8244.00	55.8 PK	74.0	-18.2	1.55 H	40	10.00	45.80
6	8244.00	36.0 AV	54.0	-18.0	1.55 H	40	-9.80	45.80
ANTENNA POLARITY & TEST DISTANCE: VERTICAL AT 3 M								
NO.	FREQ. (MHz)	EMISSION LEVEL (dBuV/m)	LIMIT (dBuV/m)	MARGIN (dB)	ANTENNA HEIGHT (m)	TABLE ANGLE (Degree)	RAW VALUE (dBuV)	CORRECTION FACTOR (dB/m)
1	1832.00	53.3 PK	74.0	-20.7	1.29 V	219	23.40	29.90
2	1832.00	33.5 AV	54.0	-20.5	1.29 V	219	3.60	29.90
3	6412.00	56.5 PK	74.0	-17.5	2.06 V	346	14.70	41.80
4	6412.00	36.7 AV	54.0	-17.3	2.06 V	346	-5.10	41.80
5	8244.00	57.9 PK	74.0	-16.1	1.00 V	31	12.10	45.80
6	8244.00	38.1 AV	54.0	-15.9	1.00 V	31	-7.70	45.80

- REMARKS:**
1. Emission level (dBuV/m) = Raw Value (dBuV) + Correction Factor (dB/m).
 2. Correction Factor (dB/m) = Antenna Factor (dB/m) + Cable Factor (dB).
 3. The other emission levels were very low against the limit.
 4. Margin value = Emission level – Limit value.
 5. The average value of fundamental frequency is: Average = Peak value + 20log(Duty cycle) Where the duty factor is calculated from following formula:
20 log (Duty cycle) = 20 log (10.24 ms / 100 ms) = -19.8 dB

Please see page 29 for plotted duty.

**BELOW 1GHz WORST-CASE DATA**

EUT TEST CONDITION		MEASUREMENT DETAIL	
CHANNEL	Channel 1 (908.42MHz)	FREQUENCY RANGE	Below 1000MHz
INPUT POWER	120Vac, 60Hz	DETECTOR FUNCTION	Quasi-Peak
ENVIRONMENTAL CONDITIONS	24deg. C, 65%RH	TESTED BY	Alan Wu

ANTENNA POLARITY & TEST DISTANCE: HORIZONTAL AT 3 M								
NO.	FREQ. (MHz)	EMISSION LEVEL (dBuV/m)	LIMIT (dBuV/m)	MARGIN (dB)	ANTENNA HEIGHT (m)	TABLE ANGLE (Degree)	RAW VALUE (dBuV)	CORRECTION FACTOR (dB/m)
1	47.40	25.3 QP	40.0	-14.7	1.50 H	51	11.20	14.10
2	125.17	21.2 QP	43.5	-22.3	2.00 H	278	8.60	12.60
3	249.60	30.6 QP	46.0	-15.4	1.25 H	81	17.00	13.60
4	500.42	28.3 QP	46.0	-17.7	1.75 H	226	7.20	21.10
5	624.85	31.6 QP	46.0	-14.4	1.25 H	207	7.90	23.70
6	751.23	34.9 QP	46.0	-11.1	1.00 H	13	9.10	25.80
ANTENNA POLARITY & TEST DISTANCE: VERTICAL AT 3 M								
NO.	FREQ. (MHz)	EMISSION LEVEL (dBuV/m)	LIMIT (dBuV/m)	MARGIN (dB)	ANTENNA HEIGHT (m)	TABLE ANGLE (Degree)	RAW VALUE (dBuV)	CORRECTION FACTOR (dB/m)
1	39.62	31.9 QP	40.0	-8.1	1.00 V	84	18.20	13.70
2	53.23	28.6 QP	40.0	-11.4	1.50 V	92	14.60	14.00
3	249.60	24.6 QP	46.0	-21.4	1.25 V	16	11.00	13.60
4	500.42	26.2 QP	46.0	-19.8	1.00 V	216	5.10	21.10
5	624.85	27.2 QP	46.0	-18.8	1.00 V	224	3.50	23.70
6	751.23	29.7 QP	46.0	-16.3	2.00 V	289	3.90	25.80

- REMARKS:**
1. Emission level (dBuV/m) = Raw Value (dBuV) + Correction Factor (dB/m).
 2. Correction Factor (dB/m) = Antenna Factor (dB/m) + Cable Factor (dB).
 3. The other emission levels were very low against the limit.
 4. Margin value = Emission level – Limit value.



A D T

EUT TEST CONDITION		MEASUREMENT DETAIL	
CHANNEL	Channel 2 (908.40MHz)	FREQUENCY RANGE	Below 1000MHz
INPUT POWER (SYSTEM)	120Vac, 60Hz	DETECTOR FUNCTION	Quasi-Peak
ENVIRONMENTAL CONDITIONS	24deg. C, 65%RH	TESTED BY	Alan Wu

ANTENNA POLARITY & TEST DISTANCE: HORIZONTAL AT 3 M								
NO.	FREQ. (MHz)	EMISSION LEVEL (dBuV/m)	LIMIT (dBuV/m)	MARGIN (dB)	ANTENNA HEIGHT (m)	TABLE ANGLE (Degree)	RAW VALUE (dBuV)	CORRECTION FACTOR (dB/m)
1	125.17	20.5 QP	43.5	-23.0	1.50 H	271	7.90	12.60
2	173.78	20.5 QP	43.5	-23.0	2.00 H	109	6.90	13.60
3	249.60	30.8 QP	46.0	-15.2	1.25 H	90	17.20	13.60
4	500.42	28.2 QP	46.0	-17.8	1.50 H	231	7.10	21.10
5	624.85	31.5 QP	46.0	-14.5	1.25 H	202	7.80	23.70
6	751.23	34.6 QP	46.0	-11.4	1.00 H	18	8.80	25.80
ANTENNA POLARITY & TEST DISTANCE: VERTICAL AT 3 M								
NO.	FREQ. (MHz)	EMISSION LEVEL (dBuV/m)	LIMIT (dBuV/m)	MARGIN (dB)	ANTENNA HEIGHT (m)	TABLE ANGLE (Degree)	RAW VALUE (dBuV)	CORRECTION FACTOR (dB/m)
1	61.01	30.4 QP	40.0	-9.6	1.25 V	91	16.90	13.50
2	125.17	19.4 QP	43.5	-24.1	1.00 V	301	6.80	12.60
3	249.60	24.9 QP	46.0	-21.1	1.00 V	16	11.30	13.60
4	500.42	26.3 QP	46.0	-19.7	1.00 V	192	5.20	21.10
5	624.85	27.3 QP	46.0	-18.7	1.00 V	224	3.60	23.70
6	751.23	29.7 QP	46.0	-16.3	1.25 V	51	3.90	25.80

- REMARKS:**
1. Emission level (dBuV/m) = Raw Value (dBuV) + Correction Factor (dB/m).
 2. Correction Factor (dB/m) = Antenna Factor (dB/m) + Cable Factor (dB).
 3. The other emission levels were very low against the limit.
 4. Margin value = Emission level – Limit value.



A D T

EUT TEST CONDITION		MEASUREMENT DETAIL	
CHANNEL	Channel 3 (916.00MHz)	FREQUENCY RANGE	Below 1000MHz
INPUT POWER	120Vac, 60Hz	DETECTOR FUNCTION	Quasi-Peak
ENVIRONMENTAL CONDITIONS	25deg. C, 65%RH	TESTED BY	David Huang

ANTENNA POLARITY & TEST DISTANCE: HORIZONTAL AT 3 M								
NO.	FREQ. (MHz)	EMISSION LEVEL (dBuV/m)	LIMIT (dBuV/m)	MARGIN (dB)	ANTENNA HEIGHT (m)	TABLE ANGLE (Degree)	RAW VALUE (dBuV)	CORRECTION FACTOR (dB/m)
1	125.17	20.8 QP	43.5	-22.7	1.75 H	279	8.20	12.60
2	173.78	21.4 QP	43.5	-22.1	1.75 H	261	7.80	13.60
3	249.60	30.9 QP	46.0	-15.1	1.25 H	96	17.30	13.60
4	500.42	28.3 QP	46.0	-17.7	1.75 H	231	7.20	21.10
5	624.85	32.9 QP	46.0	-13.1	1.25 H	213	9.20	23.70
6	751.23	35.1 QP	46.0	-10.9	1.00 H	328	9.30	25.80
ANTENNA POLARITY & TEST DISTANCE: VERTICAL AT 3 M								
NO.	FREQ. (MHz)	EMISSION LEVEL (dBuV/m)	LIMIT (dBuV/m)	MARGIN (dB)	ANTENNA HEIGHT (m)	TABLE ANGLE (Degree)	RAW VALUE (dBuV)	CORRECTION FACTOR (dB/m)
1	49.34	25.9 QP	40.0	-14.1	2.00 V	96	11.80	14.10
2	59.06	32.9 QP	40.0	-7.1	1.75 V	266	19.30	13.60
3	249.60	23.8 QP	46.0	-22.2	1.00 V	16	10.20	13.60
4	500.42	26.1 QP	46.0	-19.9	1.00 V	219	5.00	21.10
5	624.85	27.9 QP	46.0	-18.1	1.00 V	236	4.20	23.70
6	751.23	30.0 QP	46.0	-16.0	1.25 V	48	4.20	25.80

- REMARKS:**
1. Emission level (dBuV/m) = Raw Value (dBuV) + Correction Factor (dB/m).
 2. Correction Factor (dB/m) = Antenna Factor (dB/m) + Cable Factor (dB).
 3. The other emission levels were very low against the limit.
 4. Margin value = Emission level – Limit value.



A D T

Channel 1 (908.42MHz)

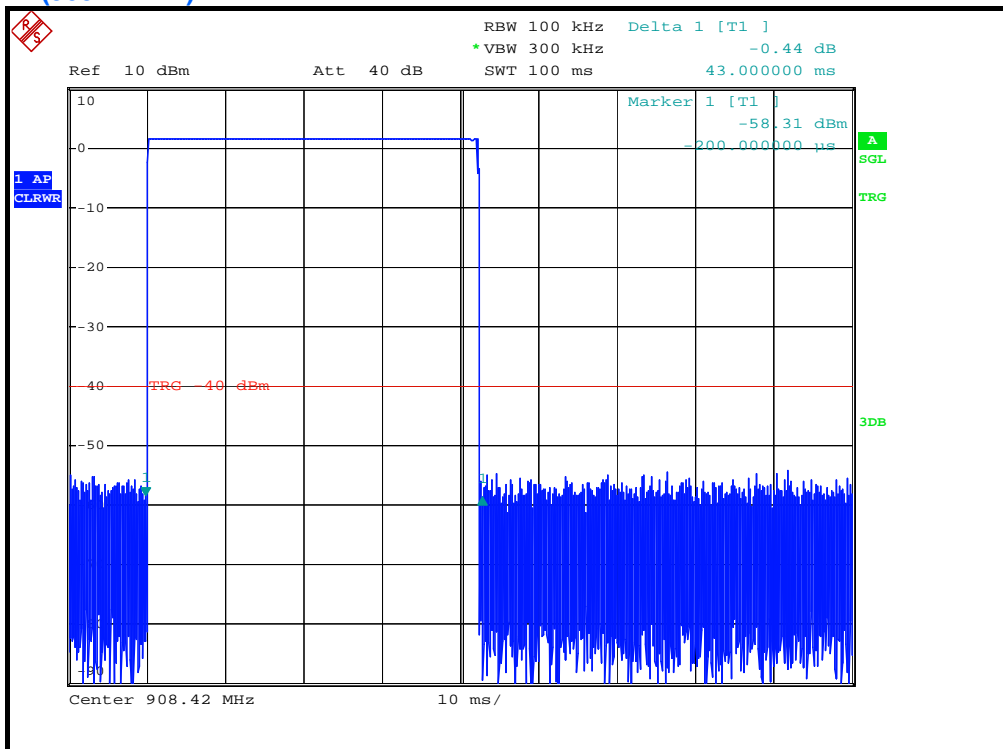

$$20 \log (\text{Duty cycle}) = 20 \log (43\text{ms} / 100 \text{ms}) = -7.3\text{dB}$$



A D T

Channel 2 (908.40MHz)

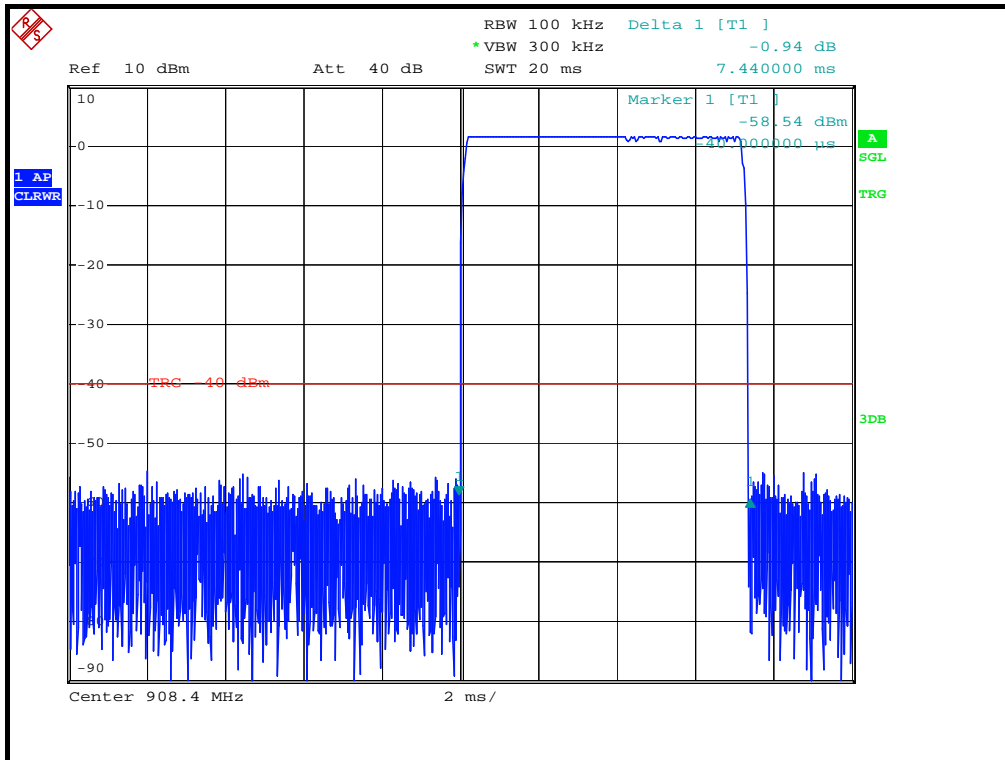
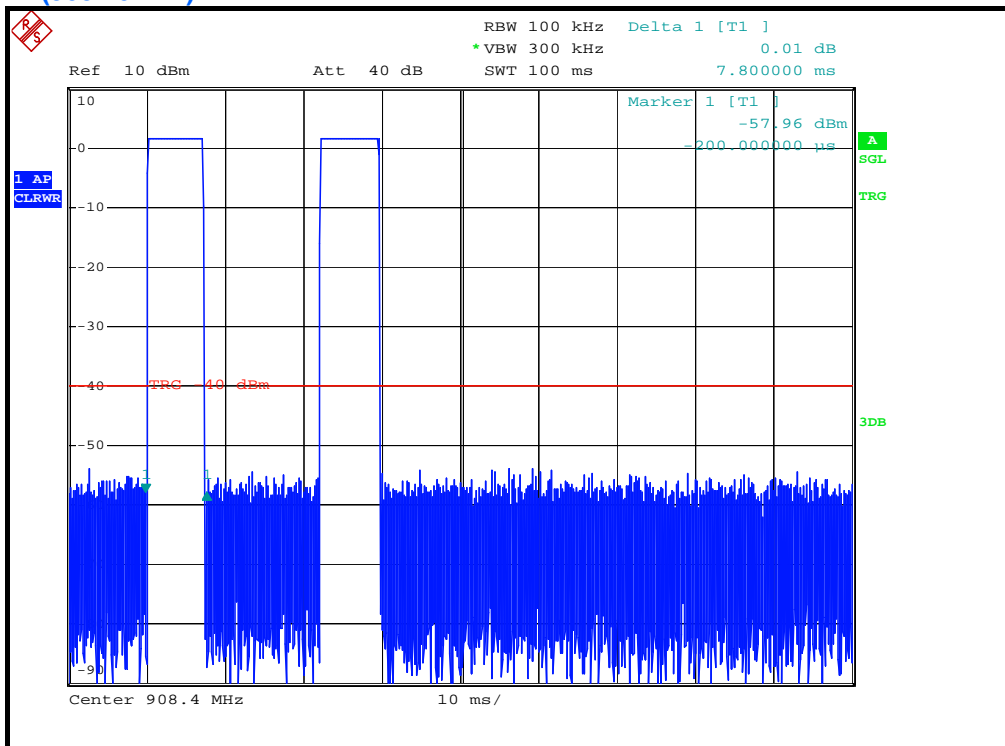

$$20 \log (\text{Duty cycle}) = 20 \log [(7.44 + 7.44) \text{ ms} / 100 \text{ ms}] = -16.5 \text{ dB}$$



A D T

Channel 3 (916.00MHz)

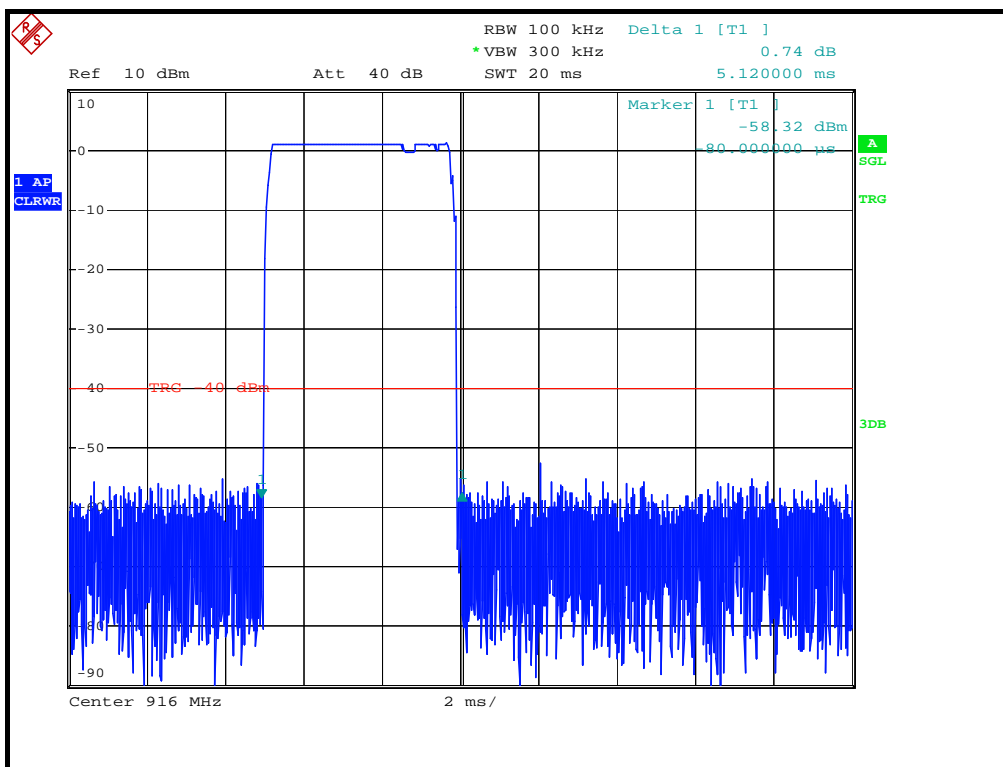
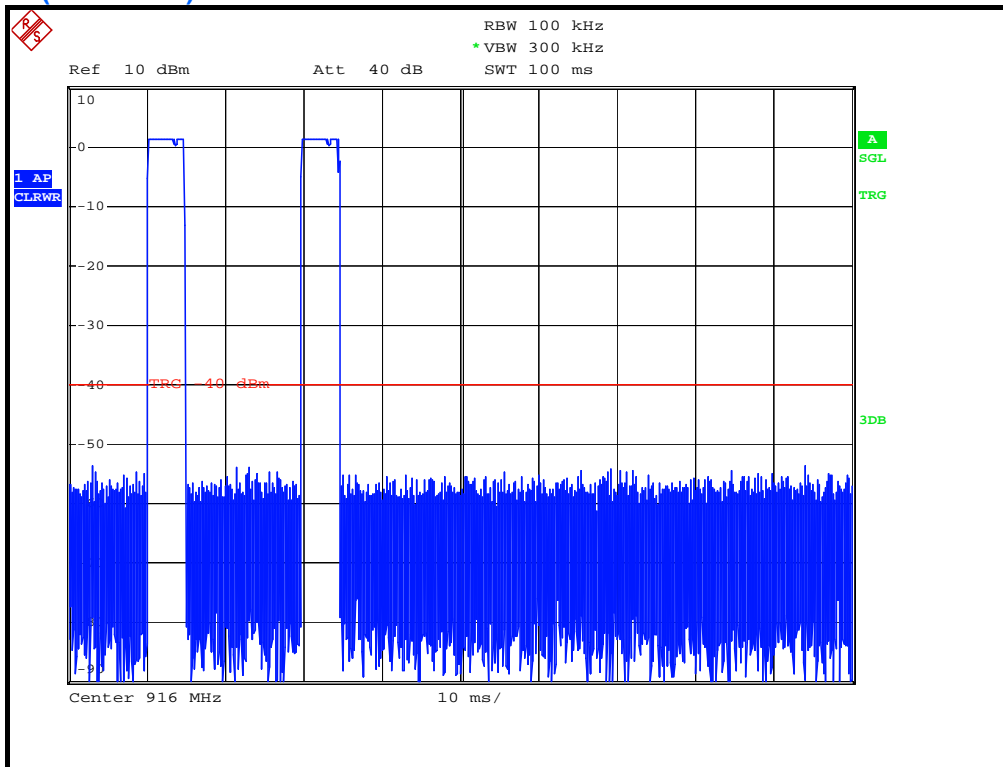

$$20 \log (\text{Duty cycle}) = 20 \log [(5.12 + 5.12) \text{ ms} / 100 \text{ ms}] = -19.8 \text{ dB}$$



A D T

FOR Zigbee

ABOVE 1GHz DATA

EUT TEST CONDITION		MEASUREMENT DETAIL	
CHANNEL	Channel 11	FREQUENCY RANGE	1 ~ 25GHz
INPUT POWER (SYSTEM)	120Vac, 60 Hz	DETECTOR FUNCTION	Peak (PK) Average (AV)
ENVIRONMENTAL CONDITIONS	25deg. C, 65%RH	TESTED BY	David Huang

ANTENNA POLARITY & TEST DISTANCE: HORIZONTAL AT 3 M								
NO.	FREQ. (MHz)	EMISSION LEVEL (dBuV/m)	LIMIT (dBuV/m)	MARGIN (dB)	ANTENNA HEIGHT (m)	TABLE ANGLE (Degree)	RAW VALUE (dBuV)	CORRECTION FACTOR (dB/m)
1	2390.00	37.3 PK	74.0	-36.7	1.00 H	222	5.30	32.00
2	2390.00	27.3 AV	54.0	-26.7	1.00 H	222	-4.70	32.00
3	2400.00	49.9 PK	74.0	-24.1	1.00 H	222	17.90	32.00
4	2400.00	39.9 AV	54.0	-14.1	1.00 H	222	7.90	32.00
5	*2405.00	91.1 PK	114.0	-22.9	1.00 H	222	59.10	32.00
6	*2405.00	87.0 AV	94.0	-7.0	1.00 H	222	55.00	32.00
7	4810.00	50.4 PK	74.0	-23.6	1.35 H	314	12.10	38.30
8	4810.00	39.3 AV	54.0	-14.7	1.35 H	314	1.00	38.30
ANTENNA POLARITY & TEST DISTANCE: VERTICAL AT 3 M								
NO.	FREQ. (MHz)	EMISSION LEVEL (dBuV/m)	LIMIT (dBuV/m)	MARGIN (dB)	ANTENNA HEIGHT (m)	TABLE ANGLE (Degree)	RAW VALUE (dBuV)	CORRECTION FACTOR (dB/m)
1	2390.00	38.5 PK	74.0	-35.5	1.00 V	280	6.50	32.00
2	2390.00	27.2 AV	54.0	-26.8	1.00 V	280	-4.80	32.00
3	2400.00	42.6 PK	74.0	-31.4	1.00 V	280	10.60	32.00
4	2400.00	32.8 AV	54.0	-21.2	1.00 V	280	0.80	32.00
5	*2405.00	97.5 PK	114.0	-16.5	1.36 V	280	65.50	32.00
6	*2405.00	93.0 AV	94.0	-1.0	1.36 V	280	61.00	32.00
7	4810.00	52.3 PK	74.0	-21.7	1.37 V	47	14.00	38.30
8	4810.00	41.6 AV	54.0	-12.4	1.37 V	47	3.30	38.30

REMARKS:

1. Emission level (dBuV/m) = Raw Value (dBuV) + Correction Factor (dB/m).
2. Correction Factor (dB/m) = Antenna Factor (dB/m) + Cable Factor (dB).
3. The other emission levels were very low against the limit.
4. Margin value = Emission level – Limit value.
5. “ * “: Fundamental frequency.

EUT TEST CONDITION		MEASUREMENT DETAIL	
CHANNEL	Channel 18	FREQUENCY RANGE	1 ~ 25GHz
INPUT POWER (SYSTEM)	120Vac, 60 Hz	DETECTOR FUNCTION	Peak (PK) Average (AV)
ENVIRONMENTAL CONDITIONS	25deg. C, 65%RH	TESTED BY	David Huang

ANTENNA POLARITY & TEST DISTANCE: HORIZONTAL AT 3 M								
NO.	FREQ. (MHz)	EMISSION LEVEL (dBuV/m)	LIMIT (dBuV/m)	MARGIN (dB)	ANTENNA HEIGHT (m)	TABLE ANGLE (Degree)	RAW VALUE (dBuV)	CORRECTION FACTOR (dB/m)
1	*2440.00	92.7 PK	114.0	-21.3	1.04 H	198	60.60	32.10
2	*2440.00	88.4 AV	94.0	-5.6	1.04 H	198	56.30	32.10
3	4880.00	51.9 PK	74.0	-22.1	1.46 H	314	13.40	38.50
4	4880.00	40.1 AV	54.0	-13.9	1.46 H	314	1.60	38.50
5	7320.00	53.1 PK	74.0	-20.9	1.00 H	265	8.70	44.40
6	7320.00	38.2 AV	54.0	-15.8	1.00 H	265	-6.20	44.40
ANTENNA POLARITY & TEST DISTANCE: VERTICAL AT 3 M								
NO.	FREQ. (MHz)	EMISSION LEVEL (dBuV/m)	LIMIT (dBuV/m)	MARGIN (dB)	ANTENNA HEIGHT (m)	TABLE ANGLE (Degree)	RAW VALUE (dBuV)	CORRECTION FACTOR (dB/m)
1	*2440.00	96.7 PK	114.0	-17.3	1.07 V	81	64.60	32.10
2	*2440.00	92.4 AV	94.0	-1.6	1.07 V	81	60.30	32.10
3	4880.00	51.0 PK	74.0	-23.0	1.00 V	341	12.50	38.50
4	4880.00	42.0 AV	54.0	-12.0	1.00 V	341	3.50	38.50
5	7320.00	53.2 PK	74.0	-20.8	1.00 V	125	8.80	44.40
6	7320.00	40.8 AV	54.0	-13.2	1.00 V	125	-3.60	44.40

REMARKS:

1. Emission level (dBuV/m) = Raw Value (dBuV) + Correction Factor (dB/m).
2. Correction Factor (dB/m) = Antenna Factor (dB/m) + Cable Factor (dB).
3. The other emission levels were very low against the limit.
4. Margin value = Emission level – Limit value.
5. “ * ”: Fundamental frequency.



A D T

EUT TEST CONDITION		MEASUREMENT DETAIL	
CHANNEL	Channel 26	FREQUENCY RANGE	1 ~ 25GHz
INPUT POWER (SYSTEM)	120Vac, 60 Hz	DETECTOR FUNCTION	Peak (PK) Average (AV)
ENVIRONMENTAL CONDITIONS	25deg. C, 65%RH	TESTED BY	David Huang

ANTENNA POLARITY & TEST DISTANCE: HORIZONTAL AT 3 M								
NO.	FREQ. (MHz)	EMISSION LEVEL (dBuV/m)	LIMIT (dBuV/m)	MARGIN (dB)	ANTENNA HEIGHT (m)	TABLE ANGLE (Degree)	RAW VALUE (dBuV)	CORRECTION FACTOR (dB/m)
1	*2480.00	92.9 PK	114.0	-21.1	1.01 H	192	60.60	32.30
2	*2480.00	88.3 AV	94.0	-5.7	1.01 H	192	56.00	32.30
3	2483.50	58.3 PK	74.0	-15.7	1.01 H	192	26.00	32.30
4	2483.50	47.6 AV	54.0	-6.4	1.01 H	192	15.30	32.30
5	4960.00	50.6 PK	74.0	-23.4	1.53 H	19	12.20	38.40
6	4960.00	40.8 AV	54.0	-13.2	1.53 H	19	2.40	38.40
ANTENNA POLARITY & TEST DISTANCE: VERTICAL AT 3 M								
NO.	FREQ. (MHz)	EMISSION LEVEL (dBuV/m)	LIMIT (dBuV/m)	MARGIN (dB)	ANTENNA HEIGHT (m)	TABLE ANGLE (Degree)	RAW VALUE (dBuV)	CORRECTION FACTOR (dB/m)
1	*2480.00	97.0 PK	114.0	-17.0	1.06 V	95	64.70	32.30
2	*2480.00	92.4 AV	94.0	-1.6	1.06 V	95	60.10	32.30
3	2483.50	63.4 PK	74.0	-10.6	1.06 V	95	31.10	32.30
4	2483.50	51.6 AV	54.0	-2.4	1.06 V	95	19.30	32.30
5	4960.00	52.5 PK	74.0	-21.5	1.00 V	360	14.10	38.40
6	4960.00	43.5 AV	54.0	-10.5	1.00 V	360	5.10	38.40

REMARKS:

1. Emission level (dBuV/m) = Raw Value (dBuV) + Correction Factor (dB/m).
2. Correction Factor (dB/m) = Antenna Factor (dB/m) + Cable Factor (dB).
3. The other emission levels were very low against the limit.
4. Margin value = Emission level – Limit value.
5. “ * ”: Fundamental frequency.

**BELOW 1GHz WORST-CASE DATA**

EUT TEST CONDITION		MEASUREMENT DETAIL	
CHANNEL	Channel 11	FREQUENCY RANGE	Below 1000MHz
INPUT POWER (SYSTEM)	120Vac, 60 Hz	DETECTOR FUNCTION	Quasi-Peak
ENVIRONMENTAL CONDITIONS	24deg. C, 65%RH	TESTED BY	Alan Wu

ANTENNA POLARITY & TEST DISTANCE: HORIZONTAL AT 3 M								
NO.	FREQ. (MHz)	EMISSION LEVEL (dBuV/m)	LIMIT (dBuV/m)	MARGIN (dB)	ANTENNA HEIGHT (m)	TABLE ANGLE (Degree)	RAW VALUE (dBuV)	CORRECTION FACTOR (dB/m)
1	125.17	21.8 QP	43.5	-21.7	2.00 H	262	9.20	12.60
2	173.78	21.0 QP	43.5	-22.5	1.75 H	270	7.40	13.60
3	249.60	34.8 QP	46.0	-11.2	1.25 H	93	21.20	13.60
4	500.42	29.5 QP	46.0	-16.5	1.75 H	229	8.40	21.10
5	624.85	29.6 QP	46.0	-16.4	1.25 H	219	5.90	23.70
6	751.23	31.3 QP	46.0	-14.7	1.00 H	164	5.50	25.80
ANTENNA POLARITY & TEST DISTANCE: VERTICAL AT 3 M								
NO.	FREQ. (MHz)	EMISSION LEVEL (dBuV/m)	LIMIT (dBuV/m)	MARGIN (dB)	ANTENNA HEIGHT (m)	TABLE ANGLE (Degree)	RAW VALUE (dBuV)	CORRECTION FACTOR (dB/m)
1	64.90	23.7 QP	40.0	-16.3	1.75 V	41	10.70	13.00
2	249.60	29.6 QP	46.0	-16.4	1.75 V	51	16.00	13.60
3	500.42	29.6 QP	46.0	-16.4	1.00 V	214	8.50	21.10
4	574.30	25.9 QP	46.0	-20.1	1.50 V	216	3.00	22.90
5	624.85	28.1 QP	46.0	-17.9	1.50 V	205	4.40	23.70
6	751.23	30.7 QP	46.0	-15.3	1.25 V	202	4.90	25.80

REMARKS:

1. Emission level (dBuV/m) = Raw Value (dBuV) + Correction Factor (dB/m).
2. Correction Factor (dB/m) = Antenna Factor (dB/m) + Cable Factor (dB).
3. The other emission levels were very low against the limit.
4. Margin value = Emission level – Limit value.



4.2 CONDUCTED EMISSION MEASUREMENT

4.2.1 LIMITS OF CONDUCTED EMISSION MEASUREMENT

FREQUENCY OF EMISSION (MHz)	CONDUCTED LIMIT (dB μ V)	
	Quasi-peak	Average
0.15-0.5	66 to 56	56 to 46
0.5-5	56	46
5-30	60	50

- NOTE:**
1. The lower limit shall apply at the transition frequencies.
 2. The limit decreases in line with the logarithm of the frequency in the range of 0.15 to 0.50 MHz.
 3. All emanations from a class A/B digital device or system, including any network of conductors and apparatus connected thereto, shall not exceed the level of field strengths specified above.

4.2.2 TEST INSTRUMENTS

DESCRIPTION & MANUFACTURER	MODEL NO.	SERIAL NO.	DATE OF CALIBRATION	DUE DATE OF CALIBRATION
Test Receiver ROHDE & SCHWARZ	ESCS30	100289	Nov. 19, 2011	Nov. 18, 2012
RF signal cable Woken	5D-FB	Cable-HYCO2-01	Dec. 22, 2011	Dec. 21, 2012
LISN ROHDE & SCHWARZ	ESH2-Z5	100100	Dec. 30, 2011	Dec. 29, 2012
LISN ROHDE & SCHWARZ	ESH3-Z5	100312	Jul. 07, 2011	Jul. 06, 2012
V-LISN SCHWARZBECK	NNBL 8226-2	8226-142	Jun. 30, 2011	Jun. 29, 2012
LISN ROHDE & SCHWARZ	ENV216	100072	Jun. 10, 2011	Jun. 09, 2012
Software ADT	ADT_Cond_ V7.3.7	NA	NA	NA

- NOTE:**
1. The calibration interval of the above test instruments is 12 months and the calibrations are traceable to NML/ROC and NIST/USA.
 2. The test was performed in HwaYa Shielded Room 2.
 3. The VCCI Site Registration No. is C-2047.

4.2.3 TEST PROCEDURES

- a. The EUT was placed 0.4 meters from the conducting wall of the shielded room with EUT being connected to the power mains through a line impedance stabilization network (LISN). Other support units were connected to the power mains through another LISN. The two LISNs provide 50 ohm/ 50uH of coupling impedance for the measuring instrument.
- b. Both lines of the power mains connected to the EUT were checked for maximum conducted interference.
- c. The frequency range from 150kHz to 30MHz was searched. Emission levels under (Limit - 20dB) was not recorded.

NOTE: All modes of operation were investigated and the worst-case emissions are reported.

4.2.4 DEVIATION FROM TEST STANDARD

No deviation.

4.2.5 TEST SETUP

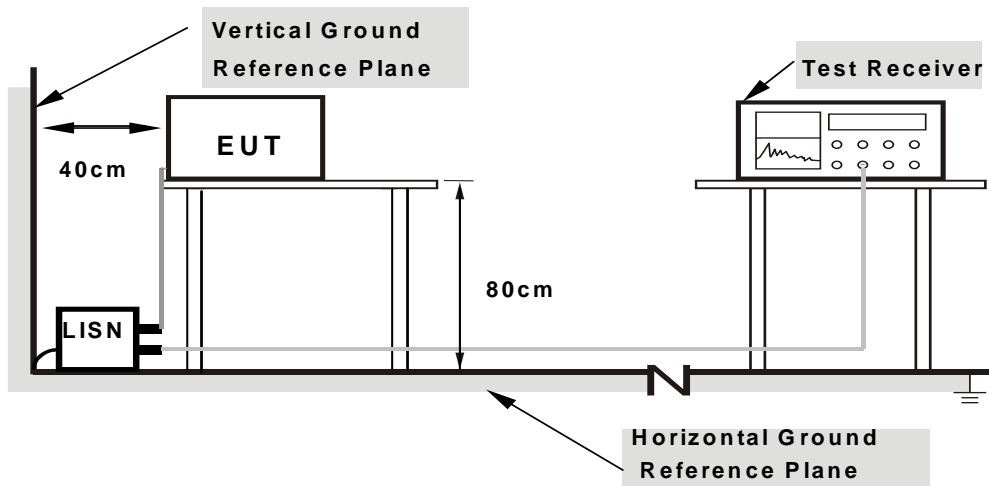

- Note:**
1. Support units were connected to second LISN.
 2. Both of LISNs (AMN) are 80 cm from EUT and at least 80 cm from other units and other metal planes

For the actual test configuration, please refer to the attached file (Test Setup Photo).

4.2.6 EUT OPERATING CONDITIONS

Same as 4.1.6.

4.2.7 TEST RESULTS

CONDUCTED WORST-CASE DATA :
FOR Z-WAVE

CHANNEL	Channel 1 (908.42MHz)	PHASE	Line 1
6dB BANDWIDTH	9kHz		

No	Freq. [MHz]	Corr. Factor (dB)	Reading Value [dB (uV)]		Emission Level [dB (uV)]		Limit [dB (uV)]		Margin (dB)	
			Q.P.	AV.	Q.P.	AV.	Q.P.	AV.	Q.P.	AV.
1	0.15391	0.15	37.42	25.34	37.57	25.49	65.79	55.79	-28.22	-30.30
2	0.36875	0.17	33.18	26.31	33.35	26.48	58.53	48.53	-25.18	-22.05
3	0.97813	0.19	21.20	10.34	21.39	10.53	56.00	46.00	-34.61	-35.47
4	1.71875	0.24	23.69	14.07	23.93	14.31	56.00	46.00	-32.07	-31.69
5	7.30078	0.39	15.51	10.81	15.90	11.20	60.00	50.00	-44.10	-38.80
6	22.69141	0.60	18.88	10.98	19.48	11.58	60.00	50.00	-40.52	-38.42

REMARKS:

1. Q.P. and AV. are abbreviations of quasi-peak and average individually.
2. The emission levels of other frequencies were very low against the limit.
3. Margin value = Emission level - Limit value
4. Correction factor = Insertion loss + Cable loss
5. Emission Level = Correction Factor + Reading Value.

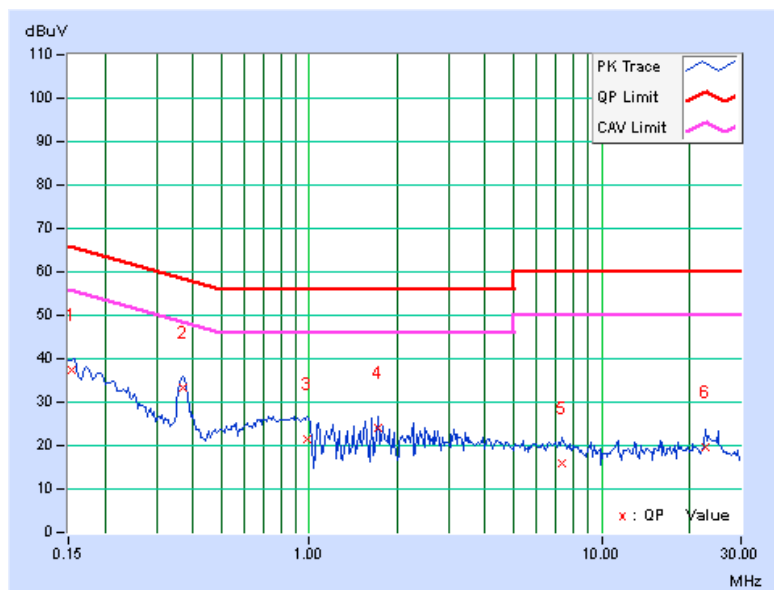

CHANNEL	Channel 1 (908.42MHz)	PHASE	Line 2
6dB BANDWIDTH	9kHz		

No	Freq.	Corr.	Reading Value		Emission Level		Limit		Margin	
	[MHz]	Factor	[dB (uV)]		[dB (uV)]		[dB (uV)]		(dB)	
		(dB)	Q.P.	AV.	Q.P.	AV.	Q.P.	AV.	Q.P.	AV.
1	0.15781	0.13	38.53	22.58	38.66	22.71	65.58	55.58	-26.92	-32.87
2	0.21641	0.14	32.72	17.41	32.86	17.55	62.96	52.96	-30.09	-35.40
3	0.85313	0.18	19.14	11.52	19.32	11.70	56.00	46.00	-36.68	-34.30
4	1.67969	0.24	19.40	11.52	19.64	11.76	56.00	46.00	-36.36	-34.24
5	6.07422	0.39	7.79	-0.24	8.18	0.15	60.00	50.00	-51.82	-49.85
6	22.20703	0.68	14.31	4.03	14.99	4.71	60.00	50.00	-45.01	-45.29

REMARKS:

1. Q.P. and AV. are abbreviations of quasi-peak and average individually.
2. The emission levels of other frequencies were very low against the limit.
3. Margin value = Emission level - Limit value
4. Correction factor = Insertion loss + Cable loss
5. Emission Level = Correction Factor + Reading Value.

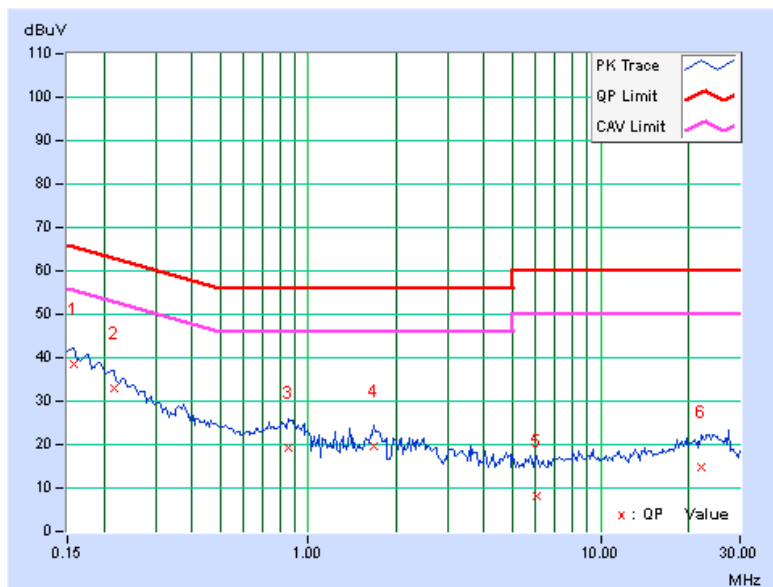

CHANNEL	Channel 2 (908.40MHz)	PHASE	Line 1
6dB BANDWIDTH	9kHz		

No	Freq. [MHz]	Corr. Factor (dB)	Reading Value		Emission Level		Limit		Margin	
			[dB (uV)]		[dB (uV)]		[dB (uV)]		(dB)	
			Q.P.	AV.	Q.P.	AV.	Q.P.	AV.	Q.P.	AV.
1	0.15781	0.15	37.08	22.50	37.23	22.65	65.58	55.58	-28.35	-32.93
2	0.36875	0.17	33.47	26.50	33.64	26.67	58.53	48.53	-24.89	-21.86
3	0.81016	0.18	21.69	15.00	21.87	15.18	56.00	46.00	-34.13	-30.82
4	1.63672	0.23	23.59	12.86	23.82	13.09	56.00	46.00	-32.18	-32.91
5	7.15234	0.39	15.47	10.60	15.86	10.99	60.00	50.00	-44.14	-39.01
6	26.92969	0.55	12.89	5.09	13.44	5.64	60.00	50.00	-46.56	-44.36

REMARKS:

1. Q.P. and AV. are abbreviations of quasi-peak and average individually.
2. The emission levels of other frequencies were very low against the limit.
3. Margin value = Emission level - Limit value
4. Correction factor = Insertion loss + Cable loss
5. Emission Level = Correction Factor + Reading Value.

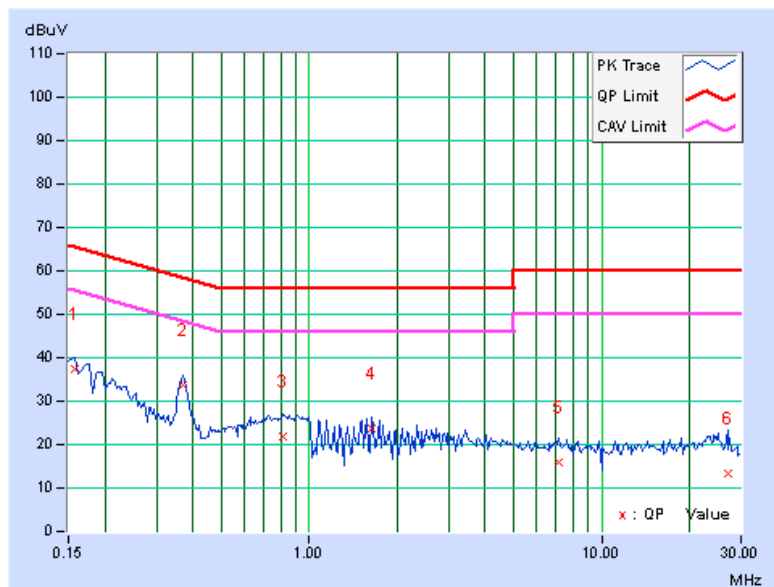



A D T

CHANNEL	Channel 2 (908.40MHz)	PHASE	Line 2
6dB BANDWIDTH	9kHz		

No	Freq. [MHz]	Corr. Factor (dB)	Reading Value		Emission Level		Limit		Margin	
			[dB (uV)]		[dB (uV)]		[dB (uV)]		(dB)	
			Q.P.	AV.	Q.P.	AV.	Q.P.	AV.	Q.P.	AV.
1	0.15391	0.13	40.21	26.58	40.34	26.71	65.79	55.79	-25.45	-29.08
2	0.21641	0.14	33.42	17.90	33.56	18.04	62.96	52.96	-29.39	-34.91
3	0.91172	0.19	17.87	10.17	18.06	10.36	56.00	46.00	-37.94	-35.64
4	1.78516	0.24	19.22	11.74	19.46	11.98	56.00	46.00	-36.54	-34.02
5	8.05859	0.44	10.07	0.92	10.51	1.36	60.00	50.00	-49.49	-48.64
6	25.00000	0.64	25.00	14.65	25.64	15.29	60.00	50.00	-34.36	-34.71

REMARKS:

1. Q.P. and AV. are abbreviations of quasi-peak and average individually.
2. The emission levels of other frequencies were very low against the limit.
3. Margin value = Emission level - Limit value
4. Correction factor = Insertion loss + Cable loss
5. Emission Level = Correction Factor + Reading Value.

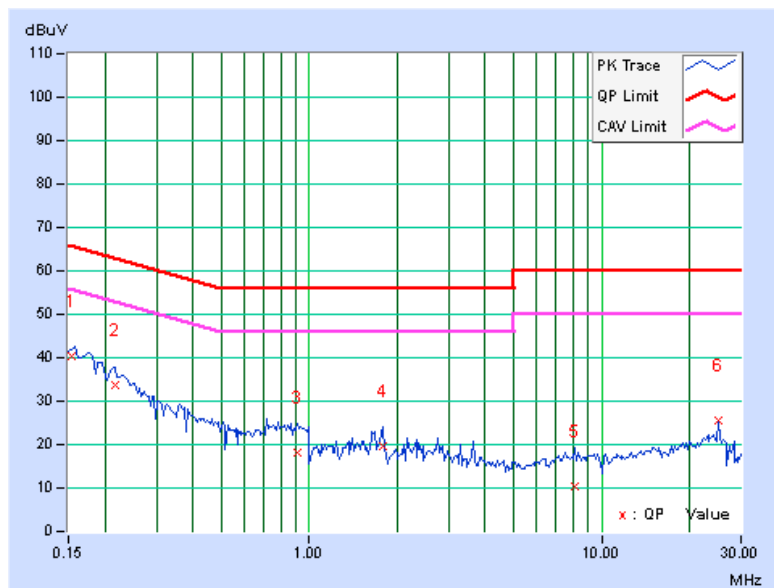

CHANNEL	Channel 3 (916.00MHz)	PHASE	Line 1
6dB BANDWIDTH	9kHz		

No	Freq. [MHz]	Corr. Factor (dB)	Reading Value		Emission Level		Limit		Margin	
			[dB (uV)]		[dB (uV)]		[dB (uV)]		(dB)	
			Q.P.	AV.	Q.P.	AV.	Q.P.	AV.	Q.P.	AV.
1	0.16172	0.15	32.06	15.66	32.21	15.81	65.38	55.38	-33.17	-39.57
2	0.36875	0.17	33.06	26.20	33.23	26.37	58.53	48.53	-25.30	-22.16
3	0.87656	0.19	21.84	13.71	22.03	13.90	56.00	46.00	-33.97	-32.10
4	1.54297	0.23	22.26	14.15	22.49	14.38	56.00	46.00	-33.51	-31.62
5	8.10156	0.40	14.20	8.81	14.60	9.21	60.00	50.00	-45.40	-40.79
6	22.69922	0.60	18.39	9.94	18.99	10.54	60.00	50.00	-41.01	-39.46

REMARKS:

1. Q.P. and AV. are abbreviations of quasi-peak and average individually.
2. The emission levels of other frequencies were very low against the limit.
3. Margin value = Emission level - Limit value
4. Correction factor = Insertion loss + Cable loss
5. Emission Level = Correction Factor + Reading Value.

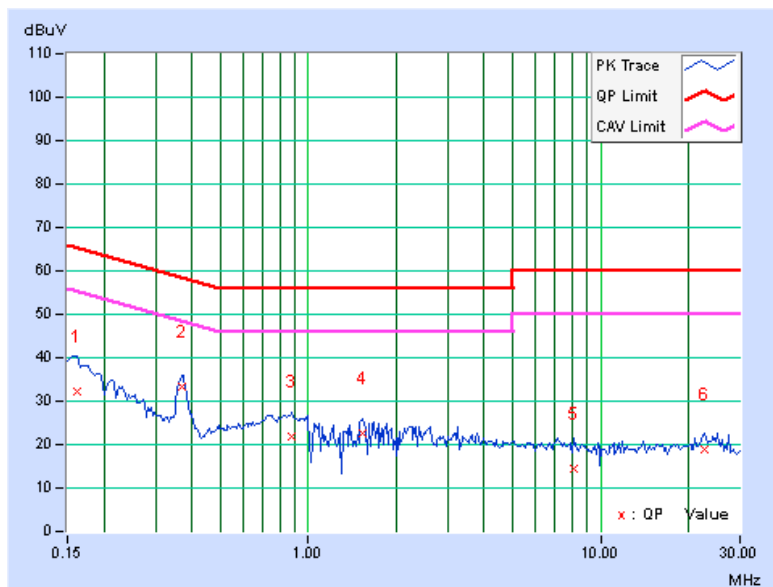

CHANNEL	Channel 3 (916.40MHz)	PHASE	Line 2
6dB BANDWIDTH	9kHz		

No	Freq.	Corr.	Reading Value		Emission Level		Limit		Margin	
	[MHz]	Factor	[dB (uV)]		[dB (uV)]		[dB (uV)]		(dB)	
		(dB)	Q.P.	AV.	Q.P.	AV.	Q.P.	AV.	Q.P.	AV.
1	0.15781	0.13	38.09	22.66	38.22	22.79	65.58	55.58	-27.36	-32.79
2	0.21641	0.14	32.42	16.75	32.56	16.89	62.96	52.96	-30.39	-36.06
3	0.87656	0.18	18.31	10.84	18.49	11.02	56.00	46.00	-37.51	-34.98
4	2.33203	0.27	16.90	9.67	17.17	9.94	56.00	46.00	-38.83	-36.06
5	7.97266	0.44	10.32	1.45	10.76	1.89	60.00	50.00	-49.24	-48.11
6	25.00000	0.64	24.97	14.71	25.61	15.35	60.00	50.00	-34.39	-34.65

REMARKS:

1. Q.P. and AV. are abbreviations of quasi-peak and average individually.
2. The emission levels of other frequencies were very low against the limit.
3. Margin value = Emission level - Limit value
4. Correction factor = Insertion loss + Cable loss
5. Emission Level = Correction Factor + Reading Value.

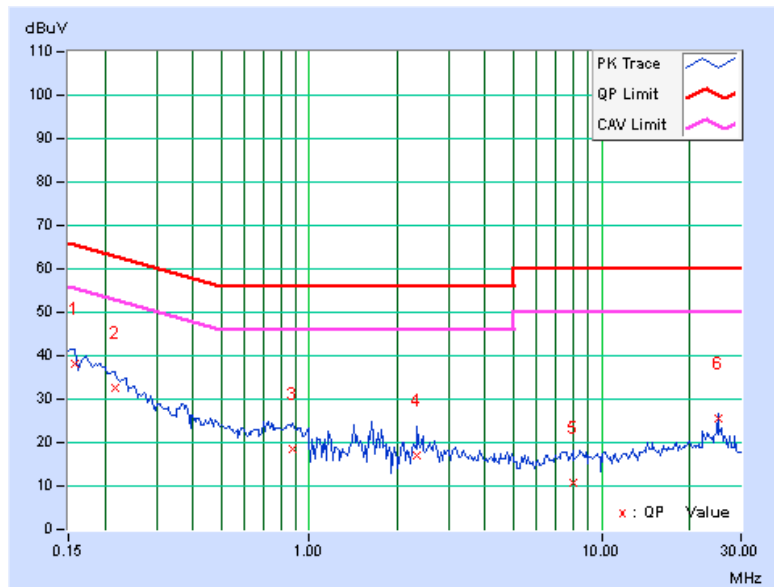

CONDUCTED WORST-CASE DATA :

FOR Zigbee

6dB BANDWIDTH	9kHz	PHASE	Line 1
----------------------	------	--------------	--------

No	Freq.	Corr.	Reading Value		Emission Level		Limit		Margin	
	[MHz]	Factor	[dB (uV)]		[dB (uV)]		[dB (uV)]		(dB)	
		(dB)	Q.P.	AV.	Q.P.	AV.	Q.P.	AV.	Q.P.	AV.
1	0.16172	0.15	32.04	15.12	32.19	15.27	65.38	55.38	-33.19	-40.11
2	0.36875	0.17	33.14	26.31	33.31	26.48	58.53	48.53	-25.22	-22.05
3	0.97813	0.19	21.16	10.22	21.35	10.41	56.00	46.00	-34.65	-35.59
4	1.71875	0.24	23.58	14.28	23.82	14.52	56.00	46.00	-32.18	-31.48
5	7.88281	0.40	15.25	10.26	15.65	10.66	60.00	50.00	-44.35	-39.34
6	22.72266	0.60	20.56	13.70	21.16	14.30	60.00	50.00	-38.84	-35.70

REMARKS:

1. Q.P. and AV. are abbreviations of quasi-peak and average individually.
2. The emission levels of other frequencies were very low against the limit.
3. Margin value = Emission level - Limit value
4. Correction factor = Insertion loss + Cable loss
5. Emission Level = Correction Factor + Reading Value.

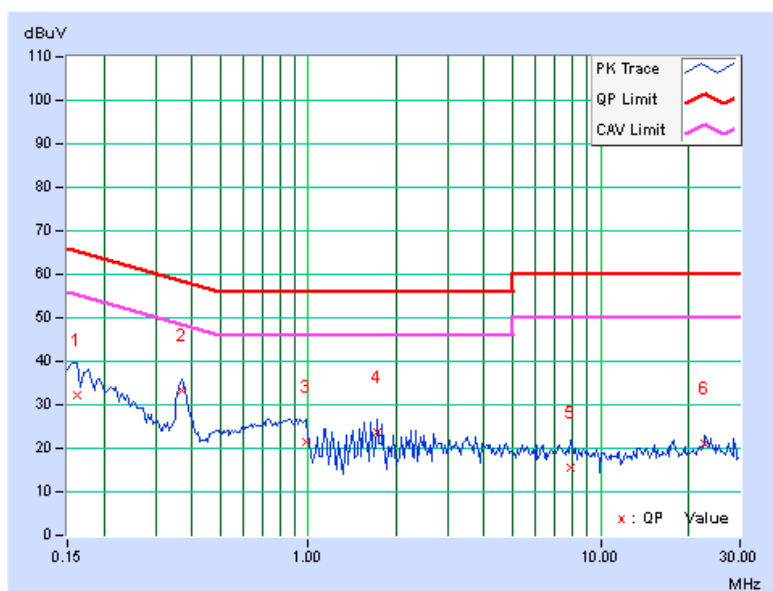



6dB BANDWIDTH	9kHz	PHASE	Line 2
---------------	------	-------	--------

No	Freq.	Corr.	Reading Value		Emission Level		Limit		Margin	
	[MHz]	Factor	[dB (uV)]		[dB (uV)]		[dB (uV)]		(dB)	
		(dB)	Q.P.	AV.	Q.P.	AV.	Q.P.	AV.	Q.P.	AV.
1	0.15781	0.13	36.16	20.45	36.29	20.58	65.58	55.58	-29.29	-35.00
2	0.18125	0.14	30.21	13.05	30.35	13.19	64.43	54.43	-34.08	-41.24
3	0.73203	0.18	19.41	10.96	19.59	11.14	56.00	46.00	-36.41	-34.86
4	2.18750	0.27	16.31	9.22	16.58	9.49	56.00	46.00	-39.42	-36.51
5	8.32422	0.44	10.12	0.87	10.56	1.31	60.00	50.00	-49.44	-48.69
6	25.19141	0.63	15.30	3.78	15.93	4.41	60.00	50.00	-44.07	-45.59

REMARKS:

1. Q.P. and AV. are abbreviations of quasi-peak and average individually.
2. The emission levels of other frequencies were very low against the limit.
3. Margin value = Emission level - Limit value
4. Correction factor = Insertion loss + Cable loss
5. Emission Level = Correction Factor + Reading Value.

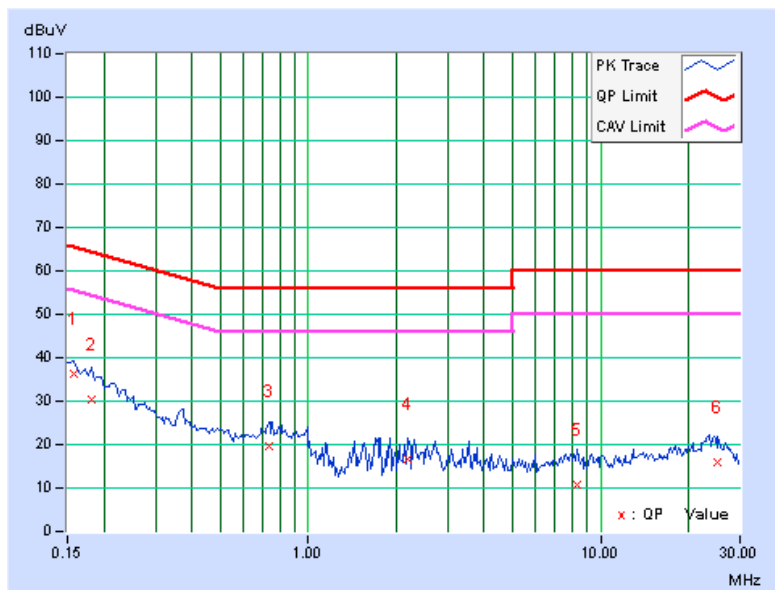



A D T

5. PHOTOGRAPHS OF THE TEST CONFIGURATION

Please refer to the attached file (Test Setup Photo).



A D T

6. INFORMATION ON THE TESTING LABORATORIES

We, Bureau Veritas Consumer Products Services (H.K.) Ltd., Taoyuan Branch, were founded in 1988 to provide our best service in EMC, Radio, Telecom and Safety consultation. Our laboratories are accredited and approved according to ISO/IEC 17025.

Copies of accreditation and authorization certificates of our laboratories obtained from approval agencies can be downloaded from our web site: www.adt.com.tw/index.5.phtml.

If you have any comments, please feel free to contact us at the following:

Linko EMC/RF Lab

Tel: 886-2-26052180

Fax: 886-2-26051924

Hsin Chu EMC/RF Lab

Tel: 886-3-5935343

Fax: 886-3-5935342

Hwa Ya EMC/RF/Safety/Telecom Lab

Tel: 886-3-3183232

Fax: 886-3-3270892

Email: service.adt@tw.bureauveritas.com

Web Site: www.adt.com.tw

The address and road map of all our labs can be found in our web site also.

7. APPENDIX A - MODIFICATIONS RECORDERS FOR ENGINEERING CHANGES TO THE EUT BY THE LAB

No any modifications are made to the EUT by the lab during the test.

--- END ---