

M3 尾翼

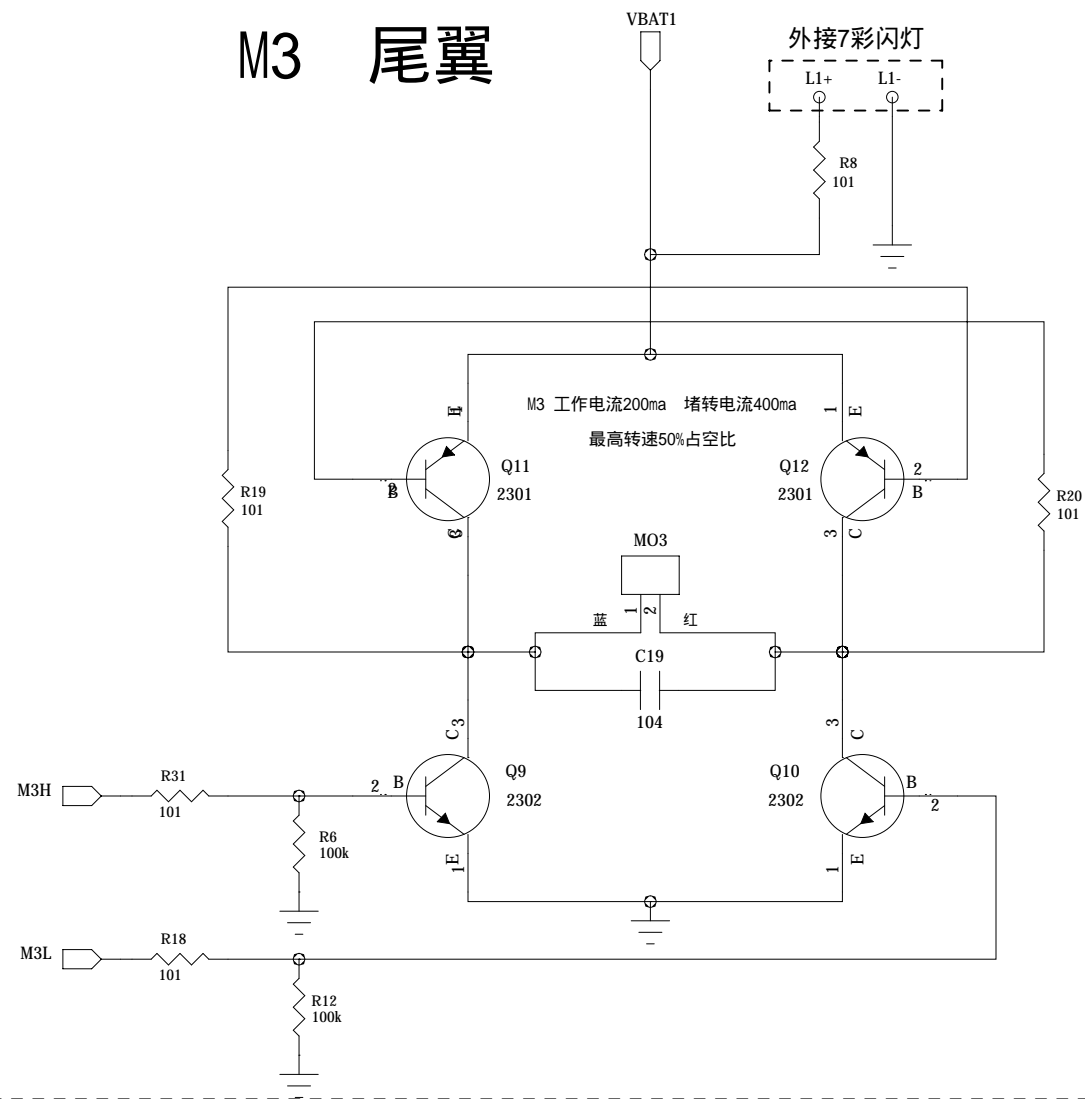

M1 上翼

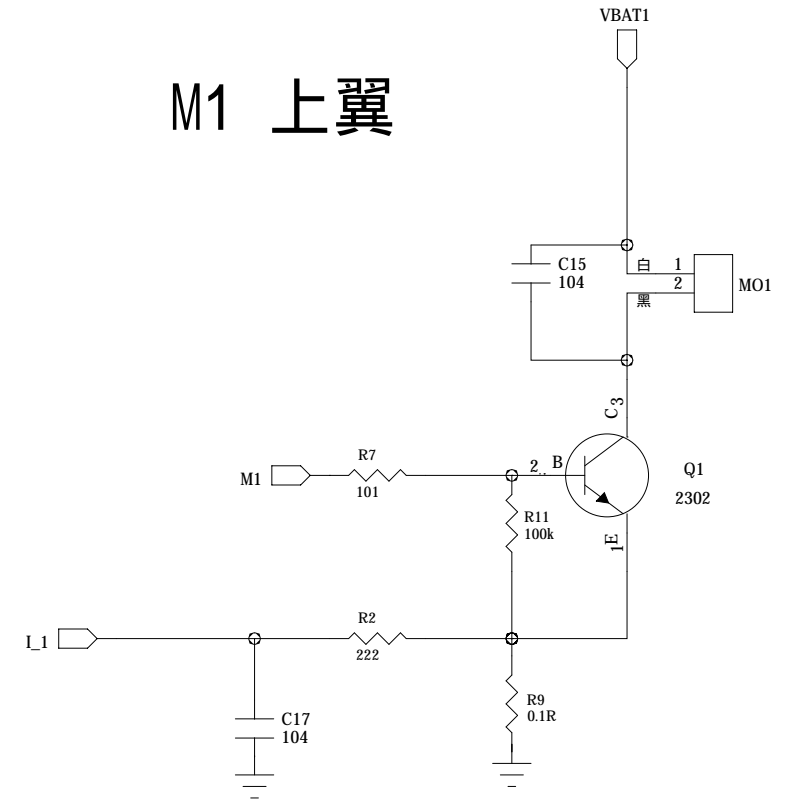

2.2A 过流保护

M2 下翼

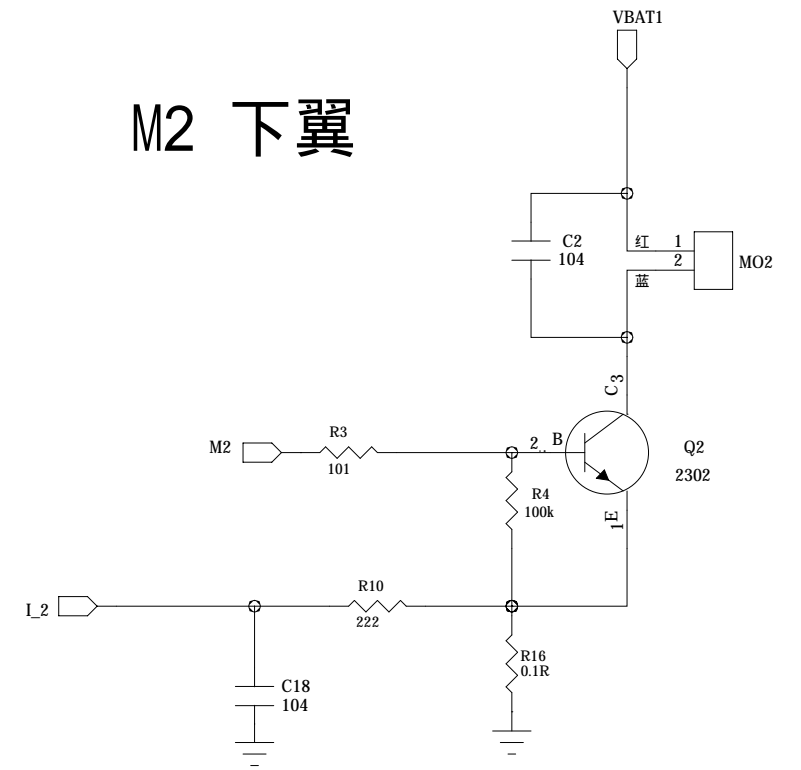

USB充电线已做充电限流处理

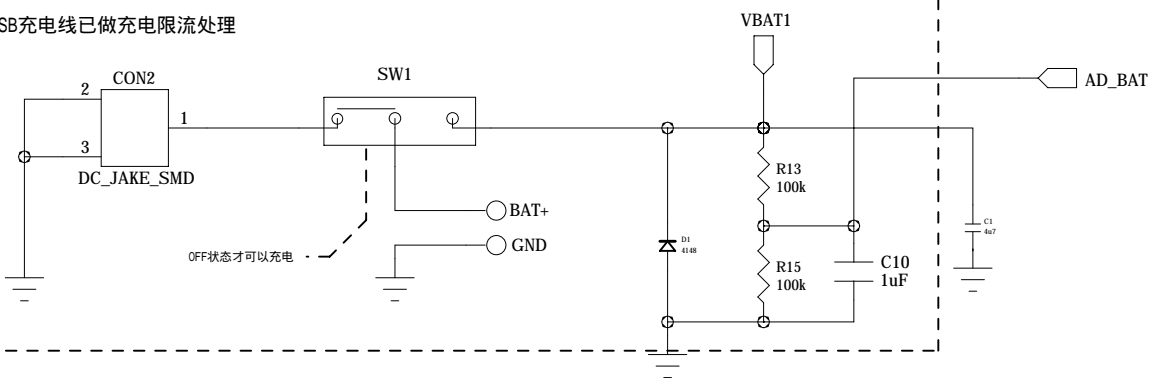

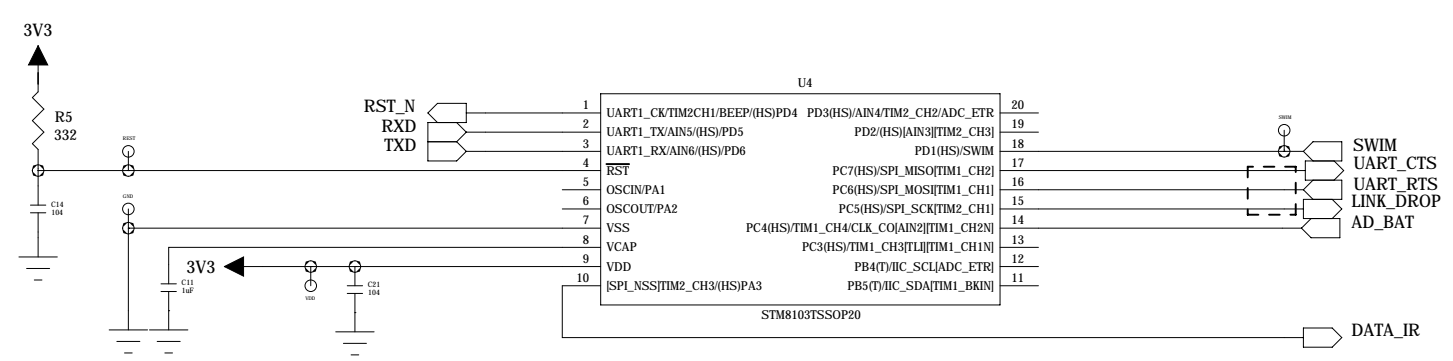
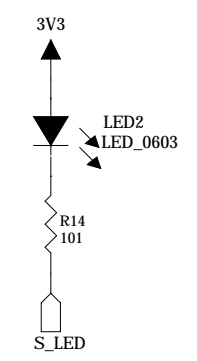
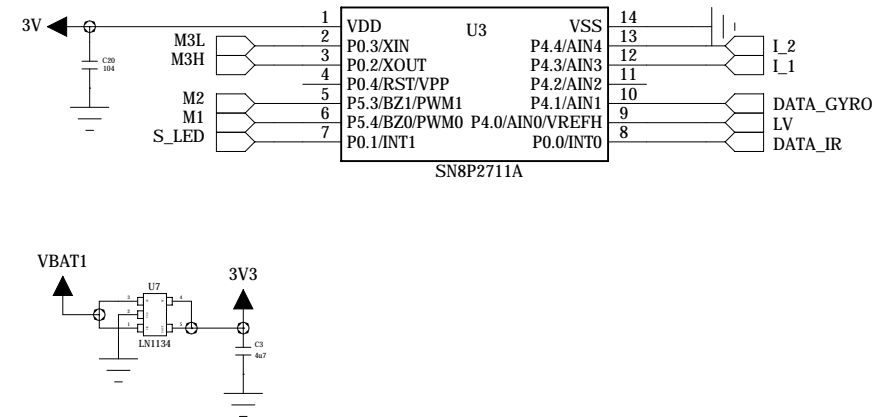
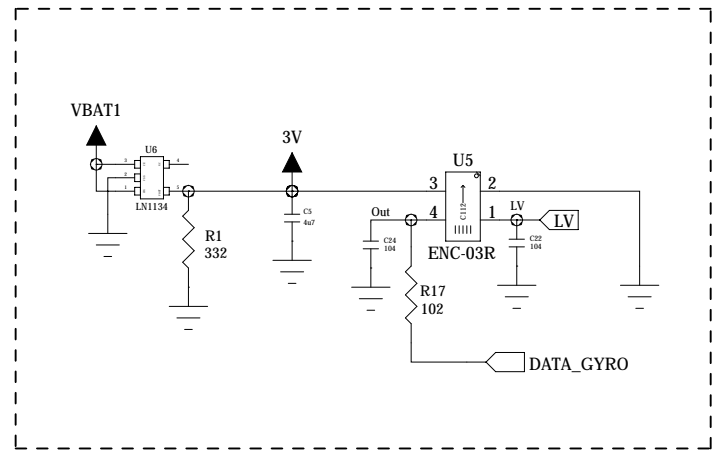

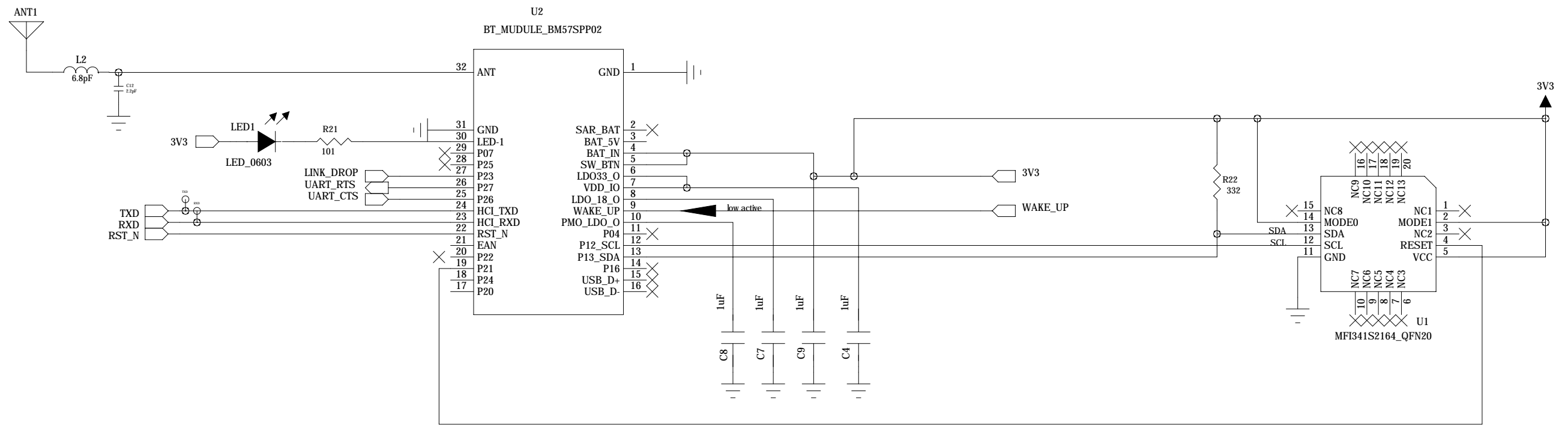

RF Module

