

## FCC Test Report

**Report No.:** RF141226E08

**FCC ID:** Z28AD1000

**Test Model:** AD1000-C

**Series Model:** AD1000-R, AD1000

**Received Date:** Dec. 26, 2014

**Test Date:** Jan. 14 to 15, 2015

**Issued Date:** Mar. 04, 2015

**Applicant:** ZUNIDATA SYSTEMS, INC.

**Address:** 4F-7, No.65, Gaotia 7th Rd, Zhubei City, Hsinchu county 302, Taiwan

**Issued By:** Bureau Veritas Consumer Products Services (H.K.) Ltd., Taoyuan Branch  
Hsin Chu Laboratory

**Lab Address:** No. 81-1, Lu Liao Keng, 9th Ling, Wu Lung Tsuen, Chiung Lin Hsiang, Hsin  
Chu Hsien 307, Taiwan R.O.C.

**Test Location (1):** No. 81-1, Lu Liao Keng, 9th Ling, Wu Lung Tsuen, Chiung Lin Hsiang, Hsin  
Chu Hsien 307, Taiwan R.O.C.

**Test Location (2):** No. 49, Ln. 206, Wende Rd., Shangshan Tsuen, Chiung Lin Hsiang, Hsin  
Chu Hsien 307, Taiwan R.O.C.



This report is for your exclusive use. Any copying or replication of this report to or for any other person or entity, or use of our name or trademark, is permitted only with our prior written permission. This report sets forth our findings solely with respect to the test samples identified herein. The results set forth in this report are not indicative or representative of the quality or characteristics of the lot from which a test sample was taken or any similar or identical product unless specifically and expressly noted. Our report includes all of the tests requested by you and the results thereof based upon the information that you provided to us. You have 60 days from date of issuance of this report to notify us of any material error or omission caused by our negligence, provided, however, that such notice shall be in writing and shall specifically address the issue you wish to raise. A failure to raise such issue within the prescribed time shall constitute your unqualified acceptance of the completeness of this report, the tests conducted and the correctness of the report contents. Unless specific mention, the uncertainty of measurement has been explicitly taken into account to declare the compliance or non-compliance to the specification. The report must not be used by the client to claim product certification, approval, or endorsement by TAF or any government agencies.

## Table of Contents

<b>Release Control Record</b> .....	<b>4</b>
<b>1 Certificate of Conformity</b> .....	<b>5</b>
<b>2 Summary of Test Results</b> .....	<b>6</b>
2.1 Measurement Uncertainty .....	6
2.2 Modification Record .....	6
<b>3 General Information</b> .....	<b>7</b>
3.1 General Description of EUT .....	7
3.2 Description of Test Modes .....	8
3.2.1 Test Mode Applicability and Tested Channel Detail.....	9
3.3 Duty Cycle of Test Signal .....	11
3.4 Description of Support Units .....	12
3.4.1 Configuration of System under Test .....	13
3.5 General Description of Applied Standards .....	14
<b>4 Test Types and Results</b> .....	<b>15</b>
4.1 Radiated Emission and Bandedge Measurement.....	15
4.1.1 Limits of Radiated Emission and Bandedge Measurement .....	15
4.1.2 Test Instruments .....	16
4.1.3 Test Procedures.....	18
4.1.4 Deviation from Test Standard .....	18
4.1.5 Test Set Up .....	19
4.1.6 EUT Operating Conditions.....	19
4.1.7 Test Results .....	20
4.2 Conducted Emission Measurement .....	30
4.2.1 Limits of Conducted Emission Measurement .....	30
4.2.2 Test Instruments .....	30
4.2.3 Test Procedures.....	31
4.2.4 Deviation from Test Standard .....	31
4.2.5 Test Setup.....	31
4.2.6 EUT Operating Conditions.....	31
4.2.7 Test Results .....	32
4.3 6dB Bandwidth Measurement.....	34
4.3.1 Limits of 6dB Bandwidth Measurement.....	34
4.3.2 Test Setup.....	34
4.3.3 Test Instruments .....	34
4.3.4 Test Procedure .....	34
4.3.5 Deviation from Test Standard .....	34
4.3.6 EUT Operating Conditions.....	34
4.3.7 Test Result.....	35
4.4 Conducted Output Power Measurement.....	37
4.4.1 Limits of Conducted Output Power Measurement .....	37
4.4.2 Test Setup.....	37
4.4.3 Test Instruments .....	37
4.4.4 Test Procedures.....	37
4.4.5 Deviation from Test Standard .....	37
4.4.6 EUT Operating Conditions.....	37
4.4.7 Test Results .....	38
4.5 Power Spectral Density Measurement.....	40
4.5.1 Limits of Power Spectral Density Measurement .....	40
4.5.2 Test Setup.....	40
4.5.3 Test Instruments .....	40
4.5.4 Test Procedure .....	40
4.5.5 Deviation from Test Standard .....	40
4.5.6 EUT Operating Condition .....	40



4.5.7 Test Results ..... 41

4.6 Conducted Out of Band Emission Measurement..... 43

4.6.1 Limits of Conducted Out of Band Emission Measurement ..... 43

4.6.2 Test Setup..... 43

4.6.3 Test Instruments ..... 43

4.6.4 Test Procedure ..... 43

4.6.5 Deviation from Test Standard ..... 43

4.6.6 EUT Operating Condition ..... 43

4.6.7 Test Results ..... 44

**5 Pictures of Test Arrangements..... 47**

**Appendix – Information on the Testing Laboratories ..... 48**



A D T

### Release Control Record

Issue No.	Description	Date Issued
RF141226E08	Original release.	Mar. 04, 2015



## 1 Certificate of Conformity

**Product:** POS system

**Brand:** Zunidata

**Test Model:** AD1000-C

**Series Model:** AD1000-R, AD1000

**Sample Status:** ENGINEERING SAMPLE

**Applicant:** ZUNIDATA SYSTEMS, INC.

**Test Date:** Jan. 14 to 15, 2015

**Standards:** 47 CFR FCC Part 15, Subpart C (Section 15.247)  
ANSI C63.10:2009

The above equipment has been tested by **Bureau Veritas Consumer Products Services (H.K.) Ltd., Taoyuan Branch**, and found compliance with the requirement of the above standards. The test record, data evaluation & Equipment Under Test (EUT) configurations represented herein are true and accurate accounts of the measurements of the sample's EMC characteristics under the conditions specified in this report.

**Prepared by :** , **Date:** Mar. 04, 2015  
Claire Kuan / Specialist

**Approved by :** , **Date:** Mar. 04, 2015  
May Chen / Manager

## 2 Summary of Test Results

47 CFR FCC Part 15, Subpart C (SECTION 15.247)			
FCC Clause	Test Item	Result	Remarks
15.207	AC Power Conducted Emission	PASS	Meet the requirement of limit. Minimum passing margin is -3.55dB at 0.40391MHz.
15.205 / 15.209 / 15.247(d)	Radiated Emissions and Band Edge Measurement	PASS	Meet the requirement of limit. Minimum passing margin is -0.2dB at 2483.50MHz.
15.247(d)	Antenna Port Emission	PASS	Meet the requirement of limit.
15.247(a)(2)	6dB bandwidth	PASS	Meet the requirement of limit.
15.247(b)	Conducted power	PASS	Meet the requirement of limit.
15.247(e)	Power Spectral Density	PASS	Meet the requirement of limit.
15.203	Antenna Requirement	PASS	Antenna connector is Reverse SMA Male not a standard connector.

### 2.1 Measurement Uncertainty

Where relevant, the following measurement uncertainty levels have been estimated for tests performed on the EUT as specified in CISPR 16-4-2:

Measurement	Frequency	Expanded Uncertainty (k=2) (±)
Conducted Emissions at mains ports	150kHz ~ 30MHz	2.86 dB
Radiated Emissions up to 1 GHz	30MHz ~ 1000MHz	5.43 dB
Radiated Emissions above 1 GHz	1GHz ~ 6GHz	3.65 dB
	6GHz ~ 18GHz	3.88 dB
	18GHz ~ 40GHz	4.11 dB

### 2.2 Modification Record

There were no modifications required for compliance.

### 3 General Information

#### 3.1 General Description of EUT

Product	POS system
Brand	Zunidata
Test Model	AD1000-C
Series Model	AD1000-R, AD1000
Status of EUT	ENGINEERING SAMPLE
Power Supply Rating	12Vdc from power adapter
Modulation Type	CCK, DQPSK, DBPSK for DSSS 256QAM, 64QAM, 16QAM, QPSK, BPSK for OFDM
Modulation Technology	DSSS, OFDM
Transfer Rate	802.11b: up to 11Mbps 802.11g: up to 54Mbps 802.11n: up to 72.2Mbps
Operating Frequency	2412 ~ 2462MHz
Number of Channel	11 for 802.11b, 802.11g, 802.11n (HT20)
Output Power	147.911mW
Antenna Type	Please see NOTE
Antenna Connector	Please see NOTE
Accessory Device	Adapter x 1 Micro SD Card (Brand: SanDisk , Model No.: SDSDQAB-004G) (Option) HDD (Brand: HITACHI , Model No.: HTS545032A7E380) (Option) VFD (Brand: Labau , Model No.: LD230) (Option) MSR module (Brand: gigatms , Model No.: MSR170HK-NT) (Option)
Data Cable Supplied	NA

**Note:**

- The EUT has below model names, which are identical to each other in all aspects except for the following information:

Brand Name	Model Name	Difference
Zunidata	AD1000-R	Resistance type panel
	AD1000-C	Capacitance type panel
	AD1000	Resistance type panel or Capacitance type panel

From the above models, model: **AD1000-C** was the worst case and it was selected as representative model for the test and its data was recorded in this report.

- The antenna provided to the EUT, please refer to the following table:

Brand	Model	Gain (dBi)	Antenna Type	Connector Type	Frequency range (GHz to GHz)
Walsin Technology Corporation	RFDPA151300SBAB8G1	3	Dipole	Reverse SMA Male	2.4 ~ 2.4835

- The EUT must be supplied with a power adapter as following table:

Brand	Model No.	Spec.
DVE	DSA-60PFB-12 1 120500	Input: 100-240Vac, 50/60Hz, 1.5A AC input cable: Unshielded, 1.8m Output: 12Vdc, 5A DC output cable: Unshielded, 1.4m

4. The EUT incorporates a SISO function.

Modulation Mode	Data Rate (MCS)	TX FUNCTION
802.11b	1 ~ 11Mbps	1TX
802.11g	6 ~ 54Mbps	1TX
802.11n (HT20)	MCS 0~7	1TX

5. The above EUT information is declared by manufacturer and for more detailed features description, please refer to the manufacturer's specifications or user's manual.

### 3.2 Description of Test Modes

11 channels are provided for 802.11b, 802.11g and 802.11n (HT20):

Channel	Frequency	Channel	Frequency
1	2412MHz	7	2442MHz
2	2417MHz	8	2447MHz
3	2422MHz	9	2452MHz
4	2427MHz	10	2457MHz
5	2432MHz	11	2462MHz
6	2437MHz		



### 3.2.1 Test Mode Applicability and Tested Channel Detail

EUT CONFIGURE MODE	APPLICABLE TO				DESCRIPTION
	PLC	RE < 1G	RE ≥ 1G	APCM	
-	√	√	√	√	-

Where **PLC:** Power Line Conducted Emission

**RE<1G:** Radiated Emission below 1GHz

**RE≥1G:** Radiated Emission above 1GHz

**APCM:** Antenna Port Conducted Measurement

**NOTE:** "-" means no effect.

#### Radiated Emission Test (Above 1GHz):

Pre-Scan has been conducted to determine the worst-case mode from all possible combinations between available modulations, data rates and antenna ports (if EUT with antenna diversity architecture).

Following channel(s) was (were) selected for the final test as listed below.

MODE	AVAILABLE CHANNEL	TESTED CHANNEL	MODULATION TECHNOLOGY	MODULATION TYPE	DATA RATE (Mbps)
802.11b	1 to 11	1, 6, 11	DSSS	DBPSK	1
802.11g	1 to 11	1, 6, 11	OFDM	BPSK	6
802.11n (HT20)	1 to 11	1, 6, 11	OFDM	BPSK	6.5

#### Radiated Emission Test (Below 1GHz):

Pre-Scan has been conducted to determine the worst-case mode from all possible combinations between available modulations, data rates and antenna ports (if EUT with antenna diversity architecture).

Following channel(s) was (were) selected for the final test as listed below.

MODE	AVAILABLE CHANNEL	TESTED CHANNEL	MODULATION TECHNOLOGY	MODULATION TYPE	DATA RATE (Mbps)
802.11g	1 to 11	6	OFDM	BPSK	6

#### Power Line Conducted Emission Test:

Pre-Scan has been conducted to determine the worst-case mode from all possible combinations between available modulations, data rates and antenna ports (if EUT with antenna diversity architecture).

Following channel(s) was (were) selected for the final test as listed below.

MODE	AVAILABLE CHANNEL	TESTED CHANNEL	MODULATION TECHNOLOGY	MODULATION TYPE	DATA RATE (Mbps)
802.11g	1 to 11	6	OFDM	BPSK	6

**Antenna Port Conducted Measurement:**

- This item includes all test value of each mode, but only includes spectrum plot of worst value of each mode.
- Pre-Scan has been conducted to determine the worst-case mode from all possible combinations between available modulations, data rates and antenna ports (if EUT with antenna diversity architecture).
- Following channel(s) was (were) selected for the final test as listed below.

MODE	AVAILABLE CHANNEL	TESTED CHANNEL	MODULATION TECHNOLOGY	MODULATION TYPE	DATA RATE (Mbps)
802.11b	1 to 11	1, 6, 11	DSSS	DBPSK	1
802.11g	1 to 11	1, 6, 11	OFDM	BPSK	6
802.11n (HT20)	1 to 11	1, 6, 11	OFDM	BPSK	6.5

**TEST CONDITION:**

APPLICABLE TO	ENVIRONMENTAL CONDITIONS	INPUT POWER	Tested by
RE $\geq$ 1G	25deg. C, 65%RH	120Vac, 60Hz	Andy Ho
RE<1G	25deg. C, 65%RH	120Vac, 60Hz	Andy Ho
PLC	25deg. C, 68%RH	120Vac, 60Hz	Barry Lee
APCM	21deg. C, 60%RH	120Vac, 60Hz	Robert Cheng

### 3.3 Duty Cycle of Test Signal

Duty cycle of test signal is 100 %, duty factor is not required.

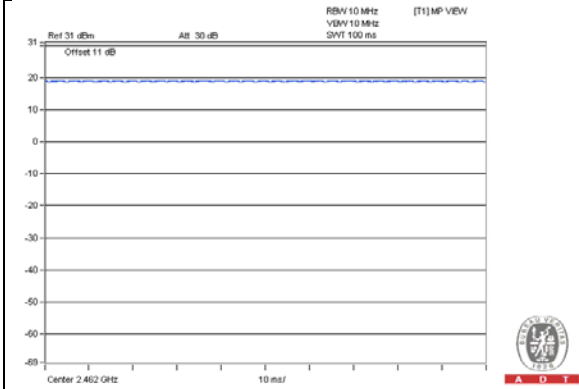
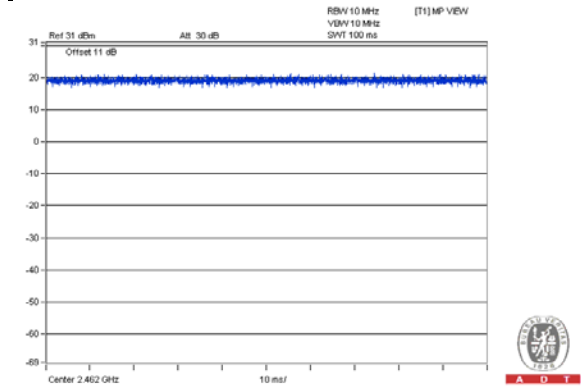
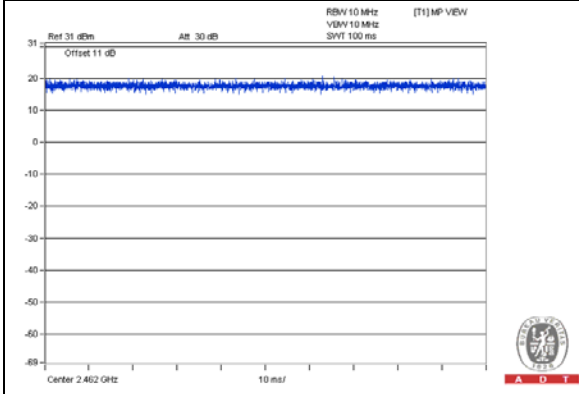
**802.11b****802.11g****802.11n (HT20)**

### 3.4 Description of Support Units

The EUT has been tested as an independent unit together with other necessary accessories or support units. The following support units or accessories were used to form a representative test configuration during the tests.

No.	Product	Brand	Model No.	Serial No.	FCC ID	Remark
A	MONITOR	DELL	NA	CN-0NN792-74261-849-15N4S	NA	Provided by Lab
B	KEYBOARD	DELL	SK-8115	MY-0J4635-71619-67V-0118	FCC DoC	Provided by Lab
C	MOUSE	DELL	M056UOA	FORO0BF9	FCC DoC	Provided by Lab
D	BARCODE SCANNER	GoDEX	GS220U	NA	NA	Supplied by Client
E	THERMAL PRINTER	WINPOS	WP-T810	NA	NA	Supplied by Client
F	CASH DRAWER	Labau	LD230	NA	NA	Supplied by Client
G	IPOD	Apple	MC749TA/A	CC4DN25WDFDM	NA	Provided by Lab
H	NOTEBOOK COMPUTER	DELL	PP32LA	GSLB32S	FCC DoC	Provided by Lab

**NOTE:**

- All power cords of the above support units are non-shielded (1.8 m).

No.	Cable	Qty.	Length (m)	Shielded (Yes/ No)	Cores (Number)	Remark
1	VGA	1	1.8	No	2	Provided by Lab
2	USB	1	1.8	Yes	1	Provided by Lab
3	USB	1	1.8	Yes	0	Provided by Lab
4	USB	1	1.8	Yes	0	Supplied by Client
5	PRINTER	1	1.8	No	0	Supplied by Client
6	DC	1	1.4	No	1	Supplied by Client
7	AC	1	1.8	No	0	Supplied by Client
8	RJ11	1	1	No	3	Supplied by Client
9	IPOD	1	0.1	No	0	Provided by Lab
10	LAN	1	10	No	0	Provided by Lab

Note: The core(s) is(are) originally attached to the cable(s).

### 3.4.1 Configuration of System under Test

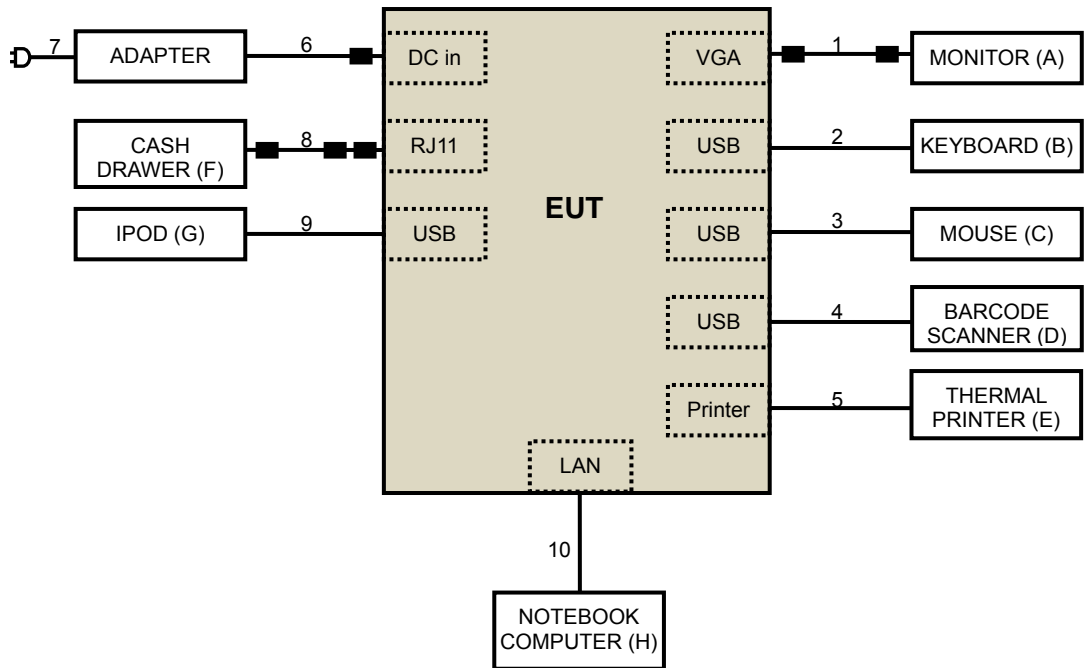

### 3.5 General Description of Applied Standards

The EUT is a RF Product. According to the specifications of the manufacturer, it must comply with the requirements of the following standards:

**FCC Part 15, Subpart C (15.247)**  
**558074 D01 DTS Meas Guidance v03r02**  
ANSI C63.10-2009

All test items have been performed and recorded as per the above standards.

**NOTE:** The EUT has been verified to comply with the requirements of FCC Part 15, Subpart B, Class B (DoC). The test report has been issued separately.

## 4 Test Types and Results

### 4.1 Radiated Emission and Bandedge Measurement

#### 4.1.1 Limits of Radiated Emission and Bandedge Measurement

Radiated emissions which fall in the restricted bands must comply with the radiated emission limits specified as below table. Other emissions shall be at least 20dB below the highest level of the desired power:

Frequencies (MHz)	Field Strength (microvolts/meter)	Measurement Distance (meters)
0.009 ~ 0.490	2400/F(kHz)	300
0.490 ~ 1.705	24000/F(kHz)	30
1.705 ~ 30.0	30	30
30 ~ 88	100	3
88 ~ 216	150	3
216 ~ 960	200	3
Above 960	500	3

**NOTE:**

1. The lower limit shall apply at the transition frequencies.
2. Emission level (dBuV/m) = 20 log Emission level (uV/m).
3. For frequencies above 1000MHz, the field strength limits are based on average detector, however, the peak field strength of any emission shall not exceed the maximum permitted average limits, specified above by more than 20dB under any condition of modulation.

**4.1.2 Test Instruments**
**For below 1GHz:**

DESCRIPTION & MANUFACTURER	MODEL NO.	SERIAL NO.	CALIBRATED DATE	CALIBRATED UNTIL
MXE EMI Receiver Agilent	N9038A	MY50010156	Aug. 11, 2014	Aug. 10, 2015
Pre-Amplifier Mini-Circuits	ZFL-1000VH2 B	AMP-ZFL-04	Nov. 12, 2014	Nov. 11, 2015
Trilog Broadband Antenna SCHWARZBECK	VULB 9168	9168-361	Feb. 27, 2014	Feb. 26, 2015
RF Cable	NA	CHHCAB_001	Oct. 05, 2014	Oct. 04, 2015
Horn_Antenna AISI	AIH.8018	0000220091110	Aug. 26, 2014	Aug. 25, 2015
Pre-Amplifier Agilent	8449B	300801923	Oct. 28, 2014	Oct. 27, 2015
RF Cable	NA	131206 131215 SNMY23685/4	Jan. 17, 2014	Jan. 16, 2015
Spectrum Analyzer R&S	FSV40	100964	July 05, 2014	July 04, 2015
Pre-Amplifier EMCI	EMC184045	980143	Jan. 17, 2014	Jan. 16, 2015
Horn_Antenna SCHWARZBECK	BBHA 9170	9170-424	Aug. 26, 2014	Aug. 25, 2015
RF Cable	NA	RF104-121 RF104-204	Dec. 11, 2014	Dec. 10, 2015
Software	ADT_Radiated _V8.7.07	NA	NA	NA
Antenna Tower & Turn Table CT	NA	NA	NA	NA

**Note:**

1. The calibration interval of the above test instruments is 12 months and the calibrations are traceable to NML/ROC and NIST/USA.
2. The horn antenna, preamplifier (model: 8449B) are used only for the measurement of emission frequency above 1GHz if tested.
3. The test was performed in 966 Chamber No. H.
4. The FCC Site Registration No. is 797305.
5. The CANADA Site Registration No. is IC 7450H-3.
6. Tested Date: Jan. 14, 2015



**For above 1GHz:**

DESCRIPTION & MANUFACTURER	MODEL NO.	SERIAL NO.	CALIBRATED DATE	CALIBRATED UNTIL
MXE EMI Receiver Agilent	N9038A	MY51210105	July 21, 2014	July 20, 2015
Pre-Amplifier Mini-Circuits	ZFL-1000VH2 B	AMP-ZFL-03	Nov. 12, 2014	Nov. 11, 2015
Trilog Broadband Antenna SCHWARZBECK	VULB 9168	9168-360	Feb. 26, 2014	Feb. 25, 2015
RF Cable	NA	CHGCAB_001	Oct. 04, 2014	Oct. 03, 2015
Horn_Antenna AISI	AIH.8018	0000320091110	Aug. 27, 2014	Aug. 26, 2015
Pre-Amplifier Agilent	8449B	3008A02578	June 24, 2014	June 23, 2015
RF Cable	NA	131205 131214 SNMY23684/4	Jan. 17, 2014	Jan. 16, 2015
Spectrum Analyzer R&S	FSV40	100964	July 05, 2014	July 04, 2015
Pre-Amplifier EMCI	EMC184045	980143	Jan. 17, 2014	Jan. 16, 2015
Horn_Antenna SCHWARZBECK	BBHA 9170	9170-424	Aug. 26, 2014	Aug. 25, 2015
RF Cable	NA	RF104-121 RF104-204	Dec. 11, 2014	Dec. 10, 2015
Antenna Tower & Turn Table CT	NA	NA	NA	NA

**Note:**

1. The calibration interval of the above test instruments is 12 months and the calibrations are traceable to NML/ROC and NIST/USA.
2. The horn antenna, preamplifier (model: 8449B) are used only for the measurement of emission frequency above 1GHz if tested.
3. The test was performed in 966 Chamber No. G.
4. The FCC Site Registration No. is 966073.
5. The VCCI Site Registration No. is G-137.
6. The CANADA Site Registration No. is IC 7450H-2.
7. Tested Date: Jan. 14, 2015

#### 4.1.3 Test Procedures

- a. The EUT was placed on the top of a rotating table 0.8 meters above the ground at 3 meter chamber room for test. The table was rotated 360 degrees to determine the position of the highest radiation.
- b. The EUT was set 3 meters away from the interference-receiving antenna, which was mounted on the top of a variable-height antenna tower.
- c. The height of antenna is varied from one meter to four meters above the ground to determine the maximum value of the field strength. Both horizontal and vertical polarizations of the antenna are set to make the measurement.
- d. For each suspected emission, the EUT was arranged to its worst case and then the antenna was tuned to heights from 1 meter to 4 meters and the rotatable table was turned from 0 degrees to 360 degrees to find the maximum reading.
- e. The test-receiver system was set to quasi-peak detect function and specified bandwidth with maximum hold mode when the test frequency is below 1 GHz.
- f. The test-receiver system was set to peak and average detect function and specified bandwidth with maximum hold mode when the test frequency is above 1 GHz. If the peak reading value also meets average limit, measurement with the average detector is unnecessary.

#### Note:

1. The resolution bandwidth and video bandwidth of test receiver/spectrum analyzer is 120kHz for Quasi-peak detection (QP) at frequency below 1GHz.
2. The resolution bandwidth of test receiver/spectrum analyzer is 1 MHz and the video bandwidth is 3 MHz for Peak detection (PK) at frequency above 1GHz.
3. The resolution bandwidth of test receiver/spectrum analyzer is 1MHz and the video bandwidth is 3MHz for RMS Average (Duty cycle < 98%) for Average detection (AV) at frequency above 1GHz, then the measurement results was added to a correction factor ( $10 \log(1/\text{duty cycle})$ ).
4. The resolution bandwidth of test receiver/spectrum analyzer is 1MHz and the video bandwidth is 10Hz (Duty cycle  $\geq 98\%$ ) for Average detection (AV) at frequency above 1GHz.
5. All modes of operation were investigated and the worst-case emissions are reported.

#### 4.1.4 Deviation from Test Standard

No deviation.

4.1.5 Test Set Up

**<Frequency Range below 1GHz>**

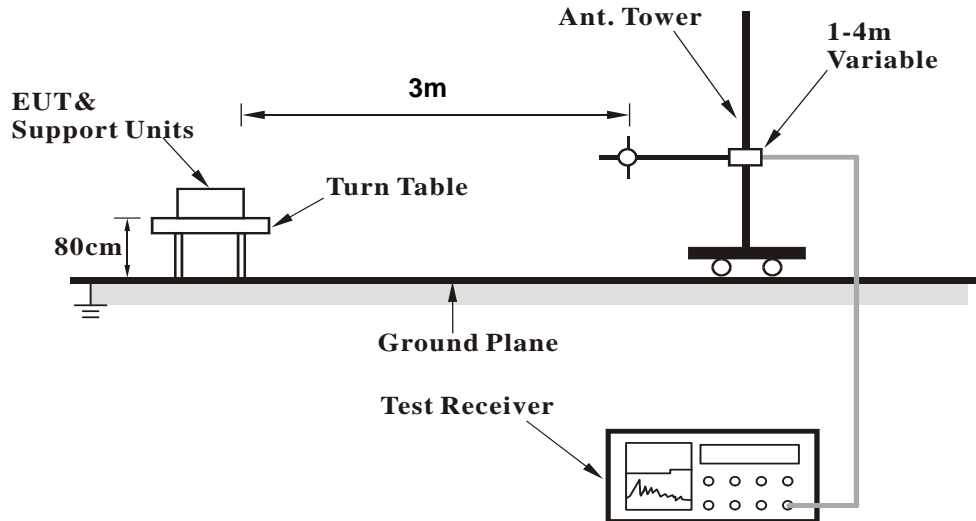

**<Frequency Range above 1GHz>**

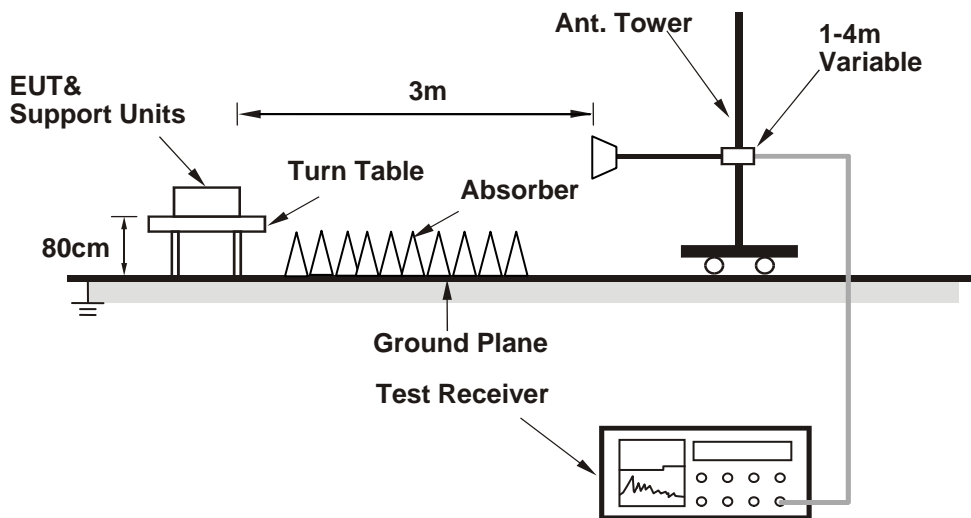

For the actual test configuration, please refer to the attached file (Test Setup Photo).

4.1.6 EUT Operating Conditions

1. Placed the EUT on testing table.
2. Controlling software (SET command.txt) has been activated to set the EUT under transmission/receiving condition continuously.

4.1.7 Test Results

**BELOW 1GHz WORST-CASE DATA**

**802.11g**

<b>CHANNEL</b>	TX Channel 6	<b>DETECTOR FUNCTION</b>	Quasi-Peak (QP)
<b>FREQUENCY RANGE</b>	30MHz ~ 1GHz		

**ANTENNA POLARITY & TEST DISTANCE: HORIZONTAL AT 3 M**

NO.	FREQ. (MHz)	EMISSION LEVEL (dBUV/m)	LIMIT (dBUV/m)	MARGIN (dB)	ANTENNA HEIGHT (m)	TABLE ANGLE (Degree)	RAW VALUE (dBUV)	CORRECTION FACTOR (dB/m)
1	136.02	37.7 QP	43.5	-5.8	2.00 H	55	51.35	-13.66
2	149.17	32.5 QP	43.5	-11.0	1.50 H	297	45.40	-12.89
3	163.57	33.4 QP	43.5	-10.2	2.00 H	285	46.45	-13.10
4	250.00	39.9 QP	46.0	-6.1	1.00 H	256	53.81	-13.91
5	278.18	34.3 QP	46.0	-11.8	1.00 H	23	46.96	-12.71
6	1000.00	38.6 QP	54.0	-15.4	2.00 H	115	37.01	1.63

**ANTENNA POLARITY & TEST DISTANCE: VERTICAL AT 3 M**

NO.	FREQ. (MHz)	EMISSION LEVEL (dBUV/m)	LIMIT (dBUV/m)	MARGIN (dB)	ANTENNA HEIGHT (m)	TABLE ANGLE (Degree)	RAW VALUE (dBUV)	CORRECTION FACTOR (dB/m)
1	75.20	35.5 QP	40.0	-4.5	1.00 V	237	52.12	-16.62
2	108.00	32.2 QP	43.5	-11.3	1.00 V	78	48.35	-16.18
3	149.90	34.5 QP	43.5	-9.0	1.00 V	160	47.39	-12.86
4	280.02	34.6 QP	46.0	-11.4	1.50 V	4	47.25	-12.62
5	614.00	34.7 QP	46.0	-11.3	1.00 V	42	39.15	-4.49
6	1000.00	39.3 QP	54.0	-14.7	1.00 V	340	37.65	1.63

**ABOVE 1GHz DATA**

**802.11b**

<b>CHANNEL</b>	TX Channel 1	<b>DETECTOR FUNCTION</b>	Peak (PK)
<b>FREQUENCY RANGE</b>	1GHz ~ 25GHz		Average (AV)

**ANTENNA POLARITY & TEST DISTANCE: HORIZONTAL AT 3 M**

NO.	FREQ. (MHz)	EMISSION LEVEL (dBuV/m)	LIMIT (dBuV/m)	MARGIN (dB)	ANTENNA HEIGHT (m)	TABLE ANGLE (Degree)	RAW VALUE (dBuV)	CORRECTION FACTOR (dB/m)
1	2390.00	50.9 PK	74.0	-23.1	1.52 H	57	23.21	27.69
2	2390.00	42.8 AV	54.0	-11.2	1.52 H	57	15.11	27.69
3	*2412.00	97.8 PK			1.52 H	57	70.05	27.75
4	*2412.00	94.9 AV			1.52 H	57	67.15	27.75
5	4824.00	53.5 PK	74.0	-20.5	1.58 H	201	20.36	33.14
6	4824.00	49.2 AV	54.0	-4.8	1.58 H	201	16.06	33.14

**ANTENNA POLARITY & TEST DISTANCE: VERTICAL AT 3 M**

NO.	FREQ. (MHz)	EMISSION LEVEL (dBuV/m)	LIMIT (dBuV/m)	MARGIN (dB)	ANTENNA HEIGHT (m)	TABLE ANGLE (Degree)	RAW VALUE (dBuV)	CORRECTION FACTOR (dB/m)
1	2390.00	59.1 PK	74.0	-14.9	1.68 V	57	31.41	27.69
2	2390.00	53.5 AV	54.0	-0.5	1.68 V	57	25.81	27.69
3	*2412.00	108.4 PK			1.54 V	298	80.65	27.75
4	*2412.00	105.5 AV			1.54 V	298	77.75	27.75
5	4824.00	56.0 PK	74.0	-18.0	1.86 V	89	22.86	33.14
6	4824.00	53.2 AV	54.0	-0.8	1.86 V	89	20.06	33.14

**REMARKS:**

1. Emission Level(dBuV/m) = Raw Value(dBuV) + Correction Factor(dB/m)
2. Correction Factor(dB/m) = Antenna Factor(dB/m) + Cable Factor(dB) – Pre-Amplifier Factor(dB)
3. The other emission levels were very low against the limit.
4. Margin value = Emission Level – Limit value
5. " \* ": Fundamental frequency.

<b>CHANNEL</b>	TX Channel 6	<b>DETECTOR FUNCTION</b>	Peak (PK)
<b>FREQUENCY RANGE</b>	1GHz ~ 25GHz		Average (AV)

**ANTENNA POLARITY & TEST DISTANCE: HORIZONTAL AT 3 M**

NO.	FREQ. (MHz)	EMISSION LEVEL (dBuV/m)	LIMIT (dBuV/m)	MARGIN (dB)	ANTENNA HEIGHT (m)	TABLE ANGLE (Degree)	RAW VALUE (dBuV)	CORRECTION FACTOR (dB/m)
1	2385.00	48.4 PK	74.0	-25.6	1.56 H	242	20.72	27.68
2	2385.00	38.8 AV	54.0	-15.2	1.56 H	242	11.12	27.68
3	*2437.00	99.9 PK			1.56 H	242	72.08	27.82
4	*2437.00	97.1 AV			1.56 H	242	69.28	27.82
5	2488.90	42.5 PK	74.0	-31.5	1.56 H	242	14.53	27.97
6	2488.90	32.6 AV	54.0	-21.4	1.56 H	242	4.63	27.97
7	4874.00	49.3 PK	74.0	-24.7	1.54 H	124	16.03	33.27
8	4874.00	44.7 AV	54.0	-9.3	1.54 H	124	11.43	33.27
9	7311.00	50.7 PK	74.0	-23.3	1.50 H	154	11.39	39.31
10	7311.00	37.5 AV	54.0	-16.5	1.50 H	154	-1.81	39.31

**ANTENNA POLARITY & TEST DISTANCE: VERTICAL AT 3 M**

NO.	FREQ. (MHz)	EMISSION LEVEL (dBuV/m)	LIMIT (dBuV/m)	MARGIN (dB)	ANTENNA HEIGHT (m)	TABLE ANGLE (Degree)	RAW VALUE (dBuV)	CORRECTION FACTOR (dB/m)
1	2385.00	56.4 PK	74.0	-17.6	1.40 V	296	28.72	27.68
2	2385.00	46.8 AV	54.0	-7.2	1.40 V	296	19.12	27.68
3	*2437.00	109.9 PK			1.60 V	293	82.08	27.82
4	*2437.00	107.1 AV			1.60 V	293	79.28	27.82
5	2488.90	52.0 PK	74.0	-22.0	1.52 V	338	24.03	27.97
6	2488.90	41.8 AV	54.0	-12.2	1.52 V	338	13.83	27.97
7	4874.00	52.3 PK	74.0	-21.7	1.50 V	211	19.03	33.27
8	4874.00	47.7 AV	54.0	-6.3	1.50 V	211	14.43	33.27
9	7311.00	53.7 PK	74.0	-20.3	1.52 V	123	14.39	39.31
10	7311.00	40.0 AV	54.0	-14.0	1.52 V	123	0.69	39.31

**REMARKS:**

1. Emission Level(dBuV/m) = Raw Value(dBuV) + Correction Factor(dB/m)
2. Correction Factor(dB/m) = Antenna Factor(dB/m) + Cable Factor(dB) – Pre-Amplifier Factor(dB)
3. The other emission levels were very low against the limit.
4. Margin value = Emission Level – Limit value
5. " \* " : Fundamental frequency.

<b>CHANNEL</b>	TX Channel 11	<b>DETECTOR FUNCTION</b>	Peak (PK)
<b>FREQUENCY RANGE</b>	1GHz ~ 25GHz		Average (AV)

**ANTENNA POLARITY & TEST DISTANCE: HORIZONTAL AT 3 M**

NO.	FREQ. (MHz)	EMISSION LEVEL (dBuV/m)	LIMIT (dBuV/m)	MARGIN (dB)	ANTENNA HEIGHT (m)	TABLE ANGLE (Degree)	RAW VALUE (dBuV)	CORRECTION FACTOR (dB/m)
1	2382.00	48.5 PK	74.0	-25.5	1.52 H	324	20.83	27.67
2	2382.00	38.3 AV	54.0	-15.7	1.52 H	324	10.63	27.67
3	*2462.00	100.2 PK			1.52 H	324	72.31	27.89
4	*2462.00	97.2 AV			1.52 H	324	69.31	27.89
5	2483.50	50.7 PK	74.0	-23.3	1.52 H	324	22.75	27.95
6	2483.50	42.8 AV	54.0	-11.2	1.52 H	324	14.85	27.95
7	4924.00	60.1 PK	74.0	-13.9	1.50 H	123	26.70	33.40
8	4924.00	44.6 AV	54.0	-9.4	1.50 H	123	11.20	33.40
9	7386.00	52.1 PK	74.0	-21.9	1.55 H	158	12.83	39.27
10	7386.00	40.4 AV	54.0	-13.6	1.55 H	158	1.13	39.27

**ANTENNA POLARITY & TEST DISTANCE: VERTICAL AT 3 M**

NO.	FREQ. (MHz)	EMISSION LEVEL (dBuV/m)	LIMIT (dBuV/m)	MARGIN (dB)	ANTENNA HEIGHT (m)	TABLE ANGLE (Degree)	RAW VALUE (dBuV)	CORRECTION FACTOR (dB/m)
1	*2462.00	109.0 PK			1.85 V	349	81.11	27.89
2	*2462.00	106.2 AV			1.85 V	349	78.31	27.89
3	4924.00	51.6 PK	74.0	-22.4	1.72 V	213	18.20	33.40
4	4924.00	47.0 AV	54.0	-7.0	1.72 V	213	13.60	33.40
5	7386.00	53.4 PK	74.0	-20.6	1.50 V	221	14.13	39.27
6	7386.00	40.7 AV	54.0	-13.3	1.50 V	221	1.43	39.27

**REMARKS:**

1. Emission Level(dBuV/m) = Raw Value(dBuV) + Correction Factor(dB/m)
2. Correction Factor(dB/m) = Antenna Factor(dB/m) + Cable Factor(dB) – Pre-Amplifier Factor(dB)
3. The other emission levels were very low against the limit.
4. Margin value = Emission Level – Limit value
5. " \* ": Fundamental frequency.

802.11g

<b>CHANNEL</b>	TX Channel 1	<b>DETECTOR FUNCTION</b>	Peak (PK)
<b>FREQUENCY RANGE</b>	1GHz ~ 25GHz		Average (AV)

**ANTENNA POLARITY & TEST DISTANCE: HORIZONTAL AT 3 M**

NO.	FREQ. (MHz)	EMISSION LEVEL (dBuV/m)	LIMIT (dBuV/m)	MARGIN (dB)	ANTENNA HEIGHT (m)	TABLE ANGLE (Degree)	RAW VALUE (dBuV)	CORRECTION FACTOR (dB/m)
1	2390.00	66.2 PK	74.0	-7.8	1.66 H	63	38.51	27.69
2	2390.00	43.2 AV	54.0	-10.8	1.66 H	63	15.51	27.69
3	*2412.00	96.5 PK			1.66 H	63	68.75	27.75
4	*2412.00	88.6 AV			1.66 H	63	60.85	27.75
5	4824.00	53.5 PK	74.0	-20.5	1.54 H	186	20.36	33.14
6	4824.00	49.7 AV	54.0	-4.3	1.54 H	186	16.56	33.14

**ANTENNA POLARITY & TEST DISTANCE: VERTICAL AT 3 M**

NO.	FREQ. (MHz)	EMISSION LEVEL (dBuV/m)	LIMIT (dBuV/m)	MARGIN (dB)	ANTENNA HEIGHT (m)	TABLE ANGLE (Degree)	RAW VALUE (dBuV)	CORRECTION FACTOR (dB/m)
1	2390.00	73.0 PK	74.0	-1.0	2.08 V	360	45.31	27.69
2	2390.00	51.2 AV	54.0	-2.8	2.08 V	360	23.51	27.69
3	*2412.00	106.0 PK			2.08 V	360	78.25	27.75
4	*2412.00	96.0 AV			2.08 V	360	68.25	27.75
5	4824.00	56.0 PK	74.0	-18.0	1.88 V	95	22.86	33.14
6	4824.00	53.3 AV	54.0	-0.7	1.88 V	95	20.16	33.14

**REMARKS:**

1. Emission Level(dBuV/m) = Raw Value(dBuV) + Correction Factor(dB/m)
2. Correction Factor(dB/m) = Antenna Factor(dB/m) + Cable Factor(dB) – Pre-Amplifier Factor(dB)
3. The other emission levels were very low against the limit.
4. Margin value = Emission Level – Limit value
5. " \* ": Fundamental frequency.



<b>CHANNEL</b>	TX Channel 6	<b>DETECTOR FUNCTION</b>	Peak (PK)
<b>FREQUENCY RANGE</b>	1GHz ~ 25GHz		Average (AV)

**ANTENNA POLARITY & TEST DISTANCE: HORIZONTAL AT 3 M**

NO.	FREQ. (MHz)	EMISSION LEVEL (dBuV/m)	LIMIT (dBuV/m)	MARGIN (dB)	ANTENNA HEIGHT (m)	TABLE ANGLE (Degree)	RAW VALUE (dBuV)	CORRECTION FACTOR (dB/m)
1	2390.00	52.7 PK	74.0	-21.3	1.54 H	239	25.01	27.69
2	2390.00	37.3 AV	54.0	-16.7	1.54 H	239	9.61	27.69
3	*2437.00	101.5 PK			1.54 H	239	73.68	27.82
4	*2437.00	92.5 AV			1.54 H	239	64.68	27.82
5	2483.50	47.7 PK	74.0	-26.3	1.54 H	239	19.75	27.95
6	2483.50	33.6 AV	54.0	-20.4	1.54 H	239	5.65	27.95
7	4874.00	49.4 PK	74.0	-24.6	1.51 H	137	16.13	33.27
8	4874.00	44.8 AV	54.0	-9.2	1.51 H	137	11.53	33.27
9	7311.00	51.3 PK	74.0	-22.7	1.55 H	150	11.99	39.31
10	7311.00	37.0 AV	54.0	-17.0	1.55 H	150	-2.31	39.31

**ANTENNA POLARITY & TEST DISTANCE: VERTICAL AT 3 M**

NO.	FREQ. (MHz)	EMISSION LEVEL (dBuV/m)	LIMIT (dBuV/m)	MARGIN (dB)	ANTENNA HEIGHT (m)	TABLE ANGLE (Degree)	RAW VALUE (dBuV)	CORRECTION FACTOR (dB/m)
1	2390.00	59.0 PK	74.0	-15.0	2.04 V	360	31.31	27.69
2	2390.00	45.3 AV	54.0	-8.7	2.04 V	360	17.61	27.69
3	*2437.00	111.5 PK			2.04 V	360	83.68	27.82
4	*2437.00	101.0 AV			2.04 V	360	73.18	27.82
5	2483.50	55.7 PK	74.0	-18.3	2.04 V	360	27.75	27.95
6	2483.50	41.6 AV	54.0	-12.4	2.04 V	360	13.65	27.95
7	4874.00	52.4 PK	74.0	-21.6	1.49 V	200	19.13	33.27
8	4874.00	47.8 AV	54.0	-6.2	1.49 V	200	14.53	33.27
9	7311.00	54.3 PK	74.0	-19.7	1.53 V	116	14.99	39.31
10	7311.00	40.4 AV	54.0	-13.6	1.53 V	116	1.09	39.31

**REMARKS:**

1. Emission Level(dBuV/m) = Raw Value(dBuV) + Correction Factor(dB/m)
2. Correction Factor(dB/m) = Antenna Factor(dB/m) + Cable Factor(dB) – Pre-Amplifier Factor(dB)
3. The other emission levels were very low against the limit.
4. Margin value = Emission Level – Limit value
5. " \* ": Fundamental frequency.

<b>CHANNEL</b>	TX Channel 11	<b>DETECTOR FUNCTION</b>	Peak (PK)
<b>FREQUENCY RANGE</b>	1GHz ~ 25GHz		Average (AV)

**ANTENNA POLARITY & TEST DISTANCE: HORIZONTAL AT 3 M**

NO.	FREQ. (MHz)	EMISSION LEVEL (dBuV/m)	LIMIT (dBuV/m)	MARGIN (dB)	ANTENNA HEIGHT (m)	TABLE ANGLE (Degree)	RAW VALUE (dBuV)	CORRECTION FACTOR (dB/m)
1	*2462.00	100.6 PK			1.57 H	328	72.71	27.89
2	*2462.00	90.2 AV			1.57 H	328	62.31	27.89
3	2483.50	65.4 PK	74.0	-8.6	1.57 H	328	37.45	27.95
4	2483.50	45.5 AV	54.0	-8.5	1.57 H	328	17.55	27.95
5	4924.00	47.8 PK	74.0	-26.2	1.50 H	127	14.40	33.40
6	4924.00	43.5 AV	54.0	-10.5	1.50 H	127	10.10	33.40
7	7386.00	50.3 PK	74.0	-23.7	1.51 H	328	11.03	39.27
8	7386.00	37.6 AV	54.0	-16.4	1.51 H	328	-1.67	39.27

**ANTENNA POLARITY & TEST DISTANCE: VERTICAL AT 3 M**

NO.	FREQ. (MHz)	EMISSION LEVEL (dBuV/m)	LIMIT (dBuV/m)	MARGIN (dB)	ANTENNA HEIGHT (m)	TABLE ANGLE (Degree)	RAW VALUE (dBuV)	CORRECTION FACTOR (dB/m)
1	*2462.00	110.6 PK			1.77 V	360	82.71	27.89
2	*2462.00	99.1 AV			1.77 V	360	71.21	27.89
3	2483.50	73.4 PK	74.0	-0.6	1.77 V	360	45.45	27.95
4	2483.50	53.5 AV	54.0	-0.5	1.77 V	360	25.55	27.95
5	4924.00	50.8 PK	74.0	-23.2	1.74 V	206	17.40	33.40
6	4924.00	46.5 AV	54.0	-7.5	1.74 V	206	13.10	33.40
7	7386.00	53.3 PK	74.0	-20.7	1.55 V	209	14.03	39.27
8	7386.00	40.6 AV	54.0	-13.4	1.55 V	209	1.33	39.27

**REMARKS:**

1. Emission Level(dBuV/m) = Raw Value(dBuV) + Correction Factor(dB/m)
2. Correction Factor(dB/m) = Antenna Factor(dB/m) + Cable Factor(dB) – Pre-Amplifier Factor(dB)
3. The other emission levels were very low against the limit.
4. Margin value = Emission Level – Limit value
5. " \* ": Fundamental frequency.

802.11n (HT20)

<b>CHANNEL</b>	TX Channel 1	<b>DETECTOR FUNCTION</b>	Peak (PK)
<b>FREQUENCY RANGE</b>	1GHz ~ 25GHz		Average (AV)

**ANTENNA POLARITY & TEST DISTANCE: HORIZONTAL AT 3 M**

NO.	FREQ. (MHz)	EMISSION LEVEL (dBuV/m)	LIMIT (dBuV/m)	MARGIN (dB)	ANTENNA HEIGHT (m)	TABLE ANGLE (Degree)	RAW VALUE (dBuV)	CORRECTION FACTOR (dB/m)
1	2390.00	65.5 PK	74.0	-8.5	1.62 H	69	37.81	27.69
2	2390.00	42.6 AV	54.0	-11.4	1.62 H	69	14.91	27.69
3	*2412.00	96.1 PK			1.62 H	69	68.35	27.75
4	*2412.00	86.8 AV			1.62 H	69	59.05	27.75
5	4824.00	53.2 PK	74.0	-20.8	1.52 H	191	20.06	33.14
6	4824.00	50.5 AV	54.0	-3.5	1.52 H	191	17.36	33.14

**ANTENNA POLARITY & TEST DISTANCE: VERTICAL AT 3 M**

NO.	FREQ. (MHz)	EMISSION LEVEL (dBuV/m)	LIMIT (dBuV/m)	MARGIN (dB)	ANTENNA HEIGHT (m)	TABLE ANGLE (Degree)	RAW VALUE (dBuV)	CORRECTION FACTOR (dB/m)
1	2390.00	73.5 PK	74.0	-0.5	1.86 V	356	45.81	27.69
2	2390.00	50.6 AV	54.0	-3.4	1.86 V	356	22.91	27.69
3	*2412.00	106.1 PK			1.86 V	356	78.35	27.75
4	*2412.00	95.5 AV			1.86 V	356	67.75	27.75
5	4824.00	56.2 PK	74.0	-17.8	1.84 V	105	23.06	33.14
6	4824.00	53.5 AV	54.0	-0.5	1.84 V	105	20.36	33.14

**REMARKS:**

1. Emission Level(dBuV/m) = Raw Value(dBuV) + Correction Factor(dB/m)
2. Correction Factor(dB/m) = Antenna Factor(dB/m) + Cable Factor(dB) – Pre-Amplifier Factor(dB)
3. The other emission levels were very low against the limit.
4. Margin value = Emission Level – Limit value
5. " \* ": Fundamental frequency.

<b>CHANNEL</b>	TX Channel 6	<b>DETECTOR FUNCTION</b>	Peak (PK)
<b>FREQUENCY RANGE</b>	1GHz ~ 25GHz		Average (AV)

**ANTENNA POLARITY & TEST DISTANCE: HORIZONTAL AT 3 M**

NO.	FREQ. (MHz)	EMISSION LEVEL (dBuV/m)	LIMIT (dBuV/m)	MARGIN (dB)	ANTENNA HEIGHT (m)	TABLE ANGLE (Degree)	RAW VALUE (dBuV)	CORRECTION FACTOR (dB/m)
1	2390.00	51.3 PK	74.0	-22.7	1.53 H	342	23.61	27.69
2	2390.00	38.9 AV	54.0	-15.1	1.53 H	342	11.21	27.69
3	*2437.00	101.5 PK			1.53 H	342	73.68	27.82
4	*2437.00	90.9 AV			1.53 H	342	63.08	27.82
5	2483.50	47.6 PK	74.0	-26.4	1.53 H	342	19.65	27.95
6	2483.50	34.9 AV	54.0	-19.1	1.53 H	342	6.95	27.95
7	4874.00	47.5 PK	74.0	-26.5	1.50 H	118	14.23	33.27
8	4874.00	43.3 AV	54.0	-10.7	1.50 H	118	10.03	33.27
9	7311.00	50.3 PK	74.0	-23.7	1.52 H	147	10.99	39.31
10	7311.00	37.4 AV	54.0	-16.6	1.52 H	147	-1.91	39.31

**ANTENNA POLARITY & TEST DISTANCE: VERTICAL AT 3 M**

NO.	FREQ. (MHz)	EMISSION LEVEL (dBuV/m)	LIMIT (dBuV/m)	MARGIN (dB)	ANTENNA HEIGHT (m)	TABLE ANGLE (Degree)	RAW VALUE (dBuV)	CORRECTION FACTOR (dB/m)
1	2390.00	59.3 PK	74.0	-14.7	2.05 V	360	31.61	27.69
2	2390.00	46.0 AV	54.0	-8.0	2.05 V	360	18.31	27.69
3	*2437.00	111.5 PK			2.05 V	360	83.68	27.82
4	*2437.00	100.9 AV			2.05 V	360	73.08	27.82
5	2483.50	55.0 PK	74.0	-19.0	2.05 V	360	27.05	27.95
6	2483.50	42.0 AV	54.0	-12.0	2.05 V	360	14.05	27.95
7	4874.00	50.5 PK	74.0	-23.5	1.76 V	210	17.23	33.27
8	4874.00	46.3 AV	54.0	-7.7	1.76 V	210	13.03	33.27
9	7311.00	53.3 PK	74.0	-20.7	1.52 V	198	13.99	39.31
10	7311.00	40.4 AV	54.0	-13.6	1.52 V	198	1.09	39.31

**REMARKS:**

1. Emission Level(dBuV/m) = Raw Value(dBuV) + Correction Factor(dB/m)
2. Correction Factor(dB/m) = Antenna Factor(dB/m) + Cable Factor(dB) – Pre-Amplifier Factor(dB)
3. The other emission levels were very low against the limit.
4. Margin value = Emission Level – Limit value
5. " \* ": Fundamental frequency.

<b>CHANNEL</b>	TX Channel 11	<b>DETECTOR FUNCTION</b>	Peak (PK)
<b>FREQUENCY RANGE</b>	1GHz ~ 25GHz		Average (AV)

**ANTENNA POLARITY & TEST DISTANCE: HORIZONTAL AT 3 M**

NO.	FREQ. (MHz)	EMISSION LEVEL (dBuV/m)	LIMIT (dBuV/m)	MARGIN (dB)	ANTENNA HEIGHT (m)	TABLE ANGLE (Degree)	RAW VALUE (dBuV)	CORRECTION FACTOR (dB/m)
1	*2462.00	100.2 PK			1.59 H	338	72.31	27.89
2	*2462.00	90.1 AV			1.59 H	338	62.21	27.89
3	2483.50	64.4 PK	74.0	-9.6	1.59 H	338	36.45	27.95
4	2483.50	45.8 AV	54.0	-8.2	1.59 H	338	17.85	27.95
5	4924.00	48.1 PK	74.0	-25.9	1.52 H	137	14.70	33.40
6	4924.00	43.9 AV	54.0	-10.1	1.52 H	137	10.50	33.40
7	7386.00	50.5 PK	74.0	-23.5	1.53 H	135	11.23	39.27
8	7386.00	37.6 AV	54.0	-16.4	1.53 H	135	-1.67	39.27

**ANTENNA POLARITY & TEST DISTANCE: VERTICAL AT 3 M**

NO.	FREQ. (MHz)	EMISSION LEVEL (dBuV/m)	LIMIT (dBuV/m)	MARGIN (dB)	ANTENNA HEIGHT (m)	TABLE ANGLE (Degree)	RAW VALUE (dBuV)	CORRECTION FACTOR (dB/m)
1	*2462.00	109.6 PK			1.65 V	356	81.71	27.89
2	*2462.00	99.0 AV			1.65 V	356	71.11	27.89
3	2483.50	72.4 PK	74.0	-1.6	1.65 V	356	44.45	27.95
4	<b>2483.50</b>	<b>53.8 AV</b>	<b>54.0</b>	<b>-0.2</b>	<b>1.65 V</b>	<b>356</b>	<b>25.85</b>	<b>27.95</b>
5	4924.00	51.1 PK	74.0	-22.9	1.74 V	194	17.70	33.40
6	4924.00	46.9 AV	54.0	-7.1	1.74 V	194	13.50	33.40
7	7386.00	53.5 PK	74.0	-20.5	1.58 V	215	14.23	39.27
8	7386.00	40.6 AV	54.0	-13.4	1.58 V	215	1.33	39.27

**REMARKS:**

1. Emission Level(dBuV/m) = Raw Value(dBuV) + Correction Factor(dB/m)
2. Correction Factor(dB/m) = Antenna Factor(dB/m) + Cable Factor(dB) – Pre-Amplifier Factor(dB)
3. The other emission levels were very low against the limit.
4. Margin value = Emission Level – Limit value
5. " \* ": Fundamental frequency.

## 4.2 Conducted Emission Measurement

### 4.2.1 Limits of Conducted Emission Measurement

Frequency (MHz)	Conducted Limit (dBuV)	
	Quasi-peak	Average
0.15 - 0.5	66 - 56	56 - 46
0.50 - 5.0	56	46
5.0 - 30.0	60	50

Note: 1. The lower limit shall apply at the transition frequencies.

2. The limit decreases in line with the logarithm of the frequency in the range of 0.15 to 0.50MHz.

### 4.2.2 Test Instruments

DESCRIPTION & MANUFACTURER	MODEL NO.	SERIAL NO.	CALIBRATED DATE	CALIBRATED UNTIL
Test Receiver ROHDE & SCHWARZ	ESCS 30	100375	Apr. 29, 2014	Apr. 28, 2015
Line-Impedance Stabilization Network (for EUT) SCHWARZBECK	NSLK-8127	8127-522	Sep. 15, 2014	Sep. 14, 2015
Line-Impedance Stabilization Network (for Peripheral) ROHDE & SCHWARZ	ENV216	100071	Nov. 10, 2014	Nov. 09, 2015
RF Cable (JYEBAO)	5DFB	COCCAB-001	Mar. 10, 2014	Mar. 09, 2015
50 ohms Terminator	N/A	EMC-03	Sep. 22, 2014	Sep. 21, 2015
50 ohms Terminator	N/A	EMC-02	Sep. 30, 2014	Sep. 29, 2015
Software ADT	BV ADT_Cond_V7.3.7. 3	NA	NA	NA

**Note:**

1. The calibration interval of the above test instruments is 12 months and the calibrations are traceable to NML/ROC and NIST/USA.
2. The test was performed in Shielded Room No. C.
3. The VCCI Con C Registration No. is C-3611.
4. Tested Date: Jan. 15, 2015

4.2.3 Test Procedures

- a. The EUT was placed 0.4 meters from the conducting wall of the shielded room with EUT being connected to the power mains through a line impedance stabilization network (LISN). Other support units were connected to the power mains through another LISN. The two LISNs provide 50 ohm/ 50uH of coupling impedance for the measuring instrument.
- b. Both lines of the power mains connected to the EUT were checked for maximum conducted interference.
- c. The frequency range from 150kHz to 30MHz was searched. Emission levels under (Limit - 20dB) was not recorded.

**NOTE:** The resolution bandwidth and video bandwidth of test receiver is 9kHz for quasi-peak detection (QP) and average detection (AV) at frequency 0.15MHz-30MHz.

4.2.4 Deviation from Test Standard

No deviation.

4.2.5 Test Setup

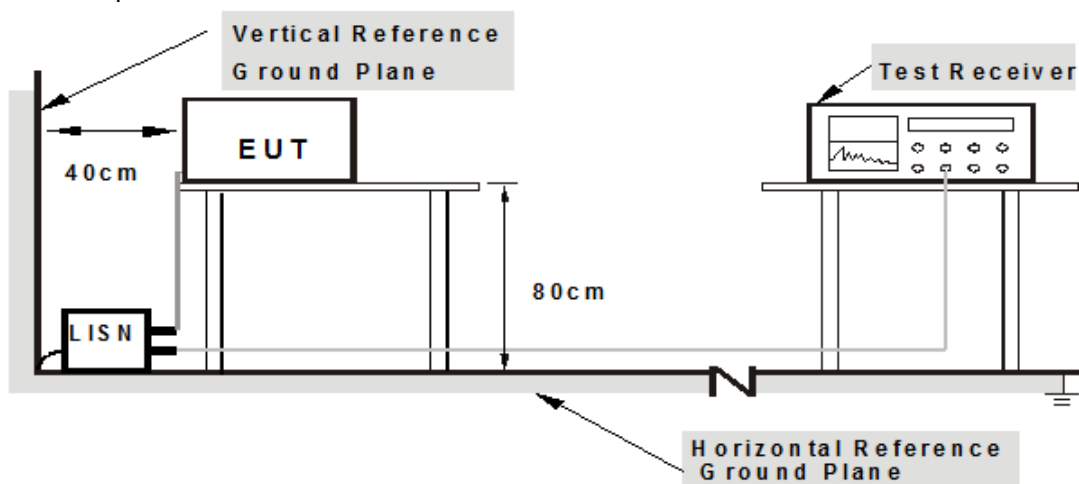

**Note: 1. Support units were connected to second LISN.**

For the actual test configuration, please refer to the attached file (Test Setup Photo).

4.2.6 EUT Operating Conditions

Same as 4.1.6.

#### 4.2.7 Test Results

Phase	Line (L)	Detector Function	Quasi-Peak (QP) / Average (AV)
-------	----------	-------------------	--------------------------------

No	Freq. [MHz]	Corr.	Reading Value		Emission Level		Limit		Margin	
		Factor	[dB (uV)]		[dB (uV)]		[dB (uV)]		(dB)	
	(dB)	Q.P.	AV.	Q.P.	AV.	Q.P.	AV.	Q.P.	AV.	
1	0.15391	0.07	49.97	35.15	50.04	35.22	65.79	55.79	-15.75	-20.57
<b>2</b>	<b>0.40391</b>	<b>0.09</b>	<b>51.09</b>	<b>44.13</b>	<b>51.18</b>	<b>44.22</b>	<b>57.77</b>	<b>47.77</b>	<b>-6.59</b>	<b>-3.55</b>
3	0.63047	0.11	37.94	22.86	38.05	22.97	56.00	46.00	-17.95	-23.03
4	0.79063	0.12	42.23	28.58	42.35	28.70	56.00	46.00	-13.65	-17.30
5	14.55469	0.57	35.57	30.70	36.14	31.27	60.00	50.00	-23.86	-18.73
6	18.92188	0.68	27.56	20.20	28.24	20.88	60.00	50.00	-31.76	-29.12

**Remarks:**

1. Q.P. and AV. are abbreviations of quasi-peak and average individually.
2. The emission levels of other frequencies were very low against the limit.
3. Margin value = Emission level – Limit value
4. Correction factor = Insertion loss + Cable loss
5. Emission Level = Correction Factor + Reading Value

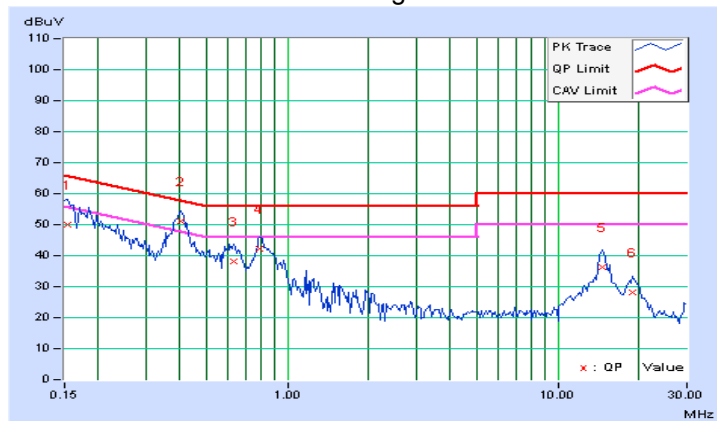



Phase	Neutral (N)	Detector Function	Quasi-Peak (QP) / Average (AV)
-------	-------------	-------------------	--------------------------------

No	Freq. [MHz]	Corr.	Reading Value		Emission Level		Limit		Margin	
		Factor	[dB (uV)]		[dB (uV)]		[dB (uV)]		(dB)	
		(dB)	Q.P.	AV.	Q.P.	AV.	Q.P.	AV.	Q.P.	AV.
1	0.16172	0.06	53.14	41.09	53.20	41.15	65.38	55.38	-12.17	-14.22
2	0.39219	0.09	47.00	34.32	47.09	34.41	58.02	48.02	-10.93	-13.61
3	0.63828	0.11	34.71	27.39	34.82	27.50	56.00	46.00	-21.18	-18.50
4	0.80234	0.12	36.00	24.33	36.12	24.45	56.00	46.00	-19.88	-21.55
5	14.54297	0.60	35.85	31.06	36.45	31.66	60.00	50.00	-23.55	-18.34
6	19.01953	0.71	28.47	20.85	29.18	21.56	60.00	50.00	-30.82	-28.44

**Remarks:**

1. Q.P. and AV. are abbreviations of quasi-peak and average individually.
2. The emission levels of other frequencies were very low against the limit.
3. Margin value = Emission level – Limit value
4. Correction factor = Insertion loss + Cable loss
5. Emission Level = Correction Factor + Reading Value

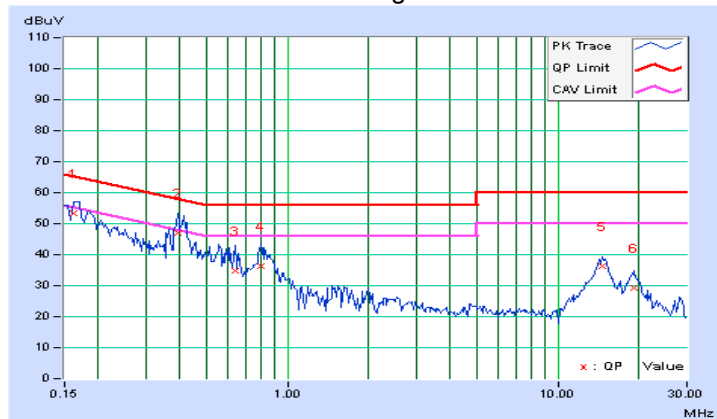

**4.3 6dB Bandwidth Measurement**

4.3.1 Limits of 6dB Bandwidth Measurement

The minimum of 6dB Bandwidth Measurement is 0.5 MHz.

4.3.2 Test Setup

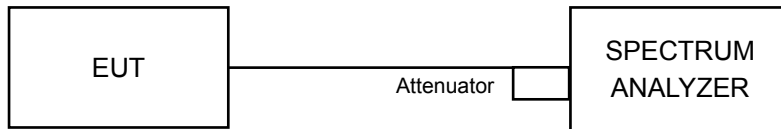

4.3.3 Test Instruments

DESCRIPTION & MANUFACTURER	MODEL NO.	SERIAL NO.	CALIBRATED DATE	CALIBRATED UNTIL
SPECTRUM ANALYZER R&S	FSP 40	100060	May 08, 2014	May 07, 2015

**Note:**

1. The calibration interval of the above test instruments is 12 months and the calibrations are traceable to NML/ROC and NIST/USA.
2. Tested date : Jan. 15, 2015

4.3.4 Test Procedure

- a. Set resolution bandwidth (RBW) = 100kHz
- b. Set the video bandwidth (VBW)  $\geq 3 \times$  RBW, Detector = Peak.
- c. Trace mode = max hold.
- d. Sweep = auto couple.
- e. Measure the maximum width of the emission that is constrained by the frequencies associated with the two amplitude points (upper and lower) that are attenuated by 6 dB relative to the maximum level measured in the fundamental emission

4.3.5 Deviation from Test Standard

No deviation.

4.3.6 EUT Operating Conditions

The software provided by client to enable the EUT under transmission condition continuously at lowest, middle and highest channel frequencies individually.

## 4.3.7 Test Result

## 802.11b

CHANNEL	FREQUENCY (MHz)	6dB BANDWIDTH (MHz)	MINIMUM LIMIT (MHz)	PASS / FAIL
1	2412	8.09	0.5	PASS
6	2437	8.08	0.5	PASS
11	2462	8.08	0.5	PASS

## 802.11g

CHANNEL	FREQUENCY (MHz)	6dB BANDWIDTH (MHz)	MINIMUM LIMIT (MHz)	PASS / FAIL
1	2412	15.39	0.5	PASS
6	2437	15.39	0.5	PASS
11	2462	15.50	0.5	PASS

## 802.11n (HT20)

CHANNEL	FREQUENCY (MHz)	6dB BANDWIDTH (MHz)	MINIMUM LIMIT (MHz)	PASS / FAIL
1	2412	15.17	0.5	PASS
6	2437	15.19	0.5	PASS
11	2462	16.03	0.5	PASS

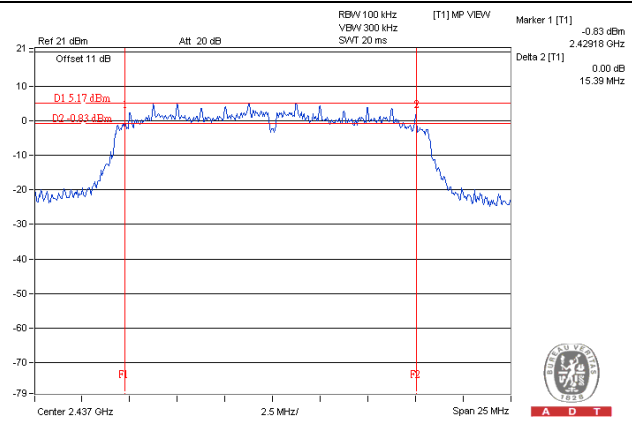
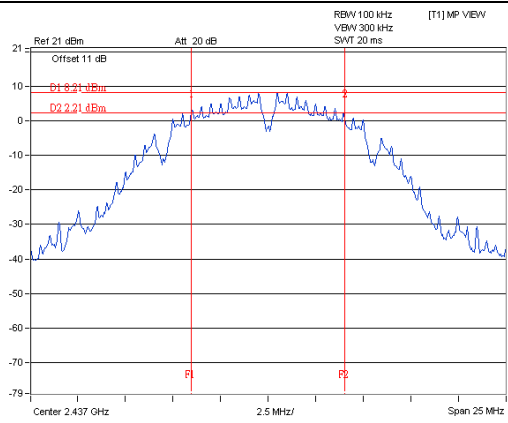
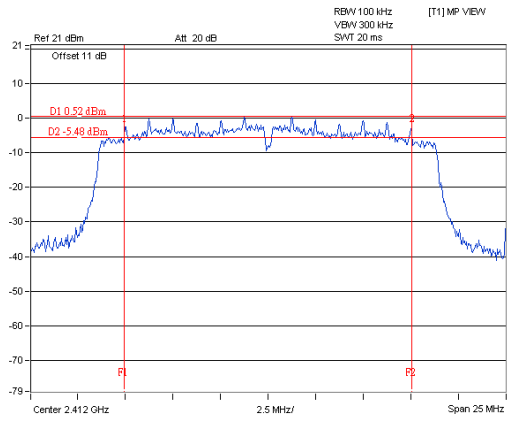
**SPECTRUM PLOT OF WORST VALUE****802.11b: CH6****802.11g: CH6****802.11n (HT20): CH1**

#### 4.4 Conducted Output Power Measurement

##### 4.4.1 Limits of Conducted Output Power Measurement

For systems using digital modulation in the 2400–2483.5 MHz bands: 1 Watt (30dBm)

##### 4.4.2 Test Setup

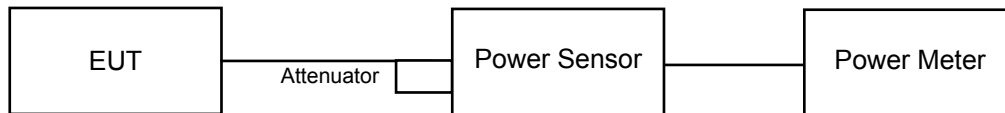

##### 4.4.3 Test Instruments

DESCRIPTION & MANUFACTURER	MODEL NO.	SERIAL NO.	CALIBRATED DATE	CALIBRATED UNTIL
Power meter Anritsu	ML2495A	1014008	Apr. 30, 2014	Apr. 29, 2015
Power sensor Anritsu	MA2411B	0917122	Apr. 30, 2014	Apr. 29, 2015

**Note:**

1. The calibration interval of the above test instruments is 12 months and the calibrations are traceable to NML/ROC and NIST/USA.
2. Tested date : Jan. 15, 2015

##### 4.4.4 Test Procedures

A peak / average power sensor was used on the output port of the EUT. A power meter was used to read the response of the peak / average power sensor. Record the power level.

##### 4.4.5 Deviation from Test Standard

No deviation.

##### 4.4.6 EUT Operating Conditions

Same as Item 4.3.6.

4.4.7 Test Results

**FOR PEAK POWER**

**802.11b**

CHANNEL	FREQUENCY (MHz)	PEAK POWER (mW)	PEAK POWER (dBm)	LIMIT (dBm)	PASS/FAIL
1	2412	59.02	17.71	30	PASS
6	2437	74.131	18.70	30	PASS
11	2462	77.625	18.90	30	PASS

**802.11g**

CHANNEL	FREQUENCY (MHz)	PEAK POWER (mW)	PEAK POWER (dBm)	LIMIT (dBm)	PASS/FAIL
1	2412	105.925	20.25	30	PASS
6	2437	136.144	21.34	30	PASS
11	2462	147.911	21.70	30	PASS

**802.11n (HT20)**

CHANNEL	FREQUENCY (MHz)	PEAK POWER (mW)	PEAK POWER (dBm)	LIMIT (dBm)	PASS/FAIL
1	2412	118.577	20.74	30	PASS
6	2437	147.231	21.68	30	PASS
11	2462	110.154	20.42	30	PASS

**FOR AVERAGE POWER****802.11b**

CHANNEL	FREQUENCY (MHz)	AVERAGE POWER (mW)	AVERAGE POWER (dBm)
1	2412	30.200	14.80
6	2437	47.863	16.80
11	2462	45.082	16.54

**802.11g**

CHANNEL	FREQUENCY (MHz)	AVERAGE POWER (mW)	AVERAGE POWER (dBm)
1	2412	12.735	11.05
6	2437	36.392	15.61
11	2462	37.154	15.70

**802.11n (HT20)**

CHANNEL	FREQUENCY (MHz)	AVERAGE POWER (mW)	AVERAGE POWER (dBm)
1	2412	12.794	11.07
6	2437	38.107	15.81
11	2462	23.714	13.75

## 4.5 Power Spectral Density Measurement

### 4.5.1 Limits of Power Spectral Density Measurement

The Maximum of Power Spectral Density Measurement is 8dBm.

### 4.5.2 Test Setup

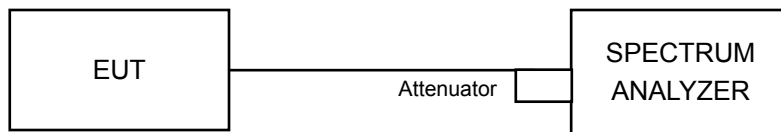

### 4.5.3 Test Instruments

Refer to section 4.3.3 to get information of above instrument.

### 4.5.4 Test Procedure

- a. Set analyzer center frequency to DTS channel center frequency.
- b. Set the span to 1.5 times the DTS bandwidth.
- c. Set the RBW to:  $3 \text{ kHz} \leq \text{RBW} \leq 100 \text{ kHz}$ .
- d. Set the VBW  $\geq 3 \times \text{RBW}$ .
- e. Detector = peak.
- f. Sweep time = auto couple.
- g. Trace mode = max hold.
- h. Allow trace to fully stabilize.
- i. Use the peak marker function to determine the maximum amplitude level within the RBW.

### 4.5.5 Deviation from Test Standard

No deviation.

### 4.5.6 EUT Operating Condition

Same as Item 4.3.6



#### 4.5.7 Test Results

##### 802.11b

Channel	Freq. (MHz)	PSD (dBm/3kHz)	Limit (dBm/3kHz)	PASS /FAIL
1	2412	-7.10	8	PASS
6	2437	-5.53	8	PASS
11	2462	-6.03	8	PASS

##### 802.11g

Channel	Freq. (MHz)	PSD (dBm/3kHz)	Limit (dBm/3kHz)	PASS /FAIL
1	2412	-14.35	8	PASS
6	2437	-8.75	8	PASS
11	2462	-9.31	8	PASS

##### 802.11n (HT20)

Channel	Freq. (MHz)	PSD (dBm/3kHz)	Limit (dBm/3kHz)	PASS /FAIL
1	2412	-13.78	8	PASS
6	2437	-9.00	8	PASS
11	2462	-11.40	8	PASS

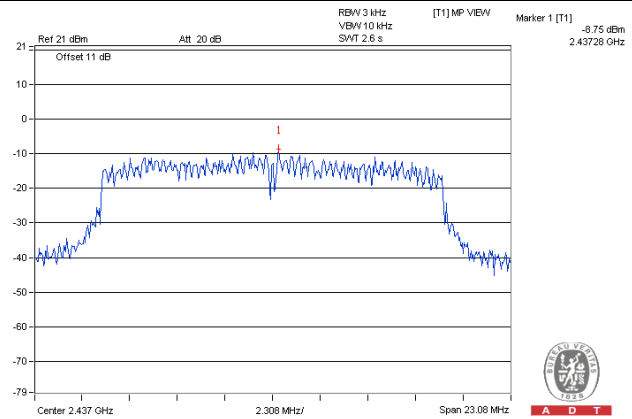
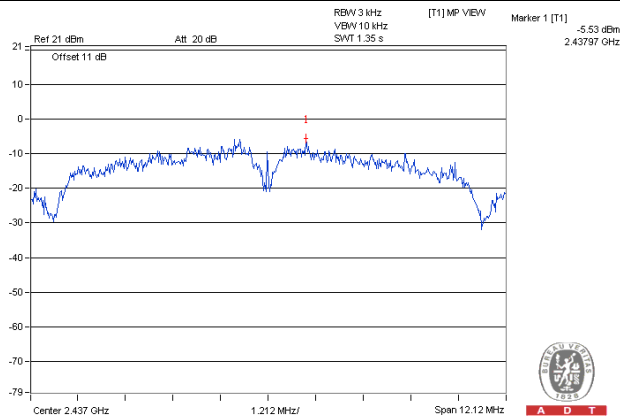
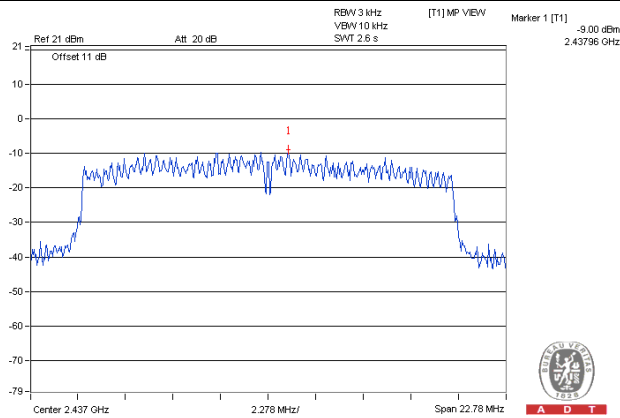
**SPECTRUM PLOT OF WORST VALUE****802.11b: CH6****802.11g: CH6****802.11n (HT20): CH6**

## 4.6 Conducted Out of Band Emission Measurement

### 4.6.1 Limits of Conducted Out of Band Emission Measurement

Below 20dB of the highest emission level of operating band (in 100kHz Resolution Bandwidth).

### 4.6.2 Test Setup

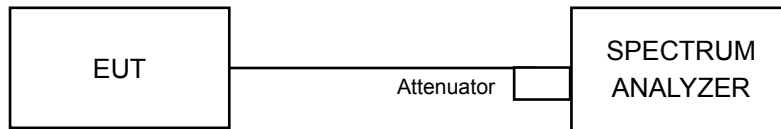

### 4.6.3 Test Instruments

Refer to section 4.3.3 to get information of above instrument.

### 4.6.4 Test Procedure

#### MEASUREMENT PROCEDURE REF

1. Set the RBW = 100 kHz.
2. Set the VBW  $\geq$  300 kHz.
3. Detector = peak.
4. Sweep time = auto couple.
5. Trace mode = max hold.
6. Allow trace to fully stabilize.
7. Use the peak marker function to determine the maximum power level in any 100 kHz band segment within the fundamental EBW.

#### MEASUREMENT PROCEDURE OOBE

1. Set RBW = 100 kHz.
2. Set VBW  $\geq$  300 kHz.
3. Detector = peak.
4. Sweep = auto couple.
5. Trace Mode = max hold.
6. Allow trace to fully stabilize.
7. Use the peak marker function to determine the maximum amplitude level.

### 4.6.5 Deviation from Test Standard

No deviation.

### 4.6.6 EUT Operating Condition

Same as Item 4.3.6

4.6.7 Test Results  
802.11b

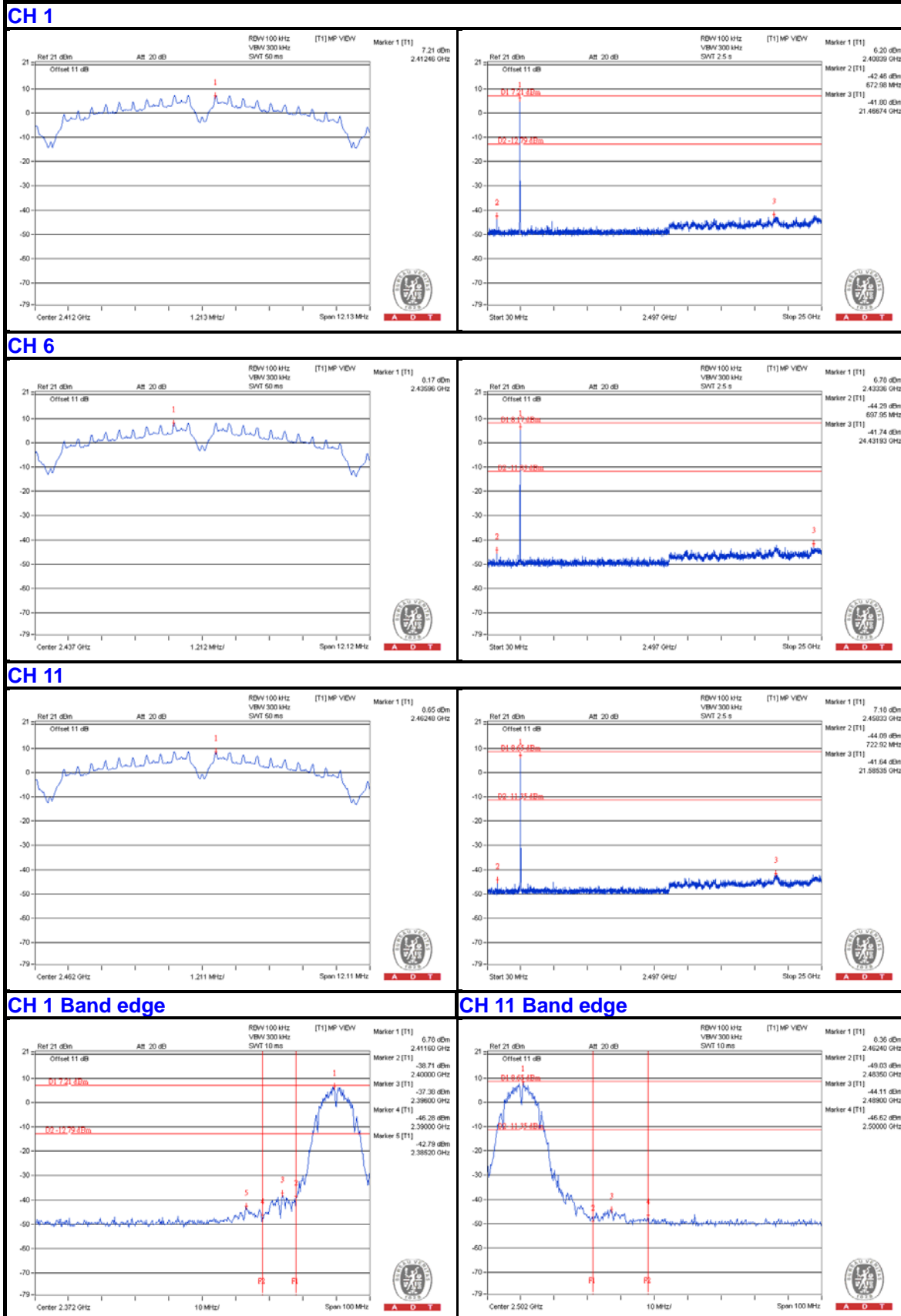

802.11g

CH 1

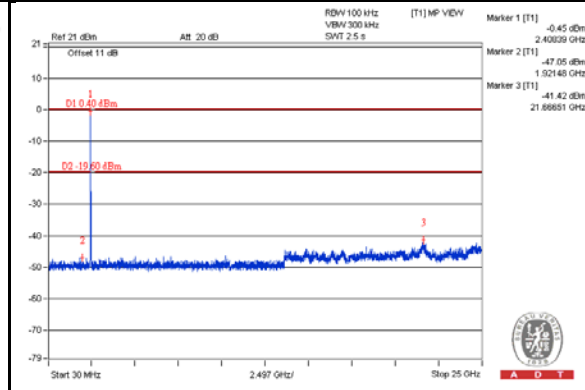
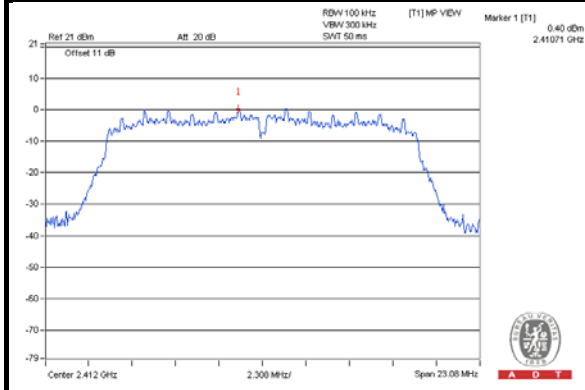

CH 6

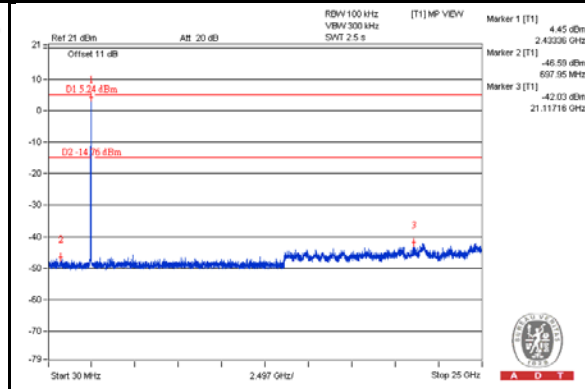
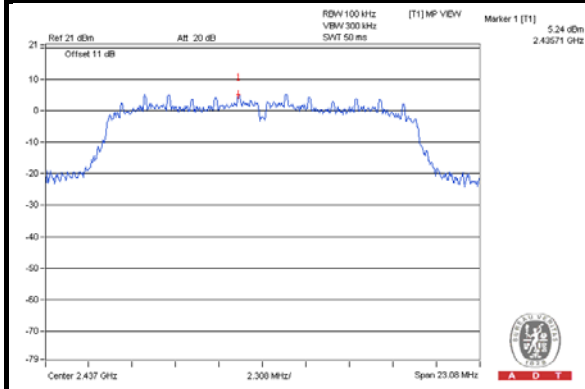

CH 11

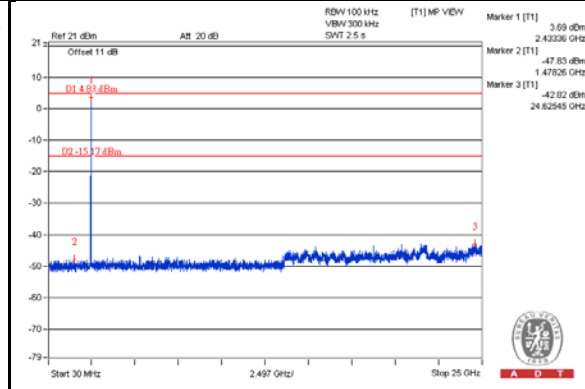
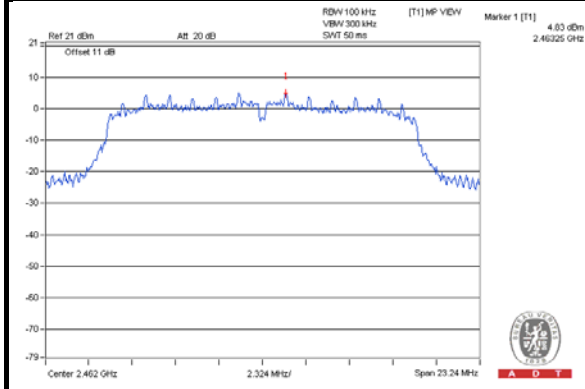

CH 1 Band edge

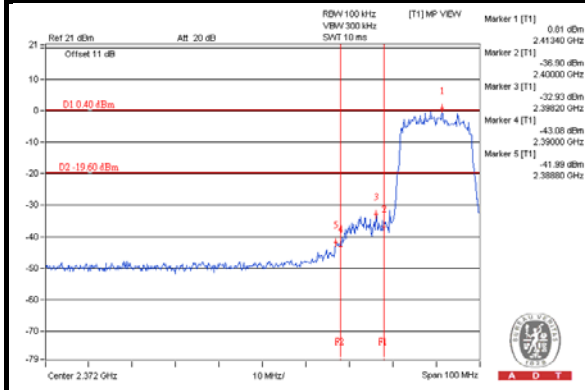

CH 11 Band edge

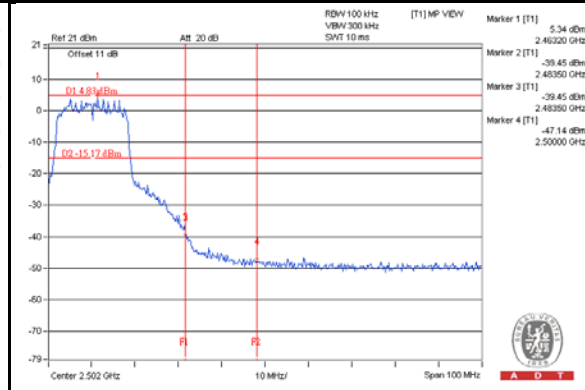

802.11n (HT20)

CH 1

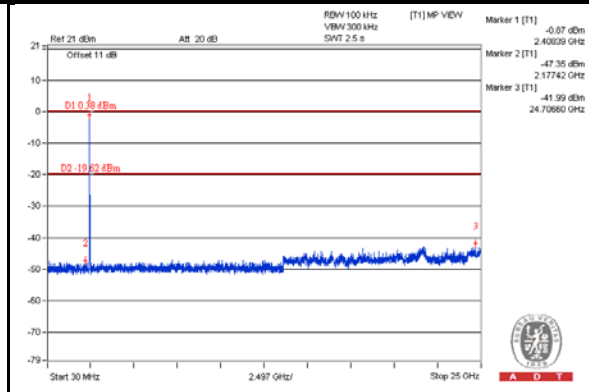
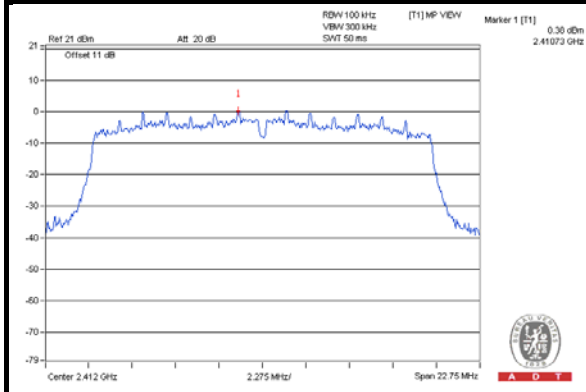

CH 6

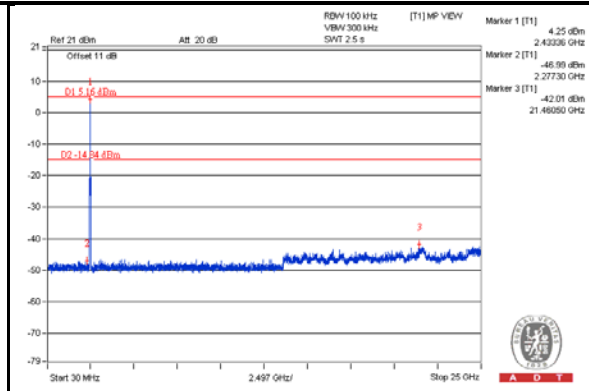
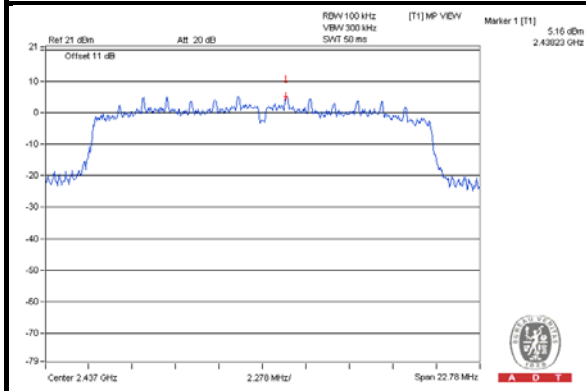

CH 11

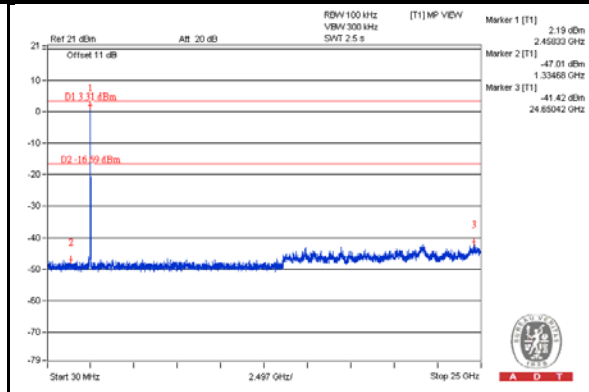
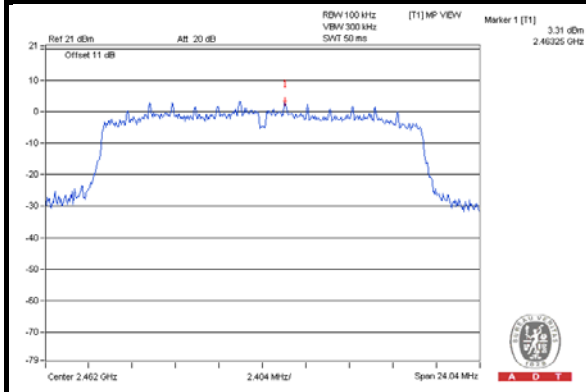

CH 1 Band edge

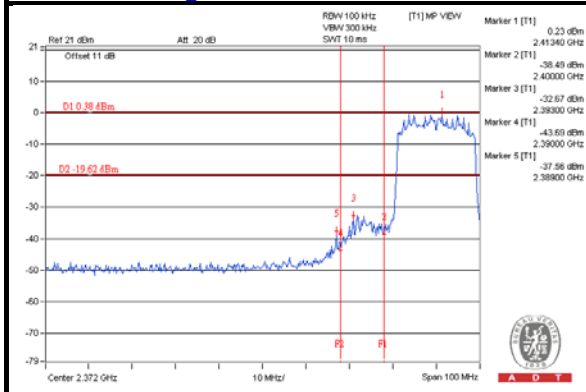

CH 11 Band edge

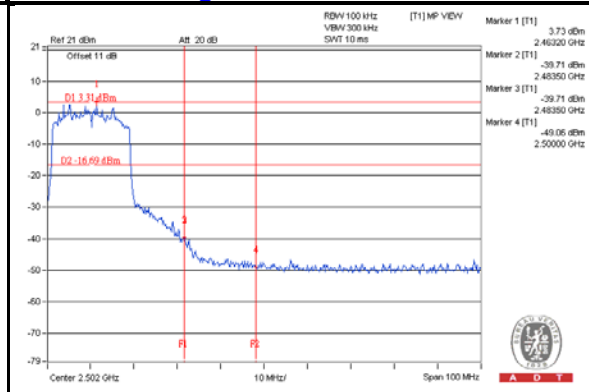

## 5 Pictures of Test Arrangements

Please refer to the attached file (Test Setup Photo).



## Appendix – Information on the Testing Laboratories

We, Bureau Veritas Consumer Products Services (H.K.) Ltd., Taoyuan Branch, were founded in 1988 to provide our best service in EMC, Radio, Telecom and Safety consultation. Our laboratories are accredited and approved according to ISO/IEC 17025.

If you have any comments, please feel free to contact us at the following:

**Linko EMC/RF Lab**

Tel: 886-2-26052180

Fax: 886-2-26051924

**Hsin Chu EMC/RF/Telecom Lab**

Tel: 886-3-5935343

Fax: 886-3-5935342

**Hwa Ya EMC/RF/Safety Lab**

Tel: 886-3-3183232

Fax: 886-3-3270892

**Email:** [service.adt@tw.bureauveritas.com](mailto:service.adt@tw.bureauveritas.com)

**Web Site:** [www.bureauveritas-adt.com](http://www.bureauveritas-adt.com)

The address and road map of all our labs can be found in our web site also.

--- END ---