

6dB Band Width Data CH-High

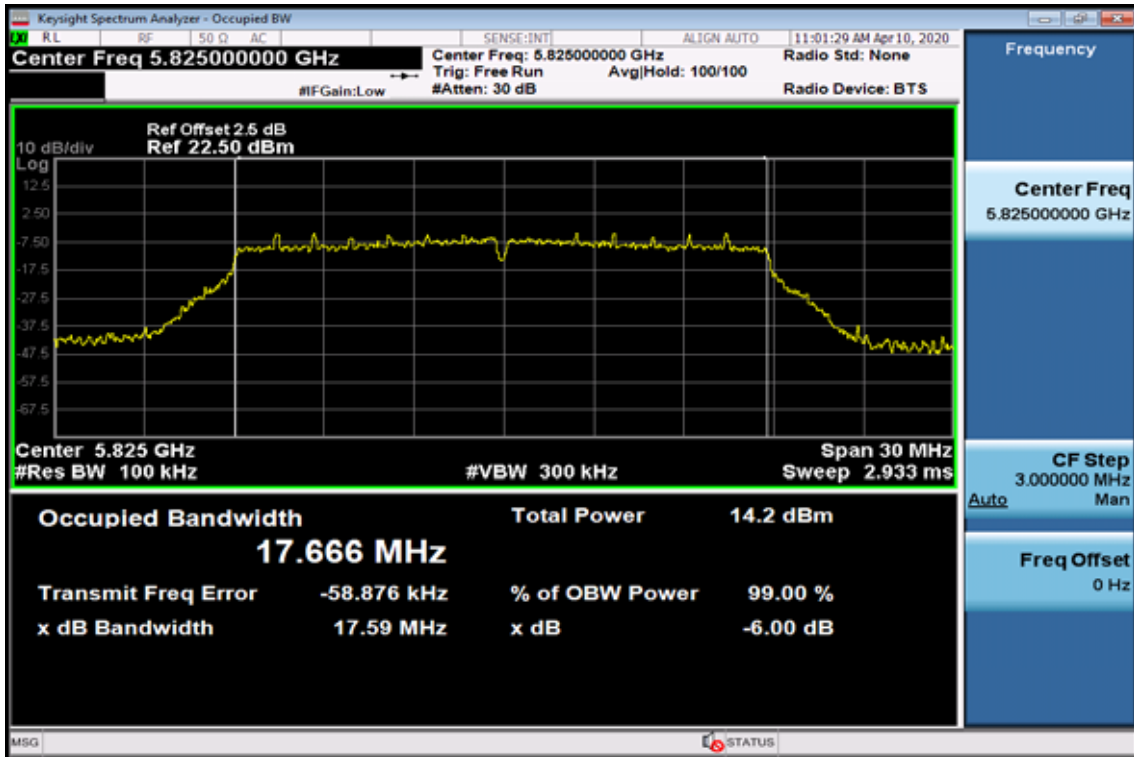

802.11n HT40

6dB Band Width Data CH-Low

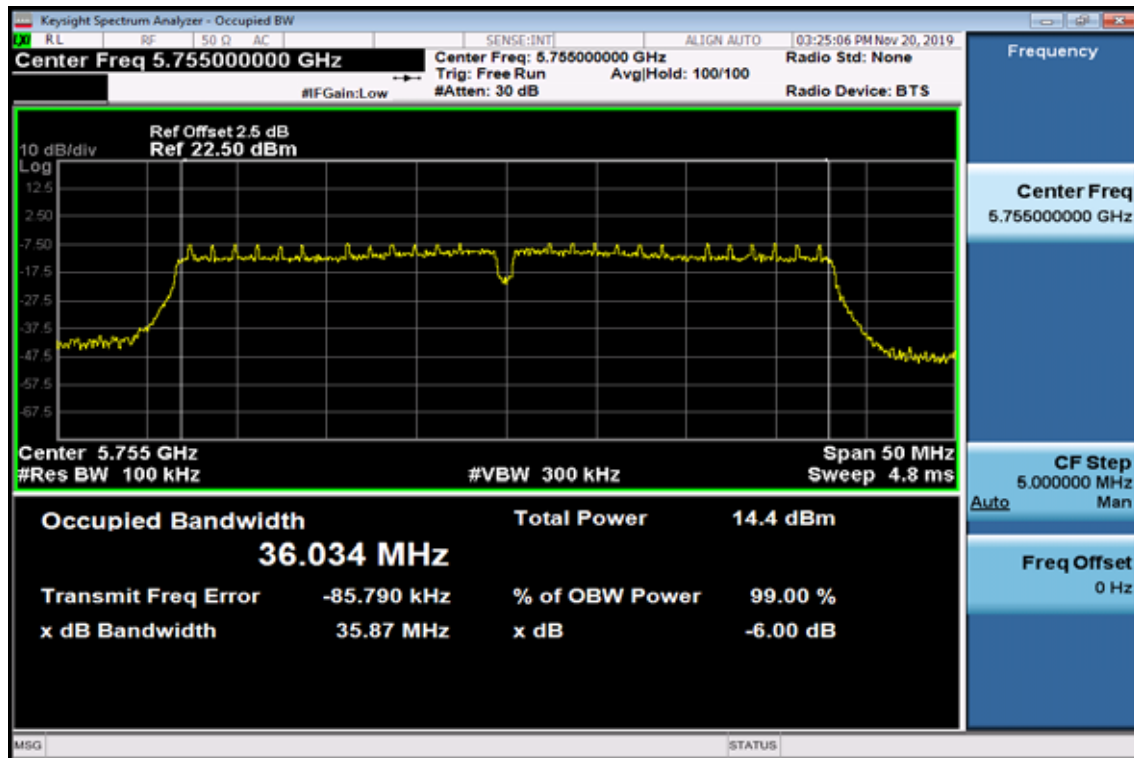

6dB Band Width Data CH-High

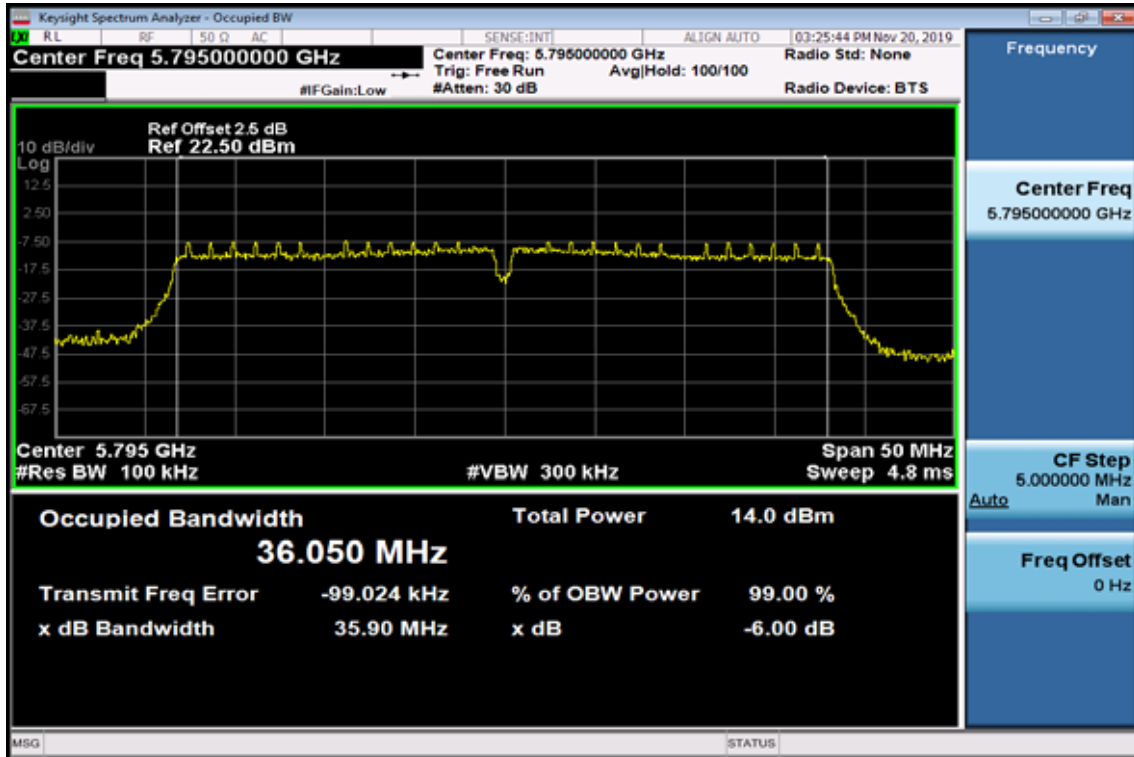

802.11ac VHT40

6dB Band Width Data CH-Low

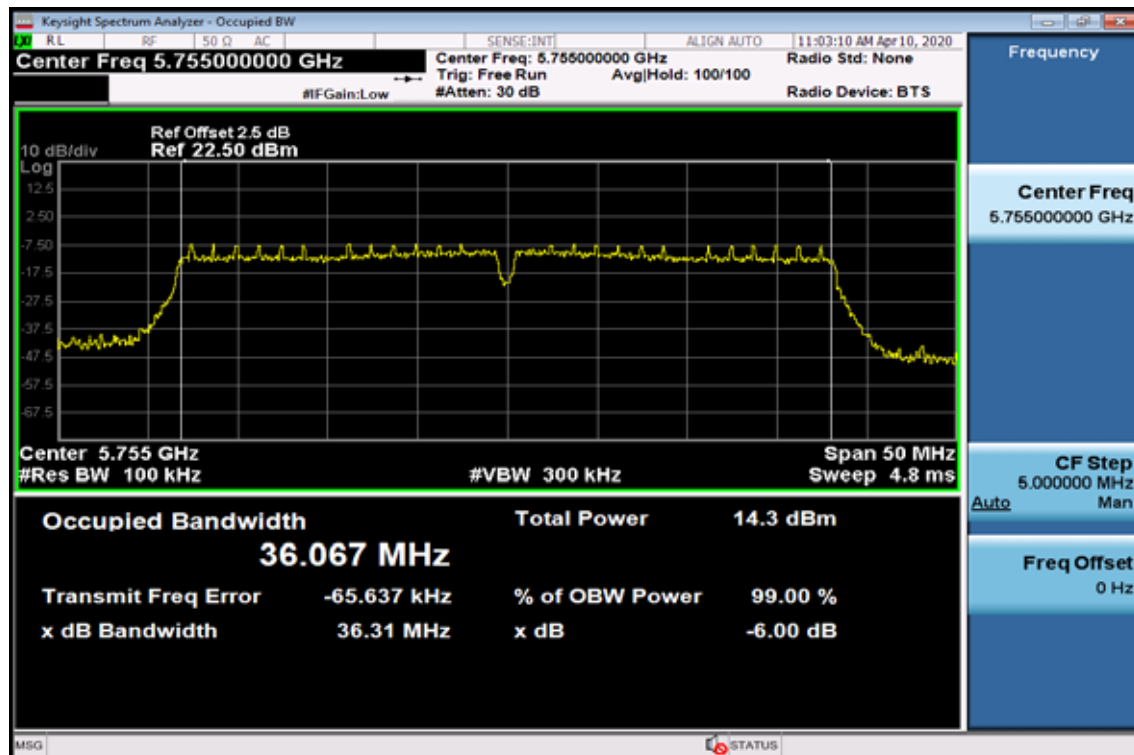

6dB Band Width Data CH-High

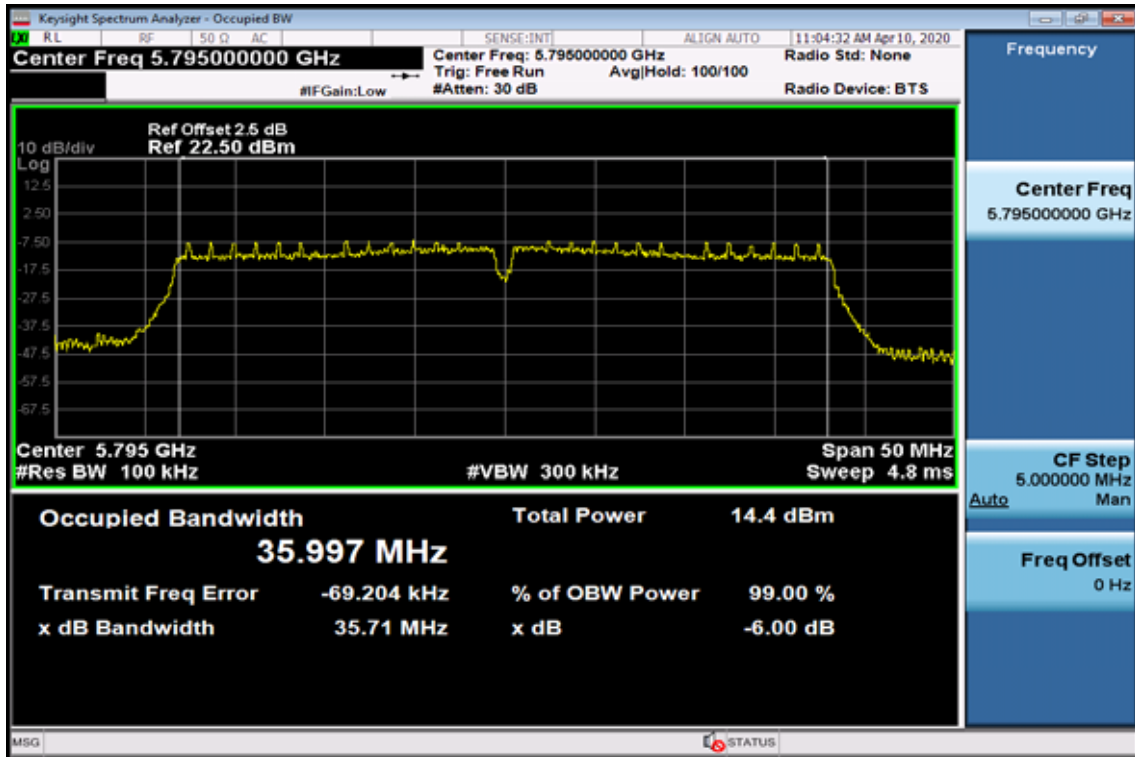

802.11 ac VHT80

6dB Band Width Data CH-Low

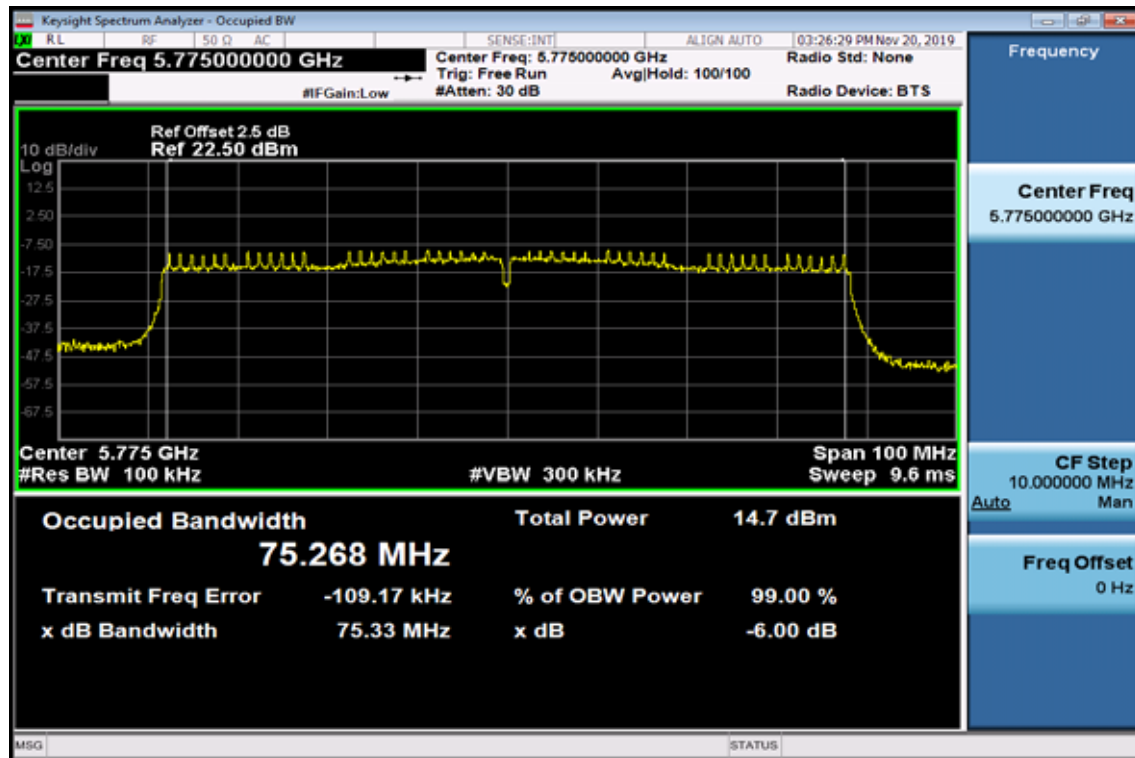

9. Undesirable emission – Radiated Measurement

9.1. Standard Applicable

According to §15.407(b), Undesirable Emission Limits: Except as shown in Paragraph (b)(7) of this section, the peak emissions outside of the frequency bands of operation shall be attenuated in accordance with the following limits:

- (1) For transmitters operating in the 5.15-5.25 GHz band: all emissions outside of the 5.15-5.35 GHz band shall not exceed an e.i.r.p. of -27 dBm/MHz.
- (2) For transmitters operating in the 5.25-5.35 GHz band: all emissions outside of the 5.15-5.35 GHz band shall not exceed an e.i.r.p. of -27 dBm/MHz.
- (3) For transmitters operating in the 5.47-5.725 GHz band: all emissions outside of the 5.47-5.725 GHz band shall not exceed an e.i.r.p. of -27 dBm/MHz.
- (4) For transmitters operating in the 5.725-5.85 GHz band: all emissions within the frequency range from the band edge to 10 MHz above or below the band edge shall not exceed an e.i.r.p. of -17dBm/MHz; for frequencies 10 MHz or greater above or below the band edge, emissions shall not exceed an e.i.r.p. of -27 dBm/MHz.
- (5) The above emission measurements shall be performed using a minimum resolution bandwidth of 1 MHz. A lower resolution bandwidth may be employed near the band edge, when necessary, provided the measured energy is integrated to show the total power over 1 MHz.
- (6) Unwanted emissions below 1 GHz must comply with the general field strength limits set forth in Section 15.209. Further, any U-NII devices using an AC power line are required to comply also with the conducted limits set forth in Section 15.207.
- (7) The provisions of Section 15.205 of this part apply to intentional radiators operating under this section.
- (8) When measuring the emission limits, the nominal carrier frequency shall be adjusted as close to the upper and lower frequency band edges as the design of the equipment permits.

§15.205- RESTRICTED BANDS OF OPERATIONS

(a) Except as shown in paragraph (d) of this section, only spurious emissions are permitted in any of the frequency bands listed below:

MHz	MHz	MHz	GHz
0.090 - 0.110	16.42 - 16.423	399.9 - 410	4.5 - 5.15
¹ 0.495 - 0.505	16.69475 - 16.69525	608 - 614	5.35 - 5.46
2.1735 - 2.1905	16.80425 - 16.80475	960 - 1240	7.25 - 7.75
4.125 - 4.128	25.5 - 25.67	1300 - 1427	8.025 - 8.5
4.17725 - 4.17775	37.5 - 38.25	1435 - 1626.5	9.0 - 9.2
4.20725 - 4.20775	73 - 74.6	1645.5 - 1646.5	9.3 - 9.5
6.215 - 6.218	74.8 - 75.2	1660 - 1710	10.6 - 12.7
6.26775 - 6.26825	108 - 121.94	1718.8 - 1722.2	13.25 - 13.4
6.31175 - 6.31225	123 - 138	2200 - 2300	14.47 - 14.5
8.291 - 8.294	149.9 - 150.05	2310 - 2390	15.35 - 16.2
8.362 - 8.366	156.52475 -	2483.5 - 2500	17.7 - 21.4
8.37625 - 8.38675	156.52525	2655 - 2900	22.01 - 23.12
8.41425 - 8.41475	156.7 - 156.9	3260 - 3267	23.6 - 24.0
12.29 - 12.293	162.0125 - 167.17	3332 - 3339	31.2 - 31.8
12.51975 - 12.52025	167.72 - 173.2	3345.8 - 3358	36.43 - 36.5
12.57675 - 12.57725	240 - 285	3600 - 4400	(²)
13.36 - 13.41	322 - 335.4		

¹ Until February 1, 1999, this restricted band shall be 0.490-0.510 MHz.

² Above 38.6

(b) Except as provided in paragraphs (d) and (e), the field strength of emissions appearing within these frequency bands shall not exceed the limits shown in Section 15.209. At frequencies equal to or less than 1000 MHz, compliance with the limits in Section 15.209 shall be demonstrated using measurement instrumentation employing a CISPR quasi-peak detector. Above 1000 MHz, compliance with the emission limits in Section 15.209 shall be demonstrated based on the average value of the measured emissions. The provisions in Section 15.35 apply to these measurements.

§15.209- RADIATED EMISSION LIMITS: GENERAL REQUIREMENTS

FCC PART 15.209

MEASURING DISTANCE OF 3 METER		
FREQUENCY RANGE (MHz)	FIELD STRENGTH (Microvolts/m)	FIELD STRENGTH (dBuV/m)
30-88	100	40
88-216	150	43.5
216-960	200	46
Above 960	500	54

9.2. EUT Setup

1. The radiated emission tests were performed in the 3 meter open-test site, using the setup in accordance with the ANSI C63.10: 2013
2. The EUT was put in the front of the test table. The host PC system was placed on the center of the back edge on the test table. The peripherals like modem, monitor printer, K/B, and mouse were placed on the side of the host PC system. The rear of the EUT and peripherals were placed flushed with the rear of the tabletop.
3. The keyboard was placed directly in the front of the monitor, flushed with the front tabletop. The mouse was placed next to the Keyboard, flushed with the back of keyboard.
4. The spacing between the peripherals was 10 centimeters.
5. External I/O cables were draped along the edge of the test table and bundle when necessary.
6. The host PC system was connected with 120Vac/60Hz power source.

9.3. Measurement Procedure

1. The EUT was placed on a turn table which is 0.8m above ground plane.
2. The turn table shall rotate 360 degrees to determine the position of maximum emission level.
3. EUT is set 3m away from the receiving antenna which varied from 1m to 4m to find out the highest emissions.
4. Maximum procedure was performed on the six highest emissions to ensure EUT compliance.
5. And also, each emission was to be maximized by changing the polarization of receiving antenna both horizontal and vertical.
6. Repeat above procedures until all frequency measured were complete.

Refer to section F of KDB Document: KDB 789033 D02 General U-NII Test Procedures New Rules v02r01

9.4. Test SET-UP (Block Diagram of Configuration)

(A) Radiated Emission Test Set-Up, Frequency Below 1000MHz

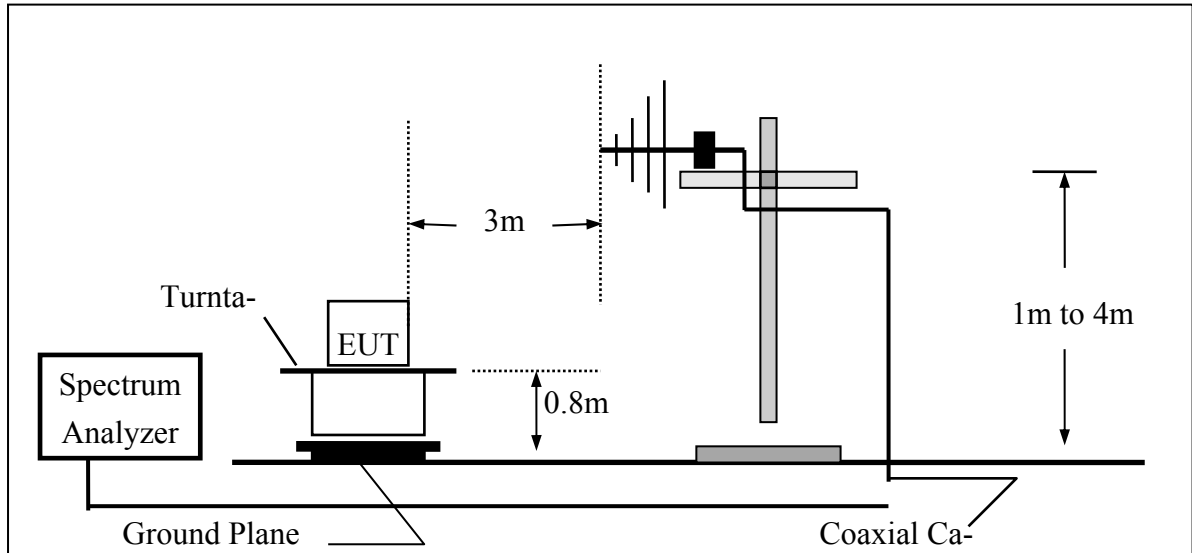

(B) Radiated Emission Test Set-UP Frequency Over 1 GHz

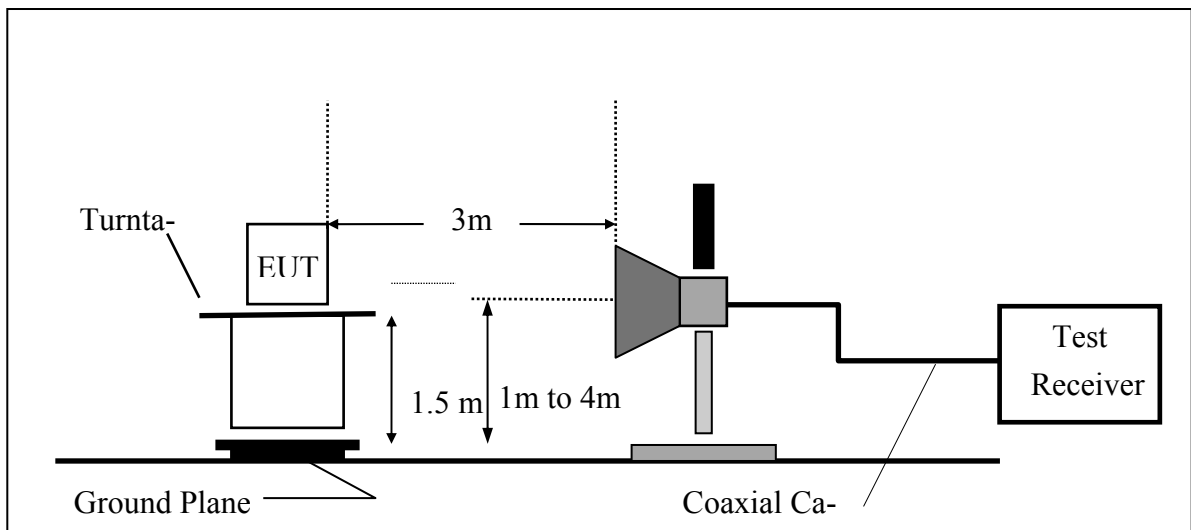

9.5. Measurement Equipment Used:

Chamber 19(966)					
Equipment Type	MFR	Model Number	Serial Number	Last Cal.	Cal Due.
Spectrum analyzer	R&S	FSP40	100116	01/10/2020	01/10/2021
EMI Receiver	R&S	ESR3	102461	08/08/2018	08/08/2020
Loop Antenna	EM	EM-6879	271	05/31/2019	05/31/2020
Bilog Antenna (30MHz-1GHz)	Schwarzbeck	VULB9168 w 5dB Att.	736	01/29/2019	01/29/2020
Bilog Antenna (30MHz-1GHz)	Schwarzbeck	VULB9168 w 5dB Att.	736	01/29/2020	01/29/2021
Horn antenna (1GHz-18GHz)	Schwarzbeck	9120D	9120D-1627	06/17/2019	06/17/2020
Horn antenna (18GHz-26GHz)	Com-power	AH-826	081001	11/21/2019	11/21/2020
Horn antenna (26GHz-40GHz)	Com-power	AH-640	100A	03/29/2019	03/29/2021
Preamplifier (9kHz-1GHz)	HP	8447F	3113A06362	01/14/2020	01/14/2021
Preamplifier (1GHz-26GHz)	Agilent	8449B	3008A02471	10/05/2019	10/05/2020
Preamplifier (26GHz-40GHz)	MITEQ	JS4-26004000-2 7-5A	818471	05/06/2019	05/06/2020
RF Cable (9kHz-18GHz)	HUBER SUHNER	Sucoflex 104A	MY1397/4A	01/17/2020	01/17/2021
RF Cable (18GHz-40GHz)	HUBER SUHNER	Sucoflex 102	27963/2&37421 /2	11/27/2019	11/27/2021
Signal Generator	Anritsu	MG3692A	20311	01/09/2020	01/09/2021
Test Software	Audix	E3 Ver:6.12023	N/A	N/A	N/A
Magnetic Field Meter	Combinova	MFM-10	645	10/16/2019	10/16/2020
Magnetic Field Meter	Combinova	MFM-1000	619	12/06/2019	12/06/2020
Electric Field Meter	Combinova	EFM-200	402	10/16/2019	10/16/2020
E-field probe	Narda / Wandel & Goltermann	EF-0691 + NBM-520	D-0135 + D-0526	03/02/2019	03/02/2020

9.6. Field Strength Calculation

The field strength is calculated by adding the Antenna Factor and Cable Factor and subtracting the Amplifier Gain and Duty Cycle Correction Factor (if any) from the measured reading. The basic equation with a sample calculation is as follows:

$$FS = RA + AF + CL - AG$$

Where	FS = Field Strength	CL = Cable Attenuation Factor (Cable Loss)
	RA = Reading Amplitude	AG = Amplifier Gain
	AF = Antenna Factor	

9.7. Measurement Result

Refer to attach tabular data sheets.

NOTE:

The resolution bandwidth and video bandwidth of test receiver/spectrum analyzer is 100kHz for Peak detection (PK) and Quasi-peak detection (QP) at frequency below 1GHz. And RBW 1MHz for frequency above 1GHz.

Dipole Ant

Radiated Spurious Emission Measurement Result (below 1GHz)

(Band UNII-1 / Band UNII-2A, 802.11a mode)

Operation Mode	TX MODE	Test Date	2020/01/21
Channel Number	CH Low	Test By	Barry
Temperature	25	Pol	Ver./Hor
Humidity	65 %		

No	Freq MHz	Reading dBuV	Factor dB	Level dBuV/m	Limit dBuV/m	Margin dB	Remark	Pol V/H
1	173.56	34.79	-5.52	29.27	43.50	-14.23	Peak	VERTICAL
2	497.54	30.38	-0.67	29.71	46.00	-16.29	Peak	VERTICAL
3	516.94	34.70	-0.05	34.65	46.00	-11.35	Peak	VERTICAL
4	570.29	29.50	0.71	30.21	46.00	-15.79	Peak	VERTICAL
5	625.58	28.68	1.77	30.45	46.00	-15.55	Peak	VERTICAL
6	952.47	30.91	7.02	37.93	46.00	-8.07	Peak	VERTICAL
1	178.41	36.89	-5.97	30.92	43.50	-12.58	Peak	HORIZONTAL
2	427.70	33.13	-1.48	31.65	46.00	-14.35	Peak	HORIZONTAL
3	641.10	28.66	1.96	30.62	46.00	-15.38	Peak	HORIZONTAL
4	729.37	26.59	3.48	30.07	46.00	-15.93	Peak	HORIZONTAL
5	875.84	28.10	5.71	33.81	46.00	-12.19	Peak	HORIZONTAL
6	952.47	30.38	7.02	37.40	46.00	-8.60	Peak	HORIZONTAL

Remark:

- 1 The measured emissions between 9kHz to 30MHz are 20dB lower against the limit, so the result is not recorded in the report.
- 2 Measuring frequencies from the lowest internal frequency to the 1GHz.
- 3 Radiated emissions measured in frequency range from 9kHz to 1000MHz were made with an instrument detector setting 9-90kHz/110-490kHz using PK/AV and other Frequency Band using PK/QP
- 4 Measurement result within this frequency range shown “ - ” in the table above means the reading of emissions are attenuated more than 20dB below the permissible limits or the field strength is too small to be measured.

Radiated Spurious Emission Measurement Result (below 1GHz)

Operation Mode	TX MODE	Test Date	2020/01/21
Channel Number	CH Mid	Test By	Barry
Temperature	25	Pol	Ver./Hor
Humidity	65 %		

No	Freq MHz	Reading dBuV	Factor dB	Level dBuV/m	Limit dBuV/m	Margin dB	Remark	Pol V/H
1	181.32	36.49	-6.24	30.25	43.50	-13.25	Peak	VERTICAL
2	427.70	38.20	-1.48	36.72	46.00	-9.28	Peak	VERTICAL
3	499.48	41.34	-0.66	40.68	46.00	-5.32	Peak	VERTICAL
4	515.00	33.39	-0.14	33.25	46.00	-12.75	Peak	VERTICAL
5	520.82	32.61	0.08	32.69	46.00	-13.31	Peak	VERTICAL
6	641.10	33.30	1.96	35.26	46.00	-10.74	Peak	VERTICAL
1	176.47	45.67	-5.78	39.89	43.50	-3.61	Peak	HORIZONTAL
2	225.94	38.51	-6.78	31.73	46.00	-14.27	Peak	HORIZONTAL
3	492.69	35.86	-0.70	35.16	46.00	-10.84	Peak	HORIZONTAL
4	521.79	32.69	0.11	32.80	46.00	-13.20	Peak	HORIZONTAL
5	570.29	31.08	0.71	31.79	46.00	-14.21	Peak	HORIZONTAL
6	952.47	27.72	7.02	34.74	46.00	-11.26	Peak	HORIZONTAL

Remark:

- 1 The measured emissions between 9kHz to 30MHz are 20dB lower against the limit, so the result is not recorded in the report.
- 2 Measuring frequencies from the lowest internal frequency to the 1GHz.
- 3 Radiated emissions measured in frequency range from 9kHz to 1000MHz were made with an instrument detector setting 9-90kHz/110-490kHz using PK/AV and other Frequency Band using PK/QP
- 4 Measurement result within this frequency range shown “ - ” in the table above means the reading of emissions are attenuated more than 20dB below the permissible limits or the field strength is too small to be measured.

Radiated Spurious Emission Measurement Result (below 1GHz)

Operation Mode	TX MODE	Test Date	2020/01/21
Channel Number	CH High	Test By	Barry
Temperature	25	Pol	Ver./Hor
Humidity	65 %		

No	Freq MHz	Reading dBuV	Factor dB	Level dBuV/m	Limit dBuV/m	Margin dB	Remark	Pol V/H
1	188.11	40.52	-6.87	33.65	43.50	-9.85	Peak	VERTICAL
2	285.11	32.44	-4.22	28.22	46.00	-17.78	Peak	VERTICAL
3	427.70	34.82	-1.48	33.34	46.00	-12.66	Peak	VERTICAL
4	494.63	37.52	-0.68	36.84	46.00	-9.16	Peak	VERTICAL
5	517.91	30.36	-0.02	30.34	46.00	-15.66	Peak	VERTICAL
6	875.84	29.26	5.71	34.97	46.00	-11.03	Peak	VERTICAL
1	183.26	41.88	-6.42	35.46	43.50	-8.04	Peak	HORIZONTAL
2	212.36	42.37	-7.21	35.16	43.50	-8.34	Peak	HORIZONTAL
3	427.70	36.73	-1.48	35.25	46.00	-10.75	Peak	HORIZONTAL
4	491.72	41.83	-0.71	41.12	46.00	-4.88	Peak	HORIZONTAL
5	521.79	39.81	0.11	39.92	46.00	-6.08	Peak	HORIZONTAL
6	875.84	31.93	5.71	37.64	46.00	-8.36	Peak	HORIZONTAL

Remark:

- 1 The measured emissions between 9kHz to 30MHz are 20dB lower against the limit, so the result is not recorded in the report.
- 2 Measuring frequencies from the lowest internal frequency to the 1GHz.
- 3 Radiated emissions measured in frequency range from 9kHz to 1000MHz were made with an instrument detector setting 9-90kHz/110-490kHz using PK/AV and other Frequency Band using PK/QP
- 4 Measurement result within this frequency range shown “ - ” in the table above means the reading of emissions are attenuated more than 20dB below the permissible limits or the field strength is too small to be measured.

**Radiated Spurious Emission Measurement Result (below 1GHz)
(Band UNII-1 / Band UNII-2A, 802.11n HT40 mode)**

Operation Mode	TX MODE	Test Date	2020/01/21
Channel Number	CH Low	Test By	Barry
Temperature	25	Pol	Ver./Hor
Humidity	65 %		

No	Freq MHz	Reading dBuV	Factor dB	Level dBuV/m	Limit dBuV/m	Margin dB	Remark	Pol V/H
1	213.33	40.18	-7.20	32.98	43.50	-10.52	Peak	VERTICAL
2	427.70	42.38	-1.48	40.90	46.00	-5.10	Peak	VERTICAL
3	497.54	43.10	-0.67	42.43	46.00	-3.57	Peak	VERTICAL
4	522.76	43.07	0.13	43.20	46.00	-2.80	Peak	VERTICAL
5	641.10	32.30	1.96	34.26	46.00	-11.74	Peak	VERTICAL
6	875.84	30.65	5.71	36.36	46.00	-9.64	Peak	VERTICAL
1	177.44	44.47	-5.87	38.60	43.50	-4.90	Peak	HORIZONTAL
2	213.33	38.53	-7.20	31.33	43.50	-12.17	Peak	HORIZONTAL
3	494.63	36.99	-0.68	36.31	46.00	-9.69	Peak	HORIZONTAL
4	570.29	32.32	0.71	33.03	46.00	-12.97	Peak	HORIZONTAL
5	800.18	27.06	4.59	31.65	46.00	-14.35	Peak	HORIZONTAL
6	952.47	27.38	7.02	34.40	46.00	-11.60	Peak	HORIZONTAL

Remark:

- 1 The measured emissions between 9kHz to 30MHz are 20dB lower against the limit, so the result is not recorded in the report.
- 2 Measuring frequencies from the lowest internal frequency to the 1GHz.
- 3 Radiated emissions measured in frequency range from 9kHz to 1000MHz were made with an instrument detector setting 9-90kHz/110-490kHz using PK/AV and other Frequency Band using PK/QP
- 4 Measurement result within this frequency range shown “ - ” in the table above means the reading of emissions are attenuated more than 20dB below the permissible limits or the field strength is too small to be measured.

Radiated Spurious Emission Measurement Result (below 1GHz)

Operation Mode	TX MODE	Test Date	2020/01/21
Channel Number	CH Mid	Test By	Barry
Temperature	25	Pol	Ver./Hor
Humidity	65 %		

No	Freq MHz	Reading dBuV	Factor dB	Level dBuV/m	Limit dBuV/m	Margin dB	Remark	Pol V/H
1	188.11	40.83	-6.87	33.96	43.50	-9.54	Peak	VERTICAL
2	426.73	33.70	-1.51	32.19	46.00	-13.81	Peak	VERTICAL
3	499.48	37.56	-0.66	36.90	46.00	-9.10	Peak	VERTICAL
4	519.85	36.64	0.05	36.69	46.00	-9.31	Peak	VERTICAL
5	625.58	33.42	1.77	35.19	46.00	-10.81	Peak	VERTICAL
6	875.84	32.27	5.71	37.98	46.00	-8.02	Peak	VERTICAL
1	188.11	39.94	-6.87	33.07	43.50	-10.43	Peak	HORIZONTAL
2	515.97	36.64	-0.10	36.54	46.00	-9.46	Peak	HORIZONTAL
3	625.58	34.58	1.77	36.35	46.00	-9.65	Peak	HORIZONTAL
4	641.10	35.94	1.96	37.90	46.00	-8.10	Peak	HORIZONTAL
5	875.84	29.66	5.71	35.37	46.00	-10.63	Peak	HORIZONTAL
6	952.47	28.23	7.02	35.25	46.00	-10.75	Peak	HORIZONTAL

Remark:

- 1 The measured emissions between 9kHz to 30MHz are 20dB lower against the limit, so the result is not recorded in the report.
- 2 Measuring frequencies from the lowest internal frequency to the 1GHz.
- 3 Radiated emissions measured in frequency range from 9kHz to 1000MHz were made with an instrument detector setting 9-90kHz/110-490kHz using PK/AV and other Frequency Band using PK/QP
- 4 Measurement result within this frequency range shown “ - ” in the table above means the reading of emissions are attenuated more than 20dB below the permissible limits or the field strength is too small to be measured.

Radiated Spurious Emission Measurement Result (below 1GHz)

Operation Mode	TX MODE	Test Date	2020/01/21
Channel Number	CH High	Test By	Barry
Temperature	25	Pol	Ver./Hor
Humidity	65 %		

No	Freq MHz	Reading dBuV	Factor dB	Level dBuV/m	Limit dBuV/m	Margin dB	Remark	Pol V/H
1	193.93	39.77	-7.18	32.59	43.50	-10.91	Peak	VERTICAL
2	426.73	33.41	-1.51	31.90	46.00	-14.10	Peak	VERTICAL
3	519.85	37.43	0.05	37.48	46.00	-8.52	Peak	VERTICAL
4	522.76	36.91	0.13	37.04	46.00	-8.96	Peak	VERTICAL
5	569.32	29.59	0.69	30.28	46.00	-15.72	Peak	VERTICAL
6	952.47	27.53	7.02	34.55	46.00	-11.45	Peak	VERTICAL
1	186.17	40.79	-6.69	34.10	43.50	-9.40	Peak	HORIZONTAL
2	191.02	40.51	-7.08	33.43	43.50	-10.07	Peak	HORIZONTAL
3	497.54	33.82	-0.67	33.15	46.00	-12.85	Peak	HORIZONTAL
4	625.58	34.78	1.77	36.55	46.00	-9.45	Peak	HORIZONTAL
5	641.10	33.59	1.96	35.55	46.00	-10.45	Peak	HORIZONTAL
6	875.84	29.56	5.71	35.27	46.00	-10.73	Peak	HORIZONTAL

Remark:

- 1 The measured emissions between 9kHz to 30MHz are 20dB lower against the limit, so the result is not recorded in the report.
- 2 Measuring frequencies from the lowest internal frequency to the 1GHz.
- 3 Radiated emissions measured in frequency range from 9kHz to 1000MHz were made with an instrument detector setting 9-90kHz/110-490kHz using PK/AV and other Frequency Band using PK/QP
- 4 Measurement result within this frequency range shown “ - ” in the table above means the reading of emissions are attenuated more than 20dB below the permissible limits or the field strength is too small to be measured.

**Radiated Spurious Emission Measurement Result (below 1GHz)
(Band UNII-1 / Band UNII-2A, 802.11ac VHT80 mode)**

Operation Mode	TX MODE	Test Date	2020/01/21
Channel Number	CH Low	Test By	Barry
Temperature	25	Pol	Ver./Hor
Humidity	65 %		

No	Freq MHz	Reading dBuV	Factor dB	Level dBuV/m	Limit dBuV/m	Margin dB	Remark	Pol V/H
1	189.08	41.73	-6.96	34.77	43.50	-8.73	Peak	VERTICAL
2	426.73	37.09	-1.51	35.58	46.00	-10.42	Peak	VERTICAL
3	492.69	39.87	-0.70	39.17	46.00	-6.83	Peak	VERTICAL
4	625.58	34.26	1.77	36.03	46.00	-9.97	Peak	VERTICAL
5	875.84	31.07	5.71	36.78	46.00	-9.22	Peak	VERTICAL
6	952.47	29.30	7.02	36.32	46.00	-9.68	Peak	VERTICAL
1	188.11	42.37	-6.87	35.50	43.50	-8.00	Peak	HORIZONTAL
2	427.70	35.01	-1.48	33.53	46.00	-12.47	Peak	HORIZONTAL
3	489.78	38.84	-0.72	38.12	46.00	-7.88	Peak	HORIZONTAL
4	497.54	34.57	-0.67	33.90	46.00	-12.10	Peak	HORIZONTAL
5	518.88	34.54	0.02	34.56	46.00	-11.44	Peak	HORIZONTAL
6	951.50	28.49	7.00	35.49	46.00	-10.51	Peak	HORIZONTAL

Remark:

- 1 The measured emissions between 9kHz to 30MHz are 20dB lower against the limit, so the result is not recorded in the report.
- 2 Measuring frequencies from the lowest internal frequency to the 1GHz.
- 3 Radiated emissions measured in frequency range from 9kHz to 1000MHz were made with an instrument detector setting 9-90kHz/110-490kHz using PK/AV and other Frequency Band using PK/QP
- 4 Measurement result within this frequency range shown “ - ” in the table above means the reading of emissions are attenuated more than 20dB below the permissible limits or the field strength is too small to be measured.

Radiated Spurious Emission Measurement Result (below 1GHz)

Operation Mode	TX MODE	Test Date	2020/01/21
Channel Number	CH High	Test By	Barry
Temperature	25	Pol	Ver./Hor
Humidity	65 %		

No	Freq MHz	Reading dBuV	Factor dB	Level dBuV/m	Limit dBuV/m	Margin dB	Remark	Pol V/H
1	427.70	42.25	-1.48	40.77	46.00	-5.23	Peak	VERTICAL
2	499.48	37.33	-0.66	36.67	46.00	-9.33	Peak	VERTICAL
3	641.10	35.24	1.96	37.20	46.00	-8.80	Peak	VERTICAL
4	854.50	29.13	5.41	34.54	46.00	-11.46	Peak	VERTICAL
5	875.84	31.13	5.71	36.84	46.00	-9.16	Peak	VERTICAL
6	927.25	31.99	6.52	38.51	46.00	-7.49	Peak	VERTICAL
1	175.50	44.38	-5.70	38.68	43.50	-4.82	Peak	HORIZONTAL
2	191.02	40.91	-7.08	33.83	43.50	-9.67	Peak	HORIZONTAL
3	224.97	36.74	-6.84	29.90	46.00	-16.10	Peak	HORIZONTAL
4	499.48	36.73	-0.66	36.07	46.00	-9.93	Peak	HORIZONTAL
5	513.06	35.09	-0.22	34.87	46.00	-11.13	Peak	HORIZONTAL
6	569.32	32.51	0.69	33.20	46.00	-12.80	Peak	HORIZONTAL

Remark:

- 1 The measured emissions between 9kHz to 30MHz are 20dB lower against the limit, so the result is not recorded in the report.
- 2 Measuring frequencies from the lowest internal frequency to the 1GHz.
- 3 Radiated emissions measured in frequency range from 9kHz to 1000MHz were made with an instrument detector setting 9-90kHz/110-490kHz using PK/AV and other Frequency Band using PK/QP
- 4 Measurement result within this frequency range shown “ - ” in the table above means the reading of emissions are attenuated more than 20dB below the permissible limits or the field strength is too small to be measured.

**Radiated Spurious Emission Measurement Result (below 1GHz)
(Band UNII-2C, 802.11a mode)**

Operation Mode	TX MODE	Test Date	2020/01/21
Channel Number	CH Low	Test By	Barry
Temperature	25	Pol	Ver./Hor
Humidity	65 %		

No	Freq MHz	Reading dBuV	Factor dB	Level dBuV/m	Limit dBuV/m	Margin dB	Remark	Pol V/H
1	178.41	42.15	-5.97	36.18	43.50	-7.32	Peak	VERTICAL
2	193.93	41.16	-7.18	33.98	43.50	-9.52	Peak	VERTICAL
3	426.73	36.83	-1.51	35.32	46.00	-10.68	Peak	VERTICAL
4	498.51	35.77	-0.65	35.12	46.00	-10.88	Peak	VERTICAL
5	770.11	29.24	4.27	33.51	46.00	-12.49	Peak	VERTICAL
6	875.84	36.13	5.71	41.84	46.00	-4.16	Peak	VERTICAL
1	170.65	36.29	-5.25	31.04	43.50	-12.46	Peak	HORIZONTAL
2	225.94	37.44	-6.78	30.66	46.00	-15.34	Peak	HORIZONTAL
3	500.45	31.18	-0.64	30.54	46.00	-15.46	Peak	HORIZONTAL
4	625.58	36.68	1.77	38.45	46.00	-7.55	Peak	HORIZONTAL
5	641.10	31.92	1.96	33.88	46.00	-12.12	Peak	HORIZONTAL
6	916.58	28.88	6.26	35.14	46.00	-10.86	Peak	HORIZONTAL

Remark:

- 1 The measured emissions between 9kHz to 30MHz are 20dB lower against the limit, so the result is not recorded in the report.
- 2 Measuring frequencies from the lowest internal frequency to the 1GHz.
- 3 Radiated emissions measured in frequency range from 9kHz to 1000MHz were made with an instrument detector setting 9-90kHz/110-490kHz using PK/AV and other Frequency Band using PK/QP
- 4 Measurement result within this frequency range shown “ - ” in the table above means the reading of emissions are attenuated more than 20dB below the permissible limits or the field strength is too small to be measured.

Radiated Spurious Emission Measurement Result (below 1GHz)

Operation Mode	TX MODE	Test Date	2020/01/21
Channel Number	CH Mid	Test By	Barry
Temperature	25	Pol	Ver./Hor
Humidity	65 %		

No	Freq MHz	Reading dBuV	Factor dB	Level dBuV/m	Limit dBuV/m	Margin dB	Remark	Pol V/H
1	178.41	41.68	-5.97	35.71	43.50	-7.79	Peak	VERTICAL
2	196.84	41.40	-7.27	34.13	43.50	-9.37	Peak	VERTICAL
3	354.95	34.39	-2.91	31.48	46.00	-14.52	Peak	VERTICAL
4	426.73	38.10	-1.51	36.59	46.00	-9.41	Peak	VERTICAL
5	500.45	32.37	-0.64	31.73	46.00	-14.27	Peak	VERTICAL
6	875.84	36.68	5.71	42.39	46.00	-3.61	Peak	VERTICAL
1	170.65	35.97	-5.25	30.72	43.50	-12.78	Peak	HORIZONTAL
2	225.94	36.09	-6.78	29.31	46.00	-16.69	Peak	HORIZONTAL
3	570.29	29.92	0.71	30.63	46.00	-15.37	Peak	HORIZONTAL
4	625.58	36.67	1.77	38.44	46.00	-7.56	Peak	HORIZONTAL
5	750.71	30.23	3.99	34.22	46.00	-11.78	Peak	HORIZONTAL
6	861.29	30.54	5.50	36.04	46.00	-9.96	Peak	HORIZONTAL

Remark:

- 1 The measured emissions between 9kHz to 30MHz are 20dB lower against the limit, so the result is not recorded in the report.
- 2 Measuring frequencies from the lowest internal frequency to the 1GHz.
- 3 Radiated emissions measured in frequency range from 9kHz to 1000MHz were made with an instrument detector setting 9-90kHz/110-490kHz using PK/AV and other Frequency Band using PK/QP
- 4 Measurement result within this frequency range shown “ - ” in the table above means the reading of emissions are attenuated more than 20dB below the permissible limits or the field strength is too small to be measured.

Radiated Spurious Emission Measurement Result (below 1GHz)

Operation Mode	TX MODE	Test Date	2020/01/21
Channel Number	CH High	Test By	Barry
Temperature	25	Pol	Ver./Hor
Humidity	65 %		

No	Freq MHz	Reading dBuV	Factor dB	Level dBuV/m	Limit dBuV/m	Margin dB	Remark	Pol V/H
1	175.50	42.20	-5.70	36.50	43.50	-7.00	Peak	VERTICAL
2	196.84	41.66	-7.27	34.39	43.50	-9.11	Peak	VERTICAL
3	427.70	36.87	-1.48	35.39	46.00	-10.61	Peak	VERTICAL
4	498.51	36.72	-0.65	36.07	46.00	-9.93	Peak	VERTICAL
5	569.32	33.77	0.69	34.46	46.00	-11.54	Peak	VERTICAL
6	875.84	37.02	5.71	42.73	46.00	-3.27	Peak	VERTICAL
1	594.54	29.34	1.41	30.75	46.00	-15.25	Peak	HORIZONTAL
2	625.58	37.18	1.77	38.95	46.00	-7.05	Peak	HORIZONTAL
3	641.10	33.40	1.96	35.36	46.00	-10.64	Peak	HORIZONTAL
4	750.71	29.14	3.99	33.13	46.00	-12.87	Peak	HORIZONTAL
5	840.92	28.85	5.29	34.14	46.00	-11.86	Peak	HORIZONTAL
6	937.92	29.63	6.63	36.26	46.00	-9.74	Peak	HORIZONTAL

Remark:

- 1 The measured emissions between 9kHz to 30MHz are 20dB lower against the limit, so the result is not recorded in the report.
- 2 Measuring frequencies from the lowest internal frequency to the 1GHz.
- 3 Radiated emissions measured in frequency range from 9kHz to 1000MHz were made with an instrument detector setting 9-90kHz/110-490kHz using PK/AV and other Frequency Band using PK/QP
- 4 Measurement result within this frequency range shown “ - ” in the table above means the reading of emissions are attenuated more than 20dB below the permissible limits or the field strength is too small to be measured.

**Radiated Spurious Emission Measurement Result (below 1GHz)
(Band UNII-2C, 802.11n HT40 mode)**

Operation Mode	TX MODE	Test Date	2020/01/21
Channel Number	CH Low	Test By	Barry
Temperature	25	Pol	Ver./Hor
Humidity	65 %		

No	Freq MHz	Reading dBuV	Factor dB	Level dBuV/m	Limit dBuV/m	Margin dB	Remark	Pol V/H
1	375.32	31.47	-2.39	29.08	46.00	-16.92	Peak	VERTICAL
2	570.29	32.83	0.71	33.54	46.00	-12.46	Peak	VERTICAL
3	625.58	32.54	1.77	34.31	46.00	-11.69	Peak	VERTICAL
4	720.64	29.59	3.26	32.85	46.00	-13.15	Peak	VERTICAL
5	833.16	29.36	5.18	34.54	46.00	-11.46	Peak	VERTICAL
6	971.87	29.89	7.30	37.19	54.00	-16.81	Peak	VERTICAL
1	177.44	41.92	-5.87	36.05	43.50	-7.45	Peak	HORIZONTAL
2	213.33	40.13	-7.20	32.93	43.50	-10.57	Peak	HORIZONTAL
3	426.73	35.50	-1.51	33.99	46.00	-12.01	Peak	HORIZONTAL
4	498.51	33.48	-0.65	32.83	46.00	-13.17	Peak	HORIZONTAL
5	625.58	32.17	1.77	33.94	46.00	-12.06	Peak	HORIZONTAL
6	887.48	29.43	5.87	35.30	46.00	-10.70	Peak	HORIZONTAL

Remark:

- 1 The measured emissions between 9kHz to 30MHz are 20dB lower against the limit, so the result is not recorded in the report.
- 2 Measuring frequencies from the lowest internal frequency to the 1GHz.
- 3 Radiated emissions measured in frequency range from 9kHz to 1000MHz were made with an instrument detector setting 9-90kHz/110-490kHz using PK/AV and other Frequency Band using PK/QP
- 4 Measurement result within this frequency range shown “ - ” in the table above means the reading of emissions are attenuated more than 20dB below the permissible limits or the field strength is too small to be measured.

Radiated Spurious Emission Measurement Result (below 1GHz)

Operation Mode	TX MODE	Test Date	2020/01/21
Channel Number	CH Mid	Test By	Barry
Temperature	25	Pol	Ver./Hor
Humidity	65 %		

No	Freq MHz	Reading dBuV	Factor dB	Level dBuV/m	Limit dBuV/m	Margin dB	Remark	Pol V/H
1	569.32	32.27	0.69	32.96	46.00	-13.04	Peak	VERTICAL
2	625.58	33.76	1.77	35.53	46.00	-10.47	Peak	VERTICAL
3	681.84	30.42	2.65	33.07	46.00	-12.93	Peak	VERTICAL
4	812.79	29.27	4.88	34.15	46.00	-11.85	Peak	VERTICAL
5	856.44	29.72	5.42	35.14	46.00	-10.86	Peak	VERTICAL
6	946.65	29.85	6.87	36.72	46.00	-9.28	Peak	VERTICAL
1	174.53	42.22	-5.60	36.62	43.50	-6.88	Peak	HORIZONTAL
2	186.17	41.15	-6.69	34.46	43.50	-9.04	Peak	HORIZONTAL
3	426.73	37.88	-1.51	36.37	46.00	-9.63	Peak	HORIZONTAL
4	625.58	32.12	1.77	33.89	46.00	-12.11	Peak	HORIZONTAL
5	800.18	29.91	4.59	34.50	46.00	-11.50	Peak	HORIZONTAL
6	847.71	29.94	5.32	35.26	46.00	-10.74	Peak	HORIZONTAL

Remark:

- 1 The measured emissions between 9kHz to 30MHz are 20dB lower against the limit, so the result is not recorded in the report.
- 2 Measuring frequencies from the lowest internal frequency to the 1GHz.
- 3 Radiated emissions measured in frequency range from 9kHz to 1000MHz were made with an instrument detector setting 9-90kHz/110-490kHz using PK/AV and other Frequency Band using PK/QP
- 4 Measurement result within this frequency range shown “ - ” in the table above means the reading of emissions are attenuated more than 20dB below the permissible limits or the field strength is too small to be measured.

Radiated Spurious Emission Measurement Result (below 1GHz)

Operation Mode	TX MODE	Test Date	2020/01/21
Channel Number	CH High	Test By	Barry
Temperature	25	Pol	Ver./Hor
Humidity	65 %		

No	Freq MHz	Reading dBuV	Factor dB	Level dBuV/m	Limit dBuV/m	Margin dB	Remark	Pol V/H
1	355.92	33.03	-2.88	30.15	46.00	-15.85	Peak	VERTICAL
2	569.32	31.50	0.69	32.19	46.00	-13.81	Peak	VERTICAL
3	625.58	34.55	1.77	36.32	46.00	-9.68	Peak	VERTICAL
4	733.25	29.19	3.60	32.79	46.00	-13.21	Peak	VERTICAL
5	766.23	29.33	4.25	33.58	46.00	-12.42	Peak	VERTICAL
6	847.71	29.27	5.32	34.59	46.00	-11.41	Peak	VERTICAL
1	175.50	41.66	-5.70	35.96	43.50	-7.54	Peak	HORIZONTAL
2	213.33	39.68	-7.20	32.48	43.50	-11.02	Peak	HORIZONTAL
3	427.70	36.03	-1.48	34.55	46.00	-11.45	Peak	HORIZONTAL
4	625.58	34.03	1.77	35.80	46.00	-10.20	Peak	HORIZONTAL
5	846.74	29.27	5.31	34.58	46.00	-11.42	Peak	HORIZONTAL
6	947.62	29.09	6.91	36.00	46.00	-10.00	Peak	HORIZONTAL

Remark:

- 1 The measured emissions between 9kHz to 30MHz are 20dB lower against the limit, so the result is not recorded in the report.
- 2 Measuring frequencies from the lowest internal frequency to the 1GHz.
- 3 Radiated emissions measured in frequency range from 9kHz to 1000MHz were made with an instrument detector setting 9-90kHz/110-490kHz using PK/AV and other Frequency Band using PK/QP
- 4 Measurement result within this frequency range shown “ - ” in the table above means the reading of emissions are attenuated more than 20dB below the permissible limits or the field strength is too small to be measured.

**Radiated Spurious Emission Measurement Result (below 1GHz)
(Band UNII-2C, 802.11ac VHT80 mode)**

Operation Mode	TX MODE	Test Date	2020/01/21
Channel Number	CH Low	Test By	Barry
Temperature	25	Pol	Ver./Hor
Humidity	65 %		

No	Freq MHz	Reading dBuV	Factor dB	Level dBuV/m	Limit dBuV/m	Margin dB	Remark	Pol V/H
1	174.53	36.64	-5.60	31.04	43.50	-12.46	Peak	VERTICAL
2	569.32	33.51	0.69	34.20	46.00	-11.80	Peak	VERTICAL
3	641.10	31.85	1.96	33.81	46.00	-12.19	Peak	VERTICAL
4	807.94	29.71	4.79	34.50	46.00	-11.50	Peak	VERTICAL
5	856.44	29.46	5.42	34.88	46.00	-11.12	Peak	VERTICAL
6	878.75	30.13	5.76	35.89	46.00	-10.11	Peak	VERTICAL
1	174.53	39.76	-5.60	34.16	43.50	-9.34	Peak	HORIZONTAL
2	213.33	38.85	-7.20	31.65	43.50	-11.85	Peak	HORIZONTAL
3	426.73	38.15	-1.51	36.64	46.00	-9.36	Peak	HORIZONTAL
4	569.32	33.24	0.69	33.93	46.00	-12.07	Peak	HORIZONTAL
5	625.58	34.21	1.77	35.98	46.00	-10.02	Peak	HORIZONTAL
6	914.64	30.34	6.22	36.56	46.00	-9.44	Peak	HORIZONTAL

Remark:

- 1 The measured emissions between 9kHz to 30MHz are 20dB lower against the limit, so the result is not recorded in the report.
- 2 Measuring frequencies from the lowest internal frequency to the 1GHz.
- 3 Radiated emissions measured in frequency range from 9kHz to 1000MHz were made with an instrument detector setting 9-90kHz/110-490kHz using PK/AV and other Frequency Band using PK/QP
- 4 Measurement result within this frequency range shown “ - ” in the table above means the reading of emissions are attenuated more than 20dB below the permissible limits or the field strength is too small to be measured.

Operation Mode	TX MODE	Test Date	2020/01/21
Channel Number	CH High	Test By	Barry
Temperature	25	Pol	Ver./Hor
Humidity	65 %		

No	Freq MHz	Reading dBuV	Factor dB	Level dBuV/m	Limit dBuV/m	Margin dB	Remark	Pol V/H
1	427.70	33.50	-1.48	32.02	46.00	-13.98	Peak	VERTICAL
2	570.29	34.95	0.71	35.66	46.00	-10.34	Peak	VERTICAL
3	625.58	32.88	1.77	34.65	46.00	-11.35	Peak	VERTICAL
4	641.10	33.02	1.96	34.98	46.00	-11.02	Peak	VERTICAL
5	832.19	30.04	5.17	35.21	46.00	-10.79	Peak	VERTICAL
6	875.84	30.55	5.71	36.26	46.00	-9.74	Peak	VERTICAL
1	175.50	39.92	-5.70	34.22	43.50	-9.28	Peak	HORIZONTAL
2	426.73	37.92	-1.51	36.41	46.00	-9.59	Peak	HORIZONTAL
3	570.29	32.99	0.71	33.70	46.00	-12.30	Peak	HORIZONTAL
4	625.58	33.02	1.77	34.79	46.00	-11.21	Peak	HORIZONTAL
5	791.45	30.33	4.47	34.80	46.00	-11.20	Peak	HORIZONTAL
6	851.59	30.10	5.36	35.46	46.00	-10.54	Peak	HORIZONTAL

Remark:

- 1 The measured emissions between 9kHz to 30MHz are 20dB lower against the limit, so the result is not recorded in the report.
- 2 Measuring frequencies from the lowest internal frequency to the 1GHz.
- 3 Radiated emissions measured in frequency range from 9kHz to 1000MHz were made with an instrument detector setting 9-90kHz/110-490kHz using PK/AV and other Frequency Band using PK/QP
- 4 Measurement result within this frequency range shown “ - ” in the table above means the reading of emissions are attenuated more than 20dB below the permissible limits or the field strength is too small to be measured.

Radiated Spurious Emission Measurement Result (below 1GHz)

(Band UNII-3, 802.11a mode)

Operation Mode	TX MODE	Test Date	2020/01/21
Channel Number	CH Low	Test By	Barry
Temperature	25	Pol	Ver./Hor
Humidity	65 %		

No	Freq MHz	Reading dBuV	Factor dB	Level dBuV/m	Limit dBuV/m	Margin dB	Remark	Pol V/H
1	355.92	37.32	-2.88	34.44	46.00	-11.56	Peak	VERTICAL
2	427.70	33.54	-1.48	32.06	46.00	-13.94	Peak	VERTICAL
3	570.29	33.00	0.71	33.71	46.00	-12.29	Peak	VERTICAL
4	625.58	33.10	1.77	34.87	46.00	-11.13	Peak	VERTICAL
5	642.07	30.04	1.97	32.01	46.00	-13.99	Peak	VERTICAL
6	875.84	31.38	5.71	37.09	46.00	-8.91	Peak	VERTICAL
1	180.35	40.27	-6.14	34.13	43.50	-9.37	Peak	HORIZONTAL
2	427.70	38.26	-1.48	36.78	46.00	-9.22	Peak	HORIZONTAL
3	569.32	33.61	0.69	34.30	46.00	-11.70	Peak	HORIZONTAL
4	625.58	34.31	1.77	36.08	46.00	-9.92	Peak	HORIZONTAL
5	749.74	31.35	3.97	35.32	46.00	-10.68	Peak	HORIZONTAL
6	843.83	29.98	5.31	35.29	46.00	-10.71	Peak	HORIZONTAL

Remark:

- 1 The measured emissions between 9kHz to 30MHz are 20dB lower against the limit, so the result is not recorded in the report.
- 2 Measuring frequencies from the lowest internal frequency to the 1GHz.
- 3 Radiated emissions measured in frequency range from 9kHz to 1000MHz were made with an instrument detector setting 9-90kHz/110-490kHz using PK/AV and other Frequency Band using PK/QP
- 4 Measurement result within this frequency range shown “ - ” in the table above means the reading of emissions are attenuated more than 20dB below the permissible limits or the field strength is too small to be measured.

Radiated Spurious Emission Measurement Result (below 1GHz)

Operation Mode	TX MODE	Test Date	2020/01/21
Channel Number	CH Mid	Test By	Barry
Temperature	25	Pol	Ver./Hor
Humidity	65 %		

No	Freq MHz	Reading dBuV	Factor dB	Level dBuV/m	Limit dBuV/m	Margin dB	Remark	Pol V/H
1	427.70	33.71	-1.48	32.23	46.00	-13.77	Peak	VERTICAL
2	570.29	33.51	0.71	34.22	46.00	-11.78	Peak	VERTICAL
3	625.58	34.16	1.77	35.93	46.00	-10.07	Peak	VERTICAL
4	753.62	29.79	4.06	33.85	46.00	-12.15	Peak	VERTICAL
5	875.84	31.21	5.71	36.92	46.00	-9.08	Peak	VERTICAL
6	934.04	30.12	6.62	36.74	46.00	-9.26	Peak	VERTICAL
1	174.53	39.91	-5.60	34.31	43.50	-9.19	Peak	HORIZONTAL
2	426.73	39.43	-1.51	37.92	46.00	-8.08	Peak	HORIZONTAL
3	500.45	36.45	-0.64	35.81	46.00	-10.19	Peak	HORIZONTAL
4	570.29	34.19	0.71	34.90	46.00	-11.10	Peak	HORIZONTAL
5	625.58	33.98	1.77	35.75	46.00	-10.25	Peak	HORIZONTAL
6	907.85	29.50	6.09	35.59	46.00	-10.41	Peak	HORIZONTAL

Remark:

- 1 The measured emissions between 9kHz to 30MHz are 20dB lower against the limit, so the result is not recorded in the report.
- 2 Measuring frequencies from the lowest internal frequency to the 1GHz.
- 3 Radiated emissions measured in frequency range from 9kHz to 1000MHz were made with an instrument detector setting 9-90kHz/110-490kHz using PK/AV and other Frequency Band using PK/QP
- 4 Measurement result within this frequency range shown “ - ” in the table above means the reading of emissions are attenuated more than 20dB below the permissible limits or the field strength is too small to be measured.

Radiated Spurious Emission Measurement Result (below 1GHz)

Operation Mode	TX MODE	Test Date	2020/01/21
Channel Number	CH High	Test By	Barry
Temperature	25	Pol	Ver./Hor
Humidity	65 %		

No	Freq MHz	Reading dBuV	Factor dB	Level dBuV/m	Limit dBuV/m	Margin dB	Remark	Pol V/H
1	177.44	42.95	-5.87	37.08	43.50	-6.42	Peak	VERTICAL
2	191.02	41.57	-7.08	34.49	43.50	-9.01	Peak	VERTICAL
3	426.73	38.57	-1.51	37.06	46.00	-8.94	Peak	VERTICAL
4	569.32	32.27	0.69	32.96	46.00	-13.04	Peak	VERTICAL
5	822.49	31.15	5.02	36.17	46.00	-9.83	Peak	VERTICAL
6	875.84	35.50	5.71	41.21	46.00	-4.79	Peak	VERTICAL
1	517.91	30.91	-0.02	30.89	46.00	-15.11	Peak	HORIZONTAL
2	625.58	34.83	1.77	36.60	46.00	-9.40	Peak	HORIZONTAL
3	641.10	32.34	1.96	34.30	46.00	-11.70	Peak	HORIZONTAL
4	814.73	30.18	4.92	35.10	46.00	-10.90	Peak	HORIZONTAL
5	829.28	30.82	5.12	35.94	46.00	-10.06	Peak	HORIZONTAL
6	927.25	29.01	6.52	35.53	46.00	-10.47	Peak	HORIZONTAL

Remark:

- 1 The measured emissions between 9kHz to 30MHz are 20dB lower against the limit, so the result is not recorded in the report.
- 2 Measuring frequencies from the lowest internal frequency to the 1GHz.
- 3 Radiated emissions measured in frequency range from 9kHz to 1000MHz were made with an instrument detector setting 9-90kHz/110-490kHz using PK/AV and other Frequency Band using PK/QP
- 4 Measurement result within this frequency range shown “ - ” in the table above means the reading of emissions are attenuated more than 20dB below the permissible limits or the field strength is too small to be measured.

**Radiated Spurious Emission Measurement Result (below 1GHz)
(Band UNII-3, 802.11n HT40 mode)**

Operation Mode	TX MODE	Test Date	2020/01/21
Channel Number	CH Low	Test By	Barry
Temperature	25	Pol	Ver./Hor
Humidity	65 %		

No	Freq MHz	Reading dBuV	Factor dB	Level dBuV/m	Limit dBuV/m	Margin dB	Remark	Pol V/H
1	174.53	42.18	-5.60	36.58	43.50	-6.92	Peak	VERTICAL
2	395.69	33.48	-2.08	31.40	46.00	-14.60	Peak	VERTICAL
3	427.70	36.68	-1.48	35.20	46.00	-10.80	Peak	VERTICAL
4	500.45	32.23	-0.64	31.59	46.00	-14.41	Peak	VERTICAL
5	826.37	29.55	5.08	34.63	46.00	-11.37	Peak	VERTICAL
6	875.84	35.39	5.71	41.10	46.00	-4.90	Peak	VERTICAL
1	172.59	36.16	-5.43	30.73	43.50	-12.77	Peak	HORIZONTAL
2	625.58	32.87	1.77	34.64	46.00	-11.36	Peak	HORIZONTAL
3	641.10	30.70	1.96	32.66	46.00	-13.34	Peak	HORIZONTAL
4	699.30	29.66	3.14	32.80	46.00	-13.20	Peak	HORIZONTAL
5	819.58	30.62	4.98	35.60	46.00	-10.40	Peak	HORIZONTAL
6	949.56	28.59	6.97	35.56	46.00	-10.44	Peak	HORIZONTAL

Remark:

- 1 The measured emissions between 9kHz to 30MHz are 20dB lower against the limit, so the result is not recorded in the report.
- 2 Measuring frequencies from the lowest internal frequency to the 1GHz.
- 3 Radiated emissions measured in frequency range from 9kHz to 1000MHz were made with an instrument detector setting 9-90kHz/110-490kHz using PK/AV and other Frequency Band using PK/QP
- 4 Measurement result within this frequency range shown “ - ” in the table above means the reading of emissions are attenuated more than 20dB below the permissible limits or the field strength is too small to be measured.

Radiated Spurious Emission Measurement Result (below 1GHz)

Operation Mode	TX MODE	Test Date	2020/04/07
Channel Number	CH Mid	Test By	Barry
Temperature	25	Pol	Ver./Hor
Humidity	65 %		

No	Freq MHz	Reading dBuV	Factor dB	Level dBuV/m	Limit dBuV/m	Margin dB	Remark	Pol V/H
1	177.44	42.44	-5.87	36.57	43.50	-6.93	Peak	VERTICAL
2	427.70	38.07	-1.48	36.59	46.00	-9.41	Peak	VERTICAL
3	640.13	31.03	1.96	32.99	46.00	-13.01	Peak	VERTICAL
4	769.14	29.67	4.26	33.93	46.00	-12.07	Peak	VERTICAL
5	806.97	29.31	4.76	34.07	46.00	-11.93	Peak	VERTICAL
6	875.84	36.11	5.71	41.82	46.00	-4.18	Peak	VERTICAL
1	174.53	35.17	-5.60	29.57	43.50	-13.93	Peak	HORIZONTAL
2	603.27	29.89	1.56	31.45	46.00	-14.55	Peak	HORIZONTAL
3	625.58	34.84	1.77	36.61	46.00	-9.39	Peak	HORIZONTAL
4	737.13	29.50	3.73	33.23	46.00	-12.77	Peak	HORIZONTAL
5	821.52	30.40	5.02	35.42	46.00	-10.58	Peak	HORIZONTAL
6	927.25	28.57	6.52	35.09	46.00	-10.91	Peak	HORIZONTAL

Remark:

- 1 The measured emissions between 9kHz to 30MHz are 20dB lower against the limit, so the result is not recorded in the report.
- 2 Measuring frequencies from the lowest internal frequency to the 1GHz.
- 3 Radiated emissions measured in frequency range from 9kHz to 1000MHz were made with an instrument detector setting 9-90kHz/110-490kHz using PK/AV and other Frequency Band using PK/QP
- 4 Measurement result within this frequency range shown “ - ” in the table above means the reading of emissions are attenuated more than 20dB below the permissible limits or the field strength is too small to be measured.

Radiated Spurious Emission Measurement Result (below 1GHz)

Operation Mode	TX MODE	Test Date	2020/04/07
Channel Number	CH High	Test By	Barry
Temperature	25	Pol	Ver./Hor
Humidity	65 %		

No	Freq MHz	Reading dBuV	Factor dB	Level dBuV/m	Limit dBuV/m	Margin dB	Remark	Pol V/H
1	356.89	35.11	-2.87	32.24	46.00	-13.76	Peak	VERTICAL
2	427.70	34.60	-1.48	33.12	46.00	-12.88	Peak	VERTICAL
3	570.29	34.44	0.71	35.15	46.00	-10.85	Peak	VERTICAL
4	625.58	33.10	1.77	34.87	46.00	-11.13	Peak	VERTICAL
5	642.07	31.99	1.97	33.96	46.00	-12.04	Peak	VERTICAL
6	875.84	31.75	5.71	37.46	46.00	-8.54	Peak	VERTICAL
1	177.44	40.88	-5.87	35.01	43.50	-8.49	Peak	HORIZONTAL
2	185.20	39.91	-6.60	33.31	43.50	-10.19	Peak	HORIZONTAL
3	427.70	38.64	-1.48	37.16	46.00	-8.84	Peak	HORIZONTAL
4	570.29	34.22	0.71	34.93	46.00	-11.07	Peak	HORIZONTAL
5	625.58	33.64	1.77	35.41	46.00	-10.59	Peak	HORIZONTAL
6	854.50	30.05	5.41	35.46	46.00	-10.54	Peak	HORIZONTAL

Remark:

- 1 The measured emissions between 9kHz to 30MHz are 20dB lower against the limit, so the result is not recorded in the report.
- 2 Measuring frequencies from the lowest internal frequency to the 1GHz.
- 3 Radiated emissions measured in frequency range from 9kHz to 1000MHz were made with an instrument detector setting 9-90kHz/110-490kHz using PK/AV and other Frequency Band using PK/QP
- 4 Measurement result within this frequency range shown “ - ” in the table above means the reading of emissions are attenuated more than 20dB below the permissible limits or the field strength is too small to be measured.

**Radiated Spurious Emission Measurement Result (below 1GHz)
(Band UNII-3, 802.11ac VHT80 mode)**

Operation Mode	TX MODE	Test Date	2020/04/07
Channel Number	CH Low	Test By	Barry
Temperature	25	Pol	Ver./Hor
Humidity	65 %		

No	Freq MHz	Reading dBuV	Factor dB	Level dBuV/m	Limit dBuV/m	Margin dB	Remark	Pol V/H
1	174.53	36.29	-5.60	30.69	43.50	-12.81	Peak	VERTICAL
2	427.70	33.54	-1.48	32.06	46.00	-13.94	Peak	VERTICAL
3	570.29	34.04	0.71	34.75	46.00	-11.25	Peak	VERTICAL
4	625.58	33.66	1.77	35.43	46.00	-10.57	Peak	VERTICAL
5	639.16	31.55	1.95	33.50	46.00	-12.50	Peak	VERTICAL
6	875.84	30.90	5.71	36.61	46.00	-9.39	Peak	VERTICAL
1	177.44	40.72	-5.87	34.85	43.50	-8.65	Peak	HORIZONTAL
2	427.70	40.15	-1.48	38.67	46.00	-7.33	Peak	HORIZONTAL
3	570.29	34.56	0.71	35.27	46.00	-10.73	Peak	HORIZONTAL
4	625.58	32.88	1.77	34.65	46.00	-11.35	Peak	HORIZONTAL
5	831.22	30.19	5.16	35.35	46.00	-10.65	Peak	HORIZONTAL
6	838.01	30.72	5.26	35.98	46.00	-10.02	Peak	HORIZONTAL

Remark:

- 1 The measured emissions between 9kHz to 30MHz are 20dB lower against the limit, so the result is not recorded in the report.
- 2 Measuring frequencies from the lowest internal frequency to the 1GHz.
- 3 Radiated emissions measured in frequency range from 9kHz to 1000MHz were made with an instrument detector setting 9-90kHz/110-490kHz using PK/AV and other Frequency Band using PK/QP
- 4 Measurement result within this frequency range shown “ - ” in the table above means the reading of emissions are attenuated more than 20dB below the permissible limits or the field strength is too small to be measured.

Dipole Ant

Radiated Spurious Emission Measurement Result (above 1GHz)

(Band UNII-1 / Band UNII-2A, 802.11a mode)

Operation Mode	TX MODE	Test Date	2020/04/07
Channel Number	CH Low	Test By	Barry
Temperature	25	Humidity	60 %

No	Freq MHz	Reading dBuV	Factor dB	Level dBuV/m	Limit dBuV/m	Margin dB	Remark	Pol V/H
1	1210.00	54.00	-19.78	34.22	74.00	-39.78	Peak	VERTICAL
2	4878.00	51.96	-9.02	42.94	74.00	-31.06	Peak	VERTICAL
3	10360.00	35.32	4.18	39.50	68.20	-28.70	Peak	VERTICAL
4	15540.00	33.18	7.94	41.12	74.00	-32.88	Peak	VERTICAL
1	2519.00	48.37	-15.64	32.73	68.20	-35.47	Peak	HORIZONTAL
2	3618.00	47.82	-13.20	34.62	74.00	-39.38	Peak	HORIZONTAL
3	10360.00	36.78	4.18	40.96	68.20	-27.24	Peak	HORIZONTAL
4	15540.00	34.14	7.94	42.08	74.00	-31.92	Peak	HORIZONTAL

Remark:

- 1 Field strength limits for frequency above 1000MHz are based on average limits. However, Peak mode field strength shall not exceed the average limits specified plus 20dB.
- 2 Measurement of data within this frequency range shown “ - ” in the table above means the reading of emissions are attenuated more than 20dB below the permissible limits or the field strength is too small to be measured.

Radiated Spurious Emission Measurement Result (above 1GHz)

Operation Mode	TX MODE	Test Date	2020/04/07
Channel Number	CH Mid	Test By	Barry
Temperature	25	Humidity	60 %

No	Freq MHz	Reading dBuV	Factor dB	Level dBuV/m	Limit dBuV/m	Margin dB	Remark	Pol V/H
1	2442.00	55.99	-15.70	40.29	68.20	-27.91	Peak	VERTICAL
2	4073.00	46.41	-11.69	34.72	74.00	-39.28	Peak	VERTICAL
3	10520.00	38.40	4.63	43.03	68.20	-25.17	Peak	VERTICAL
4	15780.00	38.97	7.15	46.12	74.00	-27.88	Peak	VERTICAL
1	1707.00	50.46	-19.07	31.39	74.00	-42.61	Peak	HORIZONTAL
2	3597.00	46.99	-13.25	33.74	68.20	-34.46	Peak	HORIZONTAL
3	10520.00	37.00	4.63	41.63	68.20	-26.57	Peak	HORIZONTAL
4	15780.00	36.93	7.15	44.08	74.00	-29.92	Peak	HORIZONTAL

Remark:

- 1 Field strength limits for frequency above 1000MHz are based on average limits. However, Peak mode field strength shall not exceed the average limits specified plus 20dB.
- 2 Measurement of data within this frequency range shown “ - ” in the table above means the reading of emissions are attenuated more than 20dB below the permissible limits or the field strength is too small to be measured.

Radiated Spurious Emission Measurement Result (above 1GHz)

Operation Mode	TX MODE	Test Date	2020/04/07
Channel Number	CH High	Test By	Barry
Temperature	25	Humidity	60 %

No	Freq MHz	Reading dBuV	Factor dB	Level dBuV/m	Limit dBuV/m	Margin dB	Remark	Pol V/H
1	2267.00	48.50	-15.61	32.89	74.00	-41.11	Peak	VERTICAL
2	4276.00	47.63	-11.06	36.57	74.00	-37.43	Peak	VERTICAL
3	10640.00	36.64	5.01	41.65	74.00	-32.35	Peak	VERTICAL
4	15960.00	36.52	6.56	43.08	74.00	-30.92	Peak	VERTICAL
1	3660.00	48.46	-13.11	35.35	74.00	-38.65	Peak	HORIZONTAL
2	4808.00	48.30	-9.22	39.08	74.00	-34.92	Peak	HORIZONTAL
3	10640.00	34.65	5.01	39.66	74.00	-34.34	Peak	HORIZONTAL
4	15960.00	33.02	6.56	39.58	74.00	-34.42	Peak	HORIZONTAL

Remark:

- 1 Field strength limits for frequency above 1000MHz are based on average limits. However, Peak mode field strength shall not exceed the average limits specified plus 20dB.
- 2 Measurement of data within this frequency range shown “ - ” in the table above means the reading of emissions are attenuated more than 20dB below the permissible limits or the field strength is too small to be measured.

Radiated Spurious Emission Measurement Result (above 1GHz)

(Band UNII-1 / Band UNII-2A, 802.11n HT40 mode)

Operation Mode	TX MODE	Test Date	2020/04/07
Channel Number	CH Low	Test By	Barry
Temperature	25	Humidity	60 %

No	Freq MHz	Reading dBuV	Factor dB	Level dBuV/m	Limit dBuV/m	Margin dB	Remark	Pol V/H
1	3576.00	48.14	-13.34	34.80	68.20	-33.40	Peak	VERTICAL
2	4850.00	46.33	-9.11	37.22	74.00	-36.78	Peak	VERTICAL
3	10380.00	35.44	4.25	39.69	68.20	-28.51	Peak	VERTICAL
4	15570.00	34.82	7.85	42.67	74.00	-31.33	Peak	VERTICAL
1	3114.00	48.54	-14.28	34.26	68.20	-33.94	Peak	HORIZONTAL
2	4108.00	47.18	-11.57	35.61	74.00	-38.39	Peak	HORIZONTAL
3	10380.00	35.60	4.25	39.85	68.20	-28.35	Peak	HORIZONTAL
4	15570.00	34.79	7.85	42.64	74.00	-31.36	Peak	HORIZONTAL

Remark:

- 1 Field strength limits for frequency above 1000MHz are based on average limits. However, Peak mode field strength shall not exceed the average limits specified plus 20dB.
- 2 Measurement of data within this frequency range shown “ - ” in the table above means the reading of emissions are attenuated more than 20dB below the permissible limits or the field strength is too small to be measured.

Radiated Spurious Emission Measurement Result (above 1GHz)

Operation Mode	TX MODE	Test Date	2020/04/07
Channel Number	CH Mid	Test By	Barry
Temperature	25	Humidity	60 %

No	Freq MHz	Reading dBuV	Factor dB	Level dBuV/m	Limit dBuV/m	Margin dB	Remark	Pol V/H
1	2498.00	48.35	-15.69	32.66	74.00	-41.34	Peak	VERTICAL
2	4395.00	46.68	-10.64	36.04	74.00	-37.96	Peak	VERTICAL
3	10540.00	35.60	4.70	40.30	68.20	-27.90	Peak	VERTICAL
4	15810.00	36.20	7.04	43.24	74.00	-30.76	Peak	VERTICAL
1	2736.00	48.10	-15.14	32.96	74.00	-41.04	Peak	HORIZONTAL
2	3653.00	48.25	-13.12	35.13	74.00	-38.87	Peak	HORIZONTAL
3	10540.00	36.95	4.70	41.65	68.20	-26.55	Peak	HORIZONTAL
4	15810.00	38.80	7.04	45.84	74.00	-28.16	Peak	HORIZONTAL

Remark:

- 1 Field strength limits for frequency above 1000MHz are based on average limits. However, Peak mode field strength shall not exceed the average limits specified plus 20dB.
- 2 Measurement of data within this frequency range shown “ - ” in the table above means the reading of emissions are attenuated more than 20dB below the permissible limits or the field strength is too small to be measured.

Radiated Spurious Emission Measurement Result (above 1GHz)

Operation Mode	TX MODE	Test Date	2020/04/07
Channel Number	CH High	Test By	Barry
Temperature	25	Humidity	60 %

No	Freq MHz	Reading dBuV	Factor dB	Level dBuV/m	Limit dBuV/m	Margin dB	Remark	Pol V/H
1	3002.00	47.55	-14.56	32.99	68.20	-35.21	Peak	VERTICAL
2	4269.00	46.66	-11.08	35.58	74.00	-38.42	Peak	VERTICAL
3	10620.00	34.75	4.95	39.70	74.00	-34.30	Peak	VERTICAL
4	15930.00	36.41	6.65	43.06	74.00	-30.94	Peak	VERTICAL
1	2498.00	48.30	-15.69	32.61	74.00	-41.39	Peak	HORIZONTAL
2	4108.00	47.08	-11.57	35.51	74.00	-38.49	Peak	HORIZONTAL
3	10620.00	34.02	4.95	38.97	74.00	-35.03	Peak	HORIZONTAL
4	15930.00	34.91	6.65	41.56	74.00	-32.44	Peak	HORIZONTAL

Remark:

- 1 Field strength limits for frequency above 1000MHz are based on average limits. However, Peak mode field strength shall not exceed the average limits specified plus 20dB.
- 2 Measurement of data within this frequency range shown “ - ” in the table above means the reading of emissions are attenuated more than 20dB below the permissible limits or the field strength is too small to be measured.

Radiated Spurious Emission Measurement Result (above 1GHz)
(Band UNII-1 / Band UNII-2A, 802.11ac VHT80 mode)

Operation Mode	TX MODE	Test Date	2020/04/07
Channel Number	CH Low	Test By	Barry
Temperature	25	Humidity	60 %

No	Freq MHz	Reading dBuV	Factor dB	Level dBuV/m	Limit dBuV/m	Margin dB	Remark	Pol V/H
1	2869.00	47.79	-14.94	32.85	74.00	-41.15	Peak	VERTICAL
2	4437.00	46.39	-10.49	35.90	68.20	-32.30	Peak	VERTICAL
3	10420.00	35.43	4.36	39.79	68.20	-28.41	Peak	VERTICAL
4	15630.00	34.37	7.65	42.02	74.00	-31.98	Peak	VERTICAL
1	3464.00	48.34	-13.91	34.43	68.20	-33.77	Peak	HORIZONTAL
2	4087.00	47.47	-11.63	35.84	74.00	-38.16	Peak	HORIZONTAL
3	10420.00	35.91	4.36	40.27	68.20	-27.93	Peak	HORIZONTAL
4	15630.00	34.57	7.65	42.22	74.00	-31.78	Peak	HORIZONTAL

Remark:

- 1 Field strength limits for frequency above 1000MHz are based on average limits. However, Peak mode field strength shall not exceed the average limits specified plus 20dB.
- 2 Measurement of data within this frequency range shown “ - ” in the table above means the reading of emissions are attenuated more than 20dB below the permissible limits or the field strength is too small to be measured.

Radiated Spurious Emission Measurement Result (above 1GHz)

Operation Mode	TX MODE	Test Date	2020/04/07
Channel Number	CH High	Test By	Barry
Temperature	25	Humidity	60 %

No	Freq MHz	Reading dBuV	Factor dB	Level dBuV/m	Limit dBuV/m	Margin dB	Remark	Pol V/H
1	1210.00	56.38	-19.78	36.60	74.00	-37.40	Peak	VERTICAL
2	4129.00	47.18	-11.52	35.66	74.00	-38.34	Peak	VERTICAL
3	10580.00	39.59	4.82	44.41	68.20	-23.79	Peak	VERTICAL
4	15780.00	36.55	7.15	43.70	74.00	-30.30	Peak	VERTICAL
1	2547.00	48.82	-15.56	33.26	68.20	-34.94	Peak	HORIZONTAL
2	4178.00	48.85	-11.36	37.49	74.00	-36.51	Peak	HORIZONTAL
3	10580.00	36.89	4.82	41.71	68.20	-26.49	Peak	HORIZONTAL
4	15780.00	37.90	7.15	45.05	74.00	-28.95	Peak	HORIZONTAL

Remark:

- 1 Field strength limits for frequency above 1000MHz are based on average limits. However, Peak mode field strength shall not exceed the average limits specified plus 20dB.
- 2 Measurement of data within this frequency range shown “ - ” in the table above means the reading of emissions are attenuated more than 20dB below the permissible limits or the field strength is too small to be measured.

Radiated Spurious Emission Measurement Result (above 1GHz)

(Band UNII-2C, 802.11a mode)

Operation Mode	TX MODE	Test Date	2020/04/07
Channel Number	CH Low	Test By	Barry
Temperature	25	Humidity	60 %

No	Freq MHz	Reading dBuV	Factor dB	Level dBuV/m	Limit dBuV/m	Margin dB	Remark	Pol V/H
1	1210.00	54.99	-19.78	35.21	74.00	-38.79	Peak	VERTICAL
2	4829.00	58.30	-9.16	49.14	74.00	-24.86	Peak	VERTICAL
3	11000.00	35.23	6.12	41.35	74.00	-32.65	Peak	VERTICAL
4	16500.00	36.56	7.71	44.27	68.20	-23.93	Peak	VERTICAL
1	2855.00	48.47	-14.96	33.51	74.00	-40.49	Peak	HORIZONTAL
2	3548.00	49.58	-13.46	36.12	68.20	-32.08	Peak	HORIZONTAL
3	11000.00	35.35	6.12	41.47	74.00	-32.53	Peak	HORIZONTAL
4	16500.00	37.65	7.71	45.36	68.20	-22.84	Peak	HORIZONTAL

Remark:

- 1 Field strength limits for frequency above 1000MHz are based on average limits. However, Peak mode field strength shall not exceed the average limits specified plus 20dB.
- 2 Measurement of data within this frequency range shown “ - ” in the table above means the reading of emissions are attenuated more than 20dB below the permissible limits or the field strength is too small to be measured.

Radiated Spurious Emission Measurement Result (above 1GHz)

Operation Mode	TX MODE	Test Date	2020/04/07
Channel Number	CH Mid	Test By	Barry
Temperature	25	Humidity	60 %

No	Freq MHz	Reading dBuV	Factor dB	Level dBuV/m	Limit dBuV/m	Margin dB	Remark	Pol V/H
1	3065.00	48.84	-14.37	34.47	68.20	-33.73	Peak	VERTICAL
2	4444.00	47.64	-10.45	37.19	68.20	-31.01	Peak	VERTICAL
3	11200.00	35.92	6.28	42.20	74.00	-31.80	Peak	VERTICAL
4	16800.00	37.11	8.72	45.83	68.20	-22.37	Peak	VERTICAL
1	3646.00	49.62	-13.14	36.48	74.00	-37.52	Peak	HORIZONTAL
2	4682.00	46.79	-9.59	37.20	74.00	-36.80	Peak	HORIZONTAL
3	11200.00	35.80	6.28	42.08	74.00	-31.92	Peak	HORIZONTAL
4	16800.00	37.40	8.72	46.12	68.20	-22.08	Peak	HORIZONTAL

Remark:

- 1 Field strength limits for frequency above 1000MHz are based on average limits. However, Peak mode field strength shall not exceed the average limits specified plus 20dB.
- 2 Measurement of data within this frequency range shown “ - ” in the table above means the reading of emissions are attenuated more than 20dB below the permissible limits or the field strength is too small to be measured.

Radiated Spurious Emission Measurement Result (above 1GHz)

Operation Mode	TX MODE	Test Date	2020/04/07
Channel Number	CH High	Test By	Barry
Temperature	25	Humidity	60 %

No	Freq MHz	Reading dBuV	Factor dB	Level dBuV/m	Limit dBuV/m	Margin dB	Remark	Pol V/H
1	2638.00	48.25	-15.33	32.92	68.20	-35.28	Peak	VERTICAL
2	3681.00	48.64	-13.06	35.58	74.00	-38.42	Peak	VERTICAL
3	11400.00	34.12	6.44	40.56	74.00	-33.44	Peak	VERTICAL
4	17100.00	34.76	10.29	45.05	68.20	-23.15	Peak	VERTICAL
1	2960.00	48.49	-14.69	33.80	68.20	-34.40	Peak	HORIZONTAL
2	4150.00	46.29	-11.44	34.85	74.00	-39.15	Peak	HORIZONTAL
3	11400.00	36.69	6.44	43.13	74.00	-30.87	Peak	HORIZONTAL
4	17100.00	35.01	10.29	45.30	68.20	-22.90	Peak	HORIZONTAL

Remark:

- 1 Field strength limits for frequency above 1000MHz are based on average limits. However, Peak mode field strength shall not exceed the average limits specified plus 20dB.
- 2 Measurement of data within this frequency range shown “ - ” in the table above means the reading of emissions are attenuated more than 20dB below the permissible limits or the field strength is too small to be measured.

**Radiated Spurious Emission Measurement Result (above 1GHz)
(Band UNII-2C, 802.11n HT40 mode)**

Operation Mode	TX MODE	Test Date	2020/04/07
Channel Number	CH Low	Test By	Barry
Temperature	25	Humidity	60 %

No	Freq MHz	Reading dBuV	Factor dB	Level dBuV/m	Limit dBuV/m	Margin dB	Remark	Pol V/H
1	1210.00	53.83	-19.78	34.05	74.00	-39.95	Peak	VERTICAL
2	1707.00	51.92	-19.07	32.85	74.00	-41.15	Peak	VERTICAL
3	11020.00	35.01	6.13	41.14	74.00	-32.86	Peak	VERTICAL
4	16530.00	36.06	7.82	43.88	68.20	-24.32	Peak	VERTICAL
1	2414.00	47.97	-15.71	32.26	68.20	-35.94	Peak	HORIZONTAL
2	4143.00	48.20	-11.47	36.73	74.00	-37.27	Peak	HORIZONTAL
3	11020.00	35.15	6.13	41.28	74.00	-32.72	Peak	HORIZONTAL
4	16530.00	38.41	7.82	46.23	68.20	-21.97	Peak	HORIZONTAL

Remark:

- 1 Field strength limits for frequency above 1000MHz are based on average limits. However, Peak mode field strength shall not exceed the average limits specified plus 20dB.
- 2 Measurement of data within this frequency range shown “ - ” in the table above means the reading of emissions are attenuated more than 20dB below the permissible limits or the field strength is too small to be measured.

Radiated Spurious Emission Measurement Result (above 1GHz)

Operation Mode	TX MODE	Test Date	2020/04/07
Channel Number	CH Mid	Test By	Barry
Temperature	25	Humidity	60 %

No	Freq MHz	Reading dBuV	Factor dB	Level dBuV/m	Limit dBuV/m	Margin dB	Remark	Pol V/H
1	1210.00	51.92	-19.78	32.14	74.00	-41.86	Peak	VERTICAL
2	2855.00	49.08	-14.96	34.12	74.00	-39.88	Peak	VERTICAL
3	11180.00	37.60	6.27	43.87	74.00	-30.13	Peak	VERTICAL
4	16770.00	36.72	8.62	45.34	68.20	-22.86	Peak	VERTICAL
1	2498.00	48.22	-15.69	32.53	74.00	-41.47	Peak	HORIZONTAL
2	4108.00	48.02	-11.57	36.45	74.00	-37.55	Peak	HORIZONTAL
3	11180.00	36.71	6.27	42.98	74.00	-31.02	Peak	HORIZONTAL
4	16770.00	35.97	8.62	44.59	68.20	-23.61	Peak	HORIZONTAL

Remark:

- 1 Field strength limits for frequency above 1000MHz are based on average limits. However, Peak mode field strength shall not exceed the average limits specified plus 20dB.
- 2 Measurement of data within this frequency range shown “ - ” in the table above means the reading of emissions are attenuated more than 20dB below the permissible limits or the field strength is too small to be measured.

Radiated Spurious Emission Measurement Result (above 1GHz)

Operation Mode	TX MODE	Test Date	2020/04/07
Channel Number	CH High	Test By	Barry
Temperature	25	Humidity	60 %

No	Freq MHz	Reading dBuV	Factor dB	Level dBuV/m	Limit dBuV/m	Margin dB	Remark	Pol V/H
1	2547.00	48.46	-15.56	32.90	68.20	-35.30	Peak	VERTICAL
2	3639.00	48.08	-13.15	34.93	74.00	-39.07	Peak	VERTICAL
3	11340.00	34.14	6.39	40.53	74.00	-33.47	Peak	VERTICAL
4	17010.00	36.26	9.49	45.75	68.20	-22.45	Peak	VERTICAL
1	2876.00	48.46	-14.92	33.54	74.00	-40.46	Peak	HORIZONTAL
2	4101.00	47.39	-11.59	35.80	74.00	-38.20	Peak	HORIZONTAL
3	11340.00	37.15	6.39	43.54	74.00	-30.46	Peak	HORIZONTAL
4	17010.00	35.55	9.49	45.04	68.20	-23.16	Peak	HORIZONTAL

Remark:

- 1 Field strength limits for frequency above 1000MHz are based on average limits. However, Peak mode field strength shall not exceed the average limits specified plus 20dB.
- 2 Measurement of data within this frequency range shown “ - ” in the table above means the reading of emissions are attenuated more than 20dB below the permissible limits or the field strength is too small to be measured.

**Radiated Spurious Emission Measurement Result (above 1GHz)
(Band UNII-2C, 802.11ac VHT80 mode)**

Operation Mode	TX MODE	Test Date	2020/04/07
Channel Number	CH Low	Test By	Barry
Temperature	25	Humidity	60 %

No	Freq MHz	Reading dBuV	Factor dB	Level dBuV/m	Limit dBuV/m	Margin dB	Remark	Pol V/H
1	2162.00	47.76	-15.93	31.83	68.20	-36.37	Peak	VERTICAL
2	3205.00	48.51	-14.33	34.18	68.20	-34.02	Peak	VERTICAL
3	11060.00	32.38	6.17	38.55	74.00	-35.45	Peak	VERTICAL
4	16590.00	35.34	8.02	43.36	68.20	-24.84	Peak	VERTICAL
1	2267.00	48.20	-15.61	32.59	74.00	-41.41	Peak	HORIZONTAL
2	4066.00	47.16	-11.70	35.46	74.00	-38.54	Peak	HORIZONTAL
3	11060.00	34.51	6.17	40.68	74.00	-33.32	Peak	HORIZONTAL
4	16590.00	35.49	8.02	43.51	68.20	-24.69	Peak	HORIZONTAL

Remark:

- 1 Field strength limits for frequency above 1000MHz are based on average limits. However, Peak mode field strength shall not exceed the average limits specified plus 20dB.
- 2 Measurement of data within this frequency range shown “ - ” in the table above means the reading of emissions are attenuated more than 20dB below the permissible limits or the field strength is too small to be measured.

Radiated Spurious Emission Measurement Result (above 1GHz)

Operation Mode	TX MODE	Test Date	2020/04/07
Channel Number	CH High	Test By	Barry
Temperature	25	Humidity	60 %

No	Freq MHz	Reading dBuV	Factor dB	Level dBuV/m	Limit dBuV/m	Margin dB	Remark	Pol V/H
1	1707.00	51.66	-19.07	32.59	74.00	-41.41	Peak	VERTICAL
2	4402.00	46.14	-10.63	35.51	68.20	-32.69	Peak	VERTICAL
3	11220.00	35.15	6.29	41.44	74.00	-32.56	Peak	VERTICAL
4	16830.00	36.87	8.83	45.70	68.20	-22.50	Peak	VERTICAL
1	2484.00	48.04	-15.69	32.35	74.00	-41.65	Peak	HORIZONTAL
2	4080.00	46.21	-11.66	34.55	74.00	-39.45	Peak	HORIZONTAL
3	11220.00	35.39	6.29	41.68	74.00	-32.32	Peak	HORIZONTAL
4	16830.00	38.57	8.83	47.40	68.20	-20.80	Peak	HORIZONTAL

Remark:

- 1 Field strength limits for frequency above 1000MHz are based on average limits. However, Peak mode field strength shall not exceed the average limits specified plus 20dB.
- 2 Measurement of data within this frequency range shown “ - ” in the table above means the reading of emissions are attenuated more than 20dB below the permissible limits or the field strength is too small to be measured.

Radiated Spurious Emission Measurement Result (above 1GHz)
(Band UNII-3, 802.11a mode)

Operation Mode	TX MODE	Test Date	2020/04/07
Channel Number	CH Low	Test By	Barry
Temperature	25	Humidity	60 %

No	Freq MHz	Reading dBuV	Factor dB	Level dBuV/m	Limit dBuV/m	Margin dB	Remark	Pol V/H
1	1210.00	52.48	-19.78	32.70	74.00	-41.30	Peak	VERTICAL
2	2267.00	48.21	-15.61	32.60	74.00	-41.40	Peak	VERTICAL
3	11490.00	35.70	6.52	42.22	74.00	-31.78	Peak	VERTICAL
4	17235.00	35.92	11.50	47.42	68.20	-20.78	Peak	VERTICAL
1	3646.00	49.62	-13.14	36.48	74.00	-37.52	Peak	HORIZONTAL
2	4682.00	46.79	-9.59	37.20	74.00	-36.80	Peak	HORIZONTAL
3	11490.00	35.82	6.52	42.34	74.00	-31.66	Peak	HORIZONTAL
4	17235.00	33.46	11.50	44.96	68.20	-23.24	Peak	HORIZONTAL

Remark:

- 1 Field strength limits for frequency above 1000MHz are based on average limits. However, Peak mode field strength shall not exceed the average limits specified plus 20dB.
- 2 Measurement of data within this frequency range shown “ - ” in the table above means the reading of emissions are attenuated more than 20dB below the permissible limits or the field strength is too small to be measured.

Radiated Spurious Emission Measurement Result (above 1GHz)

Operation Mode	TX MODE	Test Date	2020/04/07
Channel Number	CH Mid	Test By	Barry
Temperature	25	Humidity	60 %

No	Freq MHz	Reading dBuV	Factor dB	Level dBuV/m	Limit dBuV/m	Margin dB	Remark	Pol V/H
1	4129.00	47.75	-11.52	36.23	74.00	-37.77	Peak	VERTICAL
2	4451.00	46.73	-10.44	36.29	68.20	-31.91	Peak	VERTICAL
3	11570.00	34.48	6.54	41.02	74.00	-32.98	Peak	VERTICAL
4	17355.00	33.45	12.56	46.01	68.20	-22.19	Peak	VERTICAL
1	2946.00	48.36	-14.72	33.64	68.20	-34.56	Peak	HORIZONTAL
2	4101.00	48.90	-11.59	37.31	74.00	-36.69	Peak	HORIZONTAL
3	11570.00	33.79	6.54	40.33	74.00	-33.67	Peak	HORIZONTAL
4	17355.00	34.33	12.56	46.89	68.20	-21.31	Peak	HORIZONTAL

Remark:

- 1 Field strength limits for frequency above 1000MHz are based on average limits. However, Peak mode field strength shall not exceed the average limits specified plus 20dB.
- 2 Measurement of data within this frequency range shown “ - ” in the table above means the reading of emissions are attenuated more than 20dB below the permissible limits or the field strength is too small to be measured.

Radiated Spurious Emission Measurement Result (above 1GHz)

Operation Mode	TX MODE	Test Date	2020/04/07
Channel Number	CH High	Test By	Barry
Temperature	25	Humidity	60 %

No	Freq MHz	Reading dBuV	Factor dB	Level dBuV/m	Limit dBuV/m	Margin dB	Remark	Pol V/H
1	1210.00	53.01	-19.78	33.23	74.00	-40.77	Peak	VERTICAL
2	3555.00	48.63	-13.42	35.21	68.20	-32.99	Peak	VERTICAL
3	11650.00	34.50	6.56	41.06	74.00	-32.94	Peak	VERTICAL
4	17475.00	33.31	13.64	46.95	68.20	-21.25	Peak	VERTICAL
1	2505.00	48.53	-15.67	32.86	68.20	-35.34	Peak	HORIZONTAL
2	4073.00	45.96	-11.69	34.27	74.00	-39.73	Peak	HORIZONTAL
3	11650.00	35.84	6.56	42.40	74.00	-31.60	Peak	HORIZONTAL
4	17475.00	32.45	13.64	46.09	68.20	-22.11	Peak	HORIZONTAL

Remark:

- 1 Field strength limits for frequency above 1000MHz are based on average limits. However, Peak mode field strength shall not exceed the average limits specified plus 20dB.
- 2 Measurement of data within this frequency range shown “ - ” in the table above means the reading of emissions are attenuated more than 20dB below the permissible limits or the field strength is too small to be measured.

Radiated Spurious Emission Measurement Result (above 1GHz)
(Band UNII-3, 802.11n HT40 mode)

Operation Mode	TX MODE	Test Date	2020/04/07
Channel Number	CH Low	Test By	Barry
Temperature	25	Humidity	60 %

No	Freq MHz	Reading dBuV	Factor dB	Level dBuV/m	Limit dBuV/m	Margin dB	Remark	Pol V/H
1	2288.00	48.32	-15.61	32.71	74.00	-41.29	Peak	VERTICAL
2	4066.00	46.58	-11.70	34.88	74.00	-39.12	Peak	VERTICAL
3	11510.00	35.66	6.53	42.19	74.00	-31.81	Peak	VERTICAL
4	17265.00	33.69	11.76	45.45	68.20	-22.75	Peak	VERTICAL
1	2281.00	47.85	-15.60	32.25	74.00	-41.75	Peak	HORIZONTAL
2	4171.00	47.32	-11.38	35.94	74.00	-38.06	Peak	HORIZONTAL
3	11510.00	35.86	6.53	42.39	74.00	-31.61	Peak	HORIZONTAL
4	17265.00	35.63	11.76	47.39	68.20	-20.81	Peak	HORIZONTAL

Remark:

- 1 Field strength limits for frequency above 1000MHz are based on average limits. However, Peak mode field strength shall not exceed the average limits specified plus 20dB.
- 2 Measurement of data within this frequency range shown “ - ” in the table above means the reading of emissions are attenuated more than 20dB below the permissible limits or the field strength is too small to be measured.

Radiated Spurious Emission Measurement Result (above 1GHz)

Operation Mode	TX MODE	Test Date	2020/04/07
Channel Number	CH High	Test By	Barry
Temperature	25	Humidity	60 %

No	Freq MHz	Reading dBuV	Factor dB	Level dBuV/m	Limit dBuV/m	Margin dB	Remark	Pol V/H
1	2407.00	48.07	-15.71	32.36	68.20	-35.84	Peak	VERTICAL
2	4101.00	47.48	-11.59	35.89	74.00	-38.11	Peak	VERTICAL
3	11590.00	34.74	6.55	41.29	74.00	-32.71	Peak	VERTICAL
4	17385.00	32.69	12.83	45.52	68.20	-22.68	Peak	VERTICAL
1	2281.00	48.34	-15.60	32.74	74.00	-41.26	Peak	HORIZONTAL
2	4276.00	46.04	-11.06	34.98	74.00	-39.02	Peak	HORIZONTAL
3	11590.00	36.79	6.55	43.34	74.00	-30.66	Peak	HORIZONTAL
4	17385.00	35.27	12.83	48.10	68.20	-20.10	Peak	HORIZONTAL

Remark:

- 1 Field strength limits for frequency above 1000MHz are based on average limits. However, Peak mode field strength shall not exceed the average limits specified plus 20dB.
- 2 Measurement of data within this frequency range shown “ - ” in the table above means the reading of emissions are attenuated more than 20dB below the permissible limits or the field strength is too small to be measured.

Radiated Spurious Emission Measurement Result (above 1GHz)
(Band UNII-3, 802.11ac VHT80 mode)

Operation Mode	TX MODE	Test Date	2020/04/07
Channel Number	CH Low	Test By	Barry
Temperature	25	Humidity	60 %

No	Freq MHz	Reading dBuV	Factor dB	Level dBuV/m	Limit dBuV/m	Margin dB	Remark	Pol V/H
1	1203.00	55.14	-19.83	35.31	74.00	-38.69	Peak	VERTICAL
2	4066.00	46.64	-11.70	34.94	74.00	-39.06	Peak	VERTICAL
3	11550.00	34.64	6.53	41.17	74.00	-32.83	Peak	VERTICAL
4	17325.00	33.40	12.30	45.70	68.20	-22.50	Peak	VERTICAL
1	3002.00	48.64	-14.56	34.08	68.20	-34.12	Peak	HORIZONTAL
2	4171.00	47.48	-11.38	36.10	74.00	-37.90	Peak	HORIZONTAL
3	11550.00	32.68	6.53	39.21	74.00	-34.79	Peak	HORIZONTAL
4	17325.00	32.15	12.30	44.45	68.20	-23.75	Peak	HORIZONTAL

Remark:

- 1 Field strength limits for frequency above 1000MHz are based on average limits. However, Peak mode field strength shall not exceed the average limits specified plus 20dB.
- 2 Measurement of data within this frequency range shown “ - ” in the table above means the reading of emissions are attenuated more than 20dB below the permissible limits or the field strength is too small to be measured.

PIFA Ant

Radiated Spurious Emission Measurement Result (below 1GHz)

(Band UNII-1 / Band UNII-2A, 802.11a mode)

Operation Mode	TX MODE	Test Date	2020/01/21
Channel Number	CH Low	Test By	Barry
Temperature	25	Pol	Ver./Hor
Humidity	65 %		

No	Freq MHz	Reading dBuV	Factor dB	Level dBuV/m	Limit dBuV/m	Margin dB	Remark	Pol V/H
1	71.71	44.28	-8.21	36.07	40.00	-3.93	Peak	VERTICAL
2	395.69	41.82	-2.08	39.74	46.00	-6.26	Peak	VERTICAL
3	500.45	37.14	-0.64	36.50	46.00	-9.50	Peak	VERTICAL
4	625.58	38.34	1.77	40.11	46.00	-5.89	Peak	VERTICAL
5	750.71	38.57	3.99	42.56	46.00	-3.44	Peak	VERTICAL
6	875.84	31.82	5.71	37.53	46.00	-8.47	Peak	VERTICAL
1	500.45	43.03	-0.64	42.39	46.00	-3.61	Peak	HORIZONTAL
2	514.03	33.85	-0.18	33.67	46.00	-12.33	Peak	HORIZONTAL
3	625.58	39.73	1.77	41.50	46.00	-4.50	Peak	HORIZONTAL
4	750.71	28.88	3.99	32.87	46.00	-13.13	Peak	HORIZONTAL
5	824.43	26.56	5.05	31.61	46.00	-14.39	Peak	HORIZONTAL
6	875.84	31.73	5.71	37.44	46.00	-8.56	Peak	HORIZONTAL

Remark:

- 1 The measured emissions between 9kHz to 30MHz are 20dB lower against the limit, so the result is not recorded in the report.
- 2 Measuring frequencies from the lowest internal frequency to the 1GHz.
- 3 Radiated emissions measured in frequency range from 9kHz to 1000MHz were made with an instrument detector setting 9-90kHz/110-490kHz using PK/AV and other Frequency Band using PK/QP
- 4 Measurement result within this frequency range shown “ - ” in the table above means the reading of emissions are attenuated more than 20dB below the permissible limits or the field strength is too small to be measured.

Radiated Spurious Emission Measurement Result (below 1GHz)

Operation Mode	TX MODE	Test Date	2020/01/21
Channel Number	CH Mid	Test By	Barry
Temperature	25	Pol	Ver./Hor
Humidity	65 %		

No	Freq MHz	Reading dBuV	Factor dB	Level dBuV/m	Limit dBuV/m	Margin dB	Remark	Pol V/H
1	71.71	41.86	-8.21	33.65	40.00	-6.35	Peak	VERTICAL
2	83.35	42.04	-10.82	31.22	40.00	-8.78	Peak	VERTICAL
3	395.69	35.31	-2.08	33.23	46.00	-12.77	Peak	VERTICAL
4	497.54	32.96	-0.67	32.29	46.00	-13.71	Peak	VERTICAL
5	625.58	31.16	1.77	32.93	46.00	-13.07	Peak	VERTICAL
6	750.71	29.67	3.99	33.66	46.00	-12.34	Peak	VERTICAL
1	500.45	38.82	-0.64	38.18	46.00	-7.82	Peak	HORIZONTAL
2	592.60	27.67	1.37	29.04	46.00	-16.96	Peak	HORIZONTAL
3	680.87	27.33	2.62	29.95	46.00	-16.05	Peak	HORIZONTAL
4	750.71	30.50	3.99	34.49	46.00	-11.51	Peak	HORIZONTAL
5	875.84	27.89	5.71	33.60	46.00	-12.40	Peak	HORIZONTAL
6	952.47	27.72	7.02	34.74	46.00	-11.26	Peak	HORIZONTAL

Remark:

- 1 The measured emissions between 9kHz to 30MHz are 20dB lower against the limit, so the result is not recorded in the report.
- 2 Measuring frequencies from the lowest internal frequency to the 1GHz.
- 3 Radiated emissions measured in frequency range from 9kHz to 1000MHz were made with an instrument detector setting 9-90kHz/110-490kHz using PK/AV and other Frequency Band using PK/QP
- 4 Measurement result within this frequency range shown “ - ” in the table above means the reading of emissions are attenuated more than 20dB below the permissible limits or the field strength is too small to be measured.

Radiated Spurious Emission Measurement Result (below 1GHz)

Operation Mode	TX MODE	Test Date	2020/01/21
Channel Number	CH High	Test By	Barry
Temperature	25	Pol	Ver./Hor
Humidity	65 %		

No	Freq MHz	Reading dBuV	Factor dB	Level dBuV/m	Limit dBuV/m	Margin dB	Remark	Pol V/H
1	77.53	40.09	-9.43	30.66	40.00	-9.34	Peak	VERTICAL
2	395.69	37.90	-2.08	35.82	46.00	-10.18	Peak	VERTICAL
3	500.45	38.75	-0.64	38.11	46.00	-7.89	Peak	VERTICAL
4	625.58	39.68	1.77	41.45	46.00	-4.55	Peak	VERTICAL
5	750.71	37.78	3.99	41.77	46.00	-4.23	Peak	VERTICAL
6	875.84	30.49	5.71	36.20	46.00	-9.80	Peak	VERTICAL
1	250.19	35.41	-5.51	29.90	46.00	-16.10	Peak	HORIZONTAL
2	375.32	35.47	-2.39	33.08	46.00	-12.92	Peak	HORIZONTAL
3	500.45	40.05	-0.64	39.41	46.00	-6.59	Peak	HORIZONTAL
4	515.00	35.67	-0.14	35.53	46.00	-10.47	Peak	HORIZONTAL
5	520.82	33.88	0.08	33.96	46.00	-12.04	Peak	HORIZONTAL
6	625.58	33.84	1.77	35.61	46.00	-10.39	Peak	HORIZONTAL

Remark:

- 1 The measured emissions between 9kHz to 30MHz are 20dB lower against the limit, so the result is not recorded in the report.
- 2 Measuring frequencies from the lowest internal frequency to the 1GHz.
- 3 Radiated emissions measured in frequency range from 9kHz to 1000MHz were made with an instrument detector setting 9-90kHz/110-490kHz using PK/AV and other Frequency Band using PK/QP
- 4 Measurement result within this frequency range shown “ - ” in the table above means the reading of emissions are attenuated more than 20dB below the permissible limits or the field strength is too small to be measured.

**Radiated Spurious Emission Measurement Result (below 1GHz)
(Band UNII-1 / Band UNII-2A, 802.11n HT40 mode)**

Operation Mode	TX MODE	Test Date	2020/01/21
Channel Number	CH Low	Test By	Barry
Temperature	25	Pol	Ver./Hor
Humidity	65 %		

No	Freq MHz	Reading dBuV	Factor dB	Level dBuV/m	Limit dBuV/m	Margin dB	Remark	Pol V/H
1	74.62	40.11	-8.80	31.31	40.00	-8.69	Peak	VERTICAL
2	375.32	34.01	-2.39	31.62	46.00	-14.38	Peak	VERTICAL
3	395.69	39.10	-2.08	37.02	46.00	-8.98	Peak	VERTICAL
4	500.45	40.28	-0.64	39.64	46.00	-6.36	Peak	VERTICAL
5	625.58	35.73	1.77	37.50	46.00	-8.50	Peak	VERTICAL
6	750.71	32.72	3.99	36.71	46.00	-9.29	Peak	VERTICAL
1	274.44	34.77	-4.60	30.17	46.00	-15.83	Peak	HORIZONTAL
2	375.32	35.00	-2.39	32.61	46.00	-13.39	Peak	HORIZONTAL
3	492.69	38.42	-0.70	37.72	46.00	-8.28	Peak	HORIZONTAL
4	500.45	36.64	-0.64	36.00	46.00	-10.00	Peak	HORIZONTAL
5	750.71	28.06	3.99	32.05	46.00	-13.95	Peak	HORIZONTAL
6	952.47	27.40	7.02	34.42	46.00	-11.58	Peak	HORIZONTAL

Remark:

- 1 The measured emissions between 9kHz to 30MHz are 20dB lower against the limit, so the result is not recorded in the report.
- 2 Measuring frequencies from the lowest internal frequency to the 1GHz.
- 3 Radiated emissions measured in frequency range from 9kHz to 1000MHz were made with an instrument detector setting 9-90kHz/110-490kHz using PK/AV and other Frequency Band using PK/QP
- 4 Measurement result within this frequency range shown “ - ” in the table above means the reading of emissions are attenuated more than 20dB below the permissible limits or the field strength is too small to be measured.

Radiated Spurious Emission Measurement Result (below 1GHz)

Operation Mode	TX MODE	Test Date	2020/01/21
Channel Number	CH Mid	Test By	Barry
Temperature	25	Pol	Ver./Hor
Humidity	65 %		

No	Freq MHz	Reading dBuV	Factor dB	Level dBuV/m	Limit dBuV/m	Margin dB	Remark	Pol V/H
1	71.71	43.27	-8.21	35.06	40.00	-4.94	Peak	VERTICAL
2	375.32	37.26	-2.39	34.87	46.00	-11.13	Peak	VERTICAL
3	493.66	36.57	-0.69	35.88	46.00	-10.12	Peak	VERTICAL
4	625.58	35.64	1.77	37.41	46.00	-8.59	Peak	VERTICAL
5	750.71	38.17	3.99	42.16	46.00	-3.84	Peak	VERTICAL
6	875.84	29.55	5.71	35.26	46.00	-10.74	Peak	VERTICAL
1	83.35	39.76	-10.82	28.94	40.00	-11.06	Peak	HORIZONTAL
2	375.32	33.46	-2.39	31.07	46.00	-14.93	Peak	HORIZONTAL
3	495.60	33.08	-0.68	32.40	46.00	-13.60	Peak	HORIZONTAL
4	625.58	28.30	1.77	30.07	46.00	-15.93	Peak	HORIZONTAL
5	750.71	28.04	3.99	32.03	46.00	-13.97	Peak	HORIZONTAL
6	952.47	28.57	7.02	35.59	46.00	-10.41	Peak	HORIZONTAL

Remark:

- 1 The measured emissions between 9kHz to 30MHz are 20dB lower against the limit, so the result is not recorded in the report.
- 2 Measuring frequencies from the lowest internal frequency to the 1GHz.
- 3 Radiated emissions measured in frequency range from 9kHz to 1000MHz were made with an instrument detector setting 9-90kHz/110-490kHz using PK/AV and other Frequency Band using PK/QP
- 4 Measurement result within this frequency range shown “ - ” in the table above means the reading of emissions are attenuated more than 20dB below the permissible limits or the field strength is too small to be measured.

Radiated Spurious Emission Measurement Result (below 1GHz)

Operation Mode	TX MODE	Test Date	2020/01/21
Channel Number	CH High	Test By	Barry
Temperature	25	Pol	Ver./Hor
Humidity	65 %		

No	Freq MHz	Reading dBuV	Factor dB	Level dBuV/m	Limit dBuV/m	Margin dB	Remark	Pol V/H
1	71.71	43.24	-8.21	35.03	40.00	-4.97	Peak	VERTICAL
2	395.69	35.89	-2.08	33.81	46.00	-12.19	Peak	VERTICAL
3	500.45	37.61	-0.64	36.97	46.00	-9.03	Peak	VERTICAL
4	518.88	36.67	0.02	36.69	46.00	-9.31	Peak	VERTICAL
5	750.71	32.43	3.99	36.42	46.00	-9.58	Peak	VERTICAL
6	875.84	28.78	5.71	34.49	46.00	-11.51	Peak	VERTICAL
1	71.71	39.99	-8.21	31.78	40.00	-8.22	Peak	HORIZONTAL
2	375.32	33.77	-2.39	31.38	46.00	-14.62	Peak	HORIZONTAL
3	495.60	32.75	-0.68	32.07	46.00	-13.93	Peak	HORIZONTAL
4	625.58	29.27	1.77	31.04	46.00	-14.96	Peak	HORIZONTAL
5	850.62	26.08	5.35	31.43	46.00	-14.57	Peak	HORIZONTAL
6	952.47	29.06	7.02	36.08	46.00	-9.92	Peak	HORIZONTAL

Remark:

- 1 The measured emissions between 9kHz to 30MHz are 20dB lower against the limit, so the result is not recorded in the report.
- 2 Measuring frequencies from the lowest internal frequency to the 1GHz.
- 3 Radiated emissions measured in frequency range from 9kHz to 1000MHz were made with an instrument detector setting 9-90kHz/110-490kHz using PK/AV and other Frequency Band using PK/QP
- 4 Measurement result within this frequency range shown “ - ” in the table above means the reading of emissions are attenuated more than 20dB below the permissible limits or the field strength is too small to be measured.

**Radiated Spurious Emission Measurement Result (below 1GHz)
(Band UNII-1 / Band UNII-2A, 802.11ac VHT80 mode)**

Operation Mode	TX MODE	Test Date	2020/01/21
Channel Number	CH Low	Test By	Barry
Temperature	25	Pol	Ver./Hor
Humidity	65 %		

No	Freq MHz	Reading dBuV	Factor dB	Level dBuV/m	Limit dBuV/m	Margin dB	Remark	Pol V/H
1	323.91	27.41	-3.33	24.08	46.00	-21.92	Peak	VERTICAL
2	377.26	28.46	-2.36	26.10	46.00	-19.90	Peak	VERTICAL
3	573.20	27.32	0.80	28.12	46.00	-17.88	Peak	VERTICAL
4	695.42	26.55	3.05	29.60	46.00	-16.40	Peak	VERTICAL
5	765.26	27.44	4.24	31.68	46.00	-14.32	Peak	VERTICAL
6	831.22	27.76	5.16	32.92	46.00	-13.08	Peak	VERTICAL
1	395.69	33.94	-2.08	31.86	46.00	-14.14	Peak	HORIZONTAL
2	500.45	43.26	-0.64	42.62	46.00	-3.38	Peak	HORIZONTAL
3	625.58	38.03	1.77	39.80	46.00	-6.20	Peak	HORIZONTAL
4	791.45	29.03	4.47	33.50	46.00	-12.50	Peak	HORIZONTAL
5	821.52	30.65	5.02	35.67	46.00	-10.33	Peak	HORIZONTAL
6	875.84	31.56	5.71	37.27	46.00	-8.73	Peak	HORIZONTAL

Remark:

- 1 The measured emissions between 9kHz to 30MHz are 20dB lower against the limit, so the result is not recorded in the report.
- 2 Measuring frequencies from the lowest internal frequency to the 1GHz.
- 3 Radiated emissions measured in frequency range from 9kHz to 1000MHz were made with an instrument detector setting 9-90kHz/110-490kHz using PK/AV and other Frequency Band using PK/QP
- 4 Measurement result within this frequency range shown “ - ” in the table above means the reading of emissions are attenuated more than 20dB below the permissible limits or the field strength is too small to be measured.

Radiated Spurious Emission Measurement Result (below 1GHz)

Operation Mode	TX MODE	Test Date	2020/01/21
Channel Number	CH High	Test By	Barry
Temperature	25	Pol	Ver./Hor
Humidity	65 %		

No	Freq MHz	Reading dBuV	Factor dB	Level dBuV/m	Limit dBuV/m	Margin dB	Remark	Pol V/H
1	75.59	40.73	-8.90	31.83	40.00	-8.17	Peak	VERTICAL
2	395.69	39.69	-2.08	37.61	46.00	-8.39	Peak	VERTICAL
3	500.45	40.21	-0.64	39.57	46.00	-6.43	Peak	VERTICAL
4	625.58	39.81	1.77	41.58	46.00	-4.42	Peak	VERTICAL
5	750.71	33.56	3.99	37.55	46.00	-8.45	Peak	VERTICAL
6	875.84	30.00	5.71	35.71	46.00	-10.29	Peak	VERTICAL
1	500.45	41.44	-0.64	40.80	46.00	-5.20	Peak	HORIZONTAL
2	600.36	32.58	1.52	34.10	46.00	-11.90	Peak	HORIZONTAL
3	625.58	38.08	1.77	39.85	46.00	-6.15	Peak	HORIZONTAL
4	755.56	31.10	4.11	35.21	46.00	-10.79	Peak	HORIZONTAL
5	875.84	30.98	5.71	36.69	46.00	-9.31	Peak	HORIZONTAL
6	934.04	30.56	6.62	37.18	46.00	-8.82	Peak	HORIZONTAL

Remark:

- 1 The measured emissions between 9kHz to 30MHz are 20dB lower against the limit, so the result is not recorded in the report.
- 2 Measuring frequencies from the lowest internal frequency to the 1GHz.
- 3 Radiated emissions measured in frequency range from 9kHz to 1000MHz were made with an instrument detector setting 9-90kHz/110-490kHz using PK/AV and other Frequency Band using PK/QP
- 4 Measurement result within this frequency range shown “ - ” in the table above means the reading of emissions are attenuated more than 20dB below the permissible limits or the field strength is too small to be measured.

**Radiated Spurious Emission Measurement Result (below 1GHz)
(Band UNII-2C, 802.11a mode)**

Operation Mode	TX MODE	Test Date	2020/01/21
Channel Number	CH Low	Test By	Barry
Temperature	25	Pol	Ver./Hor
Humidity	65 %		

No	Freq MHz	Reading dBuV	Factor dB	Level dBuV/m	Limit dBuV/m	Margin dB	Remark	Pol V/H
1	71.71	44.93	-8.21	36.72	40.00	-3.28	Peak	VERTICAL
2	375.32	38.76	-2.39	36.37	46.00	-9.63	Peak	VERTICAL
3	500.45	39.49	-0.64	38.85	46.00	-7.15	Peak	VERTICAL
4	625.58	39.31	1.77	41.08	46.00	-4.92	Peak	VERTICAL
5	750.71	33.81	3.99	37.80	46.00	-8.20	Peak	VERTICAL
6	929.19	29.74	6.57	36.31	46.00	-9.69	Peak	VERTICAL
1	436.43	31.69	-1.25	30.44	46.00	-15.56	Peak	HORIZONTAL
2	500.45	42.71	-0.64	42.07	46.00	-3.93	Peak	HORIZONTAL
3	596.48	33.33	1.44	34.77	46.00	-11.23	Peak	HORIZONTAL
4	625.58	37.45	1.77	39.22	46.00	-6.78	Peak	HORIZONTAL
5	875.84	32.39	5.71	38.10	46.00	-7.90	Peak	HORIZONTAL
6	944.71	30.29	6.80	37.09	46.00	-8.91	Peak	HORIZONTAL

Remark:

- 1 The measured emissions between 9kHz to 30MHz are 20dB lower against the limit, so the result is not recorded in the report.
- 2 Measuring frequencies from the lowest internal frequency to the 1GHz.
- 3 Radiated emissions measured in frequency range from 9kHz to 1000MHz were made with an instrument detector setting 9-90kHz/110-490kHz using PK/AV and other Frequency Band using PK/QP
- 4 Measurement result within this frequency range shown “ - ” in the table above means the reading of emissions are attenuated more than 20dB below the permissible limits or the field strength is too small to be measured.

Radiated Spurious Emission Measurement Result (below 1GHz)

Operation Mode	TX MODE	Test Date	2020/01/21
Channel Number	CH Mid	Test By	Barry
Temperature	25	Pol	Ver./Hor
Humidity	65 %		

No	Freq MHz	Reading dBuV	Factor dB	Level dBuV/m	Limit dBuV/m	Margin dB	Remark	Pol V/H
1	71.71	45.33	-8.21	37.12	40.00	-2.88	Peak	VERTICAL
2	375.32	38.75	-2.39	36.36	46.00	-9.64	Peak	VERTICAL
3	395.69	37.85	-2.08	35.77	46.00	-10.23	Peak	VERTICAL
4	500.45	38.90	-0.64	38.26	46.00	-7.74	Peak	VERTICAL
5	625.58	39.63	1.77	41.40	46.00	-4.60	Peak	VERTICAL
6	750.71	34.83	3.99	38.82	46.00	-7.18	Peak	VERTICAL
1	500.45	42.17	-0.64	41.53	46.00	-4.47	Peak	HORIZONTAL
2	515.00	37.07	-0.14	36.93	46.00	-9.07	Peak	HORIZONTAL
3	625.58	36.83	1.77	38.60	46.00	-7.40	Peak	HORIZONTAL
4	684.75	30.61	2.74	33.35	46.00	-12.65	Peak	HORIZONTAL
5	819.58	29.49	4.98	34.47	46.00	-11.53	Peak	HORIZONTAL
6	875.84	33.34	5.71	39.05	46.00	-6.95	Peak	HORIZONTAL

Remark:

- 1 The measured emissions between 9kHz to 30MHz are 20dB lower against the limit, so the result is not recorded in the report.
- 2 Measuring frequencies from the lowest internal frequency to the 1GHz.
- 3 Radiated emissions measured in frequency range from 9kHz to 1000MHz were made with an instrument detector setting 9-90kHz/110-490kHz using PK/AV and other Frequency Band using PK/QP
- 4 Measurement result within this frequency range shown “ - ” in the table above means the reading of emissions are attenuated more than 20dB below the permissible limits or the field strength is too small to be measured.

Radiated Spurious Emission Measurement Result (below 1GHz)

Operation Mode	TX MODE	Test Date	2020/01/21
Channel Number	CH High	Test By	Barry
Temperature	25	Pol	Ver./Hor
Humidity	65 %		

No	Freq MHz	Reading dBuV	Factor dB	Level dBuV/m	Limit dBuV/m	Margin dB	Remark	Pol V/H
1	71.71	42.57	-8.21	34.36	40.00	-5.64	Peak	VERTICAL
2	375.32	38.62	-2.39	36.23	46.00	-9.77	Peak	VERTICAL
3	395.69	39.63	-2.08	37.55	46.00	-8.45	Peak	VERTICAL
4	500.45	40.05	-0.64	39.41	46.00	-6.59	Peak	VERTICAL
5	625.58	40.06	1.77	41.83	46.00	-4.17	Peak	VERTICAL
6	750.71	34.26	3.99	38.25	46.00	-7.75	Peak	VERTICAL
1	284.14	33.62	-4.23	29.39	46.00	-16.61	Peak	HORIZONTAL
2	500.45	42.61	-0.64	41.97	46.00	-4.03	Peak	HORIZONTAL
3	625.58	37.58	1.77	39.35	46.00	-6.65	Peak	HORIZONTAL
4	777.87	29.85	4.38	34.23	46.00	-11.77	Peak	HORIZONTAL
5	812.79	30.41	4.88	35.29	46.00	-10.71	Peak	HORIZONTAL
6	875.84	31.42	5.71	37.13	46.00	-8.87	Peak	HORIZONTAL

Remark:

- 1 The measured emissions between 9kHz to 30MHz are 20dB lower against the limit, so the result is not recorded in the report.
- 2 Measuring frequencies from the lowest internal frequency to the 1GHz.
- 3 Radiated emissions measured in frequency range from 9kHz to 1000MHz were made with an instrument detector setting 9-90kHz/110-490kHz using PK/AV and other Frequency Band using PK/QP
- 4 Measurement result within this frequency range shown “ - ” in the table above means the reading of emissions are attenuated more than 20dB below the permissible limits or the field strength is too small to be measured.

**Radiated Spurious Emission Measurement Result (below 1GHz)
(Band UNII-2C, 802.11n HT40 mode)**

Operation Mode	TX MODE	Test Date	2020/01/21
Channel Number	CH Low	Test By	Barry
Temperature	25	Pol	Ver./Hor
Humidity	65 %		

No	Freq MHz	Reading dBuV	Factor dB	Level dBuV/m	Limit dBuV/m	Margin dB	Remark	Pol V/H
1	375.32	39.40	-2.39	37.01	46.00	-8.99	Peak	VERTICAL
2	395.69	36.88	-2.08	34.80	46.00	-11.20	Peak	VERTICAL
3	500.45	39.91	-0.64	39.27	46.00	-6.73	Peak	VERTICAL
4	625.58	39.41	1.77	41.18	46.00	-4.82	Peak	VERTICAL
5	750.71	34.23	3.99	38.22	46.00	-7.78	Peak	VERTICAL
6	875.84	30.89	5.71	36.60	46.00	-9.40	Peak	VERTICAL
1	395.69	31.54	-2.08	29.46	46.00	-16.54	Peak	HORIZONTAL
2	491.72	43.20	-0.71	42.49	46.00	-3.51	Peak	HORIZONTAL
3	500.45	41.91	-0.64	41.27	46.00	-4.73	Peak	HORIZONTAL
4	625.58	38.43	1.77	40.20	46.00	-5.80	Peak	HORIZONTAL
5	831.22	30.33	5.16	35.49	46.00	-10.51	Peak	HORIZONTAL
6	875.84	32.57	5.71	38.28	46.00	-7.72	Peak	HORIZONTAL

Remark:

- 1 The measured emissions between 9kHz to 30MHz are 20dB lower against the limit, so the result is not recorded in the report.
- 2 Measuring frequencies from the lowest internal frequency to the 1GHz.
- 3 Radiated emissions measured in frequency range from 9kHz to 1000MHz were made with an instrument detector setting 9-90kHz/110-490kHz using PK/AV and other Frequency Band using PK/QP
- 4 Measurement result within this frequency range shown “ - ” in the table above means the reading of emissions are attenuated more than 20dB below the permissible limits or the field strength is too small to be measured.

Radiated Spurious Emission Measurement Result (below 1GHz)

Operation Mode	TX MODE	Test Date	2020/01/21
Channel Number	CH Mid	Test By	Barry
Temperature	25	Pol	Ver./Hor
Humidity	65 %		

No	Freq MHz	Reading dBuV	Factor dB	Level dBuV/m	Limit dBuV/m	Margin dB	Remark	Pol V/H
1	73.65	42.89	-8.65	34.24	40.00	-5.76	Peak	VERTICAL
2	375.32	38.54	-2.39	36.15	46.00	-9.85	Peak	VERTICAL
3	395.69	37.42	-2.08	35.34	46.00	-10.66	Peak	VERTICAL
4	500.45	38.74	-0.64	38.10	46.00	-7.90	Peak	VERTICAL
5	625.58	38.65	1.77	40.42	46.00	-5.58	Peak	VERTICAL
6	750.71	34.43	3.99	38.42	46.00	-7.58	Peak	VERTICAL
1	395.69	32.17	-2.08	30.09	46.00	-15.91	Peak	HORIZONTAL
2	500.45	40.29	-0.64	39.65	46.00	-6.35	Peak	HORIZONTAL
3	517.91	35.37	-0.02	35.35	46.00	-10.65	Peak	HORIZONTAL
4	625.58	37.26	1.77	39.03	46.00	-6.97	Peak	HORIZONTAL
5	806.97	30.24	4.76	35.00	46.00	-11.00	Peak	HORIZONTAL
6	875.84	32.13	5.71	37.84	46.00	-8.16	Peak	HORIZONTAL

Remark:

- 1 The measured emissions between 9kHz to 30MHz are 20dB lower against the limit, so the result is not recorded in the report.
- 2 Measuring frequencies from the lowest internal frequency to the 1GHz.
- 3 Radiated emissions measured in frequency range from 9kHz to 1000MHz were made with an instrument detector setting 9-90kHz/110-490kHz using PK/AV and other Frequency Band using PK/QP
- 4 Measurement result within this frequency range shown “ - ” in the table above means the reading of emissions are attenuated more than 20dB below the permissible limits or the field strength is too small to be measured.

Radiated Spurious Emission Measurement Result (below 1GHz)

Operation Mode	TX MODE	Test Date	2020/01/21
Channel Number	CH High	Test By	Barry
Temperature	25	Pol	Ver./Hor
Humidity	65 %		

No	Freq MHz	Reading dBuV	Factor dB	Level dBuV/m	Limit dBuV/m	Margin dB	Remark	Pol V/H
1	71.71	45.12	-8.21	36.91	40.00	-3.09	Peak	VERTICAL
2	375.32	38.71	-2.39	36.32	46.00	-9.68	Peak	VERTICAL
3	395.69	37.33	-2.08	35.25	46.00	-10.75	Peak	VERTICAL
4	500.45	39.98	-0.64	39.34	46.00	-6.66	Peak	VERTICAL
5	625.58	39.52	1.77	41.29	46.00	-4.71	Peak	VERTICAL
6	750.71	33.45	3.99	37.44	46.00	-8.56	Peak	VERTICAL
1	395.69	32.16	-2.08	30.08	46.00	-15.92	Peak	HORIZONTAL
2	500.45	40.60	-0.64	39.96	46.00	-6.04	Peak	HORIZONTAL
3	596.48	33.69	1.44	35.13	46.00	-10.87	Peak	HORIZONTAL
4	625.58	37.50	1.77	39.27	46.00	-6.73	Peak	HORIZONTAL
5	765.26	30.69	4.24	34.93	46.00	-11.07	Peak	HORIZONTAL
6	875.84	32.72	5.71	38.43	46.00	-7.57	Peak	HORIZONTAL

Remark:

- 1 The measured emissions between 9kHz to 30MHz are 20dB lower against the limit, so the result is not recorded in the report.
- 2 Measuring frequencies from the lowest internal frequency to the 1GHz.
- 3 Radiated emissions measured in frequency range from 9kHz to 1000MHz were made with an instrument detector setting 9-90kHz/110-490kHz using PK/AV and other Frequency Band using PK/QP
- 4 Measurement result within this frequency range shown “ - ” in the table above means the reading of emissions are attenuated more than 20dB below the permissible limits or the field strength is too small to be measured.

**Radiated Spurious Emission Measurement Result (below 1GHz)
(Band UNII-2C, 802.11ac VHT80 mode)**

Operation Mode	TX MODE	Test Date	2020/01/21
Channel Number	CH Low	Test By	Barry
Temperature	25	Pol	Ver./Hor
Humidity	65 %		

No	Freq MHz	Reading dBuV	Factor dB	Level dBuV/m	Limit dBuV/m	Margin dB	Remark	Pol V/H
1	71.71	40.37	-8.21	32.16	40.00	-7.84	Peak	VERTICAL
2	375.32	39.26	-2.39	36.87	46.00	-9.13	Peak	VERTICAL
3	395.69	44.58	-2.08	42.50	46.00	-3.50	Peak	VERTICAL
4	500.45	38.55	-0.64	37.91	46.00	-8.09	Peak	VERTICAL
5	625.58	39.40	1.77	41.17	46.00	-4.83	Peak	VERTICAL
6	750.71	33.49	3.99	37.48	46.00	-8.52	Peak	VERTICAL
1	250.19	33.40	-5.51	27.89	46.00	-18.11	Peak	HORIZONTAL
2	395.69	34.71	-2.08	32.63	46.00	-13.37	Peak	HORIZONTAL
3	500.45	42.93	-0.64	42.29	46.00	-3.71	Peak	HORIZONTAL
4	625.58	38.27	1.77	40.04	46.00	-5.96	Peak	HORIZONTAL
5	784.66	30.08	4.42	34.50	46.00	-11.50	Peak	HORIZONTAL
6	875.84	32.60	5.71	38.31	46.00	-7.69	Peak	HORIZONTAL

Remark:

- 1 The measured emissions between 9kHz to 30MHz are 20dB lower against the limit, so the result is not recorded in the report.
- 2 Measuring frequencies from the lowest internal frequency to the 1GHz.
- 3 Radiated emissions measured in frequency range from 9kHz to 1000MHz were made with an instrument detector setting 9-90kHz/110-490kHz using PK/AV and other Frequency Band using PK/QP
- 4 Measurement result within this frequency range shown “ - ” in the table above means the reading of emissions are attenuated more than 20dB below the permissible limits or the field strength is too small to be measured.

Operation Mode	TX MODE	Test Date	2020/01/21
Channel Number	CH High	Test By	Barry
Temperature	25	Pol	Ver./Hor
Humidity	65 %		

No	Freq MHz	Reading dBuV	Factor dB	Level dBuV/m	Limit dBuV/m	Margin dB	Remark	Pol V/H
1	71.71	43.88	-8.21	35.67	40.00	-4.33	Peak	VERTICAL
2	375.32	38.26	-2.39	35.87	46.00	-10.13	Peak	VERTICAL
3	395.69	37.22	-2.08	35.14	46.00	-10.86	Peak	VERTICAL
4	500.45	38.49	-0.64	37.85	46.00	-8.15	Peak	VERTICAL
5	625.58	40.33	1.77	42.10	46.00	-3.90	Peak	VERTICAL
6	750.71	34.29	3.99	38.28	46.00	-7.72	Peak	VERTICAL
1	395.69	33.99	-2.08	31.91	46.00	-14.09	Peak	HORIZONTAL
2	500.45	41.17	-0.64	40.53	46.00	-5.47	Peak	HORIZONTAL
3	610.06	33.69	1.65	35.34	46.00	-10.66	Peak	HORIZONTAL
4	625.58	37.51	1.77	39.28	46.00	-6.72	Peak	HORIZONTAL
5	823.46	30.85	5.03	35.88	46.00	-10.12	Peak	HORIZONTAL
6	875.84	31.78	5.71	37.49	46.00	-8.51	Peak	HORIZONTAL

Remark:

- 1 The measured emissions between 9kHz to 30MHz are 20dB lower against the limit, so the result is not recorded in the report.
- 2 Measuring frequencies from the lowest internal frequency to the 1GHz.
- 3 Radiated emissions measured in frequency range from 9kHz to 1000MHz were made with an instrument detector setting 9-90kHz/110-490kHz using PK/AV and other Frequency Band using PK/QP
- 4 Measurement result within this frequency range shown “ - ” in the table above means the reading of emissions are attenuated more than 20dB below the permissible limits or the field strength is too small to be measured.

Radiated Spurious Emission Measurement Result (below 1GHz)

(Band UNII-3, 802.11a mode)

Operation Mode	TX MODE	Test Date	2020/01/21
Channel Number	CH Low	Test By	Barry
Temperature	25	Pol	Ver./Hor
Humidity	65 %		

No	Freq MHz	Reading dBuV	Factor dB	Level dBuV/m	Limit dBuV/m	Margin dB	Remark	Pol V/H
1	375.32	38.90	-2.39	36.51	46.00	-9.49	Peak	VERTICAL
2	395.69	38.71	-2.08	36.63	46.00	-9.37	Peak	VERTICAL
3	500.45	39.97	-0.64	39.33	46.00	-6.67	Peak	VERTICAL
4	625.58	38.84	1.77	40.61	46.00	-5.39	Peak	VERTICAL
5	750.71	33.09	3.99	37.08	46.00	-8.92	Peak	VERTICAL
6	875.84	31.17	5.71	36.88	46.00	-9.12	Peak	VERTICAL
1	395.69	32.13	-2.08	30.05	46.00	-15.95	Peak	HORIZONTAL
2	500.45	43.11	-0.64	42.47	46.00	-3.53	Peak	HORIZONTAL
3	578.05	33.15	0.95	34.10	46.00	-11.90	Peak	HORIZONTAL
4	625.58	37.46	1.77	39.23	46.00	-6.77	Peak	HORIZONTAL
5	843.83	29.97	5.31	35.28	46.00	-10.72	Peak	HORIZONTAL
6	875.84	32.51	5.71	38.22	46.00	-7.78	Peak	HORIZONTAL

Remark:

- 1 The measured emissions between 9kHz to 30MHz are 20dB lower against the limit, so the result is not recorded in the report.
- 2 Measuring frequencies from the lowest internal frequency to the 1GHz.
- 3 Radiated emissions measured in frequency range from 9kHz to 1000MHz were made with an instrument detector setting 9-90kHz/110-490kHz using PK/AV and other Frequency Band using PK/QP
- 4 Measurement result within this frequency range shown “ - ” in the table above means the reading of emissions are attenuated more than 20dB below the permissible limits or the field strength is too small to be measured.

Radiated Spurious Emission Measurement Result (below 1GHz)

Operation Mode	TX MODE	Test Date	2020/01/21
Channel Number	CH Mid	Test By	Barry
Temperature	25	Pol	Ver./Hor
Humidity	65 %		

No	Freq MHz	Reading dBuV	Factor dB	Level dBuV/m	Limit dBuV/m	Margin dB	Remark	Pol V/H
1	71.71	43.49	-8.21	35.28	40.00	-4.72	Peak	VERTICAL
2	395.69	40.68	-2.08	38.60	46.00	-7.40	Peak	VERTICAL
3	500.45	39.77	-0.64	39.13	46.00	-6.87	Peak	VERTICAL
4	625.58	39.27	1.77	41.04	46.00	-4.96	Peak	VERTICAL
5	750.71	33.69	3.99	37.68	46.00	-8.32	Peak	VERTICAL
6	875.84	32.41	5.71	38.12	46.00	-7.88	Peak	VERTICAL
1	395.69	32.19	-2.08	30.11	46.00	-15.89	Peak	HORIZONTAL
2	500.45	43.07	-0.64	42.43	46.00	-3.57	Peak	HORIZONTAL
3	516.94	35.19	-0.05	35.14	46.00	-10.86	Peak	HORIZONTAL
4	625.58	36.77	1.77	38.54	46.00	-7.46	Peak	HORIZONTAL
5	875.84	31.92	5.71	37.63	46.00	-8.37	Peak	HORIZONTAL
6	928.22	29.57	6.55	36.12	46.00	-9.88	Peak	HORIZONTAL

Remark:

- 1 The measured emissions between 9kHz to 30MHz are 20dB lower against the limit, so the result is not recorded in the report.
- 2 Measuring frequencies from the lowest internal frequency to the 1GHz.
- 3 Radiated emissions measured in frequency range from 9kHz to 1000MHz were made with an instrument detector setting 9-90kHz/110-490kHz using PK/AV and other Frequency Band using PK/QP
- 4 Measurement result within this frequency range shown “ - ” in the table above means the reading of emissions are attenuated more than 20dB below the permissible limits or the field strength is too small to be measured.

Radiated Spurious Emission Measurement Result (below 1GHz)

Operation Mode	TX MODE	Test Date	2020/01/21
Channel Number	CH High	Test By	Barry
Temperature	25	Pol	Ver./Hor
Humidity	65 %		

No	Freq MHz	Reading dBuV	Factor dB	Level dBuV/m	Limit dBuV/m	Margin dB	Remark	Pol V/H
1	71.71	44.22	-8.21	36.01	40.00	-3.99	Peak	VERTICAL
2	375.32	39.19	-2.39	36.80	46.00	-9.20	Peak	VERTICAL
3	395.69	37.23	-2.08	35.15	46.00	-10.85	Peak	VERTICAL
4	500.45	39.26	-0.64	38.62	46.00	-7.38	Peak	VERTICAL
5	625.58	38.95	1.77	40.72	46.00	-5.28	Peak	VERTICAL
6	750.71	34.03	3.99	38.02	46.00	-7.98	Peak	VERTICAL
1	489.78	35.60	-0.72	34.88	46.00	-11.12	Peak	HORIZONTAL
2	500.45	43.17	-0.64	42.53	46.00	-3.47	Peak	HORIZONTAL
3	509.18	37.97	-0.36	37.61	46.00	-8.39	Peak	HORIZONTAL
4	625.58	38.28	1.77	40.05	46.00	-5.95	Peak	HORIZONTAL
5	832.19	29.61	5.17	34.78	46.00	-11.22	Peak	HORIZONTAL
6	875.84	32.11	5.71	37.82	46.00	-8.18	Peak	HORIZONTAL

Remark:

- 1 The measured emissions between 9kHz to 30MHz are 20dB lower against the limit, so the result is not recorded in the report.
- 2 Measuring frequencies from the lowest internal frequency to the 1GHz.
- 3 Radiated emissions measured in frequency range from 9kHz to 1000MHz were made with an instrument detector setting 9-90kHz/110-490kHz using PK/AV and other Frequency Band using PK/QP
- 4 Measurement result within this frequency range shown “ - ” in the table above means the reading of emissions are attenuated more than 20dB below the permissible limits or the field strength is too small to be measured.

Radiated Spurious Emission Measurement Result (below 1GHz)
(Band UNII-3, 802.11n HT40 mode)

Operation Mode	TX MODE	Test Date	2020/01/21
Channel Number	CH Low	Test By	Barry
Temperature	25	Pol	Ver./Hor
Humidity	65 %		

No	Freq MHz	Reading dBuV	Factor dB	Level dBuV/m	Limit dBuV/m	Margin dB	Remark	Pol V/H
1	71.71	42.64	-8.21	34.43	40.00	-5.57	Peak	VERTICAL
2	375.32	38.59	-2.39	36.20	46.00	-9.80	Peak	VERTICAL
3	395.69	37.38	-2.08	35.30	46.00	-10.70	Peak	VERTICAL
4	500.45	39.34	-0.64	38.70	46.00	-7.30	Peak	VERTICAL
5	625.58	39.75	1.77	41.52	46.00	-4.48	Peak	VERTICAL
6	750.71	34.18	3.99	38.17	46.00	-7.83	Peak	VERTICAL
1	489.78	37.06	-0.72	36.34	46.00	-9.66	Peak	HORIZONTAL
2	500.45	43.61	-0.64	42.97	46.00	-3.03	Peak	HORIZONTAL
3	520.82	39.85	0.08	39.93	46.00	-6.07	Peak	HORIZONTAL
4	625.58	38.50	1.77	40.27	46.00	-5.73	Peak	HORIZONTAL
5	840.92	30.11	5.29	35.40	46.00	-10.60	Peak	HORIZONTAL
6	875.84	32.09	5.71	37.80	46.00	-8.20	Peak	HORIZONTAL

Remark:

- 1 The measured emissions between 9kHz to 30MHz are 20dB lower against the limit, so the result is not recorded in the report.
- 2 Measuring frequencies from the lowest internal frequency to the 1GHz.
- 3 Radiated emissions measured in frequency range from 9kHz to 1000MHz were made with an instrument detector setting 9-90kHz/110-490kHz using PK/AV and other Frequency Band using PK/QP
- 4 Measurement result within this frequency range shown “ - ” in the table above means the reading of emissions are attenuated more than 20dB below the permissible limits or the field strength is too small to be measured.

Radiated Spurious Emission Measurement Result (below 1GHz)

Operation Mode	TX MODE	Test Date	2020/01/21
Channel Number	CH High	Test By	Barry
Temperature	25	Pol	Ver./Hor
Humidity	65 %		

No	Freq MHz	Reading dBuV	Factor dB	Level dBuV/m	Limit dBuV/m	Margin dB	Remark	Pol V/H
1	77.53	39.97	-9.43	30.54	40.00	-9.46	Peak	VERTICAL
2	375.32	38.77	-2.39	36.38	46.00	-9.62	Peak	VERTICAL
3	395.69	42.33	-2.08	40.25	46.00	-5.75	Peak	VERTICAL
4	500.45	38.82	-0.64	38.18	46.00	-7.82	Peak	VERTICAL
5	625.58	39.54	1.77	41.31	46.00	-4.69	Peak	VERTICAL
6	750.71	34.61	3.99	38.60	46.00	-7.40	Peak	VERTICAL
1	481.05	35.96	-0.87	35.09	46.00	-10.91	Peak	HORIZONTAL
2	500.45	42.87	-0.64	42.23	46.00	-3.77	Peak	HORIZONTAL
3	527.61	35.86	0.22	36.08	46.00	-9.92	Peak	HORIZONTAL
4	625.58	37.05	1.77	38.82	46.00	-7.18	Peak	HORIZONTAL
5	750.71	30.08	3.99	34.07	46.00	-11.93	Peak	HORIZONTAL
6	875.84	32.32	5.71	38.03	46.00	-7.97	Peak	HORIZONTAL

Remark:

- 1 The measured emissions between 9kHz to 30MHz are 20dB lower against the limit, so the result is not recorded in the report.
- 2 Measuring frequencies from the lowest internal frequency to the 1GHz.
- 3 Radiated emissions measured in frequency range from 9kHz to 1000MHz were made with an instrument detector setting 9-90kHz/110-490kHz using PK/AV and other Frequency Band using PK/QP
- 4 Measurement result within this frequency range shown “ - ” in the table above means the reading of emissions are attenuated more than 20dB below the permissible limits or the field strength is too small to be measured.

**Radiated Spurious Emission Measurement Result (below 1GHz)
(Band UNII-3, 802.11ac VHT80 mode)**

Operation Mode	TX MODE	Test Date	2020/01/21
Channel Number	CH Low	Test By	Barry
Temperature	25	Pol	Ver./Hor
Humidity	65 %		

No	Freq MHz	Reading dBuV	Factor dB	Level dBuV/m	Limit dBuV/m	Margin dB	Remark	Pol V/H
1	71.71	43.98	-8.21	35.77	40.00	-4.23	Peak	VERTICAL
2	395.69	44.91	-2.08	42.83	46.00	-3.17	Peak	VERTICAL
3	500.45	39.29	-0.64	38.65	46.00	-7.35	Peak	VERTICAL
4	625.58	39.37	1.77	41.14	46.00	-4.86	Peak	VERTICAL
5	750.71	33.53	3.99	37.52	46.00	-8.48	Peak	VERTICAL
6	875.84	30.66	5.71	36.37	46.00	-9.63	Peak	VERTICAL
1	500.45	43.31	-0.64	42.67	46.00	-3.33	Peak	HORIZONTAL
2	511.12	37.25	-0.31	36.94	46.00	-9.06	Peak	HORIZONTAL
3	518.88	36.91	0.02	36.93	46.00	-9.07	Peak	HORIZONTAL
4	600.36	32.68	1.52	34.20	46.00	-11.80	Peak	HORIZONTAL
5	625.58	37.74	1.77	39.51	46.00	-6.49	Peak	HORIZONTAL
6	875.84	31.59	5.71	37.30	46.00	-8.70	Peak	HORIZONTAL

Remark:

- 1 The measured emissions between 9kHz to 30MHz are 20dB lower against the limit, so the result is not recorded in the report.
- 2 Measuring frequencies from the lowest internal frequency to the 1GHz.
- 3 Radiated emissions measured in frequency range from 9kHz to 1000MHz were made with an instrument detector setting 9-90kHz/110-490kHz using PK/AV and other Frequency Band using PK/QP
- 4 Measurement result within this frequency range shown “ - ” in the table above means the reading of emissions are attenuated more than 20dB below the permissible limits or the field strength is too small to be measured.

PIFA Ant

Radiated Spurious Emission Measurement Result (above 1GHz)

(Band UNII-1 / Band UNII-2A, 802.11a mode)

Operation Mode	TX MODE	Test Date	2020/04/07
Channel Number	CH Low	Test By	Barry
Temperature	25	Humidity	60 %

No	Freq MHz	Reading dBuV	Factor dB	Level dBuV/m	Limit dBuV/m	Margin dB	Remark	Pol V/H
1	3632.00	48.63	-13.16	35.47	74.00	-38.53	Peak	VERTICAL
2	4556.00	47.05	-10.07	36.98	74.00	-37.02	Peak	VERTICAL
3	10360.00	37.50	4.18	41.68	68.20	-26.52	Peak	VERTICAL
4	15540.00	36.56	7.94	44.50	74.00	-29.50	Peak	VERTICAL
1	2393.00	48.58	-15.70	32.88	68.20	-35.32	Peak	HORIZONTAL
2	3646.00	48.35	-13.14	35.21	74.00	-38.79	Peak	HORIZONTAL
3	10360.00	38.15	4.18	42.33	68.20	-25.87	Peak	HORIZONTAL
4	15540.00	37.61	7.94	45.55	74.00	-28.45	Peak	HORIZONTAL

Remark:

- 1 Field strength limits for frequency above 1000MHz are based on average limits. However, Peak mode field strength shall not exceed the average limits specified plus 20dB.
- 2 Measurement of data within this frequency range shown “ - ” in the table above means the reading of emissions are attenuated more than 20dB below the permissible limits or the field strength is too small to be measured.

Radiated Spurious Emission Measurement Result (above 1GHz)

Operation Mode	TX MODE	Test Date	2020/04/07
Channel Number	CH Mid	Test By	Barry
Temperature	25	Humidity	60 %

No	Freq MHz	Reading dBuV	Factor dB	Level dBuV/m	Limit dBuV/m	Margin dB	Remark	Pol V/H
1	2540.00	49.58	-15.57	34.01	68.20	-34.19	Peak	VERTICAL
2	3562.00	48.12	-13.39	34.73	68.20	-33.47	Peak	VERTICAL
3	10520.00	36.65	4.63	41.28	68.20	-26.92	Peak	VERTICAL
4	15780.00	36.04	7.15	43.19	74.00	-30.81	Peak	VERTICAL
1	3065.00	48.37	-14.37	34.00	68.20	-34.20	Peak	HORIZONTAL
2	4563.00	47.98	-10.05	37.93	74.00	-36.07	Peak	HORIZONTAL
3	10520.00	36.96	4.63	41.59	68.20	-26.61	Peak	HORIZONTAL
4	15780.00	35.64	7.15	42.79	74.00	-31.21	Peak	HORIZONTAL

Remark:

- 1 Field strength limits for frequency above 1000MHz are based on average limits. However, Peak mode field strength shall not exceed the average limits specified plus 20dB.
- 2 Measurement of data within this frequency range shown “ - ” in the table above means the reading of emissions are attenuated more than 20dB below the permissible limits or the field strength is too small to be measured.

Radiated Spurious Emission Measurement Result (above 1GHz)

Operation Mode	TX MODE	Test Date	2020/04/07
Channel Number	CH High	Test By	Barry
Temperature	25	Humidity	60 %

No	Freq MHz	Reading dBuV	Factor dB	Level dBuV/m	Limit dBuV/m	Margin dB	Remark	Pol V/H
1	3058.00	48.52	-14.39	34.13	68.20	-34.07	Peak	VERTICAL
2	3639.00	48.85	-13.15	35.70	74.00	-38.30	Peak	VERTICAL
3	10640.00	37.97	5.01	42.98	74.00	-31.02	Peak	VERTICAL
4	15960.00	35.96	6.56	42.52	74.00	-31.48	Peak	VERTICAL
1	3051.00	48.64	-14.41	34.23	68.20	-33.97	Peak	HORIZONTAL
2	4759.00	47.42	-9.36	38.06	74.00	-35.94	Peak	HORIZONTAL
3	10640.00	36.94	5.01	41.95	74.00	-32.05	Peak	HORIZONTAL
4	15960.00	38.55	6.56	45.11	74.00	-28.89	Peak	HORIZONTAL

Remark:

- 1 Field strength limits for frequency above 1000MHz are based on average limits. However, Peak mode field strength shall not exceed the average limits specified plus 20dB.
- 2 Measurement of data within this frequency range shown “ - ” in the table above means the reading of emissions are attenuated more than 20dB below the permissible limits or the field strength is too small to be measured.

**Radiated Spurious Emission Measurement Result (above 1GHz)
(Band UNII-1 / Band UNII-2A, 802.11n HT40 mode)**

Operation Mode	TX MODE	Test Date	2020/04/07
Channel Number	CH Low	Test By	Barry
Temperature	25	Humidity	60 %

No	Freq MHz	Reading dBuV	Factor dB	Level dBuV/m	Limit dBuV/m	Margin dB	Remark	Pol V/H
1	2820.00	49.14	-15.04	34.10	74.00	-39.90	Peak	VERTICAL
2	4710.00	46.05	-9.49	36.56	74.00	-37.44	Peak	VERTICAL
3	10380.00	38.58	4.25	42.83	68.20	-25.37	Peak	VERTICAL
4	15570.00	38.04	7.85	45.89	74.00	-28.11	Peak	VERTICAL
1	2281.00	49.42	-15.60	33.82	74.00	-40.18	Peak	HORIZONTAL
2	4059.00	47.54	-11.73	35.81	74.00	-38.19	Peak	HORIZONTAL
3	10380.00	37.28	4.25	41.53	68.20	-26.67	Peak	HORIZONTAL
4	15570.00	38.95	7.85	46.80	74.00	-27.20	Peak	HORIZONTAL

Remark:

- 1 Field strength limits for frequency above 1000MHz are based on average limits. However, Peak mode field strength shall not exceed the average limits specified plus 20dB.
- 2 Measurement of data within this frequency range shown “ - ” in the table above means the reading of emissions are attenuated more than 20dB below the permissible limits or the field strength is too small to be measured.

Radiated Spurious Emission Measurement Result (above 1GHz)

Operation Mode	TX MODE	Test Date	2020/04/07
Channel Number	CH Mid	Test By	Barry
Temperature	25	Humidity	60 %

No	Freq MHz	Reading dBuV	Factor dB	Level dBuV/m	Limit dBuV/m	Margin dB	Remark	Pol V/H
1	3086.00	48.84	-14.31	34.53	68.20	-33.67	Peak	VERTICAL
2	4269.00	47.12	-11.08	36.04	74.00	-37.96	Peak	VERTICAL
3	10540.00	36.43	4.70	41.13	68.20	-27.07	Peak	VERTICAL
4	15810.00	38.76	7.04	45.80	74.00	-28.20	Peak	VERTICAL
1	2624.00	48.34	-15.36	32.98	68.20	-35.22	Peak	HORIZONTAL
2	4171.00	47.46	-11.38	36.08	74.00	-37.92	Peak	HORIZONTAL
3	10540.00	39.10	4.70	43.80	68.20	-24.40	Peak	HORIZONTAL
4	15810.00	38.68	7.04	45.72	74.00	-28.28	Peak	HORIZONTAL

Remark:

- 1 Field strength limits for frequency above 1000MHz are based on average limits. However, Peak mode field strength shall not exceed the average limits specified plus 20dB.
- 2 Measurement of data within this frequency range shown “ - ” in the table above means the reading of emissions are attenuated more than 20dB below the permissible limits or the field strength is too small to be measured.

Radiated Spurious Emission Measurement Result (above 1GHz)

Operation Mode	TX MODE	Test Date	2020/04/07
Channel Number	CH High	Test By	Barry
Temperature	25	Humidity	60 %

No	Freq MHz	Reading dBuV	Factor dB	Level dBuV/m	Limit dBuV/m	Margin dB	Remark	Pol V/H
1	1182.00	55.76	-19.90	35.86	74.00	-38.14	Peak	VERTICAL
2	4129.00	47.43	-11.52	35.91	74.00	-38.09	Peak	VERTICAL
3	10620.00	35.52	4.95	40.47	74.00	-33.53	Peak	VERTICAL
4	15930.00	37.14	6.65	43.79	74.00	-30.21	Peak	VERTICAL
1	1182.00	54.28	-19.90	34.38	74.00	-39.62	Peak	HORIZONTAL
2	3009.00	49.87	-14.54	35.33	68.20	-32.87	Peak	HORIZONTAL
3	10620.00	37.42	4.95	42.37	74.00	-31.63	Peak	HORIZONTAL
4	15930.00	38.20	6.65	44.85	74.00	-29.15	Peak	HORIZONTAL

Remark:

- 1 Field strength limits for frequency above 1000MHz are based on average limits. However, Peak mode field strength shall not exceed the average limits specified plus 20dB.
- 2 Measurement of data within this frequency range shown “ - ” in the table above means the reading of emissions are attenuated more than 20dB below the permissible limits or the field strength is too small to be measured.

**Radiated Spurious Emission Measurement Result (above 1GHz)
(Band UNII-1 / Band UNII-2A, 802.11ac VHT80 mode)**

Operation Mode	TX MODE	Test Date	2020/04/07
Channel Number	CH Low	Test By	Barry
Temperature	25	Humidity	60 %

No	Freq MHz	Reading dBuV	Factor dB	Level dBuV/m	Limit dBuV/m	Margin dB	Remark	Pol V/H
1	2470.00	48.47	-15.70	32.77	68.20	-35.43	Peak	VERTICAL
2	3611.00	49.03	-13.22	35.81	74.00	-38.19	Peak	VERTICAL
3	10420.00	37.29	4.36	41.65	68.20	-26.55	Peak	VERTICAL
4	15630.00	33.04	7.65	40.69	74.00	-33.31	Peak	VERTICAL
1	2421.00	49.03	-15.71	33.32	68.20	-34.88	Peak	HORIZONTAL
2	4164.00	47.36	-11.40	35.96	74.00	-38.04	Peak	HORIZONTAL
3	10420.00	37.30	4.36	41.66	68.20	-26.54	Peak	HORIZONTAL
4	15630.00	35.26	7.65	42.91	74.00	-31.09	Peak	HORIZONTAL

Remark:

- 1 Field strength limits for frequency above 1000MHz are based on average limits. However, Peak mode field strength shall not exceed the average limits specified plus 20dB.
- 2 Measurement of data within this frequency range shown “ - ” in the table above means the reading of emissions are attenuated more than 20dB below the permissible limits or the field strength is too small to be measured.

Radiated Spurious Emission Measurement Result (above 1GHz)

Operation Mode	TX MODE	Test Date	2020/04/07
Channel Number	CH High	Test By	Barry
Temperature	25	Humidity	60 %

No	Freq MHz	Reading dBuV	Factor dB	Level dBuV/m	Limit dBuV/m	Margin dB	Remark	Pol V/H
1	3478.00	47.42	-13.81	33.61	68.20	-34.59	Peak	VERTICAL
2	4570.00	47.11	-10.03	37.08	74.00	-36.92	Peak	VERTICAL
3	10580.00	38.41	4.82	43.23	68.20	-24.97	Peak	VERTICAL
4	15780.00	35.99	7.15	43.14	74.00	-30.86	Peak	VERTICAL
1	3604.00	48.28	-13.24	35.04	74.00	-38.96	Peak	HORIZONTAL
2	4787.00	48.04	-9.28	38.76	74.00	-35.24	Peak	HORIZONTAL
3	10580.00	38.74	4.82	43.56	68.20	-24.64	Peak	HORIZONTAL
4	15780.00	37.37	7.15	44.52	74.00	-29.48	Peak	HORIZONTAL

Remark:

- 1 Field strength limits for frequency above 1000MHz are based on average limits. However, Peak mode field strength shall not exceed the average limits specified plus 20dB.
- 2 Measurement of data within this frequency range shown “ - ” in the table above means the reading of emissions are attenuated more than 20dB below the permissible limits or the field strength is too small to be measured.

Radiated Spurious Emission Measurement Result (above 1GHz)

(Band UNII-2C, 802.11a mode)

Operation Mode	TX MODE	Test Date	2020/04/07
Channel Number	CH Low	Test By	Barry
Temperature	25	Humidity	60 %

No	Freq MHz	Reading dBuV	Factor dB	Level dBuV/m	Limit dBuV/m	Margin dB	Remark	Pol V/H
1	2918.00	49.21	-14.81	34.40	68.20	-33.80	Peak	VERTICAL
2	4563.00	46.67	-10.05	36.62	74.00	-37.38	Peak	VERTICAL
3	11000.00	37.28	6.12	43.40	74.00	-30.60	Peak	VERTICAL
4	16500.00	38.19	7.71	45.90	68.20	-22.30	Peak	VERTICAL
1	3191.00	47.91	-14.32	33.59	68.20	-34.61	Peak	HORIZONTAL
2	4129.00	47.23	-11.52	35.71	74.00	-38.29	Peak	HORIZONTAL
3	11000.00	36.89	6.12	43.01	74.00	-30.99	Peak	HORIZONTAL
4	16500.00	39.55	7.71	47.26	68.20	-20.94	Peak	HORIZONTAL

Remark:

- 1 Field strength limits for frequency above 1000MHz are based on average limits. However, Peak mode field strength shall not exceed the average limits specified plus 20dB.
- 2 Measurement of data within this frequency range shown “ - ” in the table above means the reading of emissions are attenuated more than 20dB below the permissible limits or the field strength is too small to be measured.

Radiated Spurious Emission Measurement Result (above 1GHz)

Operation Mode	TX MODE	Test Date	2020/04/07
Channel Number	CH Mid	Test By	Barry
Temperature	25	Humidity	60 %

No	Freq MHz	Reading dBuV	Factor dB	Level dBuV/m	Limit dBuV/m	Margin dB	Remark	Pol V/H
1	2428.00	50.30	-15.71	34.59	68.20	-33.61	Peak	VERTICAL
2	4619.00	45.92	-9.85	36.07	74.00	-37.93	Peak	VERTICAL
3	11200.00	35.90	6.28	42.18	74.00	-31.82	Peak	VERTICAL
4	16800.00	35.23	8.72	43.95	68.20	-24.25	Peak	VERTICAL
1	3667.00	48.48	-13.09	35.39	74.00	-38.61	Peak	HORIZONTAL
2	4759.00	45.58	-9.36	36.22	74.00	-37.78	Peak	HORIZONTAL
3	11200.00	38.02	6.28	44.30	74.00	-29.70	Peak	HORIZONTAL
4	16800.00	40.22	8.72	48.94	68.20	-19.26	Peak	HORIZONTAL

Remark:

- 1 Field strength limits for frequency above 1000MHz are based on average limits. However, Peak mode field strength shall not exceed the average limits specified plus 20dB.
- 2 Measurement of data within this frequency range shown “ - ” in the table above means the reading of emissions are attenuated more than 20dB below the permissible limits or the field strength is too small to be measured.

Radiated Spurious Emission Measurement Result (above 1GHz)

Operation Mode	TX MODE	Test Date	2020/04/07
Channel Number	CH High	Test By	Barry
Temperature	25	Humidity	60 %

No	Freq MHz	Reading dBuV	Factor dB	Level dBuV/m	Limit dBuV/m	Margin dB	Remark	Pol V/H
1	1182.00	53.44	-19.90	33.54	74.00	-40.46	Peak	VERTICAL
2	3541.00	48.66	-13.48	35.18	68.20	-33.02	Peak	VERTICAL
3	11400.00	38.16	6.44	44.60	74.00	-29.40	Peak	VERTICAL
4	17100.00	35.83	10.29	46.12	68.20	-22.08	Peak	VERTICAL
1	3128.00	48.88	-14.29	34.59	68.20	-33.61	Peak	HORIZONTAL
2	4136.00	48.33	-11.49	36.84	74.00	-37.16	Peak	HORIZONTAL
3	11400.00	35.72	6.44	42.16	74.00	-31.84	Peak	HORIZONTAL
4	17100.00	35.31	10.29	45.60	68.20	-22.60	Peak	HORIZONTAL

Remark:

- 1 Field strength limits for frequency above 1000MHz are based on average limits. However, Peak mode field strength shall not exceed the average limits specified plus 20dB.
- 2 Measurement of data within this frequency range shown “ - ” in the table above means the reading of emissions are attenuated more than 20dB below the permissible limits or the field strength is too small to be measured.

**Radiated Spurious Emission Measurement Result (above 1GHz)
(Band UNII-2C, 802.11n HT40 mode)**

Operation Mode	TX MODE	Test Date	2020/04/07
Channel Number	CH Low	Test By	Barry
Temperature	25	Humidity	60 %

No	Freq MHz	Reading dBuV	Factor dB	Level dBuV/m	Limit dBuV/m	Margin dB	Remark	Pol V/H
1	1182.00	53.62	-19.90	33.72	74.00	-40.28	Peak	VERTICAL
2	4059.00	47.81	-11.73	36.08	74.00	-37.92	Peak	VERTICAL
3	11020.00	33.65	6.13	39.78	74.00	-34.22	Peak	VERTICAL
4	16530.00	36.66	7.82	44.48	68.20	-23.72	Peak	VERTICAL
1	1182.00	52.61	-19.90	32.71	74.00	-41.29	Peak	HORIZONTAL
2	4031.00	47.53	-11.81	35.72	74.00	-38.28	Peak	HORIZONTAL
3	11020.00	36.83	6.13	42.96	74.00	-31.04	Peak	HORIZONTAL
4	16530.00	36.06	7.82	43.88	68.20	-24.32	Peak	HORIZONTAL

Remark:

- 1 Field strength limits for frequency above 1000MHz are based on average limits. However, Peak mode field strength shall not exceed the average limits specified plus 20dB.
- 2 Measurement of data within this frequency range shown “ - ” in the table above means the reading of emissions are attenuated more than 20dB below the permissible limits or the field strength is too small to be measured.

Radiated Spurious Emission Measurement Result (above 1GHz)

Operation Mode	TX MODE	Test Date	2020/04/07
Channel Number	CH Mid	Test By	Barry
Temperature	25	Humidity	60 %

No	Freq MHz	Reading dBuV	Factor dB	Level dBuV/m	Limit dBuV/m	Margin dB	Remark	Pol V/H
1	2043.00	49.52	-17.16	32.36	68.20	-35.84	Peak	VERTICAL
2	4073.00	47.53	-11.69	35.84	74.00	-38.16	Peak	VERTICAL
3	11180.00	36.16	6.27	42.43	74.00	-31.57	Peak	VERTICAL
4	16770.00	36.25	8.62	44.87	68.20	-23.33	Peak	VERTICAL
1	2939.00	48.26	-14.74	33.52	68.20	-34.68	Peak	HORIZONTAL
2	4787.00	46.26	-9.28	36.98	74.00	-37.02	Peak	HORIZONTAL
3	11180.00	37.89	6.27	44.16	74.00	-29.84	Peak	HORIZONTAL
4	16770.00	36.04	8.62	44.66	68.20	-23.54	Peak	HORIZONTAL

Remark:

- 1 Field strength limits for frequency above 1000MHz are based on average limits. However, Peak mode field strength shall not exceed the average limits specified plus 20dB.
- 2 Measurement of data within this frequency range shown “ - ” in the table above means the reading of emissions are attenuated more than 20dB below the permissible limits or the field strength is too small to be measured.

Radiated Spurious Emission Measurement Result (above 1GHz)

Operation Mode	TX MODE	Test Date	2020/04/07
Channel Number	CH High	Test By	Barry
Temperature	25	Humidity	60 %

No	Freq MHz	Reading dBuV	Factor dB	Level dBuV/m	Limit dBuV/m	Margin dB	Remark	Pol V/H
1	1182.00	54.14	-19.90	34.24	74.00	-39.76	Peak	VERTICAL
2	3023.00	47.69	-14.50	33.19	68.20	-35.01	Peak	VERTICAL
3	11340.00	34.12	6.39	40.51	74.00	-33.49	Peak	VERTICAL
4	17010.00	34.02	9.49	43.51	68.20	-24.69	Peak	VERTICAL
1	1182.00	56.27	-19.90	36.37	74.00	-37.63	Peak	HORIZONTAL
2	3639.00	47.81	-13.15	34.66	74.00	-39.34	Peak	HORIZONTAL
3	11340.00	35.48	6.39	41.87	74.00	-32.13	Peak	HORIZONTAL
4	17010.00	35.76	9.49	45.25	68.20	-22.95	Peak	HORIZONTAL

Remark:

- 1 Field strength limits for frequency above 1000MHz are based on average limits. However, Peak mode field strength shall not exceed the average limits specified plus 20dB.
- 2 Measurement of data within this frequency range shown “ - ” in the table above means the reading of emissions are attenuated more than 20dB below the permissible limits or the field strength is too small to be measured.

Radiated Spurious Emission Measurement Result (above 1GHz)
(Band UNII-2C, 802.11ac VHT80 mode)

Operation Mode	TX MODE	Test Date	2020/04/07
Channel Number	CH Low	Test By	Barry
Temperature	25	Humidity	60 %

No	Freq MHz	Reading dBuV	Factor dB	Level dBuV/m	Limit dBuV/m	Margin dB	Remark	Pol V/H
1	2533.00	49.16	-15.59	33.57	68.20	-34.63	Peak	VERTICAL
2	4059.00	47.30	-11.73	35.57	74.00	-38.43	Peak	VERTICAL
3	11060.00	33.47	6.17	39.64	74.00	-34.36	Peak	VERTICAL
4	16590.00	34.49	8.02	42.51	68.20	-25.69	Peak	VERTICAL
1	1182.00	55.04	-19.90	35.14	74.00	-38.86	Peak	HORIZONTAL
2	4150.00	47.71	-11.44	36.27	74.00	-37.73	Peak	HORIZONTAL
3	11060.00	34.87	6.17	41.04	74.00	-32.96	Peak	HORIZONTAL
4	16590.00	34.24	8.02	42.26	68.20	-25.94	Peak	HORIZONTAL

Remark:

- 1 Field strength limits for frequency above 1000MHz are based on average limits. However, Peak mode field strength shall not exceed the average limits specified plus 20dB.
- 2 Measurement of data within this frequency range shown “ - ” in the table above means the reading of emissions are attenuated more than 20dB below the permissible limits or the field strength is too small to be measured.

Radiated Spurious Emission Measurement Result (above 1GHz)

Operation Mode	TX MODE	Test Date	2020/04/07
Channel Number	CH High	Test By	Barry
Temperature	25	Humidity	60 %

No	Freq MHz	Reading dBuV	Factor dB	Level dBuV/m	Limit dBuV/m	Margin dB	Remark	Pol V/H
1	1182.00	55.53	-19.90	35.63	74.00	-38.37	Peak	VERTICAL
2	4101.00	47.55	-11.59	35.96	74.00	-38.04	Peak	VERTICAL
3	11220.00	33.99	6.29	40.28	74.00	-33.72	Peak	VERTICAL
4	16830.00	33.84	8.83	42.67	68.20	-25.53	Peak	VERTICAL
1	2288.00	48.89	-15.61	33.28	74.00	-40.72	Peak	HORIZONTAL
2	4584.00	46.44	-9.98	36.46	74.00	-37.54	Peak	HORIZONTAL
3	11220.00	36.62	6.29	42.91	74.00	-31.09	Peak	HORIZONTAL
4	16830.00	36.14	8.83	44.97	68.20	-23.23	Peak	HORIZONTAL

Remark:

- 1 Field strength limits for frequency above 1000MHz are based on average limits. However, Peak mode field strength shall not exceed the average limits specified plus 20dB.
- 2 Measurement of data within this frequency range shown “ - ” in the table above means the reading of emissions are attenuated more than 20dB below the permissible limits or the field strength is too small to be measured.

**Radiated Spurious Emission Measurement Result (above 1GHz)
(Band UNII-3, 802.11a mode)**

Operation Mode	TX MODE	Test Date	2020/04/07
Channel Number	CH Low	Test By	Barry
Temperature	25	Humidity	60 %

No	Freq MHz	Reading dBuV	Factor dB	Level dBuV/m	Limit dBuV/m	Margin dB	Remark	Pol V/H
1	1182.00	56.14	-19.90	36.24	74.00	-37.76	Peak	VERTICAL
2	3044.00	49.34	-14.43	34.91	68.20	-33.29	Peak	VERTICAL
3	11490.00	37.12	6.52	43.64	74.00	-30.36	Peak	VERTICAL
4	17235.00	37.67	11.50	49.17	68.20	-19.03	Peak	VERTICAL
1	3079.00	48.23	-14.33	33.90	68.20	-34.30	Peak	HORIZONTAL
2	4066.00	47.43	-11.70	35.73	74.00	-38.27	Peak	HORIZONTAL
3	11490.00	36.08	6.52	42.60	74.00	-31.40	Peak	HORIZONTAL
4	17235.00	35.88	11.50	47.38	68.20	-20.82	Peak	HORIZONTAL

Remark:

- 1 Field strength limits for frequency above 1000MHz are based on average limits. However, Peak mode field strength shall not exceed the average limits specified plus 20dB.
- 2 Measurement of data within this frequency range shown “ - ” in the table above means the reading of emissions are attenuated more than 20dB below the permissible limits or the field strength is too small to be measured.

Radiated Spurious Emission Measurement Result (above 1GHz)

Operation Mode	TX MODE	Test Date	2020/04/07
Channel Number	CH Mid	Test By	Barry
Temperature	25	Humidity	60 %

No	Freq MHz	Reading dBuV	Factor dB	Level dBuV/m	Limit dBuV/m	Margin dB	Remark	Pol V/H
1	1182.00	53.88	-19.90	33.98	74.00	-40.02	Peak	VERTICAL
2	3646.00	48.87	-13.14	35.73	74.00	-38.27	Peak	VERTICAL
3	11570.00	33.25	6.54	39.79	74.00	-34.21	Peak	VERTICAL
4	17355.00	34.55	12.56	47.11	68.20	-21.09	Peak	VERTICAL
1	1182.00	52.98	-19.90	33.08	74.00	-40.92	Peak	HORIZONTAL
2	3639.00	48.43	-13.15	35.28	74.00	-38.72	Peak	HORIZONTAL
3	11570.00	35.23	6.54	41.77	74.00	-32.23	Peak	HORIZONTAL
4	17355.00	33.06	12.56	45.62	68.20	-22.58	Peak	HORIZONTAL

Remark:

- 1 Field strength limits for frequency above 1000MHz are based on average limits. However, Peak mode field strength shall not exceed the average limits specified plus 20dB.
- 2 Measurement of data within this frequency range shown “ - ” in the table above means the reading of emissions are attenuated more than 20dB below the permissible limits or the field strength is too small to be measured.

Radiated Spurious Emission Measurement Result (above 1GHz)

Operation Mode	TX MODE	Test Date	2020/04/07
Channel Number	CH High	Test By	Barry
Temperature	25	Humidity	60 %

No	Freq MHz	Reading dBuV	Factor dB	Level dBuV/m	Limit dBuV/m	Margin dB	Remark	Pol V/H
1	1182.00	55.11	-19.90	35.21	74.00	-38.79	Peak	VERTICAL
2	4689.00	45.83	-9.56	36.27	74.00	-37.73	Peak	VERTICAL
3	11650.00	34.56	6.56	41.12	74.00	-32.88	Peak	VERTICAL
4	17475.00	35.07	13.64	48.71	68.20	-19.49	Peak	VERTICAL
1	1182.00	55.62	-19.90	35.72	74.00	-38.28	Peak	HORIZONTAL
2	4325.00	46.92	-10.89	36.03	74.00	-37.97	Peak	HORIZONTAL
3	11650.00	34.43	6.56	40.99	74.00	-33.01	Peak	HORIZONTAL
4	17475.00	34.84	13.64	48.48	68.20	-19.72	Peak	HORIZONTAL

Remark:

- 1 Field strength limits for frequency above 1000MHz are based on average limits. However, Peak mode field strength shall not exceed the average limits specified plus 20dB.
- 2 Measurement of data within this frequency range shown “ - ” in the table above means the reading of emissions are attenuated more than 20dB below the permissible limits or the field strength is too small to be measured.

**Radiated Spurious Emission Measurement Result (above 1GHz)
(Band UNII-3, 802.11n HT40 mode)**

Operation Mode	TX MODE	Test Date	2020/04/07
Channel Number	CH Low	Test By	Barry
Temperature	25	Humidity	60 %

No	Freq MHz	Reading dBuV	Factor dB	Level dBuV/m	Limit dBuV/m	Margin dB	Remark	Pol V/H
1	2400.00	49.49	-15.72	33.77	68.20	-34.43	Peak	VERTICAL
2	3660.00	48.58	-13.11	35.47	74.00	-38.53	Peak	VERTICAL
3	11510.00	34.03	6.53	40.56	74.00	-33.44	Peak	VERTICAL
4	17265.00	31.67	11.76	43.43	68.20	-24.77	Peak	VERTICAL
1	3044.00	48.33	-14.43	33.90	68.20	-34.30	Peak	HORIZONTAL
2	4360.00	46.03	-10.77	35.26	74.00	-38.74	Peak	HORIZONTAL
3	11510.00	34.89	6.53	41.42	74.00	-32.58	Peak	HORIZONTAL
4	17265.00	36.16	11.76	47.92	68.20	-20.28	Peak	HORIZONTAL

Remark:

- 1 Field strength limits for frequency above 1000MHz are based on average limits. However, Peak mode field strength shall not exceed the average limits specified plus 20dB.
- 2 Measurement of data within this frequency range shown “ - ” in the table above means the reading of emissions are attenuated more than 20dB below the permissible limits or the field strength is too small to be measured.

Radiated Spurious Emission Measurement Result (above 1GHz)

Operation Mode	TX MODE	Test Date	2020/04/07
Channel Number	CH High	Test By	Barry
Temperature	25	Humidity	60 %

No	Freq MHz	Reading dBuV	Factor dB	Level dBuV/m	Limit dBuV/m	Margin dB	Remark	Pol V/H
1	1602.00	53.84	-18.98	34.86	74.00	-39.14	Peak	VERTICAL
2	4479.00	46.48	-10.33	36.15	68.20	-32.05	Peak	VERTICAL
3	11590.00	35.18	6.55	41.73	74.00	-32.27	Peak	VERTICAL
4	17385.00	32.67	12.83	45.50	68.20	-22.70	Peak	VERTICAL
1	3177.00	48.99	-14.31	34.68	68.20	-33.52	Peak	HORIZONTAL
2	4115.00	47.65	-11.55	36.10	74.00	-37.90	Peak	HORIZONTAL
3	11590.00	35.11	6.55	41.66	74.00	-32.34	Peak	HORIZONTAL
4	17385.00	34.12	12.83	46.95	68.20	-21.25	Peak	HORIZONTAL

Remark:

- 1 Field strength limits for frequency above 1000MHz are based on average limits. However, Peak mode field strength shall not exceed the average limits specified plus 20dB.
- 2 Measurement of data within this frequency range shown “ - ” in the table above means the reading of emissions are attenuated more than 20dB below the permissible limits or the field strength is too small to be measured.

Radiated Spurious Emission Measurement Result (above 1GHz)

(Band UNII-3, 802.11ac VHT80 mode)

Operation Mode	TX MODE	Test Date	2020/04/07
Channel Number	CH Low	Test By	Barry
Temperature	25	Humidity	60 %

No	Freq MHz	Reading dBuV	Factor dB	Level dBuV/m	Limit dBuV/m	Margin dB	Remark	Pol V/H
1	1182.00	55.20	-19.90	35.30	74.00	-38.70	Peak	VERTICAL
2	3968.00	47.34	-12.05	35.29	74.00	-38.71	Peak	VERTICAL
3	11550.00	34.11	6.53	40.64	74.00	-33.36	Peak	VERTICAL
4	17325.00	33.58	12.30	45.88	68.20	-22.32	Peak	VERTICAL
1	3541.00	49.08	-13.48	35.60	68.20	-32.60	Peak	HORIZONTAL
2	4430.00	46.31	-10.52	35.79	68.20	-32.41	Peak	HORIZONTAL
3	11550.00	32.97	6.53	39.50	74.00	-34.50	Peak	HORIZONTAL
4	17325.00	32.05	12.30	44.35	68.20	-23.85	Peak	HORIZONTAL

Remark:

- 1 Field strength limits for frequency above 1000MHz are based on average limits. However, Peak mode field strength shall not exceed the average limits specified plus 20dB.
- 2 Measurement of data within this frequency range shown “ - ” in the table above means the reading of emissions are attenuated more than 20dB below the permissible limits or the field strength is too small to be measured.

Dipole Ant

Band Edges test (Band UNII-1 / Band UNII-2A, 802.11a mode) -Radiated

Operation Mode	TX CH Low	Test Date	2020/01/21
Channel Number	5180 MHz	Test By	Barry
Temperature	25	Humidity	65 %

No	Freq MHz	Reading dBuV	Factor dB	Level dBuV/m	Limit dBuV/m	Margin dB	Remark	Pol V/H
1	5150.00	54.20	-8.53	45.67	54.00	-8.33	Average	VERTICAL
2	5150.00	63.31	-8.53	54.78	74.00	-19.22	Peak	VERTICAL
3	5179.70	109.28	-8.46	100.82	F	--	Peak	VERTICAL
1	5150.00	58.90	-8.53	50.37	74.00	-23.63	Peak	HORIZONTAL
2	5181.80	102.00	-8.46	93.54	F	--	Peak	HORIZONTAL

Operation Mode	TX CH High	Test Date	2020/01/21
Channel Number	5320MHz	Test By	Barry
Temperature	25	Humidity	65 %

No	Freq MHz	Reading dBuV	Factor dB	Level dBuV/m	Limit dBuV/m	Margin dB	Remark	Pol V/H
1	5318.82	109.76	-8.17	101.59	F	--	Peak	VERTICAL
2	5350.00	56.54	-8.12	48.42	74.00	-25.58	Peak	VERTICAL
1	5317.84	103.53	-8.17	95.36	F	--	Peak	HORIZONTAL
2	5350.00	54.94	-8.12	46.82	74.00	-27.18	Peak	HORIZONTAL

Remark:

- 1 Measuring frequencies from the lowest internal frequency to the 10th of fundamental frequency
- 2 Field strength limits for frequency above 1000MHz are based on average limits. However, Peak mode field strength shall not exceed the average limits specified plus 20dB.
- 3 Measurement of data within this frequency range shown “ - ” in the table above means the reading of emissions are attenuated more than 20dB below the permissible limits or the field strength is too small to be measured.
- 4 Spectrum Peak mode IF bandwidth Setting : 1GHz- 40GHz, RBW= 1MHz, Sweep time= 200 ms., the VBW setting was 3 MHz.
- 5 Spectrum AV mode if bandwidth Setting : 1GHz- 40GHz, RBW= 1MHz, VBW= 1kHz, Sweep time= 200 ms.

Band Edges test (Band UNII-1 / Band UNII-2A, 802.11n HT20 mode) -Radiated

Operation Mode	TX CH Low	Test Date	2020/01/21
Channel Number	5180 MHz	Test By	Barry
Temperature	25	Humidity	65 %

No	Freq MHz	Reading dBuV	Factor dB	Level dBuV/m	Limit dBuV/m	Margin dB	Remark	Pol V/H
1	5150.00	61.95	-8.53	53.42	74.00	-20.58	Peak	VERTICAL
2	5181.10	108.35	-8.46	99.89	F	--	Peak	VERTICAL
1	5150.00	57.04	-8.53	48.51	74.00	-25.49	Peak	HORIZONTAL
2	5179.00	104.28	-8.46	95.82	F	--	Peak	HORIZONTAL

Operation Mode	TX CH High	Test Date	2020/01/21
Channel Number	5320MHz	Test By	Barry
Temperature	25	Humidity	65 %

No	Freq MHz	Reading dBuV	Factor dB	Level dBuV/m	Limit dBuV/m	Margin dB	Remark	Pol V/H
1	5319.50	107.63	-8.17	99.46	F	--	Peak	VERTICAL
2	5350.00	57.44	-8.12	49.32	74.00	-24.68	Peak	VERTICAL
1	5318.75	101.63	-8.17	93.46	F	-	Peak	HORIZONTAL
2	5350.00	55.15	-8.12	47.03	74.00	-26.97	Peak	HORIZONTAL

Remark:

- 1 Measuring frequencies from the lowest internal frequency to the 10th of fundamental frequency
- 2 Field strength limits for frequency above 1000MHz are based on average limits. However, Peak mode field strength shall not exceed the average limits specified plus 20dB.
- 3 Measurement of data within this frequency range shown “ - ” in the table above means the reading of emissions are attenuated more than 20dB below the permissible limits or the field strength is too small to be measured.
- 4 Spectrum Peak mode IF bandwidth Setting : 1GHz- 40GHz, RBW= 1MHz, Sweep time= 200 ms., the VBW setting was 3 MHz.
- 5 Spectrum AV mode if bandwidth Setting : 1GHz- 40GHz, RBW= 1MHz, VBW ≥ 1/Ton, Sweep time= 200 ms.

Band Edges test (Band UNII-1 / Band UNII-2A, 802.11n HT40 mode) -Radiated

Operation Mode	TX CH Low	Test Date	2020/01/21
Channel Number	5190 MHz	Test By	Barry
Temperature	25	Humidity	65 %

No	Freq MHz	Reading dBuV	Factor dB	Level dBuV/m	Limit dBuV/m	Margin dB	Remark	Pol V/H
1	5150.00	61.38	-8.53	52.85	74.00	-21.15	Peak	VERTICAL
2	5194.38	104.62	-8.43	96.19	F	--	Peak	VERTICAL
1	5150.00	56.39	-8.53	47.86	74.00	-26.14	Peak	HORIZONTAL
2	5185.86	97.49	-8.45	89.04	F	--	Peak	HORIZONTAL

Operation Mode	TX CH High	Test Date	2020/01/21
Channel Number	5310MHz	Test By	Barry
Temperature	25	Humidity	65 %

No	Freq MHz	Reading dBuV	Factor dB	Level dBuV/m	Limit dBuV/m	Margin dB	Remark	Pol V/H
1	5307.28	103.97	-8.20	95.77	F	--	Peak	VERTICAL
2	5350.00	54.63	-8.12	46.51	54.00	-7.49	Average	VERTICAL
3	5350.00	63.26	-8.12	55.14	74.00	-18.86	Peak	VERTICAL
4	5351.44	53.38	-8.11	45.27	54.00	-8.73	Average	VERTICAL
5	5351.44	67.60	-8.11	59.49	74.00	-14.51	Peak	VERTICAL
1	5311.44	97.11	-8.19	88.92	F	--	Peak	HORIZONTAL
2	5350.00	56.28	-8.12	48.16	74.00	-25.84	Peak	HORIZONTAL

Remark:

- 1 Measuring frequencies from the lowest internal frequency to the 10th of fundamental frequency
- 2 Field strength limits for frequency above 1000MHz are based on average limits. However, Peak mode field strength shall not exceed the average limits specified plus 20dB.
- 3 Measurement of data within this frequency range shown “ - ” in the table above means the reading of emissions are attenuated more than 20dB below the permissible limits or the field strength is too small to be measured.
- 4 Spectrum Peak mode IF bandwidth Setting : 1GHz- 40GHz, RBW= 1MHz, Sweep time= 200 ms., the VBW setting was 3 MHz.
- 5 Spectrum AV mode if bandwidth Setting : 1GHz- 40GHz, RBW= 1MHz, VBW ≥ 1/Ton, Sweep time= 200 ms.

Band Edges test (Band UNII-1 / Band UNII-2A, 802.11ac VHT80 mode) -Radiated

Operation Mode	TX CH Low	Test Date	2020/01/21
Channel Number	5210 MHz	Test By	Barry
Temperature	25	Humidity	65 %

No	Freq MHz	Reading dBuV	Factor dB	Level dBuV/m	Limit dBuV/m	Margin dB	Remark	Pol V/H
1	5140.50	57.92	-8.56	49.36	54.00	-4.64	Average	VERTICAL
2	5140.50	69.70	-8.56	61.14	74.00	-12.86	Peak	VERTICAL
3	5150.00	55.47	-8.53	46.94	54.00	-7.06	Average	VERTICAL
4	5150.00	68.11	-8.53	59.58	74.00	-14.42	Peak	VERTICAL
5	5208.00	101.72	-8.41	93.31	F	--	Peak	VERTICAL
1	5150.00	61.40	-8.53	52.87	74.00	-21.13	Peak	HORIZONTAL
2	5217.00	97.07	-8.38	88.69	F	--	Peak	HORIZONTAL

Operation Mode	TX CH High	Test Date	2020/01/21
Channel Number	5290MHz	Test By	Barry
Temperature	25	Humidity	65 %

No	Freq MHz	Reading dBuV	Factor dB	Level dBuV/m	Limit dBuV/m	Margin dB	Remark	Pol V/H
1	5291.40	101.95	-8.22	93.73	F	--	Peak	VERTICAL
2	5350.00	68.26	-8.12	60.14	74.00	-13.86	Peak	VERTICAL
3	5350.80	52.56	-8.11	44.45	54.00	-9.55	Average	VERTICAL
4	5350.80	69.59	-8.11	61.48	74.00	-12.52	Peak	VERTICAL
5	5356.40	51.68	-8.10	43.58	54.00	-10.42	Average	VERTICAL
6	5356.40	68.74	-8.10	60.64	74.00	-13.36	Peak	VERTICAL
1	5291.80	94.72	-8.22	86.50	F	--	Peak	HORIZONTAL
2	5350.00	56.72	-8.12	48.60	74.00	-25.40	Peak	HORIZONTAL

Remark:

- 1 Measuring frequencies from the lowest internal frequency to the 10th of fundamental frequency
- 2 Field strength limits for frequency above 1000MHz are based on average limits. However, Peak mode field strength shall not exceed the average limits specified plus 20dB.
- 3 Measurement of data within this frequency range shown “ - ” in the table above means the reading of emissions are attenuated more than 20dB below the permissible limits or the field strength is too small to be measured.
- 4 Spectrum Peak mode IF bandwidth Setting : 1GHz- 40GHz, RBW= 1MHz, Sweep time= 200 ms., the VBW setting was 3 MHz.
- 5 Spectrum AV mode if bandwidth Setting : 1GHz- 40GHz, RBW= 1MHz, VBW ≥ 1/Ton, Sweep time= 200 ms.

Band Edges test (Band UNII-2C, 802.11a mode) -Radiated

Operation Mode	TX CH Low	Test Date	2020/01/21
Channel Number	5500 MHz	Test By	Barry
Temperature	25	Humidity	65 %

No	Freq MHz	Reading dBuV	Factor dB	Level dBuV/m	Limit dBuV/m	Margin dB	Remark	Pol V/H
1	5470.00	59.64	-7.79	51.85	68.20	-16.35	Peak	VERTICAL
2	5499.11	108.80	-7.70	101.10	F	--	Peak	VERTICAL
1	5470.00	56.19	-7.79	48.40	68.20	-19.80	Peak	HORIZONTAL
2	5498.78	103.68	-7.70	95.98	F	--	Peak	HORIZONTAL

Operation Mode	TX CH High	Test Date	2020/01/21
Channel Number	5700MHz	Test By	Barry
Temperature	25	Humidity	65 %

No	Freq MHz	Reading dBuV	Factor dB	Level dBuV/m	Limit dBuV/m	Margin dB	Remark	Pol V/H
1	5699.28	106.16	-7.03	99.13	F	--	Peak	VERTICAL
2	5725.00	65.47	-6.95	58.52	68.20	-9.68	Peak	VERTICAL
1	5698.00	104.41	-7.03	97.38	F	--	Peak	HORIZONTAL
2	5725.00	61.47	-6.95	54.52	68.20	-13.68	Peak	HORIZONTAL

Remark:

- 1 Measuring frequencies from the lowest internal frequency to the 10th of fundamental frequency
- 2 Field strength limits for frequency above 1000MHz are based on average limits. However, Peak mode field strength shall not exceed the average limits specified plus 20dB.
- 3 Measurement of data within this frequency range shown “ - ” in the table above means the reading of emissions are attenuated more than 20dB below the permissible limits or the field strength is too small to be measured.
- 4 Spectrum Peak mode IF bandwidth Setting : 1GHz- 40GHz, RBW= 1MHz, Sweep time= 200 ms., the VBW setting was 3 MHz.
- 5 Spectrum AV mode if bandwidth Setting : 1GHz- 40GHz, RBW= 1MHz, VBW= 1kHz, Sweep time= 200 ms.

Band Edges test (Band UNII-2C, 802.11n HT20 mode) -Radiated

Operation Mode	TX CH Low	Test Date	2020/01/21
Channel Number	5500 MHz	Test By	Barry
Temperature	25	Humidity	65 %

No	Freq MHz	Reading dBuV	Factor dB	Level dBuV/m	Limit dBuV/m	Margin dB	Remark	Pol V/H
1	5467.21	64.40	-7.80	56.60	68.20	-11.60	Peak	VERTICAL
2	5470.00	60.71	-7.79	52.92	68.20	-15.28	Peak	VERTICAL
3	5497.46	108.49	-7.70	100.79	F	--	Peak	VERTICAL
1	5470.00	55.11	-7.79	47.32	68.20	-20.88	Peak	HORIZONTAL
2	5500.98	102.07	-7.70	94.37	F	--	Peak	HORIZONTAL

Operation Mode	TX CH High	Test Date	2020/01/21
Channel Number	5700MHz	Test By	Barry
Temperature	25	Humidity	65 %

No	Freq MHz	Reading dBuV	Factor dB	Level dBuV/m	Limit dBuV/m	Margin dB	Remark	Pol V/H
1	5698.00	106.40	-7.03	99.37	F	--	Peak	VERTICAL
2	5725.00	68.13	-6.95	61.18	68.20	-7.02	Peak	VERTICAL
1	5701.04	104.15	-7.03	97.12	F	--	Peak	HORIZONTAL
2	5725.00	62.48	-6.95	55.53	68.20	-12.67	Peak	HORIZONTAL

Remark:

- 1 Measuring frequencies from the lowest internal frequency to the 10th of fundamental frequency
- 2 Field strength limits for frequency above 1000MHz are based on average limits. However, Peak mode field strength shall not exceed the average limits specified plus 20dB.
- 3 Measurement of data within this frequency range shown “ - ” in the table above means the reading of emissions are attenuated more than 20dB below the permissible limits or the field strength is too small to be measured.
- 4 Spectrum Peak mode IF bandwidth Setting : 1GHz- 40GHz, RBW= 1MHz, Sweep time= 200 ms., the VBW setting was 3 MHz.
- 5 Spectrum AV mode if bandwidth Setting : 1GHz- 40GHz, RBW= 1MHz, VBW ≥ 1/Ton, Sweep time= 200 ms.

Band Edges test (Band UNII-2C, 802.11n HT40 mode) -Radiated

Operation Mode	TX CH Low	Test Date	2020/04/07
Channel Number	5510 MHz	Test By	Barry
Temperature	25	Humidity	65 %

No	Freq MHz	Reading dBuV	Factor dB	Level dBuV/m	Limit dBuV/m	Margin dB	Remark	Pol V/H
1	5470.00	65.64	-7.79	57.85	68.20	-10.35	Peak	VERTICAL
2	5511.60	104.50	-7.66	96.84	F	--	Peak	VERTICAL
1	5470.00	58.48	-7.79	50.69	68.20	-17.51	Peak	HORIZONTAL
2	5505.45	99.24	-7.69	91.55	F	--	Peak	HORIZONTAL

Operation Mode	TX CH High	Test Date	2020/04/07
Channel Number	5670MHz	Test By	Barry
Temperature	25	Humidity	65 %

No	Freq MHz	Reading dBuV	Factor dB	Level dBuV/m	Limit dBuV/m	Margin dB	Remark	Pol V/H
1	5672.00	103.71	-7.13	96.58	F	--	Peak	VERTICAL
2	5725.00	56.40	-6.95	49.45	68.20	-18.75	Peak	VERTICAL
1	5672.20	101.90	-7.13	94.77	F	--	Peak	HORIZONTAL
2	5725.00	56.89	-6.95	49.94	68.20	-18.26	Peak	HORIZONTAL

Remark:

- 1 Measuring frequencies from the lowest internal frequency to the 10th of fundamental frequency
- 2 Field strength limits for frequency above 1000MHz are based on average limits. However, Peak mode field strength shall not exceed the average limits specified plus 20dB.
- 3 Measurement of data within this frequency range shown “ - ” in the table above means the reading of emissions are attenuated more than 20dB below the permissible limits or the field strength is too small to be measured.
- 4 Spectrum Peak mode IF bandwidth Setting : 1GHz- 40GHz, RBW= 1MHz, Sweep time= 200 ms., the VBW setting was 3 MHz.
- 5 Spectrum AV mode if bandwidth Setting : 1GHz- 40GHz, RBW= 1MHz, VBW ≥ 1/Ton, Sweep time= 200 ms.

Band Edges test (Band UNII-2C, 802.11ac VHT80 mode) -Radiated

Operation Mode	TX CH Low	Test Date	2020/04/07
Channel Number	5530 MHz	Test By	Barry
Temperature	25	Humidity	65 %

No	Freq MHz	Reading dBuV	Factor dB	Level dBuV/m	Limit dBuV/m	Margin dB	Remark	Pol V/H
1	5435.70	48.92	-7.90	41.02	54.00	-12.98	Average	VERTICAL
2	5435.70	66.12	-7.90	58.22	74.00	-15.78	Peak	VERTICAL
3	5456.78	54.21	-7.68	46.53	54.00	-7.47	Average	VERTICAL
4	5456.78	66.61	-7.68	58.93	74.00	-15.07	Peak	VERTICAL
5	5470.00	69.97	-7.79	62.18	68.20	-6.02	Peak	VERTICAL
6	5532.43	100.82	-7.60	93.22	F	--	Peak	VERTICAL
1	5470.00	61.28	-7.79	53.49	68.20	-14.71	Peak	HORIZONTAL
2	5521.72	96.23	-7.63	88.60	F	--	Peak	HORIZONTAL

Operation Mode	TX CH High	Test Date	2020/04/07
Channel Number	5610MHz	Test By	Barry
Temperature	25	Humidity	65 %

No	Freq MHz	Reading dBuV	Factor dB	Level dBuV/m	Limit dBuV/m	Margin dB	Remark	Pol V/H
1	5608.08	102.02	-7.35	94.67	F	--	Peak	VERTICAL
2	5725.00	55.34	-6.95	48.39	68.20	-19.81	Peak	VERTICAL
1	5613.12	100.12	-7.35	92.77	F	--	Peak	HORIZONTAL
2	5725.00	55.34	-6.95	48.39	68.20	-19.81	Peak	HORIZONTAL

Remark:

- Measuring frequencies from the lowest internal frequency to the 10th of fundamental frequency
- Field strength limits for frequency above 1000MHz are based on average limits. However, Peak mode field strength shall not exceed the average limits specified plus 20dB.
- Measurement of data within this frequency range shown “ - ” in the table above means the reading of emissions are attenuated more than 20dB below the permissible limits or the field strength is too small to be measured.
- Spectrum Peak mode IF bandwidth Setting : 1GHz- 40GHz, RBW= 1MHz, Sweep time= 200 ms., the VBW setting was 3 MHz.
- Spectrum AV mode if bandwidth Setting : 1GHz- 40GHz, RBW= 1MHz, VBW= 2kHz, Sweep time= 200 ms.

Band Edges test (Band UNII-3, 802.11a mode) –Radiated

Operation Mode TX CH Low
 Channel Number 5745 MHz
 Temperature 25

Test Date 2020/01/21
 Test By Barry
 Humidity 65 %

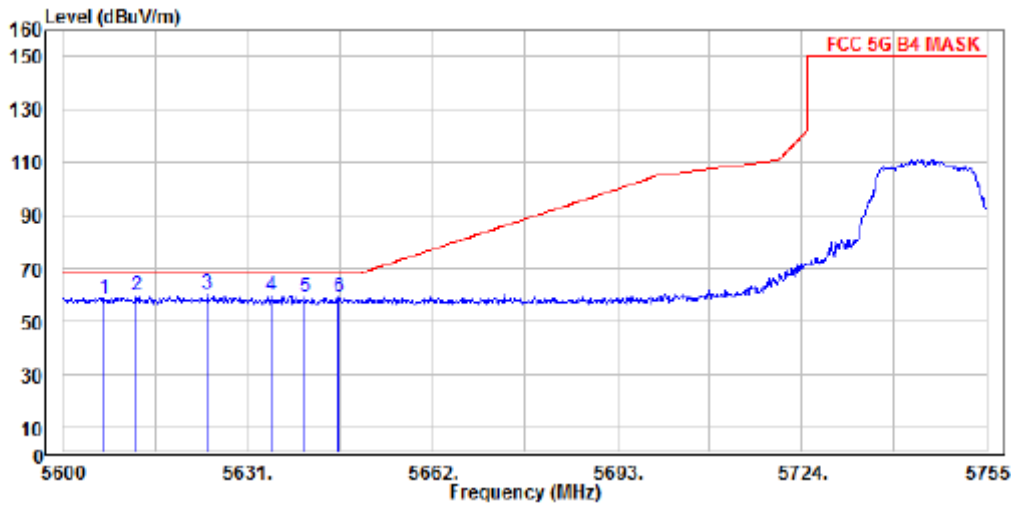

Condition: FCC 5G B4 MASK 3m factor\966 9128D V 1-18G.csv Vertical
 : RBW:1000kHz VBW:1000kHz SWT:Auto DET:Positive
 Mode : 5GHz Band 4 a low ch
 Note :

	Read Freq	Read Level	Factor	Level	Limit	Over	
	MHz	dBuV	dB/m	dBuV/m	dBuV/m	dB	
1	5606.975	55.13	3.40	58.53	68.20	-9.67	Vertical
2	5612.245	55.96	3.42	59.38	68.20	-8.82	Vertical
3 PP	5624.180	57.05	3.46	60.51	68.20	-7.69	Vertical
4	5634.875	56.41	3.48	59.89	68.20	-8.31	Vertical
5	5640.610	55.38	3.50	58.88	68.20	-9.32	Vertical
6	5646.345	55.28	3.51	58.79	68.20	-9.41	Vertical

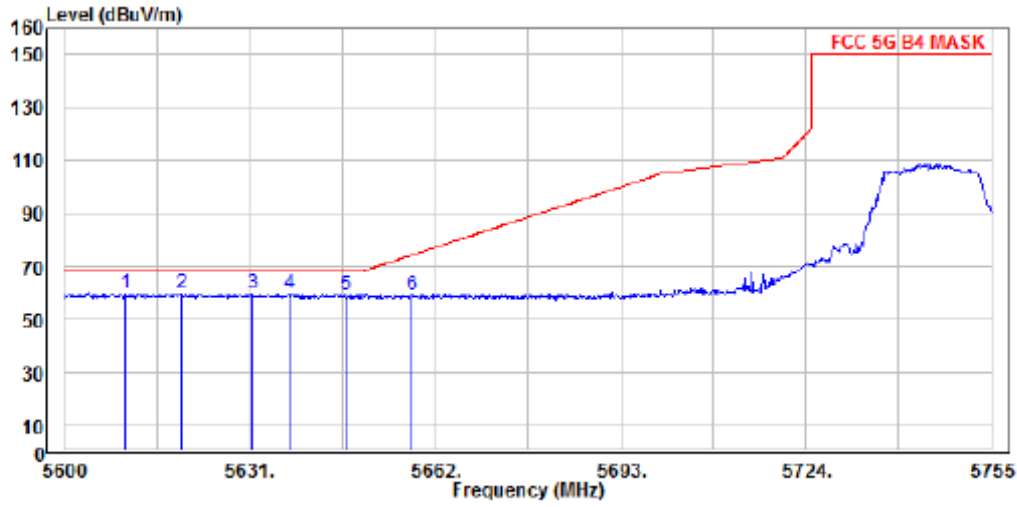

Condition: FCC 5G B4 MASK 3m factor\966 9120D H 1-18G.csv Horizontal
 : RBW:1000kHz VBN:1000kHz SWT:Auto DET:Positive
 Mode : 5GHz Band 4 a low ch
 Note :

	Read		Limit	Over		
Freq	Level	Factor	Level	Line	Limit	Pol/Phase
MHz	dBuV	dB/m	dBuV/m	dBuV/m	dB	
1	5610.075	55.99	3.42	59.41	68.20	-8.79 Horizontal
2	5619.530	55.90	3.44	59.34	68.20	-8.86 Horizontal
3	5631.465	56.07	3.47	59.54	68.20	-8.66 Horizontal
4 PP	5637.665	56.15	3.49	59.64	68.20	-8.56 Horizontal
5	5647.120	55.79	3.51	59.30	68.20	-8.90 Horizontal
6	5658.125	55.63	3.54	59.17	74.23	-15.06 Horizontal

Operation Mode TX CH High
 Channel Number 5825MHz
 Temperature 25

Test Date 2020/01/21
 Test By Barry
 Humidity 65 %

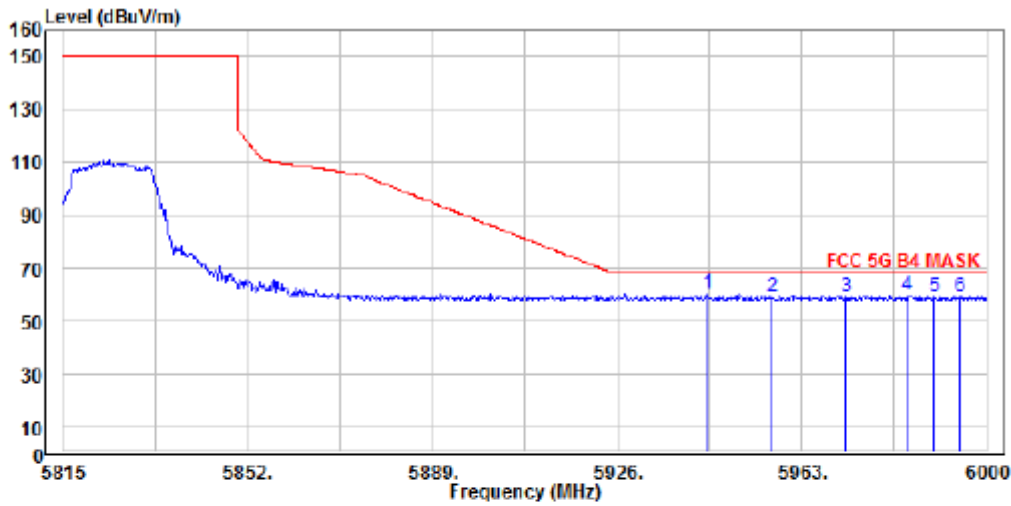

Condition: FCC 5G B4 MASK 3m factor\966 9120D V 1-18G.csv Vertical
 : RBW:1000kHz VBW:1000kHz SWT:Auto DET:Positive
 Mode : 5GHz Band 4 a high ch
 Note :

	Read Freq	Read Level	Factor	Limit Level	Over Limit	Pol/Phase
	MHz	dBuV	dB/m	dBuV/m	dBuV/m	dB
1 PP	5944.130	55.67	4.27	59.94	68.20	-8.26 Vertical
2	5957.080	54.83	4.31	59.14	68.20	-9.06 Vertical
3	5971.880	54.84	4.35	59.19	68.20	-9.01 Vertical
4	5984.090	55.04	4.38	59.42	68.20	-8.78 Vertical
5	5989.455	54.61	4.39	59.00	68.20	-9.20 Vertical
6	5994.820	54.90	4.41	59.31	68.20	-8.89 Vertical

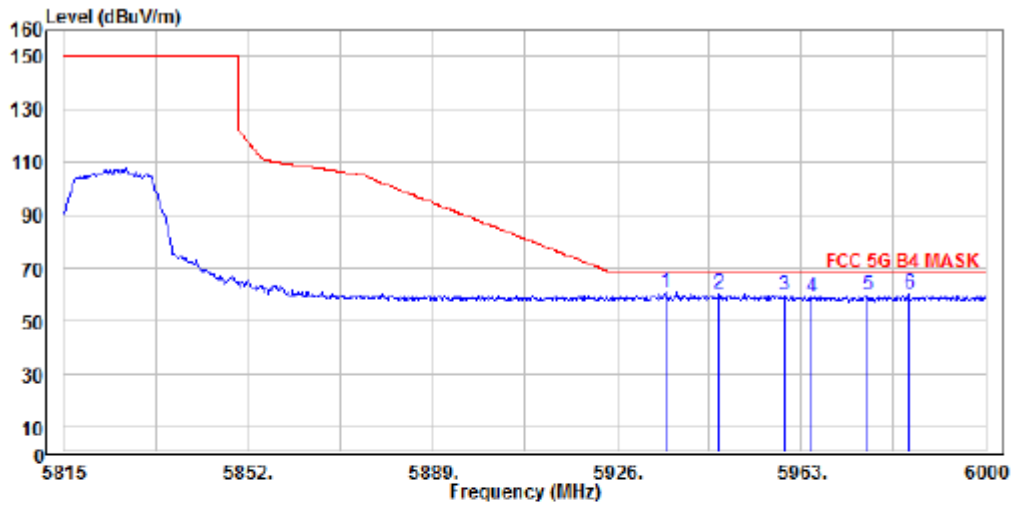

Condition: FCC 5G B4 MASK 3m factor\966 9120D H 1-18G.csv Horizontal
 : RBW:1000kHz VBW:1000kHz SWT:Auto DET:Positive
 Mode : 5GHz Band 4 a high ch
 Note :

	Read		Limit	Over		
Freq	Level	Factor	Level	Line	Limit	Pol/Phase
MHz	dBuV	dB/m	dBuV/m	dBuV/m	dB	
1 PP 5935.805	56.66	4.26	60.92	68.20	-7.28	Horizontal
2 5946.535	55.95	4.28	60.23	68.20	-7.97	Horizontal
3 5959.670	55.02	4.31	59.33	68.20	-8.87	Horizontal
4 5965.035	54.85	4.33	59.18	68.20	-9.02	Horizontal
5 5976.505	55.09	4.36	59.45	68.20	-8.75	Horizontal
6 5984.645	55.78	4.38	60.16	68.20	-8.04	Horizontal

Band Edges test (Band UNII-3, 802.11n HT20 mode) –Radiated

Operation Mode TX CH Low
 Channel Number 5745 MHz
 Temperature 25

Test Date 2020/01/21
 Test By Barry
 Humidity 65 %

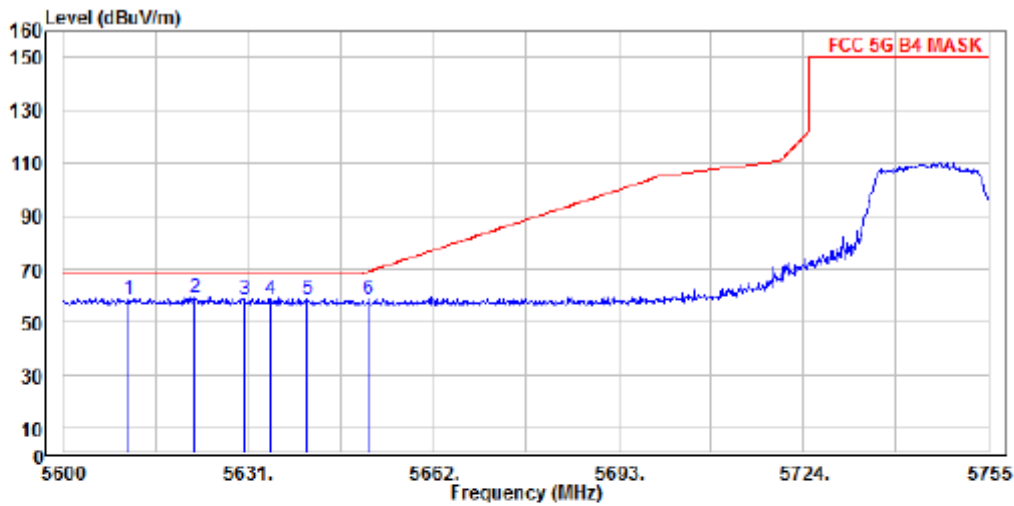

Condition: FCC 5G B4 MASK 3m factor\966 9120D V 1-18G.csv Vertical
 : RBW:1000kHz VBW:1000kHz SWT:Auto DET:Positive
 Mode : 5GHz Band 4 n20 low ch
 Note :

	Read Freq	Read Level	Factor	Level	Limit	Over	
	MHz	dBuV	dB/m	dBuV/m	dBuV/m	dB	
1	5611.005	55.11	3.42	58.53	68.20	-9.67	Vertical
2 PP	5621.855	55.43	3.45	58.88	68.20	-9.32	Vertical
3	5630.225	55.15	3.47	58.62	68.20	-9.58	Vertical
4	5634.720	55.16	3.48	58.64	68.20	-9.56	Vertical
5	5640.765	54.87	3.50	58.37	68.20	-9.83	Vertical
6	5651.150	54.81	3.53	58.34	69.05	-10.71	Vertical

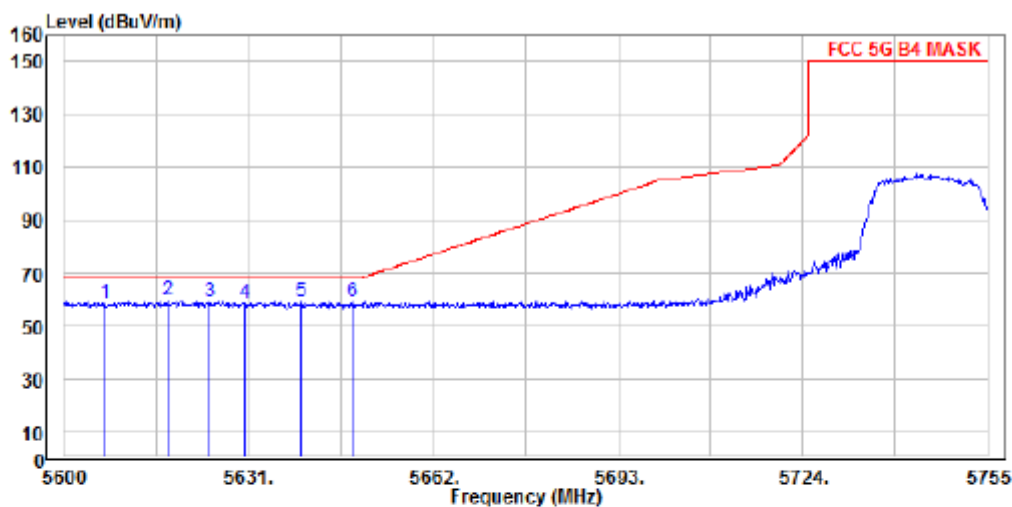

Condition: FCC 5G B4 MASK 3m factor\966 9120D H 1-18G.csv Horizontal
 : RBW:1000kHz VBW:1000kHz SWT:Auto DET:Positive
 Mode : 5GHz Band 4 n20 low ch
 Note :

	Read Freq	Read Level	Factor	Level	Limit	Over	
	MHz	dBuV	dB/m	dBuV/m	dBuV/m	dB	Pol/Phase
1	5606.820	55.12	3.40	58.52	68.20	-9.68	Horizontal
2	5617.360	56.29	3.43	59.72	68.20	-8.48	Horizontal
3	5624.335	55.67	3.46	59.13	68.20	-9.07	Horizontal
4	5630.225	54.98	3.47	58.45	68.20	-9.75	Horizontal
5	5639.835	55.76	3.50	59.26	68.20	-8.94	Horizontal
6	5648.515	55.40	3.51	58.91	68.20	-9.29	Horizontal

Operation Mode TX CH High
 Channel Number 5825 MHz
 Temperature 25

Test Date 2020/01/21
 Test By Barry
 Humidity 65 %

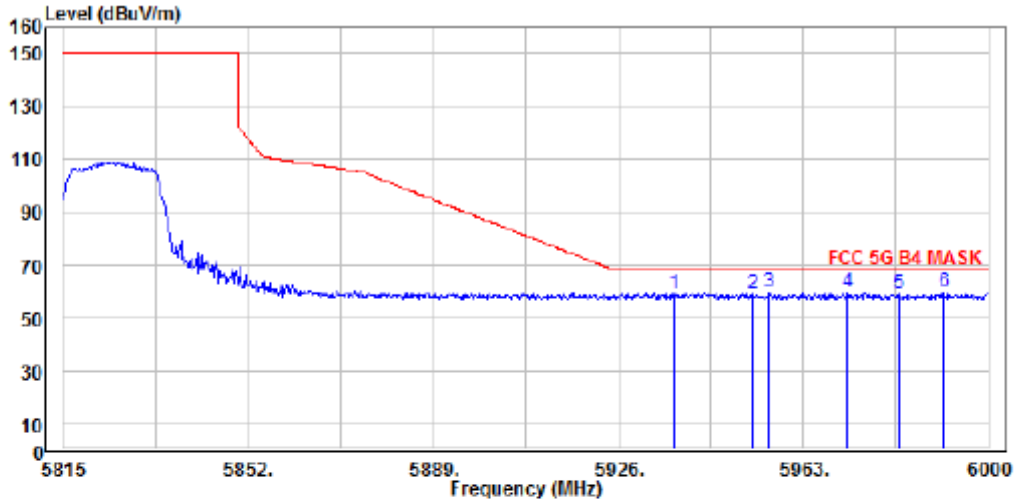

Condition: FCC 5G B4 MASK 3m factor\966 9120D V 1-18G.csv Vertical
 : RBW:1000kHz VBW:1000kHz SWT:Auto DET:Positive
 Mode : 5GHz Band 4 n20 high ch
 Note :

	Read		Limit	Over			
Freq	Level	Factor	Level	Line	Limit	Pol/Phase	
MHz	dBuV	dB/m	dBuV/m	dBuV/m	dB		
1	5937.100	54.96	4.26	59.22	68.20	-8.98	Vertical
2	5952.825	54.68	4.30	58.98	68.20	-9.22	Vertical
3	PP 5956.155	55.23	4.31	59.54	68.20	-8.66	Vertical
4	5971.880	55.12	4.35	59.47	68.20	-8.73	Vertical
5	5982.240	54.44	4.38	58.82	68.20	-9.38	Vertical
6	5991.120	54.98	4.39	59.37	68.20	-8.83	Vertical

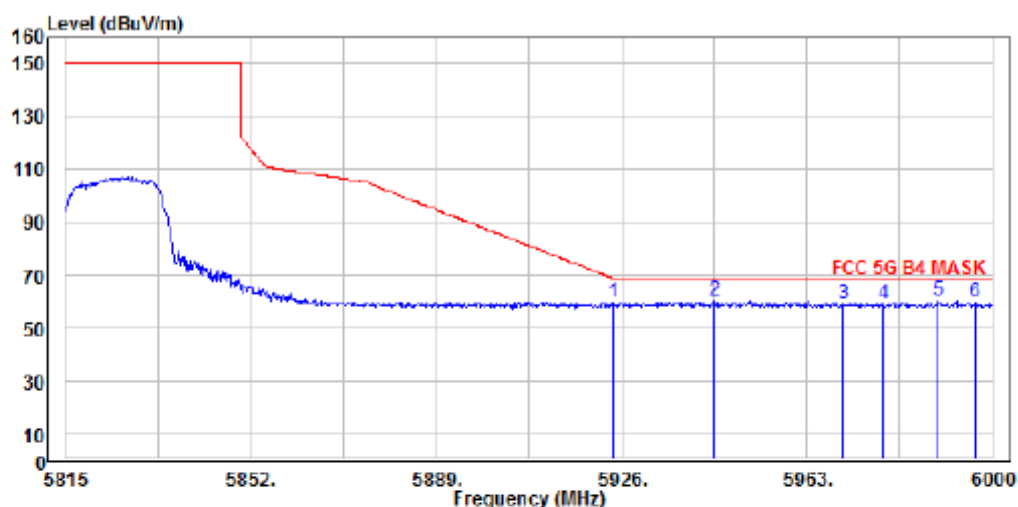

Condition: FCC 5G B4 MASK 3m factor\966 9120D H 1-18G.csv Horizontal
 : RBW:1000kHz VBN:1000kHz SWT:Auto DET:Positive
 Mode : 5GHz Band 4 n20 high ch
 Note :

	Read		Limit	Over		
Freq	Level	Factor	Level	Line	Limit	Pol/Phase
MHz	dBuV	dB/m	dBuV/m	dBuV/m	dB	
1	5924.335	55.15	4.23	59.38	68.69	-9.31 Horizontal
2	5944.500	55.75	4.27	60.02	68.20	-8.18 Horizontal
3	5970.215	54.92	4.34	59.26	68.20	-8.94 Horizontal
4	5978.355	54.60	4.36	58.96	68.20	-9.24 Horizontal
5 PP	5989.085	56.04	4.39	60.43	68.20	-7.77 Horizontal
6	5996.670	55.47	4.41	59.88	68.20	-8.32 Horizontal

Band Edges test (Band UNII-3, 802.11n HT40 mode) –Radiated

Operation Mode TX CH Low
 Channel Number 5755 MHz
 Temperature 25

Test Date 2020/01/21
 Test By Barry
 Humidity 65 %

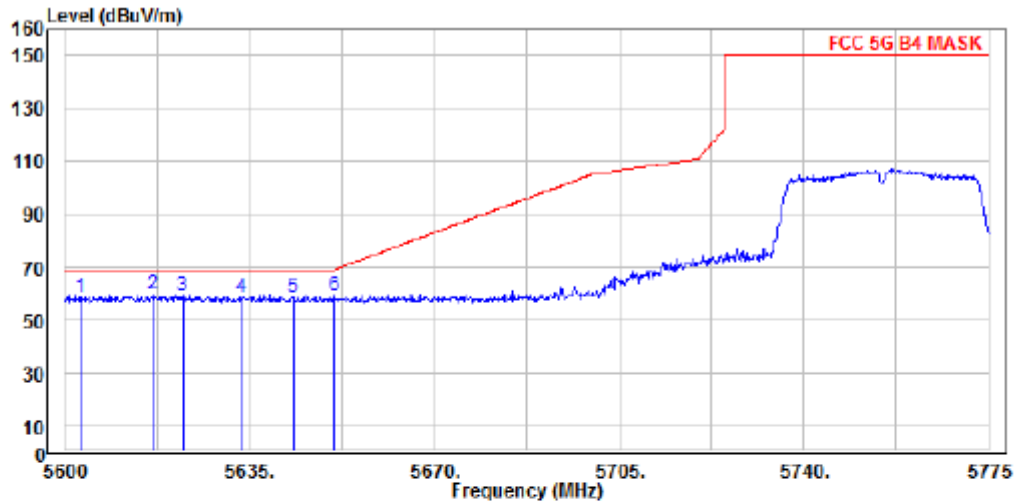

Condition: FCC 5G B4 MASK 3m factor\966 9120D V 1-18G.csv Vertical
 : RBW:1000kHz VBW:1000kHz SWT:Auto DET:Positive
 Mode : 5GHz Band 4 n40 low ch
 Note :

	Read Freq	Read Level	Read Factor	Limit Level	Limit Line	Over Limit	Pol/Phase
	MHz	dBuV	dB/m	dBuV/m	dBuV/m	dB	
1	5602.975	55.03	3.40	58.43	68.20	-9.77	Vertical
2 PP	5616.625	55.96	3.43	59.39	68.20	-8.81	Vertical
3	5622.225	55.50	3.45	58.95	68.20	-9.25	Vertical
4	5633.250	55.00	3.47	58.47	68.20	-9.73	Vertical
5	5643.225	55.16	3.50	58.66	68.20	-9.54	Vertical
6	5651.100	55.22	3.53	58.75	69.02	-10.27	Vertical

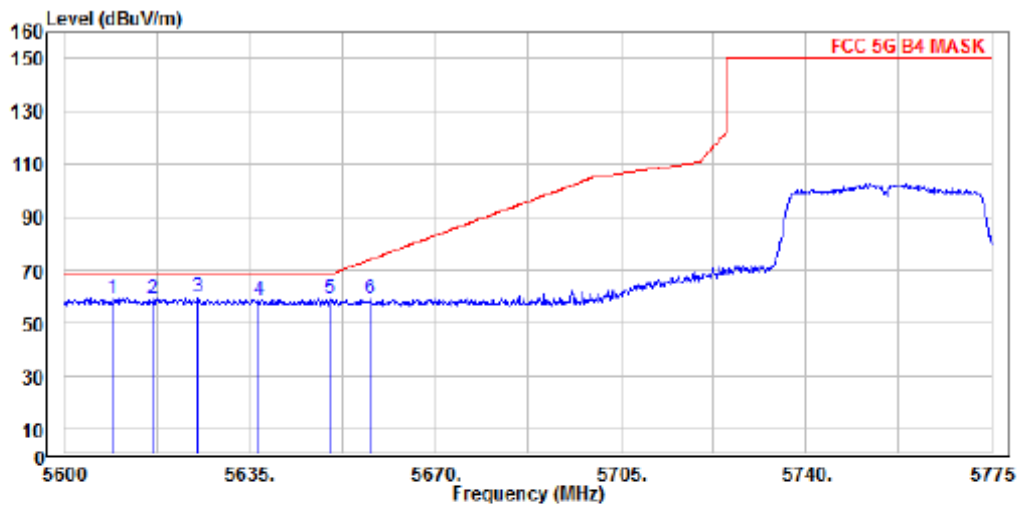

Condition: FCC 5G B4 MASK 3m factor\966 9120D H 1-18G.csv Horizontal
 : RBW:1000kHz VBW:1000kHz SWT:Auto DET:Positive
 Mode : 5GHz Band 4 n40 low ch
 Note :

	Read Freq	Read Level	Read Factor	Read Level	Limit Line	Over Limit	Pol/Phase
	MHz	dBuV	dB/m	dBuV/m	dBuV/m	dB	
1	5608.925	55.89	3.42	59.31	68.20	-8.89	Horizontal
2	5616.625	55.62	3.43	59.05	68.20	-9.15	Horizontal
3 PP	5625.200	56.15	3.46	59.61	68.20	-8.59	Horizontal
4	5636.575	55.01	3.49	58.50	68.20	-9.70	Horizontal
5	5650.225	55.48	3.53	59.01	68.37	-9.36	Horizontal
6	5657.750	55.26	3.54	58.80	73.96	-15.16	Horizontal

Operation Mode TX CH High
 Channel Number 5795MHz
 Temperature 25

Test Date 2020/01/21
 Test By Barry
 Humidity 65 %

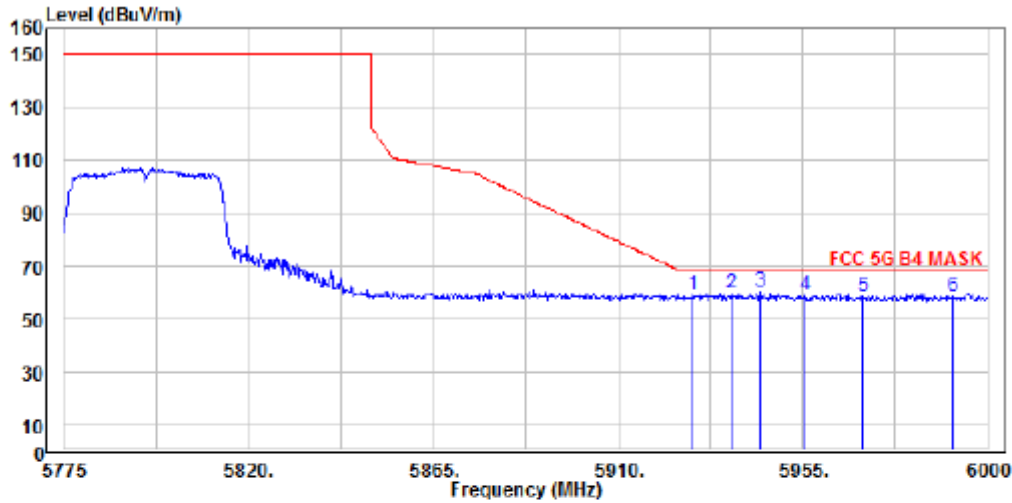

Condition: FCC 5G B4 MASK 3m factor\966 9120D V 1-18G.csv Vertical
 : RBW:1000kHz VBW:1000kHz SWT:Auto DET:Positive
 Mode : 5GHz Band 4 n40 high ch
 Note :

	Read		Limit	Over		
Freq	Level	Factor	Level	Line	Limit	Pol/Phase
MHz	dBuV	dB/m	dBuV/m	dBuV/m	dB	
1	5928.225	55.02	4.23	59.25	68.20	-8.95 Vertical
2	5937.675	55.08	4.26	59.34	68.20	-8.86 Vertical
3 PP	5944.650	56.18	4.27	60.45	68.20	-7.75 Vertical
4	5955.675	54.42	4.31	58.73	68.20	-9.47 Vertical
5	5969.625	54.16	4.34	58.50	68.20	-9.70 Vertical
6	5991.675	54.12	4.39	58.51	68.20	-9.69 Vertical

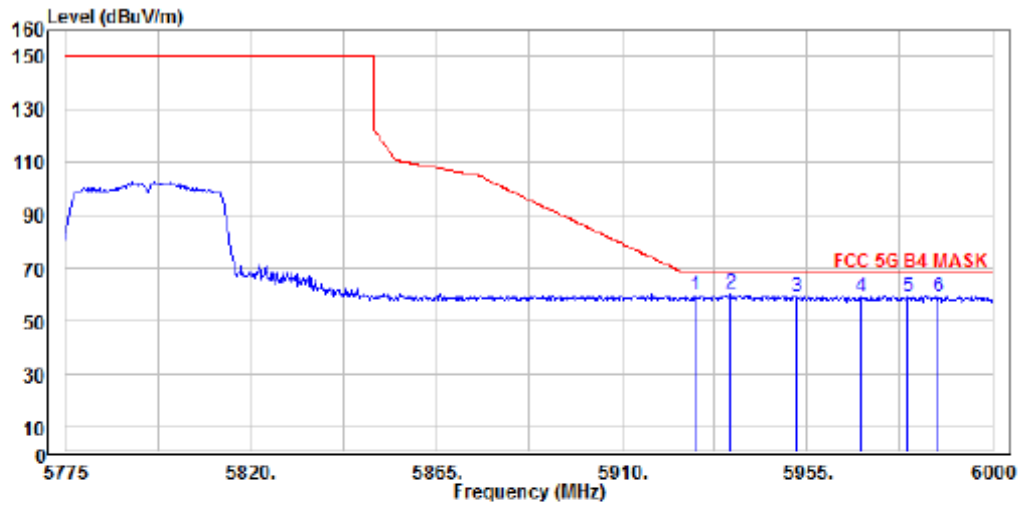

Condition: FCC 5G B4 MASK 3m factor\966 9120D H 1-18G.csv Horizontal
 : RBW:1000kHz VBW:1000kHz SWT:Auto DET:Positive
 Mode : 5GHz Band 4 n40 high ch
 Note :

	Read		Limit	Over		
Freq	Level	Factor	Level	Line	Limit	Pol/Phase
MHz	dBuV	dB/m	dBuV/m	dBuV/m	dB	
1	5927.775	55.46	4.23	59.69	68.20	-8.51 Horizontal
2	PP 5936.550	55.78	4.26	60.04	68.20	-8.16 Horizontal
3	5952.525	54.88	4.30	59.18	68.20	-9.02 Horizontal
4	5968.275	54.69	4.34	59.03	68.20	-9.17 Horizontal
5	5979.300	54.90	4.37	59.27	68.20	-8.93 Horizontal
6	5986.725	54.63	4.38	59.01	68.20	-9.19 Horizontal

Band Edges test (Band UNII-3, 802.11ac VHT80 mode) –Radiated

Operation Mode	TX CH Low	Test Date	2020/01/21
Channel Number	5775 MHz	Test By	Barry
Temperature	25	Humidity	65 %

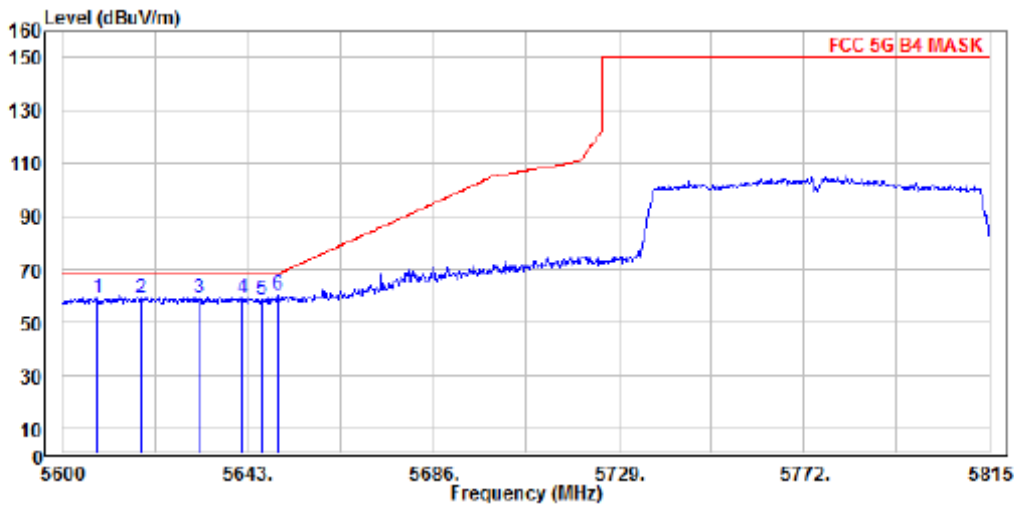

Condition: FCC 5G B4 MASK 3m factor\966 9128D V 1-18G.csv Vertical
 : RBW:1000kHz VBW:1000kHz SWT:Auto DET:Positive
 Mode : 5GHz Band 4 ac80 low ch
 Note :

	Read Freq	Read Level	Factor	Level	Limit	Over	
	MHz	dBuV	dB/m	dBuV/m	dBuV/m	dB	
1	5608.170	55.45	3.42	58.87	68.20	-9.33	Vertical
2	5618.060	55.82	3.43	59.25	68.20	-8.95	Vertical
3	5631.605	55.75	3.47	59.22	68.20	-8.98	Vertical
4	5641.710	55.53	3.50	59.03	68.20	-9.17	Vertical
5	5646.010	55.20	3.51	58.71	68.20	-9.49	Vertical
6 PP	5650.095	56.97	3.53	60.50	68.27	-7.77	Vertical

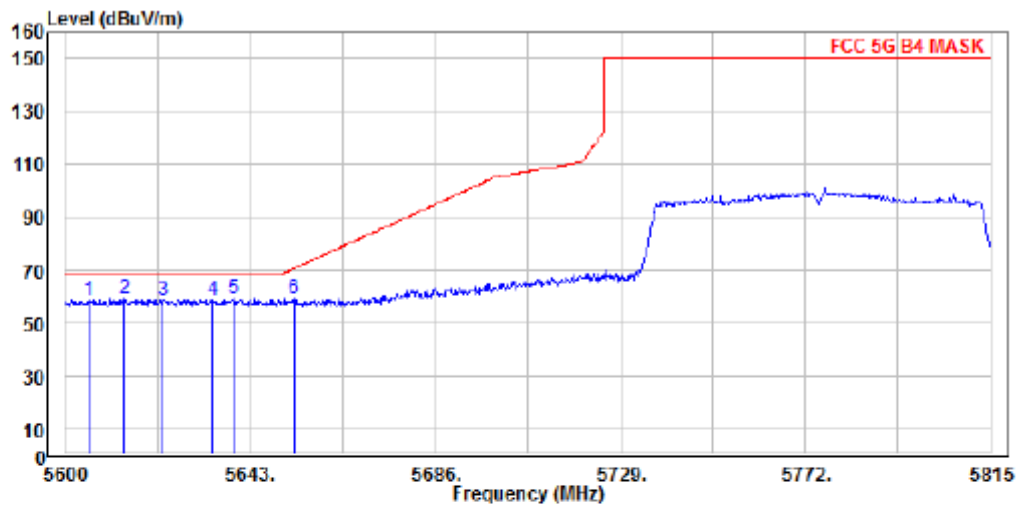

Condition: FCC 5G B4 MASK 3m factor\966 9120D H 1-18G.csv Horizontal
 : RBW:1000kHz VBW:1000kHz SWT:Auto DET:Positive
 Mode : 5GHz Band 4 ac80 low ch
 Note :

	Read		Limit	Over			
	Freq	Level	Factor	Level	Line	Limit	Pol/Phase
	MHz	dBuV	dB/m	dBuV/m	dBuV/m	dB	
1	5605.375	55.05	3.40	58.45	68.20	-9.75	Horizontal
2	5613.760	55.42	3.43	58.85	68.20	-9.35	Horizontal
3	5622.790	55.08	3.45	58.53	68.20	-9.67	Horizontal
4	5634.400	54.97	3.48	58.45	68.20	-9.75	Horizontal
5	5638.915	55.23	3.49	58.72	68.20	-9.48	Horizontal
6	5653.105	55.53	3.53	59.06	70.51	-11.45	Horizontal

Operation Mode TX CH High
 Channel Number 5775MHz
 Temperature 25

Test Date 2020/01/21
 Test By Barry
 Humidity 65 %

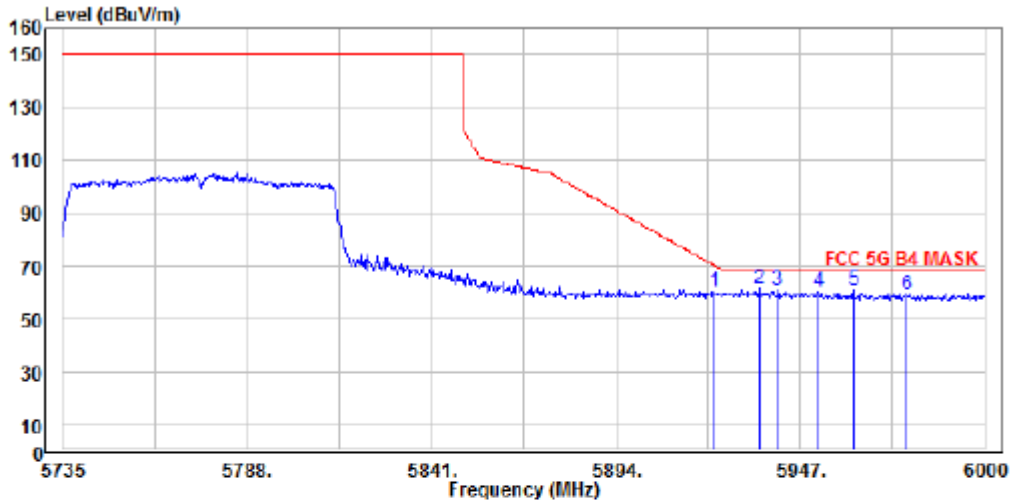

Condition: FCC 5G B4 MASK 3m factor\966 9120D V 1-18G.csv Vertical
 : RBW:1000kHz VBN:1000kHz SWT:Auto DET:Positive
 Mode : 5GHz Band 4 ac80 high ch
 Note :

	Read Freq	Read Level	Factor	Level	Limit	Over	
	MHz	dBuV	dB/m	dBuV/m	dBuV/m	dB	Pol/Phase
1	5922.355	56.23	4.22	60.45	70.15	-9.70	Vertical
2 PP	5935.075	57.34	4.25	61.59	68.20	-6.61	Vertical
3	5940.375	56.56	4.27	60.83	68.20	-7.37	Vertical
4	5952.300	56.13	4.30	60.43	68.20	-7.77	Vertical
5	5962.370	56.47	4.32	60.79	68.20	-7.41	Vertical
6	5977.475	54.78	4.36	59.14	68.20	-9.06	Vertical

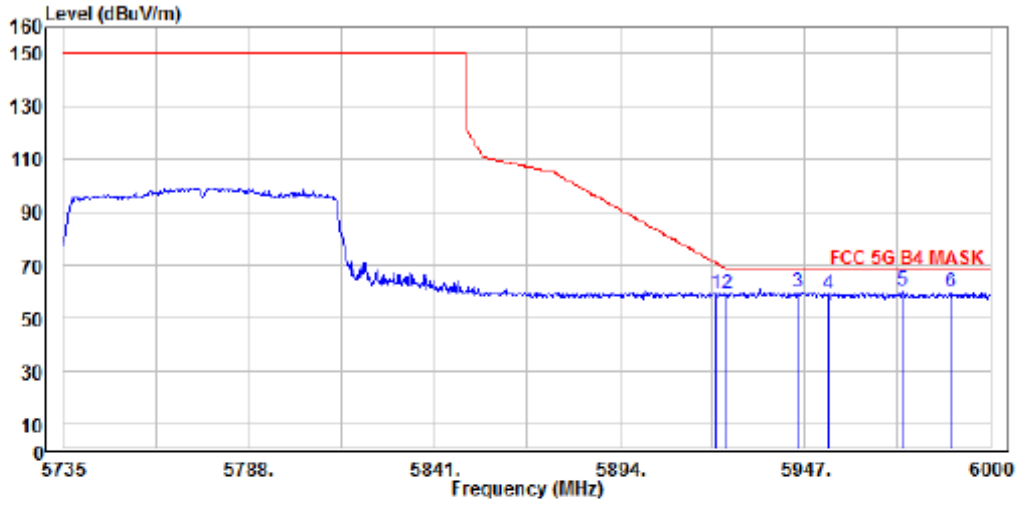

Condition: FCC 5G B4 MASK 3m factor\966 9120D H 1-18G.csv Horizontal
 : RBW:1000kHz VBW:1000kHz SWT:Auto DET:Positive
 Mode : 5GHz Band 4 ac80 high ch
 Note :

	Freq	Read Level	Factor	Level	Limit	Over	Pol/Phase
	MHz	dBuV	dB/m	dBuV/m	dBuV/m	dB	
1	5921.295	55.04	4.21	59.25	70.93	-11.68	Horizontal
2	5924.740	54.93	4.23	59.16	68.39	-9.23	Horizontal
3	5945.145	55.63	4.28	59.91	68.20	-8.29	Horizontal
4	5953.890	54.43	4.30	58.73	68.20	-9.47	Horizontal
5 PP	5974.825	55.90	4.35	60.25	68.20	-7.95	Horizontal
6	5988.605	55.02	4.39	59.41	68.20	-8.79	Horizontal

PIFA Ant

Band Edges test (Band UNII-1 / Band UNII-2A, 802.11a mode) -Radiated

Operation Mode	TX CH Low	Test Date	2020/04/07
Channel Number	5180 MHz	Test By	Barry
Temperature	25	Humidity	65 %

No	Freq MHz	Reading dBuV	Factor dB	Level dBuV/m	Limit dBuV/m	Margin dB	Remark	Pol V/H
1	5146.80	51.07	-8.55	42.52	54.00	-11.48	Average	VERTICAL
2	5146.80	65.67	-8.55	57.12	74.00	-16.88	Peak	VERTICAL
3	5150.00	53.55	-8.53	45.02	54.00	-8.98	Average	VERTICAL
4	5150.00	66.80	-8.53	58.27	74.00	-15.73	Peak	VERTICAL
5	5177.60	113.16	-8.48	104.68	F	--	Peak	VERTICAL
1	5147.50	52.07	-8.55	43.52	54.00	-10.48	Average	HORIZONTAL
2	5147.50	65.18	-8.55	56.63	74.00	-17.37	Peak	HORIZONTAL
3	5150.00	53.34	-8.53	44.81	54.00	-9.19	Average	HORIZONTAL
4	5150.00	66.49	-8.53	57.96	74.00	-16.04	Peak	HORIZONTAL
5	5179.00	111.07	-8.46	102.61	F	--	Peak	HORIZONTAL

Operation Mode	TX CH High	Test Date	2020/04/07
Channel Number	5320MHz	Test By	Barry
Temperature	25	Humidity	65 %

No	Freq MHz	Reading dBuV	Factor dB	Level dBuV/m	Limit dBuV/m	Margin dB	Remark	Pol V/H
1	5318.15	113.48	-8.17	105.31	F	--	Peak	VERTICAL
2	5350.00	61.67	-8.12	53.55	74.00	-20.45	Peak	VERTICAL
1	5320.55	110.00	-8.17	101.83	F	--	Peak	HORIZONTAL
2	5350.00	60.07	-8.12	51.95	74.00	-22.05	Peak	HORIZONTAL

Remark:

- Measuring frequencies from the lowest internal frequency to the 10th of fundamental frequency
- Field strength limits for frequency above 1000MHz are based on average limits. However, Peak mode field strength shall not exceed the average limits specified plus 20dB.
- Measurement of data within this frequency range shown “ - ” in the table above means the reading of emissions are attenuated more than 20dB below the permissible limits or the field strength is too small to be measured.
- Spectrum Peak mode IF bandwidth Setting : 1GHz- 40GHz, RBW= 1MHz, Sweep time= 200 ms., the VBW setting was 3 MHz.
- Spectrum AV mode if bandwidth Setting : 1GHz- 40GHz, RBW= 1MHz, VBW= 1kHz, Sweep time= 200 ms.

Band Edges test (Band UNII-1 / Band UNII-2A, 802.11n HT20 mode) -Radiated

Operation Mode	TX CH Low	Test Date	2020/04/07
Channel Number	5180 MHz	Test By	Barry
Temperature	25	Humidity	65 %

No	Freq MHz	Reading dBuV	Factor dB	Level dBuV/m	Limit dBuV/m	Margin dB	Remark	Pol V/H
1	5150.00	52.13	-8.53	43.60	54.00	-10.40	Average	VERTICAL
2	5150.00	69.18	-8.53	60.65	74.00	-13.35	Peak	VERTICAL
3	5179.70	113.32	-8.46	104.86	F	--	Peak	VERTICAL
1	5147.50	52.11	-8.55	43.56	54.00	-10.44	Average	HORIZONTAL
2	5147.50	67.77	-8.55	59.22	74.00	-14.78	Peak	HORIZONTAL
3	5150.00	53.20	-8.53	44.67	54.00	-9.33	Average	HORIZONTAL
4	5150.00	68.61	-8.53	60.08	74.00	-13.92	Peak	HORIZONTAL
5	5180.40	109.82	-8.46	101.36	F	--	Peak	HORIZONTAL

Operation Mode	TX CH High	Test Date	2020/04/07
Channel Number	5320MHz	Test By	Barry
Temperature	25	Humidity	65 %

No	Freq MHz	Reading dBuV	Factor dB	Level dBuV/m	Limit dBuV/m	Margin dB	Remark	Pol V/H
1	5318.75	112.03	-8.17	103.86	F	--	Peak	VERTICAL
2	5350.00	59.01	-8.12	50.89	74.00	-23.11	Peak	VERTICAL
1	5318.30	109.17	-8.17	101.00	F	--	Peak	HORIZONTAL
2	5350.00	51.17	-8.12	43.05	54.00	-10.95	Average	HORIZONTAL
3	5350.00	59.75	-8.12	51.63	74.00	-22.37	Peak	HORIZONTAL

Remark:

- Measuring frequencies from the lowest internal frequency to the 10th of fundamental frequency
- Field strength limits for frequency above 1000MHz are based on average limits. However, Peak mode field strength shall not exceed the average limits specified plus 20dB.
- Measurement of data within this frequency range shown “ - ” in the table above means the reading of emissions are attenuated more than 20dB below the permissible limits or the field strength is too small to be measured.
- Spectrum Peak mode IF bandwidth Setting : 1GHz- 40GHz, RBW= 1MHz, Sweep time= 200 ms., the VBW setting was 3 MHz.
- Spectrum AV mode if bandwidth Setting : 1GHz- 40GHz, RBW= 1MHz, VBW ≥ 1/Ton, Sweep time= 200 ms.

Band Edges test (Band UNII-1 / Band UNII-2A, 802.11n HT40 mode) -Radiated

Operation Mode TX CH Low Test Date 2020/04/07
 Channel Number 5190 MHz Test By Barry
 Temperature 25 Humidity 65 %

No	Freq MHz	Reading dBuV	Factor dB	Level dBuV/m	Limit dBuV/m	Margin dB	Remark	Pol V/H
1	5145.39	58.68	-8.56	50.12	54.00	-3.88	Average	VERTICAL
2	5145.39	69.71	-8.56	61.15	74.00	-12.85	Peak	VERTICAL
3	5150.00	54.20	-8.53	45.67	54.00	-8.33	Average	VERTICAL
4	5150.00	69.81	-8.53	61.28	74.00	-12.72	Peak	VERTICAL
5	5192.25	108.12	-8.44	99.68	F	--	Peak	VERTICAL
1	5150.00	53.61	-8.53	45.08	54.00	-8.92	Average	HORIZONTAL
2	5150.00	64.51	-8.53	55.98	74.00	-18.02	Peak	HORIZONTAL
3	5192.25	104.81	-8.44	96.37	F	--	Peak	HORIZONTAL

Operation Mode TX CH High Test Date 2020/04/07
 Channel Number 5310MHz Test By Barry
 Temperature 25 Humidity 65 %

No	Freq MHz	Reading dBuV	Factor dB	Level dBuV/m	Limit dBuV/m	Margin dB	Remark	Pol V/H
1	5311.60	109.20	-8.19	101.01	F	--	Peak	VERTICAL
2	5350.00	52.56	-8.12	44.44	54.00	-9.56	Average	VERTICAL
3	5350.00	71.11	-8.12	62.99	74.00	-11.01	Peak	VERTICAL
4	5353.68	52.93	-8.10	44.83	54.00	-9.17	Average	VERTICAL
5	5353.68	74.73	-8.10	66.63	74.00	-7.37	Peak	VERTICAL
1	5313.84	106.34	-8.19	98.15	F	--	Peak	HORIZONTAL
2	5350.00	54.24	-8.12	46.12	54.00	-7.88	Average	HORIZONTAL
3	5350.00	66.04	-8.12	57.92	74.00	-16.08	Peak	HORIZONTAL
4	5351.76	52.15	-8.11	44.04	54.00	-9.96	Average	HORIZONTAL
5	5351.76	72.03	-8.11	63.92	74.00	-10.08	Peak	HORIZONTAL

Remark:

- 1 Measuring frequencies from the lowest internal frequency to the 10th of fundamental frequency
- 2 Field strength limits for frequency above 1000MHz are based on average limits. However, Peak mode field strength shall not exceed the average limits specified plus 20dB.
- 3 Measurement of data within this frequency range shown “ - ” in the table above means the reading of emissions are attenuated more than 20dB below the permissible limits or the field strength is too small to be measured.
- 4 Spectrum Peak mode IF bandwidth Setting : 1GHz- 40GHz, RBW= 1MHz, Sweep time= 200 ms., the VBW setting was 3 MHz.
- 5 Spectrum AV mode if bandwidth Setting : 1GHz- 40GHz, RBW= 1MHz, VBW ≥ 1/Ton, Sweep time= 200 ms.

Band Edges test (Band UNII-1 / Band UNII-2A, 802.11ac VHT80 mode) -Radiated

Operation Mode TX CH Low Test Date 2020/04/07
 Channel Number 5210 MHz Test By Barry
 Temperature 25 Humidity 65 %

No	Freq MHz	Reading dBuV	Factor dB	Level dBuV/m	Limit dBuV/m	Margin dB	Remark	Pol V/H
1	5116.50	57.14	-8.63	48.51	54.00	-5.49	Average	VERTICAL
2	5116.50	72.56	-8.63	63.93	74.00	-10.07	Peak	VERTICAL
3	5145.00	55.22	-8.56	46.66	54.00	-7.34	Average	VERTICAL
4	5145.00	79.56	-8.56	71.00	74.00	-3.00	Peak	VERTICAL
5	5150.00	62.09	-8.53	53.56	54.00	-0.44	Average	VERTICAL
6	5150.00	75.03	-8.53	66.50	74.00	-7.5	Peak	VERTICAL
7	5205.00	107.91	-8.41	99.50	F	--	Peak	VERTICAL
1	5147.25	53.62	-8.55	45.07	54.00	-8.93	Average	HORIZONTAL
2	5147.25	69.43	-8.55	60.88	74.00	-13.12	Peak	HORIZONTAL
3	5150.00	54.11	-8.35	45.76	54.00	-8.24	Average	HORIZONTAL
4	5150.00	68.07	-8.53	59.54	74.00	-14.46	Peak	HORIZONTAL
5	5212.50	105.42	-8.39	97.03	F	--	Peak	HORIZONTAL

Operation Mode TX CH High Test Date 2020/04/07
 Channel Number 5290MHz Test By Barry
 Temperature 25 Humidity 65 %

No	Freq MHz	Reading dBuV	Factor dB	Level dBuV/m	Limit dBuV/m	Margin dB	Remark	Pol V/H
1	5290.80	106.49	-8.23	98.26	F	--	Peak	VERTICAL
2	5350.00	56.22	-8.12	48.10	54.00	-5.90	Average	VERTICAL
3	5350.00	71.39	-8.12	63.27	74.00	-10.73	Peak	VERTICAL
4	5357.40	54.60	-8.09	46.51	54.00	-7.49	Average	VERTICAL
5	5357.40	72.87	-8.09	64.78	74.00	-9.22	Peak	VERTICAL
1	5286.20	102.06	-8.24	93.82	F	--	Peak	HORIZONTAL
2	5350.00	55.58	-8.12	47.46	54.00	-6.54	Average	HORIZONTAL
3	5350.00	64.29	-8.12	56.17	74.00	-17.83	Peak	HORIZONTAL
4	5353.20	54.26	-8.10	46.16	54.00	-7.84	Average	HORIZONTAL
5	5353.20	68.96	-8.10	60.86	74.00	-13.14	Peak	HORIZONTAL

Remark:

- 1 Measuring frequencies from the lowest internal frequency to the 10th of fundamental frequency
- 2 Field strength limits for frequency above 1000MHz are based on average limits. However, Peak mode field strength shall not exceed the average limits specified plus 20dB.
- 3 Measurement of data within this frequency range shown “ - ” in the table above means the reading of emissions are attenuated more than 20dB below the permissible limits or the field strength is too small to be measured.
- 4 Spectrum Peak mode IF bandwidth Setting : 1GHz- 40GHz, RBW= 1MHz, Sweep time= 200 ms., the VBW setting was 3 MHz.
- 5 Spectrum AV mode if bandwidth Setting : 1GHz- 40GHz, RBW= 1MHz, VBW ≥ 1/Ton, Sweep time= 200 ms.

Band Edges test (Band UNII-2C, 802.11a mode) -Radiated

Operation Mode	TX CH Low	Test Date	2020/04/07
Channel Number	5500 MHz	Test By	Barry
Temperature	25	Humidity	65 %

No	Freq MHz	Reading dBuV	Factor dB	Level dBuV/m	Limit dBuV/m	Margin dB	Remark	Pol V/H
1	5470.00	63.55	-7.79	55.76	68.20	-12.44	Peak	VERTICAL
2	5498.89	111.34	-7.70	103.64	F	--	Peak	VERTICAL
1	5470.00	60.88	-7.79	53.09	68.20	-15.11	Peak	HORIZONTAL
2	5498.78	106.13	-7.70	98.43	F	--	Peak	HORIZONTAL

Operation Mode	TX CH High	Test Date	2020/04/07
Channel Number	5700MHz	Test By	Barry
Temperature	25	Humidity	65 %

No	Freq MHz	Reading dBuV	Factor dB	Level dBuV/m	Limit dBuV/m	Margin dB	Remark	Pol V/H
1	5698.16	112.24	-7.03	105.21	F	--	Peak	VERTICAL
2	5725.00	65.21	-6.95	58.26	68.20	-9.94	Peak	VERTICAL
1	5698.00	106.72	-7.03	99.69	F	--	Peak	HORIZONTAL
2	5725.00	61.63	-6.95	54.68	68.20	-13.52	Peak	HORIZONTAL

Remark:

- 1 Measuring frequencies from the lowest internal frequency to the 10th of fundamental frequency
- 2 Field strength limits for frequency above 1000MHz are based on average limits. However, Peak mode field strength shall not exceed the average limits specified plus 20dB.
- 3 Measurement of data within this frequency range shown “ - ” in the table above means the reading of emissions are attenuated more than 20dB below the permissible limits or the field strength is too small to be measured.
- 4 Spectrum Peak mode IF bandwidth Setting : 1GHz- 40GHz, RBW= 1MHz, Sweep time= 200 ms., the VBW setting was 3 MHz.
- 5 Spectrum AV mode if bandwidth Setting : 1GHz- 40GHz, RBW= 1MHz, VBW= 1kHz, Sweep time= 200 ms.

Band Edges test (Band UNII-2C, 802.11n HT20 mode) -Radiated

Operation Mode	TX CH Low	Test Date	2020/04/07
Channel Number	5500 MHz	Test By	Barry
Temperature	25	Humidity	65 %

No	Freq MHz	Reading dBuV	Factor dB	Level dBuV/m	Limit dBuV/m	Margin dB	Remark	Pol V/H
1	5470.00	63.63	-7.79	55.84	68.20	-12.36	Peak	VERTICAL
2	5498.56	110.11	-7.70	102.41	F	--	Peak	VERTICAL
1	5470.00	62.27	-7.79	54.48	68.20	-13.72	Peak	HORIZONTAL
2	5498.67	105.65	-7.70	97.95	F	--	Peak	HORIZONTAL

Operation Mode	TX CH High	Test Date	2020/04/07
Channel Number	5700MHz	Test By	Barry
Temperature	25	Humidity	65 %

No	Freq MHz	Reading dBuV	Factor dB	Level dBuV/m	Limit dBuV/m	Margin dB	Remark	Pol V/H
1	5701.04	111.22	-7.03	104.19	F	--	Peak	VERTICAL
2	5725.00	66.69	-6.95	59.74	68.20	-8.46	Peak	VERTICAL
1	5701.20	105.40	-7.03	98.37	F	--	Peak	HORIZONTAL
2	5725.00	61.91	-6.95	54.96	68.20	-13.24	Peak	HORIZONTAL

Remark:

- 1 Measuring frequencies from the lowest internal frequency to the 10th of fundamental frequency
- 2 Field strength limits for frequency above 1000MHz are based on average limits. However, Peak mode field strength shall not exceed the average limits specified plus 20dB.
- 3 Measurement of data within this frequency range shown “ - ” in the table above means the reading of emissions are attenuated more than 20dB below the permissible limits or the field strength is too small to be measured.
- 4 Spectrum Peak mode IF bandwidth Setting : 1GHz- 40GHz, RBW= 1MHz, Sweep time= 200 ms., the VBW setting was 3 MHz.
- 5 Spectrum AV mode if bandwidth Setting : 1GHz- 40GHz, RBW= 1MHz, VBW ≥ 1/Ton, Sweep time= 200 ms.

Band Edges test (Band UNII-2C, 802.11n HT40 mode) -Radiated

Operation Mode	TX CH Low	Test Date	2020/04/07
Channel Number	5510 MHz	Test By	Barry
Temperature	25	Humidity	65 %

No	Freq MHz	Reading dBuV	Factor dB	Level dBuV/m	Limit dBuV/m	Margin dB	Remark	Pol V/H
1	5456.03	53.16	-7.83	45.33	54.00	-8.67	Average	VERTICAL
2	5456.03	66.66	-7.83	58.83	74.00	-15.17	Peak	VERTICAL
3	5470.00	70.52	-7.79	62.73	68.20	-5.47	Peak	VERTICAL
4	5511.15	107.07	-7.66	99.41	F	--	Peak	VERTICAL
1	5470.00	63.26	-7.79	55.47	68.20	-12.73	Peak	HORIZONTAL
2	5512.19	102.85	-7.66	95.19	F	--	Peak	HORIZONTAL

Operation Mode	TX CH High	Test Date	2020/04/07
Channel Number	5670MHz	Test By	Barry
Temperature	25	Humidity	65 %

No	Freq MHz	Reading dBuV	Factor dB	Level dBuV/m	Limit dBuV/m	Margin dB	Remark	Pol V/H
1	5671.40	107.94	-7.13	100.81	F	--	Peak	VERTICAL
2	5725.00	60.03	-6.95	53.08	68.20	-15.12	Peak	VERTICAL
1	5675.40	103.60	-7.12	96.48	F	--	Peak	HORIZONTAL
2	5725.00	58.54	-6.95	51.59	68.20	-16.61	Peak	HORIZONTAL

Remark:

- 1 Measuring frequencies from the lowest internal frequency to the 10th of fundamental frequency
- 2 Field strength limits for frequency above 1000MHz are based on average limits. However, Peak mode field strength shall not exceed the average limits specified plus 20dB.
- 3 Measurement of data within this frequency range shown “ - ” in the table above means the reading of emissions are attenuated more than 20dB below the permissible limits or the field strength is too small to be measured.
- 4 Spectrum Peak mode IF bandwidth Setting : 1GHz- 40GHz, RBW= 1MHz, Sweep time= 200 ms., the VBW setting was 3 MHz.
- 5 Spectrum AV mode if bandwidth Setting : 1GHz- 40GHz, RBW= 1MHz, VBW ≥ 1/Ton, Sweep time= 200 ms.

Band Edges test (Band UNII-2C, 802.11ac VHT80 mode) -Radiated

Operation Mode	TX CH Low	Test Date	2020/04/07
Channel Number	5530 MHz	Test By	Barry
Temperature	25	Humidity	65 %

No	Freq MHz	Reading dBuV	Factor dB	Level dBuV/m	Limit dBuV/m	Margin dB	Remark	Pol V/H
1	5455.25	52.56	-7.83	44.73	54.00	-9.27	Average	VERTICAL
2	5455.25	66.81	-7.83	58.98	74.00	-15.02	Peak	VERTICAL
3	5470.00	70.22	-7.79	62.43	68.20	-5.77	Peak	VERTICAL
4	5536.85	104.75	-7.58	97.17	F	--	Peak	VERTICAL
1	5443.86	52.17	-7.88	44.29	54.00	-9.71	Average	HORIZONTAL
2	5443.86	65.92	-7.88	58.04	74.00	-15.96	Peak	HORIZONTAL
3	5453.21	54.54	-7.85	46.69	54.00	-7.31	Average	HORIZONTAL
4	5453.21	67.33	-7.85	59.48	74.00	-14.52	Peak	HORIZONTAL
5	5470.00	67.58	-7.79	59.79	68.20	-8.41	Peak	HORIZONTAL
6	5521.89	101.29	-7.63	93.66	F	--	Peak	HORIZONTAL

Operation Mode	TX CH High	Test Date	2020/04/07
Channel Number	5610MHz	Test By	Barry
Temperature	25	Humidity	65 %

No	Freq MHz	Reading dBuV	Factor dB	Level dBuV/m	Limit dBuV/m	Margin dB	Remark	Pol V/H
1	5612.84	104.49	-7.35	97.14	F	--	Peak	VERTICAL
2	5725.00	56.30	-6.95	49.35	68.20	-18.85	Peak	VERTICAL
1	5602.48	100.85	-7.38	93.47	F	--	Peak	HORIZONTAL
2	5725.00	55.98	-6.95	49.03	68.20	-19.17	Peak	HORIZONTAL

Remark:

- 1 Measuring frequencies from the lowest internal frequency to the 10th of fundamental frequency
- 2 Field strength limits for frequency above 1000MHz are based on average limits. However, Peak mode field strength shall not exceed the average limits specified plus 20dB.
- 3 Measurement of data within this frequency range shown “ - ” in the table above means the reading of emissions are attenuated more than 20dB below the permissible limits or the field strength is too small to be measured.
- 4 Spectrum Peak mode IF bandwidth Setting : 1GHz- 40GHz, RBW= 1MHz, Sweep time= 200 ms., the VBW setting was 3 MHz.
- 5 Spectrum AV mode if bandwidth Setting : 1GHz- 40GHz, RBW= 1MHz, VBW \geq 1/Ton, Sweep time= 200 ms.

Band Edges test (Band UNII-3, 802.11a mode) –Radiated

Operation Mode	TX CH Low	Test Date	2020/01/21
Channel Number	5745 MHz	Test By	Barry
Temperature	25	Humidity	65 %

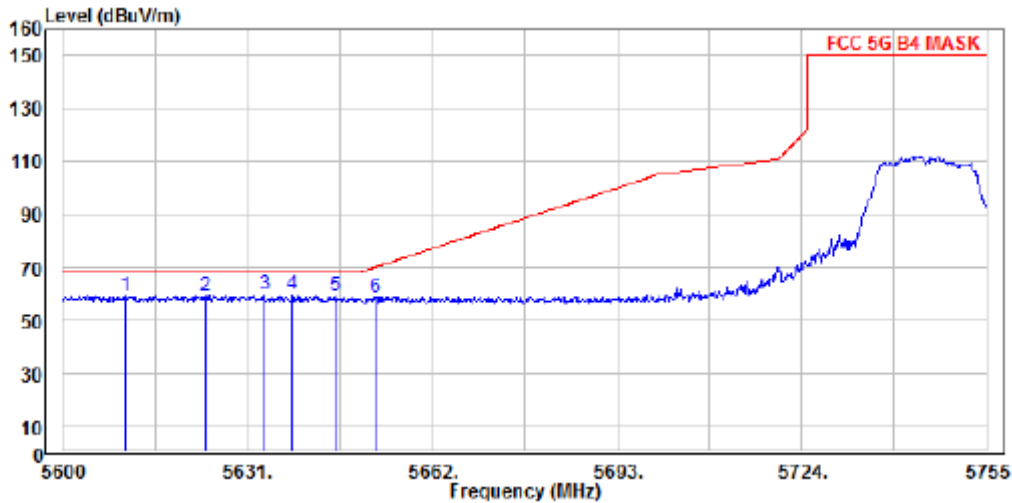

Condition: FCC 5G B4 MASK 3m factor\966 9128D V 1-18G.csv Vertical
 : RBW:1000kHz VBW:1000kHz SWT:Auto DET:Positive
 Mode : 5GHz Band a 20 low ch
 Note :

	Read		Limit	Over		
Freq	Level	Factor	Level	Line	Limit	Pol/Phase
MHz	dBuV	dB/m	dBuV/m	dBuV/m	dB	
1	5610.385	55.34	3.42	58.76	68.20	-9.44 Vertical
2	5623.870	55.55	3.46	59.01	68.20	-9.19 Vertical
3	5633.790	56.12	3.47	59.59	68.20	-8.61 Vertical
4 PP	5638.440	56.17	3.49	59.66	68.20	-8.54 Vertical
5	5645.570	55.26	3.51	58.77	68.20	-9.43 Vertical
6	5652.390	55.13	3.53	58.66	69.98	-11.32 Vertical

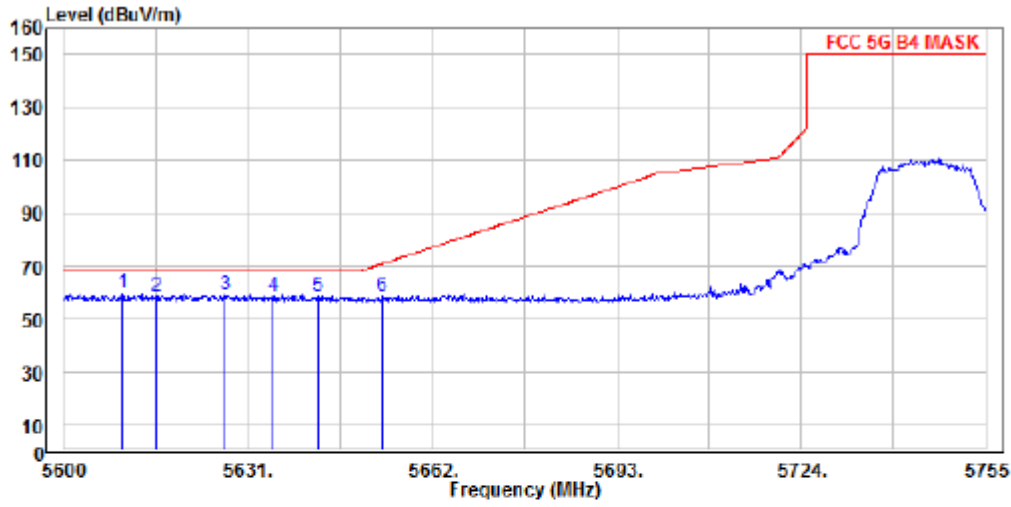

Condition: FCC 5G B4 MASK 3m factor\966 9120D H 1-18G.csv Horizontal
 : RBW:1000kHz VBW:1000kHz SWT:Auto DET:Positive
 Mode : 5GHz Band a 20 low ch
 Note :

	Read Freq	Read Level	Read Factor	Level	Limit	Over	Pol/Phase
	MHz	dBuV	dB/m	dBuV/m	dBuV/m	dB	
1	5609.765	55.95	3.42	59.37	68.20	-8.83	Horizontal
2	5615.500	55.02	3.43	58.45	68.20	-9.75	Horizontal
3	5626.970	55.80	3.46	59.26	68.20	-8.94	Horizontal
4	5635.185	54.90	3.48	58.38	68.20	-9.82	Horizontal
5	5642.625	54.83	3.50	58.33	68.20	-9.87	Horizontal
6	5653.475	54.74	3.53	58.27	70.78	-12.51	Horizontal

Operation Mode TX CH High
 Channel Number 5825MHz
 Temperature 25

Test Date 2020/01/21
 Test By Barry
 Humidity 65 %

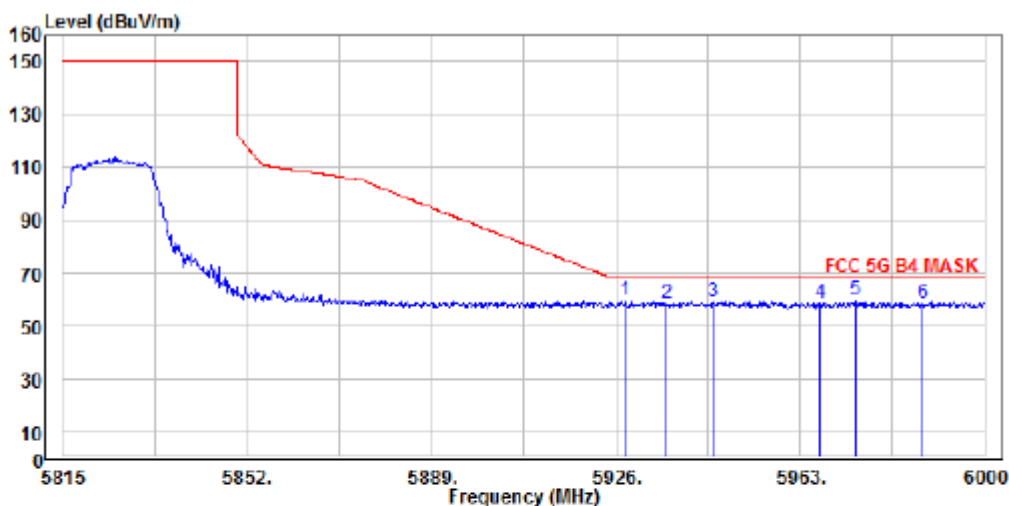

Condition: FCC 5G B4 MASK 3m factor\966 9120D V 1-18G.csv Vertical
 : RBW:1000kHz VBW:1000kHz SWT:Auto DET:Positive
 Mode : 5GHz Band a 20 high ch
 Note :

	Read Freq	Read Level	Factor	Limit Level	Over Limit	Pol/Phase
	MHz	dBuV	dB/m	dBuV/m	dBuV/m	dB
1	5927.850	55.41	4.23	59.64	68.20	-8.56 Vertical
2	5935.990	54.07	4.26	58.33	68.20	-9.87 Vertical
3	5945.610	54.89	4.28	59.17	68.20	-9.03 Vertical
4	5966.885	53.96	4.34	58.30	68.20	-9.90 Vertical
5	5974.100	55.46	4.35	59.81	68.20	-8.39 Vertical
6	5987.605	54.20	4.39	58.59	68.20	-9.61 Vertical

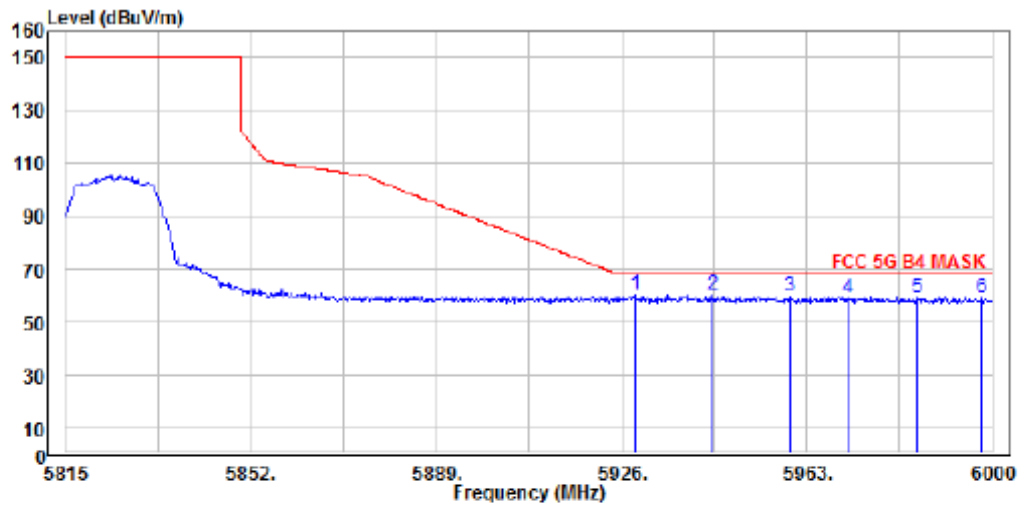

Condition: FCC 5G B4 MASK 3m factor\966 9120D H 1-18G.csv Horizontal
 : RBW:1000kHz VBW:1000kHz SWT:Auto DET:Positive
 Mode : 5GHz Band a 20 high ch
 Note :

	Read	Limit	Over			
Freq	Level	Factor	Level	Line	Limit	Pol/Phase
MHz	dBuV	dB/m	dBuV/m	dBuV/m	dB	
1 PP 5928.590	55.94	4.23	60.17	68.20	-8.03	Horizontal
2 5944.315	55.89	4.27	60.16	68.20	-8.04	Horizontal
3 5959.485	55.35	4.31	59.66	68.20	-8.54	Horizontal
4 5971.140	54.73	4.35	59.08	68.20	-9.12	Horizontal
5 5985.015	54.47	4.38	58.85	68.20	-9.35	Horizontal
6 5997.965	54.55	4.42	58.97	68.20	-9.23	Horizontal

Band Edges test (Band UNII-3, 802.11n HT20 mode) –Radiated

Operation Mode TX CH Low
 Channel Number 5745 MHz
 Temperature 25

Test Date 2020/01/21
 Test By Barry
 Humidity 65 %

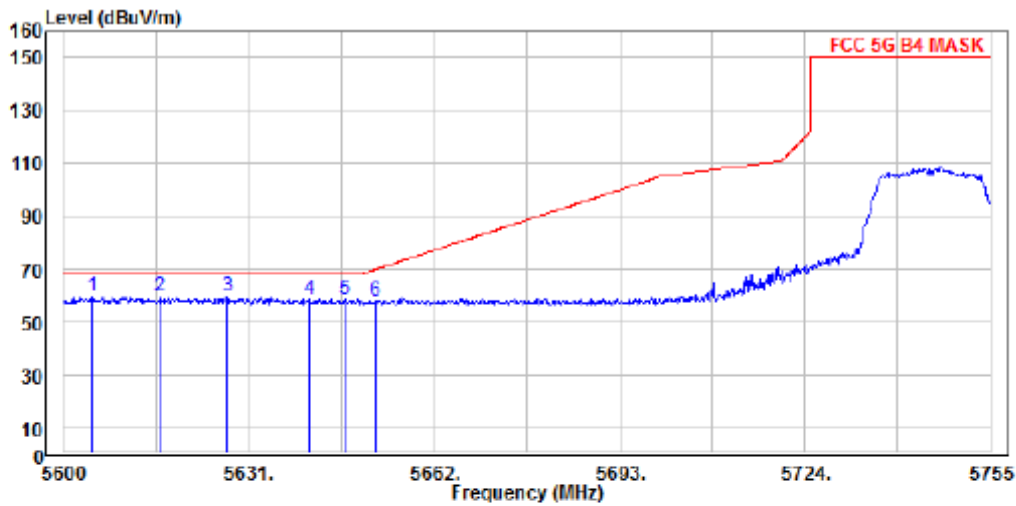

Condition: FCC 5G B4 MASK 3m factor\966 9120D V 1-18G.csv Vertical
 : RBW:1000kHz VBW:1000kHz SWT:Auto DET:Positive
 Mode : 5GHz Band n20 low ch
 Note :

	Read Freq	Read Level	Read Factor	Read Level	Limit Line	Over Limit	Pol/Phase
	MHz	dBuV	dB/m	dBuV/m	dBuV/m	dB	
1	5604.650	55.93	3.40	59.33	68.20	-8.87	Vertical
2	5616.120	56.15	3.43	59.58	68.20	-8.62	Vertical
3 PP	5627.280	56.23	3.46	59.69	68.20	-8.51	Vertical
4	5641.230	55.10	3.50	58.60	68.20	-9.60	Vertical
5	5646.965	54.78	3.51	58.29	68.20	-9.91	Vertical
6	5652.080	54.50	3.53	58.03	69.75	-11.72	Vertical

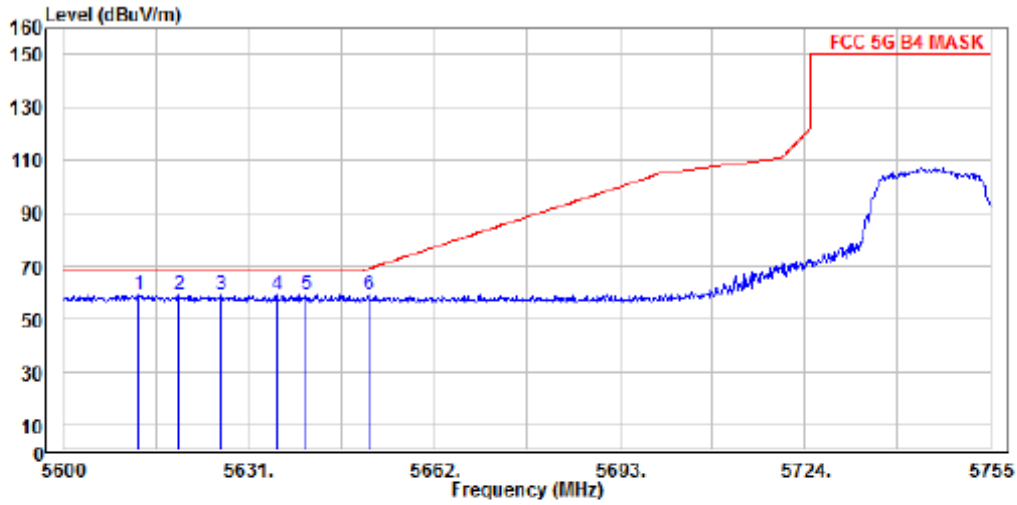

Condition: FCC 5G B4 MASK 3m factor\966 9120D H 1-18G.csv Horizontal
 : RBW:1000kHz VBW:1000kHz SWT:Auto DET:Positive
 Mode : 5GHz Band n20 low ch
 Note :

	Read		Limit	Over		
Freq	Level	Factor	Level	Line	Limit	Pol/Phase
MHz	dBuV	dB/m	dBuV/m	dBuV/m	dB	
1	5612.555	55.37	3.42	58.79	68.20	-9.41 Horizontal
2	5619.375	55.39	3.44	58.83	68.20	-9.37 Horizontal
3	5626.350	55.57	3.46	59.03	68.20	-9.17 Horizontal
4	5635.650	55.33	3.48	58.81	68.20	-9.39 Horizontal
5 PP	5640.610	55.69	3.50	59.19	68.20	-9.01 Horizontal
6	5650.995	55.32	3.53	58.85	68.94	-10.09 Horizontal

Operation Mode TX CH High
 Channel Number 5825 MHz
 Temperature 25

Test Date 2020/01/21
 Test By Barry
 Humidity 65 %

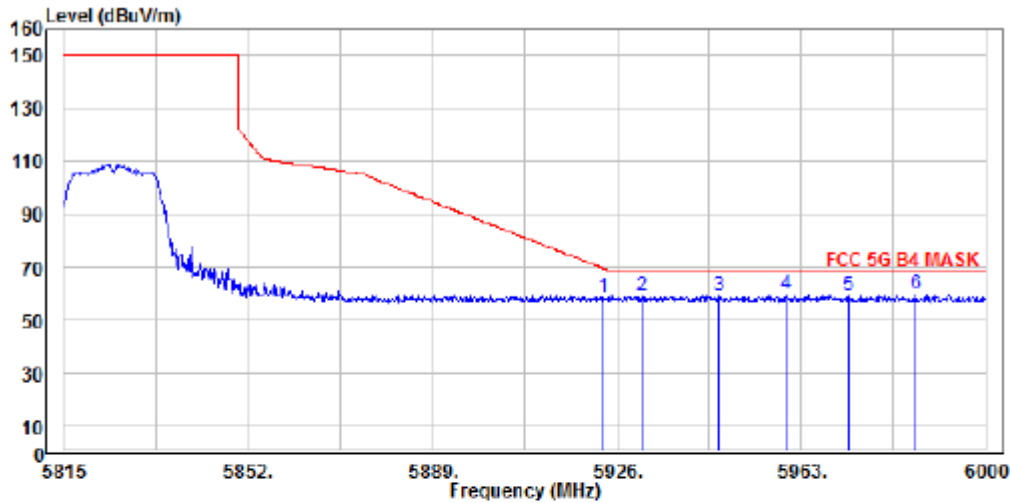

Condition: FCC 5G B4 MASK 3m factor\966 9128D V 1-18G.csv Vertical
 : RBW:1000kHz VBW:1000kHz SWT:Auto DET:Positive
 Mode : 5GHz Band n20 high ch
 Note :

	Read		Limit	Over		
Freq	Level	Factor	Level	Line	Limit	Pol/Phase
MHz	dBuV	dB/m	dBuV/m	dBuV/m	dB	
1	5923.225	54.26	4.22	58.48	69.51	-11.03 Vertical
2	5930.995	54.53	4.24	58.77	68.20	-9.43 Vertical
3	5946.350	55.03	4.28	59.31	68.20	-8.89 Vertical
4 PP	5960.840	55.39	4.31	59.70	68.20	-8.50 Vertical
5	5972.620	54.75	4.35	59.10	68.20	-9.10 Vertical
6	5986.125	55.20	4.38	59.58	68.20	-8.62 Vertical

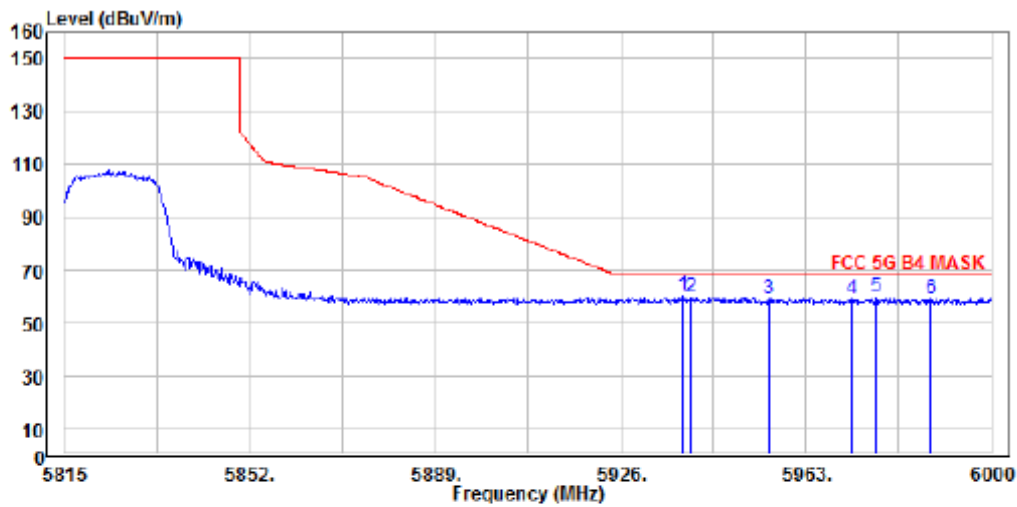

Condition: FCC 5G B4 MASK 3m factor\966 9120D H 1-18G.csv Horizontal
 : RBW:1000kHz VBW:1000kHz SWT:Auto DET:Positive
 Mode : 5GHz Band n20 high ch
 Note :

	Read Freq	Read Level	Factor	Limit Level	Over Limit	Pol/Phase
	MHz	dBuV	dB/m	dBuV/m	dBuV/m	dB
1 PP	5938.395	55.67	4.26	59.93	68.20	-8.27 Horizontal
2	5940.060	55.53	4.27	59.80	68.20	-8.40 Horizontal
3	5955.600	54.74	4.31	59.05	68.20	-9.15 Horizontal
4	5972.065	54.73	4.35	59.08	68.20	-9.12 Horizontal
5	5977.060	55.16	4.36	59.52	68.20	-8.68 Horizontal
6	5987.790	54.66	4.39	59.05	68.20	-9.15 Horizontal

Band Edges test (Band UNII-3, 802.11n HT40 mode) –Radiated

Operation Mode TX CH Low
 Channel Number 5755 MHz
 Temperature 25

Test Date 2020/01/21
 Test By Barry
 Humidity 65 %

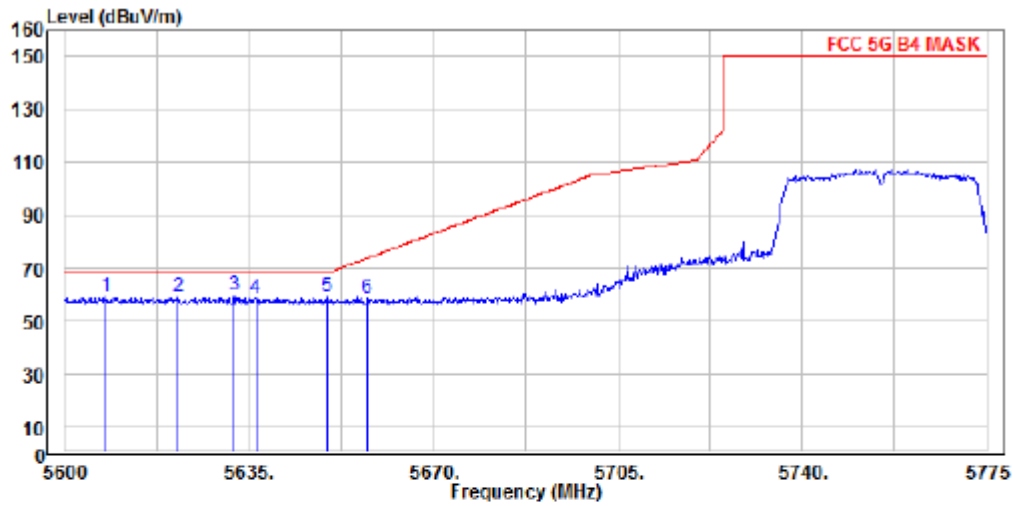

Condition: FCC 5G B4 MASK 3m factor\966 9120D V 1-18G.csv Vertical
 : RBW:1000kHz VBW:1000kHz SWT:Auto DET:Positive
 Mode : 5GHz Band n40 low ch
 Note :

	Read			Limit	Over	
Freq	Level	Factor	Level	Line	Limit	Pol/Phase
MHz	dBuV	dB/m	dBuV/m	dBuV/m	dB	
1	5607.875	55.30	3.41	58.71	68.20	-9.49 Vertical
2	5621.525	55.37	3.45	58.82	68.20	-9.38 Vertical
3 PP	5632.200	56.03	3.47	59.50	68.20	-8.70 Vertical
4	5636.225	54.96	3.49	58.45	68.20	-9.75 Vertical
5	5649.875	55.53	3.51	59.04	68.20	-9.16 Vertical
6	5657.400	54.89	3.54	58.43	73.70	-15.27 Vertical

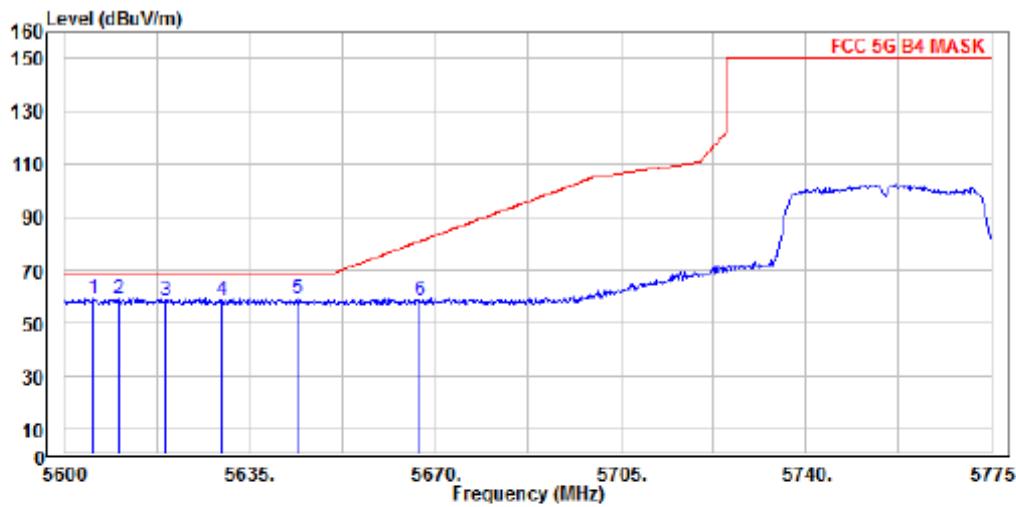

Condition: FCC 5G B4 MASK 3m factor\966 9120D H 1-18G.csv Horizontal
 : RBW:1000kHz VBW:1000kHz SWT:Auto DET:Positive
 Mode : 5GHz Band n40 low ch
 Note :

	Read Freq	Read Level	Read Factor	Limit Level	Over Limit	Pol/Phase
	MHz	dBuV	dB/m	dBuV/m	dBuV/m	dB
1	5605.425	55.35	3.40	58.75	68.20	-9.45 Horizontal
2	5610.150	55.41	3.42	58.83	68.20	-9.37 Horizontal
3	5619.075	55.21	3.44	58.65	68.20	-9.55 Horizontal
4	5629.750	55.06	3.47	58.53	68.20	-9.67 Horizontal
5 PP	5644.100	55.44	3.50	58.94	68.20	-9.26 Horizontal
6	5667.200	55.12	3.57	58.69	80.96	-22.27 Horizontal

Operation Mode TX CH High
 Channel Number 5795MHz
 Temperature 25

Test Date 2020/01/21
 Test By Barry
 Humidity 65 %

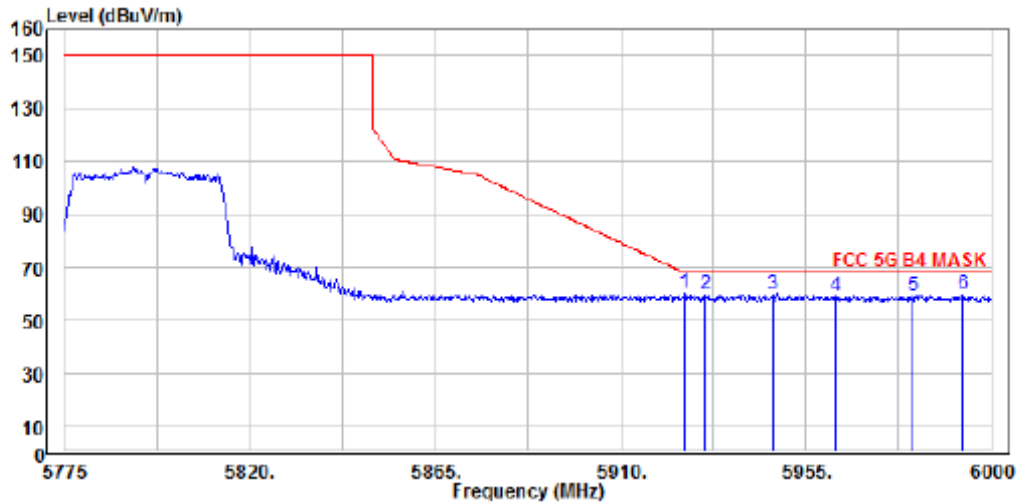

Condition: FCC 5G B4 MASK 3m factor\966 9120D V 1-18G.csv Vertical
 : RBW:1000kHz VBW:1000kHz SWT:Auto DET:Positive
 Mode : 5GHz Band n40 high ch
 Note :

	Read		Limit	Over		
Freq	Level	Factor	Level	Line	Limit	Pol/Phase
MHz	dBuV	dB/m	dBuV/m	dBuV/m	dB	
1 PP 5925.525	55.94	4.23	60.17	68.20	-8.03	Vertical
2 5930.475	55.22	4.24	59.46	68.20	-8.74	Vertical
3 5947.125	55.32	4.28	59.60	68.20	-8.60	Vertical
4 5962.425	54.63	4.32	58.95	68.20	-9.25	Vertical
5 5981.100	54.67	4.37	59.04	68.20	-9.16	Vertical
6 5993.250	54.96	4.41	59.37	68.20	-8.83	Vertical

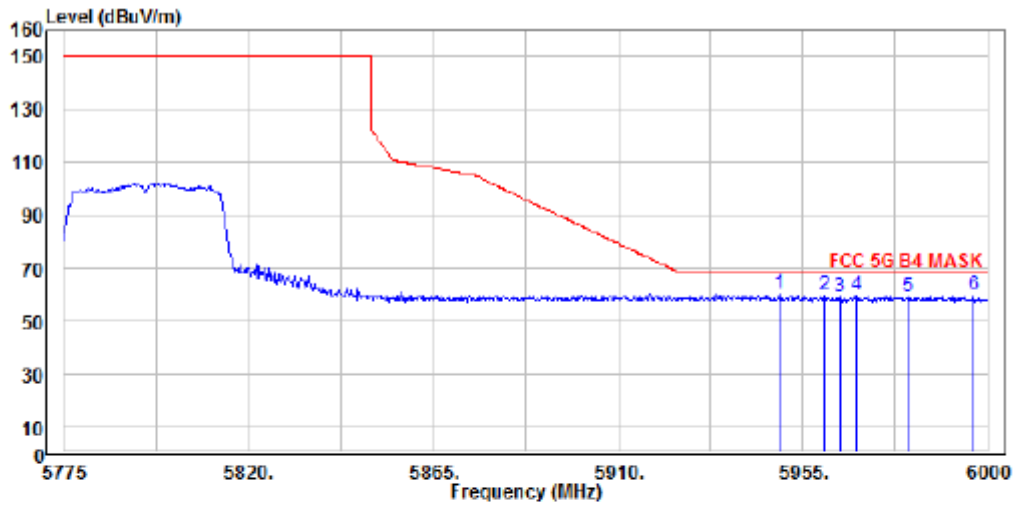

Condition: FCC 5G B4 MASK 3m factor\966 9128D H 1-18G.csv Horizontal
 : RBW:1000kHz VBW:1000kHz SWT:Auto DET:Positive
 Mode : 5GHz Band n40 high ch
 Note :

	Read		Limit	Over		
Freq	Level	Factor	Level	Line	Limit	Pol/Phase
MHz	dBuV	dB/m	dBuV/m	dBuV/m	dB	
1 PP 5949.150	56.04	4.28	60.32	68.20	-7.88	Horizontal
2 5960.400	55.08	4.31	59.39	68.20	-8.81	Horizontal
3 5964.000	54.76	4.32	59.08	68.20	-9.12	Horizontal
4 5968.275	55.13	4.34	59.47	68.20	-8.73	Horizontal
5 5980.650	54.78	4.37	59.15	68.20	-9.05	Horizontal
6 5996.850	54.96	4.41	59.37	68.20	-8.83	Horizontal

Band Edges test (Band UNII-3, 802.11ac VHT80 mode) –Radiated

Operation Mode	TX CH Low	Test Date	2020/01/21
Channel Number	5775 MHz	Test By	Barry
Temperature	25	Humidity	65 %

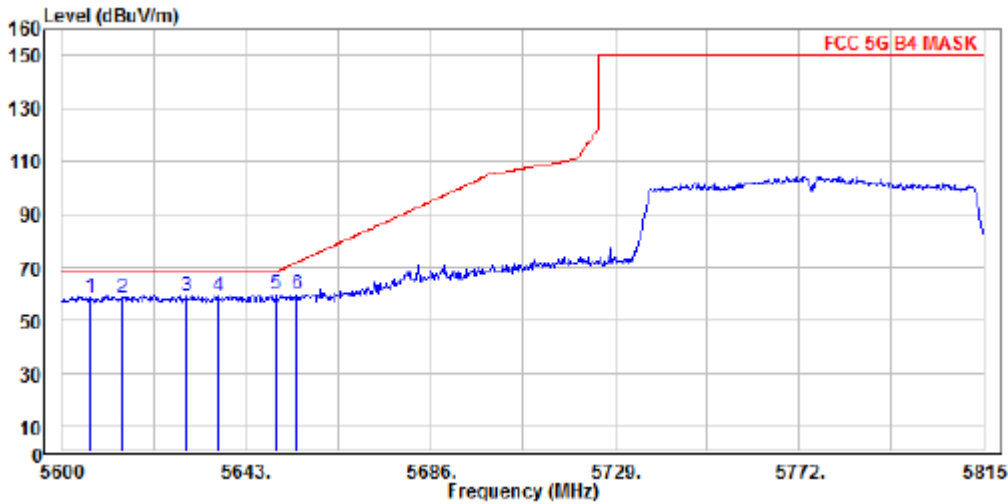

Condition: FCC 5G B4 MASK 3m factor\966 9120D V 1-18G.csv Vertical
 : RBW:1000kHz VBW:1000kHz SWT:Auto DET:Positive
 Mode : 5GHz Band ac80 low ch
 Note :

	Read Freq	Read Level	Factor	Level	Limit	Over	Pol/Phase
	MHz	dBuV	dB/m	dBuV/m	dBuV/m	dB	
1	5606.450	55.06	3.40	58.46	68.20	-9.74	Vertical
2	5614.190	54.97	3.43	58.40	68.20	-9.80	Vertical
3	5629.025	55.53	3.47	59.00	68.20	-9.20	Vertical
4	5636.550	55.43	3.49	58.92	68.20	-9.28	Vertical
5 PP	5650.095	56.14	3.53	59.67	68.27	-8.60	Vertical
6	5654.825	56.25	3.53	59.78	71.78	-12.00	Vertical

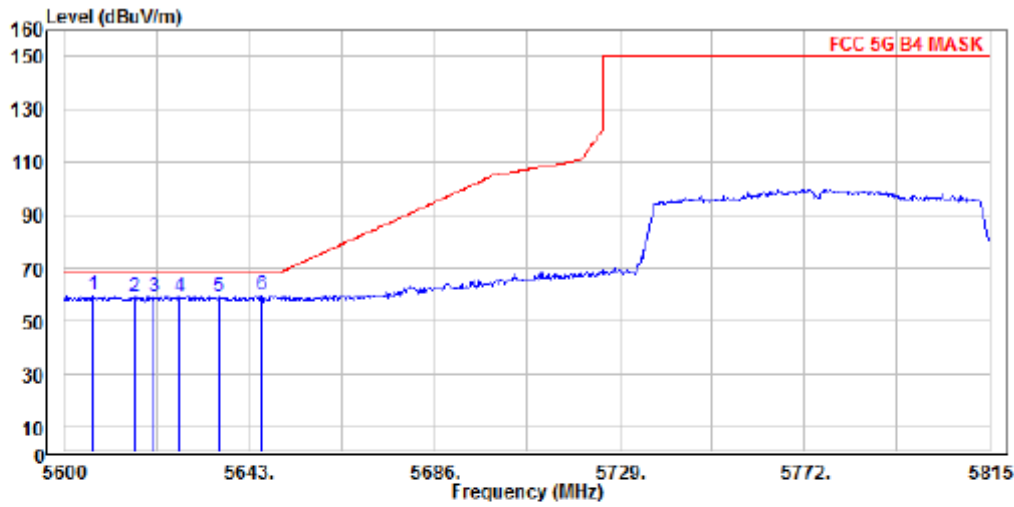

Condition: FCC 5G B4 MASK 3m factor\966 9120D H 1-18G.csv Horizontal
 : RBW:1000kHz VBW:1000kHz SWT:Auto DET:Positive
 Mode : 5GHz Band ac80 low ch
 Note :

		Read		Limit	Over	
	Freq	Level	Factor	Level	Line	Limit Pol/Phase
	MHz	dBuV	dB/m	dBuV/m	dBuV/m	dB
1 PP	5606.665	56.32	3.40	59.72	68.20	-8.48 Horizontal
2	5616.125	55.55	3.43	58.98	68.20	-9.22 Horizontal
3	5620.855	55.60	3.44	59.04	68.20	-9.16 Horizontal
4	5626.875	55.63	3.46	59.09	68.20	-9.11 Horizontal
5	5635.905	55.26	3.49	58.75	68.20	-9.45 Horizontal
6	5645.795	55.99	3.51	59.50	68.20	-8.70 Horizontal

Operation Mode TX CH High
 Channel Number 5775MHz
 Temperature 25

Test Date 2020/01/21
 Test By Barry
 Humidity 65 %

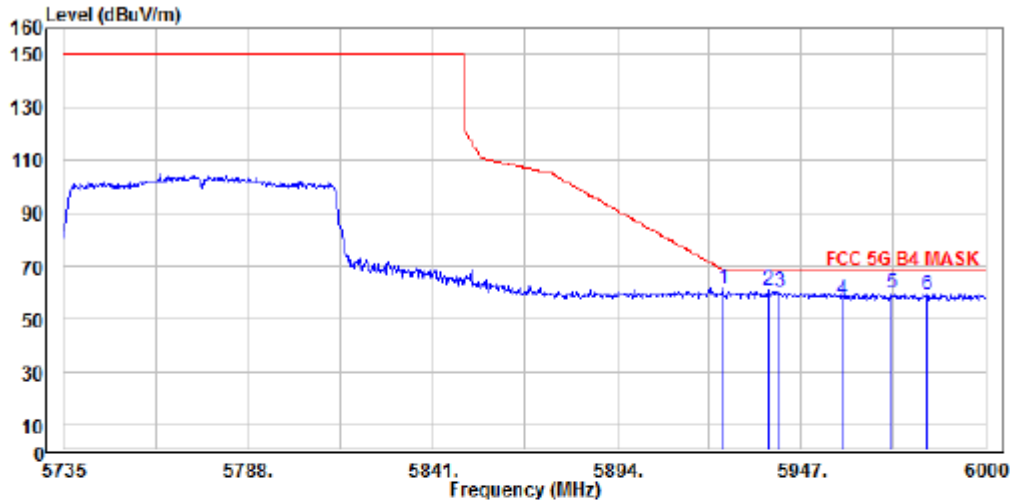

Condition: FCC 5G B4 MASK 3m factor\966 9120D V 1-18G.csv Vertical
 : RBW:1000kHz VBW:1000kHz SWT:Auto DET:Positive
 Mode : 5GHz Band ac80 high ch
 Note :

	Read		Limit	Over		
Freq	Level	Factor	Level	Line	Limit	Pol/Phase
MHz	dBuV	dB/m	dBuV/m	dBuV/m	dB	
1 PP 5924.475	57.13	4.23	61.36	68.59	-7.23	Vertical
2 5937.460	56.43	4.26	60.69	68.20	-7.51	Vertical
3 5940.640	55.88	4.27	60.15	68.20	-8.05	Vertical
4 5958.660	53.12	4.31	57.43	68.20	-10.77	Vertical
5 5973.235	55.35	4.35	59.70	68.20	-8.50	Vertical
6 5983.040	54.91	4.38	59.29	68.20	-8.91	Vertical

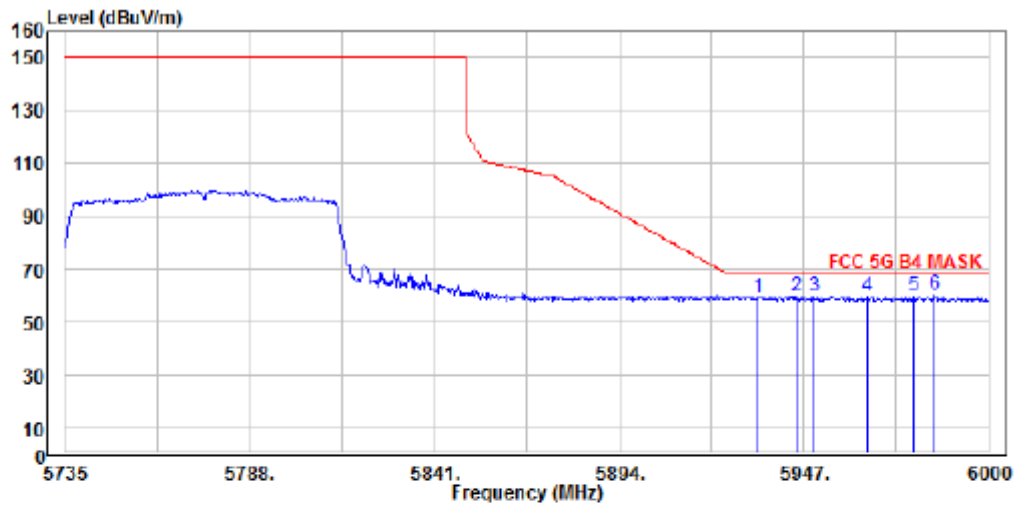

Condition: FCC 5G B4 MASK 3m factor\966 9120D H 1-18G.csv Horizontal
 : RBW:1000kHz VBW:1000kHz SWT:Auto DET:Positive
 Mode : 5GHz Band ac80 high ch
 Note :

	Read		Limit	Over		
Freq	Level	Factor	Level	Line	Limit	Pol/Phase
MHz	dBuV	dB/m	dBuV/m	dBuV/m	dB	
1	5933.750	55.07	4.24	59.31	68.20	-8.89 Horizontal
2	5944.880	55.48	4.28	59.76	68.20	-8.44 Horizontal
3	5950.180	55.32	4.30	59.62	68.20	-8.58 Horizontal
4	5965.285	55.27	4.33	59.60	68.20	-8.60 Horizontal
5	5978.535	55.13	4.36	59.49	68.20	-8.71 Horizontal
6 PP	5984.365	55.58	4.38	59.96	68.20	-8.24 Horizontal

10. Transmission in the Absence of Data

10.1. Standard Applicable

According to §15.407(c)

The device shall automatically discontinue transmission in case of either absence of information to transmit or operational failure. These provisions are not intended to preclude the transmission of control or signaling information or the use of repetitive codes used by certain digital technologies to complete frame or burst intervals. Applicants shall include in their application for equipment authorization a description of how this requirement is met.

10.2. Result:

Pass, the device is compliance with 802.11 a/ b/g/n ac standard, the short control signal is appear during no transmission period.

11. Antenna Requirement

11.1. Standard Applicable

According to §15.203, Antenna requirement.

An intentional radiator shall be designed to ensure that no antenna other than that furnished by the responsible party shall be used with the device. The use of a permanently attached antenna or of an antenna that uses a unique coupling to the intentional radiator shall be considered sufficient to comply with the provisions of this Section. The manufacturer may design the unit so that a broken antenna can be replaced by the user, but the use of a standard antenna jack or electrical connector is prohibited. This requirement does not apply to carrier current devices or to devices operated under the provisions of Sections 15.211, 15.213, 15.217, 15.219, or 15.221. Further, this requirement does not apply to intentional radiators that must be professionally installed, such as perimeter protection systems and some field disturbance sensors, or to other intentional radiators which, in accordance with Section 15.31(d), must be measured at the installation site. However, the installer shall be responsible for ensuring that the proper antenna is employed so that the limits in this Part are not exceeded.

11.2. Antenna Connected Construction

The directional gains of antenna used for transmitting is 3.5 dBi, for Dipole antenna and -1.04 dBi for PIFA antenna which is designed with permanent attachment and no consideration of replacement.

Please see EUT photo for details.

12. TPC and DFS Measurement

12.1. TPC: Standard Applicable

According to §15.407(h)(1), Transmit power control (TPC). U-NII devices operating in the 5.25-5.35 GHz band and the 5.47-5.725 GHz band shall employ a TPC mechanism. The U-NII device is required to have the capability to operate at least 6 dB below the mean EIRP value of 30 dBm. A TPC mechanism is not required for systems with an e.i.r.p. of less than 500 mW.

12.2. DFS: Standard Applicable

According to §15.407(h)(2), Radar Detection Function of Dynamic Frequency Selection (DFS). U-NII devices operating in the 5.25-5.35 GHz and 5.47-5.725 GHz bands shall employ a DFS radar detection.

13.2.1. Limit

Table 1: Applicability of DFS requirements prior to use of a channel

Requirement	Operational Mode		
	Slave	Client(without radar detection)	Client(with radar detection)
Non-occupancy Period	Yes	Not required	Yes
DFS Detection Threshold	Yes	Not required	Yes
Channel Availability Check Time	Yes	Not required	Not required
Uniform Spreading	Yes	Not required	Not required
U-NII Detection Bandwidth	Yes	Not required	Yes

Table 2: Applicability of DFS requirements during normal operation

Requirement	Operational Mode		
	Slave	Client(without radar detection)	Client(with radar detection)
DFS Detection Threshold	Yes	Not required	Yes
Channel Closing Transmission Time	Yes	Yes	Yes
Channel Move Time	Yes	Yes	Yes
U-NII Detection Bandwidth	Yes	Not required	Yes

Refer to KDB Number: 905462 APPENDIX B COMPLIANCE MEASUREMENT PROCEDURES FOR UNLICENSED-NATIONAL INFORMATION INFRASTRUCTURE DEVICES OPERATING IN THE 5.25-5.35 GHz AND 5.47-5.725 GHz BANDS INCORPORATING DYNAMIC FREQUENCY SELECTION.

Table 3: Interference Threshold values, Master or Client incorporating In-Service Monitoring

Maximum Transmit Power	Value (see note)
≥ 200 milliwatt	-64 dBm
< 200 milliwatt	-62 dBm
Note 1: This is the level at the input of the receiver assuming a 0 dBi receive antenna Note 2: Throughout these test procedures an additional 1 dB has been added to the amplitude of the test transmission waveforms to account for variations in measurement equipment. This will ensure that the test signal is at or above the detection threshold level to trigger a DFS response.	

Table 4: DFS Response requirement values

Parameter	Value
<i>Non-occupancy period</i>	Minimum 30 minutes
<i>Channel Availability Check Time</i>	60 seconds
<i>Channel Move Time</i>	10 seconds See Note 1.
<i>Channel Closing Transmission Time</i>	200 milliseconds + an aggregate of 60 milliseconds over remaining 10 second period. See Notes 1 and 2.
<i>U-NII Detection Bandwidth</i>	Minimum 80% of the U-NII 99% transmission power bandwidth. See Note 3.
<p>Note 1: The instant that the <i>Channel Move Time</i> and the <i>Channel Closing Transmission Time</i> begins is as follows:</p> <ul style="list-style-type: none"> • For the Short Pulse Radar Test Signals this instant is the end of the <i>Burst</i>. • For the Frequency Hopping radar Test Signal, this instant is the end of the last radar <i>Burst</i> generated. • For the Long Pulse Radar Test Signal this instant is the end of the 12 second period defining the <i>Radar Waveform</i>. <p>Note 2: The <i>Channel Closing Transmission Time</i> is comprised of 200 milliseconds starting at the beginning of the <i>Channel Move Time</i> plus any additional intermittent control signals required to facilitate a <i>Channel</i> move (an aggregate of 60 milliseconds) during the remainder of the 10 second period. The aggregate duration of control signals will not count quiet periods in between transmissions.</p> <p>Note 3: During the <i>U-NII Detection Bandwidth</i> detection test, radar type 1 is used and for each frequency step the minimum percentage of detection is 90 percent. Measurements are performed with no data traffic.</p>	

Table 5: Radar Test Waveforms

Short Pulse Radar

Radar Type	Pulse Width (μsec)	PRI (μsec)	Number of Pulses	Minimum Percentage of Successful Detection	Minimum Number of Trials
0	1	1428	18	See Note 1	See Note 1
1	1	Test A: 15 unique PRI values randomly selected from the list of 23 PRI values in Table 5a	Roundup $\left\{ \begin{matrix} \left(\frac{1}{360} \right) \cdot \\ \left(\frac{19 \cdot 10^6}{PRI_{\mu sec}} \right) \end{matrix} \right\}$	60%	30
		Test B: 15 unique PRI values randomly selected within the range of 518-3066 μsec, with a minimum increment of 1 μsec, excluding PRI values selected in Test A			
2	1-5	150-230	23-29	60%	30
3	6-10	200-500	16-18	60%	30
4	11-20	200-500	12-16	60%	30
Aggregate (Radar Types 1-4)				80%	120
Note 1: Short Pulse Radar Type 0 should be used for the detection bandwidth test, channel move time, and channel closing time tests.					

A minimum of 30 unique waveforms are required for each of the Short Pulse Radar Types 2 through 4. For Short Pulse Radar Type 1, the same waveform is used a minimum of 30 times. If more than 30 waveforms are used for Short Pulse Radar Types 2 through 4, then each additional waveform must also be unique and not repeated from the previous waveforms

Long Pulse Radar

Radar Type	Pulse Width (μsec)	Chirp Width (MHz)	PRI (μsec)	Number of Pulses per Burst	Number of Bursts	Minimum Percentage of Successful Detection	Minimum Trials
5	50-100	5-20	1000-2000	1-3	8-20	80%	30

The parameters for this waveform are randomly chosen. Thirty unique waveforms are required for the Long Pulse Radar Type waveforms. If more than 30 waveforms are used for the Long Pulse Radar Type waveforms, then each additional waveform must also be unique and not repeated from the previous waveforms.

Frequency Hopping Radar

Radar Type	Pulse Width (μsec)	PRI (μsec)	Pulses per Hop	Hopping Rate (kHz)	Hopping Sequence Length (msec)	Minimum Percentage of Successful Detection	Minimum Trials
6	1	333	9	.333	300	70%	30

For the Frequency Hopping Radar Type, the same *Burst* parameters are used for each waveform. The hopping sequence is different for each waveform and a 100-length segment is selected from the hopping sequence defined by the following algorithm: 3

The first frequency in a hopping sequence is selected randomly from the group of 475 integer frequencies from 5250 – 5724 MHz. Next, the frequency that was just chosen is removed from the group and a frequency is randomly selected from the remaining 474 frequencies in the group. This process continues until all 475 frequencies are chosen for the set. For selection of a random frequency, the frequencies remaining within the group are always treated as equally likely.

13.2.2. Test Setup

Setup for Master with injection at the Master

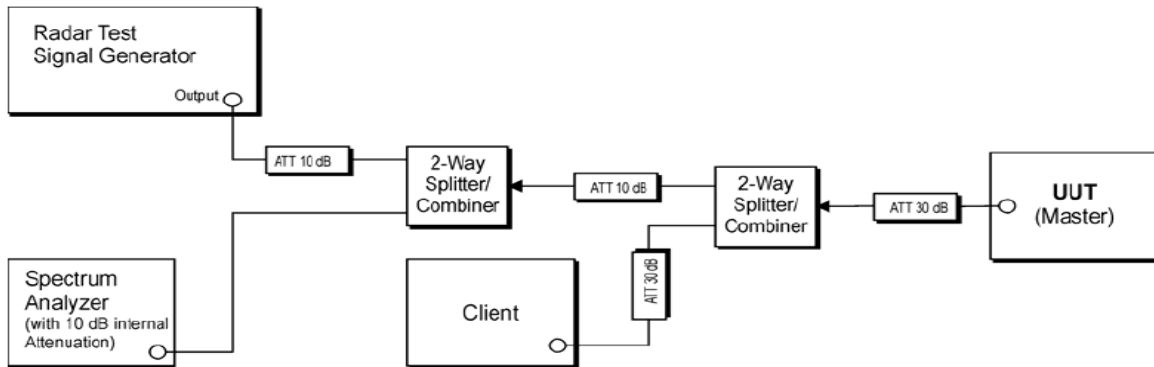

Setup for Client with injection at the Master

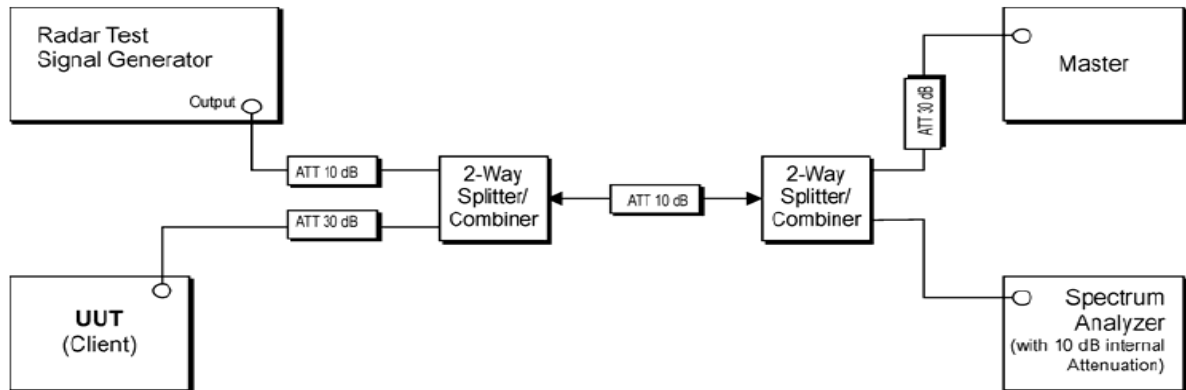

Setup for Client with injection at the Client

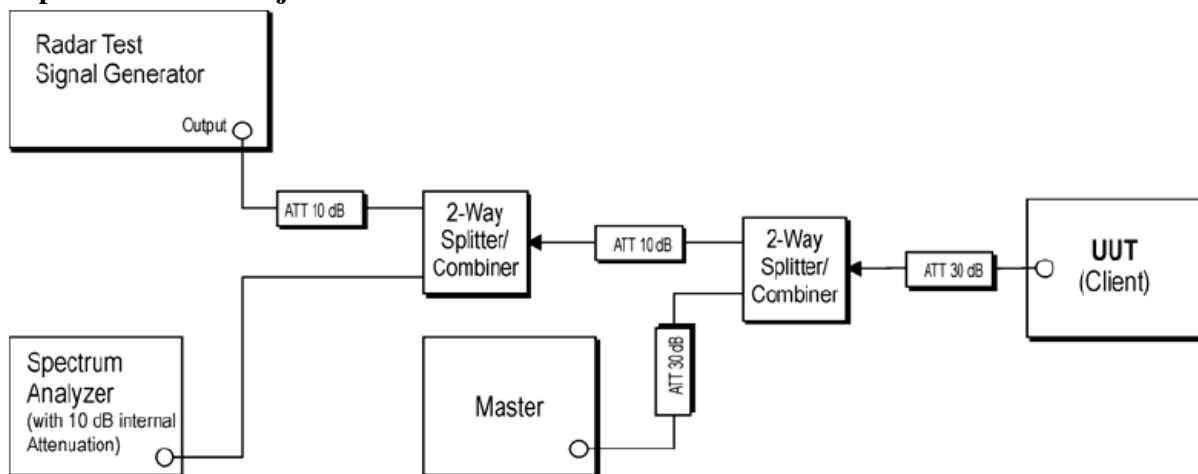

Note: device under test are configured with AP as IP based by streaming MPEG video, 30 frames per seconds

12.3. Test Equipment Used:

Location Conducted	Equipment Name	Brand	Model	S/N	Last Cal. Date	Next Cal. Date
Conducted (DFS)	Signal Generator	Agilent	E4438C	MY49071550	01/16/2020	01/16/2021
Conducted (DFS)	Signal Generator	Agilent	E4438C	MY49071550	01/16/2020	01/16/2021
Conducted (DFS)	Signal Generator	Keysight	N5182B	MY53052399	01/09/2020	01/09/2021
Conducted (DFS)	Signal Generator	Keysight	N5182B	MY53052399	01/09/2020	01/09/2021
Conducted (DFS)	Spectrum analyzer	Keysight	N9010A	MY56070257	10/05/2019	10/05/2020
Conducted (DFS)	AP Router	Synology	Synology RT 1900ac	FTX1220905D	NA	NA
Conducted (DFS)	USB Adapter	D-Link	DWA-182	QBYS1D8000073	NA	NA
Conducted (DFS)	Test Box	Keysight	AD211A	NA	NA	NA
Conducted (DFS)	Test Box	Keysight	AD191A	NA	NA	NA
Conducted (DFS)	Direction Coupler	Krytar	1821S	1461	NA	NA
Conducted (DFS)	Splitter	Mini-Circuits	ZN2PD-63-S	UU97201111	NA	NA
Conducted (DFS)	Attenuator	Woken	Watt-65m3502	11051601	NA	NA
Conducted (DFS)	Software	Agilent	Adaptive TEST	NA	NA	NA
Conducted (DFS)	Cable	Draka	NA	NA	NA	NA
Conducted (DFS)	Test Software	Keysight	N9607B DFS Radar Profiles	NA	NA	NA
Conducted (DFS)	Test Software	Keysight	ETSI Standard test system	NA	NA	NA

12.3.1. Description of EUT :

EUT operates over the 5250-5350MHz and 5470-5725MHz ranges and EUT is a slave device (client equipment) w/o radar detection and DFS capability.

The EUT utilizes the 802.11n architecture, with a nominal channel bandwidth of 80MHz WLAN traffic is generated by streaming the mpeg file from the master to slave in full monitor video mode using the media player.

The rated output power of the master unit is >23dBm(EIRP).therefore the required interference threshold level is -64dBm. The master device as employed for the applicable DFS test is router whose FCC ID= YOR-RT1900AC for Synology

12.4. Test results

Applicability of DFS requirements during normal operation

Requirement	Operational Mode: Client(without radar detection)	
	Test Result	Remark
Non-occupancy Period	No transmission in 30mins. (test results), pass (Remark)	Pass
DFS Detection Threshold	N/A	N/A
Channel Closing Transmission Time	Less than 200ms, Refer to next page for plots.	Pass
Channel Move Time	Less than 10s, Refer to next page for plots.	Pass
U-NII Detection Bandwidth	N/A	N/A

Input Level to Master AP= -64dBm

5250MHz ~ 5350MHz

Radar Type 0 Channel Move & Closing Transmission Time

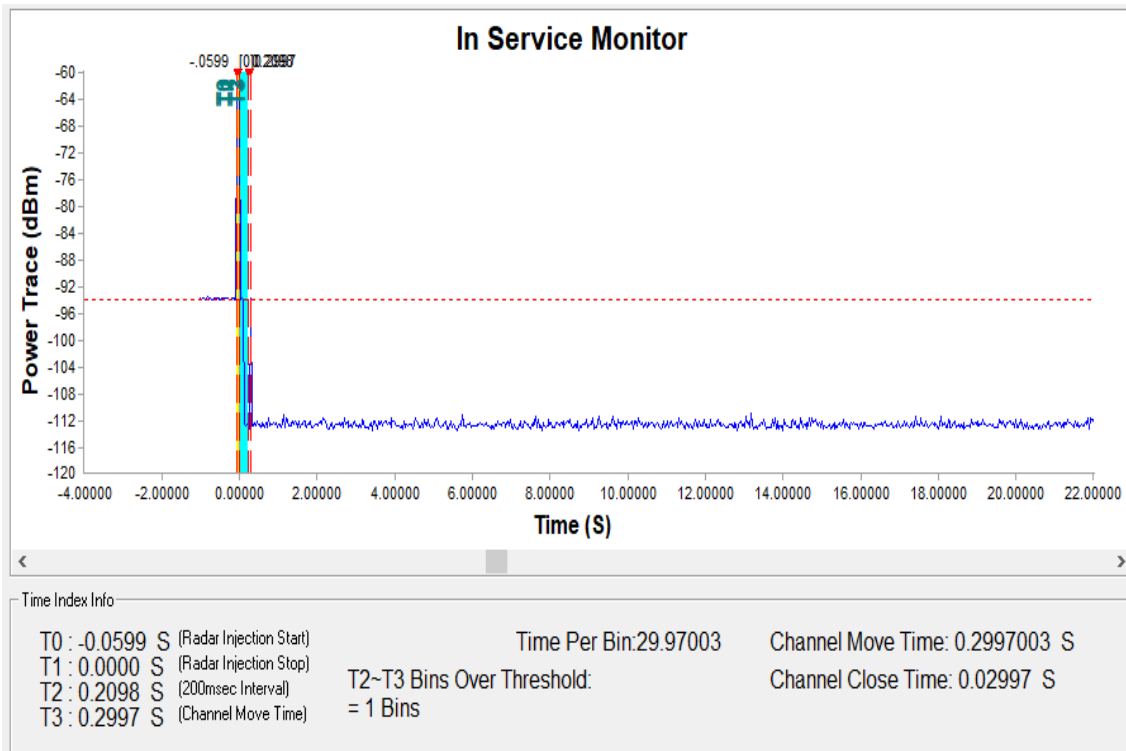

Note: the unit of time per bin is millisecond

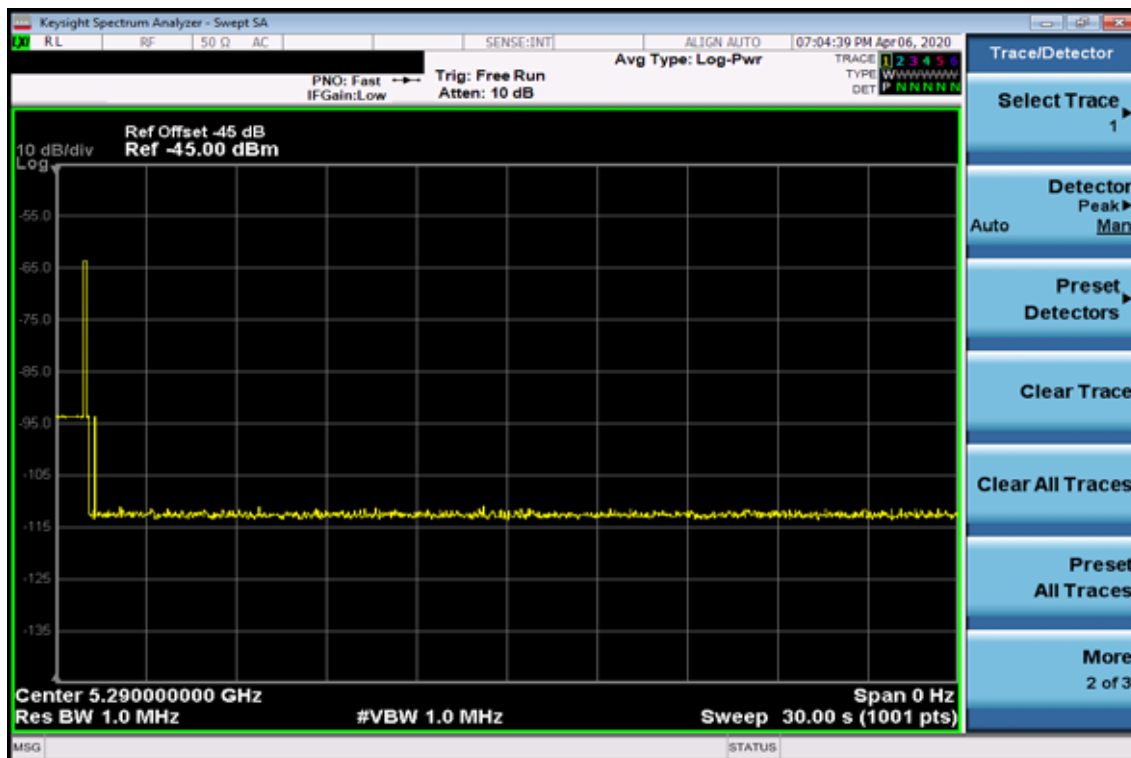

Non-occupancy Period

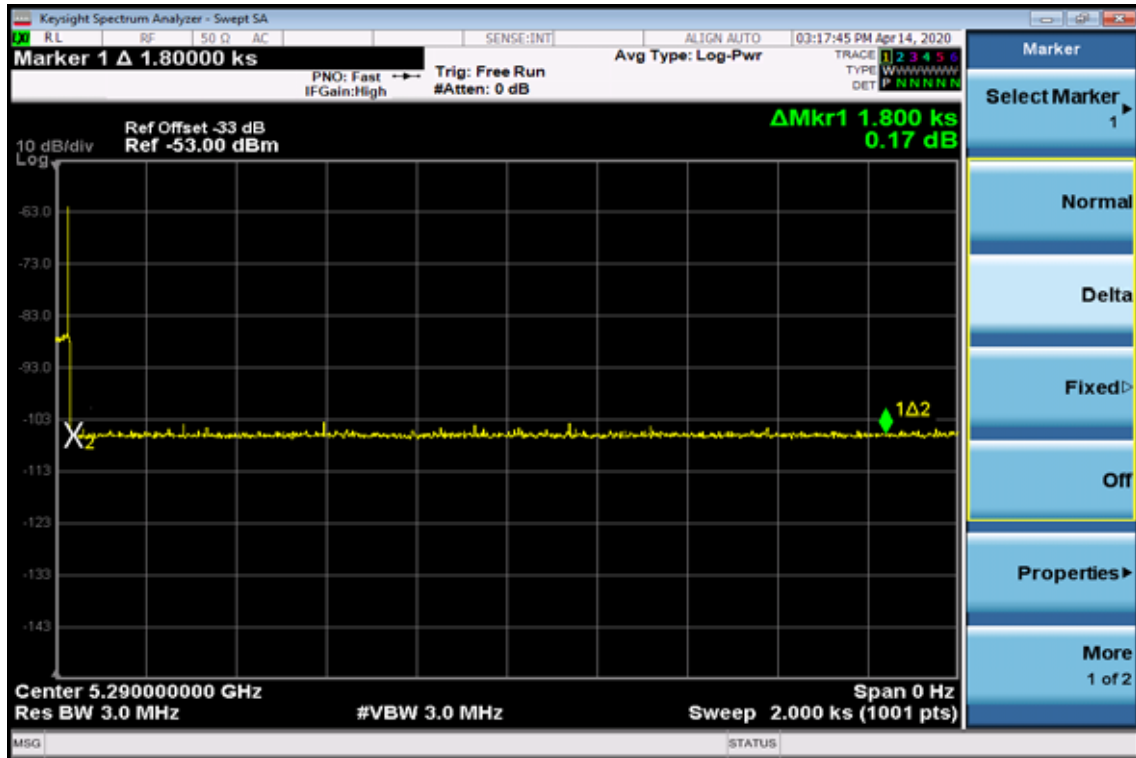

5500MHz ~ 5700MHz

Radar Type 0 Channel Move & Closing Transmission Time

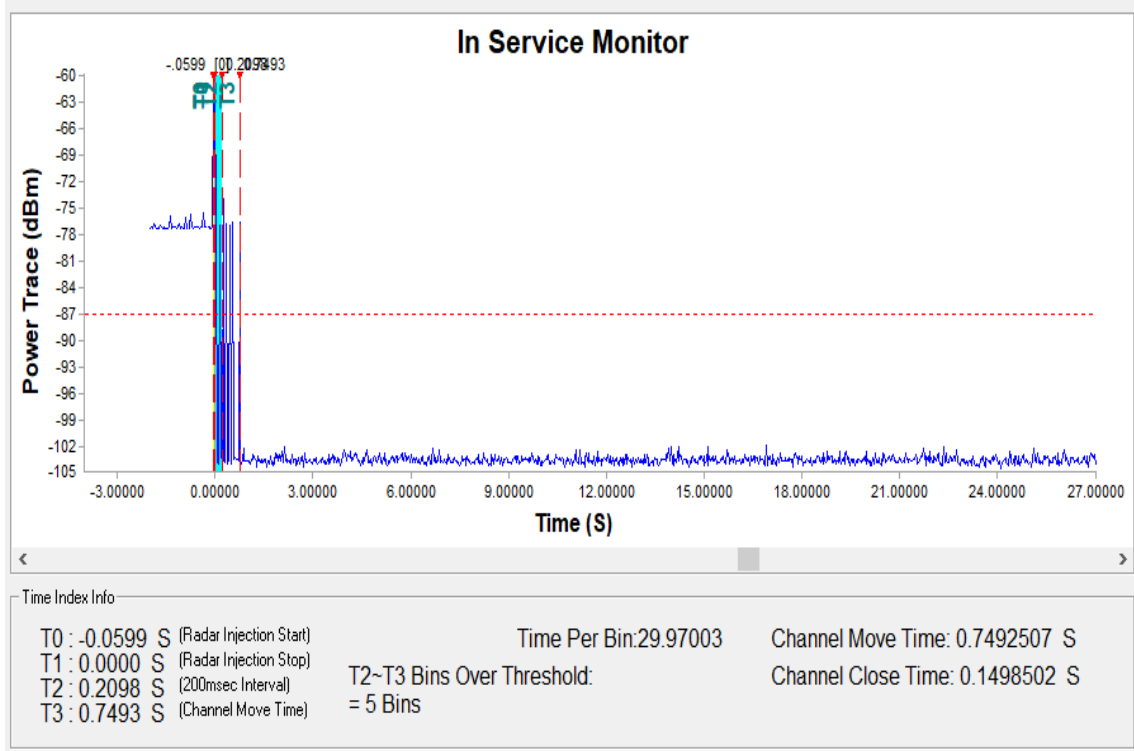

Note: the unit of time per bin is millisecond

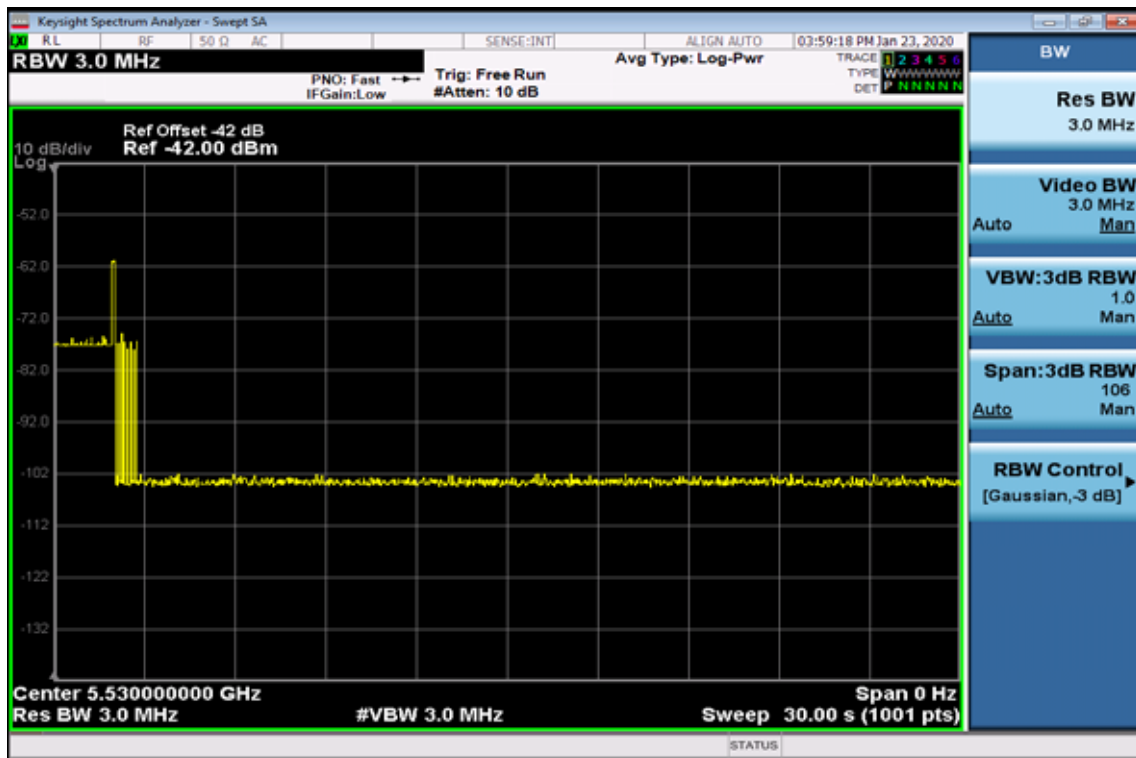

Non-occupancy Period,

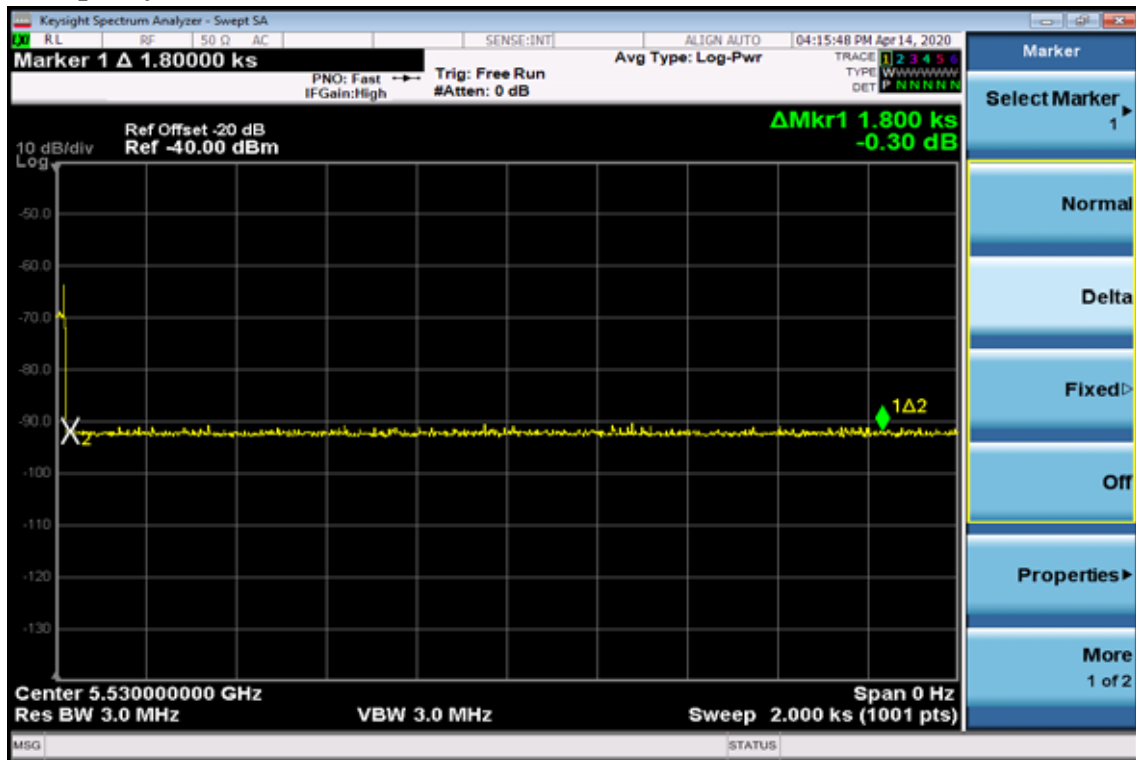

Calibration plots for each of the required radar waveforms

Radar type 0

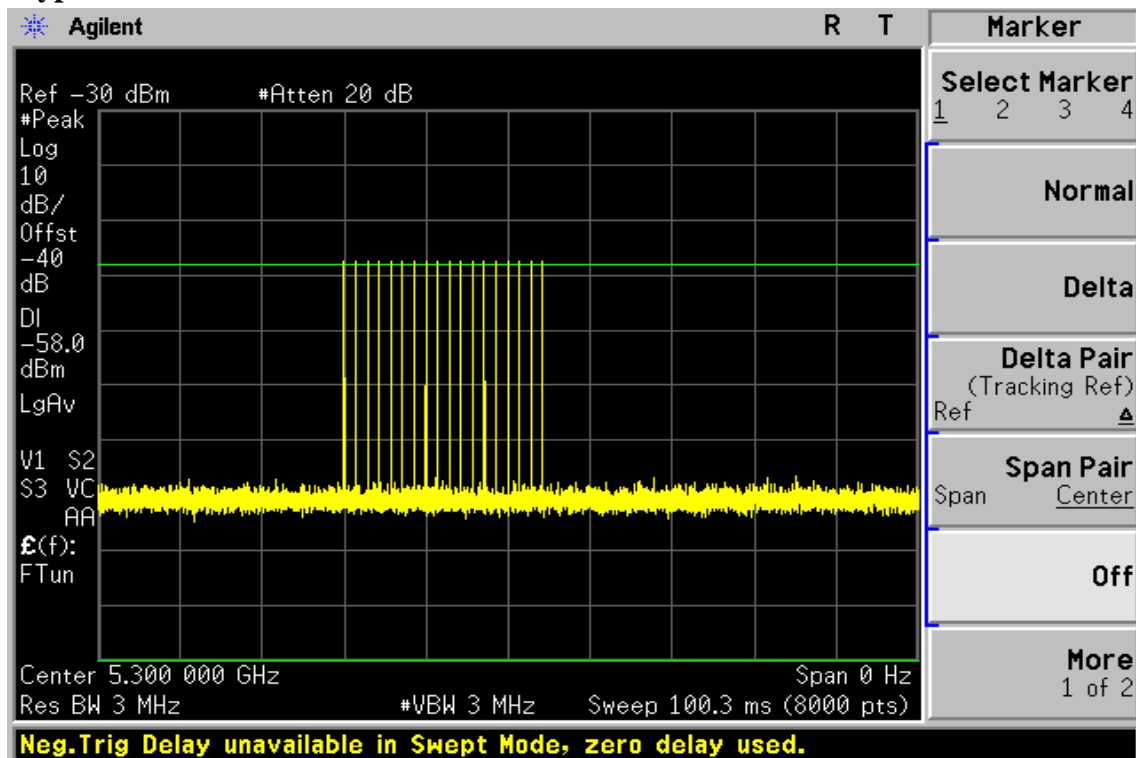

Band 2

WLAN traffic

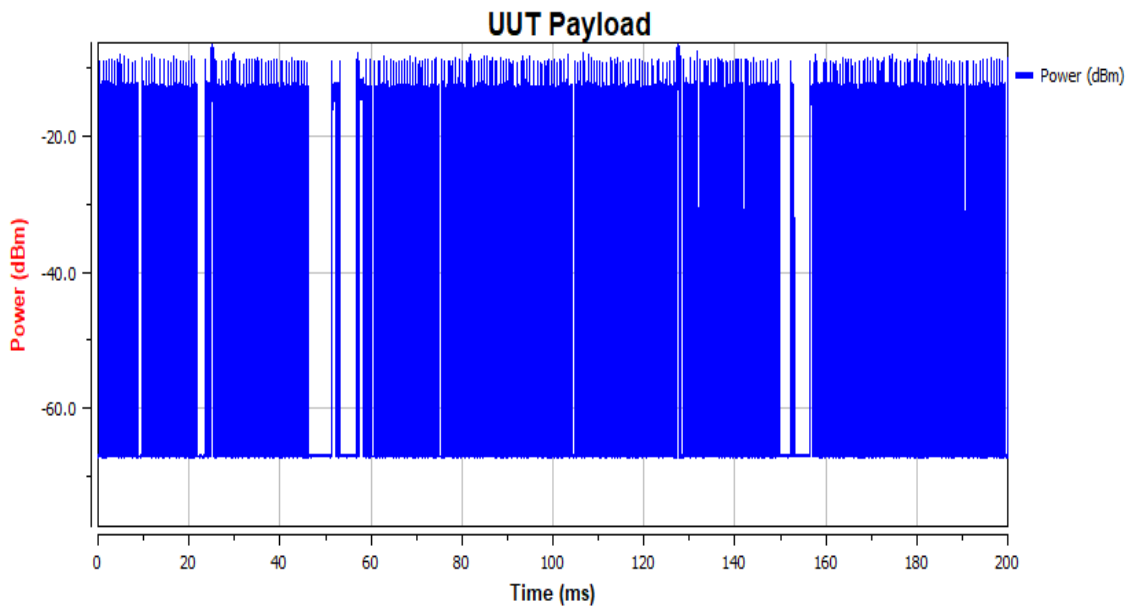

Traffic Load Check Status

Duty Cycle (%) : 58.25

*Please make sure when we want to do the Adaptivity Test, the Duty Cycle in Traffic Load must over then 30%.

Band 3

WLAN traffic

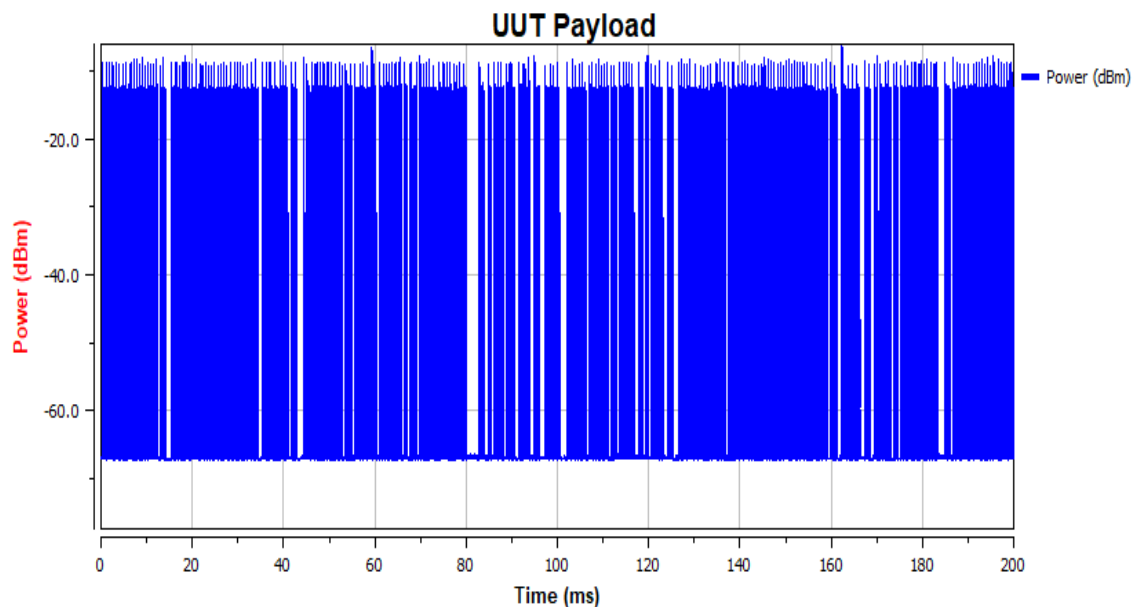

Traffic Load Check Status

Duty Cycle (%) : 55.72

*Please make sure when we want to do the Adaptivity Test, the Duty Cycle in Traffic Load must over then 30%.