

TEST REPORT

Applicant Name: Grandstream Networks, Inc.
Address: 126 Brookline Ave., 3rd Floor Boston, MA 02215, USA
Report Number: 2401U56759E-SAA
FCC ID: YZZWP856

Test Standard (s)

FCC 47 CFR part 2.1093

Sample Description

Product Type: Wi-Fi Smartphone
Model No.: WP856
Multiple Model(s) No.: N/A
Trade Mark: GRANDSTREAM
Serial Number: 2PB0-1
Date Received: 2024/06/18
Date of Test: 2024/08/26~2024/08/29
Issue Date: 2024/09/14

Test Result:

Pass▲

▲ In the configuration tested, the EUT complied with the standards above.

Prepared and Checked By:

Sid Luo

Sid Luo
SAR Engineer

Approved By:

Luke Jiang

Luke Jiang
SAR Engineer

Note: The information marked*is provided by the applicant, the laboratory is not responsible for its authenticity and this information can affect the validity of the result in the test report. Customer model name, addresses, names, trademarks etc. are included.

This report cannot be reproduced except in full, without prior written approval of the Company. Unless otherwise stated the results shown in this test report refer only to the sample(s) tested. This report is valid only with a valid digital signature. The digital signature may be available only under the Adobe software above version 7.0.

This report must not be used by the customer to claim product certification, approval, or endorsement by NVLAP or any agency of the U.S. Government.

This report may contain data that are not covered by the NVLAP accreditation and are marked with an asterisk "▼".

Bay Area Compliance Laboratories Corp. (Shenzhen)

5F(B-West), 6F, 7F, the 3rd Phase of Wan Li Industrial Building D, Shihua Rd, Futian Free Trade Zone, Shenzhen, China
Tel: +86-755-33320018 Fax: +86-755-33320008 www.baclcorp.com.cn

Attestation of Test Results		
Frequency Band	Max. SAR Level(s) Reported(W/kg)	Limit(W/Kg)
2.4G WLAN	1.33W/kg 1g Head SAR 0.43W/kg 1g Body SAR	1.6
5.2G WLAN	1.08W/kg 1g Head SAR 0.66W/kg 1g Body SAR	
5.3G WLAN	1.48W/kg 1g Head SAR 0.92W/kg 1g Body SAR	
5.6G WLAN	1.49W/kg 1g Head SAR 1.20W/kg 1g Body SAR	
5.8G WLAN	1.56W/kg 1g Head SAR 0.82W/kg 1g Body SAR	
5.9G WLAN	1.38W/kg 1g Head SAR 0.54W/kg 1g Body SAR	
Applicable Standards	FCC 47 CFR part 2.1093 Radiofrequency radiation exposure evaluation: portable devices	
	RF Exposure Procedures: TCB Workshop April 2019	
	IEEE1528:2013 IEEE Recommended Practice for Determining the Peak Spatial-Average Specific Absorption Rate (SAR) in the Human Head from Wireless Communications Devices: Measurement Techniques	
	KDB procedures KDB 447498 D01 General RF Exposure Guidance v06 KDB 648474 D04 Handset SAR v01r03 KDB 865664 D01 SAR Measurement 100 MHz to 6 GHz v01r04 KDB 865664 D02 RF Exposure Reporting v01r02 KDB 941225 D06 Hotspot Mode v02r01 KDB 248227 D01 802.11 Wi-Fi SAR v02r02	
<p>Note: This wireless device has been shown to be capable of compliance for localized specific absorption rate (SAR) for General Population/Uncontrolled Exposure limits specified in FCC 47 CFR part 2.1093 and has been tested in accordance with the measurement procedures specified in IEEE 1528-2013 and RF exposure KDB procedures.</p> <p>The results and statements contained in this report pertain only to the device(s) evaluated.</p>		

TABLE OF CONTENTS

DOCUMENT REVISION HISTORY..... 4

EUT DESCRIPTION 5
 TECHNICAL SPECIFICATION..... 5

REFERENCE, STANDARDS, AND GUIDELINES 6
 SAR LIMITS 6

FACILITIES 7

DESCRIPTION OF TEST SYSTEM..... 8

EQUIPMENT LIST AND CALIBRATION..... 15
 EQUIPMENT’S LIST & CALIBRATION INFORMATION 15

SAR MEASUREMENT SYSTEM VERIFICATION 16
 LIQUID VERIFICATION..... 16
 SYSTEM ACCURACY VERIFICATION 18
 SAR SYSTEM VALIDATION DATA 19

EUT TEST STRATEGY AND METHODOLOGY..... 23
 TEST POSITIONS FOR DEVICE OPERATING NEXT TO A PERSON’S EAR 23
 CHEEK/TOUCH POSITION 24
 EAR/TILT POSITION..... 24
 TEST POSITIONS FOR BODY-WORN AND OTHER CONFIGURATIONS 25
 TEST DISTANCE FOR SAR EVALUATION 25
 SAR EVALUATION PROCEDURE 26

CONDUCTED OUTPUT POWER MEASUREMENT 27
 TEST PROCEDURE..... 27
 MAXIMUM TARGET OUTPUT POWER..... 27

STANDALONE SAR TEST EXCLUSION CONSIDERATIONS..... 39
 ANTENNAS LOCATION: 39
 STANDALONE SAR TEST EXCLUSION CONSIDERATIONS 40
 ANTENNA DISTANCE TO EDGE (TRX) 40
 SAR TEST EXCLUSION FOR THE EUT EDGE CONSIDERATIONS RESULT..... 40

SAR MEASUREMENT RESULTS 41
 TEST RESULTS:..... 41

SAR MEASUREMENT VARIABILITY..... 48

SAR SIMULTANEOUS TRANSMISSION DESCRIPTION..... 49

SAR PLOTS 50

APPENDIX A MEASUREMENT UNCERTAINTY 51

APPENDIX B EUT TEST POSITION PHOTOS..... 52

APPENDIX C PROBE CALIBRATION CERTIFICATES 53

DOCUMENT REVISION HISTORY

Revision Number	Report Number	Description of Revision	Date of Revision
0	2401U56759E-SAA	Original Report	2024/09/14

EUT DESCRIPTION

This report has been prepared on behalf of **Grandstream Networks, Inc.** and their product **Wi-Fi Smartphone**, Model: **WP856**, FCC ID: **YZZWP856** or the EUT (Equipment under Test) as referred to in the rest of this report.

**All measurement and test data in this report was gathered from production sample serial number:2PB0-1(Assigned by BACL, Shenzhen). The EUT supplied by the applicant was received on 2024-06-18.*

Technical Specification

Product Type:	Portable
Exposure Category:	Population / Uncontrolled
Antenna Type(s):	Internal Antenna
Hotspot Mode:	Support
Body-Worn Accessories:	None
Face-Head Accessories:	None
Operation modes:	WLAN, Bluetooth, BLE
Frequency Band:	WLAN 2.4G: 2412 -2462 MHz(TX & RX) WLAN 5.2G: 5150 -5250 MHz(TX & RX) WLAN 5.3G: 5250 -5350 MHz(TX & RX) WLAN 5.6G: 5470- 5725 MHz(TX & RX) WLAN 5.8G: 5725 -5850 MHz(TX & RX) WLAN 5.9G: 5725-5850MHz & 5850-5895MHz (TX & RX) Bluetooth: 2402-2480MHz(TX & RX) BLE 1M: 2402-2480MHz (TX & RX) BLE 2M: 2402-2480MHz (TX & RX)
Dimensions (L×W×H):	160 × 75 × 20 mm
Rated Input Voltage:	DC 3.85V from battery
Normal Operation:	Head and Body

REFERENCE, STANDARDS, AND GUIDELINES

FCC:

The Report and Order requires routine SAR evaluation prior to equipment authorization of portable transmitter devices, including portable telephones. For consumer products, the applicable limit is 1.6 mW/g as recommended by the ANSI/IEEE standard C95.1-1992 [6] for an uncontrolled environment (Paragraph 65). According to the Supplement C of OET Bulletin 65 "Evaluating Compliance with FCC Guide-lines for Human Exposure to Radio frequency Electromagnetic Fields", released on Jun 29, 2001 by the FCC, the device should be evaluated at maximum output power (radiated from the antenna) under "worst-case" conditions for normal or intended use, incorporating normal antenna operating positions, device peak performance frequencies and positions for maximum RF energy coupling.

This report describes the methodology and results of experiments performed on wireless data terminal. The objective was to determine if there is RF radiation and if radiation is found, what is the extent of radiation with respect to safety limits. SAR (Specific Absorption Rate) is the measure of RF exposure determined by the amount of RF energy absorbed by human body (or its parts) – to determine how the RF energy couples to the body or head which is a primary health concern for body worn devices. The limit below which the exposure to RF is considered safe by regulatory bodies in North America is 1.6 mW/g average over 1 gram of tissue mass.

SAR Limits

FCC Limit(1g Tissue)

EXPOSURE LIMITS	SAR (W/kg)	
	(General Population / Uncontrolled Exposure Environment)	(Occupational / Controlled Exposure Environment)
Spatial Average (averaged over the whole body)	0.08	0.4
Spatial Peak (averaged over any 1 g of tissue)	1.6	8.0
Spatial Peak (hands/wrists/feet/ankles averaged over 10 g)	4.0	20.0

Population/Uncontrolled Environments are defined as locations where there is the exposure of individual who have no knowledge or control of their exposure.

Occupational/Controlled Environments are defined as locations where there is exposure that maybe incurred by people who are aware of the potential for exposure (i.e. as a result of employment or occupation).

General Population/Uncontrolled environments Spatial Peak limit 1.6W/kg for 1g SAR applied to the EUT.

FACILITIES

The test site used by Bay Area Compliance Laboratories Corp. (Shenzhen) to collect data is located at 5F(B-West) ,6F,7F,the 3rd Phase of Wan Li Industrial Building D,Shihua Rd, FuTian Free Trade Zone, Shenzhen, China

The lab has been recognized as the FCC accredited lab under the KDB 974614 D01 and is listed in the FCC Public Access Link (PAL) database, FCC Registration No.: 715558, the FCC Designation No.: CN5045.

Each test item follows test standards and with no deviation.

DESCRIPTION OF TEST SYSTEM

These measurements were performed with the automated near-field scanning system DASY6 from Schmid & Partner Engineering AG (SPEAG) which is the Fifth generation of the system shown in the figure hereinafter:

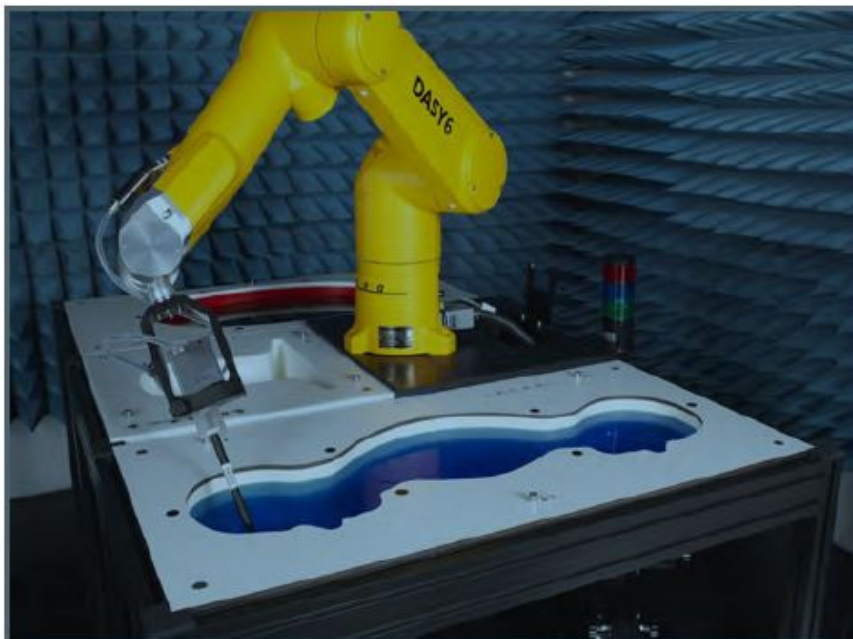

DASY6 System Description

The DASY6 system for performing compliance tests consists of the following items:

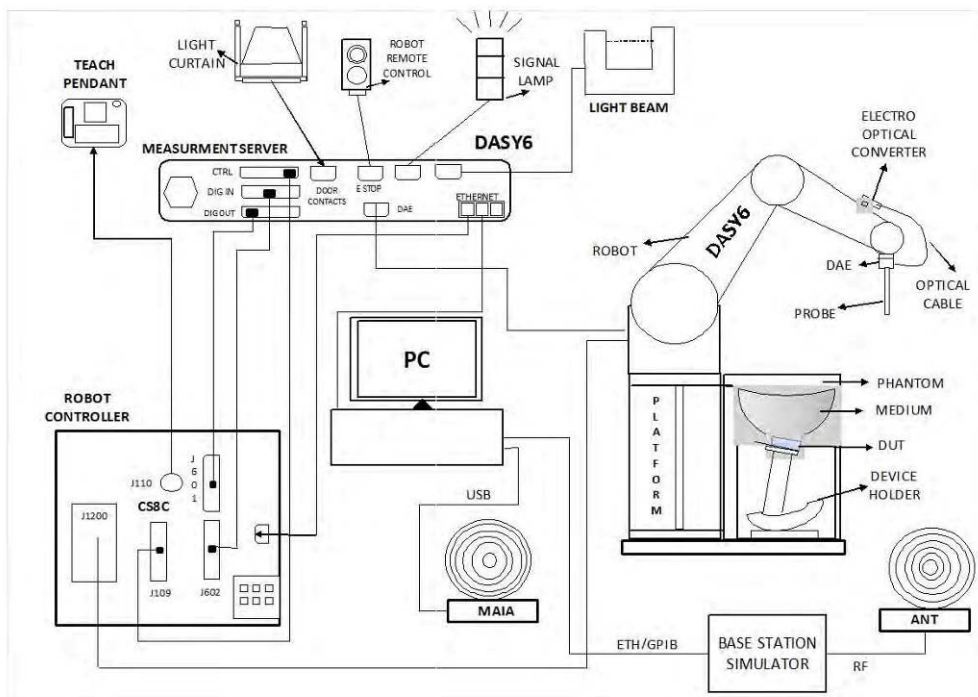

- A standard high precision 6-axis robot (Staubli TX=RX family) with controller, teach pendant and software. An arm extension for accommodating the data acquisition electronics (DAE).
- An isotropic field probe optimized and calibrated for the targeted measurement.
- A data acquisition electronics (DAE) which performs the signal application, signal multiplexing, AD-conversion, offset measurements, mechanical surface detection, collision detection, etc. The unit is battery powered with standard or rechargeable batteries. The signal is optically transmitted to the EOC.
- The Electro-optical converter (EOC) performs the conversion from optical to electrical signals for the digital communication to the DAE. To use optical surface detection, a special version of the EOC is required. The EOC signal is transmitted to the measurement server.
- The function of the measurement server is to perform the time critical tasks such as signal filtering, control of the robot operation and fast movement interrupts.
- The Light Beam used is for probe alignment. This improves the (absolute) accuracy of the probe positioning.
- A computer running Win7 professional operating system and the DASY52 software.
- Remote control and teach pendant as well as additional circuitry for robot safety such as warning lamps, etc.
- The phantom, the device holder and other accessories according to the targeted measurement.

DASY6 Measurement Server

The DASY6 measurement server is based on a PC/104 CPU board with a 400 MHz Intel ULV Celeron, 128 MB chip-disk and 128 MB RAM. The necessary circuits for communication with the DAE4 (or DAE3) electronics box, as well as the 16-bit AD converter system for optical detection and digital I/O interface are contained on the DASY6 I/O board, which is directly connected to the PC/104 bus of the CPU board.



The measurement server performs all real-time data evaluations of field measurements and surface detection, controls robot movements, and handles safety operations. The PC operating system cannot interfere with these time-critical processes. All connections are supervised by a watchdog, and disconnection of any of the cables to the measurement server will automatically disarm the robot and disable all program- controlled robot movements. Furthermore, the measurement server is equipped with an expansion port, which is reserved for future applications. Please note that this expansion port does not have a standardized pinout, and therefore only devices provided by SPEAG can be connected. Connection of devices from any other supplier could seriously damage the measurement server.

Data Acquisition Electronics

The data acquisition electronics (DAE4) consist of a highly sensitive electrometer-grade preamplifier with auto-zeroing, a channel and gain-switching multiplexer, a fast 16 bit AD-converter and a command decoder with a control logic unit. Transmission to the measurement server is accomplished through an optical downlink for data and status information, as well as an optical uplink for commands and the clock.

The mechanical probe mounting device includes two different sensor systems for frontal and sideways probe contacts. They are used for mechanical surface detection and probe collision detection.

The input impedance of both the DAE4 as well as of the DAE3 box is 200M Ω ; the inputs are symmetrical and floating. Common mode rejection is above 80 dB.

EX3DV4 E-Field Probes

Frequency	4 MHz to >10 GHz Linearity: ± 0.2 dB (30 MHz to 10 GHz)
Directivity	± 0.1 dB in TSL (rotation around probe axis) ± 0.3 dB in TSL (rotation normal to probe axis)
Dynamic Range	10 µW/g to > 100 mW/g Linearity: ± 0.2 dB (noise: typically < 1 µW/g)
Dimensions	Overall length: 337 mm (Tip: 20 mm) Tip diameter: 2.5 mm (Body: 12 mm) Typical distance from probe tip to dipole centers: 1 mm
Application	High precision dosimetric measurements in any exposure scenario (e.g., very strong gradient fields); the only probe that enables compliance testing for frequencies up to 6 GHz with precision of better 30%.
Compatibility	DASY3, DASY4, DASY52 SAR and higher, EASY6, EASY4/MRI

SAM Twin Phantom

The SAM Twin Phantom (shown in front of DASY6) is a fiberglass shell phantom with shell thickness 2 mm, except in the ear region where the thickness is increased to 6 mm. The phantom has three measurement areas: 1) Left Head, 2) Right Head, and 3) Flat Section. For larger devices, the use of the ELI-Phantom (shown behind DASY6) is required. For devices such as glasses with a wireless link, the Face Down Phantom is the most suitable (between the SAM Twin and ELI phantoms).

When the phantom is mounted inside allocated slot of the DASY6 platform, phantom reference points can be taught directly in the DASY5 V5.2 software. When the DASY6 platform is used to mount the

Phantom, some of the phantom teaching points cannot be reached by the robot in DASY5 V5.2. A special tool called P1a-P2aX-Former is provided to transform two of the three points, P1 and P2, to reachable locations. To use these new teaching points, a revised phantom configuration file is required.

In addition to our standard broadband liquids, the phantom can be used with the following tissue simulating liquids:

Sugar-water-based liquids can be left permanently in the phantom. Always cover the liquid when the system is not in use to prevent changes in liquid parameters due to water evaporation.

DGBE-based liquids should be used with care. As DGBE is a softener for most plastics, the liquid should be taken out of the phantom, and the phantom should be dried when the system is not in use (desirable at least once a week).

Do not use other organic solvents without previously testing the solvent resistivity of the phantom. Approximately 25 liters of liquid is required to fill the SAM Twin phantom.

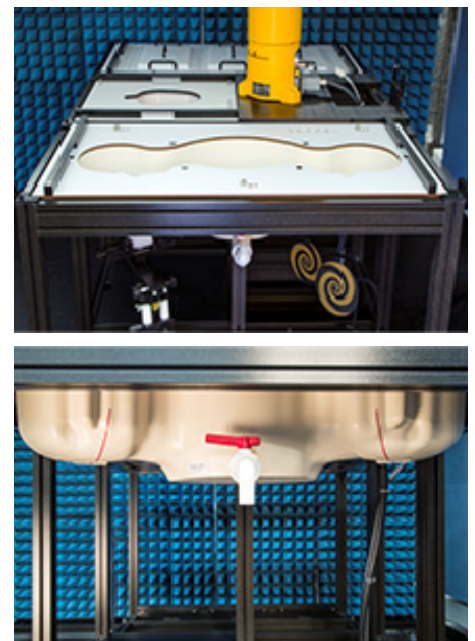

ELI Phantom

The ELI phantom is intended for compliance testing of handheld and body-mounted wireless devices in the frequency range of 30MHz to 6 GHz. ELI is fully compatible with the latest draft of the standard IEEE1528 and the use of all known tissue simulating liquids. ELI has been optimized for performance and can be integrated into a SPEAG standard phantom table. A cover is provided to prevent evaporation of water and changes in liquid parameters. Reference markings on the phantom allow installation of the complete setup, including all predefined phantom positions and measurement grids, by teaching three points.

The phantom can be used with the following tissue simulating liquids:

- Sugar-water-based liquids can be left permanently in the phantom. Always cover the liquid when the system is not in use to prevent changes in liquid parameters due to water evaporation.
- DGBE-based liquids should be used with care. As DGBE is a softener for most plastics, the liquid should be taken out of the phantom, and the phantom should be dried when the system is not in use (desirable at least once a week).
- Do not use other organic solvents without previously testing the solvent resistivity of the phantom.

Approximately 25 liters of liquid is required to fill the ELI phantom.

Robots

The DASY6 system uses the high-precision industrial robots TX60L, TX90XL, and RX160L from Staubli SA (France). The TX robot family - the successor of the well-known RX robot family - continues to offer the features important for DASY6 applications:

- High precision (repeatability 0.02mm)
- High reliability (industrial design)
- Low maintenance costs (virtually maintenance free due to direct drive gears; no belt drives)
- Jerk-free straight movements (brushless synchrony motors; no stepper motors)
- Low ELF interference (motor control fields shielded via the closed metallic construction shields)

The robots are controlled by the Staubli CS8c robot controllers. All information regarding the use and maintenance of the robot arm and the robot controller is provided

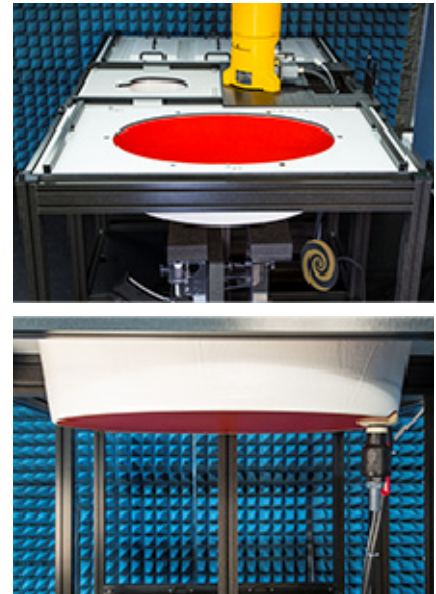

Calibration Frequency Points for EX3DV4 E-Field Probes SN: 7382 Calibrated: 2023/09/27

Calibration Frequency Point (MHz)	Frequency Range (MHz)		Conversion Factor		
	From	To	X	Y	Z
750 Head	650	850	10.65	10.65	10.65
900 Head	850	1000	10.19	10.19	10.19
1750 Head	1650	1850	8.60	8.60	8.60
1900 Head	1850	2000	8.30	8.30	8.30
2300 Head	2200	2400	8.16	8.16	8.16
2450 Head	2400	2550	7.89	7.89	7.89
2600 Head	2550	2700	7.65	7.65	7.65
3300 Head	3200	3400	7.39	7.39	7.39
3500 Head	3400	3600	7.24	7.24	7.24
3700 Head	3600	3800	7.10	7.10	7.10
3900 Head	3800	4000	6.98	6.98	6.98
5250 Head	5140	5360	5.62	5.62	5.62
5500 Head	5390	5610	5.10	5.10	5.10
5750 Head	5640	5860	5.08	5.08	5.08

SAR Scan Procedures

Step 1: Power Reference Measurement

The Power Reference Measurement and Power Drift Measurements are for monitoring the power drift of the device under test in the batch process. The minimum distance of probe sensors to surface determines the closest measurement point to phantom surface. The minimum distance of probe sensors to surface is 1.4 mm. This distance cannot be smaller than the distance of sensor calibration points to probe tip as defined in the probe properties.

Step 2: Area Scans

Area scans are defined prior to the measurement process being executed with a user defined variable spacing between each measurement point (integral) allowing low uncertainty measurements to be conducted. Scans defined for FCC applications utilize a 15mm² step integral, with 1.5mm interpolation used to locate the peak SAR area used for zoom scan assessments.

Where the system identifies multiple SAR peaks (which are within 25% of peak value) the system will provide the user with the option of assessing each peak location individually for zoom scan averaging.

Area Scan Parameters extracted from KDB 865664 D01 SAR Measurement 100 MHz to 6 GHz

	≤ 3 GHz	> 3 GHz
Maximum distance from closest measurement point (geometric center of probe sensors) to phantom surface	5 mm ± 1 mm	$\frac{1}{2} \cdot \delta \cdot \ln(2)$ mm ± 0.5 mm
Maximum probe angle from probe axis to phantom surface normal at the measurement location	30° ± 1°	20° ± 1°
Maximum area scan spatial resolution: Δx_{Area} , Δy_{Area}	≤ 2 GHz: ≤ 15 mm 2 – 3 GHz: ≤ 12 mm	3 – 4 GHz: ≤ 12 mm 4 – 6 GHz: ≤ 10 mm
	When the x or y dimension of the test device, in the measurement plane orientation, is smaller than the above, the measurement resolution must be ≤ the corresponding x or y dimension of the test device with at least one measurement point on the test device.	

Step 3: Zoom Scan (Cube Scan Averaging)

The averaging zoom scan volume utilized in the DASY5 software is in the shape of a cube and the side dimension of a 1 g or 10 g mass is dependent on the density of the liquid representing the simulated tissue. A density of 1000 kg/m³ is used to represent the head and body tissue density and not the phantom liquid density, in order to be consistent with the definition of the liquid dielectric properties, i.e. the side length of the 1g cube is 5mm, with the side length of the 10g cube is 21.5mm.

Zoom Scan Parameters extracted from KDB 865664 D01 SAR Measurement 100 MHz to 6 GHz

Maximum zoom scan spatial resolution: $\Delta x_{Zoom}, \Delta y_{Zoom}$		≤ 2 GHz: ≤ 8 mm 2 – 3 GHz: ≤ 5 mm*	3 – 4 GHz: ≤ 5 mm* 4 – 6 GHz: ≤ 4 mm*
Maximum zoom scan spatial resolution, normal to phantom surface	uniform grid: $\Delta z_{Zoom}(n)$	≤ 5 mm	3 – 4 GHz: ≤ 4 mm 4 – 5 GHz: ≤ 3 mm 5 – 6 GHz: ≤ 2 mm
	graded grid	$\Delta z_{Zoom}(1)$: between 1 st two points closest to phantom surface	≤ 4 mm
		$\Delta z_{Zoom}(n>1)$: between subsequent points	$\leq 1.5 \cdot \Delta z_{Zoom}(n-1)$ mm
Minimum zoom scan volume	x, y, z	≥ 30 mm	3 – 4 GHz: ≥ 28 mm 4 – 5 GHz: ≥ 25 mm 5 – 6 GHz: ≥ 22 mm
<p>Note: δ is the penetration depth of a plane-wave at normal incidence to the tissue medium; see IEEE Std 1528-2013 for details.</p> <p>* When zoom scan is required and the <i>reported</i> SAR from the <i>area scan based 1-g SAR estimation</i> procedures of KDB Publication 447498 is ≤ 1.4 W/kg, ≤ 8 mm, ≤ 7 mm and ≤ 5 mm zoom scan resolution may be applied, respectively, for 2 GHz to 3 GHz, 3 GHz to 4 GHz and 4 GHz to 6 GHz.</p>			

Step 4: Power Drift Measurement

The Power Drift Measurement measures the field at the same location as the most recent power reference measurement within the same procedure, and with the same settings. The Power Drift Measurement gives the field difference in dB from the reading conducted within the last Power Reference Measurement. This allows a user to monitor the power drift of the device under test within a batch process. The measurement procedure is the same as Step 1.

When the cube intersects with the surface of the phantom, it is oriented so that 3 vertices touch the surface of the shell or the center of a face is tangent to the surface. The face of the cube closest to the surface is modified in order to conform to the tangent surface.

The zoom scan integer steps can be user defined so as to reduce uncertainty, but normal practice for typical test applications (including FCC) utilize a physical step of 7 x7 x 7 (5mmx5mmx5mm) providing a volume of 30 mm in the X & Y & Z axis.

Tissue Dielectric Parameters for Head and Body Phantoms

The head tissue dielectric parameters recommended by the IEEE1528:2013

Recommended Tissue Dielectric Parameters for Head liquid

Table A.3 – Dielectric properties of the head tissue-equivalent liquid

Frequency MHz	Relative permittivity ϵ_r	Conductivity (σ) S/m
300	45,3	0,87
450	43,5	0,87
<i>750</i>	<i>41,9</i>	<i>0,89</i>
835	41,5	0,90
900	41,5	0,97
1 450	40,5	1,20
<i>1 500</i>	<i>40,4</i>	<i>1,23</i>
<i>1 640</i>	<i>40,2</i>	<i>1,31</i>
<i>1 750</i>	<i>40,1</i>	<i>1,37</i>
1 800	40,0	1,40
1 900	40,0	1,40
2 000	40,0	1,40
<i>2 100</i>	<i>39,8</i>	<i>1,49</i>
<i>2 300</i>	<i>39,5</i>	<i>1,67</i>
2 450	39,2	1,80
<i>2 600</i>	<i>39,0</i>	<i>1,96</i>
3 000	38,5	2,40
<i>3 500</i>	<i>37,9</i>	<i>2,91</i>
<i>4 000</i>	<i>37,4</i>	<i>3,43</i>
<i>4 500</i>	<i>36,8</i>	<i>3,94</i>
<i>5 000</i>	<i>36,2</i>	<i>4,45</i>
<i>5 200</i>	<i>36,0</i>	<i>4,66</i>
<i>5 400</i>	<i>35,8</i>	<i>4,86</i>
<i>5 600</i>	<i>35,5</i>	<i>5,07</i>
<i>5 800</i>	<i>35,3</i>	<i>5,27</i>
<i>6 000</i>	<i>35,1</i>	<i>5,48</i>

NOTE For convenience, permittivity and conductivity values at those frequencies which are not part of the original data provided by Drossos et al. [33] or the extension to 5 800 MHz are provided (i.e. the values shown *in italics*). These values were linearly interpolated between the values in this table that are immediately above and below these values, except the values at 6 000 MHz that were linearly extrapolated from the values at 3 000 MHz and 5 800 MHz.

EQUIPMENT LIST AND CALIBRATION

Equipment's List & Calibration Information

Equipment	Model	S/N	Calibration Date	Calibration Due Date
DASY5 Test Software	DASY52 52.10.2	N/A	NCR	NCR
DASY6 Measurement Server	DASY6 6.0.31	N/A	NCR	NCR
Data Acquisition Electronics	DAE4	1325	2023/09/27	2024/09/26
E-Field Probe	EX3DV4	7382	2023/09/27	2024/09/26
Mounting Device	MD4HHTV5	SD 000 H01 KA	NCR	NCR
SAM Twin Phantom	SAM-Twin V8.0	1962	NCR	NCR
Dipole, 2450MHz	D2450V2	1103	2023/03/27	2026/03/26
Dipole,5GHz	D5GHzV2	1374	2023/03/27	2026/03/26
Simulated Tissue Liquid Head	HBBL600-10000V6	2200808-2	Each Time	/
Network Analyzer	E5071C	SER MY46519680	2024/05/21	2025/05/20
Dielectric Assessment Kit	DAK-3.5	1248	NCR	NCR
MXG Analog Signal Generator	N5181A	MY48180408	2024/01/16	2025/01/15
USB wideband power sensor	U2021XA	MY52350001	2024/05/21	2025/05/20
RF Power Amplifier	5205FE	1014	NCR	NCR
Directional Coupler	855673	3307	NCR	NCR
20dB Attenuator	2	BH9879	NCR	NCR
Amplifier	ZVE-8G+	558401902	NCR	NCR
Thermometer	DTM3000	N/A	2024/01/16	2025/01/15
Temperature & Humidity Meter	10316377	N/A	2024/01/17	2025/01/16
Spectrum Analyzer	FSV40	101942	2023/12/18	2024/12/17

NCR: No Calibration Required.

SAR MEASUREMENT SYSTEM VERIFICATION

Liquid Verification

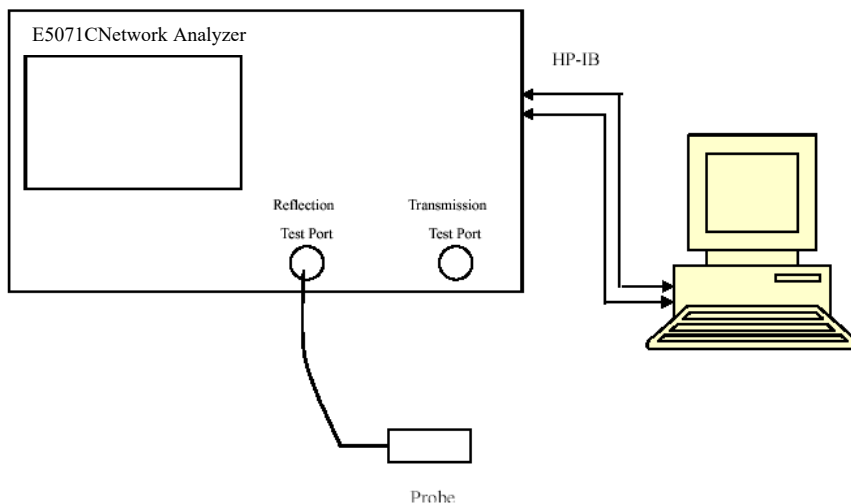

Liquid Verification Setup Block Diagram

Liquid Verification Results

Frequency (MHz)	Liquid Type	Liquid Parameter		Target Value		Delta (%)		Tolerance (%)
		ϵ_r	σ (S/m)	ϵ_r	σ (S/m)	$\Delta\epsilon_r$	$\Delta\sigma$	
2412	Simulated Tissue Liquid Head	39.240	1.714	39.27	1.77	-0.08	-3.16	±5
2437	Simulated Tissue Liquid Head	39.144	1.752	39.22	1.79	-0.19	-2.12	±5
2450	Simulated Tissue Liquid Head	39.095	1.772	39.20	1.80	-0.27	-1.56	±5
2462	Simulated Tissue Liquid Head	39.049	1.790	39.18	1.81	-0.33	-1.10	±5

*Liquid Verification was performed on 2024/08/26.

Frequency (MHz)	Liquid Type	Liquid Parameter		Target Value		Delta (%)		Tolerance (%)
		ϵ_r	σ (S/m)	ϵ_r	σ (S/m)	$\Delta\epsilon_r$	$\Delta\sigma$	
5180	Simulated Tissue Liquid Head	34.657	4.633	36.02	4.64	-3.78	-0.15	±5
5200	Simulated Tissue Liquid Head	34.638	4.656	36.00	4.66	-3.78	-0.09	±5
5240	Simulated Tissue Liquid Head	34.600	4.703	35.96	4.70	-3.78	0.06	±5
5250	Simulated Tissue Liquid Head	34.590	4.715	35.95	4.71	-3.78	0.11	±5
5260	Simulated Tissue Liquid Head	34.581	4.727	35.94	4.72	-3.78	0.15	±5
5280	Simulated Tissue Liquid Head	34.562	4.750	35.92	4.74	-3.78	0.21	±5
5320	Simulated Tissue Liquid Head	34.524	4.797	35.88	4.78	-3.78	0.36	±5

*Liquid Verification was performed on 2024/08/27.

Frequency (MHz)	Liquid Type	Liquid Parameter		Target Value		Delta (%)		Tolerance (%)
		ϵ_r	σ (S/m)	ϵ_r	σ (S/m)	$\Delta\epsilon_r$	$\Delta\sigma$	
5500	Simulated Tissue Liquid Head	34.840	4.896	35.65	4.97	-2.27	-1.49	±5
5580	Simulated Tissue Liquid Head	34.736	4.946	35.53	5.05	-2.23	-2.06	±5
5600	Simulated Tissue Liquid Head	34.710	4.959	35.50	5.07	-2.23	-2.19	±5

*Liquid Verification was performed on 2024/08/28.

Frequency (MHz)	Liquid Type	Liquid Parameter		Target Value		Delta (%)		Tolerance (%)
		ϵ_r	σ (S/m)	ϵ_r	σ (S/m)	$\Delta\epsilon_r$	$\Delta\sigma$	
5720	Simulated Tissue Liquid Head	35.438	5.067	35.38	5.19	0.16	-2.37	±5
5755	Simulated Tissue Liquid Head	35.383	5.135	35.35	5.23	0.09	-1.82	±5
5795	Simulated Tissue Liquid Head	35.320	5.212	35.31	5.27	0.03	-1.10	±5
5800	Simulated Tissue Liquid Head	35.312	5.222	35.30	5.27	0.03	-0.91	±5
5815	Simulated Tissue Liquid Head	35.289	5.251	35.29	5.29	0.00	-0.74	±5

*Liquid Verification was performed on 2024/08/29.

System Accuracy Verification

Prior to the assessment, the system validation kit was used to test whether the system was operating within its specifications of $\pm 10\%$. The validation results are tabulated below. And also the corresponding SAR plot is attached as well in the SAR plots files.

The spacing distances in the **System Verification Setup Block Diagram** is given by the following:

- a) $s = 15 \text{ mm} \pm 0,2 \text{ mm}$ for $300 \text{ MHz} \leq f \leq 1 \text{ 000 MHz}$;
- b) $s = 10 \text{ mm} \pm 0,2 \text{ mm}$ for $1 \text{ 000 MHz} < f \leq 3 \text{ 000 MHz}$;
- c) $s = 10 \text{ mm} \pm 0,2 \text{ mm}$ for $3 \text{ 000 MHz} < f \leq 6 \text{ 000 MHz}$.

System Verification Setup Block Diagram

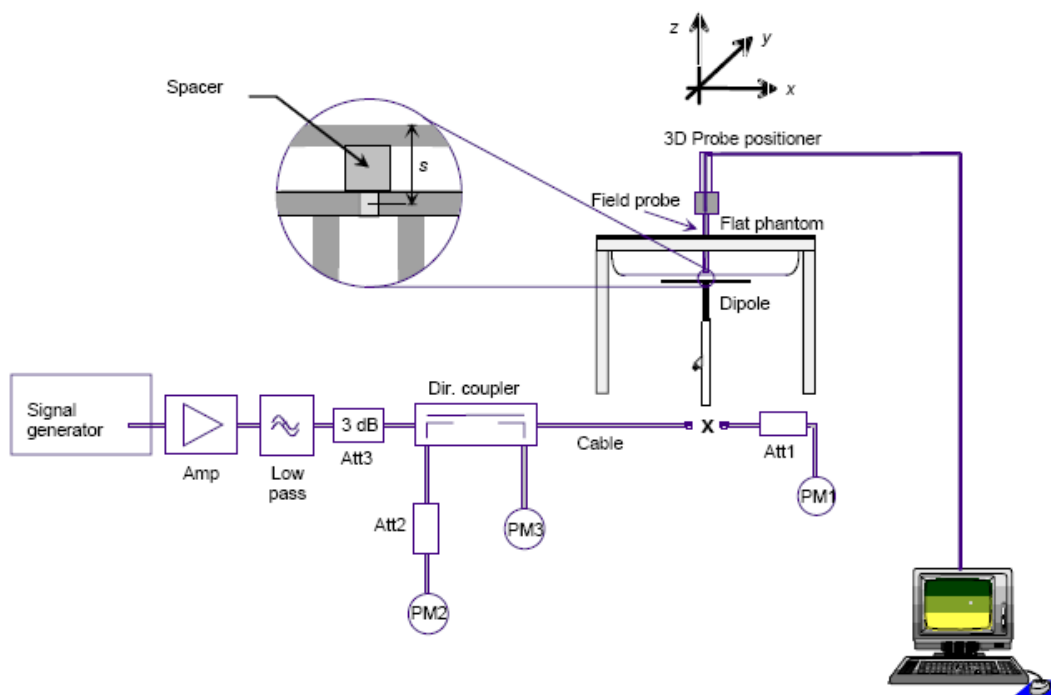

System Accuracy Check Results

Date	Frequency Band (MHz)	Liquid Type	Input Power (mW)	Measured SAR (W/kg)	Normalized to 1W (W/kg)	Target Value (W/Kg)	Delta (%)	Tolerance (%)
2024/08/26	2450	Head	100	1g 5.09	50.9	51.7	-1.547	± 10
2024/08/27	5250	Head	100	1g 7.91	79.1	80.1	-1.248	± 10
2024/08/28	5600	Head	100	1g 8.77	87.7	83.6	4.904	± 10
2024/08/29	5800	Head	100	1g 7.79	77.9	81.4	-4.300	± 10

Note:
All the SAR values are normalized to 1 Watt forward power.

SAR SYSTEM VALIDATION DATA

System Performance 2450 MHz Head

DUT: Dipole 2450 MHz; Type: D2450V2; Serial: 1103

Communication System: UID 0, CW (0); Frequency: 2450 MHz;Duty Cycle: 1:1

Medium parameters used: $f = 2450 \text{ MHz}$; $\sigma = 1.772 \text{ S/m}$; $\epsilon_r = 39.095$; $\rho = 1000 \text{ kg/m}^3$

Phantom section: Flat Section

DASY5 Configuration:

- Probe: EX3DV4 - SN7382; ConvF(7.89, 7.89, 7.89) @ 2450 MHz;
- Sensor-Surface: 1.4mm (Mechanical Surface Detection)
- Electronics: DAE4 Sn1325; Calibrated: 9/27/2023
- Phantom: SAM-Twin V8.0 P1aP2a; Type: QD 000 P41 AA ; Serial: 1962
- Measurement SW: DASY52, Version 52.10 (2);

Configuration/Head 2450MHz Pin=100mW/Area Scan (9x10x1): Measurement grid: $dx=10\text{mm}$, $dy=10\text{mm}$

Maximum value of SAR (measured) = 7.84 W/kg

Configuration/Head 2450MHz Pin=100mW/Zoom Scan (7x7x7)/Cube 0: Measurement grid: $dx=5\text{mm}$, $dy=5\text{mm}$, $dz=5\text{mm}$

Reference Value = 57.56 V/m; Power Drift = -0.14 dB

Peak SAR (extrapolated) = 9.42 W/kg

SAR(1 g) = 5.09 W/kg; SAR(10 g) = 2.51 W/kg

Maximum value of SAR (measured) = 7.96 W/kg

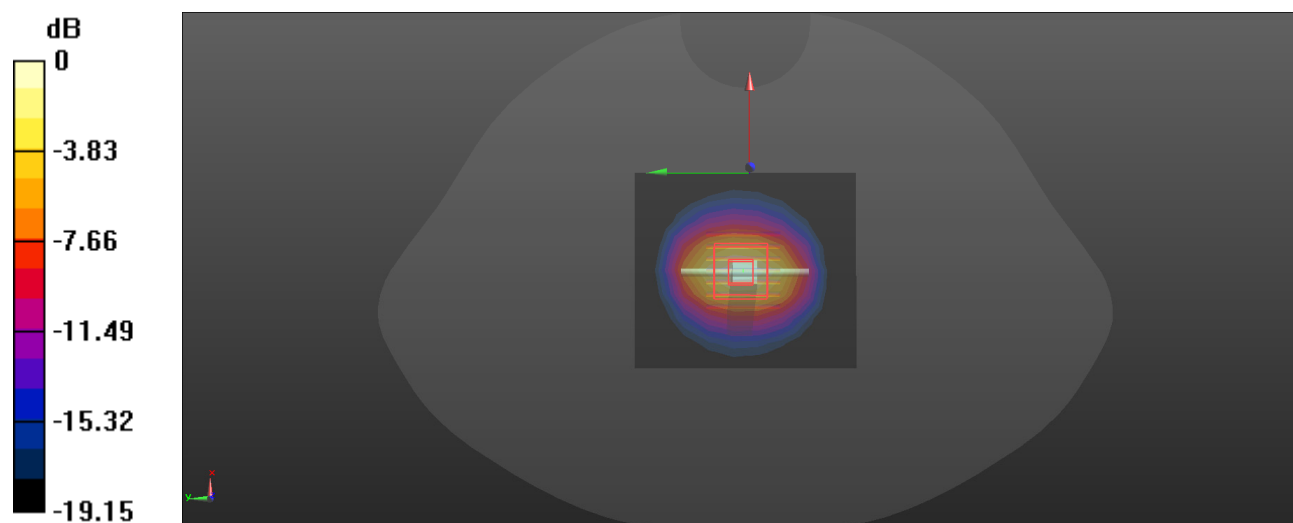

0 dB = 7.96 W/kg = 9.01 dBW/kg

System Performance 5250 MHz Head

DUT: Dipole D5GHz; Type: D5GHzV2; Serial: 1374

Communication System: UID 0, CW (0); Frequency: 5250 MHz;Duty Cycle: 1:1

Medium parameters used: $f = 5250 \text{ MHz}$; $\sigma = 4.715 \text{ S/m}$; $\epsilon_r = 34.59$; $\rho = 1000 \text{ kg/m}^3$

Phantom section: Flat Section

DASY5 Configuration:

- Probe: EX3DV4 - SN7382; ConvF(5.62, 5.62, 5.62) @ 5250 MHz;
- Sensor-Surface: 1.4mm (Mechanical Surface Detection)
- Electronics: DAE4 Sn1325; Calibrated: 9/27/2023
- Phantom: SAM-Twin V8.0 P1aP2a; Type: QD 000 P41 AA ; Serial: 1962
- Measurement SW: DASY52, Version 52.10 (2);

Configuration/Head 5250MHz Pin=100mW/Area Scan (7x9x1): Measurement grid: dx=10mm, dy=10mm

Maximum value of SAR (measured) = 18.3 W/kg

Configuration/Head 5250MHz Pin=100mW/Zoom Scan (8x8x12)/Cube 0: Measurement grid: dx=4mm, dy=4mm, dz=2mm

Reference Value = 46.09 V/m; Power Drift = -0.18 dB

Peak SAR (extrapolated) = 24.1 W/kg

SAR(1 g) = 7.91 W/kg; SAR(10 g) = 2.42 W/kg

Maximum value of SAR (measured) = 16.5 W/kg

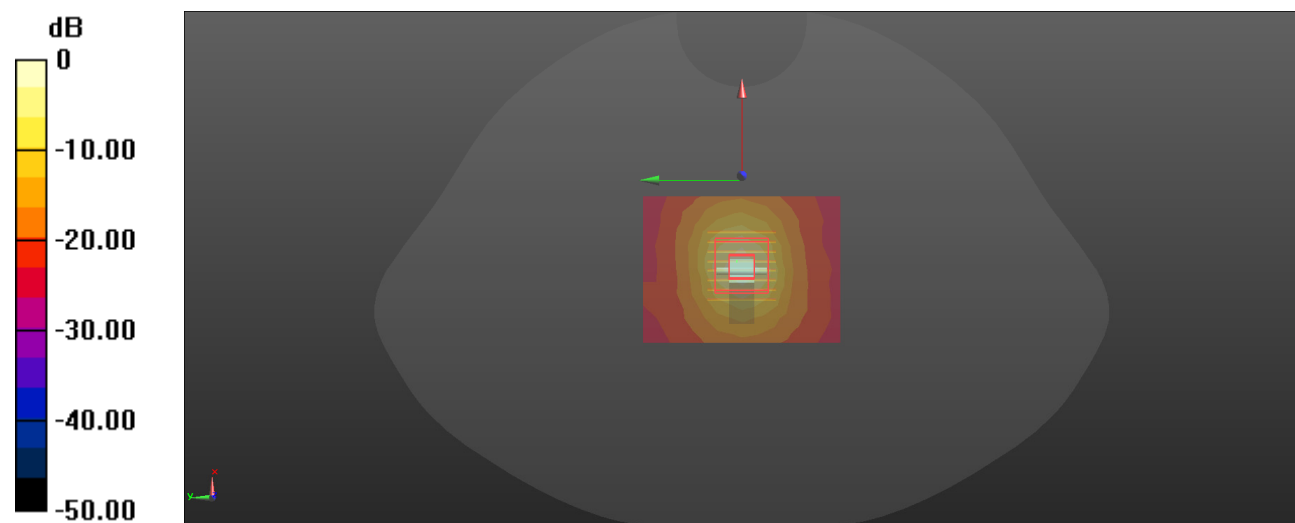

0 dB = 16.5 W/kg = 12.17 dBW/kg

System Performance 5600 MHz Head

DUT: Dipole D5GHz; Type: D5GHzV2; Serial: 1374

Communication System: UID 0, CW (0); Frequency: 5600 MHz;Duty Cycle: 1:1
 Medium parameters used: f = 5600 MHz; $\sigma = 4.959$ S/m; $\epsilon_r = 34.71$; $\rho = 1000$ kg/m³
 Phantom section: Flat Section

DASY5 Configuration:

- Probe: EX3DV4 - SN7382; ConvF(5.1, 5.1, 5.1) @ 5600 MHz;
- Sensor-Surface: 1.4mm (Mechanical Surface Detection)
- Electronics: DAE4 Sn1325; Calibrated: 9/27/2023
- Phantom: SAM-Twin V8.0 P1aP2a; Type: QD 000 P41 AA ; Serial: 1962
- Measurement SW: DASY52, Version 52.10 (2);

Configuration/Head 5600MHz Pin=100mW/Area Scan (7x9x1): Measurement grid: dx=10mm, dy=10mm
 Maximum value of SAR (measured) = 17.8 W/kg

Configuration/Head 5600MHz Pin=100mW/Zoom Scan (8x8x12)/Cube 0: Measurement grid: dx=4mm, dy=4mm, dz=2mm

Reference Value = 43.75 V/m; Power Drift = -0.10 dB

Peak SAR (extrapolated) = 30.3 W/kg

SAR(1 g) = 8.77 W/kg; SAR(10 g) = 2.57 W/kg

Maximum value of SAR (measured) = 19.9 W/kg

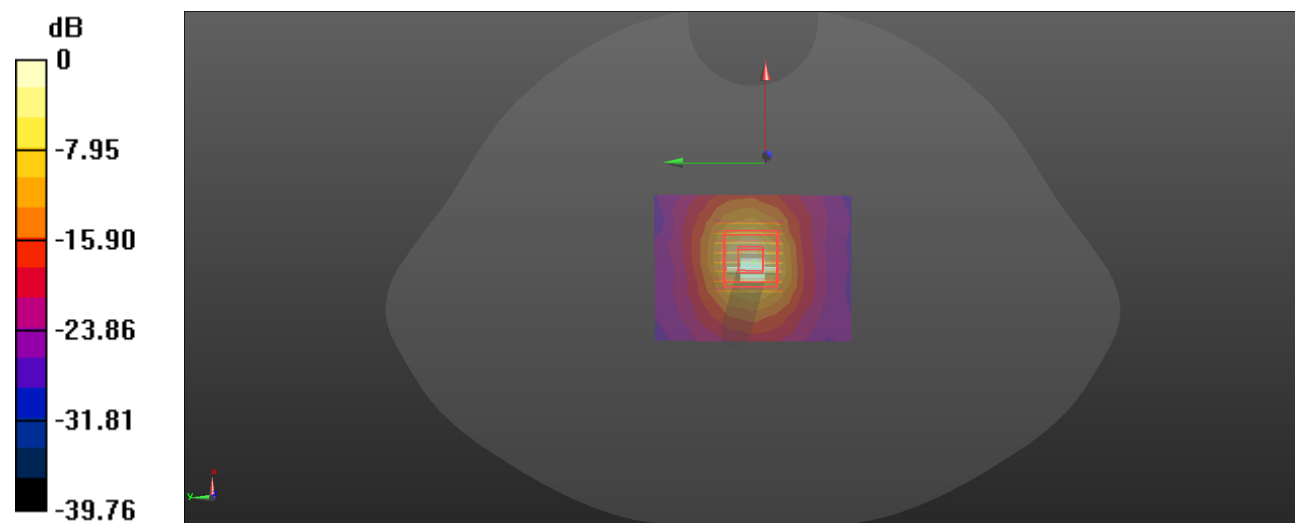

0 dB = 19.9 W/kg = 12.99 dBW/kg

System Performance 5800 MHz Head

DUT: Dipole D5GHz; Type: D5GHzV2; Serial: 1374

Communication System: UID 0, CW (0); Frequency: 5800 MHz;Duty Cycle: 1:1
 Medium parameters used: $f = 5800 \text{ MHz}$; $\sigma = 5.222 \text{ S/m}$; $\epsilon_r = 35.312$; $\rho = 1000 \text{ kg/m}^3$
 Phantom section: Flat Section

DASY5 Configuration:

- Probe: EX3DV4 - SN7382; ConvF(5.08, 5.08, 5.08) @ 5800 MHz;
- Sensor-Surface: 1.4mm (Mechanical Surface Detection)
- Electronics: DAE4 Sn1325; Calibrated: 9/27/2023
- Phantom: SAM-Twin V8.0 P1aP2a; Type: QD 000 P41 AA ; Serial: 1962
- Measurement SW: DASY52, Version 52.10 (2);

Configuration/Head 5800MHz Pin=100mW/Area Scan (7x9x1): Measurement grid: $dx=10\text{mm}$, $dy=10\text{mm}$
 Maximum value of SAR (measured) = 17.7 W/kg

Configuration/Head 5800MHz Pin=100mW/Zoom Scan (8x8x12)/Cube 0: Measurement grid: $dx=4\text{mm}$, $dy=4\text{mm}$, $dz=2\text{mm}$

Reference Value = 41.26 V/m; Power Drift = -0.06 dB

Peak SAR (extrapolated) = 28.1 W/kg

SAR(1 g) = 7.79 W/kg; SAR(10 g) = 2.34 W/kg

Maximum value of SAR (measured) = 18.3 W/kg

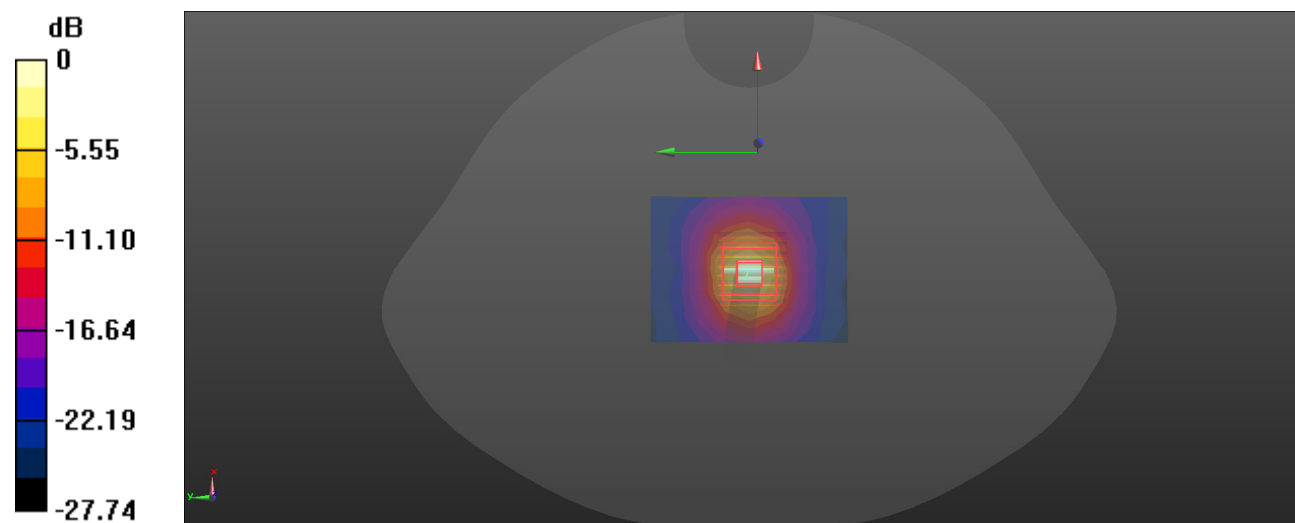

0 dB = 18.3 W/kg = 12.62 dBW/kg

EUT TEST STRATEGY AND METHODOLOGY

Test Positions for Device Operating Next to a Person’s Ear

This category includes most wireless handsets with fixed, retractable or internal antennas located toward the top half of the device, with or without a foldout, sliding or similar keypad cover. The handset should have its earpiece located within the upper ¼ of the device, either along the centerline or off-centered, as perceived by its users. This type of handset should be positioned in a normal operating position with the “test device reference point” located along the “vertical centerline” on the front of the device aligned to the “ear reference point”. The “test device reference point” should be located at the same level as the center of the earpiece region. The “vertical centerline” should bisect the front surface of the handset at its top and bottom edges. A “ear reference point” is located on the outer surface of the head phantom on each ear spacer. It is located 1.5 cm above the center of the ear canal entrance in the “phantom reference plane” defined by the three lines joining the center of each “ear reference point” (left and right) and the tip of the mouth.

A handset should be initially positioned with the earpiece region pressed against the ear spacer of a head phantom. For the SCC-34/SC-2 head phantom, the device should be positioned parallel to the “N-F” line defined along the base of the ear spacer that contains the “ear reference point”. For interim head phantoms, the device should be positioned parallel to the cheek for maximum RF energy coupling. The “test device reference point” is aligned to the “ear reference point” on the head phantom and the “vertical centerline” is aligned to the “phantom reference plane”. This is called the “initial ear position”. While maintaining these three alignments, the body of the handset is gradually adjusted to each of the following positions for evaluating SAR:

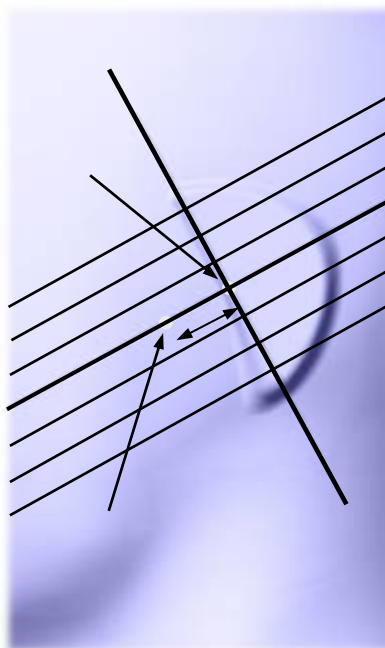
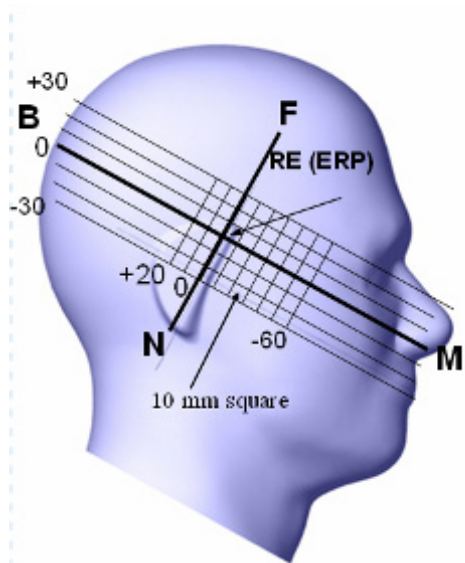

Cheek/Touch Position

The device is brought toward the mouth of the head phantom by pivoting against the “ear reference point” or along the “N-F” line for the SCC-34/SC-2 head phantom.

This test position is established:

When any point on the display, keypad or mouthpiece portions of the handset is in contact with the phantom.

(or) When any portion of a foldout, sliding or similar keypad cover opened to its intended self-adjusting normal use position is in contact with the cheek or mouth of the phantom.

For existing head phantoms – when the handset loses contact with the phantom at the pivoting point, rotation should continue until the device touches the cheek of the phantom or breaks its last contact from the ear spacer.

Cheek /Touch Position

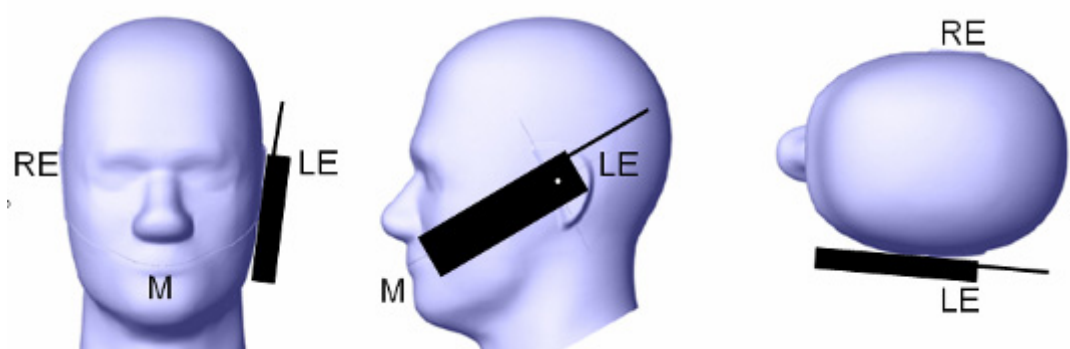

Ear/Tilt Position

With the handset aligned in the “Cheek/Touch Position”:

1) If the earpiece of the handset is not in full contact with the phantom’s ear spacer (in the “Cheek/Touch position”) and the peak SAR location for the “Cheek/Touch” position is located at the ear spacer region or corresponds to the earpiece region of the handset, the device should be returned to the “initial ear position” by rotating it away from the mouth until the earpiece is in full contact with the ear spacer.

2) (otherwise) The handset should be moved (translated) away from the cheek perpendicular to the line passes through both “ear reference points” (note: one of these ear reference points may not physically exist on a split head model) for approximate 2-3 cm. While it is in this position, the device handset is tilted away from the mouth with respect to the “test device reference point” until the inside angle between the vertical centerline on the front surface of the phone and the horizontal line passing through the ear reference point is by 15 80°. After the tilt, it is then moved (translated) back toward the head perpendicular to the line passes through both “ear reference points” until the device touches the phantom or the ear spacer. If the antenna touches the head first, the positioning process should be repeated with a tilt angle less than 15° so that the device and its antenna would touch the phantom simultaneously. This test position may require a device holder or positioner to achieve the translation and tilting with acceptable positioning repeatability.

If a device is also designed to transmit with its keypad cover closed for operating in the head position, such positions should also be considered in the SAR evaluation. The device should be tested on the left and right side of the head phantom in the “Cheek/Touch” and “Ear/Tilt” positions. When applicable, each configuration should be tested with the antenna in its fully extended and fully retracted positions. These test configurations should be tested at the high, middle and low frequency channels of each operating mode; for example, AMPS, CDMA, and TDMA. If the SAR measured at the middle channel for each test configuration (left, right, Cheek/Touch, Tilt/Ear, extended and retracted) is at least 2.0 dB lower than the SAR limit, testing at the high and low channels is optional for such test configuration(s). If the transmission band of the test device is less than 10 MHz, testing at the high and low frequency channels is optional.

Ear /Tilt 15° Position

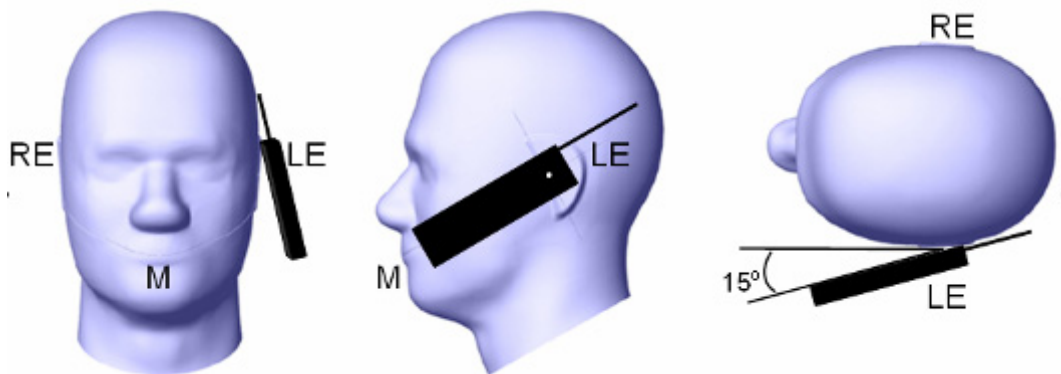

Test positions for body-worn and other configurations

Body-worn operating configurations should be tested with the belt-clips and holsters attached to the device and positioned against a flat phantom in normal use configurations. Devices with a headset output should be tested with a headset connected to the device. When multiple accessories that do not contain metallic components are supplied with the device, the device may be tested with only the accessory that dictates the closest spacing to the body. When multiple accessories that contain metallic components are supplied with the device, the device must be tested with each accessory that contains a unique metallic component. If multiple accessories share an identical metallic component (e.g., the same metallic belt-clip used with different holsters with no other metallic components), only the accessory that dictates the closest spacing to the body must be tested.

Body-worn accessories may not always be supplied or available as options for some devices that are intended to be authorized for body-worn use. A separation distance of 1.5 cm between the back of the device and a flat phantom is recommended for testing body-worn SAR compliance under such circumstances. Other separation distances may be used, but they should not exceed 2.5 cm. In these cases, the device may use body-worn accessories that provide a separation distance greater than that tested for the device provided however that the accessory contains no metallic components.

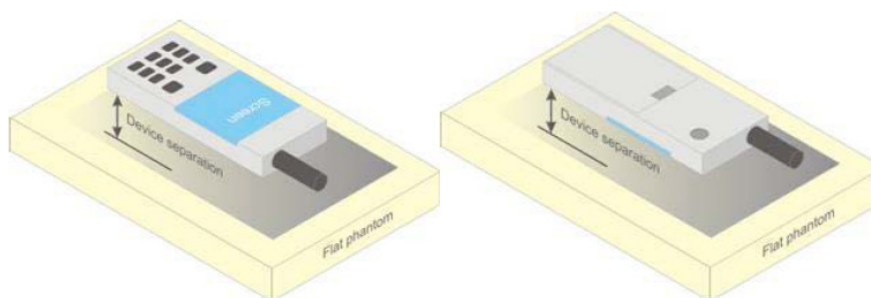

Figure 5 – Test positions for body-worn devices

Test Distance for SAR Evaluation

In this case the EUT (Equipment Under Test) is set 10mm away from the phantom, the test distance is 10mm.

SAR Evaluation Procedure

The evaluation was performed with the following procedure:

Step 1: Measurement of the SAR value at a fixed location above the ear point or central position was used as a reference value for assessing the power drop. The SAR at this point is measured at the start of the test and then again at the end of the testing.

Step 2: The SAR distribution at the exposed side of the head was measured at a distance of 4 mm from the inner surface of the shell. The area covered the entire dimension of the head or radiating structures of the EUT, the horizontal grid spacing was 15 mm x 15 mm, and the SAR distribution was determined by integrated grid of 1.5mm x 1.5mm. Based on these data, the area of the maximum absorption was determined by spline interpolation. The first Area Scan covers the entire dimension of the EUT to ensure that the hotspot was correctly identified.

Step 3: Around this point, a volume of 30 mm x 30 mm x 30 mm was assessed by measuring 7x 7 x 7 points. On the basis of this data set, the spatial peak SAR value was evaluated under the following procedure:

- 1) The data at the surface were extrapolated, since the center of the dipoles is 1.2 mm away from the tip of the probe and the distance between the surface and the lowest measuring point is 1.3 mm. The extrapolation was based on a least square algorithm. A polynomial of the fourth order was calculated through the points in z-axes. This polynomial was then used to evaluate the points between the surface and the probe tip.

- 2) The maximum Measured value was searched with a straightforward algorithm. Around this maximum the SAR values averaged over the spatial volumes (1 g or 10 g) were computed by the 3D-Spline interpolation algorithm. The 3D-Spline is composed of three one dimensional splines with the "Not a knot"-condition (in x, y and z-directions). The volume was integrated with the trapezoidal-algorithm. One thousand points (10 x 10 x 10) were Measured to calculate the averages.

All neighboring volumes were evaluated until no neighboring volume with a higher average value was found.

Step 4: Re-measurement of the SAR value at the same location as in Step 1. If the value changed by more than 5%, the evaluation was repeated.

CONDUCTED OUTPUT POWER MEASUREMENT

Test Procedure

The RF output of the transmitter was connected to the input of the Spectrum Analyzer.

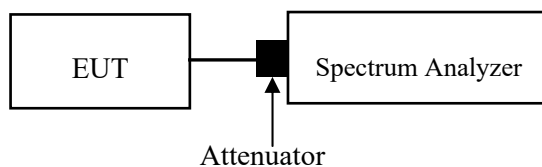

WLAN & Bluetooth & BLE

Maximum Target Output Power

Max Target Power(dBm)			
Mode/Band	Channel		
	Low	Middle	High
WLAN 2.4G(802.11b)	16.6	17.4	16.4
WLAN 2.4G(802.11g)	13.1	16.8	13.0
WLAN 2.4G(802.11n-HT20)	12.9	14.9	12.1
WLAN 2.4G(802.11n-HT40)	9.7	13.9	9.7
WLAN 2.4G(802.11ax-VHT20)	11.5	16.9	11.4
WLAN 2.4G(802.11ax-VHT40)	10.9	12.7	10.8
WLAN 5.2G(802.11a)	19.5	20.2	20.2
WLAN 5.2G(802.11n-HT20)	20.8	20.1	19.8
WLAN 5.2G(802.11n-HT40)	16.7	/	19.7
WLAN 5.2G(802.11ac-VHT20)	20.8	20.1	19.8
WLAN 5.2G(802.11ac-VHT40)	16.7	/	19.7
WLAN 5.2G(802.11ac-VHT80)	/	15.4	/
WLAN 5.2G(802.11ax-VHT20)	20.5	20.1	20.1
WLAN 5.2G(802.11ax-VHT40)	17.3	/	20.8
WLAN 5.2G(802.11ax-VHT80)	/	15.8	/
WLAN 5.3G(802.11a)	19.2	20.4	19.2
WLAN 5.3G(802.11n-HT20)	20.0	20.4	20.2
WLAN 5.3G(802.11n-HT40)	19.2	/	15.6
WLAN 5.3G(802.11ac-VHT20)	20.0	20.4	20.2
WLAN 5.3G(802.11ac-VHT40)	19.2	/	15.6
WLAN 5.3G(802.11ac-VHT80)	/	14.2	/
WLAN 5.3G(802.11ax-VHT20)	20.1	20.5	19.4
WLAN 5.3G(802.11ax-VHT40)	20.3	/	16.2
WLAN 5.3G(802.11ax-VHT80)	/	15.0	/

Max Target Power(dBm)			
Mode/Band	Channel		
	Low	Middle	High
WLAN 5.6G(802.11a)	17.4	20.3	18.7
WLAN 5.6G(802.11n-HT20)	17.2	19.4	18.6
WLAN 5.6G(802.11n-HT40)	14.5	18.8	19.0
WLAN 5.6G(802.11ac-VHT20)	17.2	19.4	18.6
WLAN 5.6G(802.11ac-VHT40)	14.5	18.8	19.0
WLAN 5.6G(802.11ac-VHT80)	13.8	18.1	19.1
WLAN 5.6G(802.11ac-VHT160)	/	10.7	/
WLAN 5.6G(802.11ax-VHT20)	17.5	19.4	18.7
WLAN 5.6G(802.11ax-VHT40)	14.5	19.8	19.1
WLAN 5.6G(802.11ax-VHT80)	14.5	17.4	19.4
WLAN 5.6G(802.11ax-VHT160)	/	11.0	/
WLAN 5.8G(802.11a)	19.3	19.5	16.6
WLAN 5.8G(802.11n-HT20)	18.3	18.5	17.6
WLAN 5.8G(802.11n-HT40)	18.3	/	18.4
WLAN 5.8G(802.11ac-HT20)	18.3	18.5	17.6
WLAN 5.8G(802.11ac-HT40)	18.3	/	18.4
WLAN 5.8G(802.11ac-VHT80)	/	19.1	/
WLAN 5.8G(802.11ax-HT20)	19.6	18.6	17.9
WLAN 5.8G(802.11ax-HT40)	19.7	/	18.5
WLAN 5.8G(802.11ax-VHT80)	/	19.6	/
WLAN 5.9G(802.11a)	16.4	17.4	16.4
WLAN 5.9G(802.11n-HT20)	17.1	17.1	17.1
WLAN 5.9G(802.11n-HT40)	16.0	/	16.0
WLAN 5.9G(802.11ac-HT20)	17.1	17.1	17.1
WLAN 5.9G(802.11ac-HT40)	16.0	/	16.0
WLAN 5.9G(802.11ac-VHT80)	/	14.0	/
WLAN 5.9G(802.11ac-VHT160)	/	20.1	/
WLAN 5.9G(802.11ax-HT20)	16.1	17.0	17.0
WLAN 5.9G(802.11ax-HT40)	15.4	/	15.4
WLAN 5.9G(802.11ax-VHT80)	/	13.8	/
WLAN 5.9G(802.11ax-VHT160)	/	19.9	/
Bluetooth BDR(GFSK)	8.0	8.0	8.0
Bluetooth BDR($\pi/4$ -DQPSK)	8.0	8.0	8.0
Bluetooth EDR(8DPSK)	8.0	8.0	8.0
BLE 1M	6.0	6.0	6.0
BLE 2M	6.0	6.0	6.0

Wi-Fi (2.4G Band)

Band	Channel Frequency (MHz)	RF Average Output Power	
		(dBm)	(mW)
802.11b	2412	16.30	42.658
	2437	17.10	51.286
	2462	16.10	40.738
802.11g	2412	12.83	19.187
	2437	16.45	44.157
	2462	12.77	18.923
802.11n-HT20	2412	12.65	18.408
	2437	14.62	28.973
	2462	11.80	15.136
802.11n-HT40	2422	9.41	8.730
	2437	13.68	23.335
	2452	9.32	8.551
802.11ax-VHT20	2412	11.23	13.274
	2437	15.68	36.983
	2462	11.12	12.942
802.11ax-VHT40	2422	10.65	11.614
	2437	12.40	17.378
	2452	10.53	11.298

Duty Cycle:

Mode	Duty Cycle(%)
802.11b	95.88
802.11g	97.89
802.11 n20	97.74
802.11 n40	53.78
802.11 ax20	83.47
802.11 ax40	45.00

Note: Duty cycle was from Radio report

Wi-Fi (5.2G Band)

Band	Channel Frequency (MHz)	RF Average Output Power	
		(dBm)	(mW)
802.11a	5180	19.19	82.985
	5200	19.92	98.175
	5240	19.93	98.401
802.11n-HT20	5180	20.28	104.954
	5200	19.83	96.161
	5240	19.52	89.536
802.11n-HT40	5190	16.40	43.652
	5230	19.40	87.096
802.11ac-VHT20	5180	20.36	104.713
	5200	19.74	94.189
	5240	19.53	89.743
802.11ac-VHT40	5190	16.28	42.462
	5230	19.43	87.700
802.11ac-VHT80	5210	14.95	31.261
802.11ac-VHT160	5250_UNII-1	9.61	9.141
802.11ax-VHT20	5180	20.17	103.992
	5200	19.95	98.855
	5240	19.87	97.051
802.11ax-VHT40	5190	16.99	50.003
	5230	20.31	116.681
802.11ax-VHT80	5210	15.50	35.481
802.11ax-VHT160	5250_UNII-1	10.01	10.023

Duty Cycle:

Mode	Duty Cycle(%)
802.11a	97.20
802.11 n20	97.04
802.11 n40	55.56
802.11 ac20	97.04
802.11 ac40	55.56
802.11 ac80	27.12
802.11 ax20	85.00
802.11 ax40	45.30
802.11 ax80	24.17

Note: Duty cycle was from Radio report

Wi-Fi (5.3G Band)

Band	Channel Frequency (MHz)	RF Average Output Power	
		(dBm)	(mW)
802.11a	5260	18.82	76.208
	5280	20.13	103.039
	5320	18.90	77.625
802.11n-HT20	5260	19.84	96.383
	5280	20.12	102.802
	5320	19.96	99.083
802.11n-HT40	5270	18.93	78.163
	5310	15.31	33.963
802.11ac-VHT20	5260	19.74	94.189
	5280	20.13	103.039
	5320	19.96	99.083
802.11ac-VHT40	5270	18.93	78.163
	5310	15.24	33.420
802.11ac-VHT80	5290	13.93	24.717
802.11ax-VHT20	5260	19.78	95.060
	5280	20.17	103.992
	5320	19.11	81.470
802.11ax-VHT40	5270	20.06	101.391
	5310	15.79	37.931
802.11ax-VHT80	5290	14.59	28.774

Duty Cycle:

Mode	Duty Cycle(%)
802.11a	97.89
802.11 n20	97.04
802.11 n40	55.08
802.11 ac20	97.04
802.11 ac40	55.08
802.11 ac80	27.97
802.11 ax20	86.44
802.11 ax40	45.76
802.11 ax80	23.93

Note: Duty cycle was from Radio report

Wi-Fi (5.6G Band)

Band	Channel Frequency (MHz)	RF Average Output Power	
		(dBm)	(mW)
802.11a	5500	17.02	50.350
	5580	19.89	97.499
	5700	15.61	36.392
	5720_UNII-2C	18.41	69.343
802.11n-HT20	5500	16.89	48.865
	5580	19.08	80.910
	5700	15.35	34.277
	5720_UNII-2C	18.21	66.222
802.11n-HT40	5510	14.13	25.882
	5550	18.50	70.795
	5670	18.30	67.608
	5710_UNII-2C	18.82	76.208
802.11ac-VHT20	5500	16.93	49.317
	5580	19.21	83.368
	5700	15.38	34.514
	5720_UNII-2C	18.24	66.681
802.11ac-VHT40	5510	14.14	25.942
	5550	18.37	68.707
	5670	18.25	66.834
	5720_UNII-2C	18.77	75.336
802.11ac-VHT80	5530	13.47	22.233
	5610	17.78	59.979
	5690_UNII-2C	18.89	77.446
802.11ac-VHT160	5570	10.44	11.066

Band	Channel Frequency (MHz)	RF Average Output Power	
		(dBm)	(mW)
802.11ax-VHT20	5500	17.23	52.845
	5580	19.12	81.658
	5700	14.64	29.107
	5720_UNII-2C	18.41	69.343
802.11ax-VHT40	5510	14.15	26.002
	5550	19.57	90.573
	5670	17.44	55.463
	5710_UNII-2C	18.84	76.560
802.11ax-VHT80	5530	14.04	25.351
	5610	17.08	51.050
	5690_UNII-2C	19.11	81.470
802.11ax-VHT160	5570	10.67	11.668

Duty Cycle:

Mode	Duty Cycle(%)
802.11a	97.89
802.11 n20	97.04
802.11 n40	55.08
802.11 ac20	97.04
802.11 ac40	55.08
802.11 ac80	27.97
802.11 ac160	16.10
802.11 ax20	86.32
802.11 ax40	44.54
802.11 ax80	23.93
802.11 ax160	14.17

Note: Duty cycle was from Radio report

Wi-Fi (5.8G Band)

Band	Channel Frequency (MHz)	RF Average Output Power	
		(dBm)	(mW)
802.11a	5745	17.97	62.661
	5785	18.23	66.527
	5825	16.36	43.251
802.11n-HT20	5745	17.94	62.230
	5785	18.18	65.766
	5825	17.29	53.580
802.11n-HT40	5755	17.95	62.373
	5795	18.05	63.826
802.11ac-VHT20	5745	18.03	63.533
	5785	18.28	67.298
	5825	17.43	55.335
802.11ac-VHT40	5755	18.03	63.533
	5795	18.11	64.714
802.11ac-VHT80	5775	18.77	75.336
802.11ax-VHT20	5745	19.21	83.368
	5785	18.36	68.549
	5825	17.65	58.210
802.11ax-VHT40	5755	19.39	86.896
	5795	18.24	66.681
802.11ax-VHT80	5775	19.33	85.704

Duty Cycle:

Mode	Duty Cycle(%)
802.11a	97.89
802.11 n20	97.76
802.11 n40	55.56
802.11 ac20	97.76
802.11 ac40	55.56
802.11 ac80	27.97
802.11 ax20	85.71
802.11 ax40	94.33
802.11 ax80	23.58

Note: Duty cycle was from Radio report

Wi-Fi (5.9G Band, 5725-5850MHz & 5850-5895MHz Bands span channels)

Band	Channel Frequency (MHz)	RF Average Output Power	
		(dBm)	(mW)
802.11a	5845	16.10	40.738
	5865	17.02	50.350
	5885	16.09	40.644
802.11n-HT20	5845	16.80	47.863
	5865	16.87	48.641
	5885	16.95	49.545
802.11n-HT40	5835	15.67	36.898
	5875	15.88	38.726
802.11ac-VHT20	5845	16.90	48.978
	5865	16.83	48.195
	5885	16.88	48.753
802.11ac-VHT40	5835	15.68	36.983
	5875	15.87	38.637
802.11ac-VHT80	5855	13.71	23.496
802.11ac-VHT160	5815	19.85	96.605
802.11ax-VHT20	5845	15.79	37.931
	5865	16.72	46.989
	5885	16.73	47.098
802.11ax-VHT40	5835	15.13	32.584
	5875	15.09	32.285
802.11ax-VHT80	5855	13.46	22.182
802.11ax-VHT160	5815	19.51	89.331

Duty Cycle:

Mode	Duty Cycle(%)
802.11a	97.20
802.11 n20	97.04
802.11 n40	55.56
802.11 ac20	97.04
802.11 ac40	55.56
802.11 ac80	27.12
802.11 ac160	96.67
802.11 ax20	86.32
802.11 ax40	92.98
802.11 ax80	24.17
802.11 ax160	96.97

Note: Duty cycle was from Radio report

Bluetooth:

Mode	Channel frequency (MHz)	Duty cycle (%)	RF Output Power (dBm)	
BDR Mode (GFSK)	2402	/	7.73	
	2441		7.43	
	2480		7.67	
EDR Mode ($\pi/4$ -DQPSK)	2402		7.58	
	2441		7.48	
	2480		7.48	
EDR Mode (8DPSK)	2402		7.69	
	2441		7.52	
	2480		7.69	
BLE 1M	2402		85.20	5.84
	2440			5.57
	2480			5.72
BLE 2M	2402	56.91	5.62	
	2440		5.40	
	2480		5.54	

Note: Duty cycle was from Radio report

STANDALONE SAR TEST EXCLUSION CONSIDERATIONS

Antennas Location:

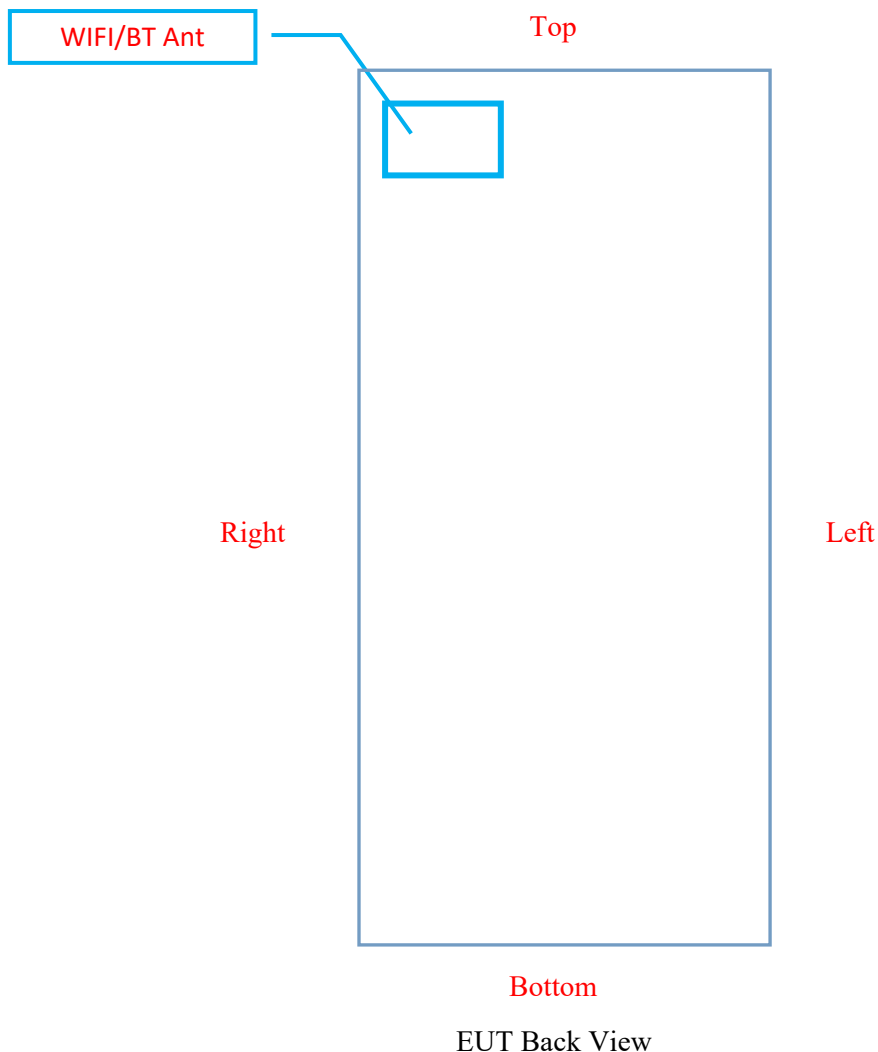

Antenna	Description
WIFI/BT	WIFI: ■ IEEE 802.11 a/b/g/n/ac/ax compliant ■ Support 20/40MHz bandwidth in 2.4GHz and 20/40/80/160MHz in 5GHz ■ Support uplink MU-OFDMA TX and downlink MU-OFDMA RX BT: ■ Bluetooth v5.3 with BLE (BT low energy) ■ Supports BT/BLE dual mode ■ Supports BT/Wi-Fi coexistence

Note: The above statistics only include antennas with transmitting

Standalone SAR test exclusion considerations

Mode	Frequency (MHz)	Output Power (dBm)	Output Power (mW)	Distance (mm)	Calculated value	Threshold (1-g)	SAR Test Exclusion
WLAN 2.4G	2462	17.4	54.95	< 5	17.2	3	NO
WLAN 5.2G	5240	20.8	120.23	< 5	55.0	3	NO
WLAN 5.3G	5320	20.5	112.20	< 5	51.8	3	NO
WLAN 5.6G	5720	20.3	107.15	< 5	51.3	3	NO
WLAN 5.8G	5825	19.7	93.33	< 5	45.0	3	NO
WLAN 5.9G	5815	20.1	102.33	< 5	49.4	3	NO
Bluetooth	2480	8.0	6.31	< 5	2.0	3	YES

NOTE:

The 1-g and 10-g SAR test exclusion thresholds for 100 MHz to 6 GHz at test separation distances ≤ 50 mm are determined by:

$$[(\text{max. power of channel, including tune-up tolerance, mW}) / (\text{min. test separation distance, mm})] \cdot [\sqrt{f(\text{GHz})}] \leq 3.0 \text{ for 1-g SAR and } \leq 7.5 \text{ for 10-g extremity SAR, where}$$

[$\sqrt{f(\text{GHz})}$] ≤ 3.0 for 1-g SAR and ≤ 7.5 for 10-g extremity SAR, where

1. f(GHz) is the RF channel transmit frequency in GHz.
2. Power and distance are rounded to the nearest mW and mm before calculation.
3. The result is rounded to one decimal place for comparison.
4. When the minimum test separation distance is < 5 mm, a distance of 5 mm is applied to determine SAR test Exclusion.

Antenna Distance To Edge (TRX)

Antenna Distance To Edge(mm)						
Antenna	Back	Front	Left	Right	Top	Bottom
WIFI/BT	10	< 5	51	< 5	< 5	143

SAR test exclusion for the EUT edge considerations Result

Expand Use Mode:

Mode	Back	Front	Left	Right	Top	Bottom
WLAN	Required	Required	Exclusion	Required	Required	Exclusion

Note:

Required : The distance to Edge is less than 25mm, testing is required.

Exclusion: The distance to Edge is more than 25 mm, testing is not required.

SAR MEASUREMENT RESULTS

This page summarizes the results of the performed dosimetry evaluation.

Test Results:

Environmental Conditions:

Temperature:	22 ~ 23.4°C	22.3 ~ 24°C	21.9 ~ 23.7°C	21.9 ~ 23.7°C
Relative Humidity:	54 ~ 58%	54 ~ 63%	51 ~ 69%	51 ~ 64%
ATM Pressure:	101.3 kPa	101.3 kPa	101.3 kPa	101.3 kPa
Test Date:	2024/08/26	2024/08/27	2024/08/28	2024/08/29

* Testing was performed by Bob Lu, Calvin Li and Sid Luo.

WLAN 2.4G:

EUT Position	Frequency (MHz)	Test Mode	Max. Meas. Power (dBm)	Max. Rated Power (dBm)	Scaled Factor	1g SAR (W/Kg)				
						Duty cycle Factor	Meas.	Scaled SAR	Limit	Plot
Head Left Cheek	2412	802.11b	16.30	16.6	1.072	1.04	1.140	1.27	1.6	1
	2437	802.11b	17.10	17.4	1.072	1.04	1.170	1.31	1.6	2
	2462	802.11b	16.10	16.4	1.072	1.04	1.190	1.33	1.6	3
Head Left Tilt	2412	802.11b	/	/	/	/	/	/	/	/
	2437	802.11b	17.10	17.4	1.072	1.04	0.664	0.74	1.6	4
	2462	802.11b	/	/	/	/	/	/	/	/
Head Right Cheek	2412	802.11b	/	/	/	/	/	/	/	/
	2437	802.11b	17.10	17.4	1.072	1.04	0.786	0.88	1.6	5
	2462	802.11b	/	/	/	/	/	/	/	/
Head Right Tilt	2412	802.11b	/	/	/	/	/	/	/	/
	2437	802.11b	17.10	17.4	1.072	1.04	0.583	0.65	1.6	6
	2462	802.11b	/	/	/	/	/	/	/	/
Body Front (10mm)	2412	802.11b	/	/	/	/	/	/	/	/
	2437	802.11b	17.10	17.4	1.072	1.04	0.280	0.31	1.6	7
	2462	802.11b	/	/	/	/	/	/	/	/
Body Back (10mm)	2412	802.11b	16.30	16.6	1.072	1.04	0.304	0.34	1.6	8
	2437	802.11b	17.10	17.4	1.072	1.04	0.385	0.43	1.6	9
	2462	802.11b	16.10	16.4	1.072	1.04	0.370	0.41	1.6	10
Body Right (10mm)	2412	802.11b	/	/	/	/	/	/	/	/
	2437	802.11b	17.10	17.4	1.072	1.04	0.322	0.36	1.6	11
	2462	802.11b	/	/	/	/	/	/	/	/
Body Top (10mm)	2412	802.11b	/	/	/	/	/	/	/	/
	2437	802.11b	17.10	17.4	1.072	1.04	0.241	0.27	1.6	12
	2462	802.11b	/	/	/	/	/	/	/	/

Note:

1. When the 1-g SAR is $\leq 0.8W/kg$, testing for other channels are optional.
2. When SAR or MPE is not measured at the maximum power level allowed for production units, the results must be scaled to the maximum tune-up tolerance limit according to the power applied to the individual channels tested to determine compliance.
3. For 802.11b mode power is the largest among 802.11b/g/n20/n40/ax20/ax40, 802.11 b mode as initial test configuration is selected to test.

WLAN 5.2G:

EUT Position	Frequency (MHz)	Test Mode	Max. Meas. Power (dBm)	Max. Rated Power (dBm)	1g SAR (W/Kg)					
					Scaled Factor	Duty cycle Factor	Meas.	Scaled SAR	Limit	Plot
Head Left Cheek	5180	802.11ac20	20.36	20.8	1.107	1.031	0.946	1.08	1.6	13
	5200	802.11ac20	19.74	20.1	1.086	1.031	0.924	1.03	1.6	14
	5240	802.11ac20	19.53	19.8	1.064	1.031	0.981	1.08	1.6	15
Head Left Tilt	5180	802.11ac20	20.36	20.8	1.107	1.031	0.907	1.03	1.6	16
	5200	802.11ac20	19.74	20.1	1.086	1.031	0.794	0.89	1.6	17
	5240	802.11ac20	19.53	19.8	1.064	1.031	0.835	0.92	1.6	18
Head Right Cheek	5180	802.11ac20	/	/	/	/	/	/	/	/
	5200	802.11ac20	19.74	20.1	1.086	1.031	0.611	0.68	1.6	19
	5240	802.11ac20	/	/	/	/	/	/	/	/
Head Right Tilt	5180	802.11ac20	/	/	/	/	/	/	/	/
	5200	802.11ac20	19.74	20.1	1.086	1.031	0.473	0.53	1.6	20
	5240	802.11ac20	/	/	/	/	/	/	/	/
Body Front (10mm)	5180	802.11ac20	/	/	/	/	/	/	/	/
	5200	802.11ac20	19.74	20.1	1.086	1.031	0.338	0.38	1.6	21
	5240	802.11ac20	/	/	/	/	/	/	/	/
Body Back (10mm)	5180	802.11ac20	20.36	20.8	1.107	1.031	0.513	0.59	1.6	22
	5200	802.11ac20	19.74	20.1	1.086	1.031	0.590	0.66	1.6	23
	5240	802.11ac20	19.53	19.8	1.064	1.031	0.601	0.66	1.6	24
Body Right (10mm)	5180	802.11ac20	/	/	/	/	/	/	/	/
	5200	802.11ac20	19.74	20.1	1.086	1.031	0.256	0.29	1.6	25
	5240	802.11ac20	/	/	/	/	/	/	/	/
Body Top (10mm)	5180	802.11ac20	/	/	/	/	/	/	/	/
	5200	802.11ac20	19.74	20.1	1.086	1.031	0.404	0.45	1.6	26
	5240	802.11ac20	/	/	/	/	/	/	/	/

Note:

1. When the 1-g SAR is $\leq 0.8W/kg$, testing for other channels are optional.
2. When SAR or MPE is not measured at the maximum power level allowed for production units, the results must be scaled to the maximum tune-up tolerance limit according to the power applied to the individual channels tested to determine compliance.
3. For 802.11ac20 mode power is the largest among 802.11a/n20/n40/ac20/ac40/ac80/ac160/ax20/ax40/ax80/ax160, 802.11 ac20 mode as initial test configuration is selected to test.

WLAN 5.3G:

EUT Position	Frequency (MHz)	Test Mode	Max. Meas. Power (dBm)	Max. Rated Power (dBm)	Scaled Factor	1g SAR (W/Kg)				
						Duty cycle Factor	Meas.	Scaled SAR	Limit	Plot
Head Left Cheek	5260	802.11ax20	19.78	20.1	1.076	1.157	0.976	1.22	1.6	27
	5280	802.11ax20	20.17	20.5	1.079	1.157	1.110	1.39	1.6	28
	5320	802.11ax20	19.11	19.4	1.069	1.157	1.200	1.48	1.6	29
Head Left Tilt	5260	802.11ax20	19.78	20.1	1.076	1.157	0.870	1.08	1.6	30
	5280	802.11ax20	20.17	20.5	1.079	1.157	0.856	1.07	1.6	31
	5320	802.11ax20	19.11	19.4	1.069	1.157	0.959	1.19	1.6	32
Head Right Cheek	5260	802.11ax20	/	/	/	/	/	/	/	/
	5280	802.11ax20	20.17	20.5	1.079	1.157	0.689	0.86	1.6	33
	5320	802.11ax20	/	/	/	/	/	/	/	/
Head Right Tilt	5260	802.11ax20	/	/	/	/	/	/	/	/
	5280	802.11ax20	20.17	20.5	1.079	1.157	0.662	0.83	1.6	34
	5320	802.11ax20	/	/	/	/	/	/	/	/
Body Front (10mm)	5260	802.11ax20	/	/	/	/	/	/	/	/
	5280	802.11ax20	20.17	20.5	1.079	1.157	0.427	0.53	1.6	35
	5320	802.11ax20	/	/	/	/	/	/	/	/
Body Back (10mm)	5260	802.11ax20	19.78	20.1	1.076	1.157	0.682	0.85	1.6	36
	5280	802.11ax20	20.17	20.5	1.079	1.157	0.698	0.87	1.6	37
	5320	802.11ax20	19.11	19.4	1.069	1.157	0.746	0.92	1.6	38
Body Right (10mm)	5260	802.11ax20	/	/	/	/	/	/	/	/
	5280	802.11ax20	20.17	20.5	1.079	1.157	0.300	0.37	1.6	39
	5320	802.11ax20	/	/	/	/	/	/	/	/
Body Top (10mm)	5260	802.11ax20	/	/	/	/	/	/	/	/
	5280	802.11ax20	20.17	20.5	1.079	1.157	0.491	0.61	1.6	40
	5320	802.11ax20	/	/	/	/	/	/	/	/

Note:

1. When the 1-g SAR is $\leq 0.8W/kg$, testing for other channels are optional.
2. When SAR or MPE is not measured at the maximum power level allowed for production units, the results must be scaled to the maximum tune-up tolerance limit according to the power applied to the individual channels tested to determine compliance.
3. For 802.11ax20 mode power is the largest among 802.11a/n20/n40/ac20/ac40/ac80/ax20/ax40/ax80, 802.11ax20 mode as initial test configuration is selected to test.

WLAN 5.6G:

EUT Position	Frequency (MHz)	Test Mode	Max. Meas. Power (dBm)	Max. Rated Power (dBm)	Scaled Factor	1g SAR (W/Kg)				
						Duty cycle Factor	Meas.	Scaled SAR	Limit	Plot
Head Left Cheek	5500	802.11a	17.02	17.4	1.091	1.022	1.120	1.25	1.6	41
	5580	802.11a	19.89	20.3	1.099	1.022	1.330	1.49	1.6	42
	5720	802.11a	18.41	18.7	1.069	1.022	1.110	1.21	1.6	43
Head Left Tilt	5500	802.11a	17.02	17.4	1.091	1.022	1.130	1.26	1.6	44
	5580	802.11a	19.89	20.3	1.099	1.022	0.830	0.93	1.6	45
	5720	802.11a	18.41	18.7	1.069	1.022	0.597	0.65	1.6	46
Head Right Cheek	5500	802.11a	17.02	17.4	1.091	1.022	1.070	1.19	1.6	47
	5580	802.11a	19.89	20.3	1.099	1.022	0.945	1.06	1.6	48
	5720	802.11a	18.41	18.7	1.069	1.022	0.683	0.75	1.6	49
Head Right Tilt	5500	802.11a	/	/	/	/	/	/	/	/
	5580	802.11a	19.89	20.3	1.099	1.022	0.627	0.70	1.6	50
	5720	802.11a	/	/	/	/	/	/	/	/
Body Front (10mm)	5500	802.11a	/	/	/	/	/	/	/	/
	5580	802.11a	19.89	20.3	1.099	1.022	0.439	0.49	1.6	51
	5720	802.11a	/	/	/	/	/	/	/	/
Body Back (10mm)	5500	802.11a	17.02	17.4	1.091	1.022	1.080	1.20	1.6	52
	5580	802.11a	19.89	20.3	1.099	1.022	0.809	0.91	1.6	53
	5720	802.11a	18.41	18.7	1.069	1.022	0.627	0.68	1.6	54
Body Right (10mm)	5500	802.11a	/	/	/	/	/	/	/	/
	5580	802.11a	19.89	20.3	1.099	1.022	0.505	0.57	1.6	55
	5720	802.11a	/	/	/	/	/	/	/	/
Body Top (10mm)	5500	802.11a	/	/	/	/	/	/	/	/
	5580	802.11a	19.89	20.3	1.099	1.022	0.637	0.72	1.6	56
	5720	802.11a	/	/	/	/	/	/	/	/

Note:

1. When the 1-g SAR is $\leq 0.8W/kg$, testing for other channels are optional.
2. When SAR or MPE is not measured at the maximum power level allowed for production units, the results must be scaled to the maximum tune-up tolerance limit according to the power applied to the individual channels tested to determine compliance.
3. For 802.11a mode power is the largest among 802.11a/n20/n40/ac20/ac40/ac80/ac160/ax20/ax40/ax80/ax160, 802.11 a mode as initial test configuration is selected to test.

WLAN 5.8G:

EUT Position	Frequency (MHz)	Test Mode	Max. Meas. Power (dBm)	Max. Rated Power (dBm)	Scaled Factor	1g SAR (W/Kg)				
						Duty cycle Factor	Meas.	Scaled SAR	Limit	Plot
Head Left Cheek	5755	802.11 ax40	19.39	19.7	1.074	1.060	1.370	1.56	1.6	57
	/	/	/	/	/	/	/	/	/	/
	5795	802.11 ax40	18.24	18.5	1.062	1.060	1.280	1.44	1.6	58
Head Left Tilt	5755	802.11 ax40	19.39	19.7	1.074	1.060	0.714	0.81	1.6	59
	/	/	/	/	/	/	/	/	/	/
	5795	802.11 ax40	/	/	/	/	/	/	/	/
Head Right Cheek	5755	802.11 ax40	19.39	19.7	1.074	1.060	0.571	0.65	1.6	60
	/	/	/	/	/	/	/	/	/	/
	5795	802.11 ax40	/	/	/	/	/	/	/	/
Head Right Tilt	5755	802.11 ax40	19.39	19.7	1.074	1.060	0.497	0.57	1.6	61
	/	/	/	/	/	/	/	/	/	/
	5795	802.11 ax40	/	/	/	/	/	/	/	/
Body Front (10mm)	5755	802.11 ax40	19.39	19.7	1.074	1.060	0.331	0.38	1.6	62
	/	/	/	/	/	/	/	/	/	/
	5795	802.11 ax40	/	/	/	/	/	/	/	/
Body Back (10mm)	5755	802.11 ax40	19.39	19.7	1.074	1.060	0.719	0.82	1.6	63
	/	/	/	/	/	/	/	/	/	/
	5795	802.11 ax40	18.24	18.5	1.062	1.060	0.619	0.70	1.6	64
Body Right (10mm)	5755	802.11 ax40	19.39	19.7	1.074	1.060	0.610	0.69	1.6	65
	/	/	/	/	/	/	/	/	/	/
	5795	802.11 ax40	/	/	/	/	/	/	/	/
Body Top (10mm)	5755	802.11 ax40	19.39	19.7	1.074	1.060	0.512	0.58	1.6	66
	/	/	/	/	/	/	/	/	/	/
	5795	802.11 ax40	/	/	/	/	/	/	/	/

Note:

1. When the 1-g SAR is $\leq 0.8W/kg$, testing for other channels are optional.
2. When SAR or MPE is not measured at the maximum power level allowed for production units, the results must be scaled to the maximum tune-up tolerance limit according to the power applied to the individual channels tested to determine compliance.
3. For 802.11ax40 mode power is the largest among 802.11a/n20/n40/ac20/ac40/ac80/ax20/ax40/ax80, 802.11 ax40 mode as initial test configuration is selected to test.

WLAN 5.9G:

EUT Position	Frequency (MHz)	Test Mode	Max. Meas. Power (dBm)	Max. Rated Power (dBm)	Scaled Factor	1g SAR (W/Kg)				
						Duty cycle Factor	Meas.	Scaled SAR	Limit	Plot
Head Left Cheek	/	/	/	/	/	/	/	/	/	/
	5815	802.11 ac160	19.85	20.1	1.059	1.034	1.260	1.38	1.6	67
	/	/	/	/	/	/	/	/	/	/
Head Left Tilt	/	/	/	/	/	/	/	/	/	/
	5815	802.11 ac160	19.85	20.1	1.059	1.034	0.570	0.62	1.6	68
	/	/	/	/	/	/	/	/	/	/
Head Right Cheek	/	/	/	/	/	/	/	/	/	/
	5815	802.11 ac160	19.85	20.1	1.059	1.034	0.475	0.52	1.6	69
	/	/	/	/	/	/	/	/	/	/
Head Right Tilt	/	/	/	/	/	/	/	/	/	/
	5815	802.11 ac160	19.85	20.1	1.059	1.034	0.521	0.57	1.6	70
	/	/	/	/	/	/	/	/	/	/
Body Front (10mm)	/	/	/	/	/	/	/	/	/	/
	5815	802.11 ac160	19.85	20.1	1.059	1.034	0.239	0.26	1.6	71
	/	/	/	/	/	/	/	/	/	/
Body Back (10mm)	/	/	/	/	/	/	/	/	/	/
	5815	802.11 ac160	19.85	20.1	1.059	1.034	0.492	0.54	1.6	72
	/	/	/	/	/	/	/	/	/	/
Body Right (10mm)	/	/	/	/	/	/	/	/	/	/
	5815	802.11 ac160	19.85	20.1	1.059	1.034	0.420	0.46	1.6	73
	/	/	/	/	/	/	/	/	/	/
Body Top (10mm)	/	/	/	/	/	/	/	/	/	/
	5815	802.11 ac160	19.85	20.1	1.059	1.034	0.399	0.44	1.6	74
	/	/	/	/	/	/	/	/	/	/

Note:

1. When the 1-g SAR is $\leq 0.8W/kg$, testing for other channels are optional.
2. When SAR or MPE is not measured at the maximum power level allowed for production units, the results must be scaled to the maximum tune-up tolerance limit according to the power applied to the individual channels tested to determine compliance.
3. For 802.11ac160 mode power is the largest among 802.11a/n20/n40/ac20/ac40/ac80/ac160/ax20/ax40/ax80/ax160, 802.11 ac160 mode as initial test configuration is selected to test.

SAR Measurement Variability

In accordance with published RF Exposure KDB procedure 865664 D01 SAR measurement 100 MHz to 6 GHz v01. These additional measurements are repeated after the completion of all measurements requiring the same head or body tissue-equivalent medium in a frequency band. The test device should be returned to ambient conditions (normal room temperature) with the battery fully charged before it is re-mounted on the device holder for the repeated measurement(s) to minimize any unexpected variations in the repeated results:

- 1) Repeated measurement is not required when the original highest measured SAR is < 0.80 W/kg; steps 2) through 4) do not apply.
- 2) When the original highest measured SAR is ≥ 0.80 W/kg, repeat that measurement once.
- 3) Perform a second repeated measurement only if the ratio of largest to smallest SAR for the original and first repeated measurements is > 1.20 or when the original or repeated measurement is ≥ 1.45 W/kg (~ 10% from the 1-g SAR limit).
- 4) Perform a third repeated measurement only if the original, first or second repeated measurement is ≥ 1.5 W/kg and the ratio of largest to smallest SAR for the original, first and second repeated measurements is > 1.20 .

The Highest Measured SAR Configuration in Each Frequency Band

Head

SAR probe calibration point	Frequency Band	Freq.(MHz)	EUT Position	Meas. SAR (W/kg)		Largest to Smallest SAR Ratio
				Original	Repeated	
2450MHz	WLAN 2.4G	2462	Head Left Cheek	1.190	1.121	1.06
5250MHz	WLAN 5.2G	5240	Head Left Cheek	0.981	0.963	1.02
5250MHz	WLAN 5.3G	5320	Head Left Cheek	1.200	1.170	1.03
5500MHz	WLAN 5.6G	5580	Head Left Cheek	1.330	1.280	1.04
5800MHz	WLAN 5.8G	5745	Head Left Cheek	1.370	1.310	1.05
5800MHz	WLAN 5.9G	5815	Head Left Cheek	1.260	1.210	1.04

Body

SAR probe calibration point	Frequency Band	Freq.(MHz)	EUT Position	Meas. SAR (W/kg)		Largest to Smallest SAR Ratio
				Original	Repeated	
5500MHz	WLAN 5.6G	5500	Body Back	1.080	1.036	1.04

Note:

1. Second Repeated Measurement is not required since the ratio of the largest to smallest SAR for the original and first repeated measurement is not > 1.20 .
2. The measured SAR results **do not** have to be scaled to the maximum tune-up tolerance to determine if repeated measurements are required.
3. SAR measurement variability must be assessed for each frequency band, which is determined by the **SAR probe calibration point and tissue-equivalent medium** used for the device measurements.

SAR SIMULTANEOUS TRANSMISSION DESCRIPTION

The device does not have simultaneous transmission capability.

SAR Plots

Please Refer to the Attachment.

APPENDIX A MEASUREMENT UNCERTAINTY

The uncertainty budget has been determined for the measurement system and is given in the following Table.

Measurement uncertainty evaluation for IEEE1528-2013 SAR test

Source of uncertainty	Tolerance/uncertainty ± %	Probability distribution	Divisor	ci (1 g)	ci (10 g)	Standard uncertainty ± %, (1 g)	Standard uncertainty ± %, (10 g)
Measurement system							
Probe calibration	13.9	N	1	1	1	13.9	13.9
Axial Isotropy	4.7	R	√3	1	1	2.7	2.7
Hemispherical Isotropy	9.6	R	√3	0	0	0.0	0.0
Boundary effect	1.0	R	√3	1	1	0.6	0.6
Linearity	4.7	R	√3	1	1	2.7	2.7
Detection limits	1.0	R	√3	1	1	0.6	0.6
Modulation response	4.0	R	√3	1	1	2.3	2.3
Readout electronics	0.3	N	1	1	1	0.3	0.3
Response time	0.0	R	√3	1	1	0.0	0.0
Integration time	0.0	R	√3	1	1	0.0	0.0
RF ambient conditions – noise	1.0	R	√3	1	1	0.6	0.6
RF ambient conditions–reflections	1.0	R	√3	1	1	0.6	0.6
Probe positioner mech. Restrictions	0.8	R	√3	1	1	0.5	0.5
Probe positioning with respect to phantom shell	6.7	R	√3	1	1	3.9	3.9
Extrapolation, interpolation, and integrations algorithms for max. SAR evaluation	3.9	R	√3	1	1	2.3	2.3
Test sample related							
Test sample positioning	2.8	N	1	1	1	2.8	2.8
Device holder uncertainty	6.3	N	1	1	1	6.3	6.3
Drift of output power	5.0	R	√3	1	1	2.9	2.9
SAR scaling	2.0	R	√3	1	1	1.2	1.2
Phantom and tissue parameters							
Phantom uncertainty (shape and thickness tolerances)	4.0	R	√3	1	1	2.3	2.3
Uncertainty in SAR correction for deviations in permittivity and conductivity	1.9	N	1	1	0.84	1.9	1.6
Liquid conductivity measurement	5.5	N	1	0.78	0.71	4.3	3.9
Liquid permittivity measurement	2.9	N	1	0.23	0.26	0.7	0.8
Liquid conductivity—temperature uncertainty	1.7	R	√3	0.78	0.71	0.8	0.7
Liquid permittivity—temperature uncertainty	2.7	R	√3	0.23	0.26	0.4	0.4
Combined standard uncertainty		RSS				12.2	12.0
Expanded uncertainty 95 % confidence interval)						24.3	23.9

APPENDIX B EUT TEST POSITION PHOTOS

Please Refer to the Attachment.

APPENDIX C PROBE CALIBRATION CERTIFICATES

Please Refer to the Attachment.

******* END OF REPORT *******