



MEASUREMENT REPORT

FCC Part 15B

FCC ID: YZZGXV3275
APPLICANT: Grandstream Networks, Inc.

Product: IP Multimedia Phone
Model No.: GXV3275
Brand Name: Grandstream
FCC Classification: FCC Class B Digital Device (JBP)
FCC Rule Part(s): FCC Part 15 Subpart B: 2014
Test Procedure(s): ANSI C63.4: 2014
Test Date: January 12 ~ 20, 2016

Reviewed By : Robin Wu
(Robin Wu)
Approved By : Marlin Chen
(Marlin Chen)



The test results relate only to the samples tested.

This equipment has been shown to be capable of compliance with the applicable technical standards as indicated in the measurement report and was tested in accordance with the measurement procedures specified in ANSI C63.4-2014. Test results reported herein relate only to the item(s) tested.

The test report shall not be reproduced except in full without the written approval of MRT Technology (Suzhou) Co., Ltd.

Revision History

Report No.	Version	Description	Issue Date
1601RSU01103	Rev. 01	Initial report	01-21-2016
1601RSU01103	Rev. 02	Update the test setup diagram	02-05-2016

Note: The EUT has been got the FCC certificate (FCC ID: YZZGXV3275). The EUT adds one new adapter now and we have shown the conducted emission data and radiated emission data (below 1GHz) in the JBP report.

CONTENTS

Description	Page
§2.1033 General Information	4
1. INTRODUCTION	5
1.1. Scope	5
1.2. MRT Test Location.....	5
2. PRODUCT INFORMATION	6
2.1. Equipment Description.....	6
2.2. Test Mode	6
2.3. Test Configuration	7
2.4. Test System Details.....	7
2.5. Test Software	8
2.6. EMI Suppression Device(s)/Modifications.....	8
3. DESCRIPTION OF TEST	9
3.1. Evaluation Procedure	9
3.2. AC Line Conducted Emissions	9
3.3. Radiated Emissions.....	10
4. TEST EQUIPMENT CALIBRATION DATE	11
5. MEASUREMENT UNCERTAINTY.....	12
6. TEST RESULT	13
6.1. Summary	13
6.2. Conducted Emission Measurement	14
6.2.1. Test Limit	14
6.2.2. Test Setup.....	14
6.2.3. Test Result of Conducted Emissions.....	15
6.3. Radiated Emission Measurement	19
6.3.1. Test Limit	19
6.3.2. Test Frequency selected.....	19
6.3.3. Test Setup.....	20
6.3.4. Test Result of Radiated Emissions.....	21
7. CONCLUSION.....	25

§2.1033 General Information

Applicant:	Grandstream Networks, Inc.
Applicant Address:	4th Floor, Rainbow Technology Building #16 New West Rd, Nanshan Science & Technology Park (North District), Shenzhen, China 518057
Manufacturer:	Grandstream Networks, Inc.
Manufacturer Address:	4th Floor, Rainbow Technology Building #16 New West Rd, Nanshan Science & Technology Park (North District), Shenzhen, China 518057
Test Site:	MRT Technology (Suzhou) Co., Ltd
Test Site Address:	D8 Building, Youxin Industrial Park, No.2 Tian'edang Rd., Wuzhong Economic Development Zone, Suzhou, China
MRT FCC Registration No.:	809388
Model No.:	GXV3275
Test Device Serial No.:	N/A <input type="checkbox"/> Production <input checked="" type="checkbox"/> Pre-Production <input type="checkbox"/> Engineering

Test Facility / Accreditations

Measurements were performed at MRT Laboratory located in Tian'edang Rd., Suzhou, China.

- MRT facility is a FCC registered (MRT Reg. No. 809388) test facility with the site description report on file and has met all the requirements specified in Section 2.948 of the FCC Rules.
- MRT facility is an IC registered (MRT Reg. No. 11384A-1) test laboratory with the site description on file at Industry Canada.
- MRT facility is a VCCI registered (R-4179, G-814, C-4664, T-2206) test laboratory with the site description on file at VCCI Council.
- MRT Lab is accredited to ISO 17025 by the American Association for Laboratory Accreditation (A2LA) under the American Association for Laboratory Accreditation Program (A2LA Cert. No. 3628.01) in EMC, Telecommunications and Radio testing for FCC, Industry Canada, EU and TELEC Rules.



1. INTRODUCTION

1.1. Scope

Measurement and determination of electromagnetic emissions (EMC) of radio frequency devices including intentional and/or unintentional radiators for compliance with the technical rules and regulations of the Federal Communications Commission and the Industry Canada Certification and Engineering Bureau.

1.2. MRT Test Location

The map below shows the location of the MRT LABORATORY, its proximity to the Taihu Lake. These measurement tests were conducted at the MRT Technology (Suzhou) Co., Ltd. Facility located at D8 Building, Youxin Industrial Park, No.2 Tian'edang Rd., Wuzhong Economic Development Zone, Suzhou, China. The detailed description of the measurement facility was found to be in compliance with the requirements of § 2.948 according to ANSI C63.4-2009 on September 30, 2013.



2. PRODUCT INFORMATION

2.1. Equipment Description

Product Name	IP Multimedia Phone
Model No.	GXV3275
Brand Name	Grandstream
802.11a/b/g/n	802.11a/b/g/n
v3.0 + HS, v4.0	v3.0
BT Antenna	Small antenna with 0 ~ 2 dBi peak gain
WiFi Antenna	FPC Antenna, 1T1R
Components	
Adapter #1	M/N: H18US1200150A Input: AC 100-240V ~ 50/60Hz, 0.8A max OUTPUT: 12Vdc, 1.5A
Adapter #2	M/N: F18W8-120150SPAUY Input: AC 100-240V ~ 50/60Hz, 0.6A OUTPUT: 12Vdc, 1.5A

2.2. Test Mode

Pre-Test Mode	
EMI Mode	Mode 1: Audio Call with another IP Multimedia Phone, Communicate with PC and HDMI Out, Powered by Adapter #1
	Mode 2: Audio Call with another IP Multimedia Phone, Communicate with PC and HDMI Out, Powered by Adapter #2
	Mode 3: Video Call with another IP Multimedia Phone, Communicate with PC and HDMI Out, Powered by Adapter #1
	Mode 4: Video Call with another IP Multimedia Phone, Communicate with PC and HDMI Out, Powered by Adapter #2
Final Test Mode	
EMI Mode	Mode 3: Video Call with another IP Multimedia Phone, Communicate with PC and HDMI Out, Powered by Adapter #1
	Mode 4: Video Call with another IP Multimedia Phone, Communicate with PC and HDMI Out, Powered by Adapter #2

2.3. Test Configuration

The EUT was tested per the guidance FCC Part 15 Subpart B: 2014 and ANSI C63.4: 2014 was used to reference the appropriate EUT setup for radiated spurious emissions testing and AC line conducted testing.

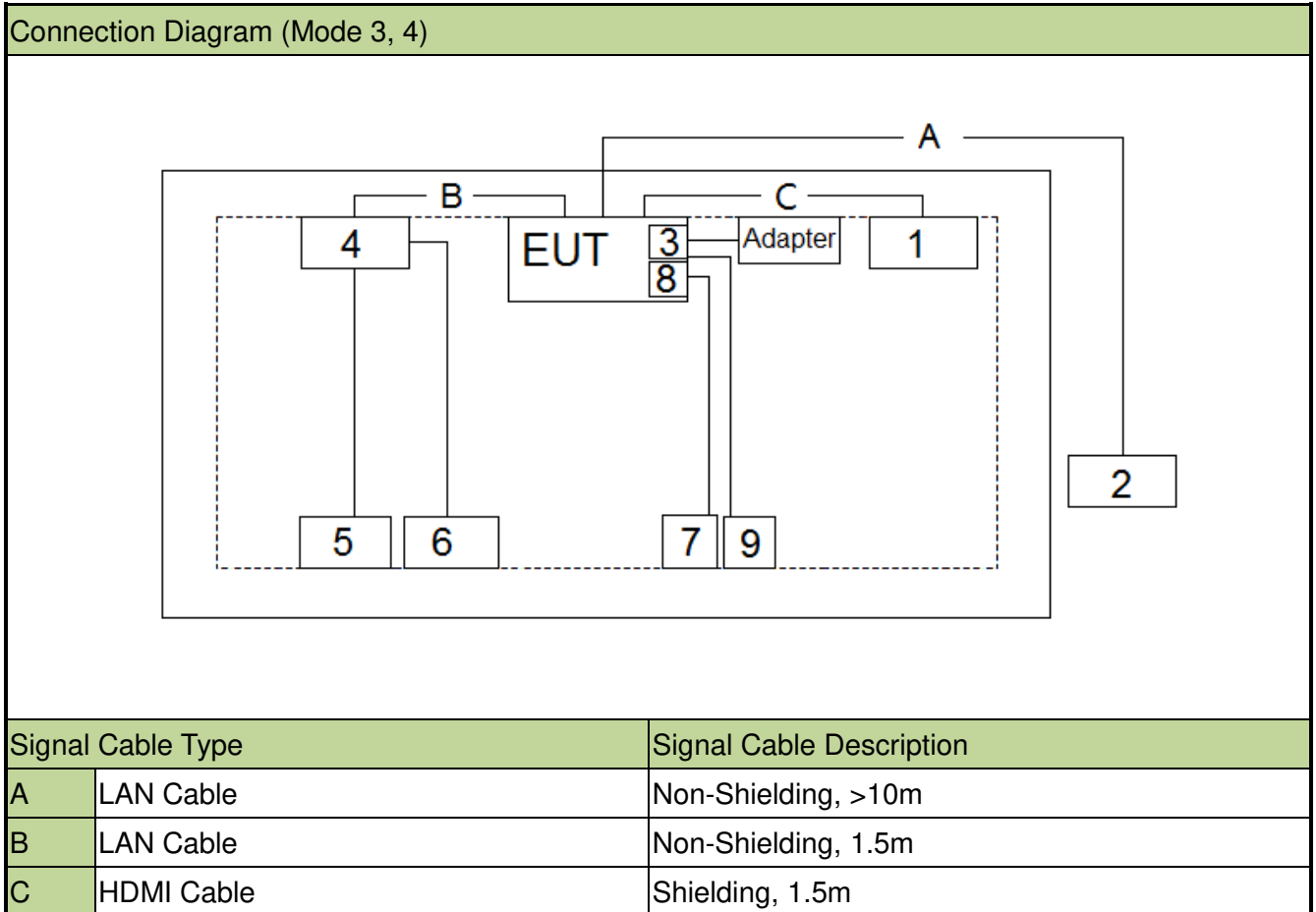

2.4. Test System Details

The types for all equipments, plus descriptions of all cables used in the tested system (including inserted cards) are:

Product	Manufacturer	Model No.	Serial No.	Power Cord	
1	Television	Sony	KDL-40RM10B	2007861	Non-Shielded, 1.8m
2	IP Phone	Grandstream	GXV3240	N/A	N/A
3	SDHC Card	SanDisk	N/A	N/A	N/A
4	Notebook	Lenovo	X201	3626AM3	Non-Shielded, 1.8m
5	USB Keyboard	Dell	KB212	N/A	N/A
6	USB Mouse	Dell	MS111	N/A	N/A
7	USB Mouse	Dell	MS111	N/A	N/A
8	Flash Disk	Kingston	N/A	N/A	N/A

9	EarPods	Apple	N/A	N/A	N/A
---	---------	-------	-----	-----	-----

Remark: The auxiliary equipment notebook was authorized by FCC Declaration of Confirmation.

2.5. Test Software

1	Setup the EUT and simulators as shown on above.
2	(1), Make the EUT set-up as shown above. (2), Power on the EUT and works in "Video Call with another IP Multimedia Phone, Communicate with PC and HDMI Out Mode". (3), Start to test.

2.6. EMI Suppression Device(s)/Modifications

No EMI suppression device(s) were added and/or no modifications were made during testing.

3. DESCRIPTION OF TEST

3.1. Evaluation Procedure

The measurement procedures described in the American National Standard for Methods of Measurement of Radio-Noise Emission from Low-Voltage Electrical Equipment in the Range of 9kHz to 40GHz (ANSI C63.4-2014) was used in the measurement of the **IP Multimedia Phone**

Deviation from measurement procedure.....None

3.2. AC Line Conducted Emissions

The line-conducted facility is located inside an 8'x4'x4' shielded enclosure. A 1m x 2m wooden table 80cm high is placed 40cm away from the vertical wall and 80cm away from the sidewall of the shielded room. Two 10kHz-30MHz, 50Ω/50uH Line-Impedance Stabilization Networks (LISNs) are bonded to the shielded room floor. Power to the LISNs is filtered by external high-current high-insertion loss power line filters. These filters attenuate ambient signal noise from entering the measurement lines. These filters are also bonded to the shielded enclosure.

The EUT is powered from one LISN and the support equipment is powered from the second LISN. If the EUT is a DC-powered device, power will be derived from the source power supply it normally will be powered from and this supply line(s) will be connected to the second LISN. All interconnecting cables more than 1 meter were shortened to a 1 meter length by non-inductive bundling (serpentine fashion) and draped over the back edge of the test table. All cables were at least 40cm above the horizontal reference ground-plane. Power cables for support equipment were routed down to the second LISN while ensuring that that cables were not draped over the second LISN.

Sufficient time for the EUT, support equipment, and test equipment was allowed in order for them to warm up to their normal operating condition. The RF output of the LISN was connected to the receiver and exploratory measurements were made to determine the frequencies producing the maximum emission from the EUT. The receiver was scanned from 150 kHz to 30 MHz. The detector function was set to peak mode for exploratory measurements while the bandwidth of the analyzer was set to 9 kHz. The EUT, support equipment, and interconnecting cables were arranged and manipulated to maximize each emission. Each emission was also maximized by varying: power lines, the mode of operation or resolution, clock or data exchange speed, scrolling H pattern to the EUT and/or support equipment whichever determined the worst-case emission. Once the worst case emissions have been identified, the one EUT cable configuration/arrangement and mode of operation that produced these emissions are used for final measurements on the same test site. Line conducted emissions test results are shown in Section 6.2.

3.3. Radiated Emissions

The radiated test facilities consisted of an indoor 3 meter semi-anechoic chamber used for final measurements and exploratory measurements, when necessary. The measurement area is contained within the semi-anechoic chamber which is shielded from any ambient interference. For measurements above 1GHz absorbers are arranged on the floor between the turn table and the antenna mast in such a way so as to maximize the reduction of reflections. For measurements below 1GHz, the absorbers are removed. An MF Model 210SS turntable is used for radiated measurement. It is a continuously rotatable, remote controlled, metallic turntable and 2 meters (6.56 ft.) in diameter. The turn table is flush with the raised floor of the chamber in order to maintain its function as a ground plane. An 80cm high PVC support structure is placed on top of the turntable.

For all measurements, the spectrum was scanned through all EUT azimuths and from 1 to 4 meter receive antenna height using a broadband antenna from 30 MHz up to the upper frequency shown in 15.33(b)(1) depending on the highest frequency generated or used in the device or on which the device operates or tunes. For frequencies above 1GHz, linearly polarized double ridge horn antennas were used. For frequencies below 30 MHz, a calibrated loop antenna was used. When exploratory measurements were necessary, they were performed at 1 meter test distance inside the semi-anechoic chamber using broadband antennas, broadband amplifiers, and spectrum analyzers to determine the frequencies and modes producing the maximum emissions. Sufficient time for the EUT, support equipment, and test equipment was allowed in order for them to warm up to their normal operating condition. The test set-up was placed on top of the 0.8 meter high, 1 x 1.5 meter table. The EUT, support equipment, and interconnecting cables were arranged and manipulated to maximize each emission. Appropriate precaution was taken to ensure that all emissions from the EUT were maximized and investigated. The system configuration, mode of operation, if applicable, turntable azimuth, and receive antenna height was noted for each frequency found.

Final measurements were made in the semi-anechoic chamber using calibrated, linearly polarized broadband and horn antennas. The test setup was configured to the setup that produced the worst case emissions. The spectrum analyzer was set to investigate all frequencies required for testing to compare the highest radiated disturbances with respect to the specified limits. The turntable containing the EUT was rotated through 360 degrees and the height of the receive antenna was varied 1 to 4 meters and stopped at the azimuth and height producing the maximum emission. Each emission was maximized by changing the orientation of the EUT through three orthogonal planes and changing the polarity of the receive antenna, whichever produced the worst-case emissions. According to 3dB beam-width of horn antenna, the horn antenna should be always directed to the EUT when rising height.

4. TEST EQUIPMENT CALIBRATION DATE

Conducted Emissions - SR2

Instrument	Manufacturer	Type No.	Asset No.	Cali. Interval	Cali. Due Date
EMI Test Receiver	R&S	ESR7	MRTSUE06001	1 year	2016/11/03
Two-Line V-Network	R&S	ENV216	MRTSUE06002	1 year	2016/11/03
Two-Line V-Network	R&S	ENV216	MRTSUE06003	1 year	2016/11/03
Temperature/ Meter Humidity	Yuhuaze	N/A	MRTSUE06180	1 year	2016/12/20

Radiated Emissions - AC2

Instrument	Manufacturer	Type No.	Asset No.	Cali. Interval	Cali. Due Date
Spectrum Analyzer	Agilent	N9010A	MRTSUE06124	1 year	2016/06/23
EMI Test Receiver	R&S	ESR7	MRTSUE06001	1 year	2016/11/03
TRILOG Antenna	Schwarzbeck	VULB9168	MRTSUE06172	1 year	2016/12/10
Temperature/ Meter Humidity	Mingao	ETH529	MRTSUE06170	1 year	2016/11/29

Software	Version	Function
e3	V 8.3.5	EMI Test Software

5. MEASUREMENT UNCERTAINTY

Where relevant, the following test uncertainty levels have been estimated for tests performed on the EUT as specified in CISPR 16-4-2. This uncertainty represents an expanded uncertainty expressed at approximately the 95% confidence level using a coverage factor of $k = 2$.

AC Conducted Emission Measurement
Measuring Uncertainty for a Level of Confidence of 95% ($U=2Uc(y)$): 150kHz~30MHz: 3.5dB
Radiated Emission Measurement
Measuring Uncertainty for a Level of Confidence of 95% ($U=2Uc(y)$): Horizontal: 30MHz~1GHz: 4.07dB Vertical: 30MHz~1GHz: 4.18 dB

6. TEST RESULT

6.1. Summary

Company Name: Grandstream Networks, Inc.

Test Mode: Video Call with another IP Multimedia Phone, Communicate with PC and HDMI Out Mode;

FCC Part Section(s)	Test Description	Test Result
15.107	Conducted Emissions	Pass
15.109	Radiated Emissions	Pass

6.2. Conducted Emission Measurement

6.2.1. Test Limit

FCC Part 15.107 Limits		
Frequency (MHz)	QP (dB μ V)	AV (dB μ V)
0.15 - 0.50	66 - 56	56 - 46
0.50 - 5.0	56	46
5.0 - 30	60	50

Note 1: The lower limit shall apply at the transition frequencies.

Note 2: The limit decreases linearly with the logarithm of the frequency in the range 0.15MHz to 0.5MHz.

6.2.2. Test Setup

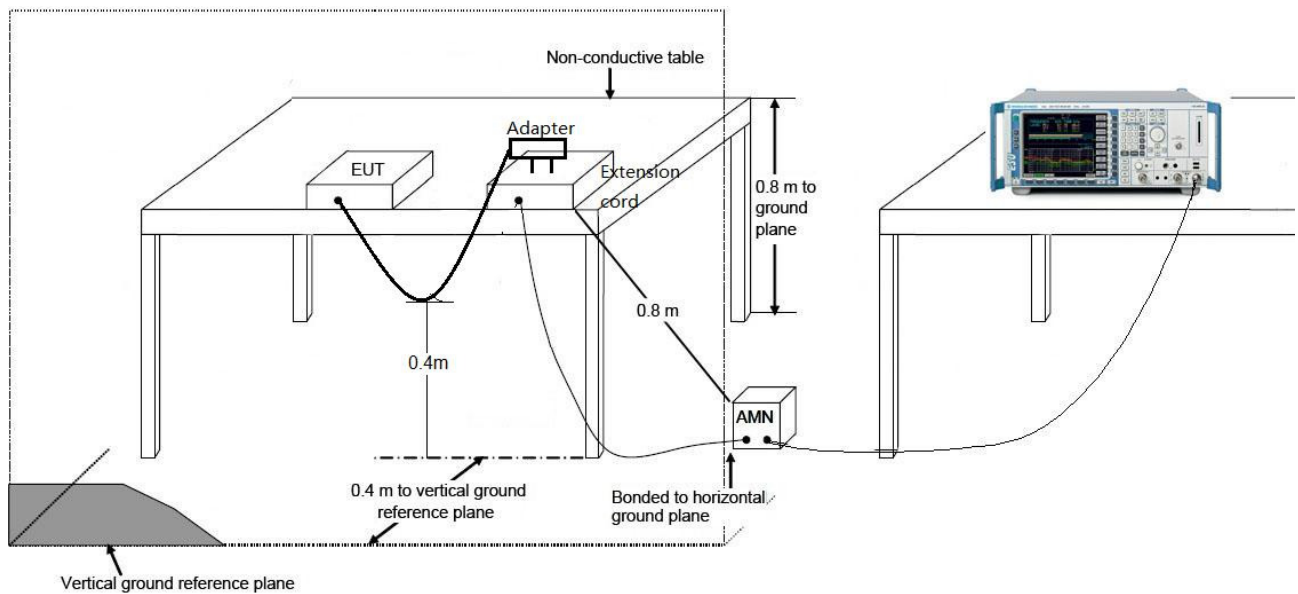

6.2.3. Test Result of Conducted Emissions

Site: SR2	Time: 2016/01/12 - 17:06
Limit: FCC_Part15.107_CE_AC Power_Class B	Engineer: Vince Yu
Probe: ENV216_101683_Filter On	Polarity: Line
EUT: IP Multimedia Phone	Power: AC 120V/60Hz
Note: Mode 3	

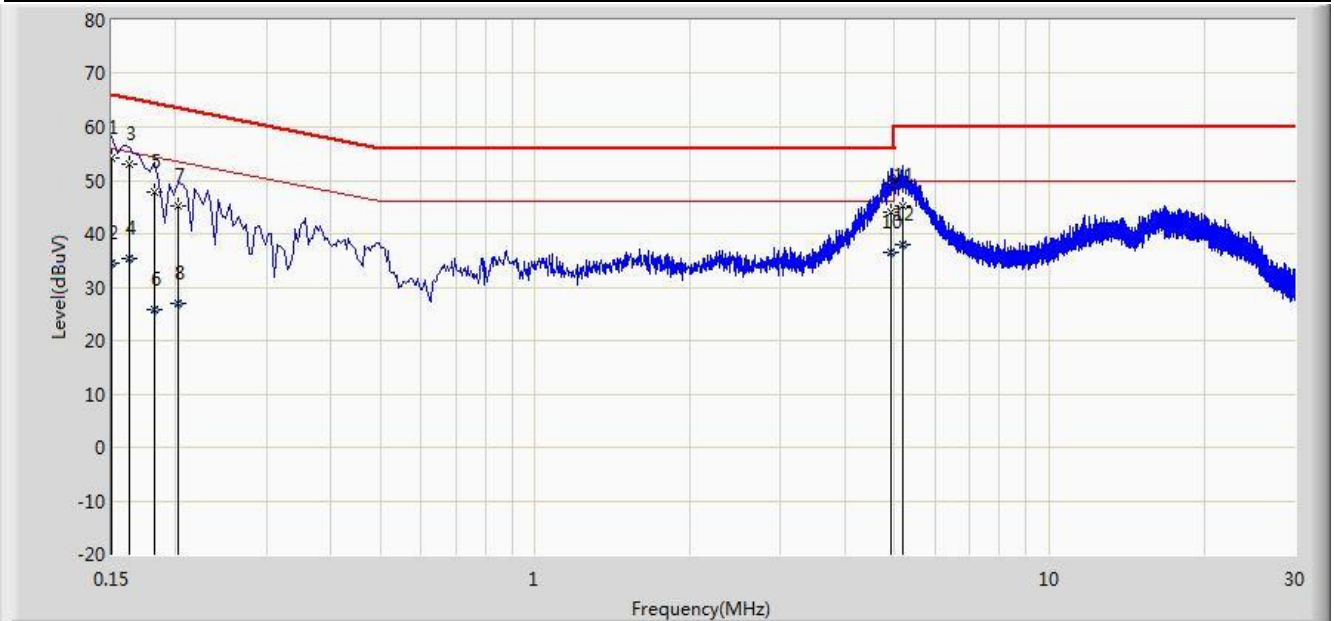

No	Flag	Mark	Frequency (MHz)	Measure Level (dBuV)	Reading Level (dBuV)	Over Limit (dB)	Limit (dBuV)	Factor (dB)	Type
1			0.150	54.208	43.039	-11.792	66.000	11.168	QP
2			0.150	34.561	23.393	-21.439	56.000	11.168	AV
3			0.162	52.942	42.845	-12.419	65.361	10.097	QP
4			0.162	35.494	25.397	-19.867	55.361	10.097	AV
5			0.182	47.908	37.860	-16.486	64.394	10.048	QP
6			0.182	25.768	15.720	-28.626	54.394	10.048	AV
7			0.202	45.355	35.363	-18.172	63.528	9.993	QP
8			0.202	26.915	16.922	-26.613	53.528	9.993	AV
9			4.910	44.024	34.000	-11.976	56.000	10.024	QP
10		*	4.910	36.380	26.356	-9.620	46.000	10.024	AV
11			5.202	45.149	35.104	-14.851	60.000	10.045	QP
12			5.202	37.923	27.878	-12.077	50.000	10.045	AV

Note: Measure Level (dBμV) = Reading Level (dBμV) + Factor (dB)

Factor (dB) = Cable Loss (dB) + LISN Factor (dB).

Site: SR2	Time: 2016/01/12 - 17:11
Limit: FCC_Part15.107_CE_AC Power_Class B	Engineer: Vince Yu
Probe: ENV216_101683_Filter On	Polarity: Neutral
EUT: IP Multimedia Phone	Power: AC 120V/60Hz
Note: Mode 3	

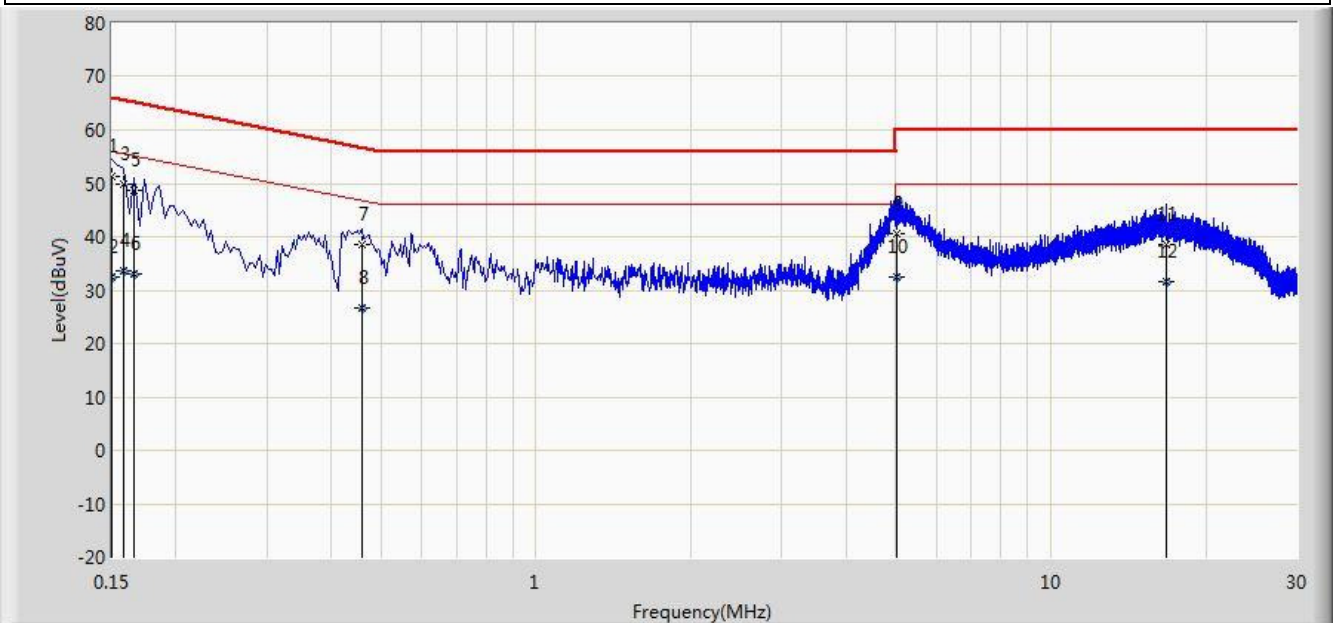

No	Flag	Mark	Frequency (MHz)	Measure Level (dBuV)	Reading Level (dBuV)	Over Limit (dB)	Limit (dBuV)	Factor (dB)	Type
1		*	0.150	51.173	40.031	-14.827	66.000	11.142	QP
2			0.150	32.380	21.238	-23.620	56.000	11.142	AV
3			0.158	49.912	39.622	-15.657	65.568	10.290	QP
4			0.158	33.507	23.217	-22.062	55.568	10.290	AV
5			0.166	48.660	38.589	-16.498	65.158	10.071	QP
6			0.166	32.900	22.829	-22.258	55.158	10.071	AV
7			0.458	38.487	28.332	-18.241	56.729	10.156	QP
8			0.458	26.623	16.467	-20.106	46.729	10.156	AV
9			5.014	40.530	30.489	-19.470	60.000	10.041	QP
10			5.014	32.413	22.372	-17.587	50.000	10.041	AV
11			16.750	38.684	28.571	-21.316	60.000	10.113	QP
12			16.750	31.656	21.543	-18.344	50.000	10.113	AV

Note: Measure Level (dBμV) = Reading Level (dBμV) + Factor (dB)

Factor (dB) = Cable Loss (dB) + LISN Factor (dB).

Site: SR2	Time: 2016/01/12 - 18:46
Limit: FCC_Part15.107_CE_AC Power_Class B	Engineer: Vince Yu
Probe: ENV216_101683_Filter On	Polarity: Line
EUT: IP Multimedia Phone	Power: AC 120V/60Hz
Note: Mode 4	

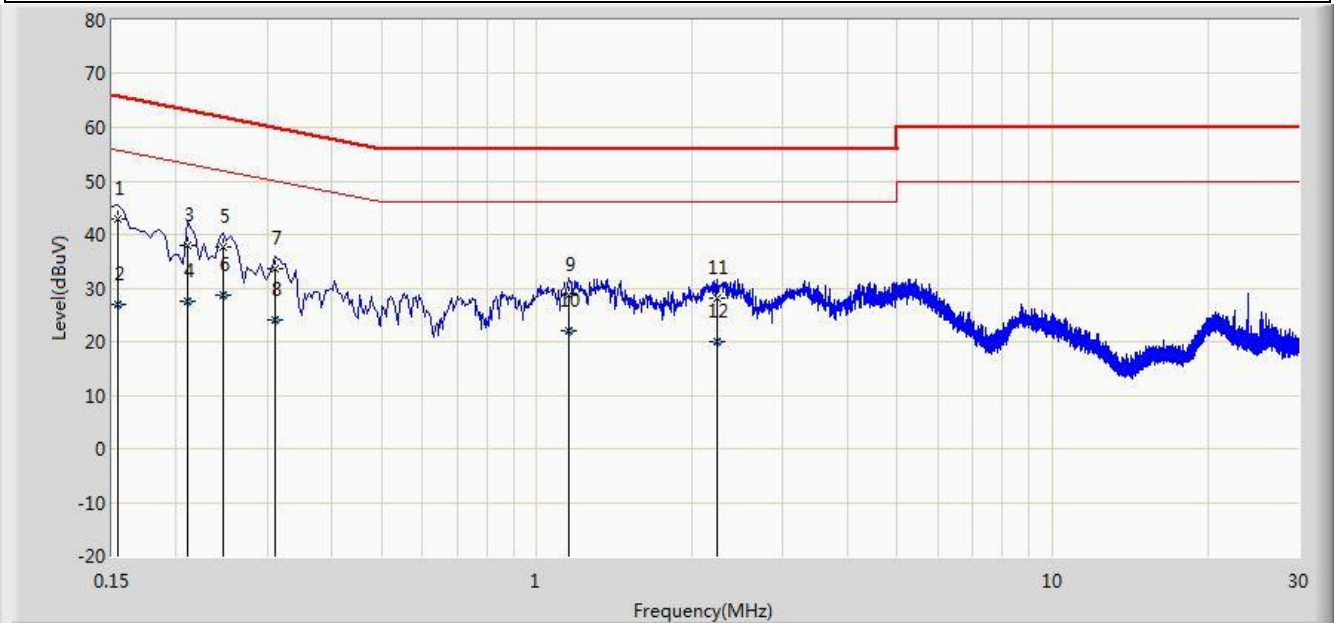

No	Flag	Mark	Frequency (MHz)	Measure Level (dBuV)	Reading Level (dBuV)	Over Limit (dB)	Limit (dBuV)	Factor (dB)	Type
1		*	0.154	42.918	32.178	-22.863	65.781	10.740	QP
2			0.154	26.943	16.203	-28.839	55.781	10.740	AV
3			0.210	37.917	27.948	-25.288	63.205	9.969	QP
4			0.210	27.548	17.579	-25.657	53.205	9.969	AV
5			0.246	37.651	27.690	-24.241	61.891	9.961	QP
6			0.246	28.726	18.765	-23.165	51.891	9.961	AV
7			0.310	33.730	23.718	-26.240	59.970	10.012	QP
8			0.310	24.006	13.994	-25.964	49.970	10.012	AV
9			1.154	28.770	18.866	-27.230	56.000	9.904	QP
10			1.154	22.080	12.177	-23.920	46.000	9.904	AV
11			2.242	28.059	18.194	-27.941	56.000	9.864	QP
12			2.242	20.135	10.270	-25.865	46.000	9.864	AV

Note: Measure Level (dBμV) = Reading Level (dBμV) + Factor (dB)

Factor (dB) = Cable Loss (dB) + LISN Factor (dB).

Site: SR2	Time: 2016/01/12 - 18:54
Limit: FCC_Part15.107_CE_AC Power_Class B	Engineer: Vince Yu
Probe: ENV216_101683_Filter On	Polarity: Neutral
EUT: IP Multimedia Phone	Power: AC 120V/60Hz
Note: Mode 4	

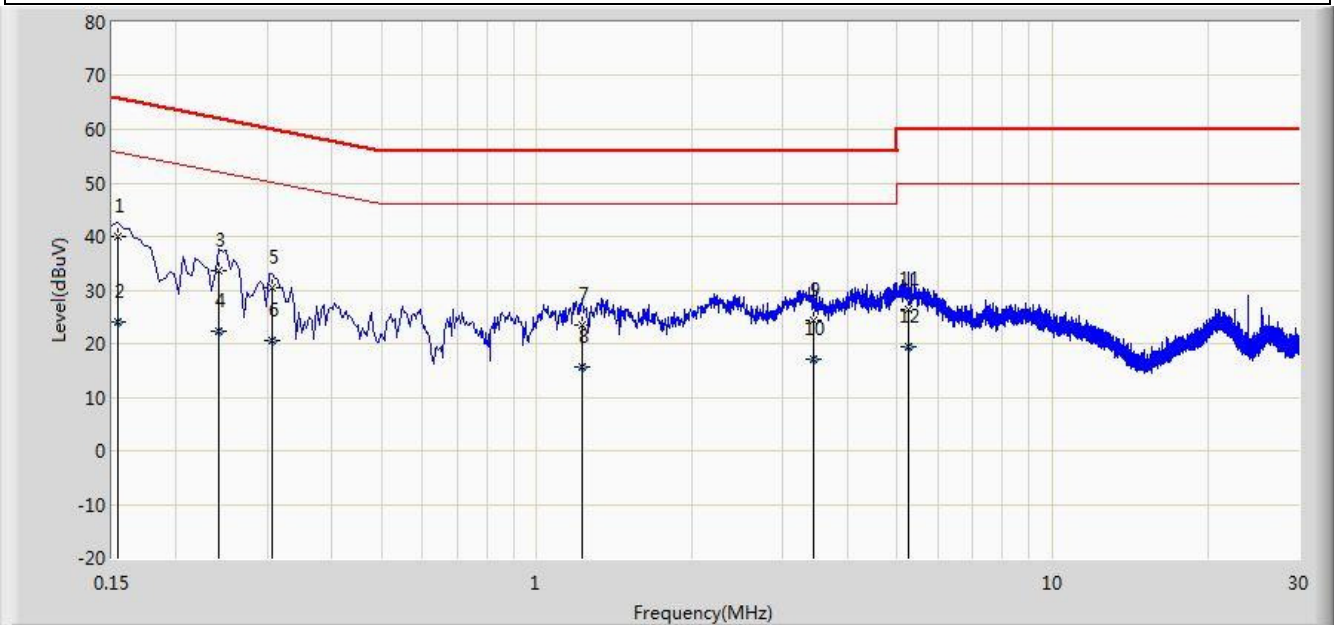

No	Flag	Mark	Frequency (MHz)	Measure Level (dBuV)	Reading Level (dBuV)	Over Limit (dB)	Limit (dBuV)	Factor (dB)	Type
1		*	0.154	39.906	29.190	-25.876	65.781	10.716	QP
2			0.154	24.067	13.351	-31.715	55.781	10.716	AV
3			0.242	33.712	23.717	-28.315	62.027	9.995	QP
4			0.242	22.331	12.336	-29.696	52.027	9.995	AV
5			0.306	30.357	20.315	-29.721	60.078	10.042	QP
6			0.306	20.658	10.616	-29.420	50.078	10.042	AV
7			1.226	23.466	13.565	-32.534	56.000	9.901	QP
8			1.226	15.717	5.816	-30.283	46.000	9.901	AV
9			3.450	24.360	14.450	-31.640	56.000	9.910	QP
10			3.450	17.000	7.089	-29.000	46.000	9.910	AV
11			5.246	26.283	16.228	-33.717	60.000	10.054	QP
12			5.246	19.435	9.381	-30.565	50.000	10.054	AV

Note: Measure Level (dBμV) = Reading Level (dBμV) + Factor (dB)

Factor (dB) = Cable Loss (dB) + LISN Factor (dB).

6.3. Radiated Emission Measurement

6.3.1. Test Limit

FCC Part 15.109 Limits		
Frequency (MHz)	Distance (m)	Level (dB μ V/m)
30 - 88	3	40
88 - 216	3	43.5
216 - 960	3	46
Above 960	3	54

Note 1: The lower limit shall apply at the transition frequency.

Note 2: Distance refers to the distance in meters between the measuring instrument antenna and the closed point of any part of the device or system.

Note 3: E field strength (dB μ V/m) = 20 log E field strength (uV/m)

6.3.2. Test Frequency selected

For an unintentional radiator, including a digital device, the spectrum shall be investigated from the lowest radio frequency signal generated or used in the device, without going below the lowest frequency for which a radiated emission limit is specified, up to the frequency shown in the following table:

Highest frequency generated or used in the device or on which the device operates or tunes (MHz)	Upper frequency of measurement range (MHz)
Below 1.705	30
1.705 - 108	1000
108 - 500	2000
500 - 1000	5000
Above 1000	5th harmonic of the highest frequency or 40 GHz, whichever is lower

6.3.3. Test Setup

30MHz ~ 1GHz Test Setup:

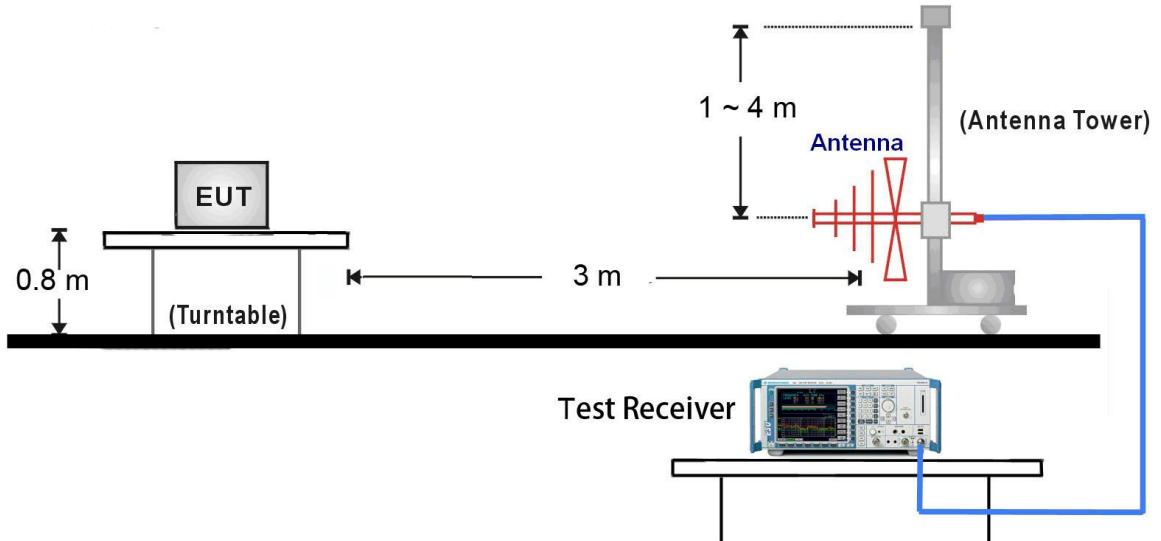

6.3.4. Test Result of Radiated Emissions

Site: AC2	Time: 2016/01/20 - 15:45
Limit: FCC_Part15.109_RE(3m)_Class B	Engineer: Lewis Huang
Probe: VULB9162_0.03-8GHz	Polarity: Horizontal
EUT: IP Multimedia Phone	Power: AC 120V/60Hz
Note: Mode 3	

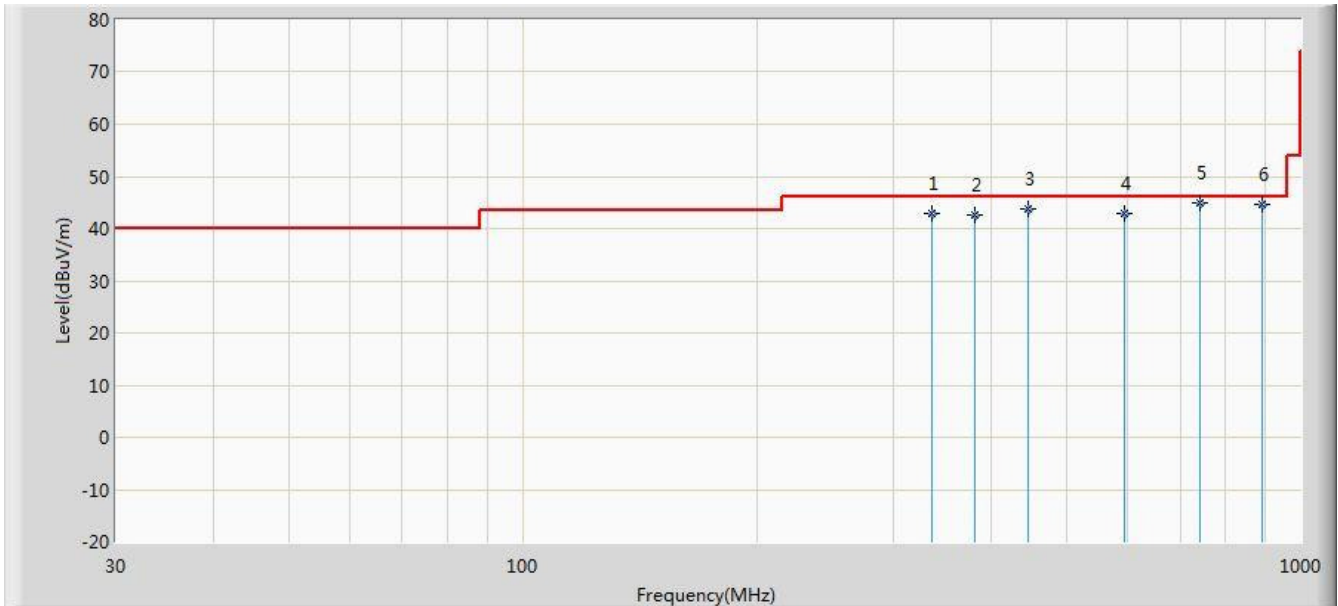

No	Flag	Mark	Frequency (MHz)	Measure Level (dBuV/m)	Reading Level (dBuV)	Over Limit (dB)	Limit (dBuV/m)	Factor (dB)	Type
1			336.035	42.867	27.297	-3.133	46.000	15.570	QP
2			381.625	42.639	26.298	-3.361	46.000	16.341	QP
3			445.645	43.675	26.319	-2.325	46.000	17.356	QP
4			594.055	42.960	22.952	-3.040	46.000	20.008	QP
5		*	742.465	44.833	22.658	-1.167	46.000	22.175	QP
6			890.875	44.778	20.710	-1.222	46.000	24.068	QP

Note: Measure Level (dBuV/m) = Reading Level (dBuV) + Factor (dB)

Factor (dB) = Cable Loss (dB) + Antenna Factor (dB/m).

Site: AC2	Time: 2016/01/20 - 15:45
Limit: FCC_Part15.109_RE(3m)_Class B	Engineer: Lewis Huang
Probe: VULB9162_0.03-8GHz	Polarity: Vertical
EUT: IP Multimedia Phone	Power: AC 120V/60Hz
Note: Mode 3	

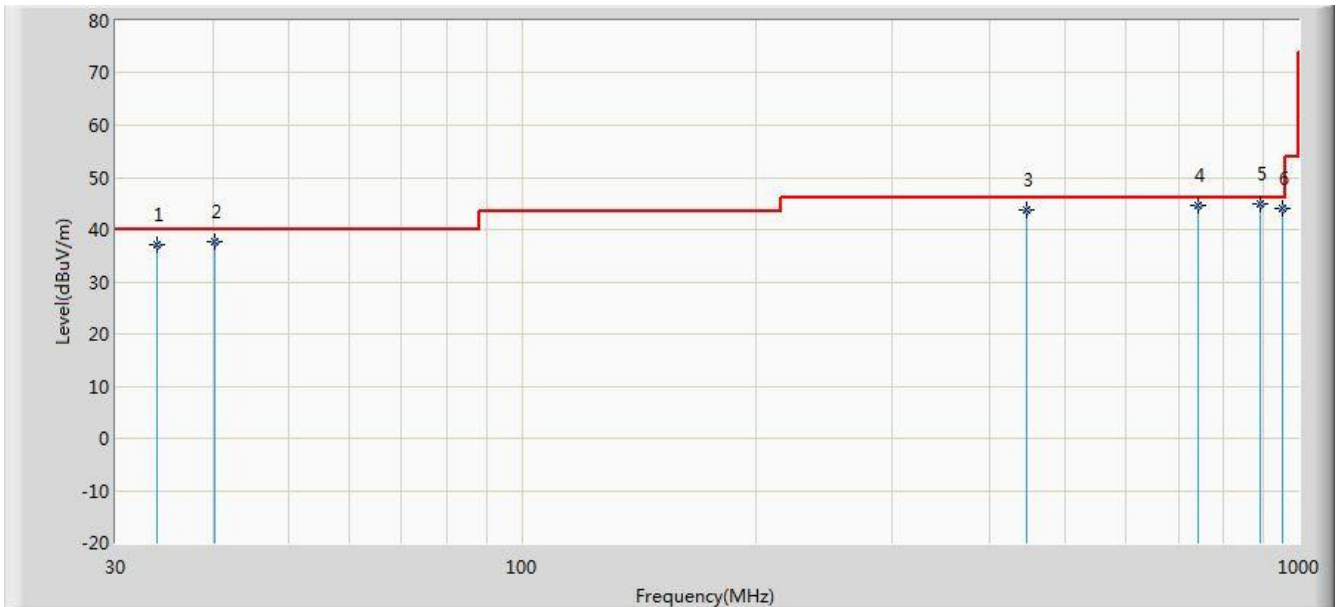

No	Flag	Mark	Frequency (MHz)	Measure Level (dBuV/m)	Reading Level (dBuV)	Over Limit (dB)	Limit (dBuV/m)	Factor (dB)	Type
1			33.880	36.990	24.250	-3.010	40.000	12.740	QP
2			40.185	37.578	23.680	-2.422	40.000	13.898	QP
3			445.645	43.851	26.495	-2.149	46.000	17.356	QP
4			742.465	44.782	22.607	-1.218	46.000	22.175	QP
5		*	890.875	44.973	20.905	-1.027	46.000	24.068	QP
6			954.895	43.967	19.415	-2.033	46.000	24.552	QP

Note: Measure Level (dBuV/m) = Reading Level (dBuV) + Factor (dB)

Factor (dB) = Cable Loss (dB) + Antenna Factor (dB/m).

Site: AC2	Time: 2016/01/20 - 15:46
Limit: FCC_Part15.109_RE(3m)_Class B	Engineer: Lewis Huang
Probe: VULB9162_0.03-8GHz	Polarity: Horizontal
EUT: IP Multimedia Phone	Power: AC 120V/60Hz
Note: Mode 4	

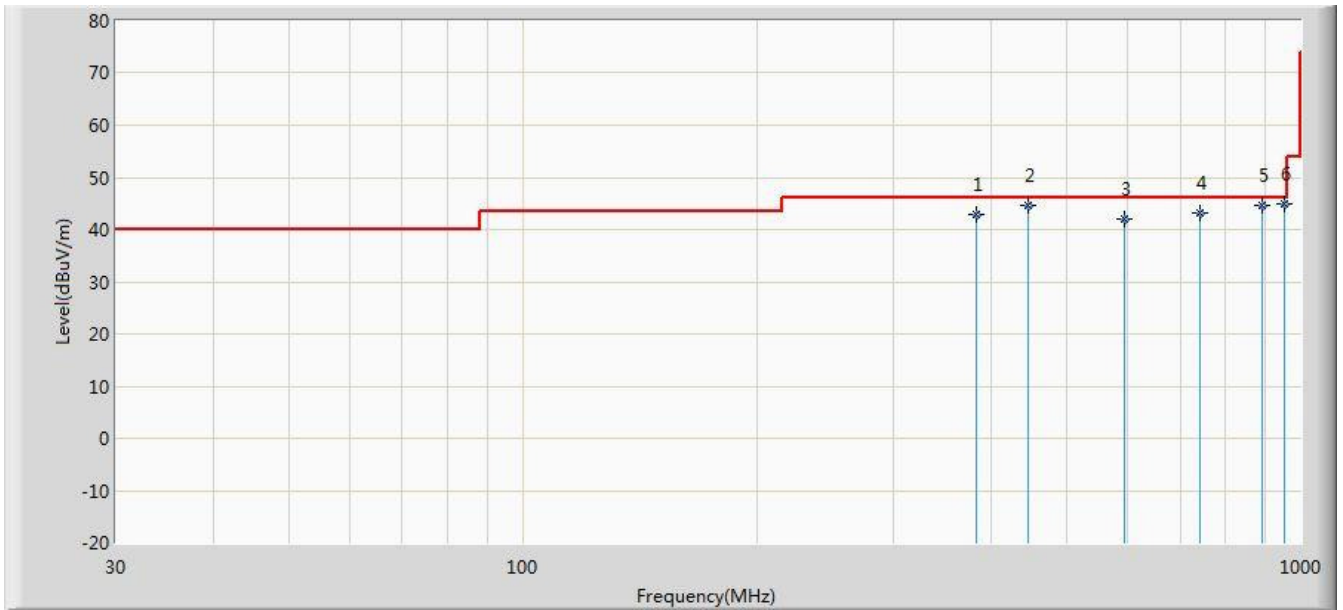

No	Flag	Mark	Frequency (MHz)	Measure Level (dBuV/m)	Reading Level (dBuV)	Over Limit (dB)	Limit (dBuV/m)	Factor (dB)	Type
1			382.110	42.796	26.444	-3.204	46.000	16.352	QP
2			445.645	44.767	27.411	-1.233	46.000	17.356	QP
3			594.055	42.042	22.034	-3.958	46.000	20.008	QP
4			742.465	43.199	21.024	-2.801	46.000	22.175	QP
5			890.390	44.757	20.690	-1.243	46.000	24.067	QP
6		*	954.410	44.924	20.377	-1.076	46.000	24.547	QP

Site: AC2	Time: 2016/01/20 - 15:46
Limit: FCC_Part15.109_RE(3m)_Class B	Engineer: Lewis Huang
Probe: VULB9162_0.03-8GHz	Polarity: Vertical
EUT: IP Multimedia Phone	Power: AC 120V/60Hz
Note: Mode 4	

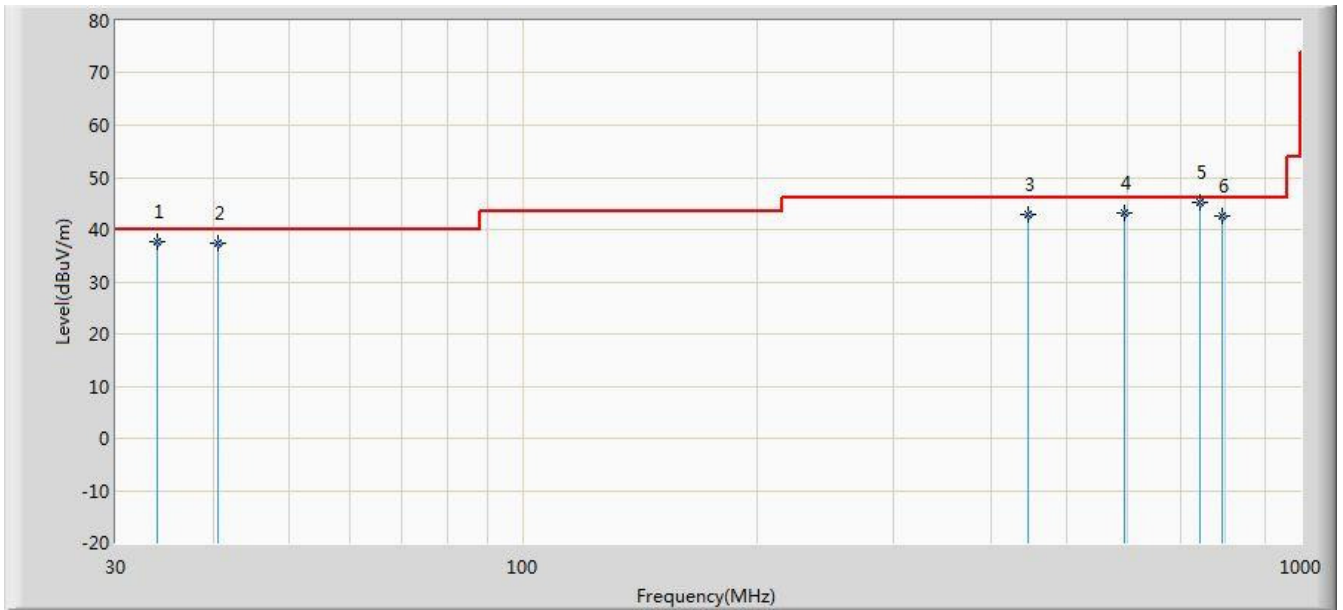

No	Flag	Mark	Frequency (MHz)	Measure Level (dBuV/m)	Reading Level (dBuV)	Over Limit (dB)	Limit (dBuV/m)	Factor (dB)	Type
1			33.880	37.617	24.877	-2.383	40.000	12.740	QP
2			40.670	37.529	23.539	-2.471	40.000	13.989	QP
3			445.645	42.904	25.548	-3.096	46.000	17.356	QP
4			594.055	43.205	23.197	-2.795	46.000	20.008	QP
5		*	742.465	45.157	22.982	-0.843	46.000	22.175	QP
6			791.935	42.506	19.745	-3.494	46.000	22.761	QP

7. CONCLUSION

The data collected relate only the item(s) tested and show that the **IP Multimedia Phone FCC ID: YZZGXV3275** has been tested to comply with the requirements specified in §15.107 and §15.109 of the FCC Rules.

————— The End —————