



MEASUREMENT REPORT

FCC PART 15.247 Bluetooth v3.0 + HS

FCC ID: YZZGXV3275

APPLICANT: Grandstream Networks, Inc.

Application Type: Certification

Product: IP Multimedia Phone

Model No.: GXV3275

Brand Name: Grandstream

FCC Classification: FCC Part 15 Spread Spectrum Transmitter(DSS)

FCC Rule Part(s): Part 15.247

Test Procedure(s): ANSI C63.10-2013, DA 00-705

Test Date: January 12 ~ 20, 2016

Reviewed By : Robin Wu
(Robin Wu)

Approved By : Marlin Chen
(Marlin Chen)



The test results relate only to the samples tested.

This equipment has been shown to be capable of compliance with the applicable technical standards as indicated in the measurement report and was tested in accordance with the measurement procedures specified in ANSI C63.10-2013 and DA 00-705. Test results reported herein relate only to the item(s) tested.

The test report shall not be reproduced except in full without the written approval of MRT Technology (Suzhou) Co., Ltd.

Revision History

Report No.	Version	Description	Issue Date
1601RSU01101	Rev. 01	Initial report	01-21-2016

Note: The EUT has been got the FCC certificate (FCC ID: YZZGXV3275). The EUT adds one new adapter now and we have shown the conducted emission data and radiated emission data (below 1GHz) in the DSS report.

CONTENTS

Description	Page
1. INTRODUCTION	5
1.1. Scope	5
1.2. MRT Test Location	5
2. PRODUCT INFORMATION	6
2.1. Equipment Description.....	6
2.2. Product Specification Subjective to this Standard	7
2.3. Operation Frequency / Channel List	8
2.4. Pseudorandom Frequency Hopping Sequence.....	9
2.5. Test Configuration	9
2.6. Test Software	9
2.7. EMI Suppression Device(s)/Modifications.....	9
3. DESCRIPTION of TEST	10
3.1. Evaluation Procedure	10
3.2. AC Line Conducted Emissions	10
3.3. Radiated Emissions	11
4. TEST EQUIPMENT CALIBRATION DATE	12
5. MEASUREMENT UNCERTAINTY	13
6. TEST RESULT	14
6.1. Summary	14
6.2. Radiated Spurious Emission Measurement	15
6.2.1. Test Limit	15
6.2.2. Test Procedure Used	15
6.2.3. Test Setting	15
6.2.4. Test Setup.....	16
6.2.5. Test Result.....	17
6.3. AC Conducted Emissions Measurement.....	21
6.3.1. Test Limit	21
6.3.2. Test Setup.....	21
6.3.3. Test Result.....	22
7. CONCLUSION.....	26

§2.1033 General Information

Applicant:	Grandstream Networks, Inc.
Applicant Address:	4th Floor, Rainbow Technology Building #16 New West Rd, Nanshan Science & Technology Park (North District), Shenzhen, China 518057
Manufacturer:	Grandstream Networks, Inc.
Manufacturer Address:	4th Floor, Rainbow Technology Building #16 New West Rd, Nanshan Science & Technology Park (North District), Shenzhen, China 518057
Test Site:	MRT Technology (Suzhou) Co., Ltd
Test Site Address:	D8 Building, Youxin Industrial Park, No.2 Tian'edang Rd., Wuzhong Economic Development Zone, Suzhou, China
MRT Registration No.:	809388
FCC Rule Part(s):	Part 15.247
Model No.	GXV3275
FCC ID:	YZZGXV3275
Test Device Serial No.:	N/A <input type="checkbox"/> Production <input checked="" type="checkbox"/> Pre-Production <input type="checkbox"/> Engineering
FCC Classification:	FCC Part 15 Spread Spectrum Transmitter (DSS)

Test Facility / Accreditations

Measurements were performed at MRT Laboratory located in Tian'edang Rd., Suzhou, China.

- MRT facility is a FCC registered (MRT Reg. No. 809388) test facility with the site description report on file and has met all the requirements specified in Section 2.948 of the FCC Rules.
- MRT facility is an IC registered (MRT Reg. No. 11384A-1) test laboratory with the site description on file at Industry Canada.
- MRT facility is a VCCI registered (R-4179, G-814, C-4664, T-2206) test laboratory with the site description on file at VCCI Council.
- MRT Lab is accredited to ISO 17025 by the American Association for Laboratory Accreditation (A2LA) under the American Association for Laboratory Accreditation Program (A2LA Cert. No. 3628.01) in EMC, Telecommunications and Radio testing for FCC, Industry Canada, EU and TELEC Rules.



1. INTRODUCTION

1.1. Scope

Measurement and determination of electromagnetic emissions (EMC) of radio frequency devices including intentional and/or unintentional radiators for compliance with the technical rules and regulations of the Federal Communications Commission and the Industry Canada Certification and Engineering Bureau.

1.2. MRT Test Location

The map below shows the location of the MRT LABORATORY, its proximity to the Taihu Lake. These measurement tests were conducted at the MRT Technology (Suzhou) Co., Ltd. Facility located at D8 Building, No.2 Tian'edang Rd., Wuzhong Economic Development Zone, Suzhou, China. The detailed description of the measurement facility was found to be in compliance with the requirements of § 2.948 according to ANSI C63.4-2009 on September 30, 2013.



2. PRODUCT INFORMATION

2.1. Equipment Description

Product Name	IP Multimedia Phone
Model No.	GXV3275
Brand Name	Grandstream
WLAN Specification	802.11b/g/n
BT Specification	v3.0
Antenna	Pipe Copper Antenna, 1T1R
Components	
Adapter #1	M/N: H18US1200150A Input: AC 100-240V ~ 50/60Hz, 0.8A max OUTPUT: 12Vdc, 1.5A
Adapter #2	M/N: F18W8-120150SPAUY Input: AC 100-240V ~ 50/60Hz, 0.6A OUTPUT: 12Vdc, 1.5A

2.2. Product Specification Subjective to this Standard

Product Specification Subjective to this Standard	
Transmitter / Receiver Frequency Range	2402~2480MHz
Number of Channels	79
Channel Spacing	1MHz
Type of Modulation	FHSS
Data Rate	1Mbps(GFSK), 2Mbps(Pi/4 DQPSK), 3Mbps (8DPSK)

Note: For other features of this EUT, test report will be issued separately.

The equipment under test (EUT) is the **IP Multimedia Phone FCC ID: YZZGXV3275**. The test data contained in this report pertains only to the emissions due to the EUT's Bluetooth transmitter.

- 15.247(g): In accordance with the Bluetooth Industry Standard, the system is designed to comply with all of the regulations in Section 15.247 when the transmitter is presented with a continuous data (or information) system.
- 15.247(h): In accordance with the Bluetooth Industry Standard, the system does not coordinate its channels selection/ hopping sequence with other frequency hopping systems for the express purpose of avoiding the simultaneous occupancy of individual hopping frequencies by multiple transmitters.
- 15.247(h): The EUT employs Adaptive Frequency Hopping (AFH) which identifies sources of interference namely devices operating in 802.11 WLAN and excludes them from the list of available channels. The process of re-mapping reduces the number of test channels from 79 channels to a minimum number of 20 channels.

2.3. Operation Frequency / Channel List

Channel	Frequency	Channel	Frequency	Channel	Frequency
00	2402 MHz	01	2403 MHz	02	2404 MHz
03	2405 MHz	04	2406 MHz	05	2407 MHz
06	2408 MHz	07	2409 MHz	08	2410 MHz
09	2411 MHz	10	2412 MHz	11	2413 MHz
12	2414 MHz	13	2415 MHz	14	2416 MHz
15	2417 MHz	16	2418 MHz	17	2419 MHz
18	2420 MHz	19	2421 MHz	20	2422 MHz
21	2423 MHz	22	2424 MHz	23	2425 MHz
24	2426 MHz	25	2427 MHz	26	2428 MHz
27	2429 MHz	28	2430 MHz	29	2431 MHz
30	2432 MHz	31	2433 MHz	32	2434 MHz
33	2435 MHz	34	2436 MHz	35	2437 MHz
36	2438 MHz	37	2439 MHz	38	2440 MHz
39	2441 MHz	40	2442 MHz	41	2443 MHz
42	2444 MHz	43	2445 MHz	44	2446 MHz
45	2447 MHz	46	2448 MHz	47	2449 MHz
48	2450 MHz	49	2451 MHz	50	2452 MHz
51	2453 MHz	52	2454 MHz	53	2455 MHz
54	2456 MHz	55	2457 MHz	56	2458 MHz
57	2459 MHz	58	2460 MHz	59	2461 MHz
60	2462 MHz	61	2463 MHz	62	2464 MHz
63	2465 MHz	64	2466 MHz	65	2467 MHz
66	2468 MHz	67	2469 MHz	68	2470 MHz
69	2471 MHz	70	2472 MHz	71	2473 MHz
72	2474 MHz	73	2475 MHz	74	2476 MHz
75	2477 MHz	76	2478 MHz	77	2479 MHz
78	2480 MHz	N/A	N/A	N/A	N/A

2.4. Pseudorandom Frequency Hopping Sequence

The pseudorandom sequence may be generated in a nine-stage shift register whose 5th and 9th stage outputs are added in a modulo-two addition stage. And the result is fed back to the input of the first stage. The sequence begins with the first ONE of 9 consecutive ONES; i.e. the shift register is initialized with nine ones.

- Number of shift register stages: 9
- Length of pseudo-random sequence: $2^9 - 1 = 511$ bits
- Longest sequence of zeros: 8 (non-inverted signal)

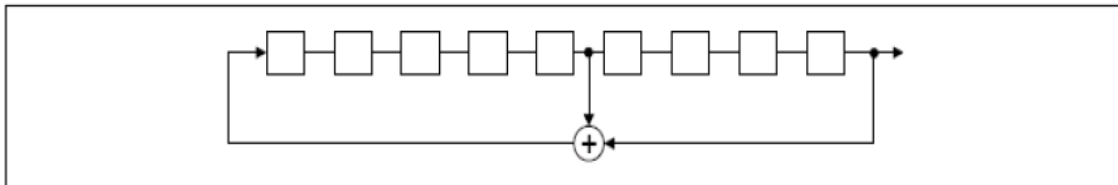

Linear Feedback Shift Register for Generation of the PRBS sequence

An example of Pseudorandom Frequency Hopping Sequence as follow:

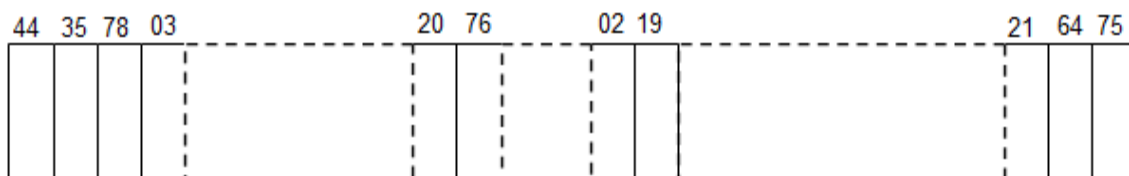

Each frequency used equally on the average by each transmitter.

The system receivers have input bandwidths that match the hopping channel bandwidths of their Corresponding transmitters and shift frequencies in synchronization with the transmitted signals.

2.5. Test Configuration

The **IP Multimedia Phone FCC ID: YZZGXV3275** was tested per the guidance of ANSI C63.10-2013 and DA 00-705. ANSI C63.10-2013 was used to reference the appropriate EUT setup for radiated spurious emissions testing and AC line conducted testing.

2.6. Test Software

The test utility software used during testing was engineering directive order by applicant.

2.7. EMI Suppression Device(s)/Modifications

No EMI suppression device(s) were added and/or no modifications were made during testing.

3. DESCRIPTION of TEST

3.1. Evaluation Procedure

The measurement procedures described in the American National Standard for Testing Unlicensed Wireless Devices (ANSI C63.10-2013), and the “Filing and Measurement Guidelines for Frequency Hopping Spread Spectrum Systems” (DA 00-705) were used in the measurement of the **IP Multimedia Phone FCC ID: YZZGXV3275**.

Deviation from measurement procedure.....None

3.2. AC Line Conducted Emissions

The line-conducted facility is located inside an 8'x4'x4' shielded enclosure. A 1m x 2m wooden table 80cm high is placed 40cm away from the vertical wall and 80cm away from the sidewall of the shielded room. Two 10kHz-30MHz, 50Ω/50uH Line-Impedance Stabilization Networks (LISNs) are bonded to the shielded room floor. Power to the LISNs is filtered by external high-current high-insertion loss power line filters. These filters attenuate ambient signal noise from entering the measurement lines. These filters are also bonded to the shielded enclosure.

The EUT is powered from one LISN and the support equipment is powered from the second LISN. All interconnecting cables more than 1 meter were shortened to a 1 meter length by non-inductive bundling (serpentine fashion) and draped over the back edge of the test table. All cables were at least 40cm above the horizontal reference ground-plane. Power cables for support equipment were routed down to the second LISN while ensuring that that cables were not draped over the second LISN.

Sufficient time for the EUT, support equipment, and test equipment was allowed in order for them to warm up to their normal operating condition. The RF output of the LISN was connected to the receiver and exploratory measurements were made to determine the frequencies producing the maximum emission from the EUT. The receiver was scanned from 150kHz to 30MHz. The detector function was set to peak mode for exploratory measurements while the bandwidth of the analyzer was set to 9kHz. The EUT, support equipment, and interconnecting cables were arranged and manipulated to maximize each emission. Each emission was also maximized by varying: power lines, the mode of operation or data exchange speed, or support equipment whichever determined the worst-case emission. Once the worst case emissions have been identified, the one EUT cable configuration/arrangement and mode of operation that produced these emissions were used for final measurements on the same test site. The analyzer is set to CISPR quasi-peak and average detectors with a 9kHz resolution bandwidth for final measurements.

An extension cord was used to connect to a single LISN which powered by EUT. The extension cord was calibrated with LISN, the impedance and insertion loss are compliance with the requirements as stated in ANSI C63.10-2013.

Line conducted emissions test results are shown in Section 6.3.

3.3. Radiated Emissions

The radiated test facilities consisted of an indoor 3 meter semi-anechoic chamber used for final measurements and exploratory measurements, when necessary. The measurement area is contained within the semi-anechoic chamber which is shielded from any ambient interference. For measurements above 1GHz absorbers are arranged on the floor between the turn table and the antenna mast in such a way so as to maximize the reduction of reflections. For measurements below 1GHz, the absorbers are removed. An MF Model 210SS turntable is used for radiated measurement. It is a continuously rotatable, remote controlled, metallic turntable and 2 meters (6.56 ft.) in diameter. The turn table is flush with the raised floor of the chamber in order to maintain its function as a ground plane. An 80cm high PVC support structure is placed on top of the turntable.

For all measurements, the spectrum was scanned through all EUT azimuths and from 1 to 4 meter receive antenna height using a broadband antenna from 30MHz up to the upper frequency shown in 15.33(b)(1) depending on the highest frequency generated or used in the device or on which the device operates or tunes. For frequencies above 1GHz, linearly polarized double ridge horn antennas were used. For frequencies below 30MHz, a calibrated loop antenna was used. When exploratory measurements were necessary, they were performed at 1 meter test distance inside the semi-anechoic chamber using broadband antennas, broadband amplifiers, and spectrum analyzers to determine the frequencies and modes producing the maximum emissions. Sufficient time for the EUT, support equipment, and test equipment was allowed in order for them to warm up to their normal operating condition. The test set-up for frequencies below 1GHz was placed on top of the 0.8 meter high, 1 x 1.5 meter table; and test set-up for frequencies 1-40GHz was placed on top of the 1.5 meter high, 1 x 1.5 meter table. The EUT, support equipment, and interconnecting cables were arranged and manipulated to maximize each emission. Appropriate precaution was taken to ensure that all emissions from the EUT were maximized and investigated. The system configuration, clock speed, mode of operation or video resolution, if applicable, turntable azimuth, and receive antenna height was noted for each frequency found.

Final measurements were made in the semi-anechoic chamber using calibrated, linearly polarized broadband and horn antennas. The test setup was configured to the setup that produced the worst case emissions. The spectrum analyzer was set to investigate all frequencies required for testing to compare the highest radiated disturbances with respect to the specified limits. The turntable containing the EUT was rotated through 360 degrees and the height of the receive antenna was varied 1 to 4 meters and stopped at the azimuth and height producing the maximum emission. Each emission was maximized by changing the orientation of the EUT through three orthogonal planes and changing the polarity of the receive antenna, whichever produced the worst-case emissions. According to 3dB Beamwidth of horn antenna, the horn antenna should be always directed to the EUT when rising height.

4. TEST EQUIPMENT CALIBRATION DATE

Conducted Emissions - SR2

Instrument	Manufacturer	Type No.	Asset No.	Cali. Interval	Cali. Due Date
EMI Test Receiver	R&S	ESR7	MRTSUE06001	1 year	2016/11/03
Two-Line V-Network	R&S	ENV216	MRTSUE06002	1 year	2016/11/03
Two-Line V-Network	R&S	ENV216	MRTSUE06003	1 year	2016/11/03
Temperature/ Meter Humidity	Yuhuaze	N/A	MRTSUE06180	1 year	2016/12/20

Radiated Emissions - AC2

Instrument	Manufacturer	Type No.	Asset No.	Cali. Interval	Cali. Due Date
Spectrum Analyzer	Agilent	N9010A	MRTSUE06124	1 year	2016/06/23
EMI Test Receiver	R&S	ESR7	MRTSUE06001	1 year	2016/11/03
TRILOG Antenna	Schwarzbeck	VULB9168	MRTSUE06172	1 year	2016/12/10
Temperature/ Meter Humidity	Mingao	ETH529	MRTSUE06170	1 year	2016/11/29

Software	Version	Function
e3	V 8.3.5	EMI Test Software

5. MEASUREMENT UNCERTAINTY

Where relevant, the following test uncertainty levels have been estimated for tests performed on the EUT as specified in CISPR 16-4-2. This uncertainty represents an expanded uncertainty expressed at approximately the 95% confidence level using a coverage factor of $k = 2$.

AC Conducted Emission Measurement
Measuring Uncertainty for a Level of Confidence of 95% ($U=2Uc(y)$): 150kHz~30MHz: 3.46dB
Radiated Emission Measurement
Measuring Uncertainty for a Level of Confidence of 95% ($U=2Uc(y)$): 9kHz ~ 1GHz: 4.18dB

6. TEST RESULT

6.1. Summary

Product Name: IP Multimedia Phone
FCC ID: YZZGXV3275
Method/System: Frequency Hopping Spread Spectrum (FHSS)
Number of Channels: 79

FCC Part Section(s)	Test Description	Test Limit	Test Condition	Test Result	Reference
15.209	General Field Strength Limits (Radiated Emission Limits)	Emissions in restricted bands must meet the radiated limits detailed in 15.209	Radiated	PASS	Section 6.2
15.207	AC Conducted Emissions 150kHz - 30MHz	< FCC 15.207 limits	Line Conducted	Pass	Section 6.3

Notes: All modes of operation and data rates were investigated. For radiated emission test, every axis (X, Y, Z) was also verified. The test results shown in the following sections represent the worst case emissions.

6.2. Radiated Spurious Emission Measurement

6.2.1. Test Limit

All out of band emissions appearing in a restricted band as specified in Section 15.205 of the Title 47 CFR must not exceed the limits shown in Table per Section 15.209.

FCC Part 15 Subpart C Paragraph 15.209		
Frequency [MHz]	Field Strength [V/m]	Measured Distance [Meters]
0.009 - 0.490	2400/F (kHz)	300
0.490 - 1.705	24000/F (kHz)	30
1.705 – 30	30	30
30 – 88	100	3
88 – 216	150	3
216 – 960	200	3
Above 960	500	3

6.2.2. Test Procedure Used

ANSI C63.10-2013 - Section 11.12.1

6.2.3. Test Setting

Peak Field Strength Measurements

1. Analyzer center frequency was set to the frequency of the radiated spurious emission of interest
2. RBW = as specified in Table 1
3. VBW = 3 * RBW
4. Detector = peak
5. Sweep time = auto couple
6. Trace mode = max hold
7. Trace was allowed to stabilize

Table 1 - RBW as a function of frequency

Frequency	RBW
9 ~ 150 kHz	200 ~ 300 Hz
0.15 ~ 30 MHz	9 ~ 10 kHz
30 ~ 1000 MHz	100 ~ 120 kHz
> 1000 MHz	1 MHz

6.2.4. Test Setup

30MHz ~ 1GHz Test Setup:

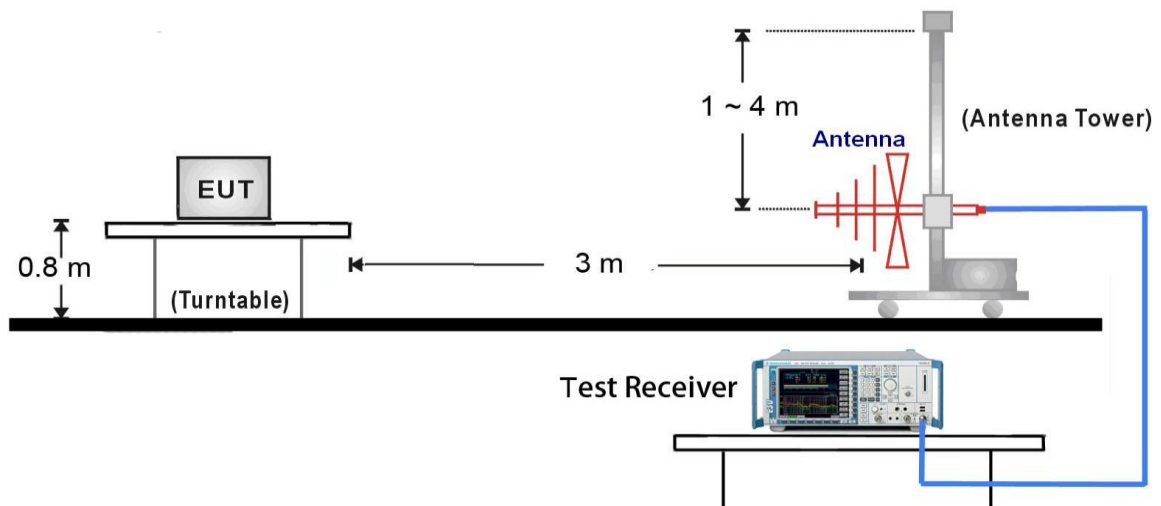

6.2.5. Test Result

The worst case of Radiated Emission 30MHz ~ 1GHz:

Site: AC2	Time: 2016/01/20 - 14:44
Limit: FCC_Part15.209_RE(3m)_Class B	Engineer: Lewis Huang
Probe: VULB9162_0.03-8GHz	Polarity: Horizontal
EUT: IP Multimedia Phone	Power: AC 120V/60Hz
Worse Case Mode: Transmit at Channel 2480MHz by DH5 (Adapter #1)	

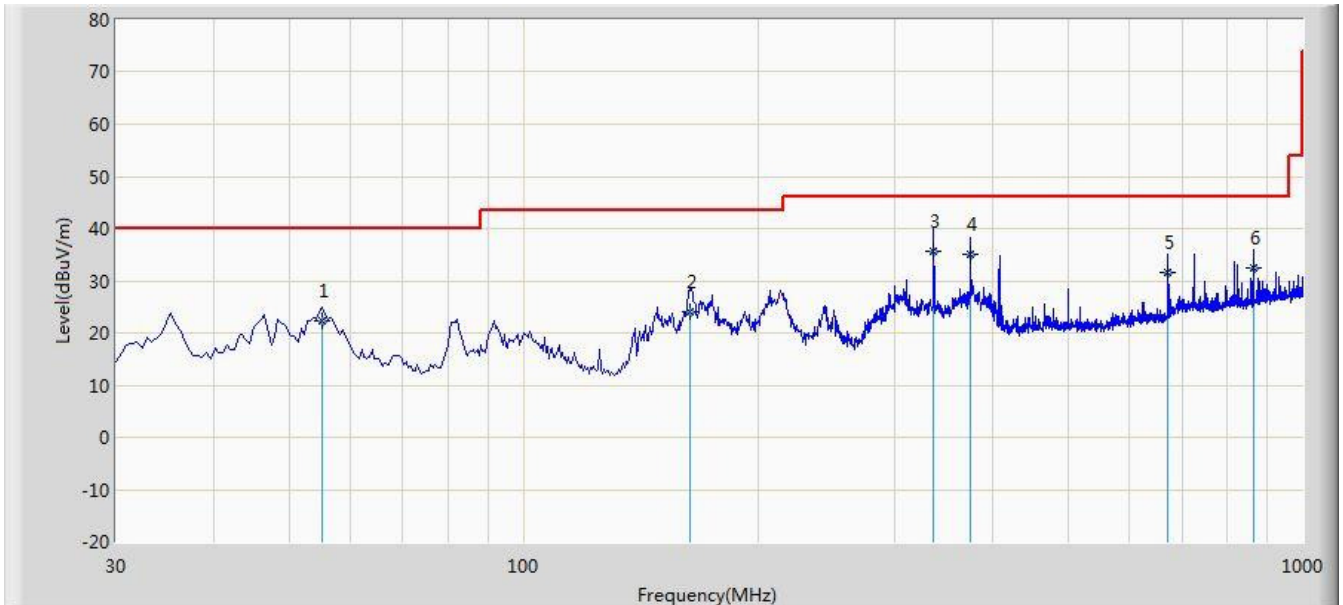

No	Flag	Mark	Frequency (MHz)	Measure Level (dBuV/m)	Reading Level (dBuV)	Over Limit (dB)	Limit (dBuV/m)	Factor (dB)	Type
1			55.220	22.288	7.640	-17.712	40.000	14.648	QP
2			163.860	24.144	14.150	-19.356	43.500	9.994	QP
3		*	336.035	35.710	20.140	-10.290	46.000	15.570	QP
4			374.835	35.188	18.970	-10.812	46.000	16.218	QP
5			672.140	31.471	10.360	-14.529	46.000	21.111	QP
6			864.200	32.495	8.650	-13.505	46.000	23.845	QP

Note: Measure Level (dB μ V/m) = Reading Level (dB μ V) + Factor (dB)

Factor (dB) = Cable Loss (dB) + Antenna Factor (dB/m)

Site: AC2	Time: 2016/01/20 - 14:46
Limit: FCC_Part15.209_RE(3m)_Class B	Engineer: Lewis Huang
Probe: VULB9162_0.03-8GHz	Polarity: Vertical
EUT: IP Multimedia Phone	Power: AC 120V/60Hz
Worse Case Mode: Transmit at Channel 2480MHz by DH5 (Adapter #1)	

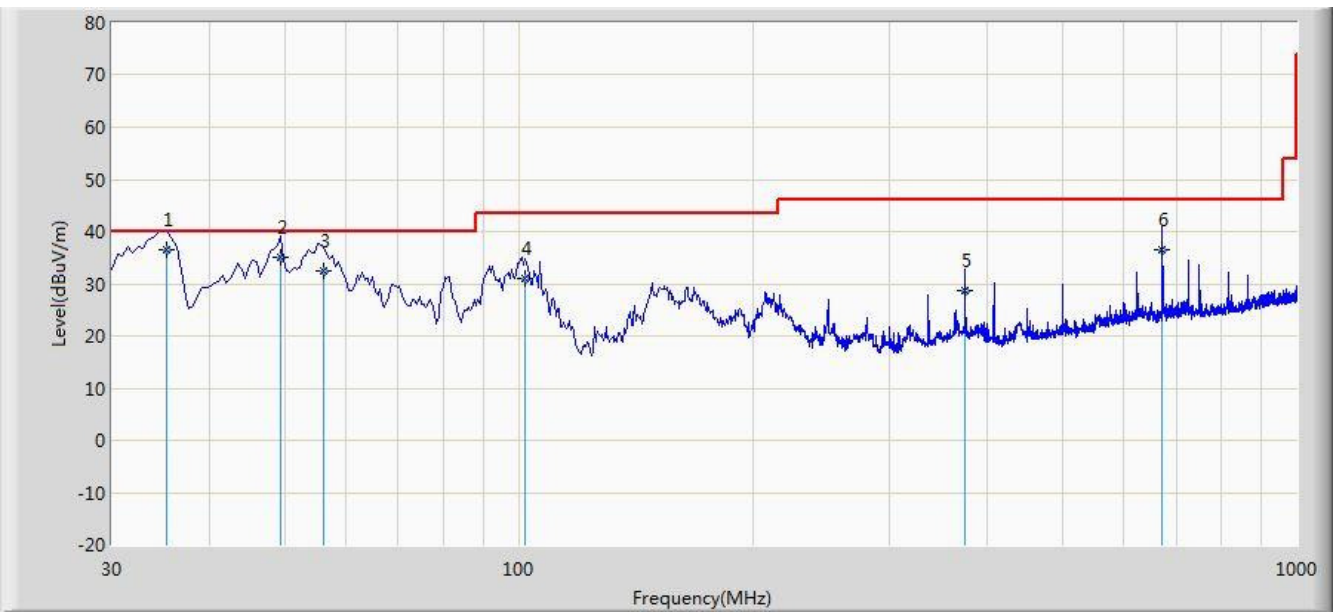

No	Flag	Mark	Frequency (MHz)	Measure Level (dBuV/m)	Reading Level (dBuV)	Over Limit (dB)	Limit (dBuV/m)	Factor (dB)	Type
1		*	35.335	36.652	23.650	-3.348	40.000	13.001	QP
2			49.400	35.103	20.140	-4.897	40.000	14.963	QP
3			56.190	32.439	17.960	-7.561	40.000	14.478	QP
4			101.780	31.154	17.950	-12.346	43.500	13.204	QP
5			374.835	28.688	12.470	-17.312	46.000	16.218	QP
6			672.140	36.471	15.360	-9.529	46.000	21.111	QP

Note: Measure Level (dB μ V/m) = Reading Level (dB μ V) + Factor (dB)

Factor (dB) = Cable Loss (dB) + Antenna Factor (dB/m)

Site: AC2	Time: 2016/01/20 - 14:58
Limit: FCC_Part15.209_RE(3m)_Class B	Engineer: Lewis Huang
Probe: VULB9162_0.03-8GHz	Polarity: Horizontal
EUT: IP Multimedia Phone	Power: AC 120V/60Hz
Worse Case Mode: Transmit at Channel 2480MHz by DH5 (Adapter #2)	

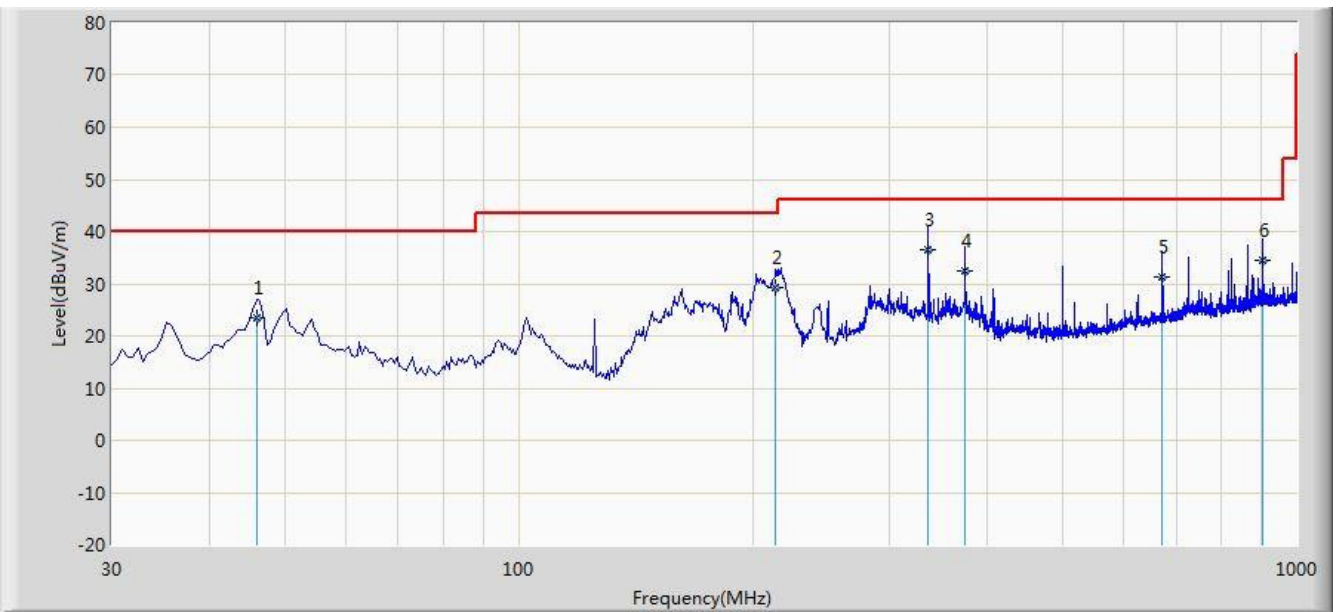

No	Flag	Mark	Frequency (MHz)	Measure Level (dBuV/m)	Reading Level (dBuV)	Over Limit (dB)	Limit (dBuV/m)	Factor (dB)	Type
1			46.005	23.366	8.360	-16.634	40.000	15.007	QP
2			213.815	29.159	16.650	-14.341	43.500	12.509	QP
3		*	336.035	36.580	21.010	-9.420	46.000	15.570	QP
4			374.835	32.568	16.350	-13.432	46.000	16.218	QP
5			672.140	31.431	10.320	-14.569	46.000	21.111	QP
6			904.455	34.416	10.240	-11.584	46.000	24.176	QP

Note: Measure Level (dB μ V/m) = Reading Level (dB μ V) + Factor (dB)

Factor (dB) = Cable Loss (dB) + Antenna Factor (dB/m)

Site: AC2	Time: 2016/01/20 - 15:01
Limit: FCC_Part15.209_RE(3m)_Class B	Engineer: Lewis Huang
Probe: VULB9162_0.03-8GHz	Polarity: Vertical
EUT: IP Multimedia Phone	Power: AC 120V/60Hz
Worse Case Mode: Transmit at Channel 2480MHz by DH5 (Adapter #2)	

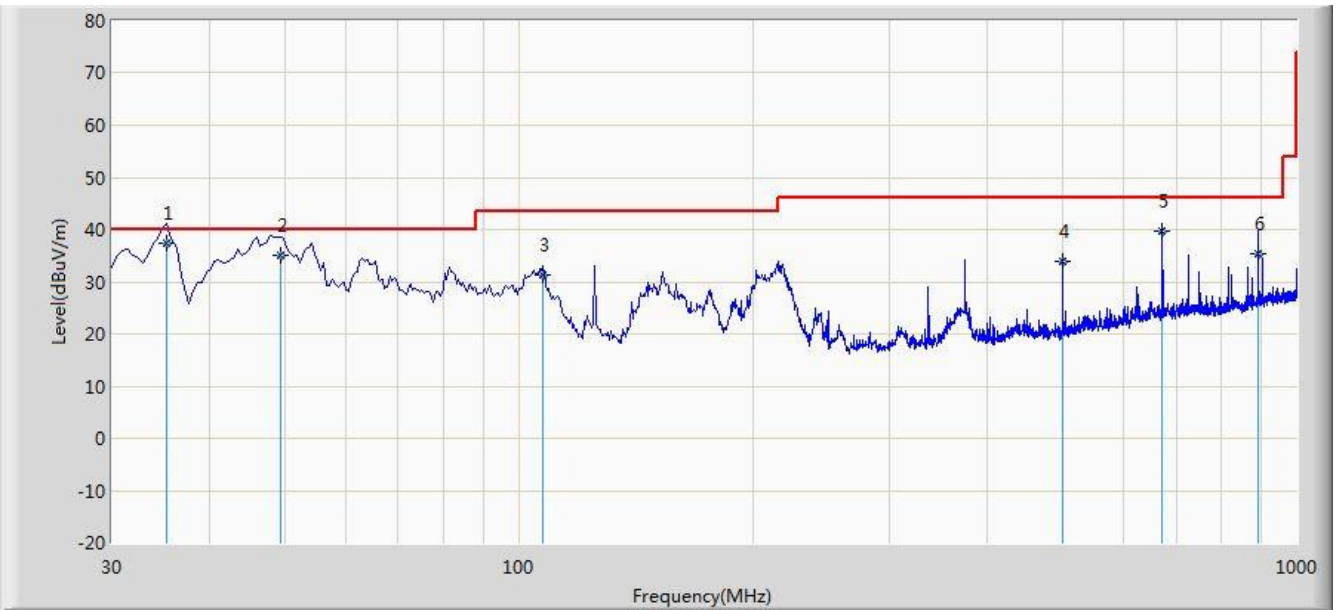

No	Flag	Mark	Frequency (MHz)	Measure Level (dBuV/m)	Reading Level (dBuV)	Over Limit (dB)	Limit (dBuV/m)	Factor (dB)	Type
1		*	35.335	37.362	24.360	-2.638	40.000	13.001	QP
2			49.400	35.103	20.140	-4.897	40.000	14.963	QP
3			107.600	31.378	18.350	-12.122	43.500	13.027	QP
4			499.965	34.011	15.680	-11.989	46.000	18.331	QP
5			672.140	39.751	18.640	-6.249	46.000	21.111	QP
6			892.815	35.325	11.240	-10.675	46.000	24.085	QP

Note: Measure Level (dB μ V/m) = Reading Level (dB μ V) + Factor (dB)

Factor (dB) = Cable Loss (dB) + Antenna Factor (dB/m)

6.3. AC Conducted Emissions Measurement

6.3.1. Test Limit

FCC Part 15 Subpart C Paragraph 15.207 Limits		
Frequency (MHz)	QP (dB μ V)	Average (dB μ V)
0.15 - 0.50	66 - 56	56 - 46
0.50 - 5.0	56	46
5.0 - 30	60	50

Note 1: The lower limit shall apply at the transition frequencies.

Note 2: The limit decreases linearly with the logarithm of the frequency in the range 0.15MHz to 0.5MHz.

6.3.2. Test Setup

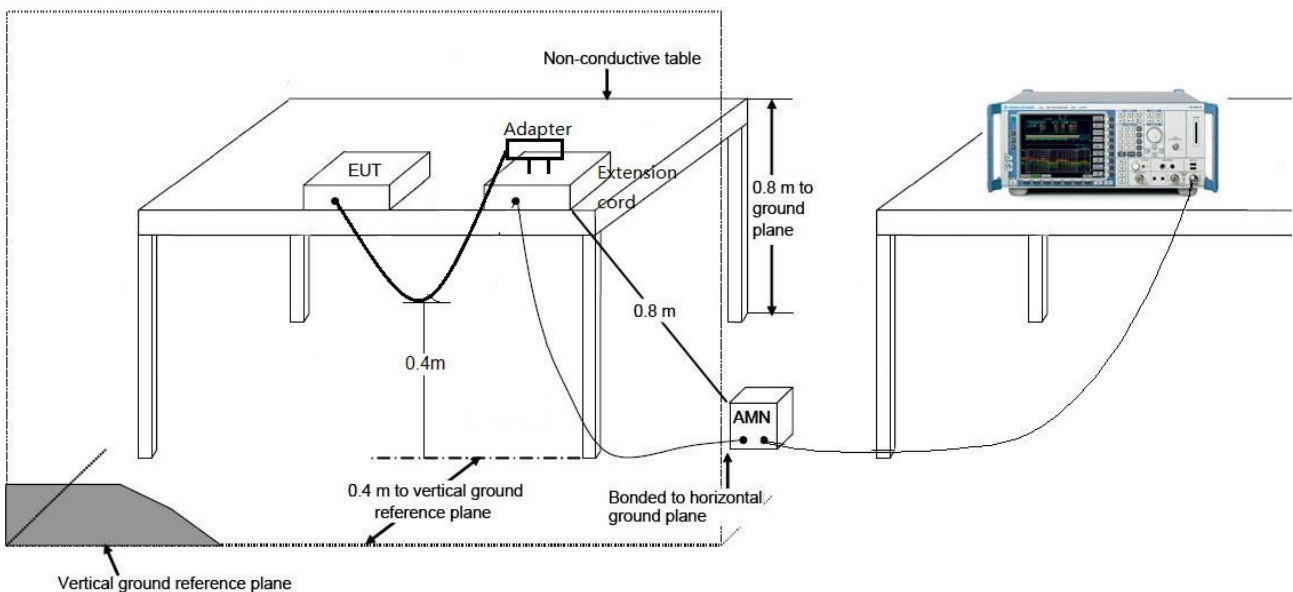

6.3.3. Test Result

Site: SR2	Time: 2016/01/12 - 17:12
Limit: FCC_Part15.207_CE_AC Power_Class B	Engineer: Vince Yu
Probe: ENV216_101683_Filter On	Polarity: Line
EUT: IP Multimedia Phone	Power: AC 120V/60Hz
Note: Transmit at Channel 2480MHz by DH5 (Adapter #1)	

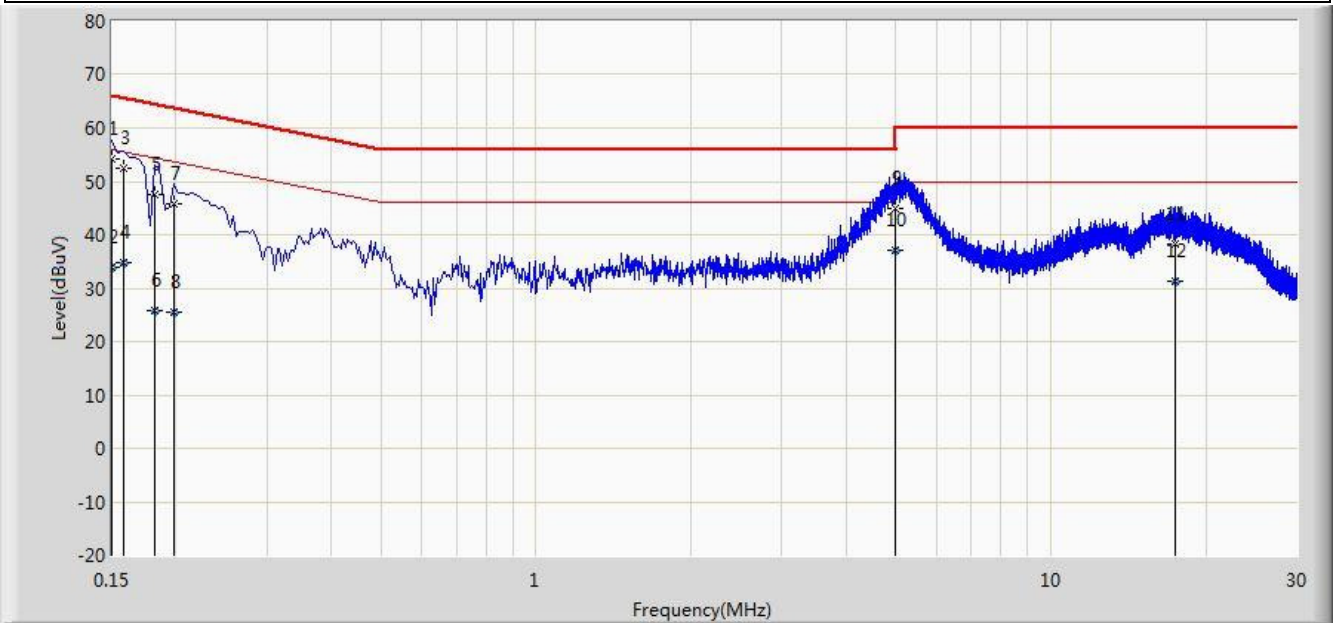

No	Flag	Mark	Frequency (MHz)	Measure Level (dBuV)	Reading Level (dBuV)	Over Limit (dB)	Limit (dBuV)	Factor (dB)	Type
1			0.150	54.066	42.898	-11.934	66.000	11.168	QP
2			0.150	33.917	22.748	-22.083	56.000	11.168	AV
3			0.158	52.452	42.141	-13.117	65.568	10.311	QP
4			0.158	34.772	24.461	-20.797	55.568	10.311	AV
5			0.182	47.541	37.493	-16.853	64.394	10.048	QP
6			0.182	25.723	15.675	-28.671	54.394	10.048	AV
7			0.198	45.664	35.659	-18.030	63.694	10.005	QP
8			0.198	25.518	15.513	-28.176	53.694	10.005	AV
9			4.998	44.793	34.764	-11.207	56.000	10.029	QP
10		*	4.998	37.157	27.128	-8.843	46.000	10.029	AV
11			17.386	38.319	28.230	-21.681	60.000	10.090	QP
12			17.386	31.331	21.241	-18.669	50.000	10.090	AV

Note: Measure Level (dBμV) = Reading Level (dBμV) + Factor (dB)

Factor (dB) = Cable Loss (dB) + LISN Factor (dB).

Site: SR2	Time: 2016/01/12 - 17:16
Limit: FCC_Part15.207_CE_AC Power_Class B	Engineer: Vince Yu
Probe: ENV216_101683_Filter On	Polarity: Neutral
EUT: IP Multimedia Phone	Power: AC 120V/60Hz
Note: Transmit at Channel 2480MHz by DH5 (Adapter #1)	

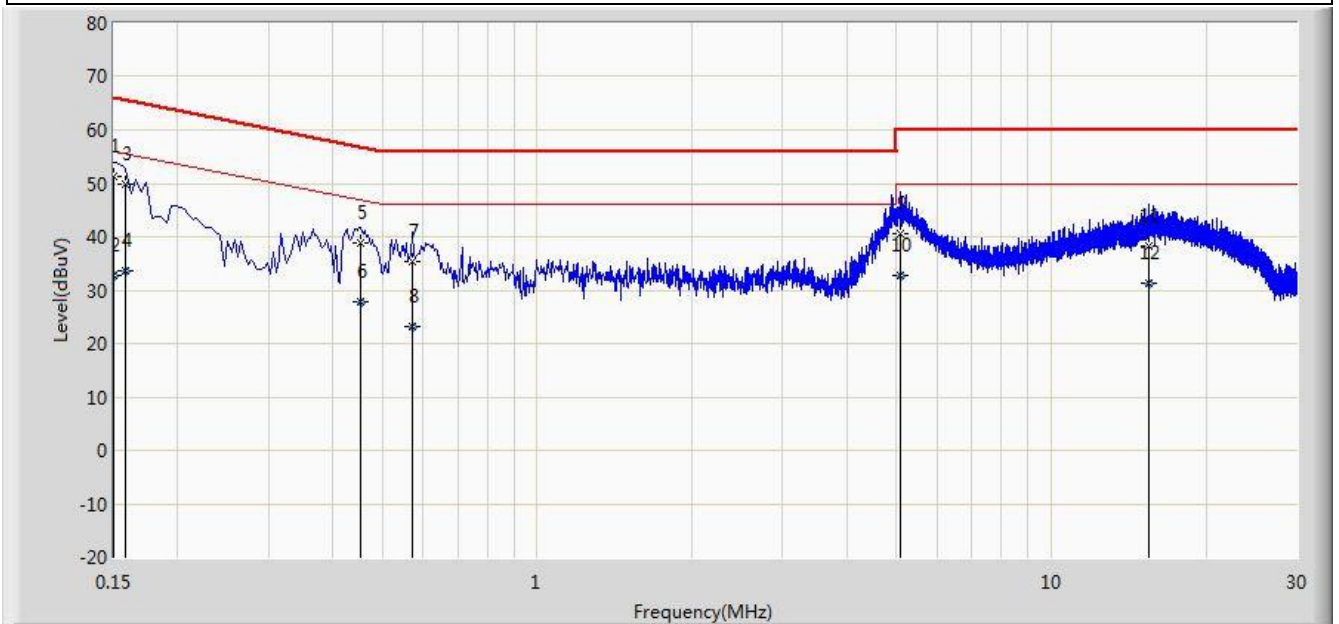

No	Flag	Mark	Frequency (MHz)	Measure Level (dBuV)	Reading Level (dBuV)	Over Limit (dB)	Limit (dBuV)	Factor (dB)	Type
1		*	0.150	51.419	40.277	-14.581	66.000	11.142	QP
2			0.150	32.772	21.630	-23.228	56.000	11.142	AV
3			0.158	49.971	39.681	-15.597	65.568	10.290	QP
4			0.158	33.502	23.212	-22.066	55.568	10.290	AV
5			0.454	38.924	28.771	-17.878	56.802	10.153	QP
6			0.454	27.803	17.650	-18.999	46.802	10.153	AV
7			0.570	35.475	25.328	-20.525	56.000	10.148	QP
8			0.570	23.075	12.928	-22.925	46.000	10.148	AV
9			5.082	40.591	30.537	-19.409	60.000	10.055	QP
10			5.082	32.858	22.803	-17.142	50.000	10.055	AV
11			15.454	38.356	28.236	-21.644	60.000	10.120	QP
12			15.454	31.421	21.301	-18.579	50.000	10.120	AV

Note: Measure Level (dBμV) = Reading Level (dBμV) + Factor (dB)

Factor (dB) = Cable Loss (dB) + LISN Factor (dB).

Site: SR2	Time: 2016/01/12 - 18:54
Limit: FCC_Part15.207_CE_AC Power_Class B	Engineer: Vince Yu
Probe: ENV216_101683_Filter On	Polarity: Line
EUT: IP Multimedia Phone	Power: AC 120V/60Hz
Note: Transmit at Channel 2480MHz by DH5 (Adapter #2)	

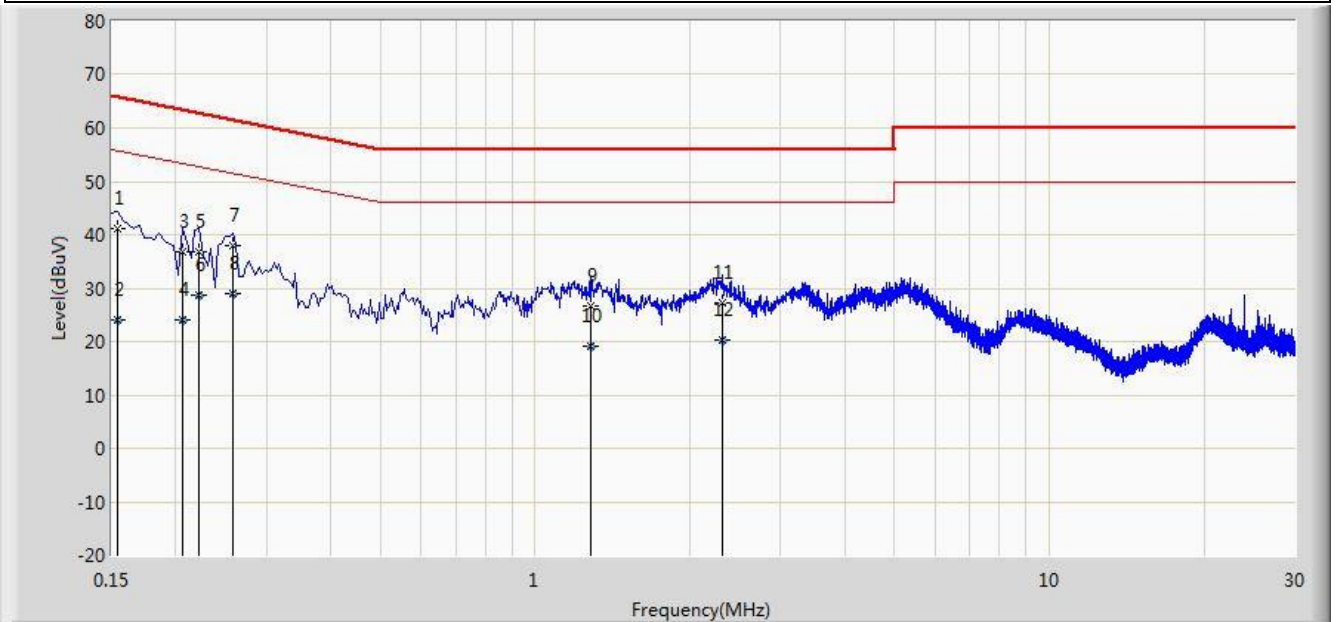

No	Flag	Mark	Frequency (MHz)	Measure Level (dBuV)	Reading Level (dBuV)	Over Limit (dB)	Limit (dBuV)	Factor (dB)	Type
1			0.154	41.129	30.389	-24.653	65.781	10.740	QP
2			0.154	24.182	13.443	-31.599	55.781	10.740	AV
3			0.206	36.736	26.755	-26.629	63.365	9.981	QP
4			0.206	24.116	14.135	-29.249	53.365	9.981	AV
5			0.222	36.694	26.753	-26.050	62.744	9.941	QP
6			0.222	28.838	18.898	-23.905	52.744	9.941	AV
7			0.258	37.896	27.926	-23.599	61.496	9.970	QP
8		*	0.258	29.001	19.031	-22.494	51.496	9.970	AV
9			1.282	26.791	16.892	-29.209	56.000	9.898	QP
10			1.282	19.107	9.209	-26.893	46.000	9.898	AV
11			2.306	27.192	17.329	-28.808	56.000	9.863	QP
12			2.306	20.203	10.340	-25.797	46.000	9.863	AV

Note: Measure Level (dBμV) = Reading Level (dBμV) + Factor (dB)

Factor (dB) = Cable Loss (dB) + LISN Factor (dB).

Site: SR2	Time: 2016/01/12 - 18:58
Limit: FCC_Part15.207_CE_AC Power_Class B	Engineer: Vince Yu
Probe: ENV216_101683_Filter On	Polarity: Neutral
EUT: IP Multimedia Phone	Power: AC 120V/60Hz
Note: Transmit at Channel 2480MHz by DH5 (Adapter #2)	

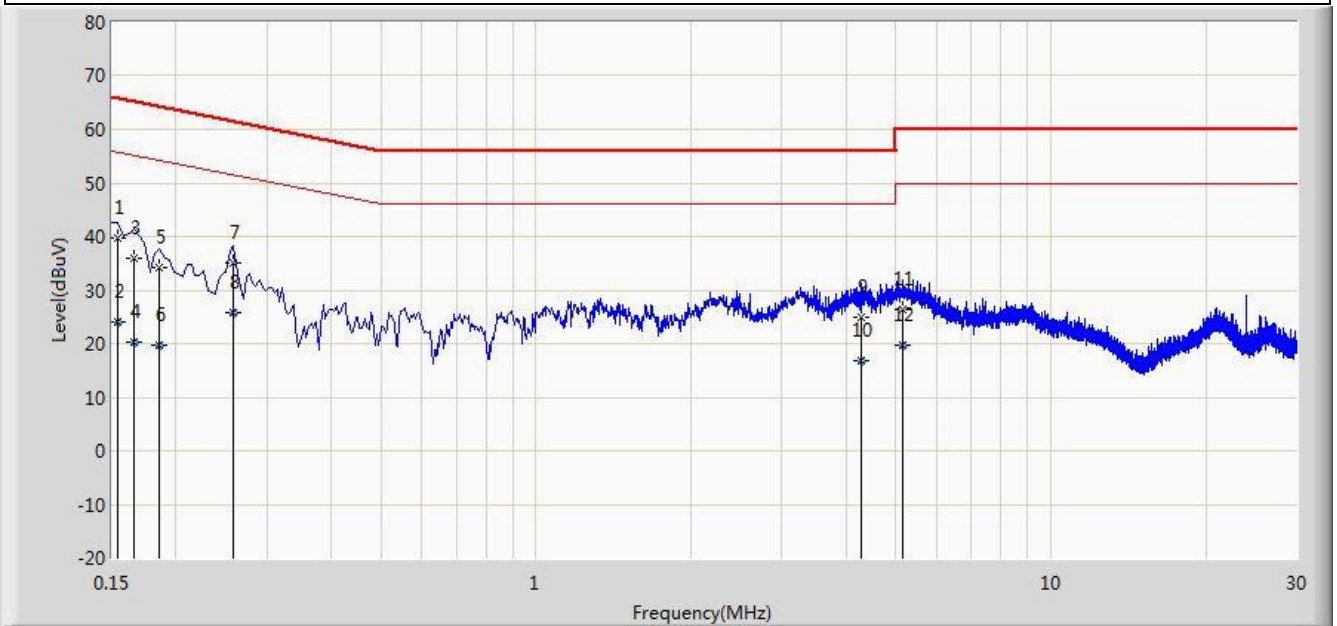

No	Flag	Mark	Frequency (MHz)	Measure Level (dBuV)	Reading Level (dBuV)	Over Limit (dB)	Limit (dBuV)	Factor (dB)	Type
1			0.154	39.585	28.869	-26.197	65.781	10.716	QP
2			0.154	23.947	13.231	-31.835	55.781	10.716	AV
3			0.166	36.013	25.942	-29.145	65.158	10.071	QP
4			0.166	20.196	10.125	-34.962	55.158	10.071	AV
5			0.186	34.100	24.065	-30.114	64.213	10.035	QP
6			0.186	19.740	9.705	-34.474	54.213	10.035	AV
7			0.258	35.164	25.157	-26.331	61.496	10.007	QP
8		*	0.258	25.698	15.692	-25.797	51.496	10.007	AV
9			4.294	24.960	14.973	-31.040	56.000	9.987	QP
10			4.294	16.835	6.848	-29.165	46.000	9.987	AV
11			5.154	26.479	16.421	-33.521	60.000	10.057	QP
12			5.154	19.784	9.726	-30.216	50.000	10.057	AV

Note: Measure Level (dBμV) = Reading Level (dBμV) + Factor (dB)

Factor (dB) = Cable Loss (dB) + LISN Factor (dB).

7. CONCLUSION

The data collected relate only the item(s) tested and show that the **IP Multimedia Phone FCC ID: YZZGXV3275** is in compliance with Part 15C of the FCC Rules.

————— The End —————