



Certificate #4312.01

DFS TEST REPORT

Product Name: High-Performance AX6000 Wi-Fi 6 Access Point
Trade Mark: GRANDSTREAM
Model No.: GWN7664E
Report Number: 2401259035RFC-3
Test Standards: FCC 47 CFR Part 15 Subpart E
FCC ID: YZZGWN7664E
Test Result: PASS
Date of Issue: May 28, 2024

Prepared for:

Grandstream Networks, Inc.
126 Brookline Ave., 3rd Floor Boston, MA 02215, USA

Prepared by:

Shenzhen UnionTrust Quality and Technology Co., Ltd.
Unit D/E of 9/F and 16/F, Block A, Building 6, Baoneng science and technology park, Longhua district, Shenzhen, China
TEL: +86-755-2823 0888
FAX: +86-755-2823 0886

Prepared by:

David Chen

 David Chen
 Senior Project Engineer

Reviewed by:

Robben chen

 Robben Chen
 Assistant Manager

Approved by:

Billy Li

 Billy Li
 Technical Director

Date:

May 28, 2024

Shenzhen UnionTrust Quality and Technology Co., Ltd.

Version

Version No.	Date	Description
V1.0	May 28, 2024	Original



Shenzhen UnionTrust Quality and Technology Co., Ltd.

Address: Unit D/E of 9/F and 16/F, Block A, Building 6, Baoneng science and technology park, Longhua district, Shenzhen, China

Tel: +86-755-28230888

Fax: +86-755-28230886

E-mail: info@uttlab.com

<http://www.uttlab.com>

UTTR-RF-FCCPART15.407-V1.3

CONTENTS

1. GENERAL INFORMATION	5
1.1 CLIENT INFORMATION	5
1.2 EUT INFORMATION	5
1.2.1 GENERAL DESCRIPTION OF EUT	5
1.2.2 DESCRIPTION OF ACCESSORIES.....	5
1.3 PRODUCT SPECIFICATION SUBJECTIVE TO THIS STANDARD	5
1.4 DESCRIPTION OF SUPPORT UNITS	6
1.5 TEST LOCATION	7
1.6 TEST FACILITY	7
1.7 DEVIATION FROM STANDARDS	7
1.8 ABNORMALITIES FROM STANDARD CONDITIONS	7
1.9 OTHER INFORMATION REQUESTED BY THE CUSTOMER	7
2. TEST SUMMARY	8
3. EQUIPMENT LIST	9
4. ENVIRONMENTAL CONDITIONS FOR TESTING	9
5. REQUIREMENTS AND PARAMETERS FOR DFS TEST	9
5.1 REFERENCE DOCUMENTS FOR TESTING	9
5.2 APPLICABILITY OF DFS REQUIREMENTS	10
5.3 DFS DETECTION THRESHOLDS	11
5.4 DFS RESPONSE REQUIREMENT VALUES	11
5.5 SHORT PULSE RADAR TEST WAVEFORMS	12
5.6 LONG PULSE RADAR TEST WAVEFORM	13
5.7 FREQUENCY HOPPING RADAR TEST WAVEFORM	15
6. CALIBRATION SETUP AND DFS TEST RESULTS	16
6.1 CALIBRATION OF RADAR WAVEFORM	16
6.1.1 RADAR WAVEFORM CALIBRATION PROCEDURE.....	16
6.1.2 CONDUCTED CALIBRATION SETUP	16
6.1.3 CALIBRATION DEVIATION	16
6.1.4 RADAR WAVEFORM CALIBRATION RESULT	17
6.2 U-NII DETECTION BANDWIDTH (7.8.1)	23
6.2.1 LIMIT OF U-NII DETECTION BANDWIDTH	23
6.2.2 TEST PROCEDURES	23
6.2.3 TEST SETUP	23
6.2.4 TEST DEVIATION	23
6.2.5 RESULT OF U-NII DETECTION BANDWIDTH	24
6.3 CHANNEL AVAILABILITY CHECK (7.8.2)	30
6.3.1 LIMIT OF CHANNEL AVAILABILITY CHECK	30
6.3.2 TEST PROCEDURES	30
6.3.3 TEST SETUP	32
6.3.4 TEST DEVIATION	32
6.3.5 RESULT OF CHANNEL AVAILABILITY CHECK TIME	33
6.4 IN-SERVICE MONITORING: CHANNEL MOVE TIME, CHANNEL CLOSING TRANSMISSION TIME AND NON-OCCUPANCY PERIOD (7.8.3)	35
6.4.1 LIMIT OF IN-SERVICE MONITORING.....	35
6.4.2 TEST PROCEDURES	35
6.4.3 TEST SETUP	36
6.4.4 TEST DEVIATION	36
6.4.5 RESULT OF CHANNEL MOVE TIME, CHANNEL CLOSING TRANSMISSION TIME AND NON-OCCUPANCY PERIOD FOR CLIENT BEACON TEST	36
6.4.6 CHANNEL MOVE TIME, CHANNEL CLOSING TRANSMISSION TIME AND NON-OCCUPANCY PERIOD TEST PLOTS	37
6.4.7 DATA TRAFFIC CHANNEL LOADING AND NOISE FLOOR PLOTS	39
6.5 STATISTICAL PERFORMANCE CHECK (7.8.4)	40

Shenzhen UnionTrust Quality and Technology Co., Ltd.

Address: Unit D/E of 9/F and 16/F, Block A, Building 6, Baoneng science and technology park, Longhua district, Shenzhen, China

Tel: +86-755-28230888

Fax: +86-755-28230886

E-mail: info@uttlab.com

<http://www.uttlab.com>

UTTR-RF-FCCPART15.407-V1.3

6.5.1 LIMIT OF STATISTICAL PERFORMANCE CHECK.....40
6.5.2 TEST PROCEDURES41
6.5.3 TEST SETUP42
6.5.4 TEST DEVIATION42
6.5.5 RESULT OF STATISTICAL PERFORMANCE CHECK.....43
6.6 BRIDGE AND/OR MESH MODE.....51
6.6.1 LIMIT OF BRIDGE AND/OR MESH MODE.....51
6.6.2 TEST RESULT51
7. RADAR PARAMETERS.....53
APPENDIX 1 PHOTOS OF TEST SETUP53
APPENDIX 2 PHOTOS OF EUT CONSTRUCTIONAL DETAILS.....53

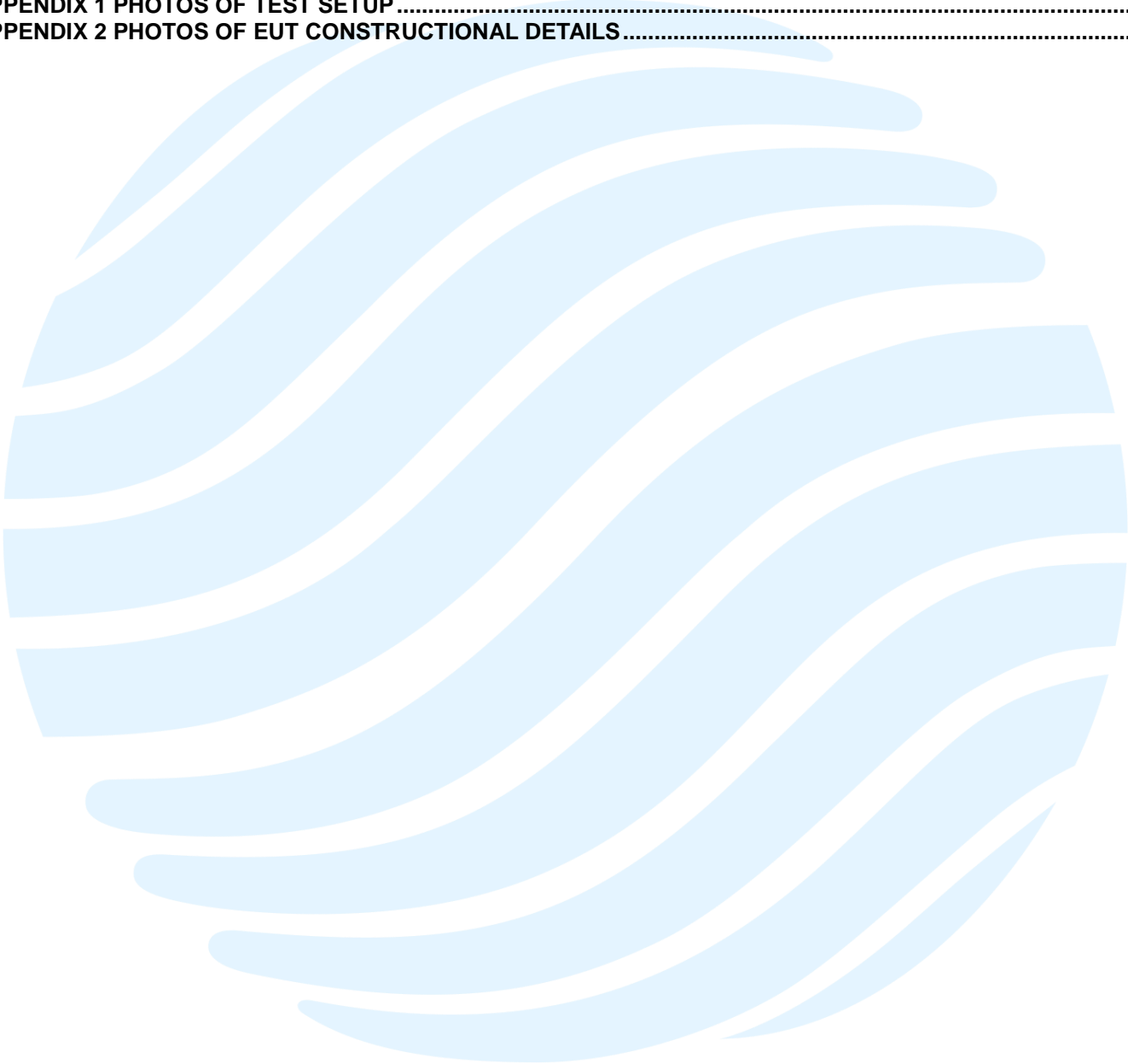

1. GENERAL INFORMATION

1.1 CLIENT INFORMATION

Applicant:	Grandstream Networks, Inc.
Address of Applicant:	126 Brookline Ave., 3rd Floor Boston, MA 02215, USA
Manufacturer:	Grandstream Networks, Inc.
Address of Manufacturer:	126 Brookline Ave., 3rd Floor Boston, MA 02215, USA

1.2 EUT INFORMATION

1.2.1 General Description of EUT

Product Name:	High-Performance AX6000 Wi-Fi 6 Access Point		
Model No.:	GWN7664E		
Trade Mark:	GRANDSTREAM		
DUT Stage:	Identical Prototype		
EUT Supports Function: (Provided by the customer)	2.4 GHz ISM Band:	IEEE 802.11b/g/n/ax	
	5 GHz U-NII Bands:	5 150 MHz to 5 250 MHz	IEEE 802.11a/n/ac/ax
		5 250 MHz to 5 350 MHz	IEEE 802.11a/n/ac/ax
		5 470 MHz to 5 725 MHz	IEEE 802.11a/n/ac/ax
		5 725 MHz to 5 850 MHz	IEEE 802.11a/n/ac/ax
5 850 MHz to 5 895 MHz	IEEE 802.11a/n/ac/ax		
Software Version:	0.1.23.1 (Provided by the customer)		
Hardware Version:	V1.0 (Provided by the customer)		
Sample Received Date:	January 25, 2024		
Sample Tested Date:	January 29, 2024 to May 16, 2024		

1.2.2 Description of Accessories

Others
1x Mounting Bracket, 1x Ceiling Mounting Bracket

1.3 PRODUCT SPECIFICATION SUBJECTIVE TO THIS STANDARD

Frequency Bands:	5150 MHz to 5250 MHz (U-NII-1)
	5250 MHz to 5350 MHz (U-NII-2A)
	5470 MHz to 5725 MHz (U-NII-2C)
	5725 MHz to 5850 MHz (U-NII-3)
	5850 MHz to 5895 MHz (U-NII-4)
Frequency Ranges:	5180 MHz to 5240 MHz
	5260 MHz to 5320 MHz
	5500 MHz to 5700 MHz
	5745 MHz to 5825 MHz
	5845 MHz to 5885 MHz
Support Standards:	IEEE 802.11a/n/ac/ax
TPC Function:	Support
Bridge Mode:	Support
Mesh Mode:	Support
DFS Operational mode:	Master
Type of Modulation:	IEEE 802.11a/n: OFDM (64QAM, 16QAM, QPSK, BPSK)

Shenzhen UnionTrust Quality and Technology Co., Ltd.

Address: Unit D/E of 9/F and 16/F, Block A, Building 6, Baoneng science and technology park, Longhua district, Shenzhen, China

Tel: +86-755-28230888

Fax: +86-755-28230886

E-mail: info@uttlab.com

<http://www.uttlab.com>

UTTR-RF-FCCPART15.407-V1.3

	IEEE 802.11ac: OFDM (256QAM, 64QAM, 16QAM, QPSK, BPSK)
	IEEE 802.11ax: OFDMA (1024QAM, 256QAM, 64QAM, 16QAM, QPSK, BPSK)
Channel Spacing:	IEEE 802.11a/n-HT20/ac-VHT20/ax-HE20: 20 MHz
	IEEE 802.11n-HT40/ac-VHT40/ax-HE40: 40 MHz
	IEEE 802.11ac-VHT80/ax-HE80: 80 MHz
	IEEE 802.11ac-VHT160/ax-HE160: 160 MHz
Data Rate:	IEEE 802.11a: Up to 54 Mbps
	IEEE 802.11n: Up to MCS31
	IEEE 802.11ac-VHT20: Up to MCS8
	IEEE 802.11ac-VHT40/VHT80/VHT160: Up to MCS9
	IEEE 802.11ax-HE20/HE40/HE80/HE160: Up to MCS11
Number of Channels:	5150 MHz to 5350 MHz: 8 for 802.11a/n-HT20/ac-VHT20/ax-HE20 4 for 802.11n-HT40/ac-VHT40/ax-HE40 2 for 802.11ac-VHT80/ax-HE80 1 for 802.11ac-VHT160/ax-HE160
	5470 MHz to 5725 MHz: 12 for 802.11a/n-HT20/ac-VHT20/ax-HE20 6 for 802.11n-HT40/ac-VHT40/ax-HE40 3 for 802.11ac-VHT80/ax-HE80 1 for 802.11ac-VHT160/ax-HE160
	5725 MHz to 5895 MHz: 8 for IEEE 802.11a/n-HT20/ac-VHT20/ax-HE20 4 for IEEE 802.11n-HT40/ac-VHT40/ax-HE40 2 for IEEE 802.11ac-VHT80/ax-HE80 1 for 802.11ac-VHT160/ax-HE160

1.4 DESCRIPTION OF SUPPORT UNITS

The EUT has been tested with associated equipment below.

1) Support Equipment

Description	Manufacturer	Model No.	Serial Number	Supplied by
POE	Gospower	G0720-480-050	N/A	Applicant
Key-Press Attenuator	Huaxin	KT2.5-90/1S-2S	N/A	UnionTrust
4 Way Divider	WOKEN	0120A040560002D	N/A	UnionTrust
Notebook	DELL	Latitude 3400	16238087894	UnionTrust
Mouse	DELL	MS111	CN-011D3V-738	UnionTrust
Enterprise Full Touch Handheld Computer	Bluebird Inc.	EF551	N/A	UnionTrust

2) Support Cable

Cable No.	Description	Connector	Length	Supplied by
1	Ethernet Cable	RJ45	1.5 Unshielded without ferrite	UnionTrust
2	Antenna Cable*2	SMA	0.1	UnionTrust

1.5 TEST LOCATION

Shenzhen UnionTrust Quality and Technology Co., Ltd.

Address: Unit D/E of 9/F and 16/F, Block A, Building 6, Baoneng science and technology park, Longhua district, Shenzhen, China 518109

Telephone: +86 (0) 755 2823 0888

Fax: +86 (0) 755 2823 0886

1.6 TEST FACILITY

The test facility is recognized, certified, or accredited by the following organizations:

CNAS-Lab Code: L9069

The measuring equipment utilized to perform the tests documented in this report has been calibrated once a year or in accordance with the manufacturer's recommendations, and is traceable under the ISO/IEC 17025 to international or national standards. Equipment has been calibrated by accredited calibration laboratories.

A2LA-Lab Certificate No.: 4312.01

Shenzhen UnionTrust Quality and Technology Co., Ltd. has been accredited by A2LA for technical competence in the field of electrical testing, and proved to be in compliance with ISO/IEC 17025 General Requirements for the Competence of Testing and Calibration Laboratories and any additional program requirements in the identified field of testing.

ISED Wireless Device Testing Laboratories

CAB identifier: CN0032

FCC Accredited Lab.

Designation Number: CN1194

Test Firm Registration Number: 259480

1.7 DEVIATION FROM STANDARDS

None.

1.8 ABNORMALITIES FROM STANDARD CONDITIONS

None.

1.9 OTHER INFORMATION REQUESTED BY THE CUSTOMER

None.

2. TEST SUMMARY

Test Requirement	Measured				Limit	Result
	5250 MHz to 5350 MHz (U-NII-2A)		5470 MHz to 5725 MHz (U-NII-2C)			
	20 MHz 5300 MHz	40 MHz 5310 MHz	20 MHz 5500 MHz	40 MHz 5510 MHz		
Channel Availability Check Time	> 60 sec	> 60 sec	> 60 sec	> 60 sec	> 60sec	PASS
U-NII Detection Bandwidth	20 MHz	38 MHz	20 MHz	38 MHz	> 100% of the U-NII 99% transmission power bandwidth	PASS
Channel Move Time	Note 1	Note 1	Note 1	Note 1	< 10 sec	PASS
Channel Closing Transmission Time	Note 1	Note 1	Note 1	Note 1	< 200 ms + aggregate of 60 ms over remaining 10 s period	PASS
Non-Occupancy Period Test	No transmission or Beacons occurred	No transmission or Beacons occurred	No transmission or Beacons occurred	No transmission or Beacons occurred	> 30 minutes	PASS

Note 1: only require test widest bandwidth

Test Requirement	Measured				Limit	Result
	5250 MHz to 5350 MHz (U-NII-2A)		5470 MHz to 5725 MHz (U-NII-2C)			
	80 MHz 5290 MHz	160 MHz 5250 MHz	80 MHz 5530 MHz	160 MHz 5570 MHz		
Channel Availability Check Time	> 60 sec	> 60 sec	> 60 sec	> 60 sec	> 60sec	PASS
U-NII Detection Bandwidth	78 MHz	156 MHz	78 MHz	156 MHz	> 100% of the U-NII 99% transmission power bandwidth	PASS
Channel Move Time	Note 1	1.488 s	Note1	1.453 s	< 10 sec	PASS
Channel Closing Transmission Time	Note 1	200ms + 5.4 ms	Note 1	200ms + 33.6 ms	< 200 ms + aggregate of 60 ms over remaining 10 s period	PASS
Non-Occupancy Period Test	No transmission or Beacons occurred	No transmission or Beacons occurred	No transmission or Beacons occurred	No transmission or Beacons occurred	> 30 minutes	PASS

Note 1: only require test widest bandwidth

3. EQUIPMENT LIST

Conducted RF test Equipment List						
Used	Equipment	Manufacturer	Model No.	Serial Number	Cal. date	Cal. Due date
<input checked="" type="checkbox"/>	EXA Spectrum Analyzer	KEYSIGHT	N9010A	MY51440197	14-Apr-2023 29-Mar-2024	13-Apr-2024 28-Mar-2025
<input checked="" type="checkbox"/>	MXG X-Series RF Vector Signal Generator	KEYSIGHT	N5182B	MY51350267	27-Oct-2023	26-Oct-2024
<input checked="" type="checkbox"/>	Spectrum Analyzer	R&S	FSV40-N	101653	14-Apr-2023 29-Mar-2024	13-Apr-2024 28-Mar-2025

4. ENVIRONMENTAL CONDITIONS FOR TESTING

Environment Parameter	Selected Values During Tests		
Test Condition	Ambient		
	Temperature (°C)	Voltage	Relative Humidity (%)
NT/NV	+15 to +35	48Vdc	20 to 75
Remark:			
1) NV: Normal Voltage; NT: Normal Temperature			

5. REQUIREMENTS AND PARAMETERS FOR DFS TEST

5.1 REFERENCE DOCUMENTS FOR TESTING

No.	Identity	Document Title
1	FCC 47 CFR Part 15	Radio Frequency Devices
2	KDB 905462 D06 802.11 Channel Plans New Rules v02	Operation in U-NII bands -802.11 channel PLAN(§15.407)
3	KDB 905462 D02 UNII DFS Compliance Procedures New Rules v02	Compliance measurement procedures for Unlicensed –National Information Infrastructure devices operates in the frequency bands 5250 MHz to 5350 MHz and 5470 MHz to 5725 MHz bands incorporating dynamic frequency selection
4	KDB 905462 D04 Test Mode New Rules v01	Operational modes suggested for DFS testing

5.2 APPLICABILITY OF DFS REQUIREMENTS

EUT Operating Mode:

DFS Operational mode	Operating Frequency Range	
	5250 MHz to 5350 MHz	5470 MHz to 5725 MHz
Master	✓	✓

Applicability:

The following table from KDB905462 and the lists of the applicable requirements for the DFS testing.

Table 1 – Applicability of DFS Requirements Prior to Use of a Channel:

Requirement	Operational Mode		
	Master	Client Without Radar Detection	Client With Radar Detection
Non-Occupancy Period	Yes	Not required	Yes
DFS Detection Threshold	Yes	Not required	Yes
Channel Availability Check Time	Yes	Not required	Not required
U-NII Detection Bandwidth	Yes	Not required	Yes

Table 2 – Applicability of DFS requirements during normal operation:

Requirement	Operational Mode		
	Master Device or	Client Without Radar Detection	Client with Radar Detection
DFS Detection Threshold	Yes	Not required	Yes
Channel Closing Transmission Time	Yes	Yes	Yes
Channel Move Time	Yes	Yes	Yes
U-NII Detection Bandwidth	Yes	Not required	Yes
Client Beacon Test	N/A	Yes	Yes
Additional requirements for devices with multiple bandwidth modes	Operational Mode		
	Master Device or Client with Radar Detection	Client Without Radar Detection	
U-NII Detection Bandwidth and Statistical Performance Check	All BW modes must be tested	Not required	
Channel Move Time and Channel Closing Transmission Time	Test using widest BW mode available	Test using the widest BW mode available for the link	
All other tests	Any single BW mode	Not required	
<p>Note: Frequencies selected for statistical performance check (Section 7.8.4) should include several frequencies within the radar detection bandwidth and frequencies near the edge of the radar detection bandwidth. For 802.11 devices it is suggested to select frequencies in each of the bonded 20 MHz channels and the channel center frequency.</p>			

5.3 DFS DETECTION THRESHOLDS

Table 3 – DFS Detection Thresholds for Master Devices and Client Devices with Radar Detection:

Maximum Transmit Power	Value (See Notes 1, 2, and 3)
EIRP ≥ 200 mw	-64 dBm
EIRP < 200 mw and power spectral density < 10 dBm/MHz	-62 dBm
EIRP < 200 mw that do not meet the power spectral density requirement	-64 dBm
<p>Note 1: This is the level at the input of the receiver assuming a 0 dBi receive antenna.</p> <p>Note 2: Throughout these test procedures an additional 1 dB has been added to the amplitude of the test transmission waveforms to account for variations in measurement equipment. This will ensure that the test signal is at or above the detection threshold level to trigger a DFS response.</p> <p>Note3: EIRP is based on the highest antenna gain. For MIMO devices refer to KDB Publication 662911 D01.</p>	

The radar Detection Threshold, lowest antenna gain is the parameter of Interference radar DFS detection threshold, The Interference Detection Threshold is -64 dBm

5.4 DFS RESPONSE REQUIREMENT VALUES

Table 4 – DFS Radar Signal Parameter Values:

Parameter	Value
Non-occupancy period	Minimum 30 minutes
Channel Availability Check Time	60 seconds
Channel Move Time	10 seconds (See Note 1.)
Channel Closing Transmission Time	200 milliseconds + an aggregate of 60 milliseconds over remaining 10 second period. (See Notes 1 and 2.)
U-NII Detection Bandwidth	Minimum 100% of the U-NII 99% transmission power bandwidth. (See Note 3.)
<p>Note 1: Channel Move Time and the Channel Closing Transmission Time should be performed with Radar Type 0. The measurement timing begins at the end of the Radar Type 0 burst.</p> <p>Note 2: The Channel Closing Transmission Time is comprised of 200 milliseconds starting at the beginning of the Channel Move Time plus any additional intermittent control signals required to facilitate a Channel move (an aggregate of 60 milliseconds) during the remainder of the 10 second period. The aggregate duration of control signals will not count quiet periods in between transmissions.</p> <p>Note 3: During the U-NII Detection Bandwidth detection test, radar type 0 should be used. For each frequency step the minimum percentage of detection is 90 percent. Measurements are performed with no data traffic.</p>	

5.5 SHORT PULSE RADAR TEST WAVEFORMS

DFS Radar Signal Parameter:

Radar Type 0 was used in the evaluation of the Client device for the purpose of measuring the Channel Move Time and the Channel Closing Transmission Time

Short Pulse Radar Test Waveforms

Radar Type	Pulse Width (μsec)	PRI (μsec)	Number of Pulses	Minimum Percentage of Successful Detection	Minimum Trials
0	1	1428	18	See Note 1.	See Note 1.
1	1	Test A Test B	Roundup $\left\{ \begin{matrix} \left(\frac{1}{360} \right) \\ \left(\frac{19 \cdot 10^6}{PRI_{\mu sec}} \right) \end{matrix} \right\}$	60%	30
2	1-5	150-230	23-29	60%	30
3	6-10	200-500	16-18	60%	30
4	11-20	200-500	12-16	60%	30
Aggregate (Radar Types 1-4)				80%	120
Note 1: Short Pulse Radar Type 0 should be used for the detection bandwidth test, channel move time, and channel closing time tests.					

Test A: 15 unique PRI values randomly selected from the list of 23 PRI values in Table 5a

Test B: 15 unique PRI values randomly selected within the range of 518-3066 μsec, with a minimum increment of 1 μsec, excluding PRI values selected in Test A

A minimum of 30 unique waveforms are required for each of the Short Pulse Radar Types 2 through 4. If more than 30 waveforms are used for Short Pulse Radar Types 2 through 4, then each additional waveform must also be unique and not repeated from the previous waveforms.

If more than 30 waveforms are used for Short Pulse Radar Type 1, then each additional waveform is generated with Test B and must also be unique and not repeated from the previous waveforms in Tests A or B.

The aggregate is the average of the percentage of successful detections of short pulse radar types 1-4

5.6 LONG PULSE RADAR TEST WAVEFORM

Long Pulse Radar Test Waveform

Radar Type	Pulse Width (µsec)	Chirp Width (MHz)	PRI (µsec)	Number of Pulses per Burst	Number of Bursts	Minimum Percentage of Successful Detection	Minimum Trials
5	50-100	5-20	1000-2000	1-3	8-20	80%	30

The parameters for this waveform are randomly chosen. Thirty unique waveforms are required for the Long Pulse radar test signal. If more than 30 waveforms are used for the Long Pulse radar test signal, then each additional waveform must also be unique and not repeated from the previous waveforms. Each waveform is defined as follows:

- (1) The transmission period for the Long Pulse Radar test signal is 12 seconds.
- (2) There are a total of 8 to 20 Bursts in the 12 second period, with the number of Bursts being randomly chosen. This number is Burst_Count.
- (3) Each Burst consists of 1 to 3 pulses, with the number of pulses being randomly chosen. Each Burst within the 12 second sequence may have a different number of pulses.
- (4) The pulse width is between 50 and 100 microseconds, with the pulse width being randomly chosen. Each pulse within a Burst will have the same pulse width. Pulses in different Bursts may have different pulse widths.
- (5) Each pulse has a linear FM chirp between 5 and 20 MHz, with the chirp width being randomly chosen. Each pulse within a Burst will have the same chirp width. Pulses in different Bursts may have different chirp widths. The chirp is centered on the pulse. For example, with a radar frequency of 5300 MHz and a 20 MHz chirped signal, the chirp starts at 5290 MHz and ends at 5310 MHz.
- (6) If more than one pulse is present in a Burst, the time between the pulses will be between 1000 and 2000 microseconds, with the time being randomly chosen. If three pulses are present in a Burst, the time between the first and second pulses is chosen independently of the time between the second and third pulses.
- (7) The 12 second transmission period is divided into even intervals. The number of intervals is equal to Burst_Count. Each interval is of length $(12,000,000 / \text{Burst_Count})$ microseconds. Each interval contains one Burst. The start time for the Burst, relative to the beginning of the interval, is between 1 and $[(12,000,000 / \text{Burst_Count}) - (\text{Total Burst Length}) + (\text{One Random PRI Interval})]$ microseconds, with the start time being randomly chosen. The step interval for the start time is 1 microsecond. The start time for each Burst is chosen independently.

A representative example of a Long Pulse radar test waveform:

- (1) The total test signal length is 12 seconds.
- (2) 8 Bursts are randomly generated for the Burst_Count.
- (3) Burst 1 has 2 randomly generated pulses.
- (4) The pulse width (for both pulses) is randomly selected to be 75 microseconds.
- (5) The PRI is randomly selected to be at 1213 microseconds.
- (6) Bursts 2 through 8 are generated using steps 3 – 5.
- (7) Each Burst is contained in even intervals of 1,500,000 microseconds. The starting location for Pulse 1, Burst 1 is randomly generated (1 to 1,500,000 minus the total Burst 1 length + 1 random PRI interval) at the 325,001 microsecond step. Bursts 2 through 8 randomly fall in successive 1,500,000 microsecond intervals (i.e. Burst 2 falls in the 1,500,001 – 3,000,000 microsecond range).

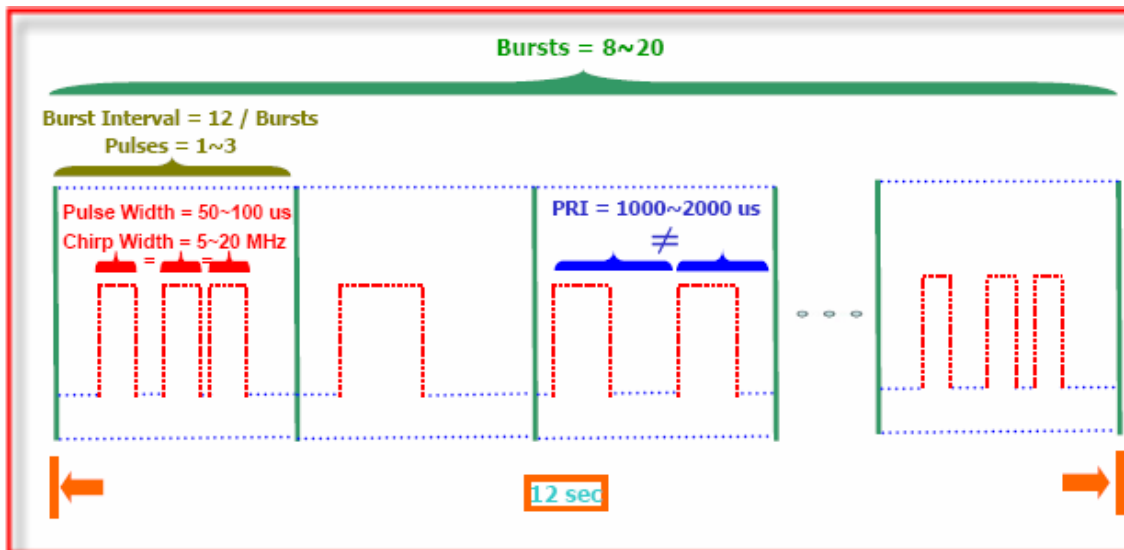

5.7 FREQUENCY HOPPING RADAR TEST WAVEFORM

Frequency Hopping Radar Test Waveform

Radar Type	Pulse Width (µsec)	PRI (µsec)	Pulses per Hop	Hopping Rate (kHz)	Hopping Sequence Length (msec)	Minimum Percentage of Successful Detection	Minimum Trials
6	1	333	9	0.333	300	70%	30

For the Frequency Hopping Radar Type, the same Burst parameters are used for each waveform. The hopping sequence is different for each waveform and a 100-length segment is selected from the hopping sequence defined by the following algorithm: The first frequency in a hopping sequence is selected randomly from the group of 475 integer frequencies from 5250 – 5724 MHz. Next, the frequency that was just chosen is removed from the group and a frequency is randomly selected from the remaining 474 frequencies in the group. This process continues until all 475 frequencies are chosen for the set. For selection of a random frequency, the frequencies remaining within the group are always treated as equally likely.

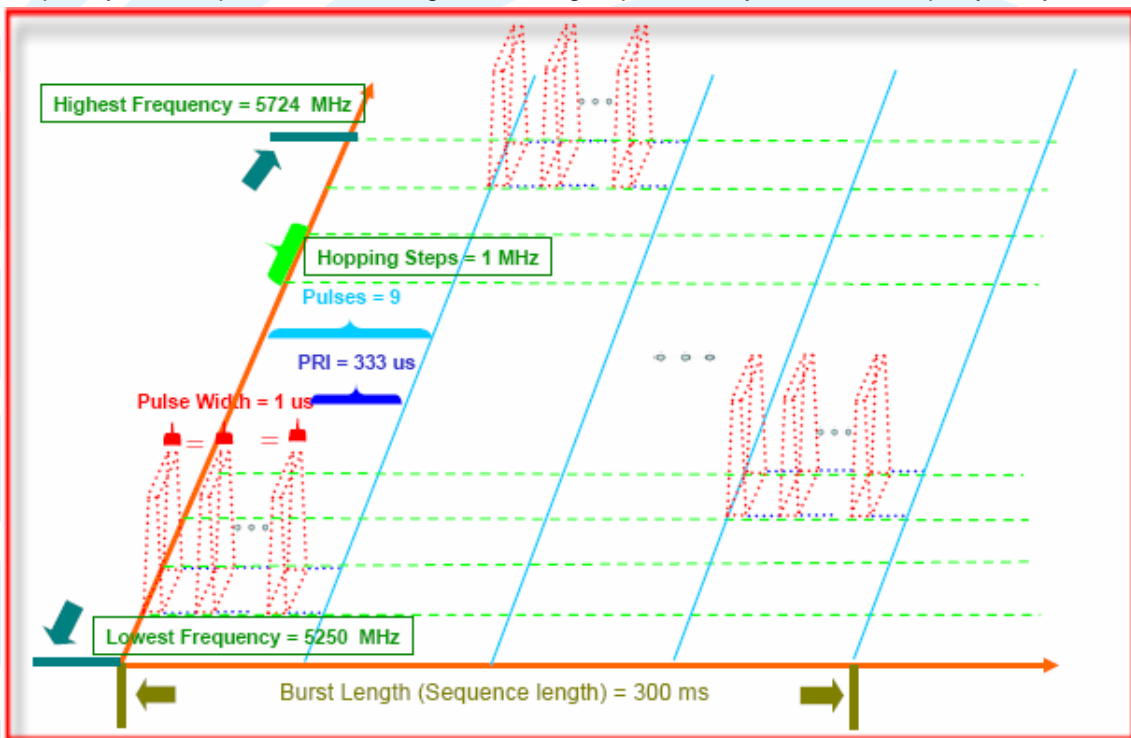

6. CALIBRATION SETUP AND DFS TEST RESULTS

6.1 CALIBRATION OF RADAR WAVEFORM

6.1.1 Radar Waveform Calibration Procedure

The Interference Radar Detection Threshold Level is -64 dBm that had been taken into account the output power range and antenna gain. The following equipment setup was used to calibrate the radiated Radar Waveform. A vector signal generator was utilized to establish the test signal level for radar type 0~6. During this process there were no transmissions by either the Master or Client Device. The spectrum analyzer was switched to the zero span (Time Domain) at the frequency of the Radar Waveform generator. Peak detection was used. The spectrum analyzer resolution bandwidth (RBW) and video bandwidth (VBW) were set to 3 MHz to measure the radar waveform. The vector signal generator amplitude was set so that the power level measured at the spectrum analyzer was -64 dBm. Capture the spectrum analyzer plots on radar waveform.

6.1.2 Conducted Calibration Setup

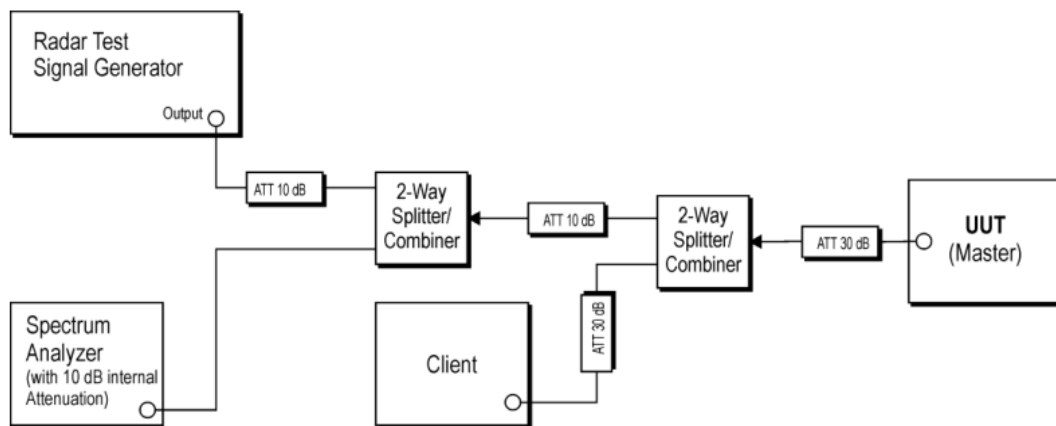

6.1.3 Calibration Deviation

There is no deviation with the original standard.

6.1.4 Radar Waveform Calibration Result

Radar Waveform calibration Plot

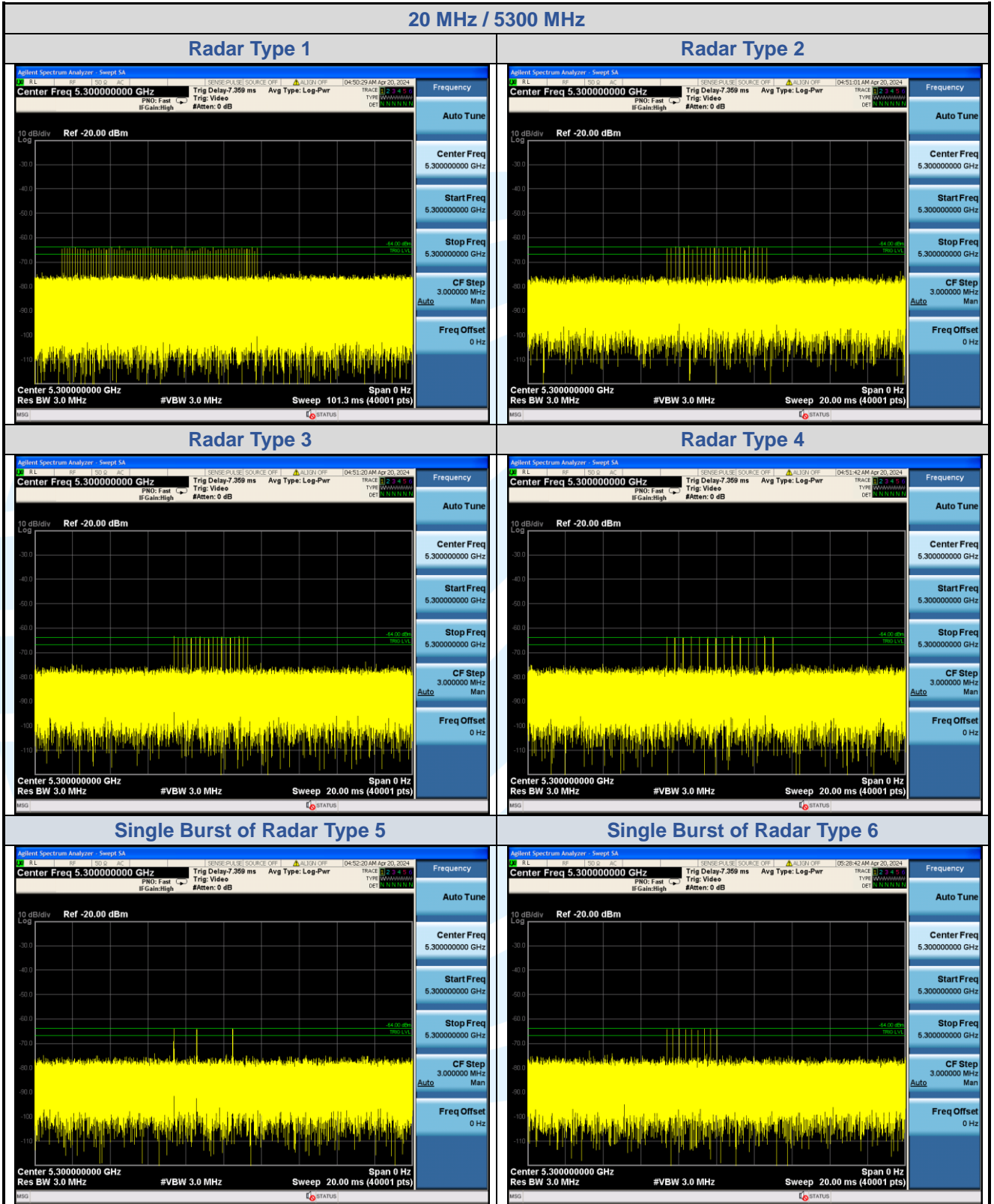

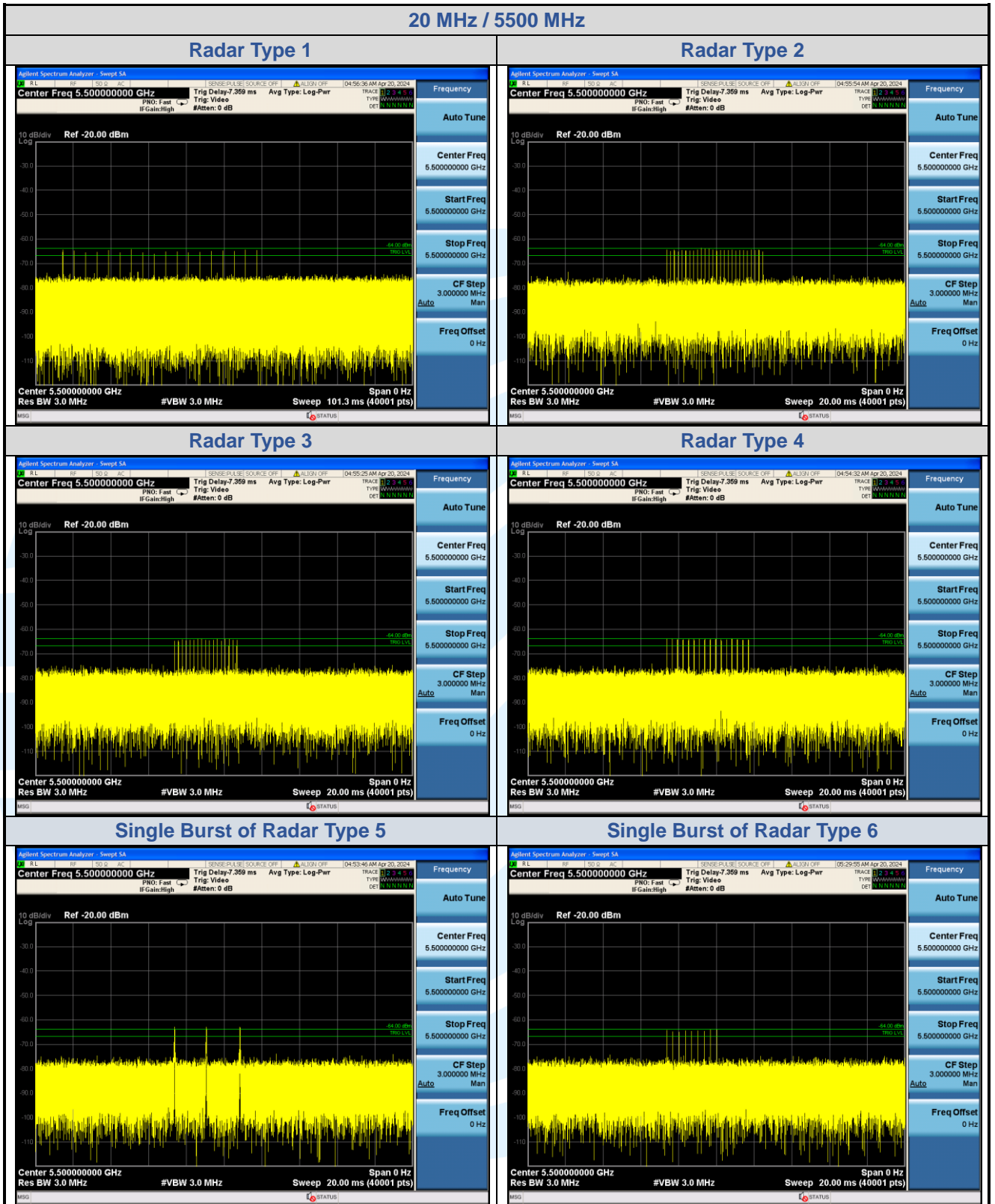

Shenzhen UnionTrust Quality and Technology Co., Ltd.

Address: Unit D/E of 9/F and 16/F, Block A, Building 6, Baoneng science and technology park, Longhua district, Shenzhen, China

Tel: +86-755-28230888

Fax: +86-755-28230886

E-mail: info@uttlab.com

<http://www.uttlab.com>

UTTR-RF-FCCPART15.407-V1.3

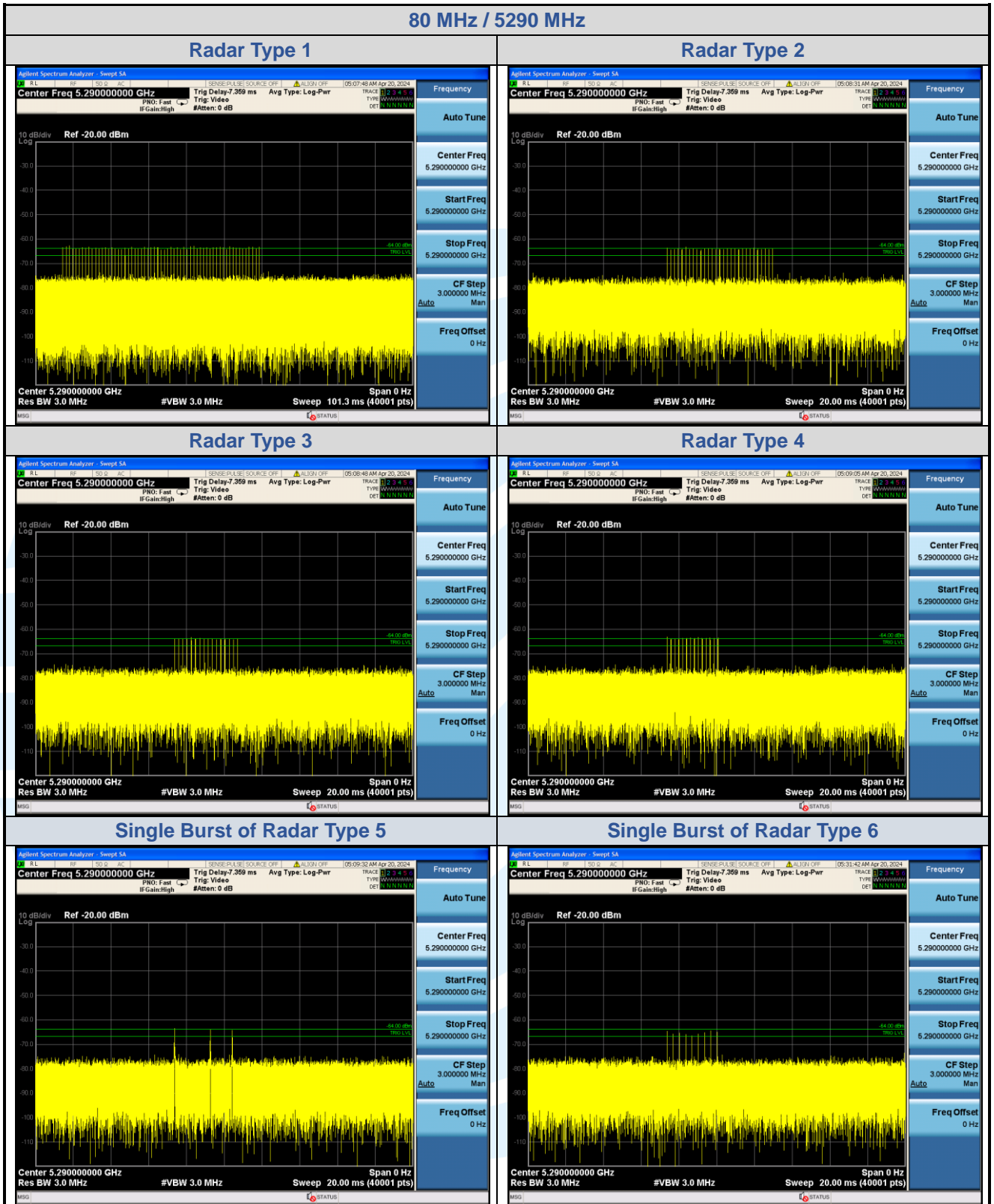

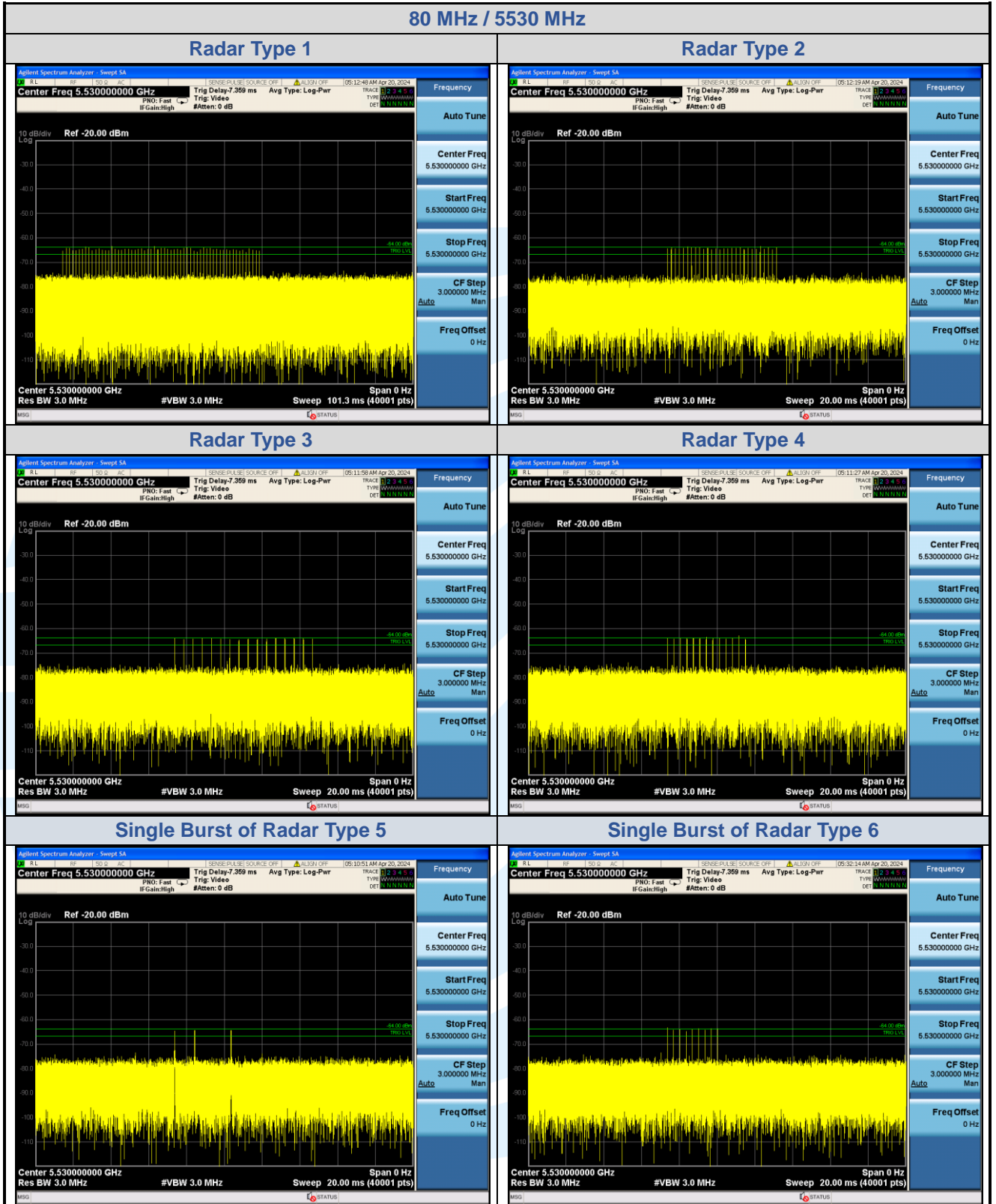

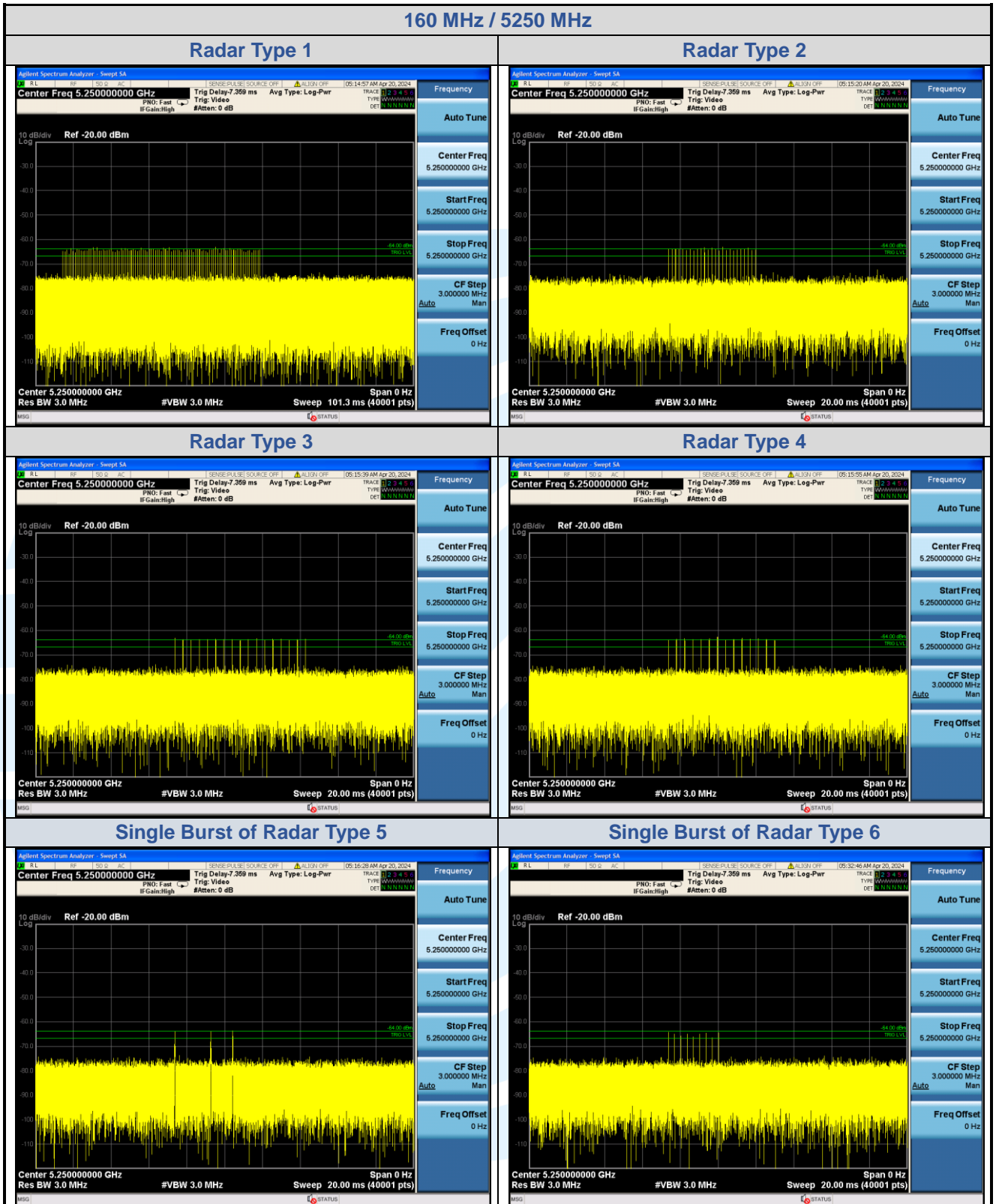

Shenzhen UnionTrust Quality and Technology Co., Ltd.

Address: Unit D/E of 9/F and 16/F, Block A, Building 6, Baoneng science and technology park, Longhua district, Shenzhen, China

Tel: +86-755-28230888

Fax: +86-755-28230886

E-mail: info@uttlab.com

<http://www.uttlab.com>

UTTR-RF-FCCPART15.407-V1.3

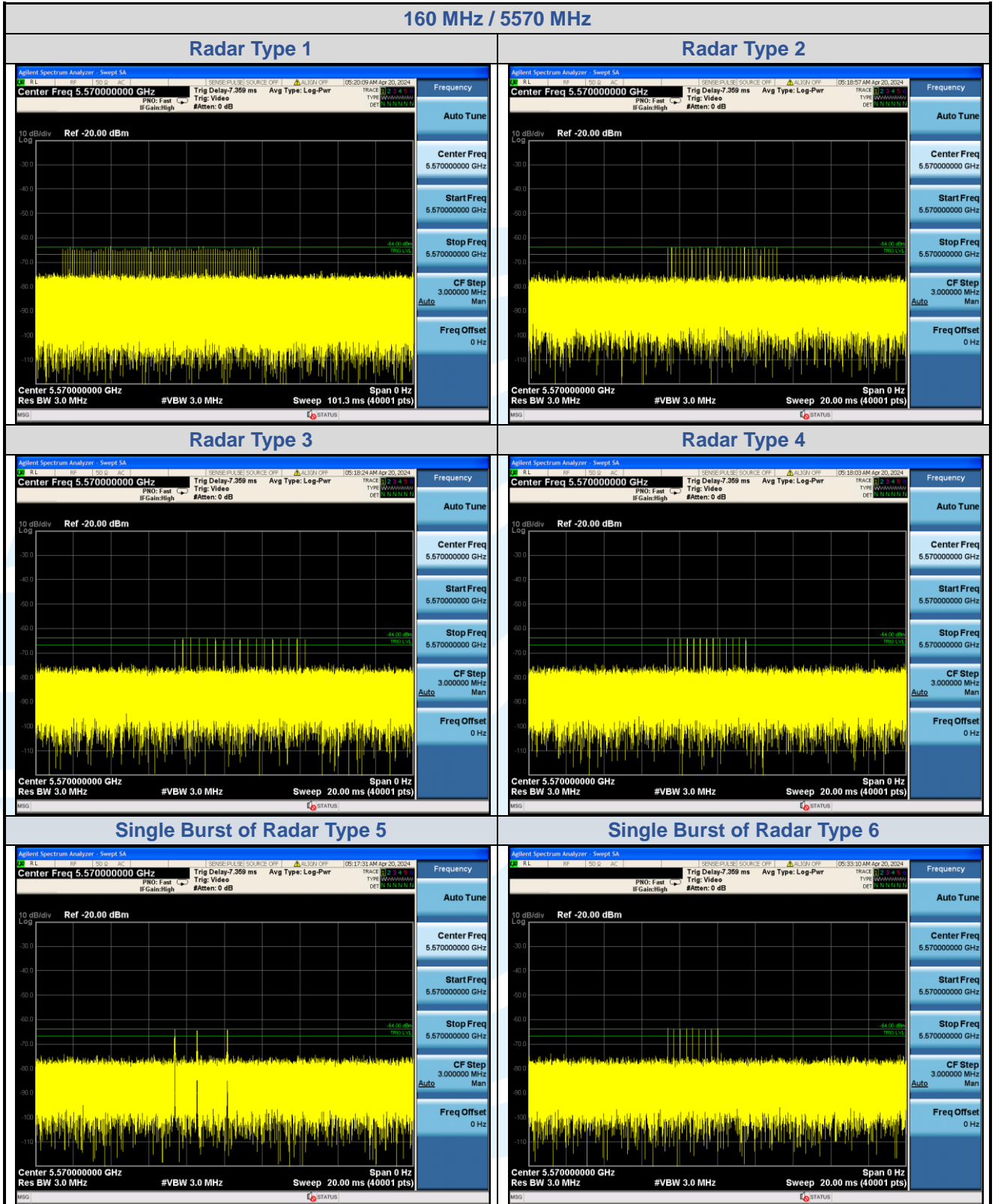

Shenzhen UnionTrust Quality and Technology Co., Ltd.

Address: Unit D/E of 9/F and 16/F, Block A, Building 6, Baoneng science and technology park, Longhua district, Shenzhen, China

Tel: +86-755-28230888

Fax: +86-755-28230886

E-mail: info@uttlab.com

<http://www.uttlab.com>

UTTR-RF-FCCPART15.407-V1.3

6.2 U-NII DETECTION BANDWIDTH (7.8.1)

6.2.1 Limit of U-NII Detection Bandwidth

The U-NII Detection Bandwidth shall contain minimum 100% of the 99% power bandwidth.

During the U-NII Detection Bandwidth detection test, radar type 0 is used and for each frequency step the minimum percentage of detection is 90%. Measurements are performed with no data traffic.

6.2.2 Test Procedures

- (1) Adjust the equipment to produce a single burst of the Short Pulse Radar Type 0 at the center frequency of the EUT Operating Channel at the specified DFS Detection Threshold level.
- (2) (Set the EUT up as a standalone device (no associated Client or Master, as appropriate) and no traffic. Frame based systems will be set to a talk/listen ratio of 0%/100% during this test.
- (3) Generate a single radar burst, and note the response of the EUT. Repeat for a minimum of 10 trials. The EUT must detect the Radar Waveform using the specified U-NII Detection Bandwidth criterion.
- (4) Starting at the center frequency of the EUT operating Channel, increase the radar frequency in 5 MHz steps, repeating the above test sequence, until the detection rate falls below the U-NII Detection Bandwidth criterion specified in report clause 2.3. Repeat this measurement in 1MHz steps at frequencies 5 MHz below where the detection rate begins to fall. Record the highest frequency (denote as F_H) at which detection is greater than or equal to the U-NII Detection Bandwidth criterion. Recording the detection rate at frequencies above F_H is not required to demonstrate compliance.
- (5) Starting at the center frequency of the EUT operating Channel, decrease the radar frequency in 5 MHz steps, repeating the above test sequence, until the detection rate falls below the U-NII Detection Bandwidth criterion specified in report clause 2.3. Repeat this measurement in 1MHz steps at frequencies 5 MHz above where the detection rate begins to fall. Record the lowest frequency (denote as F_L) at which detection is greater than or equal to the U-NII Detection Bandwidth criterion. Recording the detection rate at frequencies below F_L is not required to demonstrate compliance.
- (6) The U-NII Detection Bandwidth is calculated as follows:
- (7) $U\text{-NII Detection Bandwidth} = F_H - F_L$

6.2.3 Test Setup

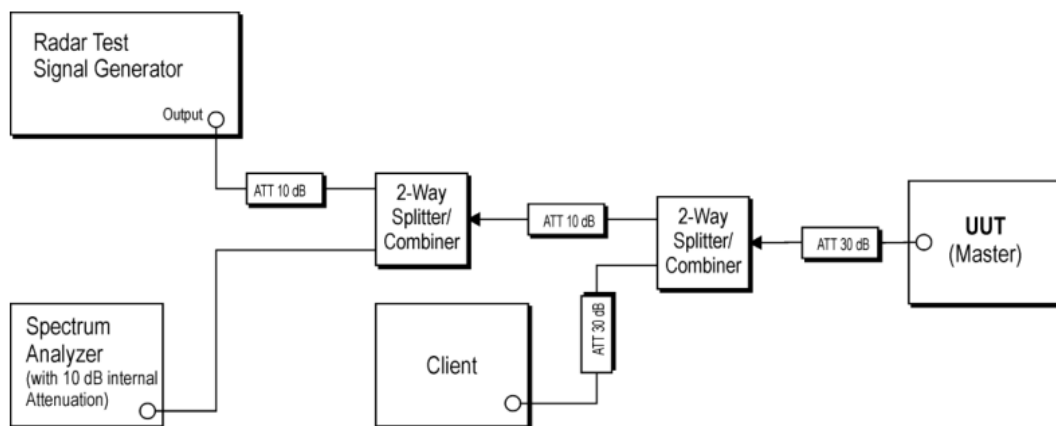

6.2.4 Test Deviation

There is no deviation with the original standard.

6.2.5 Result of U-NII Detection Bandwidth

20MHz / 5300MHz													
Frequency (MHz)	Fc	Trial Number (Detection = Y, No Detection = N)										Rate (%)	F _H /F _L
		1	2	3	4	5	6	7	8	9	10		
5290	-10	Y	Y	Y	Y	Y	Y	Y	Y	Y	Y	100	FL
5291	-9	Y	Y	Y	Y	Y	Y	Y	Y	Y	Y	100	
5292	-8	Y	Y	Y	Y	Y	Y	Y	N	Y	Y	90	
5293	-7	Y	Y	Y	Y	Y	Y	Y	Y	Y	Y	100	
5294	-6	Y	Y	Y	Y	Y	Y	Y	Y	Y	Y	100	
5295	-5	Y	Y	Y	Y	Y	N	Y	Y	Y	Y	90	
5300	0	Y	Y	Y	Y	Y	Y	Y	Y	Y	Y	100	
5305	+5	Y	Y	Y	Y	Y	Y	N	Y	Y	Y	90	
5306	+6	Y	Y	Y	Y	Y	Y	Y	Y	Y	Y	100	
5307	+7	Y	Y	Y	Y	Y	Y	Y	Y	Y	Y	100	
5308	+8	Y	Y	Y	Y	Y	Y	Y	Y	N	Y	90	
5309	+9	Y	Y	Y	Y	Y	N	Y	Y	Y	Y	90	
5310	+10	Y	Y	Y	Y	Y	Y	Y	Y	Y	Y	100	FH
Detection Bandwidth = F _H – F _L = 5310 – 5290 = 20 MHz EUT 99% Bandwidth = 19.106 MHz (Refer to channel 60)													

40MHz / 5310MHz													
Frequency (MHz)	Fc	Trial Number (Detection = Y, No Detection = N)										Rate (%)	F _H /F _L
		1	2	3	4	5	6	7	8	9	10		
5290	-20	-	-	-	-	-	-	-	-	-	-	-	
5291	-19	Y	Y	Y	Y	N	Y	Y	Y	Y	Y	90	FL
5292	-18	Y	Y	Y	Y	Y	Y	Y	Y	Y	Y	100	
5293	-17	Y	Y	Y	Y	Y	Y	Y	Y	Y	Y	100	
5294	-16	Y	Y	Y	Y	N	Y	Y	Y	Y	Y	90	
5295	-15	Y	Y	Y	Y	Y	Y	Y	Y	N	Y	90	
5300	-10	Y	Y	Y	Y	Y	Y	Y	Y	Y	Y	100	
5305	-5	Y	Y	Y	Y	Y	Y	Y	Y	Y	Y	100	
5310	0	Y	Y	Y	Y	Y	Y	Y	Y	Y	Y	100	
5315	+5	Y	Y	Y	Y	N	Y	Y	Y	Y	Y	90	
5320	+10	Y	Y	Y	Y	Y	Y	Y	Y	Y	Y	100	
5325	+15	Y	Y	Y	Y	Y	Y	Y	Y	Y	Y	100	
5326	+16	Y	Y	Y	Y	Y	Y	N	Y	Y	Y	90	
5327	+17	Y	Y	Y	Y	Y	Y	Y	Y	N	Y	90	
5328	+18	Y	Y	Y	Y	Y	Y	Y	Y	Y	Y	100	
5329	+19	Y	Y	Y	Y	Y	Y	Y	Y	Y	Y	100	FH
5330	+20	-	-	-	-	-	-	-	-	-	-	-	
Detection Bandwidth = F _H – F _L = 5329 – 5291 = 38 MHz EUT 99% Bandwidth = 37.642 MHz (Refer to channel 62)													

20MHz / 5500MHz													
Frequency (MHz)	Fc	Trial Number (Detection = Y, No Detection = N)										Rate (%)	F _H /F _L
		1	2	3	4	5	6	7	8	9	10		
5490	-10	Y	Y	Y	Y	Y	N	Y	Y	Y	Y	90	FL
5491	-9	Y	Y	Y	Y	Y	Y	Y	Y	N	Y	90	
5492	-8	Y	Y	Y	Y	Y	Y	Y	Y	Y	Y	100	
5493	-7	Y	Y	Y	Y	Y	Y	Y	Y	Y	Y	100	
5494	-6	Y	Y	Y	Y	Y	Y	Y	Y	Y	Y	100	
5495	-5	Y	Y	Y	Y	Y	Y	Y	Y	Y	Y	100	
5500	0	Y	Y	Y	Y	Y	Y	Y	Y	N	Y	90	
5505	+5	Y	Y	Y	Y	Y	Y	Y	Y	Y	Y	100	
5506	+6	Y	Y	Y	Y	N	Y	Y	Y	Y	Y	90	
5507	+7	Y	Y	Y	Y	Y	Y	Y	Y	Y	Y	100	
5508	+8	Y	Y	Y	Y	Y	Y	Y	Y	Y	Y	100	
5509	+9	Y	Y	Y	Y	Y	Y	Y	N	Y	Y	90	
5510	+10	Y	Y	Y	Y	Y	Y	Y	Y	Y	Y	100	FH

Detection Bandwidth = F_H – F_L = 5510 – 5490 = 20 MHz
 EUT 99% Bandwidth = 19.161 MHz (Refer to channel 100)

40MHz / 5510MHz													
Frequency (MHz)	Fc	Trial Number (Detection = Y, No Detection = N)										Rate (%)	F _H /F _L
		1	2	3	4	5	6	7	8	9	10		
5490	-20	-	-	-	-	-	-	-	-	-	-	-	
5491	-19	Y	Y	Y	Y	Y	Y	Y	Y	Y	Y	100	FL
5492	-18	Y	N	Y	Y	Y	Y	Y	Y	Y	Y	90	
5493	-17	Y	Y	Y	Y	Y	Y	Y	Y	Y	Y	100	
5494	-16	Y	Y	Y	Y	Y	Y	Y	Y	Y	Y	100	
5495	-15	Y	Y	Y	Y	Y	Y	Y	Y	N	Y	90	
5500	-10	Y	Y	Y	Y	Y	Y	Y	Y	Y	N	90	
5505	-5	Y	Y	Y	Y	Y	Y	Y	Y	Y	Y	100	
5510	0	Y	Y	Y	Y	Y	Y	Y	Y	Y	Y	100	
5515	+5	Y	Y	Y	Y	Y	Y	Y	Y	Y	Y	100	
5520	+10	Y	Y	Y	Y	N	Y	Y	Y	Y	Y	90	
5525	+15	Y	Y	Y	Y	Y	Y	Y	Y	Y	Y	100	
5526	+16	Y	Y	Y	Y	Y	Y	Y	N	Y	Y	90	
5527	+17	Y	N	Y	Y	Y	Y	Y	Y	Y	Y	90	
5528	+18	Y	Y	Y	Y	Y	Y	Y	Y	Y	Y	100	
5529	+19	Y	Y	Y	Y	Y	Y	Y	Y	Y	Y	100	FH
5530	+20	-	-	-	-	-	-	-	-	-	-	-	

Detection Bandwidth = F_H – F_L = 5529- 5491 = 38 MHz
 EUT 99% Bandwidth = 37.615 MHz (Refer to channel 102)