

DFS TEST REPORT

Product Name: Mid-Tier 802.11ac Wi-Fi Access Point
Trade Mark: GRANDSTREAM
Model No. / HVIN: GWN7602
Report Number: 191120011RFC-2
Test Standards: FCC 47 CFR Part 15 Subpart E
RSS-247 Issue 2
FCC ID: YZZGWN7602
IC: 11964A-GWN7602
Test Result: PASS
Date of Issue: February 28, 2020

Prepared for:

Grandstream Networks, Inc.
126 Brookline Ave., 3rd Floor Boston, MA 02215, USA

Prepared by:

Shenzhen UnionTrust Quality and Technology Co., Ltd.
16/F, Block A, Building 6, Baoneng Science and Technology Park,
Qingxiang Road No.1, Longhua New District, Shenzhen, China
TEL: +86-755-2823 0888
FAX: +86-755-2823 0886

Prepared by: _____



Billy Li
Technical Director

Reviewed by: _____

Kevin Liang
Assistant Manager

Approved by: _____

Date: February 28, 2020

Shenzhen UnionTrust Quality and Technology Co., Ltd.

Address: 16/F, Block A, Building 6, Baoneng Science and Technology Park, Qingxiang Road No.1, Longhua New District, Shenzhen, China
Tel: +86-755-28230888 Fax: +86-755-28230886 E-mail: info@uttlab.com <http://www.uttlab.com>

Version

Version No.	Date	Description
V1.0	February 28, 2020	Original

**Shenzhen UnionTrust Quality and Technology Co., Ltd.**

Address: 16/F, Block A, Building 6, Baoneng Science and Technology Park, Qingxiang Road No.1, Longhua New District, Shenzhen, China

Tel: +86-755-28230888

Fax: +86-755-28230886

E-mail: info@uttlab.com<http://www.uttlab.com>UTTR-RF-FCCPART15.407-V1.0

CONTENTS

1. GENERAL INFORMATION	5
1.1 CLIENT INFORMATION	5
1.2 EUT INFORMATION	5
1.2.1 GENERAL DESCRIPTION OF EUT	5
1.2.2 DESCRIPTION OF ACCESSORIES	5
1.3 PRODUCT SPECIFICATION SUBJECTIVE TO THIS STANDARD	5
1.4 DESCRIPTION OF SUPPORT UNITS	6
1.5 TEST LOCATION	6
1.6 TEST FACILITY	6
1.7 DEVIATION FROM STANDARDS	7
1.8 ABNORMALITIES FROM STANDARD CONDITIONS	7
1.9 OTHER INFORMATION REQUESTED BY THE CUSTOMER	7
2. TEST SUMMARY	8
3. EQUIPMENT LIST	9
4. ENVIRONMENTAL CONDITIONS FOR TESTING	10
5. REQUIREMENTS AND PARAMETERS FOR DFS TEST	11
5.1 REFERENCE DOCUMENTS FOR TESTING	11
5.2 APPLICABILITY OF DFS REQUIREMENTS	12
5.3 DFS DETECTION THRESHOLDS	13
5.4 DFS RESPONSE REQUIREMENT VALUES	14
5.5 SHORT PULSE RADAR TEST WAVEFORMS	15
5.6 LONG PULSE RADAR TEST WAVEFORM	16
5.7 FREQUENCY HOPPING RADAR TEST WAVEFORM	18
6. CALIBRATION SETUP AND DFS TEST RESULTS	19
6.1 CALIBRATION OF RADAR WAVEFORM	19
6.1.1 RADAR WAVEFORM CALIBRATION PROCEDURE	19
6.1.2 CONDUCTED CALIBRATION SETUP	19
6.1.3 CALIBRATION DEVIATION	19
6.1.4 RADAR WAVEFORM CALIBRATION RESULT	20
6.2 U-NII DETECTION BANDWIDTH (7.8.1)	26
6.2.1 LIMIT OF U-NII DETECTION BANDWIDTH	26
6.2.2 TEST PROCEDURES	26
6.2.3 TEST SETUP	26
6.2.4 TEST DEVIATION	26
6.2.5 RESULT OF U-NII DETECTION BANDWIDTH	27
6.3 CHANNEL AVAILABILITY CHECK (7.8.2)	31
6.3.1 LIMIT OF CHANNEL AVAILABILITY CHECK	31
6.3.2 TEST PROCEDURES	31
6.3.3 TEST SETUP	33
6.3.4 TEST DEVIATION	33
6.3.5 RESULT OF CHANNEL AVAILABILITY CHECK TIME	34
6.4 IN-SERVICE MONITORING: CHANNEL MOVE TIME, CHANNEL CLOSING TRANSMISSION TIME AND NON-OCCUPANCY PERIOD (7.8.3)	40
6.4.1 LIMIT OF IN-SERVICE MONITORING	40
6.4.2 TEST PROCEDURES	40
6.4.3 TEST SETUP	41
6.4.4 TEST DEVIATION	41
6.4.5 RESULT OF CHANNEL MOVE TIME, CHANNEL CLOSING TRANSMISSION TIME AND NON-OCCUPANCY PERIOD FOR CLIENT BEACON TEST	41
6.4.6 CHANNEL MOVE TIME, CHANNEL CLOSING TRANSMISSION TIME AND NON-OCCUPANCY PERIOD TEST PLOTS	42
6.4.7 DATA TRAFFIC CHANNEL LOADING AND NOISE FLOOR PLOTS	44
6.5 STATISTICAL PERFORMANCE CHECK (7.8.4)	45

Shenzhen UnionTrust Quality and Technology Co., Ltd.

Address: 16/F, Block A, Building 6, Baoneng Science and Technology Park, Qingxiang Road No.1, Longhua New District, Shenzhen, China

Tel: +86-755-28230888

Fax: +86-755-28230886

E-mail: info@uttlab.com

<http://www.uttlab.com>

UTTR-RF-FCCPART15.407-V1.0

6.5.2 TEST PROCEDURES46
6.5.3 TEST SETUP47
6.5.4 TEST DEVIATION47
6.5.5 RESULT OF STATISTICAL PERFORMANCE CHECK.....48
APPENDIX 1 PHOTOS OF TEST SETUP.....54
APPENDIX 2 PHOTOS OF EUT CONSTRUCTIONAL DETAILS.....54



1. GENERAL INFORMATION

1.1 CLIENT INFORMATION

Applicant:	Grandstream Networks, Inc.
Address of Applicant:	126 Brookline Ave., 3rd Floor Boston, MA 02215, USA
Manufacturer:	Grandstream Networks, Inc.
Address of Manufacturer:	126 Brookline Ave., 3rd Floor Boston, MA 02215, USA

1.2 EUT INFORMATION

1.2.1 General Description of EUT

Product Name:	Mid-Tier 802.11ac Wi-Fi Access Point		
Model No. / HVIN:	GWN7602		
Trade Mark:	GRANDSTREAM		
DUT Stage:	Identical Prototype		
EUT Supports Function:	2.4 GHz ISM Band:	IEEE 802.11b/g/n	
	5 GHz U-NII Bands:	5 150 MHz to 5 250 MHz	IEEE 802.11a/n/ac
		5 250 MHz to 5 350 MHz	IEEE 802.11a/n/ac
		5 470 MHz to 5 725 MHz	IEEE 802.11a/n/ac
5 725 MHz to 5 850 MHz		IEEE 802.11a/n/ac	
Software Version:	1.0.0.4		
Hardware Version:	V1		
Sample Received Date:	November 20, 2019		
Sample Tested Date:	November 20, 2019 to February 19, 2020		

1.2.2 Description of Accessories

None.

1.3 PRODUCT SPECIFICATION SUBJECTIVE TO THIS STANDARD

Frequency Bands:	5150 MHz to 5250 MHz (U-NII-1)
	5250 MHz to 5350 MHz (U-NII-2A)
	5470 MHz to 5725 MHz (U-NII-2C)
	5725 MHz to 5850 MHz (U-NII-3)
Frequency Ranges:	5180 MHz to 5240 MHz
	5260 MHz to 5320 MHz
	5500 MHz to 5700 MHz
	5745 MHz to 5825 MHz
Support Standards:	IEEE 802.11a/n/ac
TPC Function:	Not Support
DFS Operational mode:	Master
Type of Modulation:	IEEE 802.11a: OFDM(64QAM, 16QAM, QPSK, BPSK)
	IEEE 802.11n: OFDM(64QAM, 16QAM, QPSK, BPSK)
	IEEE 802.11ac: OFDM(256QAM, 64QAM, 16QAM, QPSK, BPSK)
Channel Spacing:	IEEE 802.11a/n-HT20/ac-VHT20: 20 MHz
	IEEE 802.11n-HT40/ac-VHT40: 40 MHz
	IEEE 802.11ac-VHT80: 80 MHz
Data Rate:	IEEE 802.11a: Up to 54 Mbps
	IEEE 802.11n-HT20: Up to MCS15

Shenzhen UnionTrust Quality and Technology Co., Ltd.

Address: 16/F, Block A, Building 6, Baoneng Science and Technology Park, Qingxiang Road No.1, Longhua New District, Shenzhen, China

Tel: +86-755-28230888

Fax: +86-755-28230886

E-mail: info@uttlab.com

<http://www.uttlab.com>

UTTR-RF-FCCPART15.407-V1.0

	IEEE 802.11n-HT40: Up to MCS15
	IEEE 802.11ac-VHT20: Up to MCS8
	IEEE 802.11ac-VHT40: Up to MCS9
	IEEE 802.11ac-VHT80: Up to MCS9

1.4 DESCRIPTION OF SUPPORT UNITS

The EUT has been tested with associated equipment below.

1) Support Equipment

Description	Manufacturer	Model No.	Serial Number	Supplied by
Notebook	Lenovo	E450	SL10G10780	UnionTrust
Phone	MI	MIX 2S	N/A	UnionTrust
Compact PoE Switch	N/A	LS5004P	N/A	Applicant

2) Support Cable

Cable No.	Description	Connector	Length	Supplied by
1	Antenna Cable	SMA	0.3 Meter	UnionTrust
2	Lan*3	RJ-45	1.5 Meter	UnionTrust

1.5 TEST LOCATION

Shenzhen UnionTrust Quality and Technology Co., Ltd.

Address: 16/F, Block A, Building 6, Baoneng Science and Technology Park, Qingxiang Road No.1, Longhua New District, Shenzhen, China 518109
 Telephone: +86 (0) 755 2823 0888
 Fax: +86 (0) 755 2823 0886

1.6 TEST FACILITY

The test facility is recognized, certified, or accredited by the following organizations:

CNAS-Lab Code: L9069

The measuring equipment utilized to perform the tests documented in this report has been calibrated once a year or in accordance with the manufacturer's recommendations, and is traceable under the ISO/IEC/EN 17025 to international or national standards. Equipment has been calibrated by accredited calibration laboratories.

A2LA-Lab Certificate No.: 4312.01

Shenzhen UnionTrust Quality and Technology Co., Ltd. has been accredited by A2LA for technical competence in the field of electrical testing, and proved to be in compliance with ISO/IEC 17025: 2005 General Requirements for the Competence of Testing and Calibration Laboratories and any additional program requirements in the identified field of testing.

ISED Wireless Device Testing Laboratories

CAB identifier: CN0032

FCC Accredited Lab.

Designation Number: CN1194

Shenzhen UnionTrust Quality and Technology Co., Ltd.

Address: 16/F, Block A, Building 6, Baoneng Science and Technology Park, Qingxiang Road No.1, Longhua New District, Shenzhen, China

Tel: +86-755-28230888

Fax: +86-755-28230886

E-mail: info@uttlab.com

<http://www.uttlab.com>

UTTR-RF-FCCPART15.407-V1.0

Test Firm Registration Number: 259480

1.7 DEVIATION FROM STANDARDS

None.

1.8 ABNORMALITIES FROM STANDARD CONDITIONS

None.

1.9 OTHER INFORMATION REQUESTED BY THE CUSTOMER

None.



2. TEST SUMMARY

Test Requirement	Measured				Limit	Result
	5250 MHz to 5350 MHz (U-NII-2A)		5470 MHz to 5725 MHz (U-NII-2C)			
	20 MHz 5300 MHz	40 MHz 5310 MHz	20 MHz 5500 MHz	40 MHz 5510 MHz		
Channel Availability Check Time	> 60 sec	> 60 sec	> 60 sec	> 60 sec	> 60sec	PASS
U-NII Detection Bandwidth	18 MHz	36 MHz	18 MHz	37 MHz	> 100% of the U-NII 99% transmission power bandwidth	PASS
Channel Move Time	Note1	Note1	Note1	Note1	< 10 sec	PASS
Channel Closing Transmission Time	Note1	Note1	Note1	Note1	< 200 ms + aggregate of 60 ms over remaining 10 s period	PASS
Non-Occupancy Period Test	No transmission or Beacons occurred	No transmission or Beacons occurred	No transmission or Beacons occurred	No transmission or Beacons occurred	> 30 minutes	PASS

Remark: Note 1 only require test widest bandwidth

Test Requirement	Measured		Limit	Result
	5250 MHz to 5350 MHz (U-NII-2A)	5470 MHz to 5725 MHz (U-NII-2C)		
	80 MHz 5290 MHz	80 MHz 5530 MHz		
Channel Availability Check Time	> 60 sec	> 60 sec	> 60sec	PASS
U-NII Detection Bandwidth	77 MHz	77 MHz	> 100% of the U-NII 99% transmission power bandwidth	PASS
Channel Move Time	0.657 sec	0.597 sec	< 10 sec	PASS
Channel Closing Transmission Time	<200ms + 10.2 ms (aggregate)	<200ms + 16.2 ms (aggregate)	< 200 ms + aggregate of 60 ms over remaining 10 s period	PASS
Non-Occupancy Period Test	No transmission or Beacons occurred	No transmission or Beacons occurred	> 30 minutes	PASS

3. EQUIPMENT LIST

Conducted RF test Equipment List						
Used	Equipment	Manufacturer	Model No.	Serial Number	Cal. date (mm dd, yyyy)	Cal. Due date (mm dd, yyyy)
<input checked="" type="checkbox"/>	EXA Spectrum Analyzer	KEYSIGHT	N9010A	MY51440197	Nov. 24, 2019	Nov. 23, 2020
<input checked="" type="checkbox"/>	MXG X-Series RF Vector Signal Generator	KEYSIGHT	N5182B	MY51350267	Nov. 24, 2019	Nov. 23, 2020
<input checked="" type="checkbox"/>	Receiver	R&S	ESR7	1316.3003K07-101181-K3	Nov. 24, 2019	Nov. 23, 2020



4. ENVIRONMENTAL CONDITIONS FOR TESTING

Environment Parameter	Selected Values During Tests		
Test Condition	Ambient		
	Temperature (°C)	Voltage	Relative Humidity (%)
NT/NV	+15 to +35	120V~60Hz and 240V~50Hz	20 to 75
Remark: 1) NV: Normal Voltage; NT: Normal Temperature			



5. REQUIREMENTS AND PARAMETERS FOR DFS TEST

5.1 REFERENCE DOCUMENTS FOR TESTING

No.	Identity	Document Title
1	FCC 47 CFR Part 15	Radio Frequency Devices
2	RSS-247 Issue 2	Digital Transmission Systems (DTSs), Frequency Hopping Systems (FHSs) and Licence-Exempt Local Area Network (LE-LAN) Devices
3	KDB 905462 D06 802.11 Channel Plans New Rules v02	Operation in U-NII bands -802.11 channel PLAN(§15.407)
4	KDB 905462 D02 UNII DFS Compliance Procedures New Rules v02	Compliance measurement procedures for Unlicensed –National Information Infrastructure devices operates in the frequency bands 5250 MHz to 5350 MHz and 5470 MHz to 5725 MHz bands incorporating dynamic frequency selection
5	KDB 905462 D04 Test Mode New Rules v01	Operational modes suggested for DFS testing

5.2 APPLICABILITY OF DFS REQUIREMENTS

EUT Operating Mode:

DFS Operational mode	Operating Frequency Range	
	5250 MHz to 5350 MHz	5470 MHz to 5725 MHz
Master	✓	✓

Applicability:

The following table from KDB905462 and the lists of the applicable requirements for the DFS testing.

Table 1 – Applicability of DFS Requirements Prior to Use of a Channel:

Requirement	Operational Mode		
	Master	Client Without Radar Detection	Client With Radar Detection
Non-Occupancy Period	Yes	Not required	Yes
DFS Detection Threshold	Yes	Not required	Yes
Channel Availability Check Time	Yes	Not required	Not required
U-NII Detection Bandwidth	Yes	Not required	Yes

Table 2 – Applicability of DFS requirements during normal operation:

Requirement	Operational Mode		
	Master Device or	Client Without Radar Detection	Client with Radar Detection
DFS Detection Threshold	Yes	Not required	Yes
Channel Closing Transmission Time	Yes	Yes	Yes
Channel Move Time	Yes	Yes	Yes
U-NII Detection Bandwidth	Yes	Not required	Yes
Client Beacon Test	N/A	Yes	Yes
Additional requirements for devices with multiple bandwidth modes	Operational Mode		
	Master Device or Client with Radar Detection	Client Without Radar Detection	
U-NII Detection Bandwidth and Statistical Performance Check	All BW modes must be tested	Not required	
Channel Move Time and Channel Closing Transmission Time	Test using widest BW mode available	Test using the widest BW mode available for the link	
All other tests	Any single BW mode	Not required	
<p>Note: Frequencies selected for statistical performance check (Section 7.8.4) should include several frequencies within the radar detection bandwidth and frequencies near the edge of the radar detection bandwidth. For 802.11 devices it is suggested to select frequencies in each of the bonded 20 MHz channels and the channel center frequency.</p>			

5.3 DFS DETECTION THRESHOLDS

Table 3 – DFS Detection Thresholds for Master Devices and Client Devices with Radar Detection:

Maximum Transmit Power	Value (See Notes 1, 2, and 3)
EIRP \geq 200 mw	-64 dBm
EIRP < 200 mW and power spectral density < 10 dBm/MHz	-62 dBm
EIRP < 200 mw that do not meet the power spectral density requirement	-64 dBm
<p>Note 1: This is the level at the input of the receiver assuming a 0 dBi receive antenna.</p> <p>Note 2: Throughout these test procedures an additional 1 dB has been added to the amplitude of the test transmission waveforms to account for variations in measurement equipment. This will ensure that the test signal is at or above the detection threshold level to trigger a DFS response.</p> <p>Note3: EIRP is based on the highest antenna gain. For MIMO devices refer to KDB Publication 662911 D01.</p>	

The radar Detection Threshold, lowest antenna gain is the parameter of Interference radar DFS detection threshold, The Interference Detection Threshold is -64 dBm

5.4 DFS RESPONSE REQUIREMENT VALUES

Table 4 – DFS Radar Signal Parameter Values:

Parameter	Value
Non-occupancy period	Minimum 30 minutes
Channel Availability Check Time	60 seconds
Channel Move Time	10 seconds (See Note 1.)
Channel Closing Transmission Time	200 milliseconds + an aggregate of 60 milliseconds over remaining 10 second period. (See Notes 1 and 2.)
U-NII Detection Bandwidth	Minimum 100% of the U-NII 99% transmission power bandwidth. (See Note 3.)
<p>Note 1: Channel Move Time and the Channel Closing Transmission Time should be performed with Radar Type 0. The measurement timing begins at the end of the Radar Type 0 burst.</p> <p>Note 2: The Channel Closing Transmission Time is comprised of 200 milliseconds starting at the beginning of the Channel Move Time plus any additional intermittent control signals required to facilitate a Channel move (an aggregate of 60 milliseconds) during the remainder of the 10 second period. The aggregate duration of control signals will not count quiet periods in between transmissions.</p> <p>Note 3: During the U-NII Detection Bandwidth detection test, radar type 0 should be used. For each frequency step the minimum percentage of detection is 90 percent. Measurements are performed with no data traffic.</p>	

5.5 SHORT PULSE RADAR TEST WAVEFORMS

DFS Radar Signal Parameter:

Radar Type 0 was used in the evaluation of the Client device for the purpose of measuring the Channel Move Time and the Channel Closing Transmission Time

Short Pulse Radar Test Waveforms

Radar Type	Pulse Width (μsec)	PRI (μsec)	Number of Pulses	Minimum Percentage of Successful Detection	Minimum Trials
0	1	1428	18	See Note 1.	See Note 1.
1	1	Test A Test B	Roundup $\left\{ \begin{matrix} \left(\frac{1}{360} \right) \\ \left(\frac{19 \cdot 10^6}{PRI_{\mu sec}} \right) \end{matrix} \right\}$	60%	30
2	1-5	150-230	23-29	60%	30
3	6-10	200-500	16-18	60%	30
4	11-20	200-500	12-16	60%	30
Aggregate (Radar Types 1-4)				80%	120
Note 1: Short Pulse Radar Type 0 should be used for the detection bandwidth test, channel move time, and channel closing time tests.					

Test A: 15 unique PRI values randomly selected from the list of 23 PRI values in Table 5a

Test B: 15 unique PRI values randomly selected within the range of 518-3066 μsec, with a minimum increment of 1 μsec, excluding PRI values selected in Test A

A minimum of 30 unique waveforms are required for each of the Short Pulse Radar Types 2 through 4. If more than 30 waveforms are used for Short Pulse Radar Types 2 through 4, then each additional waveform must also be unique and not repeated from the previous waveforms.

If more than 30 waveforms are used for Short Pulse Radar Type 1, then each additional waveform is generated with Test B and must also be unique and not repeated from the previous waveforms in Tests A or B.

The aggregate is the average of the percentage of successful detections of short pulse radar types 1-4

5.6 LONG PULSE RADAR TEST WAVEFORM

Long Pulse Radar Test Waveform

Radar Type	Pulse Width (µsec)	Chirp Width (MHz)	PRI (µsec)	Number of Pulses per Burst	Number of Bursts	Minimum Percentage of Successful Detection	Minimum Trials
5	50-100	5-20	1000-2000	1-3	8-20	80%	30

The parameters for this waveform are randomly chosen. Thirty unique waveforms are required for the Long Pulse radar test signal. If more than 30 waveforms are used for the Long Pulse radar test signal, then each additional waveform must also be unique and not repeated from the previous waveforms. Each waveform is defined as follows:

- (1) The transmission period for the Long Pulse Radar test signal is 12 seconds.
- (2) There are a total of 8 to 20 Bursts in the 12 second period, with the number of Bursts being randomly chosen. This number is Burst_Count.
- (3) Each Burst consists of 1 to 3 pulses, with the number of pulses being randomly chosen. Each Burst within the 12 second sequence may have a different number of pulses.
- (4) The pulse width is between 50 and 100 microseconds, with the pulse width being randomly chosen. Each pulse within a Burst will have the same pulse width. Pulses in different Bursts may have different pulse widths.
- (5) Each pulse has a linear FM chirp between 5 and 20 MHz, with the chirp width being randomly chosen. Each pulse within a Burst will have the same chirp width. Pulses in different Bursts may have different chirp widths. The chirp is centered on the pulse. For example, with a radar frequency of 5300 MHz and a 20 MHz chirped signal, the chirp starts at 5290 MHz and ends at 5310 MHz.
- (6) If more than one pulse is present in a Burst, the time between the pulses will be between 1000 and 2000 microseconds, with the time being randomly chosen. If three pulses are present in a Burst, the time between the first and second pulses is chosen independently of the time between the second and third pulses.
- (7) The 12 second transmission period is divided into even intervals. The number of intervals is equal to Burst_Count. Each interval is of length $(12,000,000 / \text{Burst_Count})$ microseconds. Each interval contains one Burst. The start time for the Burst, relative to the beginning of the interval, is between 1 and $[(12,000,000 / \text{Burst_Count}) - (\text{Total Burst Length}) + (\text{One Random PRI Interval})]$ microseconds, with the start time being randomly chosen. The step interval for the start time is 1 microsecond. The start time for each Burst is chosen independently.

A representative example of a Long Pulse radar test waveform:

- (1) The total test signal length is 12 seconds.
- (2) 8 Bursts are randomly generated for the Burst_Count.
- (3) Burst 1 has 2 randomly generated pulses.
- (4) The pulse width (for both pulses) is randomly selected to be 75 microseconds.
- (5) The PRI is randomly selected to be at 1213 microseconds.
- (6) Bursts 2 through 8 are generated using steps 3 – 5.
- (7) Each Burst is contained in even intervals of 1,500,000 microseconds. The starting location for Pulse 1, Burst 1 is randomly generated (1 to 1,500,000 minus the total Burst 1 length + 1 random PRI interval) at the 325,001 microsecond step. Bursts 2 through 8 randomly fall in successive 1,500,000 microsecond intervals (i.e. Burst 2 falls in the 1,500,001 – 3,000,000 microsecond range).

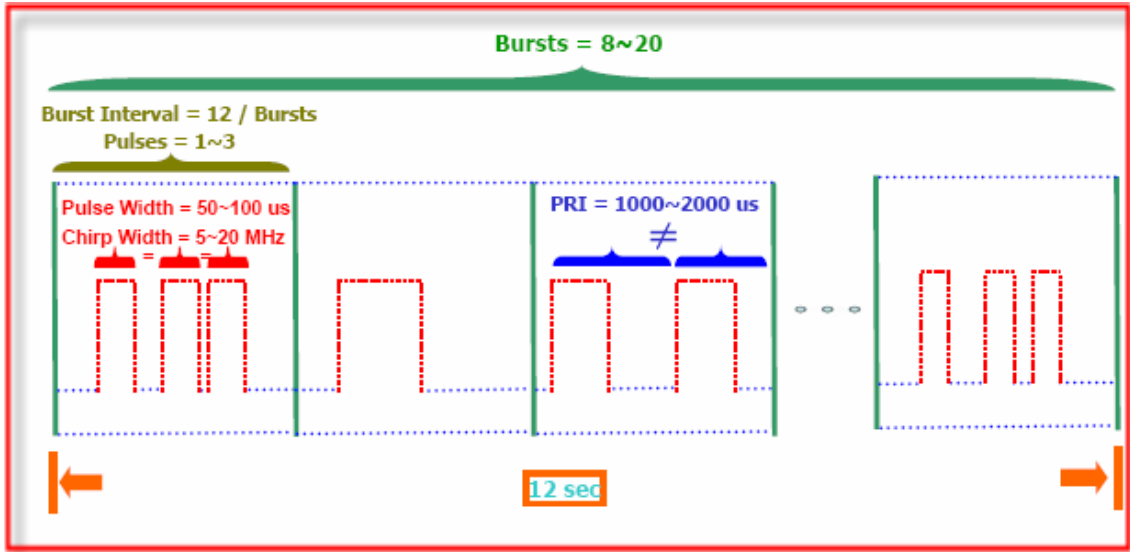

Shenzhen UnionTrust Quality and Technology Co., Ltd.

Address: 16/F, Block A, Building 6, Baoneng Science and Technology Park, Qingxiang Road No.1, Longhua New District, Shenzhen, China

Tel: +86-755-28230888

Fax: +86-755-28230886

E-mail: info@uttlab.com

<http://www.uttlab.com>

UTTR-RF-FCCPART15.407-V1.0

5.7 FREQUENCY HOPPING RADAR TEST WAVEFORM

Frequency Hopping Radar Test Waveform

Radar Type	Pulse Width (μsec)	PRI (μsec)	Pulses per Hop	Hopping Rate (kHz)	Hopping Sequence Length (msec)	Minimum Percentage of Successful Detection	Minimum Trials
6	1	333	9	0.333	300	70%	30

For the Frequency Hopping Radar Type, the same Burst parameters are used for each waveform. The hopping sequence is different for each waveform and a 100-length segment is selected from the hopping sequence defined by the following algorithm:

The first frequency in a hopping sequence is selected randomly from the group of 475 integer frequencies from 5250 – 5724 MHz. Next, the frequency that was just chosen is removed from the group and a frequency is randomly selected from the remaining 474 frequencies in the group. This process continues until all 475 frequencies are chosen for the set. For selection of a random frequency, the frequencies remaining within the group are always treated as equally likely.

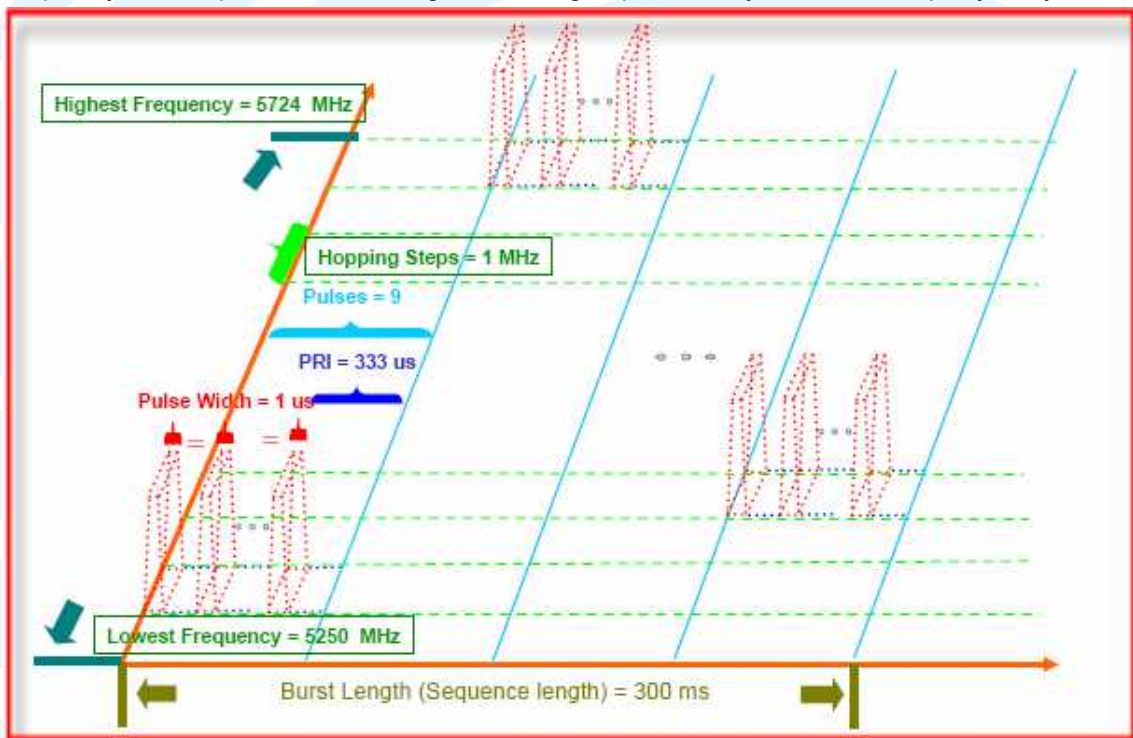

6. CALIBRATION SETUP AND DFS TEST RESULTS

6.1 CALIBRATION OF RADAR WAVEFORM

6.1.1 Radar Waveform Calibration Procedure

The Interference Radar Detection Threshold Level is -64 dBm that had been taken into account the output power range and antenna gain. The following equipment setup was used to calibrate the radiated Radar Waveform. A vector signal generator was utilized to establish the test signal level for radar type 0~6. During this process there were no transmissions by either the Master or Client Device. The spectrum analyzer was switched to the zero span (Time Domain) at the frequency of the Radar Waveform generator. Peak detection was used. The spectrum analyzer resolution bandwidth (RBW) and video bandwidth (VBW) were set to 3 MHz to measure the radar waveform. The vector signal generator amplitude was set so that the power level measured at the spectrum analyzer was -64 dBm. Capture the spectrum analyzer plots on radar waveform.

6.1.2 Conducted Calibration Setup

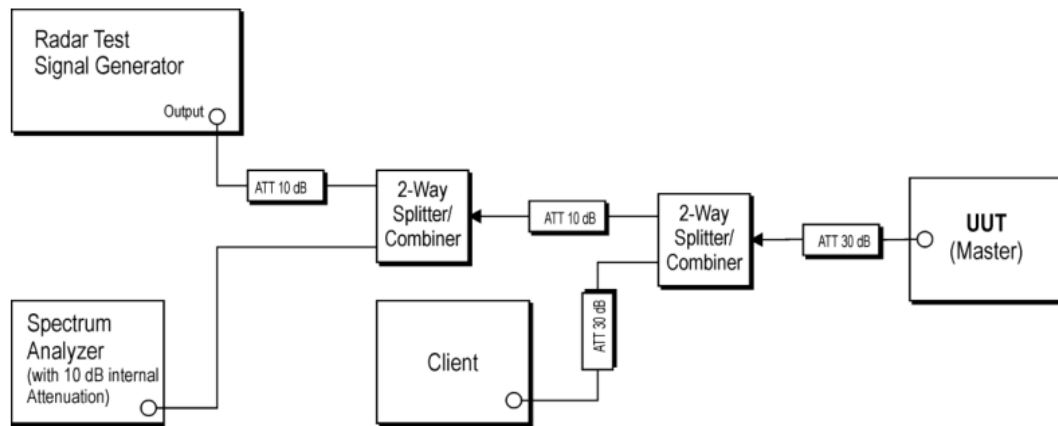

6.1.3 Calibration Deviation

There is no deviation with the original standard.

6.1.4 Radar Waveform Calibration Result

Radar Waveform calibration Plot

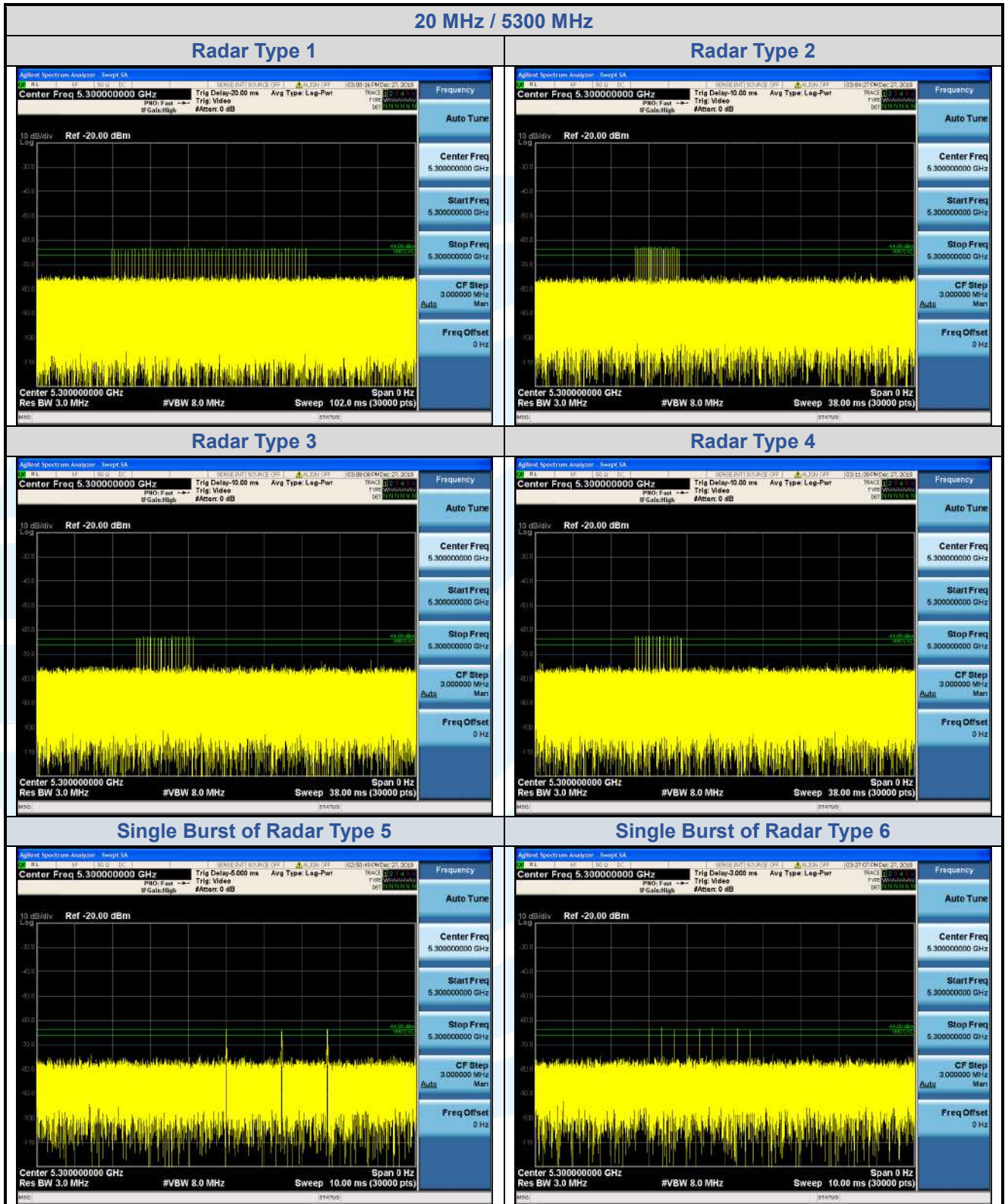

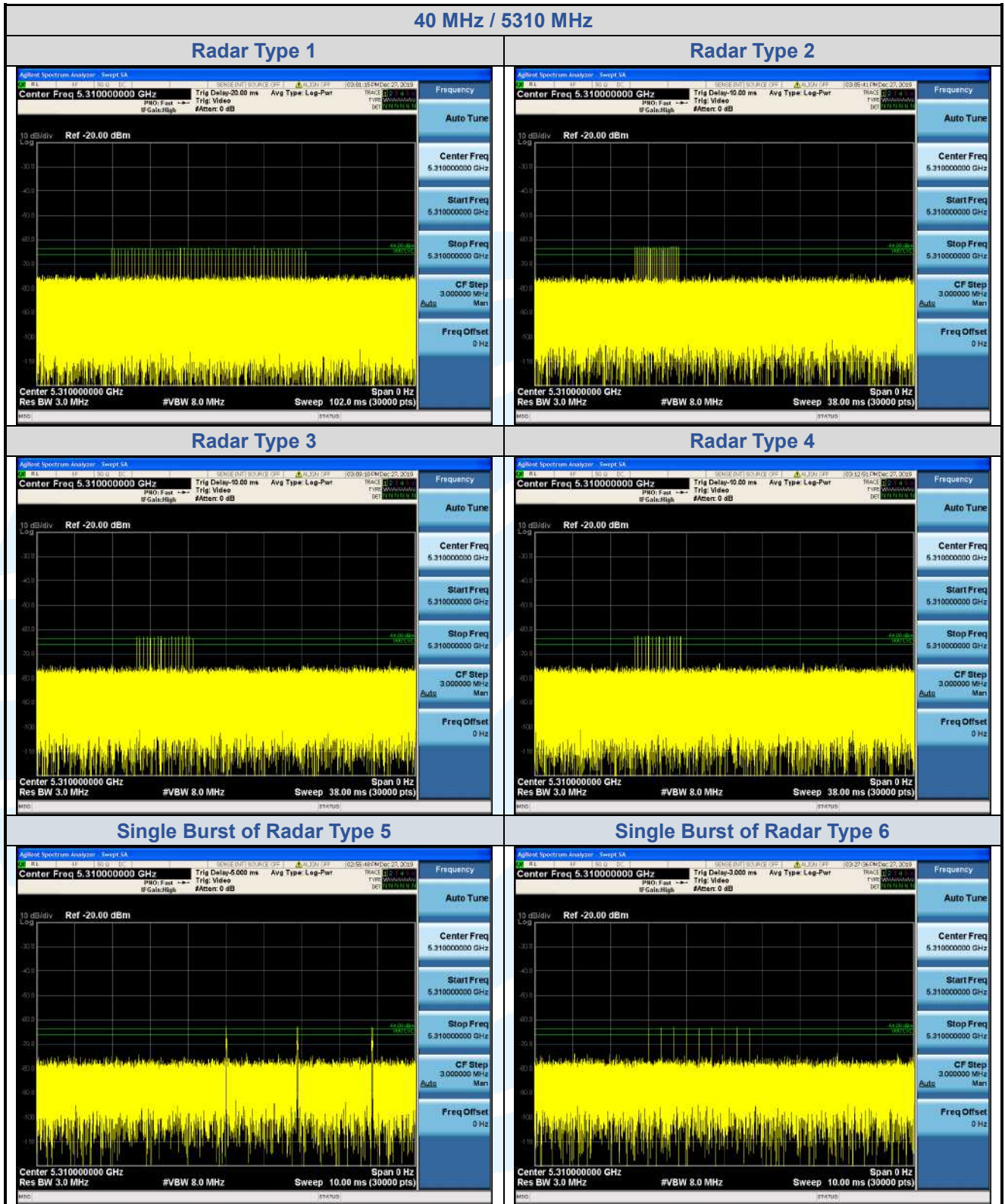

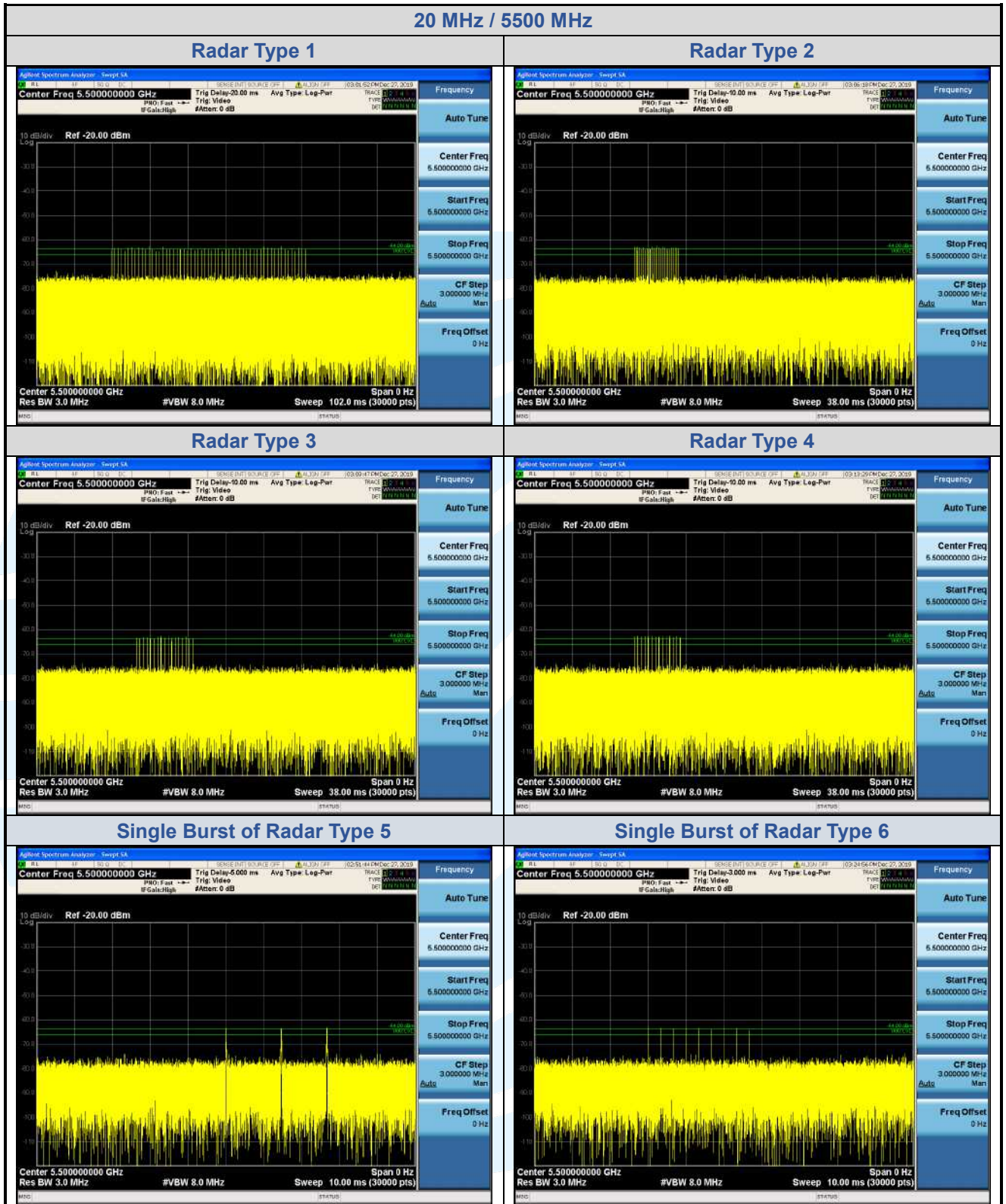

Shenzhen UnionTrust Quality and Technology Co., Ltd.

Address: 16/F, Block A, Building 6, Baoneng Science and Technology Park, Qingxiang Road No.1, Longhua New District, Shenzhen, China

Tel: +86-755-28230888

Fax: +86-755-28230886

E-mail: info@uttlab.com

<http://www.uttlab.com>

UTTR-RF-FCCPART15.407-V1.0

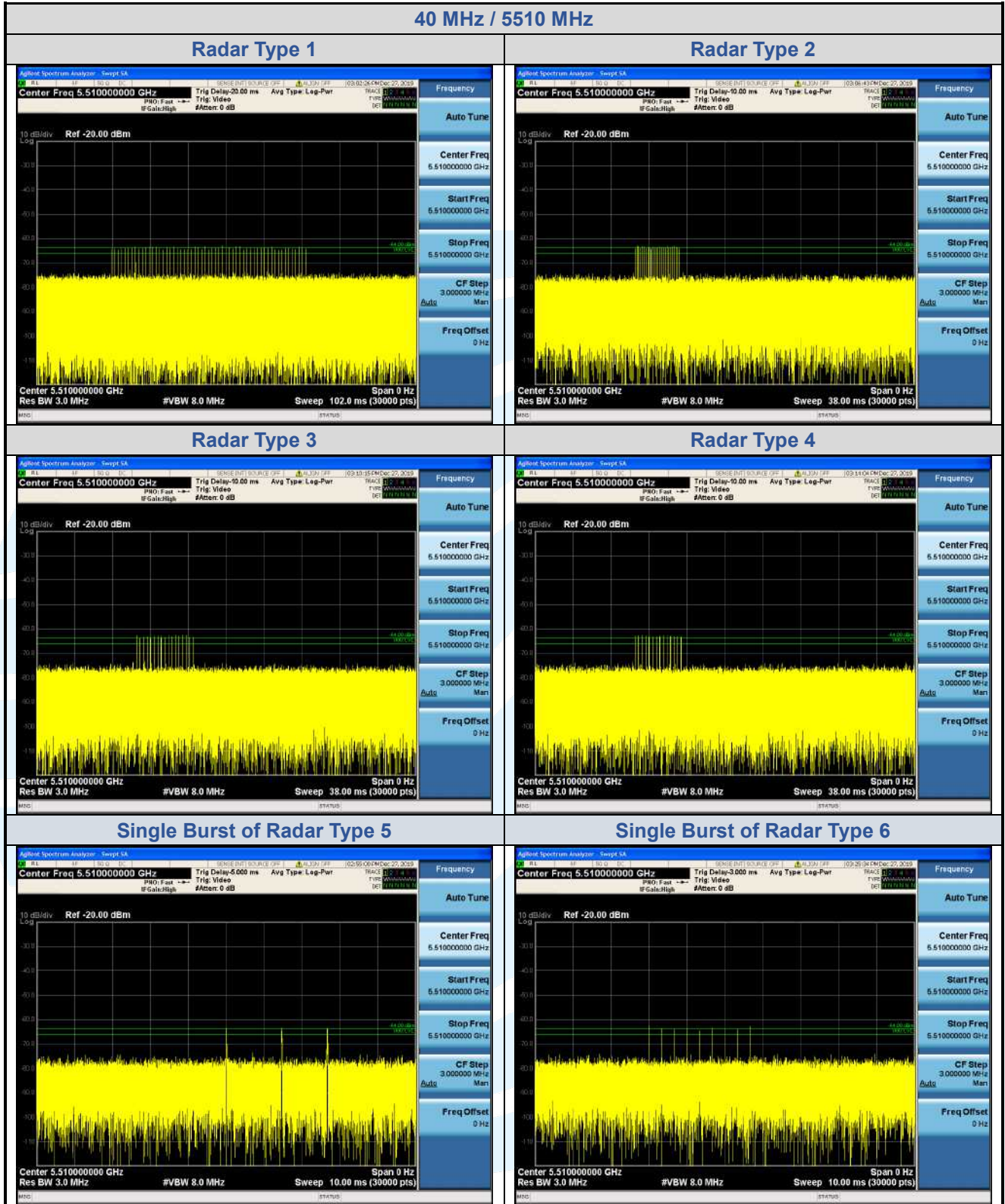

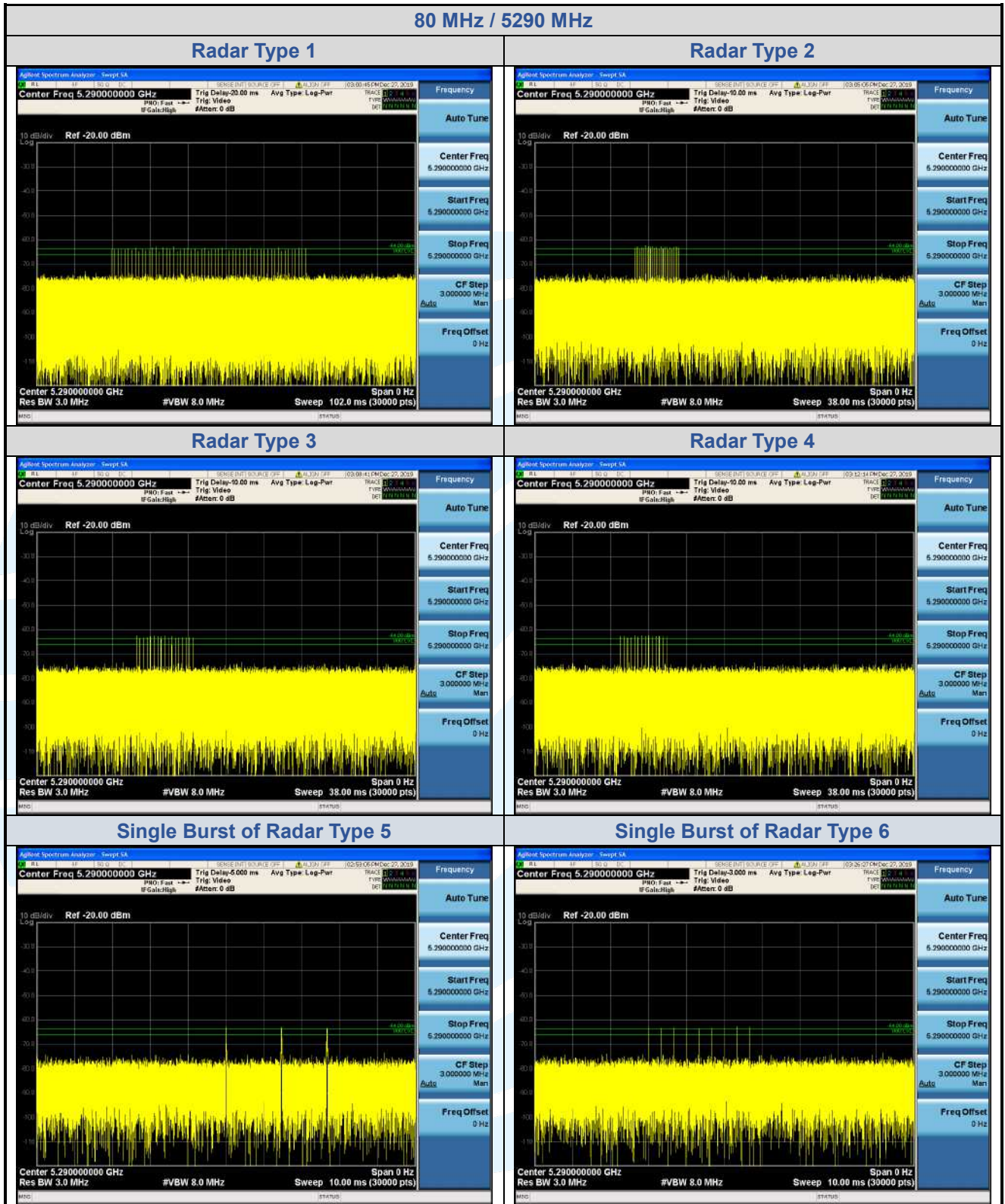

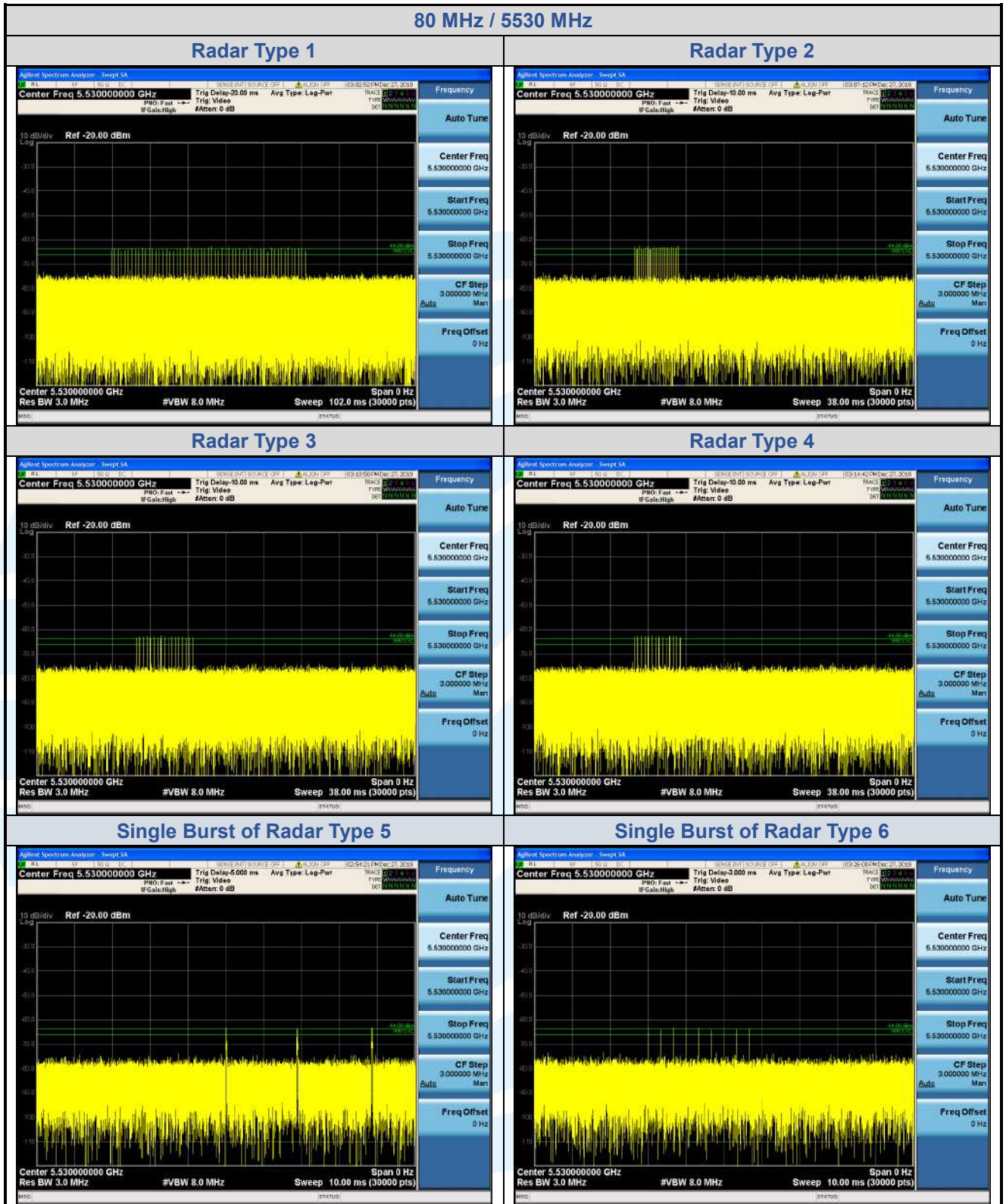

6.2 U-NII DETECTION BANDWIDTH (7.8.1)

6.2.1 Limit of U-NII Detection Bandwidth

The U-NII Detection Bandwidth shall contain minimum 100% of the 99% power bandwidth.

During the U-NII Detection Bandwidth detection test, radar type 0 is used and for each frequency step the minimum percentage of detection is 90%. Measurements are performed with no data traffic.

6.2.2 Test Procedures

- (1) Adjust the equipment to produce a single burst of the Short Pulse Radar Type 0 at the center frequency of the EUT Operating Channel at the specified DFS Detection Threshold level.
- (2) (Set the EUT up as a standalone device (no associated Client or Master, as appropriate) and no traffic. Frame based systems will be set to a talk/listen ratio of 0%/100% during this test.
- (3) Generate a single radar burst, and note the response of the EUT. Repeat for a minimum of 10 trials. The EUT must detect the Radar Waveform using the specified U-NII Detection Bandwidth criterion.
- (4) Starting at the center frequency of the EUT operating Channel, increase the radar frequency in 5 MHz steps, repeating the above test sequence, until the detection rate falls below the U-NII Detection Bandwidth criterion specified in report clause 2.3. Repeat this measurement in 1MHz steps at frequencies 5 MHz below where the detection rate begins to fall. Record the highest frequency (denote as F_H) at which detection is greater than or equal to the U-NII Detection Bandwidth criterion. Recording the detection rate at frequencies above F_H is not required to demonstrate compliance.
- (5) Starting at the center frequency of the EUT operating Channel, decrease the radar frequency in 5 MHz steps, repeating the above test sequence, until the detection rate falls below the U-NII Detection Bandwidth criterion specified in report clause 2.3. Repeat this measurement in 1MHz steps at frequencies 5 MHz above where the detection rate begins to fall. Record the lowest frequency (denote as F_L) at which detection is greater than or equal to the U-NII Detection Bandwidth criterion. Recording the detection rate at frequencies below F_L is not required to demonstrate compliance.
- (6) The U-NII Detection Bandwidth is calculated as follows:
- (7) U-NII Detection Bandwidth = $F_H - F_L$

6.2.3 Test Setup

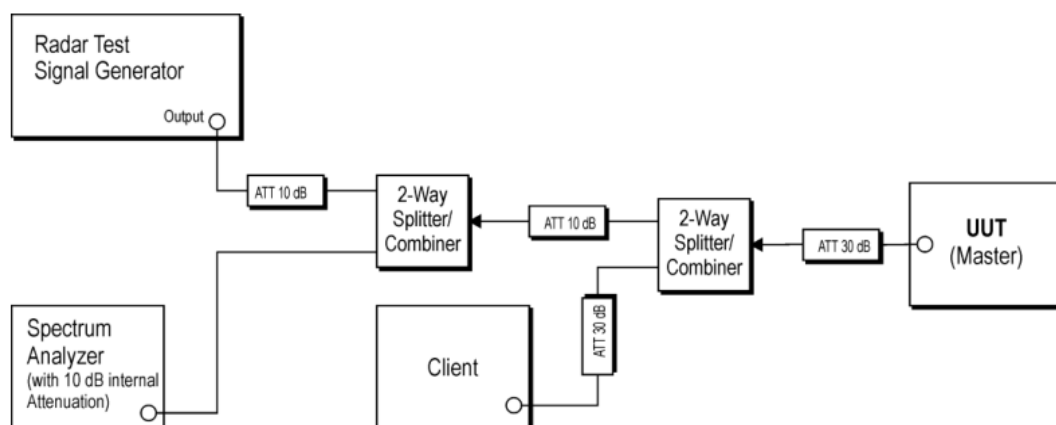

6.2.4 Test Deviation

There is no deviation with the original standard.

6.2.5 Result of U-NII Detection Bandwidth

20MHz / 5300MHz														
Frequency (MHz)	Fc	Trial Number (Detection = Y, No Detection = N)										Rate (%)	F _H /F _L	
		1	2	3	4	5	6	7	8	9	10			
5290	-10	Y	Y	Y	Y	Y	Y	Y	N	Y	Y	Y	90	
5291	-9	Y	Y	Y	Y	Y	Y	Y	Y	Y	Y	Y	100	FL
5292	-8	Y	Y	Y	Y	Y	Y	Y	Y	Y	Y	Y	100	
5293	-7	Y	Y	Y	Y	Y	Y	Y	Y	Y	Y	Y	100	
5294	-6	Y	Y	Y	Y	Y	Y	Y	Y	Y	Y	Y	100	
5295	-5	Y	Y	Y	Y	Y	Y	Y	Y	Y	Y	Y	100	
5300	0	Y	Y	Y	Y	Y	Y	Y	Y	Y	Y	Y	100	
5305	+5	Y	Y	Y	Y	Y	Y	Y	Y	Y	Y	Y	100	
5306	+6	Y	Y	Y	Y	Y	Y	Y	Y	Y	Y	Y	100	
5307	+7	Y	Y	Y	Y	Y	Y	Y	Y	Y	Y	Y	100	
5308	+8	Y	Y	Y	Y	Y	Y	Y	Y	Y	Y	Y	100	
5309	+9	Y	Y	Y	Y	Y	Y	Y	Y	Y	Y	Y	100	FH
5310	+10	Y	Y	N	Y	Y	Y	Y	Y	Y	Y	Y	90	
Detection Bandwidth = F _H – F _L = 5309 – 5291 = 18 MHz EUT 99% Bandwidth = 17.686 MHz (Refer to channel 60)														

40MHz / 5310MHz														
Frequency (MHz)	Fc	Trial Number (Detection = Y, No Detection = N)										Rate (%)	F _H /F _L	
		1	2	3	4	5	6	7	8	9	10			
5290	-20	N	N	N	N	N	N	N	N	N	N	N	0	
5291	-19	Y	N	Y	Y	Y	N	Y	Y	Y	Y	Y	80	
5292	-18	Y	Y	Y	Y	Y	Y	Y	Y	Y	Y	Y	100	FL
5293	-17	Y	Y	Y	Y	Y	Y	Y	Y	Y	Y	Y	100	
5294	-16	Y	Y	Y	Y	Y	Y	Y	Y	Y	Y	Y	100	
5295	-15	Y	Y	Y	Y	Y	Y	Y	Y	Y	Y	Y	100	
5300	-10	Y	Y	Y	Y	Y	Y	Y	Y	Y	Y	Y	100	
5305	-5	Y	Y	Y	Y	Y	Y	Y	Y	Y	Y	Y	100	
5310	0	Y	Y	Y	Y	Y	Y	Y	Y	Y	Y	Y	100	
5315	+5	Y	Y	Y	Y	Y	Y	Y	Y	Y	Y	Y	100	
5320	+10	Y	Y	Y	Y	Y	Y	Y	Y	Y	Y	Y	100	
5325	+15	Y	Y	Y	Y	Y	Y	Y	Y	Y	Y	Y	100	
5326	+16	Y	Y	Y	Y	Y	Y	Y	Y	Y	Y	Y	100	
5327	+17	Y	Y	Y	Y	Y	Y	Y	Y	Y	Y	Y	100	
5328	+18	Y	Y	Y	Y	Y	Y	Y	Y	Y	Y	Y	100	FH
5329	+19	Y	Y	Y	Y	Y	Y	N	Y	Y	Y	Y	90	
5330	+20	N	N	N	N	N	N	N	N	N	N	N	0	
Detection Bandwidth = F _H – F _L = 5328 – 5292 = 36 MHz EUT 99% Bandwidth = 36.039 MHz (Refer to channel 62)														

20MHz / 5500MHz													
Frequency (MHz)	Fc	Trial Number (Detection = Y, No Detection = N)										Rate (%)	F _H /F _L
		1	2	3	4	5	6	7	8	9	10		
5490	-10	Y	Y	Y	Y	N	Y	Y	Y	Y	Y	90	
5491	-9	Y	Y	Y	Y	Y	Y	Y	Y	Y	Y	100	FL
5492	-8	Y	Y	Y	Y	Y	Y	Y	Y	Y	Y	100	
5493	-7	Y	Y	Y	Y	Y	Y	Y	Y	Y	Y	100	
5494	-6	Y	Y	Y	Y	Y	Y	Y	Y	Y	Y	100	
5495	-5	Y	Y	Y	Y	Y	Y	Y	Y	Y	Y	100	
5500	0	Y	Y	Y	Y	Y	Y	Y	Y	Y	Y	100	
5505	+5	Y	Y	Y	Y	Y	Y	Y	Y	Y	Y	100	
5506	+6	Y	Y	Y	Y	Y	Y	Y	Y	Y	Y	100	
5507	+7	Y	Y	Y	Y	Y	Y	Y	Y	Y	Y	100	
5508	+8	Y	Y	Y	Y	Y	Y	Y	Y	Y	Y	100	
5509	+9	Y	Y	Y	Y	Y	Y	Y	Y	Y	Y	100	FH
5510	+10	Y	Y	Y	Y	Y	Y	N	Y	Y	Y	90	
Detection Bandwidth = F _H – F _L = 5509 – 5491 = 18 MHz EUT 99% Bandwidth = 17.684 MHz (Refer to channel 100)													

40MHz / 5310MHz													
Frequency (MHz)	Fc	Trial Number (Detection = Y, No Detection = N)										Rate (%)	F _H /F _L
		1	2	3	4	5	6	7	8	9	10		
5490	-20	N	Y	Y	N	Y	Y	Y	Y	Y	Y	80	
5491	-19	Y	Y	Y	Y	Y	Y	Y	Y	Y	Y	100	
5492	-18	Y	Y	Y	Y	Y	Y	Y	Y	Y	Y	100	FL
5493	-17	Y	Y	Y	Y	Y	Y	Y	Y	Y	Y	100	
5494	-16	Y	Y	Y	Y	Y	Y	Y	Y	Y	Y	100	
5495	-15	Y	Y	Y	Y	Y	Y	Y	Y	Y	Y	100	
5500	-10	Y	Y	Y	Y	Y	Y	Y	Y	Y	Y	100	
5505	-5	Y	Y	Y	Y	Y	Y	Y	Y	Y	Y	100	
5510	0	Y	Y	Y	Y	Y	Y	Y	Y	Y	Y	100	
5515	+5	Y	Y	Y	Y	Y	Y	Y	Y	Y	Y	100	
5520	+10	Y	Y	Y	Y	Y	Y	Y	Y	Y	Y	100	
5525	+15	Y	Y	Y	Y	Y	Y	Y	Y	Y	Y	100	
5526	+16	Y	Y	Y	Y	Y	Y	Y	Y	Y	Y	100	
5527	+17	Y	Y	Y	Y	Y	Y	Y	Y	Y	Y	100	
5528	+18	Y	Y	Y	Y	Y	Y	Y	Y	Y	Y	100	
5529	+19	Y	Y	Y	Y	Y	Y	Y	Y	Y	Y	100	FH
5530	+20	Y	N	Y	N	Y	Y	Y	Y	N	Y	70	
Detection Bandwidth = F _H – F _L = 5529 – 5492 = 37 MHz EUT 99% Bandwidth = 36.110 MHz (Refer to channel 102)													

Shenzhen UnionTrust Quality and Technology Co., Ltd.

Address: 16/F, Block A, Building 6, Baoneng Science and Technology Park, Qingxiang Road No.1, Longhua New District, Shenzhen, China

Tel: +86-755-28230888

Fax: +86-755-28230886

E-mail: info@uttlab.com

<http://www.uttlab.com>

UTTR-RF-FCCPART15.407-V1.0

80MHz / 5290MHz													
Frequency (MHz)	Fc	Trial Number (Detection = Y, No Detection = N)										Rate (%)	F _H /F _L
		1	2	3	4	5	6	7	8	9	10		
5250	-40	N	Y	Y	N	Y	Y	Y	Y	Y	Y	80	
5251	-39	Y	Y	Y	Y	Y	Y	Y	Y	Y	Y	100	FL
5252	-38	Y	Y	Y	Y	Y	Y	Y	Y	Y	Y	100	
5253	-37	Y	Y	Y	Y	Y	Y	Y	Y	Y	Y	100	
5254	-36	Y	Y	Y	Y	Y	Y	Y	Y	Y	Y	100	
5255	-35	Y	Y	Y	Y	Y	Y	Y	Y	Y	Y	100	
5260	-30	Y	Y	Y	Y	Y	Y	Y	Y	Y	Y	100	
5265	-25	Y	Y	Y	Y	Y	Y	Y	Y	Y	Y	100	
5270	-20	Y	Y	Y	Y	Y	Y	Y	Y	Y	Y	100	
5275	-15	Y	Y	Y	Y	Y	Y	Y	Y	Y	Y	100	
5280	-10	Y	Y	Y	Y	Y	Y	Y	Y	Y	Y	100	
5290	0	Y	Y	Y	Y	Y	Y	Y	Y	Y	Y	100	
5300	+10	Y	Y	Y	Y	Y	Y	Y	Y	Y	Y	100	
5305	+15	Y	Y	Y	Y	Y	Y	Y	Y	Y	Y	100	
5310	+20	Y	Y	Y	Y	Y	Y	Y	Y	Y	Y	100	
5315	+25	Y	Y	Y	Y	Y	Y	Y	Y	Y	Y	100	
5320	+30	Y	Y	Y	Y	Y	Y	Y	Y	Y	Y	100	
5325	+35	Y	Y	Y	Y	Y	Y	Y	Y	Y	Y	100	
5326	+36	Y	Y	Y	Y	Y	Y	Y	Y	Y	Y	100	
5327	+37	Y	Y	Y	Y	Y	Y	Y	Y	Y	Y	100	
5328	+38	Y	Y	Y	Y	Y	Y	Y	Y	Y	Y	100	FH
5329	+39	Y	Y	N	Y	Y	Y	N	Y	Y	Y	80	
5330	+40	Y	N	N	Y	N	Y	N	Y	N	Y	50	
Detection Bandwidth = F _H – F _L = 5328 – 5251 = 77 MHz EUT 99% Bandwidth = 74.972 MHz (Refer to channel 58)													

80MHz / 5530MHz													
Frequency (MHz)	Fc	Trial Number (Detection = Y, No Detection = N)										Rate (%)	F _H /F _L
		1	2	3	4	5	6	7	8	9	10		
5490	-40	N	Y	Y	N	Y	Y	Y	Y	Y	Y	80	
5491	-39	Y	Y	Y	Y	Y	Y	Y	Y	Y	Y	100	FL
5492	-38	Y	Y	Y	Y	Y	Y	Y	Y	Y	Y	100	
5493	-37	Y	Y	Y	Y	Y	Y	Y	Y	Y	Y	100	
5494	-36	Y	Y	Y	Y	Y	Y	Y	Y	Y	Y	100	
5495	-35	Y	Y	Y	Y	Y	Y	Y	Y	Y	Y	100	
5500	-30	Y	Y	Y	Y	Y	Y	Y	Y	Y	Y	100	
5505	-25	Y	Y	Y	Y	Y	Y	Y	Y	Y	Y	100	
5510	-20	Y	Y	Y	Y	Y	Y	Y	Y	Y	Y	100	
5515	-15	Y	Y	Y	Y	Y	Y	Y	Y	Y	Y	100	
5520	-10	Y	Y	Y	Y	Y	Y	Y	Y	Y	Y	100	
5530	0	Y	Y	Y	Y	Y	Y	Y	Y	Y	Y	100	
5540	+10	Y	Y	Y	Y	Y	Y	Y	Y	Y	Y	100	
5545	+15	Y	Y	Y	Y	Y	Y	Y	Y	Y	Y	100	
5550	+20	Y	Y	Y	Y	Y	Y	Y	Y	Y	Y	100	
5555	+25	Y	Y	Y	Y	Y	Y	Y	Y	Y	Y	100	
5560	+30	Y	Y	Y	Y	Y	Y	Y	Y	Y	Y	100	
5565	+35	Y	Y	Y	Y	Y	Y	Y	Y	Y	Y	100	
5566	+36	Y	Y	Y	Y	Y	Y	Y	Y	Y	Y	100	
5567	+37	Y	Y	Y	Y	Y	Y	Y	Y	Y	Y	100	
5568	+38	Y	Y	Y	Y	Y	Y	Y	Y	Y	Y	100	FH
5569	+39	Y	Y	N	Y	Y	Y	N	Y	Y	Y	80	
5570	+40	Y	N	N	Y	N	Y	N	Y	N	Y	50	
Detection Bandwidth = F _H – F _L = 5568 – 5491 = 77 MHz EUT 99% Bandwidth = 75.073 MHz (Refer to channel 106)													

6.3 CHANNEL AVAILABILITY CHECK (7.8.2)

6.3.1 Limit of Channel Availability Check

The Initial Channel Availability Check Time tests that the EUT does not emit beacon, control, or data signals on the test Channel until the power-up sequence has been completed and the U-NII device checks for radar waveforms for one minute on the test Channel.

6.3.2 Test Procedures

6.3.2.1 Initial Channel Availability Check Time

This test does not use any radar waveforms and only needs to be performed one time.

- (1) The U-NII devices will be powered on and be instructed to operate on the appropriate U-NII Channel that must incorporate DFS functions. At the same time the EUT is powered on, the spectrum analyzer will be set to zero span mode with a 3 MHz RBW and 3 MHz VBW on the Channel occupied by the radar (Chr) with a 2.5 minute sweep time. The spectrum analyzer's sweep will be started at the same time power is applied to the U-NII device.
- (2) The EUT should not transmit any beacon or data transmissions until at least 1 minute after the completion of the power-on cycle.

6.3.2.2 Radar Burst at the Beginning of the Channel Availability Check Time

The steps below define the procedure to verify successful radar detection on the test Channel during a period equal to the Channel Availability Check Time and avoidance of operation on that Channel when a radar Burst with a level equal to the DFS Detection Threshold + 1 dB occurs at the beginning of the Channel Availability Check Time. This is illustrated in Figure 15.

- (1) The Radar Waveform generator and EUT are connected using the applicable test setup and the power of the EUT is switched off.
- (2) The EUT is powered on at T0. T1 denotes the instant when the EUT has completed its power-up sequence (T_{power_up}). The Channel Availability Check Time commences on Chr at instant T1 and will end no sooner than T1 + T_{ch_avail_check}.
- (3) A single Burst of one of the Short Pulse Radar Types 1-4 will commence within a 6 second window starting at T1. An additional 1 dB is added to the radar test signal to ensure it is at or above the DFS Detection Threshold, accounting for equipment variations/errors.
- (4) Visual indication or measured results on the EUT of successful detection of the radar Burst will be recorded and reported. Observation of Chr for EUT emissions will continue for 2.5 minutes after the radar Burst has been generated.
- (5) Verify that during the 2.5 minute measurement window no EUT transmissions occurred on Chr. The Channel Availability Check results will be recorded.

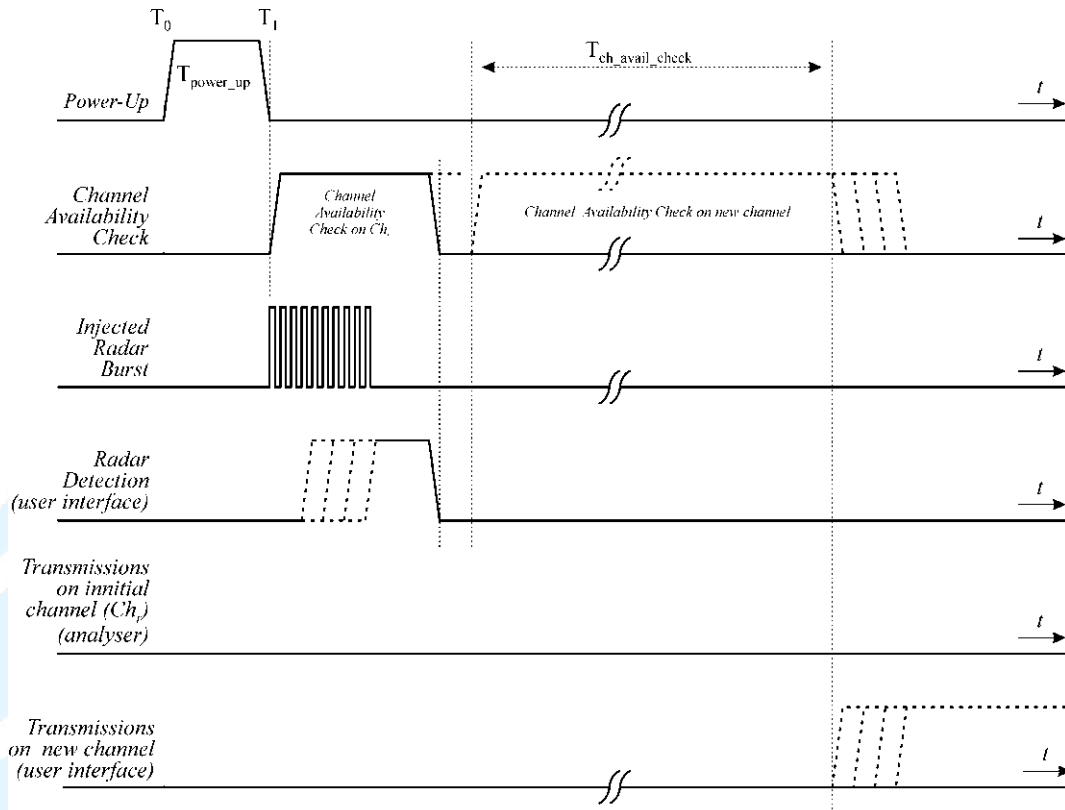

Figure 15: Example of timing for radar testing at the beginning of the Channel Availability Check Time

6.3.2.3 Radar Burst at the End of the Channel Availability Check Time

The steps below define the procedure to verify successful radar detection on the test Channel during a period equal to the Channel Availability Check Time and avoidance of operation on that Channel when a radar Burst with a level equal to the DFS Detection Threshold + 1dB occurs at the end of the Channel Availability Check Time. This is illustrated in Figure 16.

- (1) The Radar Waveform generator and EUT are connected using the applicable test setup and the power of the EUT is switched off.
- (2) The EUT is powered on at T0. T1 denotes the instant when the EUT has completed its power-up sequence (Tpower_up). The Channel Availability Check Time commences on Chr at instant T1 and will end no sooner than T1 + Tch_avail_check.
- (3) A single Burst of one of the Short Pulse Radar Types 1-4 will commence within a 6 second window starting at T1 + 54 seconds. An additional 1 dB is added to the radar test signal to ensure it is at or above the DFS Detection Threshold, accounting for equipment variations/errors.
- (4) Visual indication or measured results on the EUT of successful detection of the radar Burst will be recorded and reported. Observation of Chr for EUT emissions will continue for 2.5 minutes after the radar Burst has been generated.
- (5) Verify that during the 2.5 minute measurement window no EUT transmissions occurred on Chr. The Channel Availability Check results will be recorded.

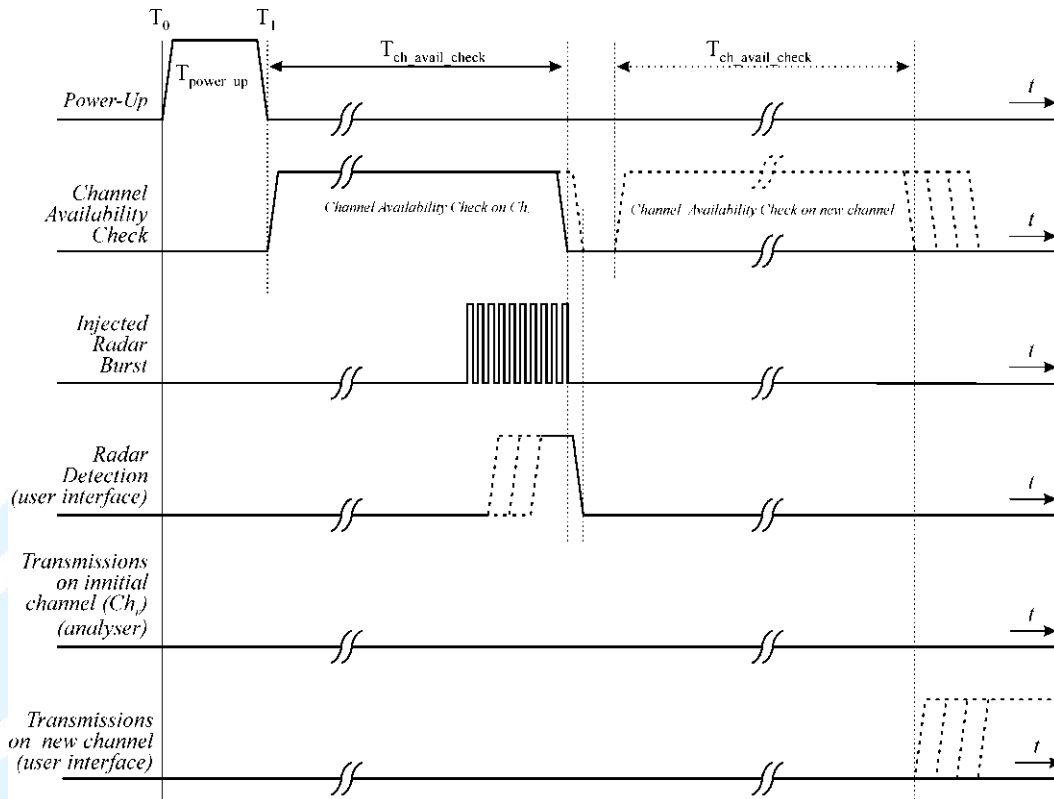
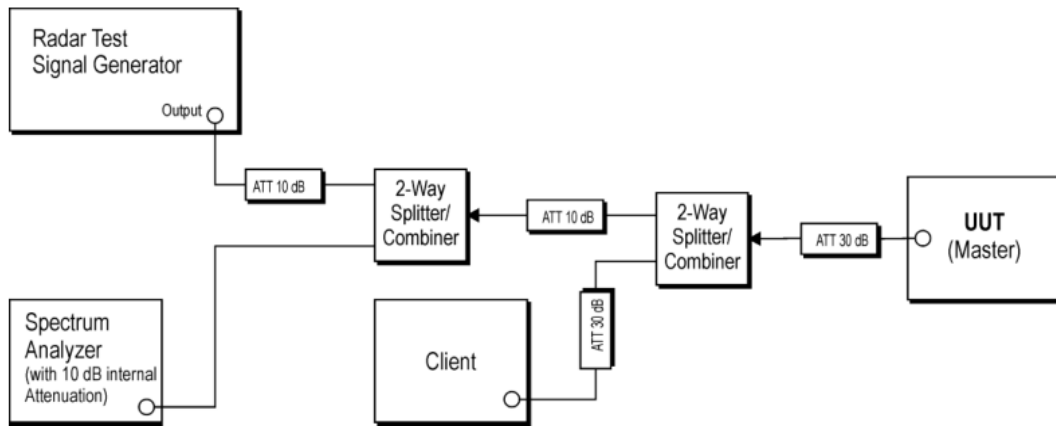

Figure 16: Example of timing for radar testing towards the end of the Channel Availability Check Time

6.3.3 Test Setup



6.3.4 Test Deviation

There is no deviation with the original standard.

6.3.5 Result of Channel Availability Check Time

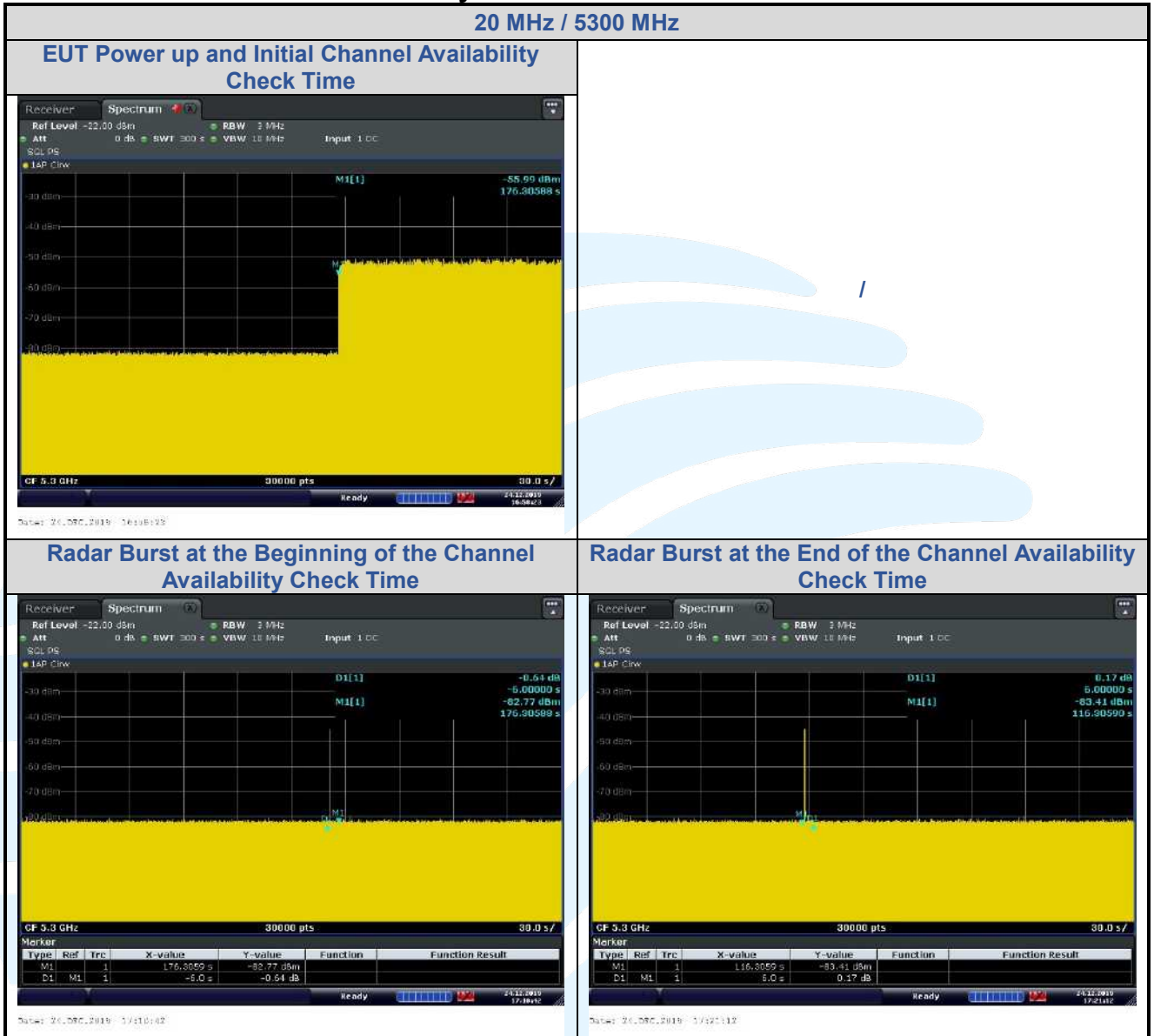

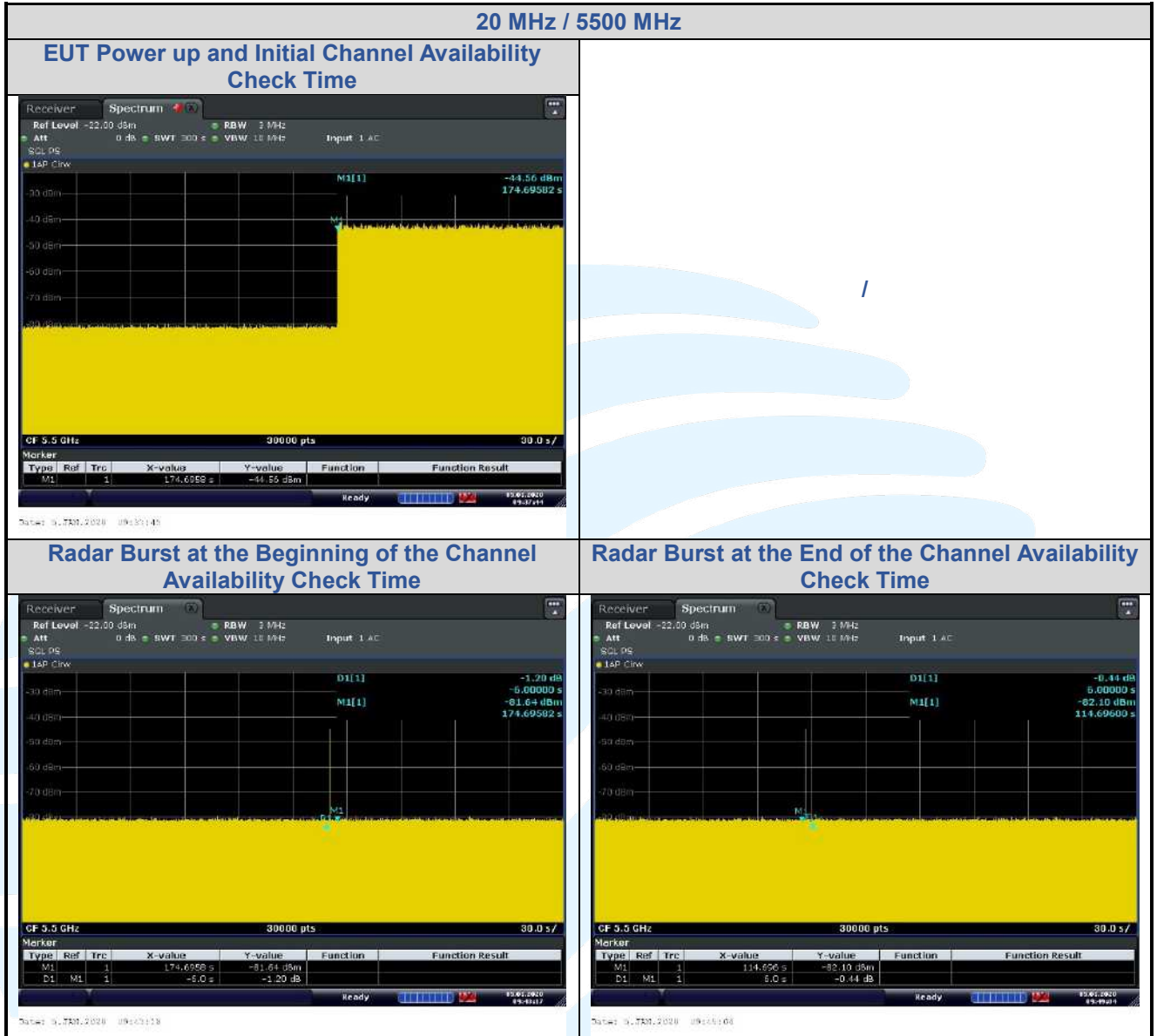

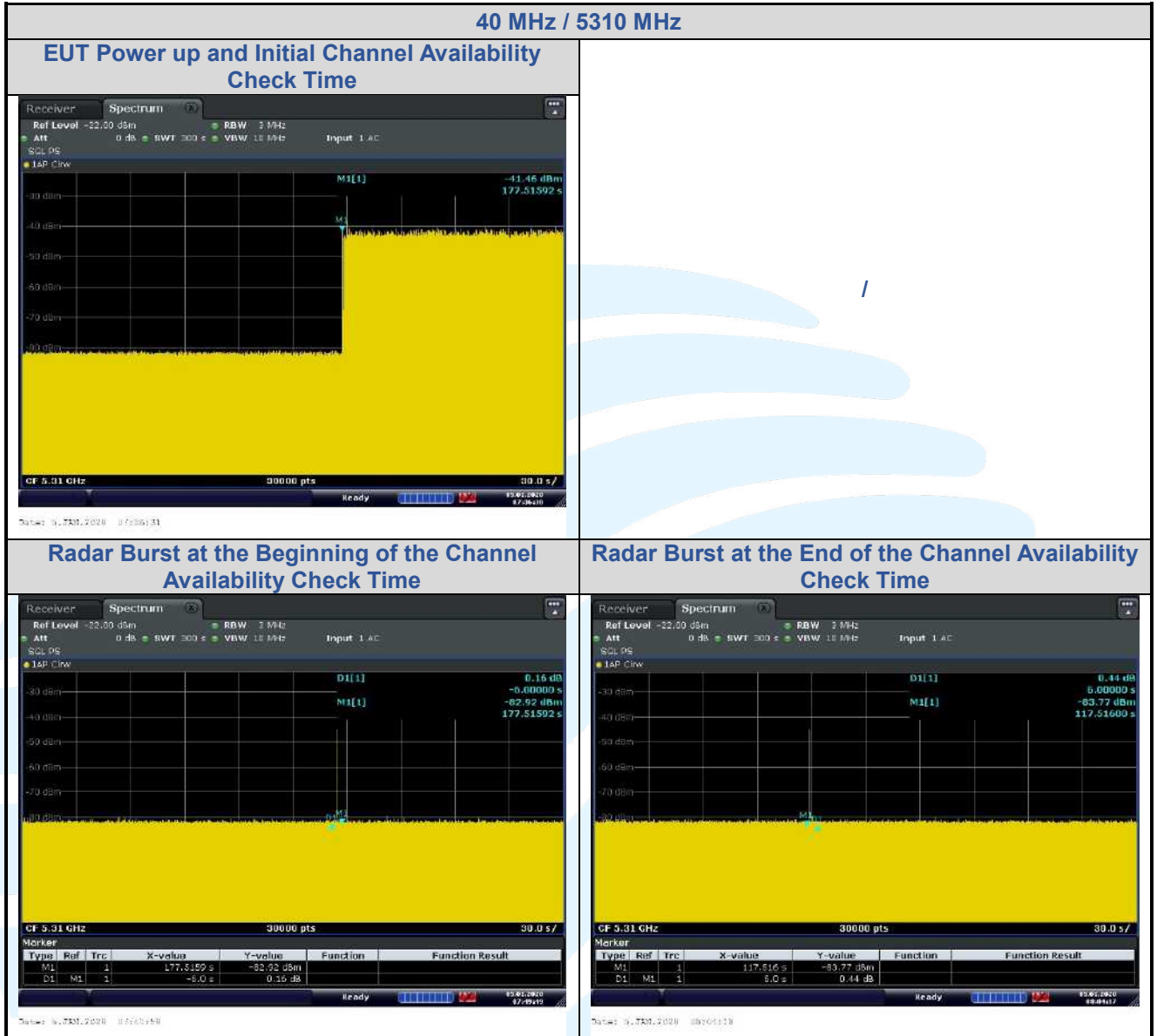

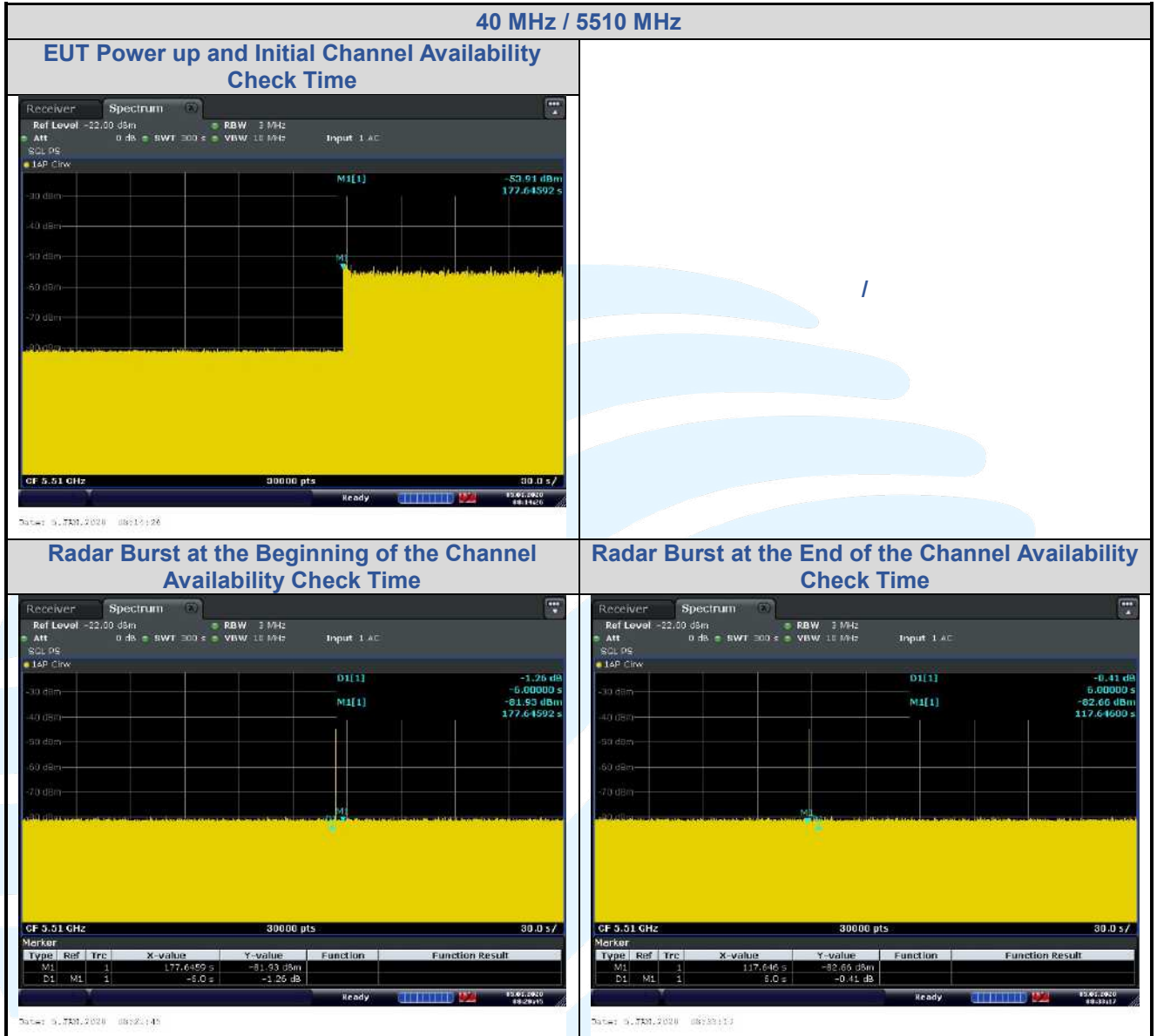



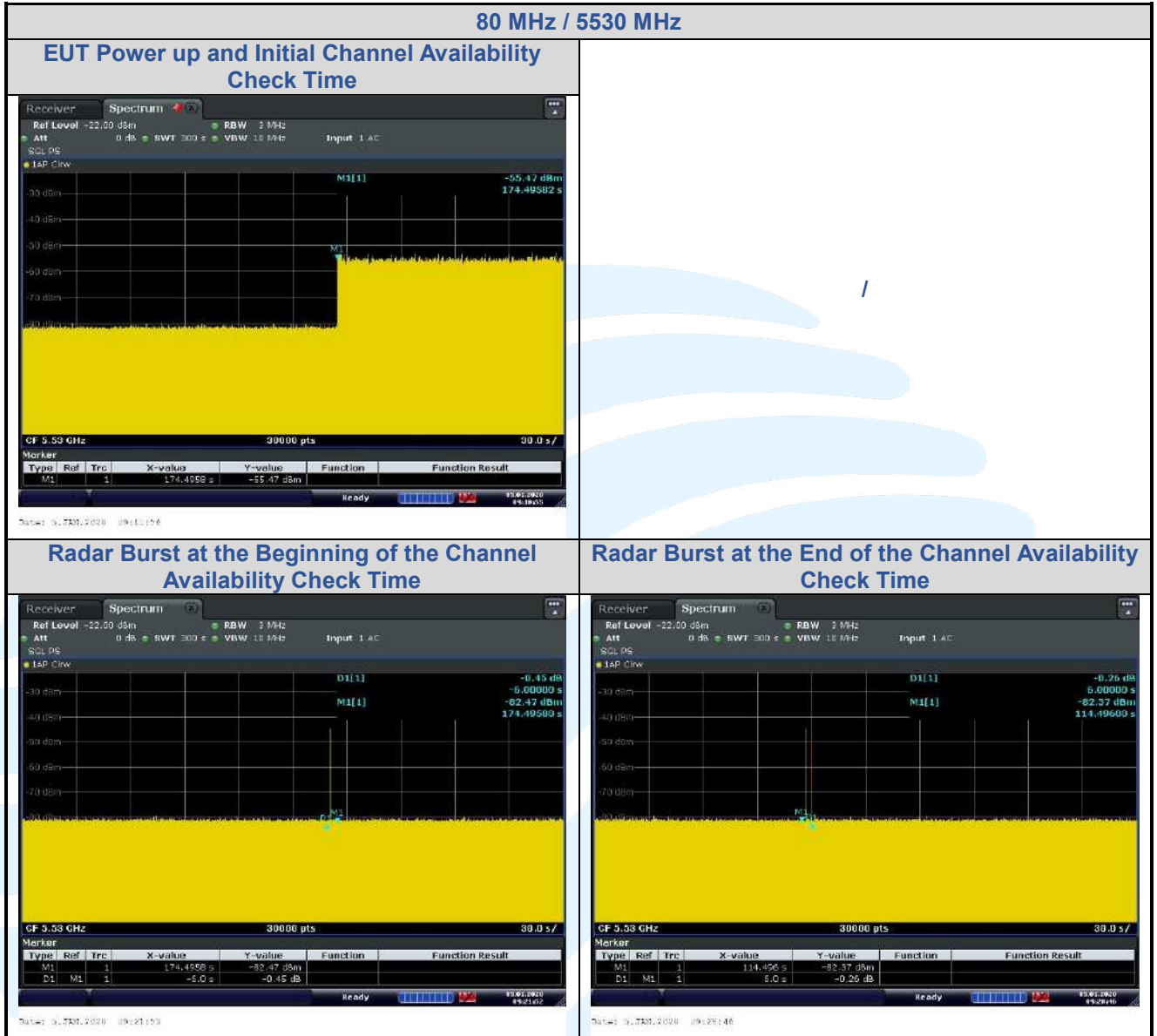

6.4 IN-SERVICE MONITORING: CHANNEL MOVE TIME, CHANNEL CLOSING TRANSMISSION TIME AND NON-OCCUPANCY PERIOD (7.8.3)

6.4.1 Limit of In-Service Monitoring

The EUT has In-Service Monitoring function to continuously monitor the radar signals, If radar is detected, it must leave the channel (Shutdown). The Channel Move Time to cease all transmissions on the current Channel upon detection of a Radar Waveform above the DFS Detection Threshold within 10 sec. The total duration of Channel Closing Transmission Time is comprised of 200 milliseconds starting at the beginning of the Channel Move Time plus any additional intermittent control signals required to facilitate Channel changes (an aggregate of 60 milliseconds) during the remainder of the 10 second period. The aggregate duration of control signals will not count quiet periods in between transmissions.

Non-Occupancy Period time is 30 minute during which a Channel will not be utilized after a Radar Waveform is detected on that Channel.

6.4.2 Test Procedures

- (1) One frequency will be chosen from the Operating Channels of the EUT within the 5250-5350 MHz or 5470-5725 MHz bands. For 802.11 devices, the test frequency must contain control signals. This can be verified by disabling channel loading and monitoring the spectrum analyzer. If no control signals are detected, another frequency must be selected within the emission bandwidth where control signals are detected.
- (2) In case the EUT is a Master Device, a U-NII device operating as a Client Device will be used and it is assumed that the Client will associate with the EUT (Master). For radiated tests, the emissions of the Radar Waveform generator will be directed towards the Master Device. If the Master Device has antenna gain, the main beam of the antenna will be directed toward the radar emitter. Vertical polarization is used for testing.
- (3) The TCP protocol unicast data stream was generated by the iperf software command line with at least 17% activity ratio over any 100ms period.
- (4) Timing plots are reported with calculations demonstrating a minimum channel loading of approximately 17% or greater. For example, channel loading can be estimated by setting the spectrum analyzer for zero span and approximate the Time On/ (Time On + Off Time).
- (5) At time T₀ the Radar Waveform generator sends a Burst of pulses for one of the Short Pulse Radar Types 1-4 at DFS Detection Threshold levels on the Operating Channel. An additional 1 dB is added to the radar test signal to ensure it is at or above the DFS Detection Threshold, accounting for equipment variations/errors.
- (6) Observe the transmissions of the EUT at the end of the radar Burst on the Operating Channel for duration greater than 10 seconds. Measure and record the transmissions from the EUT during the observation time (Channel Move Time). Measure and record the Channel Move Time and Channel Closing Transmission Time if radar detection occurs.
- (7) (7) When operating as a Master Device, monitor the EUT for more than 30 minutes following instant T₂ to verify that the EUT does not resume any transmissions on this Channel. Perform this test once and record the measurement result.

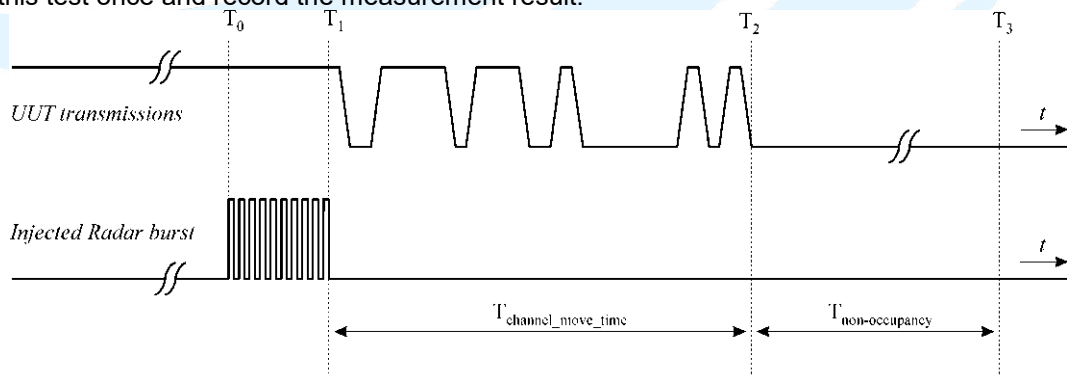

- (8) One 12 seconds plot is reported for the Short Pulse Radar Type 0
- (9) Measurement of the aggregate duration of the Channel Closing Transmission Time method. With the spectrum analyzer set to zero span tuned to the center frequency of the EUT operating channel at the radar simulated frequency, peak detection, and max hold, the dwell time per bin is given by: Dwell (0.3ms) = S (12000ms) / B (40000); where Dwell is the dwell time per

spectrum analyzer sampling bin, S is the sweep time and B is the number of spectrum analyzer sampling bins. An upper bound of the aggregate duration of the intermittent control signals of Channel Closing Transmission Time is calculated by: $C (ms) = N \times Dwell (0.3 ms)$; where C is the Closing Time, N is the number of spectrum analyzer sampling bins (intermittent control signals) showing a U-NII transmission and Dwell is the dwell time per bin.

6.4.3 Test Setup

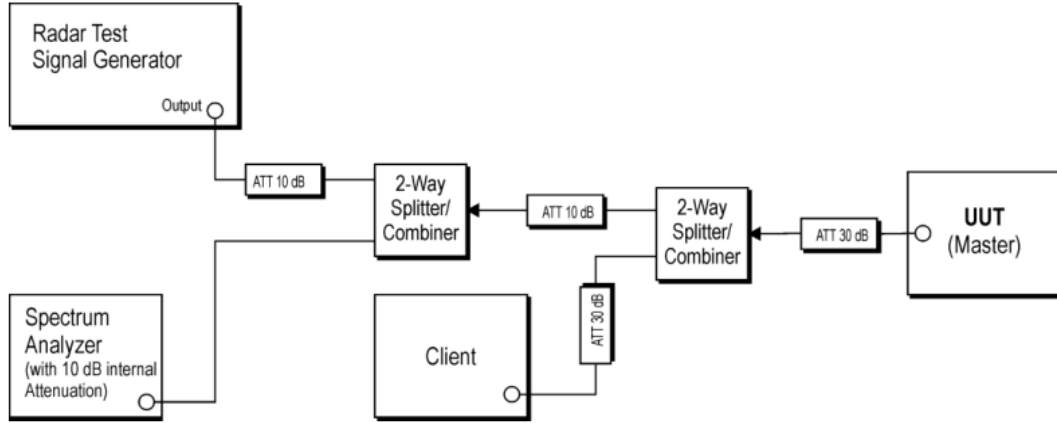

6.4.4 Test Deviation

There is no deviation with the original standard.

6.4.5 Result of Channel Move Time, Channel Closing Transmission Time and Non-Occupancy Period for Client Beacon Test

Test Mode :	Master	Temperature :	24.5°C
Test Engineer :	Hank Wu	Relative Humidity :	49%

Test Item	Test Result		Limit	PASS/FAIL
	80 MHz 5290 MHz	80 MHz 5530 MHz		
Channel Move Time	0.657 s	0.597 s	< 10s	PASS
Channel Closing Transmission Time	200ms + 10.2 ms	200ms + 16.2 ms	< 260ms	PASS
Non-Occupancy Period	≥ 30 min	≥ 30 min	≥ 30 min	PASS

Note: The Channel Closing Transmission Time is comprised of 200 milliseconds starting at the beginning of the Channel Move Time plus any additional intermittent control signals required to facilitate a Channel move (an aggregate of 60 milliseconds) during the remainder of the 10 seconds period. The aggregate duration of control signals will not count quiet periods in between transmissions.

6.4.6 Channel Move Time, Channel Closing Transmission Time and Non-Occupancy Period Test Plots

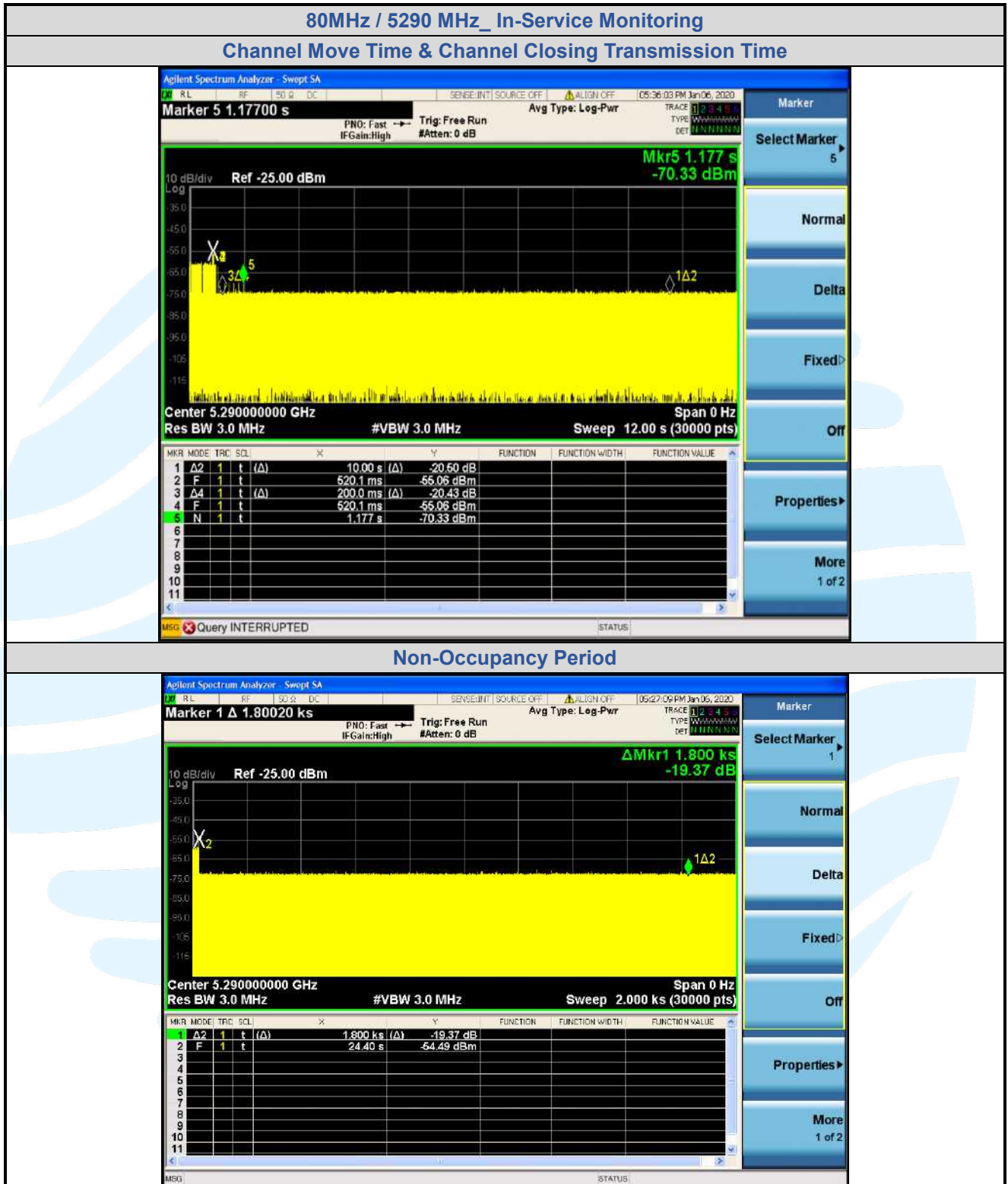

Note:
 Dwell (0.3 ms)= Sweep Time (12000 ms) / Sweep Point Bins (40000)
 Channel Closing Transmission Time (200 + 10.2ms) = 200 + Number (34) X Dwell (0.3 ms) < 260ms

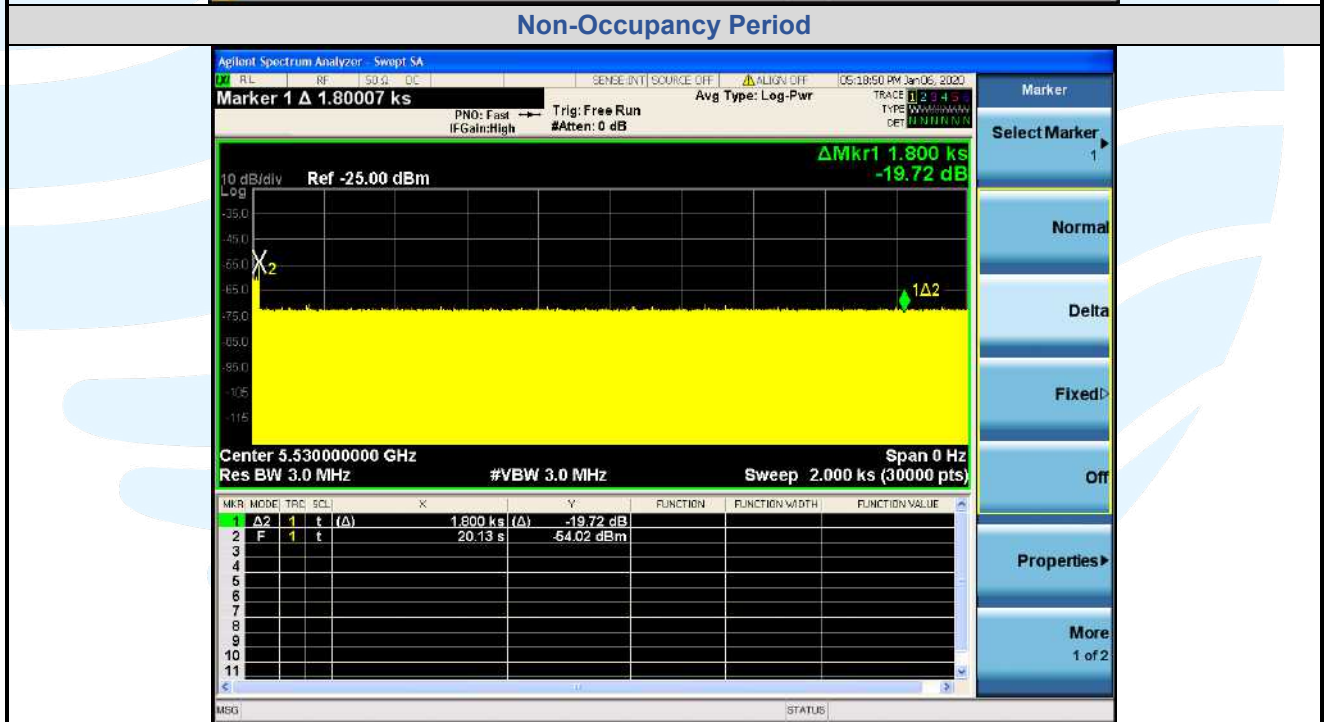
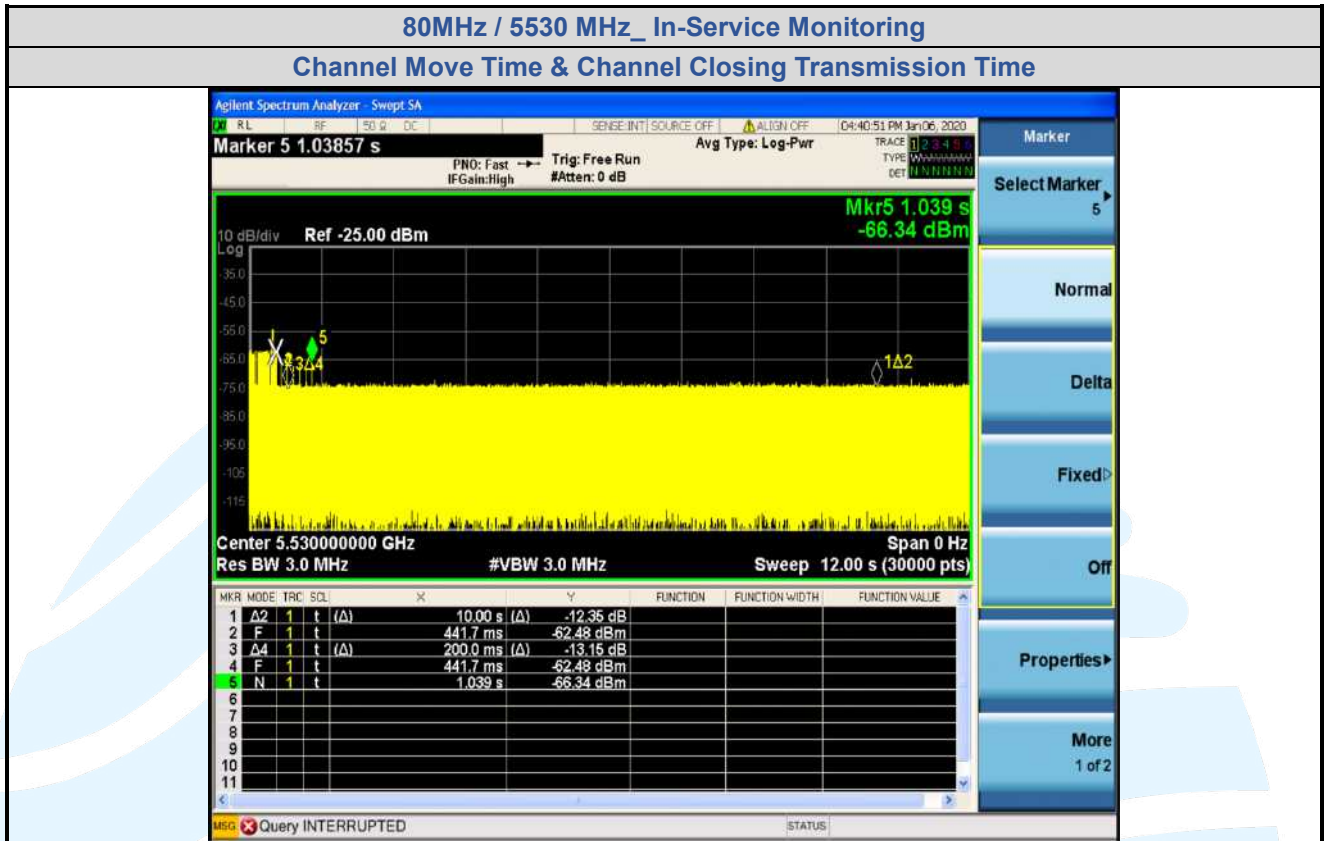

Note:
 Dwell (0.3 ms)= Sweep Time (12000 ms) / Sweep Point Bins (40000)
 Channel Closing Transmission Time (200 +16.2ms) = 200 + Number (54) X Dwell (0.3 ms) < 260ms

6.4.7 Data Traffic Channel Loading and Noise Floor Plots

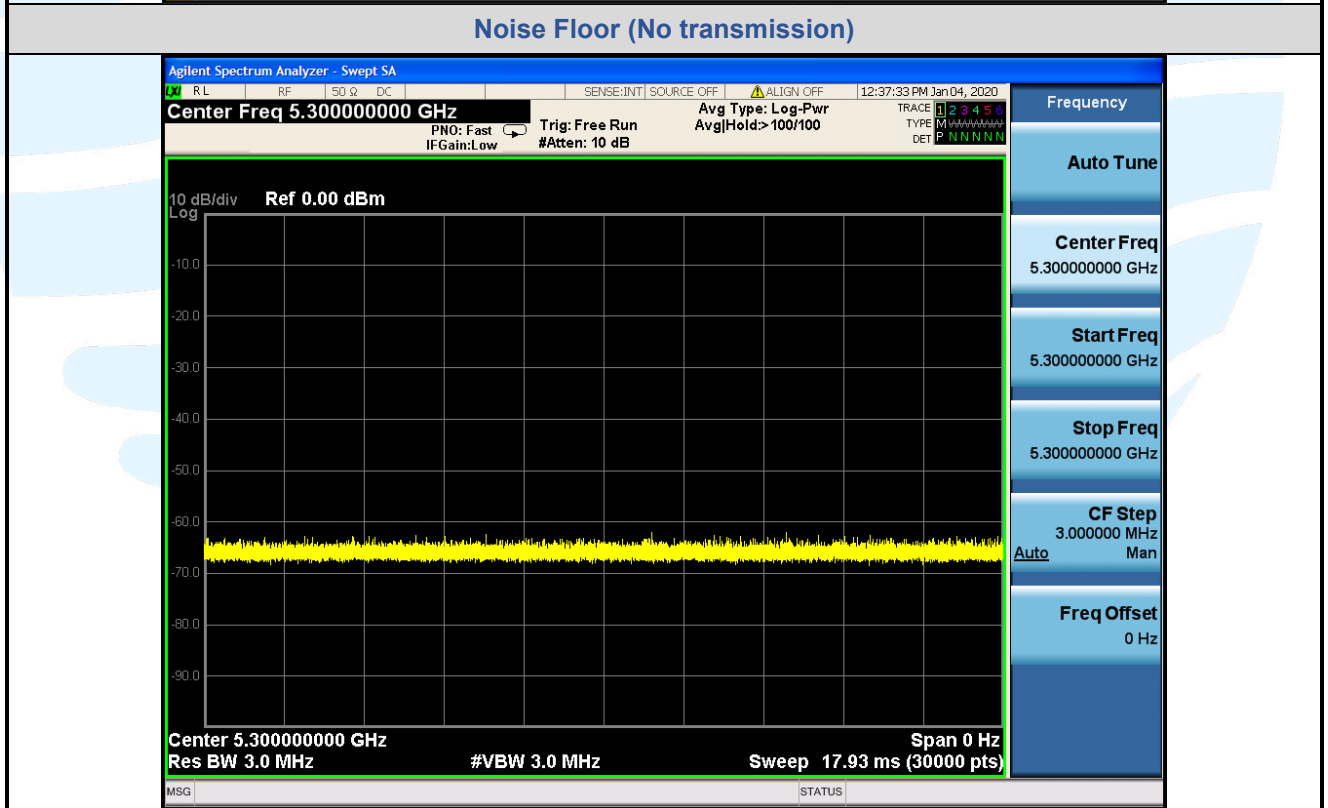
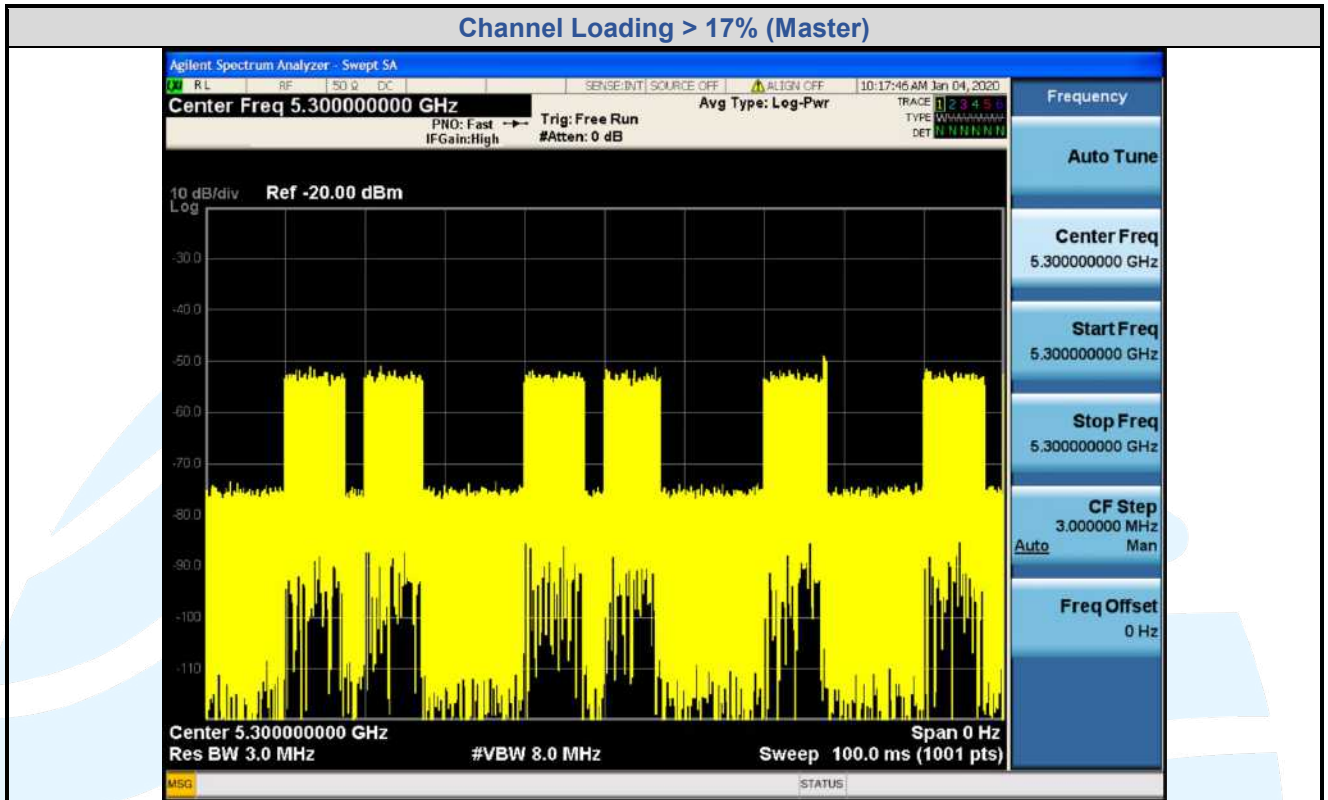

6.5 STATISTICAL PERFORMANCE CHECK (7.8.4)

6.5.1 Limit of Statistical Performance Check

Short Pulse Radar Test

Once the performance requirements check is complete, statistical data will be gathered, to determine the ability of the device to detect the radar test waveforms (Short Pulse Radar Types 1-4) found in Table 5. The device can utilize a test mode to demonstrate when detection occurs to prevent the need to reset the device between trials. The percentage of successful detection is calculated by:

$$\frac{\text{Total Wave form Detections}}{\text{Total Wave form Trials}} \times 100 = \text{Percentage of Successful Detection Radar Waveform } N = P_d N$$

In addition an aggregate minimum percentage of successful detection across all Short Pulse Radar Types 1-4 is required and is calculated as follows:

$$\frac{P_{d1} + P_{d2} + P_{d3} + P_{d4}}{4}$$

The minimum number of trails, minimum percentage of successful detection and the aggregate minimum percentage of successful detection are found in Table 5.

Table 5 – Short Pulse Radar Test Waveforms

Radar Type	Pulse Width (µsec)	PRI (µsec)	Number of Pulses	Minimum Percentage of Successful Detection	Minimum Number of Trials
1	1	1428	18	60%	30
2	1-5	150-230	23-29	60%	30
3	6-10	200-500	16-18	60%	30
4	11-20	200-500	12-16	60%	30
Aggregate (Radar Types 1-4)				80%	120

A minimum of 30 unique waveforms are required for each of the Short Pulse Radar Types 1 through 4. For Short Pulse Radar Type 0, the same waveform is used a minimum of 30 times. If more than 30 waveforms are used for Short Pulse Radar Types 1 through 4, then each additional waveform must also be unique and not repeated from the previous waveforms.

Radar Type	Number of Trials	Number of Successful Detections	Minimum Percentage of Successful Detection
1	35	29	82.9%
2	30	18	60%
3	30	27	90%
4	50	44	88%
Aggregate (82.9% + 60% + 90% + 88%)/4 = 80.2%			

Long Pulse Radar Test

Statistical data will be gathered to determine the ability of the device to detect the Long Pulse Radar Type 5 found in Table 6. The device can utilize a test mode to demonstrate when detection occurs to prevent the need to reset the device between trials. The percentage of successful detection is calculated by:

$$\frac{\text{Total Wave form Detections}}{\text{Total Wave form Trials}} \times 100$$

Table 6 –Long Pulse Radar Test Waveform

Radar Type	Pulse Width (μsec)	Chirp Width (MHz)	PRI (μsec)	Number of Pulses per Burst	Number of Bursts	Minimum Percentage of Successful Detection	Minimum Number of Trials
5	50-100	5-20	1000-2000	1-3	8-20	80%	30

The parameters for this waveform are randomly chosen. Thirty unique waveforms are required for the Long Pulse Radar Type waveforms. If more than 30 waveforms are used for the Long Pulse Radar Type waveforms, then each additional waveform must also be unique and not repeated from the previous waveforms.

Frequency Hopping Radar Test

Statistical data will be gathered to determine the ability of the device to detect the Frequency Hopping radar test signal (radar type 6) found in Table 7. The device can utilize a test mode to demonstrate when detection occurs to prevent the need to reset the device between trial runs. The probability of successful detection is calculated by:

$$\frac{\text{Total Wave form Detections}}{\text{Total Wave form Trials}} \times 100$$

Table 7 –Frequency Hopping Radar Test Waveform

Radar Type	Pulse Width (μsec)	PRI (μsec)	Pulses per Hop	Hopping Rate (kHz)	Hopping Sequence Length (msec)	Minimum Percentage of Successful Detection	Minimum Number of Trials
6	1	333	9	0.333	300	70%	30

For the Frequency Hopping Radar Type, the same Burst parameters are used for each waveform. The hopping sequence is different for each waveform and a 100-length segment is selected from the hopping sequence defined by the following algorithm:

The first frequency in a hopping sequence is selected randomly from the group of 475 integer frequencies from 5250 – 5724 MHz. Next, the frequency that was just chosen is removed from the group and a frequency is randomly selected from the remaining 474 frequencies in the group. This process continues until all 475 frequencies are chosen for the set. For selection of a random frequency, the frequencies remaining within the group are always treated as equally likely.

6.5.2 Test Procedures

- (1) One frequency will be chosen from the Operating Channels of the EUT within the 5250-5350 MHz or 5470-5725 MHz bands.
- (2) (In case the EUT is a Master Device, a U-NII device operating as a Client Device will be used and it is assumed that the Client will associate with the EUT (Master). If the Master Device has antenna gain, the main beam of the antenna will be directed toward the radar emitter. Vertical polarization is used for testing.
- (3) The TCP protocol unicast data stream was generated by the iperf software command line with at least 17% activity ratio over any 100ms period.
- (4) At time T0 the Radar Waveform generator sends a Burst of pulses for each of the Radar Types 1-6 at DFS Detection Threshold levels on the Operating Channel. An additional 1 dB is added to the radar test signal to ensure it is at or above the DFS Detection Threshold, accounting for equipment variations/errors.
- (5) Observe the transmissions of the EUT at the end of the Burst on the Operating Channel for duration greater than 10 seconds for Short Pulse Radar Types 1-4 and 6 to ensure detection occurs.
- (6) Observe the transmissions of the EUT at the end of the Burst on the Operating Channel for duration greater than 22 seconds for Long Pulse Radar Type 5 to ensure detection occurs

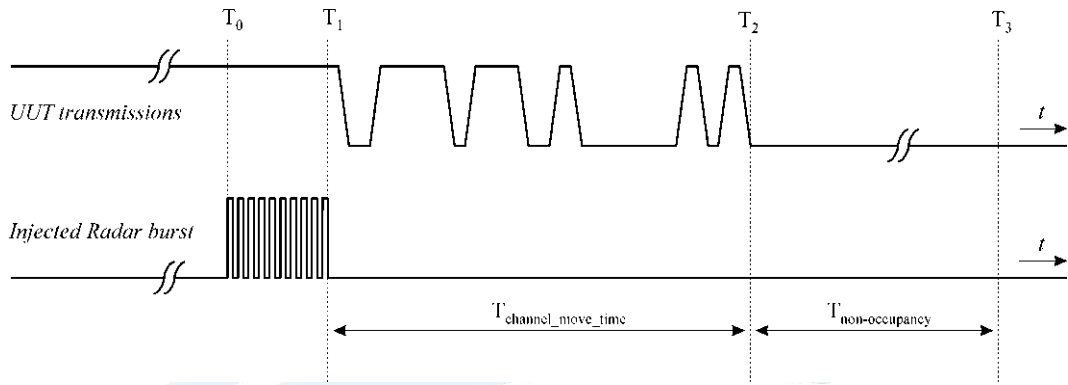

6.5.3 Test Setup

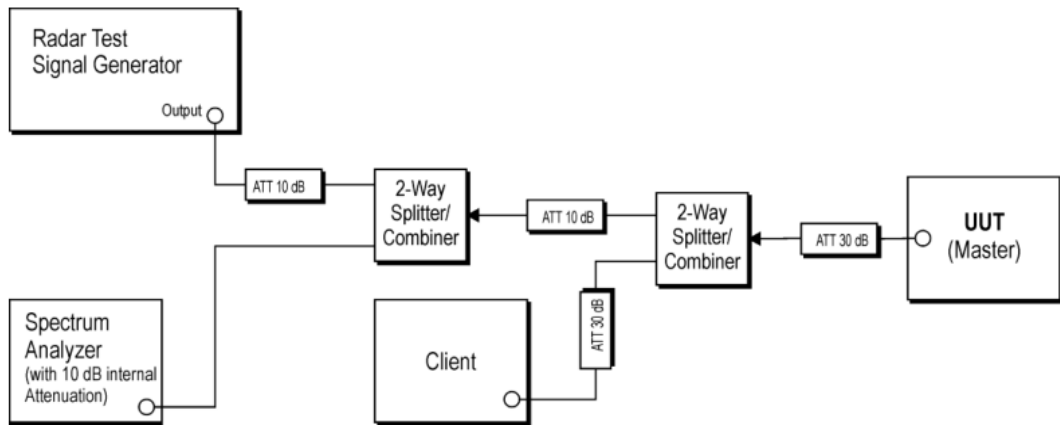

6.5.4 Test Deviation

There is no deviation with the original standard.

6.5.5 Result of Statistical Performance Check

20MHz / 5300MHz						
(Detection = Y, No Detection = N)						
Trial Number	Type 1	Type 2	Type 3	Type 4	Type 5	Type 6
1	Y	N	N	N	Y	Y
2	Y	Y	Y	Y	Y	Y
3	Y	N	N	Y	Y	Y
4	Y	Y	N	Y	Y	N
5	Y	Y	N	Y	Y	Y
6	Y	Y	Y	Y	Y	Y
7	Y	Y	N	Y	Y	Y
8	Y	Y	Y	N	Y	N
9	Y	Y	Y	Y	Y	Y
10	Y	Y	N	N	Y	Y
11	Y	Y	Y	N	Y	Y
12	Y	Y	Y	Y	Y	N
13	Y	Y	Y	Y	N	Y
14	Y	Y	Y	Y	Y	Y
15	Y	N	Y	Y	Y	Y
16	Y	N	Y	Y	Y	Y
17	Y	Y	Y	Y	Y	N
18	N	Y	Y	Y	N	Y
19	Y	Y	Y	Y	Y	Y
20	Y	N	Y	Y	Y	Y
21	Y	Y	Y	Y	Y	Y
22	Y	Y	Y	Y	Y	Y
23	Y	N	Y	Y	Y	Y
24	Y	Y	Y	Y	Y	Y
25	Y	Y	Y	Y	Y	Y
26	Y	Y	N	Y	N	Y
27	Y	Y	Y	Y	Y	Y
28	Y	Y	Y	Y	Y	Y
29	Y	Y	N	N	Y	Y
30	Y	Y	Y	Y	Y	Y
Trial of Detection	29/30	22/30	22/30	25/30	27/30	26/30
Probability (%)	96.7%	73.3%	73.3%	83.3%	90%	86.7%
Limit (%)	>= 60%	>= 60%	>= 60%	>= 60%	>= 80%	>= 70%
Average Probability of Radar Type 1~4 (%)	81.65% (>=80%)					

Shenzhen UnionTrust Quality and Technology Co., Ltd.

Address: 16/F, Block A, Building 6, Baoneng Science and Technology Park, Qingxiang Road No.1, Longhua New District, Shenzhen, China

Tel: +86-755-28230888

Fax: +86-755-28230886

E-mail: info@uttlab.com

<http://www.uttlab.com>

UTTR-RF-FCCPART15.407-V1.0

40MHz / 5310MHz						
(Detection = Y, No Detection = N)						
Trial Number	Type 1	Type 2	Type 3	Type 4	Type 5	Type 6
1	Y	Y	Y	Y	Y	Y
2	Y	Y	Y	Y	Y	Y
3	Y	Y	Y	Y	Y	Y
4	Y	Y	Y	Y	Y	Y
5	Y	Y	Y	N	Y	Y
6	Y	Y	Y	Y	Y	Y
7	Y	Y	Y	Y	Y	Y
8	Y	N	Y	Y	Y	Y
9	N	Y	Y	Y	Y	Y
10	Y	Y	Y	Y	N	N
11	Y	Y	Y	N	Y	Y
12	Y	Y	Y	Y	Y	Y
13	Y	N	Y	Y	Y	Y
14	Y	N	Y	Y	Y	Y
15	Y	Y	Y	Y	Y	Y
16	Y	Y	Y	Y	Y	Y
17	Y	Y	Y	Y	Y	Y
18	Y	Y	Y	Y	Y	Y
19	Y	Y	Y	Y	N	Y
20	Y	Y	Y	Y	Y	Y
21	N	Y	Y	Y	Y	Y
22	Y	Y	Y	Y	Y	Y
23	Y	Y	Y	Y	Y	Y
24	Y	Y	Y	Y	Y	Y
25	Y	Y	Y	Y	Y	Y
26	Y	Y	N	Y	N	Y
27	Y	Y	Y	Y	Y	Y
28	Y	Y	Y	Y	Y	Y
29	Y	Y	Y	N	Y	Y
30	Y	Y	Y	Y	Y	Y
Trial of Detection	28/30	27/30	29/30	27/30	27/30	29/30
Probability (%)	93.3%	90%	96.7%	90%	90%	96.7%
Limit (%)	>= 60%	>= 60%	>= 60%	>= 60%	>= 80%	>= 70%
Average Probability of Radar Type 1~4 (%)	92.5% (>=80%)					

Shenzhen UnionTrust Quality and Technology Co., Ltd.

Address: 16/F, Block A, Building 6, Baoneng Science and Technology Park, Qingxiang Road No.1, Longhua New District, Shenzhen, China

Tel: +86-755-28230888

Fax: +86-755-28230886

E-mail: info@uttlab.com

<http://www.uttlab.com>

UTTR-RF-FCCPART15.407-V1.0

80MHz / 5290MHz						
(Detection = Y, No Detection = N)						
Trial Number	Type 1	Type 2	Type 3	Type 4	Type 5	Type 6
1	Y	Y	Y	Y	Y	Y
2	Y	Y	Y	Y	Y	Y
3	Y	Y	Y	Y	Y	Y
4	Y	N	Y	Y	Y	Y
5	Y	Y	Y	Y	Y	Y
6	Y	Y	Y	Y	Y	Y
7	Y	Y	Y	Y	N	Y
8	Y	Y	Y	Y	Y	Y
9	Y	Y	Y	N	Y	Y
10	Y	N	Y	Y	Y	Y
11	Y	Y	Y	Y	Y	Y
12	Y	Y	Y	Y	Y	Y
13	Y	Y	Y	Y	Y	Y
14	Y	Y	Y	Y	N	Y
15	Y	Y	N	Y	Y	Y
16	Y	Y	Y	Y	Y	Y
17	Y	Y	Y	Y	Y	Y
18	Y	Y	Y	Y	Y	Y
19	Y	Y	Y	Y	Y	Y
20	Y	Y	Y	Y	Y	Y
21	Y	Y	Y	Y	Y	Y
22	Y	Y	Y	Y	N	N
23	Y	N	Y	Y	Y	Y
24	Y	Y	Y	Y	Y	Y
25	Y	Y	Y	N	Y	Y
26	Y	Y	N	Y	Y	Y
27	Y	Y	Y	Y	Y	Y
28	Y	Y	Y	Y	Y	Y
29	Y	Y	Y	Y	Y	Y
30	Y	Y	Y	Y	Y	Y
Trial of Detection	30/30	27/30	28/30	28/30	27/30	29/30
Probability (%)	100%	90%	93.3%	93.3%	90%	97.8%
Limit (%)	>= 60%	>= 60%	>= 60%	>= 60%	>= 80%	>= 70%
Average Probability of Radar Type 1~4 (%)	94.15% (>=80%)					

Shenzhen UnionTrust Quality and Technology Co., Ltd.

Address: 16/F, Block A, Building 6, Baoneng Science and Technology Park, Qingxiang Road No.1, Longhua New District, Shenzhen, China

Tel: +86-755-28230888

Fax: +86-755-28230886

E-mail: info@uttlab.com

<http://www.uttlab.com>

UTTR-RF-FCCPART15.407-V1.0

20MHz / 5500MHz						
(Detection = Y, No Detection = N)						
Trial Number	Type 1	Type 2	Type 3	Type 4	Type 5	Type 6
1	Y	Y	Y	Y	Y	Y
2	Y	N	Y	Y	Y	Y
3	Y	Y	N	Y	Y	Y
4	Y	Y	Y	Y	N	Y
5	Y	Y	Y	Y	Y	Y
6	Y	Y	Y	Y	Y	Y
7	Y	Y	Y	N	Y	Y
8	Y	Y	Y	Y	Y	Y
9	Y	Y	Y	N	Y	Y
10	Y	Y	Y	Y	Y	Y
11	Y	Y	Y	N	N	Y
12	Y	Y	Y	N	Y	N
13	Y	Y	Y	Y	Y	Y
14	Y	Y	Y	N	Y	Y
15	Y	Y	Y	N	Y	Y
16	Y	Y	Y	N	N	Y
17	Y	Y	Y	Y	N	Y
18	Y	Y	Y	N	Y	Y
19	Y	Y	Y	Y	Y	Y
20	Y	Y	Y	Y	Y	Y
21	Y	Y	N	Y	Y	Y
22	Y	Y	N	Y	N	Y
23	Y	Y	Y	Y	Y	Y
24	Y	Y	N	Y	Y	Y
25	Y	N	N	Y	Y	Y
26	Y	Y	N	Y	Y	Y
27	Y	N	N	Y	Y	Y
28	Y	N	Y	Y	Y	Y
29	Y	N	Y	Y	Y	Y
30	Y	Y	N	Y	Y	Y
Trial of Detection	30/30	25/30	22/30	22/30	25/30	29/30
Probability (%)	100%	83.3%	73.3%	73.3%	83.3%	96.7%
Limit (%)	>= 60%	>= 60%	>= 60%	>= 60%	>= 80%	>= 70%
Average Probability of Radar Type 1~4 (%)	82.475% (>=80%)					

Shenzhen UnionTrust Quality and Technology Co., Ltd.

Address: 16/F, Block A, Building 6, Baoneng Science and Technology Park, Qingxiang Road No.1, Longhua New District, Shenzhen, China

Tel: +86-755-28230888

Fax: +86-755-28230886

E-mail: info@uttlab.com

<http://www.uttlab.com>

UTTR-RF-FCCPART15.407-V1.0

40MHz / 5510MHz						
(Detection = Y, No Detection = N)						
Trial Number	Type 1	Type 2	Type 3	Type 4	Type 5	Type 6
1	Y	Y	Y	N	Y	Y
2	Y	Y	Y	Y	Y	Y
3	Y	Y	Y	Y	Y	Y
4	Y	Y	Y	Y	Y	Y
5	Y	Y	Y	Y	Y	Y
6	Y	Y	Y	Y	Y	Y
7	Y	Y	Y	Y	Y	Y
8	Y	Y	Y	Y	Y	Y
9	Y	Y	Y	Y	Y	N
10	Y	Y	Y	Y	Y	Y
11	Y	Y	Y	Y	Y	Y
12	Y	Y	Y	Y	Y	Y
13	Y	Y	Y	Y	Y	Y
14	Y	Y	Y	Y	Y	Y
15	Y	Y	Y	Y	Y	Y
16	Y	Y	Y	Y	N	Y
17	Y	Y	Y	Y	Y	N
18	Y	Y	Y	Y	N	N
19	Y	Y	Y	Y	Y	Y
20	Y	Y	Y	Y	Y	Y
21	N	Y	Y	Y	Y	Y
22	Y	Y	Y	Y	Y	Y
23	Y	N	Y	Y	Y	N
24	Y	Y	Y	Y	Y	Y
25	Y	Y	Y	Y	Y	Y
26	Y	Y	Y	Y	Y	Y
27	Y	Y	Y	Y	Y	N
28	Y	Y	Y	Y	N	Y
29	Y	Y	Y	Y	Y	Y
30	Y	Y	Y	N	Y	Y
Trial of Detection	29/30	29/30	30/30	28/30	27/30	25/30
Probability (%)	96.7%	96.7%	100%	93.3%	90%	83.3%
Limit (%)	>= 60%	>= 60%	>= 60%	>= 60%	>= 80%	>= 70%
Average Probability of Radar Type 1~4 (%)	96.675% (>=80%)					

Shenzhen UnionTrust Quality and Technology Co., Ltd.

Address: 16/F, Block A, Building 6, Baoneng Science and Technology Park, Qingxiang Road No.1, Longhua New District, Shenzhen, China

Tel: +86-755-28230888

Fax: +86-755-28230886

E-mail: info@uttlab.com

<http://www.uttlab.com>

UTTR-RF-FCCPART15.407-V1.0

80MHz / 5530MHz						
(Detection = Y, No Detection = N)						
Trial Number	Type 1	Type 2	Type 3	Type 4	Type 5	Type 6
1	Y	Y	Y	Y	Y	Y
2	Y	Y	Y	Y	Y	Y
3	Y	Y	Y	Y	Y	Y
4	Y	Y	Y	Y	Y	Y
5	Y	Y	Y	Y	N	Y
6	Y	Y	Y	N	Y	Y
7	Y	Y	Y	N	N	N
8	Y	N	Y	Y	Y	Y
9	Y	Y	Y	Y	Y	Y
10	Y	Y	N	Y	Y	N
11	Y	Y	Y	Y	Y	Y
12	Y	Y	Y	Y	Y	Y
13	Y	Y	Y	Y	Y	Y
14	Y	Y	Y	Y	Y	Y
15	Y	Y	Y	Y	Y	Y
16	Y	Y	Y	Y	Y	Y
17	N	Y	Y	Y	N	N
18	Y	Y	Y	Y	Y	Y
19	Y	N	Y	Y	Y	Y
20	Y	Y	Y	Y	Y	N
21	Y	Y	Y	Y	N	Y
22	Y	Y	Y	Y	Y	N
23	Y	Y	Y	Y	Y	Y
24	Y	Y	Y	Y	Y	Y
25	Y	Y	Y	Y	Y	Y
26	Y	Y	Y	Y	Y	Y
27	Y	Y	Y	Y	Y	Y
28	Y	Y	Y	Y	Y	Y
29	Y	Y	Y	Y	Y	Y
30	Y	Y	Y	Y	Y	Y
Trial of Detection	29/30	28/30	29/30	28/30	26/30	25/30
Probability (%)	96.7%	93.3%	96.7%	93.3%	86.7%	83.3%
Limit (%)	>= 60%	>= 60%	>= 60%	>= 60%	>= 80%	>= 70%
Average Probability of Radar Type 1~4 (%)	95% (>=80%)					

Shenzhen UnionTrust Quality and Technology Co., Ltd.

Address: 16/F, Block A, Building 6, Baoneng Science and Technology Park, Qingxiang Road No.1, Longhua New District, Shenzhen, China

Tel: +86-755-28230888

Fax: +86-755-28230886

E-mail: info@uttlab.com

<http://www.uttlab.com>

UTTR-RF-FCCPART15.407-V1.0

APPENDIX 1 PHOTOS OF TEST SETUP

See test photos attached in Appendix 1 for the actual connections between Product and support equipment.

APPENDIX 2 PHOTOS OF EUT CONSTRUCTIONAL DETAILS

Refer to Appendix 2 for EUT external and internal photos.

*** End of Report ***

The test report is effective only with both signature and specialized stamp. The result(s) shown in this report refer only to the sample(s) tested. Without written approval of UnionTrust, this report can't be reproduced except in full.
