

TEST REPORT

Product Name: HD Intercom & Facility Control Station
Trade Mark: GRANDSTREAM
Model No.: GSC3575
Add. Model No.: GSC3574
Report Number: 2401279067RFC-4
Test Standards: FCC 47 CFR Part 15 Subpart E
FCC ID: YZZGSC3575
Test Result: PASS
Date of Issue: May 11, 2024

Prepared for:

Grandstream Networks, Inc.
126 Brookline Ave., 3rd Floor, Boston, MA 02215, USA

Prepared by:

Shenzhen UnionTrust Quality and Technology Co., Ltd.
Unit D/E of 9/F and 16/F, Block A, Building 6, Baoneng science and technology park, Longhua district, Shenzhen, China

TEL: +86-755-2823 0888
FAX: +86-755-2823 0886

Prepared by: David Chen
 David Chen
 Senior Project Engineer

Reviewed by: Robben Chen
 Robben Chen
 Assistant Manager

Approved by: 
 Billy Li
 Technical Director

Date: May 11, 2024

Shenzhen UnionTrust Quality and Technology Co., Ltd.

Version

Version No.	Date	Description
V1.0	May 11, 2024	Original

**Shenzhen UnionTrust Quality and Technology Co., Ltd.**

Address: Unit D/E of 9/F and 16/F, Block A, Building 6, Baoneng science and technology park, Longhua district, Shenzhen, China

Tel: +86-755-28230888

Fax: +86-755-28230886

E-mail: info@uttlab.com<http://www.uttlab.com>UTTR-RF-FCCPART15.407-V1.3

CONTENTS

1. GENERAL INFORMATION	4
1.1 CLIENT INFORMATION	4
1.2 EUT INFORMATION	4
1.2.1 GENERAL DESCRIPTION OF EUT	4
1.2.2 DESCRIPTION OF ACCESSORIES	4
1.3 PRODUCT SPECIFICATION SUBJECTIVE TO THIS STANDARD	4
1.4 OTHER INFORMATION	6
1.5 DESCRIPTION OF SUPPORT UNITS	6
1.6 TEST LOCATION	6
1.7 TEST FACILITY	6
1.8 DEVIATION FROM STANDARDS	7
1.9 ABNORMALITIES FROM STANDARD CONDITIONS	7
1.10 OTHER INFORMATION REQUESTED BY THE CUSTOMER	7
1.11 MEASUREMENT UNCERTAINTY	7
2. TEST SUMMARY	8
3. EQUIPMENT LIST	9
4. TEST CONFIGURATION	10
4.1 ENVIRONMENTAL CONDITIONS FOR TESTING	10
4.1.1 NORMAL OR EXTREME TEST CONDITIONS	10
4.1.2 RECORD OF NORMAL ENVIRONMENT AND TEST SAMPLE	10
4.2 TEST CHANNELS	11
4.3 EUT TEST STATUS	11
4.4 PRE-SCAN	12
4.5 TEST SETUP	13
4.5.1 FOR RADIATED EMISSIONS TEST SETUP	13
4.5.2 FOR CONDUCTED EMISSIONS TEST SETUP	14
4.5.3 FOR CONDUCTED RF TEST SETUP	15
4.6 SYSTEM TEST CONFIGURATION	16
4.7 DUTY CYCLE	17
5. RADIO TECHNICAL REQUIREMENTS SPECIFICATION	21
5.1 REFERENCE DOCUMENTS FOR TESTING	21
5.2 ANTENNA REQUIREMENT	21
5.3 26 DB BANDWIDTH & OCCUPIED BANDWIDTH	22
5.4 6 DB BANDWIDTH & OCCUPIED BANDWIDTH	23
5.5 MAXIMUM CONDUCTED OUTPUT POWER OR E.I.R.P	24
5.6 PEAK POWER SPECTRAL DENSITY	28
5.7 RADIATED EMISSIONS AND BAND EDGE MEASUREMENT	30
5.8 DYNAMIC FREQUENCY SELECTION	89
5.9 AC POWER LINE CONDUCTED EMISSION	99
APPENDIX A RF TEST DATA	102
A.1 99% BANDWIDTH	102
A.2 26dB BANDWIDTH	116
A.3 PEAK POWER SPECTRAL DENSITY	128
A.4 6DB BANDWIDTH	142
APPENDIX 1 PHOTOS OF TEST SETUP	144
APPENDIX 2 PHOTOS OF EUT CONSTRUCTIONAL DETAILS	144

1. GENERAL INFORMATION

1.1 CLIENT INFORMATION

Applicant:	Grandstream Networks, Inc.
Address of Applicant:	126 Brookline Ave., 3rd Floor, Boston, MA 02215, USA
Manufacturer:	Grandstream Networks, Inc.
Address of Manufacturer:	126 Brookline Ave., 3rd Floor, Boston, MA 02215, USA

1.2 EUT INFORMATION

1.2.1 General Description of EUT

Product Name:	HD Intercom & Facility Control Station		
Model No.:	GSC3575		
Add. Model No.:	GSC3574		
Trade Mark:	GRANDSTREAM		
DUT Stage:	Identical Prototype		
EUT Supports Function: (Provided by the customer)	2.4 GHz ISM Band:	IEEE 802.11b/g/n/ax	
		Bluetooth V5.0	
	5 GHz U-NII Bands:	5 150 MHz to 5 250 MHz	IEEE 802.11a/n/ac/ax
		5 250 MHz to 5 350 MHz	IEEE 802.11a/n/ac/ax
		5 470 MHz to 5 725 MHz	IEEE 802.11a/n/ac/ax
	5 725 MHz to 5 850 MHz	IEEE 802.11a/n/ac/ax	
Sample Received Date:	January 26, 2024		
Sample Tested Date:	February 27, 2024 to April 13, 2024		

Remark: The above EUT's information was provided by customer. Please refer to the specifications or user's manual for more detailed description.

1.2.2 Description of Accessories

Others
1x Metal Bracket, 1x Plastic Bracket

1.3 PRODUCT SPECIFICATION SUBJECTIVE TO THIS STANDARD

Frequency Bands:	5150 MHz to 5250 MHz (U-NII-1)
	5250 MHz to 5350 MHz (U-NII-2A)
	5470 MHz to 5725 MHz (U-NII-2C)
	5725 MHz to 5850 MHz (U-NII-3)
Frequency Ranges:	5180 MHz to 5240 MHz
	5260 MHz to 5320 MHz
	5500 MHz to 5720 MHz
	5745 MHz to 5825 MHz
Support Standards:	IEEE 802.11a/n/ac/ax
TPC Function:	Not Support
DFS Operational mode:	Slave without radar Interference detection function
Type of Modulation:	IEEE 802.11a: OFDM(64QAM, 16QAM, QPSK, BPSK)
	IEEE 802.11n: OFDM(64QAM, 16QAM, QPSK, BPSK)
	IEEE 802.11ac: OFDM(256QAM, 64QAM, 16QAM, QPSK, BPSK)

Shenzhen UnionTrust Quality and Technology Co., Ltd.

	IEEE 802.11ax: OFDM /OFDMA ^{Note 1} (1024QAM, 256QAM, 64QAM, 16QAM, QPSK, BPSK)				
Channel Spacing:	IEEE 802.11a/n-HT20/ac-VHT20/ax-HE20: 20 MHz				
	IEEE 802.11n-HT40/ac-VHT40/ax-HE40: 40 MHz				
Data Rate:	IEEE 802.11a: Up to 54 Mbps				
	IEEE 802.11n-HT20: Up to MCS7				
	IEEE 802.11n-HT40: Up to MCS7				
	IEEE 802.11ac-VHT20: Up to MCS8				
	IEEE 802.11ac-VHT40: Up to MCS9				
	IEEE 802.11ax-HE20/HE40: Up to MCS11				
Number of Channels:	5150 MHz to 5250 MHz: 4 for IEEE 802.11a/n-HT20/ac-VHT20/ax-HE20 2 for IEEE 802.11n-HT40/ac-VHT40/ax-HE40				
	5250 MHz to 5350 MHz: 4 for IEEE 802.11a/n-HT20/ac-VHT20/ax-HE20 2 for IEEE 802.11n-HT40/ac-VHT40/ax-HE40				
	5470 MHz to 5725 MHz: 11 for IEEE 802.11a/n-HT20/ac-VHT20/ax-HE20 5 for IEEE 802.11n-HT40/ac-VHT40/ax-HE40				
	5725 MHz to 5850 MHz: 5 for IEEE 802.11a/n-HT20/ac-VHT20/ax-HE20 2 for IEEE 802.11n-HT40/ac-VHT40/ax-HE40				
Antenna Type:	PIFA Antenna				
Antenna Gain: (Provided by the customer)	5150 MHz to 5250 MHz: 6.45 dBi				
	5250 MHz to 5350 MHz: 6.45 dBi				
	5470 MHz to 5725 MHz: 6.45 dBi				
	5725 MHz to 5850 MHz: 6.45 dBi				
Maximum conducted output power (dBm):		U-NII-1	U-NII-2A	U-NII-2C	U-NII-3
	IEEE 802.11a:	17.73	17.38	21.30	18.81
	IEEE 802.11n-HT20:	17.57	17.68	21.25	18.72
	IEEE 802.11n-HT40:	17.39	17.48	18.27	18.95
	IEEE 802.11ac-VHT20	17.80	17.86	21.50	19.25
	IEEE 802.11ac-VHT40	17.32	17.40	21.19	18.89
	IEEE 802.11ax-HE20	17.45	17.38	21.22	18.81
	IEEE 802.11ax-HE40	17.08	17.14	19.28	18.54
Maximum EIRP (dBm):		U-NII-1	U-NII-2A	U-NII-2C	U-NII-3
	IEEE 802.11a:	24.18	23.83	27.75	25.26
	IEEE 802.11n-HT20:	24.02	24.13	27.70	25.17
	IEEE 802.11n-HT40:	23.84	23.93	24.72	25.40
	IEEE 802.11ac-VHT20	24.25	24.31	27.95	25.70
	IEEE 802.11ac-VHT40	23.77	23.85	27.64	25.34
	IEEE 802.11ax-HE20	21.99	21.92	25.76	23.35
	IEEE 802.11ax-HE40	21.62	21.68	23.82	23.08
Normal Test Voltage:	48Vdc				
Note 1: The customer declaration that OFDMA modulation supports only the SU mode.					

Shenzhen UnionTrust Quality and Technology Co., Ltd.

1.4 OTHER INFORMATION

Operation Frequency Each of Channel				
	U-NII-1	U-NII-2A	U-NII-2C	U-NII-3
IEEE 802.11a, IEEE 802.11n-HT20, IEEE 802.11ac-VHT20 IEEE 802.11ax-HE20	f = 5000 + 5k, k = 32 + 4n			f = 5000 + 5k, k = 145 + 4n
	n = 1, ..., 4	n = 5, ..., 8	n = 17, ..., 27	n = 1, ..., 5
IEEE 802.11n-HT40, IEEE 802.11ac-VHT40 IEEE 802.11ax-HE40	f = 5000 + 5k, k = 30 + 8n			f = 5000 + 5k, k = 143 + 8n
	n = 1, 2	n = 1, ..., 5	n = 9, ..., 13	n = 1, 2
Note: f is the operating frequency (MHz); k is the operating channel.				

1.5 DESCRIPTION OF SUPPORT UNITS

The EUT has been tested with associated equipment below.

1) Support Equipment

Description	Manufacturer	Model No.	Serial Number	FCC ID	Supplied by
Notebook	DELL	Latitude 3400	16238087894	N/A	UnionTrust
Mouse	DELL	MS111	CN-011D3V-738	N/A	UnionTrust
Wireless Home Router	SAGEMCOM	FAST5280	253703944	VW3FAST5280	UnionTrust
Key-Press Attenuator	Huaxin	KT2.5-90/1S-2S	N/A	N/A	UnionTrust
4 Way Divider	WOKEN	0120A040560002D	N/A	N/A	UnionTrust

2) Support Cable

Cable No.	Description	Connector	Length	Supplied by
1	Antenna Cable	SMA	0.1Meter	UnionTrust

1.6 TEST LOCATION

Shenzhen UnionTrust Quality and Technology Co., Ltd.

Address: Unit D/E of 9/F and 16/F, Block A, Building 6, Baoneng science and technology park, Longhua district, Shenzhen, China

Telephone: +86 (0) 755 2823 0888

Fax: +86 (0) 755 2823 0886

1.7 TEST FACILITY

The test facility is recognized, certified, or accredited by the following organizations:

CNAS-Lab Code: L9069

The measuring equipment utilized to perform the tests documented in this report has been calibrated once a year or in accordance with the manufacturer's recommendations, and is traceable under the ISO/IEC 17025 to

Shenzhen UnionTrust Quality and Technology Co., Ltd.

Address: Unit D/E of 9/F and 16/F, Block A, Building 6, Baoneng science and technology park, Longhua district, Shenzhen, China

Tel: +86-755-28230888

Fax: +86-755-28230886

E-mail: info@uttlab.com

<http://www.uttlab.com>

UTTR-RF-FCCPART15.407-V1.3

international or national standards. Equipment has been calibrated by accredited calibration laboratories.

A2LA-Lab Certificate No.: 4312.01

Shenzhen UnionTrust Quality and Technology Co., Ltd. has been accredited by A2LA for technical competence in the field of electrical testing, and proved to be in compliance with ISO/IEC 17025 General Requirements for the Competence of Testing and Calibration Laboratories and any additional program requirements in the identified field of testing.

ISED Wireless Device Testing Laboratories

CAB identifier: CN0032

FCC Accredited Lab.

Designation Number: CN1194

Test Firm Registration Number: 259480

1.8 DEVIATION FROM STANDARDS

None.

1.9 ABNORMALITIES FROM STANDARD CONDITIONS

None.

1.10 OTHER INFORMATION REQUESTED BY THE CUSTOMER

None.

1.11 MEASUREMENT UNCERTAINTY

Where relevant, the following measurement uncertainty levels have been estimated for tests performed on the Product as specified in CISPR 16-4-2. This uncertainty represents an expanded uncertainty expressed at approximately the 95% confidence level using a coverage factor of k=2.

No.	Item	Measurement Uncertainty
1	Conducted emission 9kHz-150kHz	±3.2 dB
2	Conducted emission 150kHz-30MHz	±2.7 dB
3	Radiated emission 9kHz-30MHz	± 4.7 dB
4	Radiated emission 30MHz-1GHz	± 4.9 dB
5	Radiated emission 1GHz-18GHz	± 4.8 dB
6	Radiated emission 18GHz-26GHz	± 5.1 dB
7	Radiated emission 26GHz-40GHz	± 5.1 dB
8	Conducted spurious emissions	± 2.7 dB
9	RF Power, Conducted	± 0.68 dB
10	Occupied Bandwidth	± 1.86 %
11	Radio Frequency	5.6 GHz: ± 6.4 x 10 ⁻⁸
12	Transmission Time	± 0.19 %

Shenzhen UnionTrust Quality and Technology Co., Ltd.

Address: Unit D/E of 9/F and 16/F, Block A, Building 6, Baoneng science and technology park, Longhua district, Shenzhen, China
 Tel: +86-755-28230888 Fax: +86-755-28230886 E-mail: info@uttlab.com <http://www.uttlab.com>
UTTR-RF-FCCPART15.407-V1.3

2. TEST SUMMARY

FCC 47 CFR Part 15 Subpart E Test Cases			
Test Item	Test Requirement	Test Method	Result
Antenna Requirement	FCC 47 CFR Part 15 Subpart C Section 15.203 FCC 47 CFR Part 15 Subpart E Section 15.407(a)(1)(2)	N/A	PASS
26 dB emission bandwidth	FCC 47 CFR Part 15 Subpart E Section 15.407 (a)(2)(5)	KDB 789033 D02 v02r01 Section C.1	PASS
6 dB bandwidth	FCC 47 CFR Part 15 Subpart E Section 15.407 (e)	KDB 789033 D02 v02r01 Section C.2	PASS
Maximum conducted output power	FCC 47 CFR Part 15 Subpart E Section 15.407 (a)(1)(2)(3)	KDB 789033 D02 v02r01 Section E.3.a (Method PM)	PASS
Peak Power Spectral Density	FCC 47 CFR Part 15 Subpart E Section 15.407 (a)(1)(2)(3)	KDB 789033 D02 v02r01 Section F	PASS
Radiated Emissions and Band Edge Measurement	FCC 47 CFR Part 15 Subpart E Section 15.407 (b)(1)(2)(3)(4)(6) FCC 47 CFR Part 15 Subpart C Section 15.209/205	KDB 789033 D02 v02r01 Section G.3, G.4, G.5, and G.6	PASS
Dynamic Frequency Selection	FCC 47 CFR Part 15 Subpart E Section 15.407 (h)	KDB 905462 D03 Client Without DFS New Rules v01r02	PASS
AC Power Line Conducted Emission	FCC 47 CFR Part 15 Subpart E Section 15.407 (b)(6) FCC 47 CFR Part 15 Subpart C Section 15.207	ANSI C63.10-2013, Section 6.2.	PASS
Note: 1) N/A: In this whole report not applicable.			
Disclaimer and Explanations: The declared of product specification and data (e.g. antenna gain, RF specification, etc) for EUT presented in the report are provided by the customer, and the customer takes all the responsibilities for the accuracy of product specification.			

For Dynamic Frequency Selection

Test Case	Result
Channel Availability Check Time	N/A ¹
U-NII Detection Bandwidth	N/A ¹
Channel Closing Transmission Time	PASS
Channel Move Time	PASS
DFS Detection Threshold	N/A ¹
Non-Occupancy Period	N/A ¹
Note: 1) The EUT is slave, NA In this whole report not applicable.	

3. EQUIPMENT LIST

Radiated Emission Test Equipment List						
Used	Equipment	Manufacturer	Model No.	Serial Number	Cal. date	Cal. Due date
<input checked="" type="checkbox"/>	3m SAC	ETS-LINDGREN	3m	Euroshiedpn-CT001270-1317	11-Nov-2023	10-Nov-2026
<input checked="" type="checkbox"/>	Receiver	R&S	ESIB26	100114	27-Oct-2023	26-Oct-2024
<input checked="" type="checkbox"/>	Loop Antenna	ETS-LINDGREN	6502	00202525	30-Oct-2023	29-Oct-2024
<input checked="" type="checkbox"/>	Broadband Antenna	ETS-LINDGREN	3142E	00201566	30-Oct-2023	29-Oct-2024
<input checked="" type="checkbox"/>	6dB Attenuator	Talent	RA6A5-N-18	18103001	30-Oct-2023	29-Oct-2024
<input checked="" type="checkbox"/>	Preamplifier	HP	8447F	2805A02960	31-Oct-2023	30-Oct-2024
<input checked="" type="checkbox"/>	Band Rejection Filter (2400MHz~2500MHz)	Micro-Tronics	BRM50702	G590	17-Jan-2024	16-Jan-2025
<input checked="" type="checkbox"/>	Double-Ridged Waveguide Horn Antenna	ETS-LINDGREN	3117-PA	00201541	16-Apr-2023	15-Apr-2024
<input checked="" type="checkbox"/>					01-Apr-2024	31-Mar-2025
<input checked="" type="checkbox"/>	Pre-amplifier	ETS-Lindgren	00118385	00201874	31-Oct-2023	30-Oct-2024
<input checked="" type="checkbox"/>	Double-Ridged Waveguide Horn Antenna	ETS-LINDGREN	3116C-PA	00202652	30-Oct-2023	29-Oct-2024
<input checked="" type="checkbox"/>					30-Oct-2023	29-Oct-2024
<input checked="" type="checkbox"/>	Pre-amplifier	ETS-Lindgren	00118384	00202652	30-Oct-2023	29-Oct-2024
<input checked="" type="checkbox"/>	Multi device Controller	ETS-LINDGREN	7006-001	00160105	N/A	N/A
<input checked="" type="checkbox"/>	Test Software	Audix	e3	Software Version: 9.160323		

Conducted Emission Test Equipment List						
Used	Equipment	Manufacturer	Model No.	Serial Number	Cal. date	Cal. Due date
<input checked="" type="checkbox"/>	Receiver	R&S	ESR7	1316.3003K07-101181-K3	27-Oct-2023	26-Oct-2024
<input checked="" type="checkbox"/>	Pulse Limiter	R&S	ESH3-Z2	0357.8810.54	27-Oct-2023	26-Oct-2024
<input checked="" type="checkbox"/>	LISN	R&S	ESH2-Z5	860014/024	27-Oct-2023	26-Oct-2024
<input checked="" type="checkbox"/>	LISN	ETS-Lindgren	3816/2SH	00201088	27-Oct-2023	26-Oct-2024
<input checked="" type="checkbox"/>	Test Software	EZ-EMC	EZ-CON	Software Version: EMC-CON 3A1.1		

Conducted RF test Equipment List						
Used	Equipment	Manufacturer	Model No.	Serial Number	Cal. date	Cal. Due date
<input checked="" type="checkbox"/>	EXA Spectrum Analyzer	KEYSIGHT	N9020A	MY51286807	27-Oct-2023	26-Oct-2024
<input checked="" type="checkbox"/>	USB Wideband Power Sensor	KEYSIGHT	U2021XA	MY55430035	27-Oct-2023	26-Oct-2024
<input type="checkbox"/>	MXG X-Series RF Vector Signal Generator	KEYSIGHT	N5182B	MY51350267	27-Oct-2023	26-Oct-2024

Shenzhen UnionTrust Quality and Technology Co., Ltd.

4. TEST CONFIGURATION

4.1 ENVIRONMENTAL CONDITIONS FOR TESTING

4.1.1 Normal or Extreme Test Conditions

Environment Parameter	Selected Values During Tests		
Test Condition	Ambient		
	Temperature (°C)	Voltage (V)	Relative Humidity (%)
NT/NV	+15 to +35	DC 12V 1.5A or DC 44-57V by PoE	20 to 75
Remark: 1) NV: Normal Voltage; NT: Normal Temperature			

4.1.2 Record of Normal Environment and Test Sample

Test Item	Temperature (°C)	Relative Humidity (%)	Pressure (kPa)	Sample No.	Tested by
26 dB emission bandwidth	22.7	56.1	100.1	S202401262671-ZJA03/4	Allen Zhou
6 dB bandwidth					
Occupied Bandwidth					
Maximum conducted output power					
Peak Power Spectral Density					
Dynamic Frequency Selection					
Radiated Emissions and Band Edge Measurement	25.8	54.1	100.2	S202401262671-ZJA02/4	Fire Huo
AC Power Line Conducted Emission	21.1	43.0	100.1	S202401262671-ZJA01/4	Linson Xie

4.2 TEST CHANNELS

Mode	Tx/Rx Frequency	Test RF Channel Lists			
		Lowest(L)	Middle(M)	Highest(H)	Straddle band
IEEE 802.11a IEEE 802.11n- HT20 IEEE 802.11ac- VHT20 IEEE 802.11ax- HE20	5150 MHz to 5250 MHz	Channel 36	Channel 44	Channel 48	--
		5180 MHz	5220 MHz	5240 MHz	--
	5250 MHz to 5350 MHz	Channel 52	Channel 60	Channel 64	--
		5260 MHz	5300 MHz	5320 MHz	--
	5470 MHz to 5725 MHz	Channel 100	Channel 116	Channel 140	Channel 144
		5500 MHz	5580 MHz	5700 MHz	5720 MHz
5725 MHz to 5850 MHz	Channel 149	Channel 157	Channel 165	--	
	5745 MHz	5785 MHz	5825 MHz	--	
IEEE 802.11n- HT40 IEEE 802.11ac- VHT40 IEEE 802.11ax- HE40	5150 MHz to 5250 MHz	Channel 38	--	Channel 46	--
		5190 MHz	--	5230 MHz	--
	5250 MHz to 5350 MHz	Channel 54	--	Channel 62	--
		5270 MHz	--	5310 MHz	--
	5470 MHz to 5725 MHz	Channel 102	Channel 110	Channel 134	Channel 142
		5510 MHz	5550 MHz	5670 MHz	5710 MHz
	5725 MHz to 5850 MHz	Channel 151	--	Channel 159	--
		5755 MHz	--	5795 MHz	--
	--	5775 MHz		--	

4.3 EUT TEST STATUS

Mode	Tx/Rx Function	Description
IEEE 802.11a/n/ac/ax	1Tx/1Rx	1. Keep the EUT in transmitting mode with all kind of modulation and all kind of data rate.

Power Setting				
	U-NII-1	U-NII-2A	U-NII-2C	U-NII-3
IEEE 802.11a	Default	Default	Default	Default
IEEE 802.11n-HT20	Default	Default	Default	Default
IEEE 802.11n-HT40	Default	Default	15	Default
IEEE 802.11ac-VHT20	Default	Default	Default	Default
IEEE 802.11ac-VHT40	Default	Default	Default	Default
IEEE 802.11ax-HE20	Default	Default	Default	Default
IEEE 802.11ax-HE40	Default	Default	16	Default

Test Software
Test software name: Command

4.4 PRE-SCAN

Pre-Scan has been conducted to determine the worst-case mode from all possible combinations between available modulations and data rate. Following data rate was (were) selected for the final test as listed below

Mode	Worst-case data rates
IEEE 802.11a	6 Mbps
IEEE 802.11n-HT20	MCS0
IEEE 802.11n-HT40	MCS0
IEEE 802.11ac-VHT20	MCS0
IEEE 802.11ac-VHT40	MCS0
IEEE 802.11ax-HE20	MCS0
IEEE 802.11ax-HE40	MCS0

4.5 TEST SETUP

4.5.1 For Radiated Emissions test setup

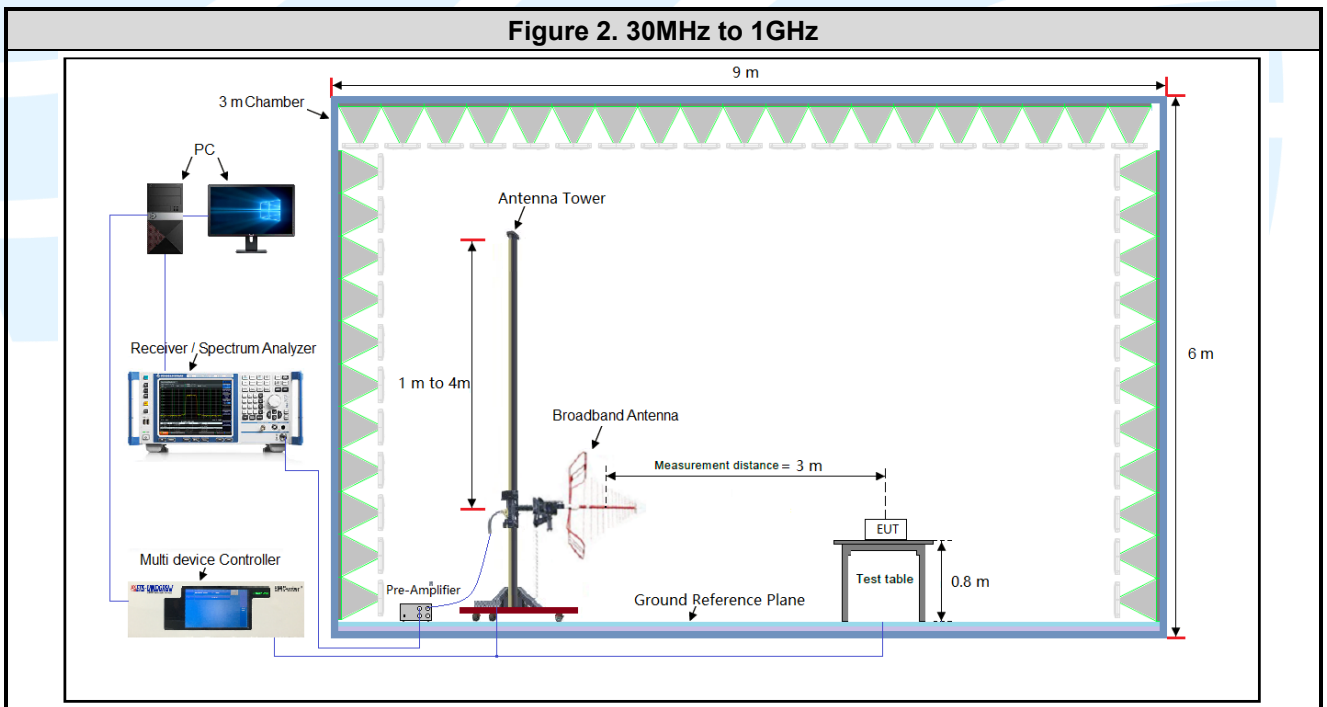
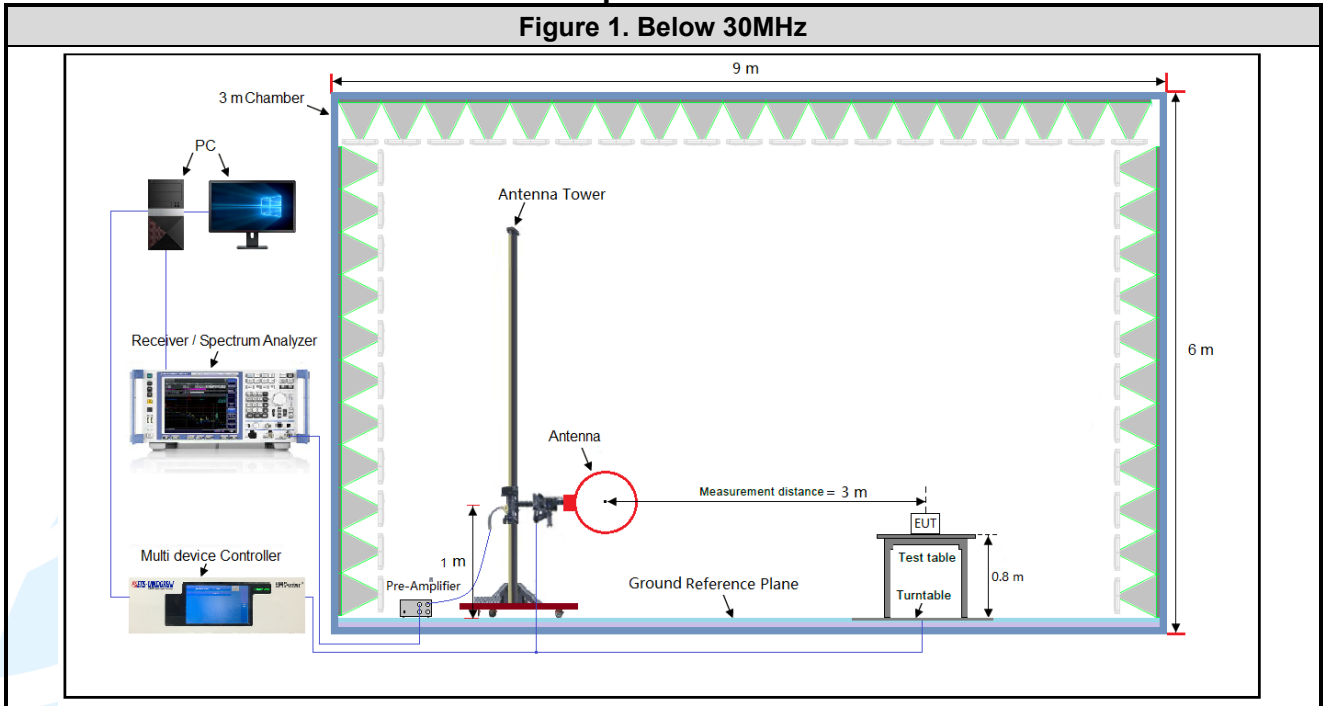

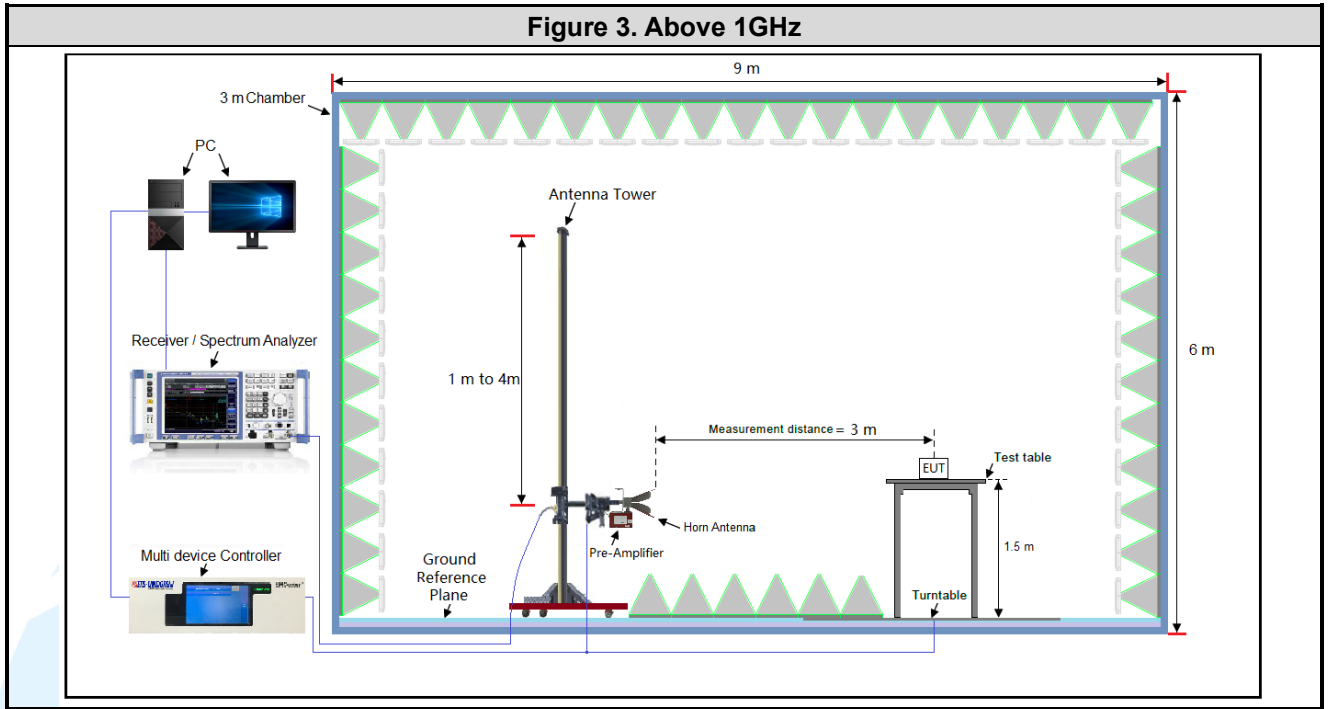

4.5.2 For Conducted Emissions test setup

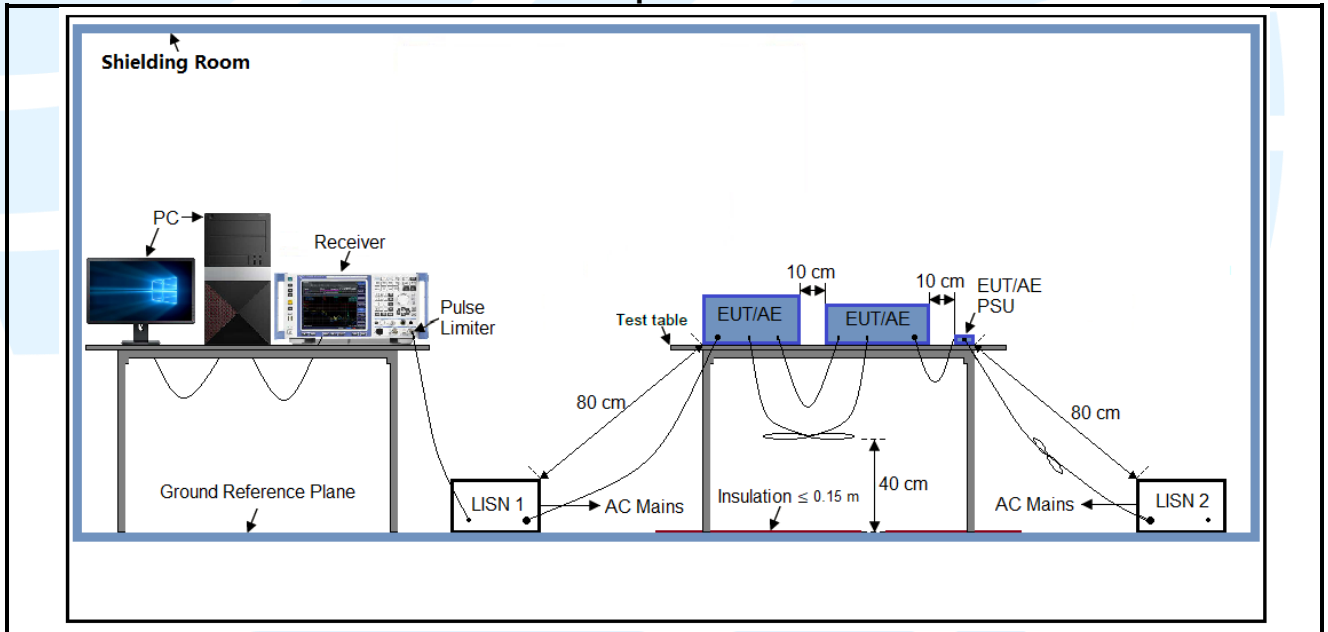

4.5.3 For Conducted RF test setup

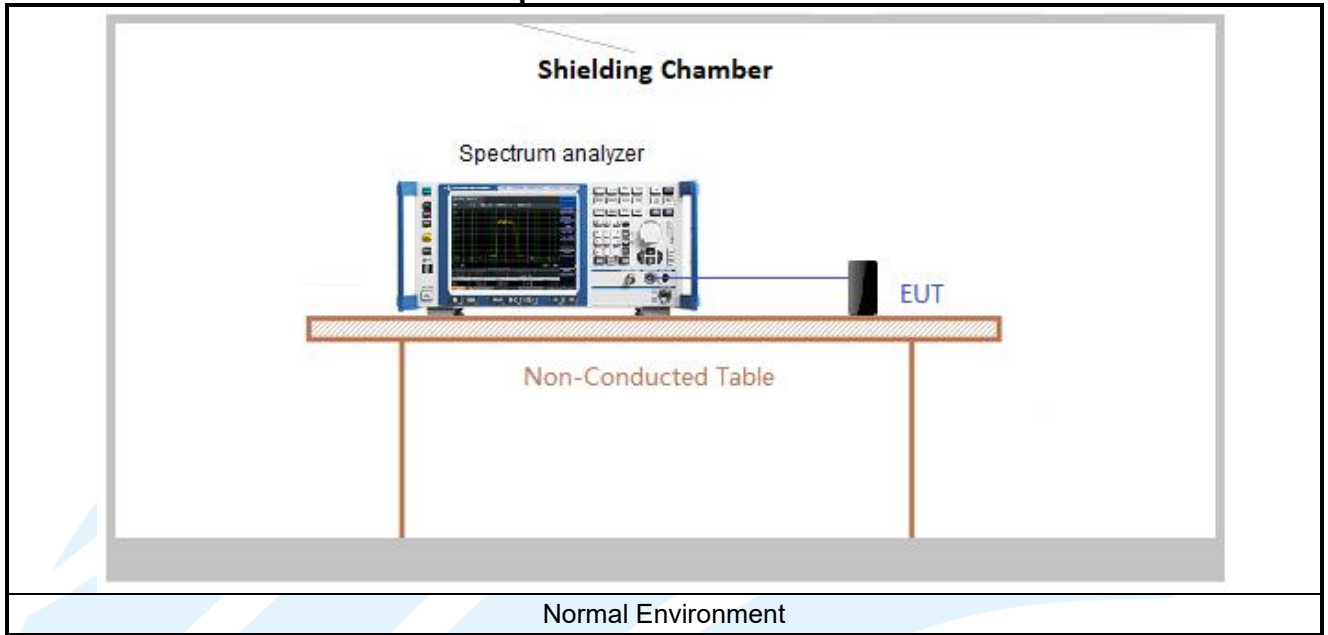

4.6 SYSTEM TEST CONFIGURATION

For emissions testing, the equipment under test (EUT) setup to transmit continuously to simplify the measurement methodology. Care was taken to ensure proper power supply voltages during testing. During testing, radiated emission were performed with the EUT set to transmit at the channel with highest output power as worst-case scenario. Only the worst case data were recorded in this test report.

The signal is maximized through rotation and placement in the three orthogonal axes. The antenna height and polarization are varied during the search for maximum signal level. The antenna height is varied from 1 to 4 meters. Radiated emissions are taken at three meters unless the signal level is too low for measurement at that distance. If necessary, a pre-amplifier is used and/or the test is conducted at a closer distance. Therefore, all final radiated testing was performed with the EUT in (see table below) orientation.

Frequency	Mode	Antenna Port	Worst-case axis positioning
Above 1GHz	1TX	Chain 0	Z axis

All readings are extrapolated back to the equivalent three meter reading using inverse scaling with distance. Analyzer resolution is 100 kHz or greater for frequencies below 1000 MHz. The resolution is 1 MHz or greater for frequencies above 1000 MHz. The spurious emissions more than 20 dB below the permissible value are not reported.

Radiated emission measurement were performed from the lowest radio frequency signal generated in the device which is greater than 9 kHz to the tenth harmonic of the highest fundamental frequency or to 40 GHz, whichever is lower.

4.7 DUTY CYCLE

Test Procedure: ANSI C63.10-2013 Clause 12.2.

Test Results

Mode	Data Rates	On Time (msec)	Period (msec)	Duty Cycle (linear)	Duty Cycle (%)	Duty Cycle Factor (dB)	1/T Minimum VBW (kHz)
IEEE 802.11a	6 Mbps	2.010	2.130	0.94	94.37	0.25	0.50
IEEE 802.11n-HT20	MCS 0	5.100	5.220	0.98	97.70	0.10	0.20
IEEE 802.11n-HT40	MCS 0	4.860	4.980	0.98	97.59	0.11	0.21
IEEE 802.11ac-VHT20	MCS 0	5.100	5.580	0.91	91.40	0.39	0.20
IEEE 802.11ac-VHT40	MCS 0	4.890	5.010	0.98	97.60	0.11	0.20
IEEE 802.11ax-HE20	MCS 0	3.870	4.020	0.96	96.27	0.17	0.26
IEEE 802.11ax-HE40	MCS 0	3.870	3.990	0.97	96.99	0.13	0.26

Remark:

- 1) Duty cycle= On Time/ Period;
- 2) Duty Cycle factor = 10 * log(1/ Duty cycle);
- 3) Average factor = 20 log₁₀ Duty Cycle.

The test plots as follows

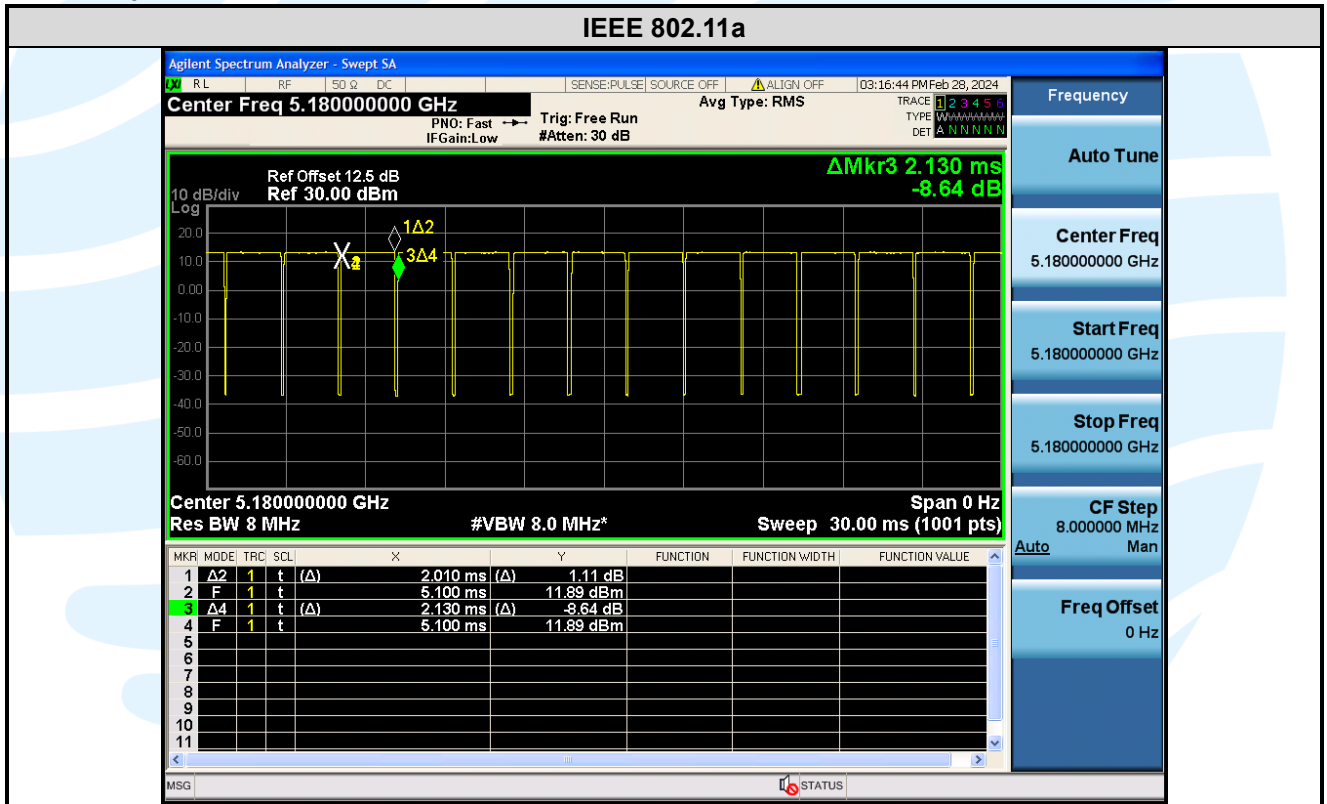

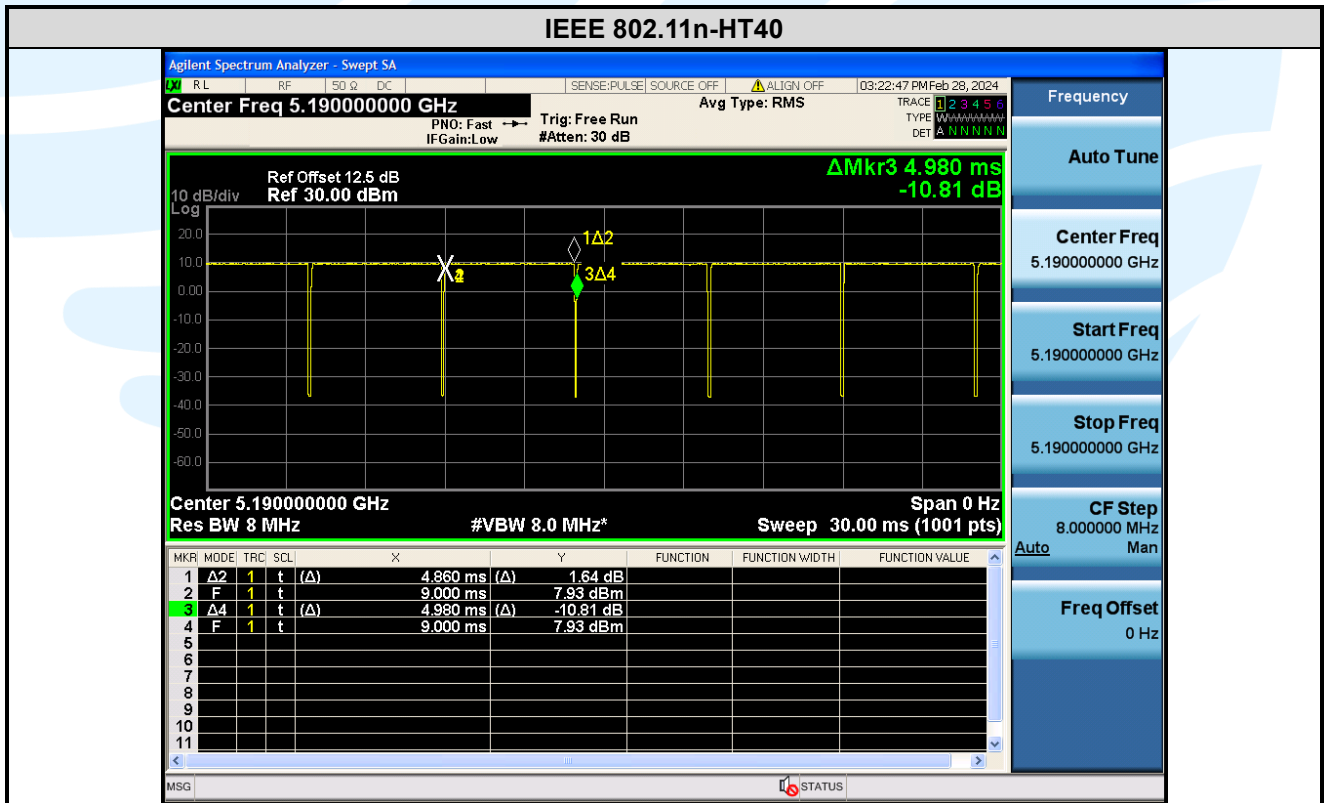
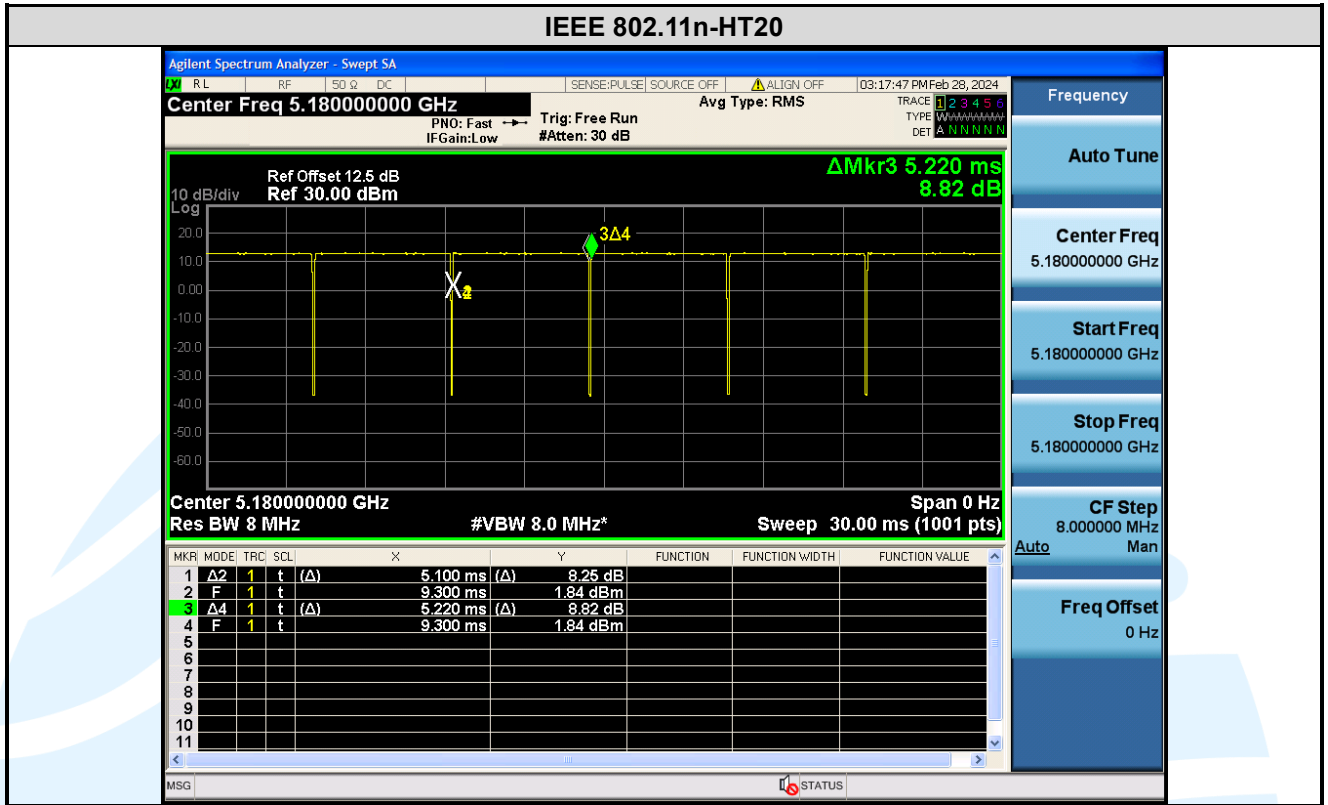

Shenzhen UnionTrust Quality and Technology Co., Ltd.

Address: Unit D/E of 9/F and 16/F, Block A, Building 6, Baoneng science and technology park, Longhua district, Shenzhen, China
 Tel: +86-755-28230888 Fax: +86-755-28230886 E-mail: info@uttlab.com <http://www.uttlab.com>
 UTR-RF-FCCPART15.407-V1.3

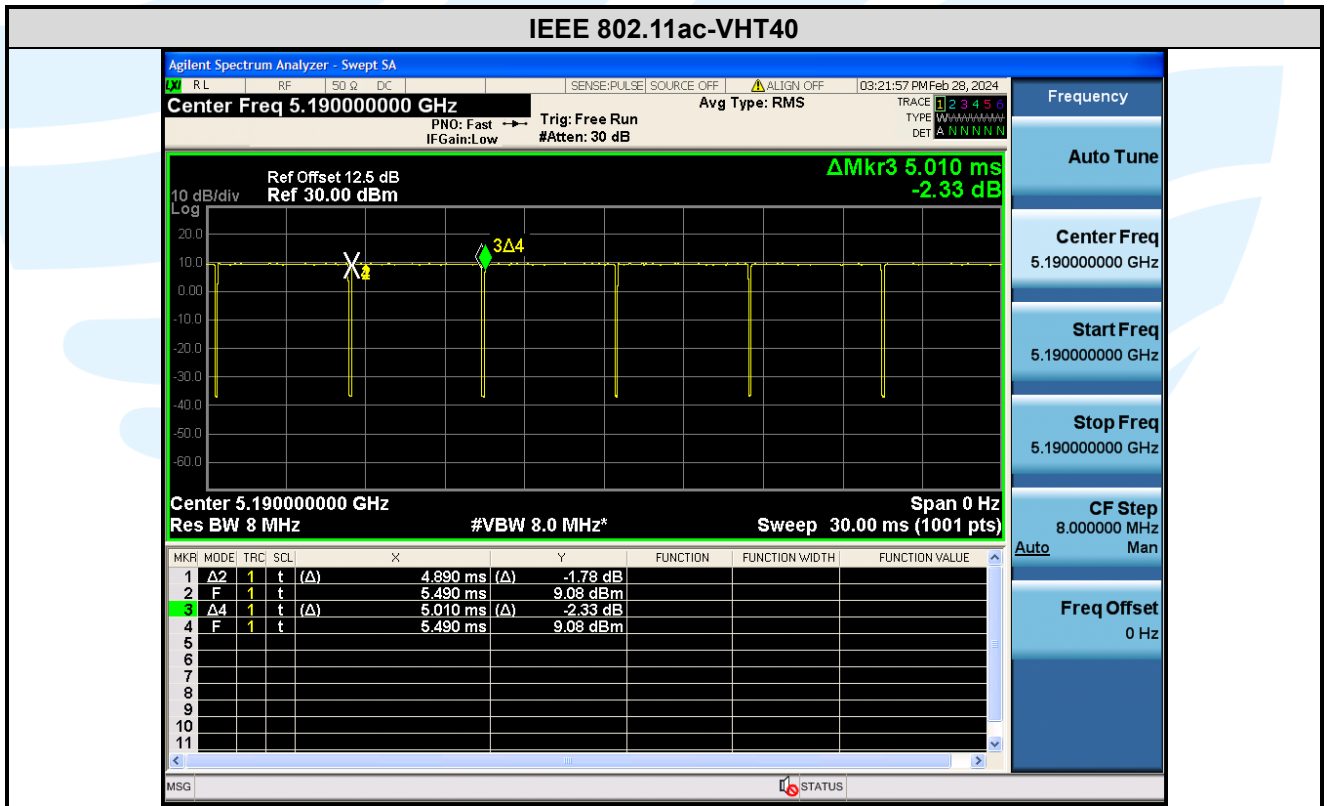
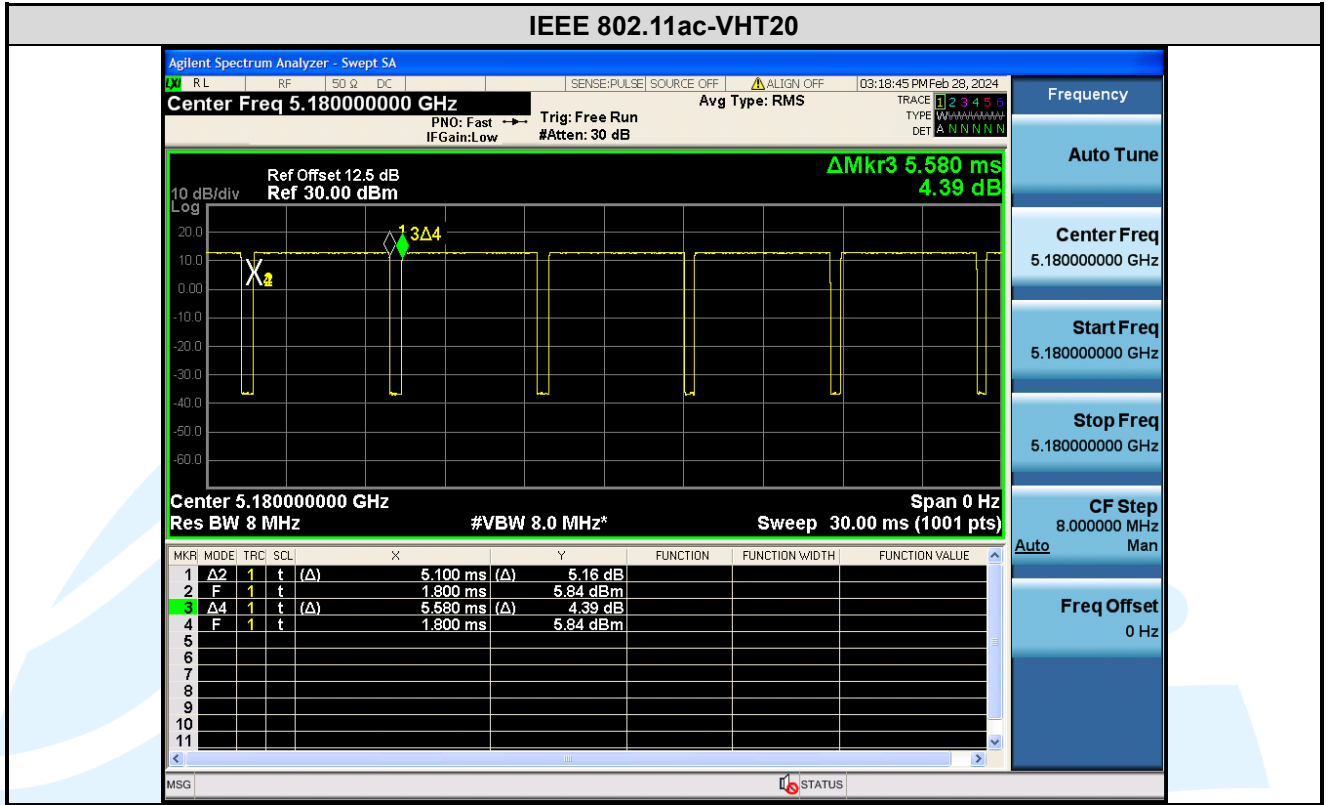

Shenzhen UnionTrust Quality and Technology Co., Ltd.

Address: Unit D/E of 9/F and 16/F, Block A, Building 6, Baoneng science and technology park, Longhua district, Shenzhen, China
 Tel: +86-755-28230888 Fax: +86-755-28230886 E-mail: info@uttlab.com <http://www.uttlab.com>
 UTR-RF-FCCPART15.407-V1.3

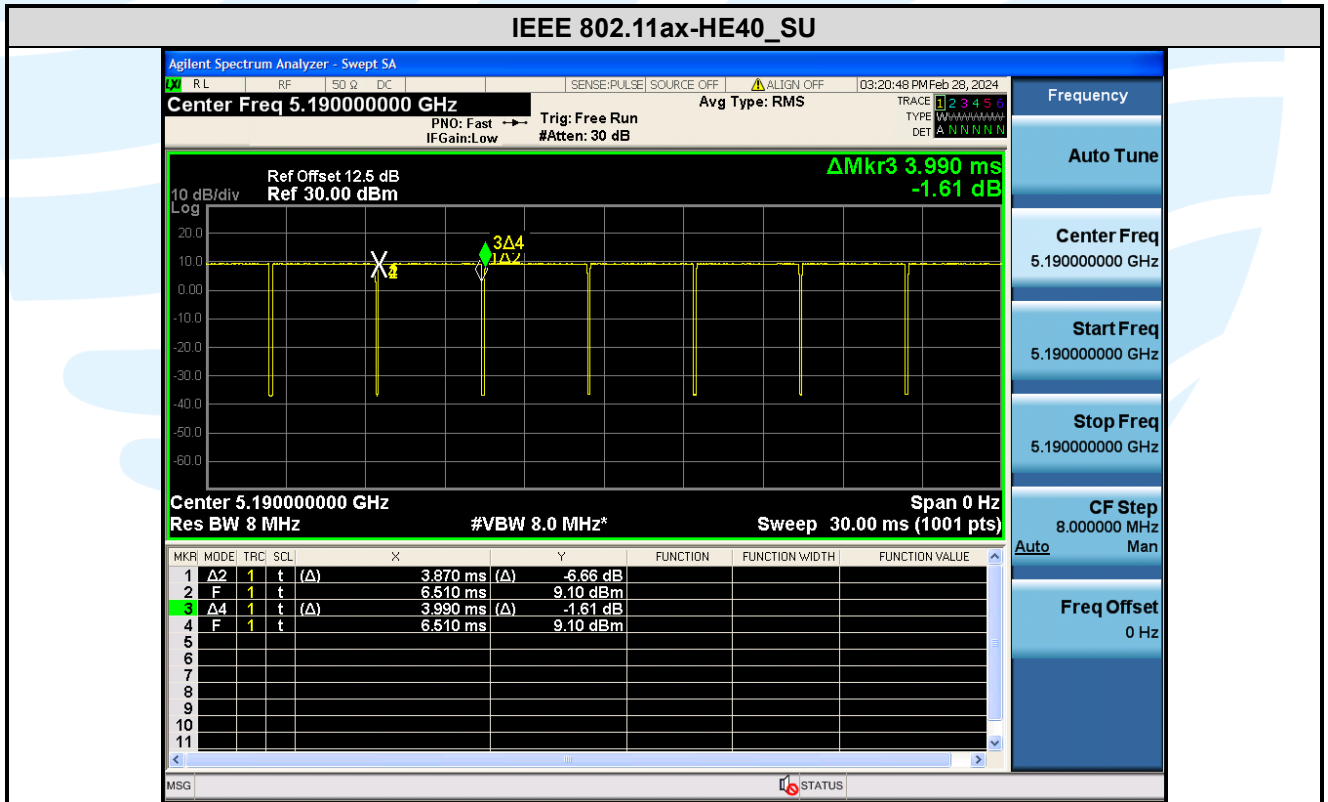
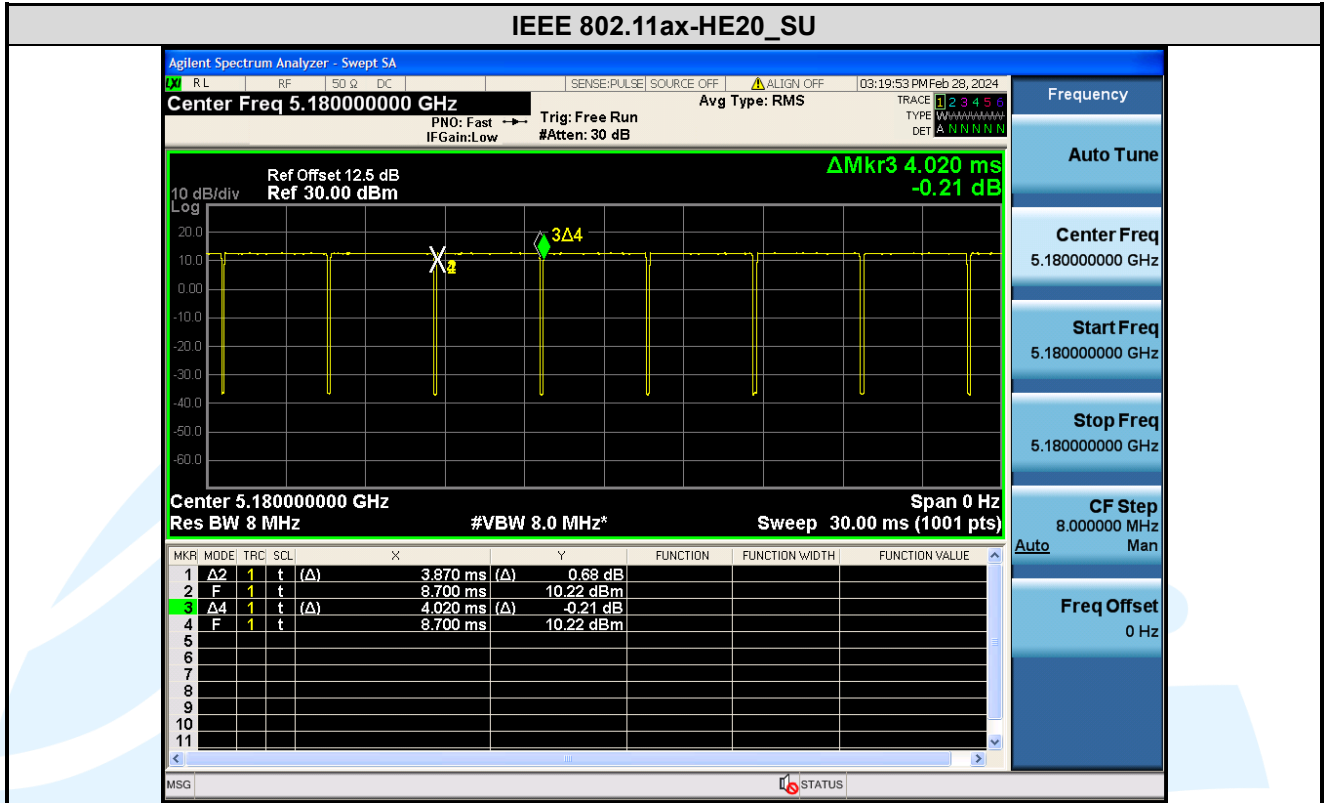

Shenzhen UnionTrust Quality and Technology Co., Ltd.

Address: Unit D/E of 9/F and 16/F, Block A, Building 6, Baoneng science and technology park, Longhua district, Shenzhen, China
 Tel: +86-755-28230888 Fax: +86-755-28230886 E-mail: info@uttlab.com <http://www.uttlab.com>
 UTR-RF-FCCPART15.407-V1.3

5. RADIO TECHNICAL REQUIREMENTS SPECIFICATION

5.1 REFERENCE DOCUMENTS FOR TESTING

No.	Identity	Document Title
1	FCC 47 CFR Part 2	Frequency allocations and radio treaty matters; general rules and regulations
2	FCC 47 CFR Part 15	Radio Frequency Devices
3	ANSI C63.10-2013	American National Standard for Testing Unlicensed Wireless Devices
4	KDB 789033 D02 General UNII Test Procedures New Rules v02r01	Guidelines for compliance testing of unlicensed national information infrastructure (U-NII) device part 15, subpart E
5	KDB 905462 D06 802.11 Channel Plans New Rules v02	Operation in U-NII bands -802.11 channel PLAN(§15.407)
6	KDB 905462 D02 UNII DFS Compliance Procedures New Rules v02	Compliance measurement procedures for Unlicensed –National Information Infrastructure devices operates in the frequency bands 5250 MHz to 5350 MHz and 5470 MHz to 5725 MHz bands incorporating dynamic frequency selection
7	KDB 905462 D03 Client Without DFS New Rules v01r02	U-NII client devices without radar detection capability

5.2 ANTENNA REQUIREMENT

Standard Requirement
<p>15.203 requirement: An intentional radiator shall be designed to ensure that no antenna other than that furnished by the responsible party shall be used with the device. The use of a permanently attached antenna or of an antenna that uses a unique coupling to the intentional radiator, the manufacturer may design the unit so that a broken antenna can be replaced by the user, but the use of a standard antenna jack or electrical connector is prohibited.</p>
<p>15.407(a)(1) (2) requirement: The conducted output power limit specified in paragraph (a) of this section is based on the use of antennas with directional gains that do not exceed 6 dBi. Except as shown in paragraph (a) of this section, if transmitting antennas of directional gain greater than 6 dBi are used, the conducted output power and the peak power spectral density shall be reduced by the by the amount in dB that the directional gain of the antenna exceeds 6 dBi.</p>
<p>EUT Antenna: Antenna in the interior of the equipment and no consideration of replacement. The gain of the antenna is 6.45 dBi.</p>

5.326 DB BANDWIDTH & OCCUPIED BANDWIDTH

Test Requirement: FCC 47 CFR Part 15 Subpart E Section 15.407 (a)(2)(5)

Test Method: KDB 789033 D02 v02r01 Section C.1

Limit: None; for reporting purposes only.

Test Procedure:

The output from the transmitter was connected to an attenuator and then to the input of the RF Spectrum analyzer.

Spectrum analyzer according to the following Settings:

a) Set RBW = approximately 1 % of the emission bandwidth.

b) Set the VBW > RBW.

c) Detector = Peak.

d) Trace mode = max hold.

e) Measure the maximum width of the emission that is 26 dB down from the peak of the emission. Compare this with the RBW setting of the analyzer. Readjust RBW and repeat measurement as needed until the RBW/EBW ratio is approximately 1 %.

Note: The cable loss and attenuator loss were offset into measure device as an amplitude offset.

Test Setup: Refer to section 4.5.3 for details.

Instruments Used: Refer to section 3 for details

Test Mode: Link mode

Test Results: Please refer to Appendix A

5.46 DB BANDWIDTH & OCCUPIED BANDWIDTH

Test Requirement: FCC 47 CFR Part 15 Subpart E Section 15.407 (e)
Test Method: KDB 789033 D02 v02r01 Section C.2
Limit: Within the 5.725-5.85 GHz band, the minimum 6 dB bandwidth of U-NII devices shall be at least 500 kHz.

Test Procedure:

The output from the transmitter was connected to an attenuator and then to the input of the RF Spectrum Analyzer.

Spectrum analyzer according to the following Settings:

6dB Bandwidth

- a) Set RBW = 100 kHz.
- b) Set the video bandwidth (VBW) $\geq 3 * RBW$.
- c) Detector = Peak.
- d) Trace mode = max hold.
- e) Sweep = auto couple.
- f) Allow the trace to stabilize.
- g) Measure the maximum width of the emission that is constrained by the frequencies associated with the two outermost amplitude points (upper and lower frequencies) that are attenuated by 6 dB relative to the maximum level measured in the fundamental emission.

Occupied Bandwidth

- a) Set RBW = 1% to 5% of the occupied bandwidth
- b) Set the video bandwidth (VBW) $\geq 3 x RBW$.
- c) Detector = Peak.
- d) Trace mode = max hold.
- e) Sweep = auto couple.
- f) Allow the trace to stabilize.

Note: The cable loss and attenuator loss were offset into measure device as an amplitude offset.

Test Setup: Refer to section 4.5.3 for details.
Instruments Used: Refer to section 3 for details
Test Mode: Transmitter mode
Test Results: Please refer to Appendix A

5.5 MAXIMUM CONDUCTED OUTPUT POWER OR E.I.R.P

Test Requirement: FCC 47 CFR Part 15 Subpart E Section 15.407 (a)(1)(2)(3)

Test Method: KDB 789033 D02 v02r01 Section E.3.a(Method PM)

Limits:

1. For the band 5.15-5.25 GHz.
 - (i) For an outdoor access point operating in the band 5.15-5.25 GHz, the maximum conducted output power over the frequency band of operation shall not exceed 1 W provided the maximum antenna gain does not exceed 6 dBi. In addition, the maximum power spectral density shall not exceed 17 dBm in any 1 megahertz band. If transmitting antennas of directional gain greater than 6 dBi are used, both the maximum conducted output power and the maximum power spectral density shall be reduced by the amount in dB that the directional gain of the antenna exceeds 6 dBi. The maximum e.i.r.p. at any elevation angle above 30 degrees as measured from the horizon must not exceed 125 mW (21 dBm).
 - (ii) For an indoor access point operating in the band 5.15-5.25 GHz, the maximum conducted output power over the frequency band of operation shall not exceed 1 W provided the maximum antenna gain does not exceed 6 dBi. In addition, the maximum power spectral density shall not exceed 17 dBm in any 1 megahertz band. If transmitting antennas of directional gain greater than 6 dBi are used, both the maximum conducted output power and the maximum power spectral density shall be reduced by the amount in dB that the directional gain of the antenna exceeds 6 dBi.
 - (iii) For fixed point-to-point access points operating in the band 5.15-5.25 GHz, the maximum conducted output power over the frequency band of operation shall not exceed 1 W. In addition, the maximum power spectral density shall not exceed 17 dBm in any 1 megahertz band. Fixed point-to-point U-NII devices may employ antennas with directional gain up to 23 dBi without any corresponding reduction in the maximum conducted output power or maximum power spectral density. For fixed point-to-point transmitters that employ a directional antenna gain greater than 23 dBi, a 1 dB reduction in maximum conducted output power and maximum power spectral density is required for each 1 dB of antenna gain in excess of 23 dBi. Fixed, point-to-point operations exclude the use of point-to-multipoint systems, omnidirectional applications, and multiple collocated transmitters transmitting the same information. The operator of the U-NII device, or if the equipment is professionally installed, the installer, is responsible for ensuring that systems employing high gain directional antennas are used exclusively for fixed, point-to-point operations.
 - (iv) For client devices in the 5.15-5.25 GHz band, the maximum conducted output power over the frequency band of operation shall not exceed 250 mW provided the maximum antenna gain does not exceed 6 dBi. In addition, the maximum power spectral density shall not exceed 11 dBm in any 1 megahertz band. If transmitting antennas of directional gain greater than 6 dBi are used, both the maximum conducted output power and the maximum power spectral density shall be reduced by the amount in dB that the directional gain of the antenna exceeds 6 dBi.
2. For the 5.25-5.35 GHz and 5.47-5.725 GHz bands, the maximum conducted output power over the frequency bands of operation shall not exceed the lesser of 250 mW or $11 \text{ dBm} + 10 \log B$, where B is the 26 dB emission bandwidth in megahertz. In addition, the maximum power spectral density shall not exceed 11 dBm in any 1 megahertz band. If transmitting antennas of directional gain greater than 6 dBi are used, both the maximum conducted output power and the maximum power spectral density shall be reduced by the amount in dB that the directional gain of the antenna exceeds 6 dBi.
3. For the band 5.725-5.85 GHz, the maximum conducted output power over the frequency band of operation shall not exceed 1 W. In addition, the maximum power spectral density shall not exceed 30 dBm in any 500-kHz band. If transmitting antennas of directional gain greater than 6 dBi are used, both the maximum conducted output power and the maximum power spectral density shall be reduced by the amount in dB that the directional gain of the antenna exceeds 6 dBi. However, fixed point-to-point U-NII devices operating in this band may employ transmitting antennas with directional gain greater than 6 dBi without any corresponding reduction in transmitter conducted power. Fixed, point-to-point operations exclude the use of point-to-multipoint systems, omnidirectional applications, and multiple collocated transmitters transmitting the same information. The operator of the U-NII device, or if the equipment is professionally installed, the installer, is responsible for ensuring that systems employing high gain directional antennas are used exclusively for fixed, point-to-point operations.

Shenzhen UnionTrust Quality and Technology Co., Ltd.

Address: Unit D/E of 9/F and 16/F, Block A, Building 6, Baoneng science and technology park, Longhua district, Shenzhen, China

Tel: +86-755-28230888

Fax: +86-755-28230886

E-mail: info@uttlab.com

<http://www.uttlab.com>

UTTR-RF-FCCPART15.407-V1.3

Test Procedure:

1. Connected the EUT's antenna port to measure device by 10dB attenuator.
2. Method PM is used to perform output power measurement, trigger and gating function of wide band power meter is enabled to measure max output power of Tx on burst.

Note: The cable loss and attenuator loss were offset into measure device as an amplitude offset.

Test Setup: Refer to section 4.5.3 for details.

Instruments Used: Refer to section 3 for details

Test Mode: Transmitter mode

Test Results: Pass

Test Data:

Gain and the maximum output power limit.

Frequency Band	Antenna Gain (dBi)	Power Limits (dBm)
U-NII-1	6.45	23.55
U-NII-2A	6.45	23.55
U-NII-2C	6.45	23.55
U-NII-3	6.45	29.55

For U-NII-2A :

For IEEE 802.11 a/n/ac/ax, the minimum 26 dB emission bandwidth is 24.81 MHz

$$11 \text{ dBm} + 10\log_{10}(24.81) = 24.95 \text{ dBm} > 24 \text{ dBm}$$

$$23.55 \text{ dBm} < 24 \text{ dBm} < 24.81 \text{ dBm}$$

So the 23.55 dBm limit applicable

For U-NII-2C Band:

For IEEE 802.11 a/n/ac/ax, the minimum 26 dB emission bandwidth is 26.97 MHz

$$11 \text{ dBm} + 10\log_{10}(26.97) = 25.31 \text{ dBm} > 24 \text{ dBm}$$

$$23.55 \text{ dBm} < 24 \text{ dBm} < 25.31 \text{ dBm}$$

So the 24 dBm limit applicable

Mode	Band	Channel	CONDUCTED AVG POWER			
			Meas Value (dBm)	Corr'd Value (dBm)	Limit (dBm)	Result
IEEE 802.11a	U-NII-1	36	15.97	16.22	23.55	Pass
		44	16.22	16.47	23.55	Pass
		48	16.18	16.43	23.55	Pass
	U-NII-2A	52	16.86	17.11	23.55	Pass
		60	16.77	17.02	23.55	Pass
		64	17.13	17.38	23.55	Pass
	U-NII-2C	100	20.04	20.29	23.55	Pass
		116	20.24	20.49	23.55	Pass
		120	20.15	20.40	23.55	Pass
		140	19.85	20.10	23.55	Pass
		144	20.12	20.37	23.55	Pass
	U-NII-3	144	20.12	20.37	29.55	Pass
		149	18.56	18.81	29.55	Pass
		157	18.28	18.53	29.55	Pass
		165	18.29	18.54	29.55	Pass
IEEE 802.11n-HT20	U-NII-1	36	15.54	15.64	23.55	Pass
		44	16.31	16.41	23.55	Pass
		48	16.44	16.54	23.55	Pass
	U-NII-2A	52	16.85	16.95	23.55	Pass
		60	17.27	17.37	23.55	Pass
		64	17.58	17.68	23.55	Pass
	U-NII-2C	100	20.35	20.45	23.55	Pass
		116	20.42	20.52	23.55	Pass
		120	20.37	20.47	23.55	Pass
		140	20.15	20.25	23.55	Pass
	U-NII-3	144	20.26	20.36	23.55	Pass
		149	18.62	18.72	29.55	Pass
		157	18.41	18.51	29.55	Pass
		165	18.45	18.55	29.55	Pass
	IEEE 802.11n-HT40	U-NII-1	38	16.41	16.52	23.55
46			16.38	16.49	23.55	Pass
U-NII-2A		54	16.87	16.98	23.55	Pass
		62	17.37	17.48	23.55	Pass
U-NII-2C		102	17.88	17.99	23.55	Pass
		110	18.16	18.27	23.55	Pass
		118	17.36	17.47	23.55	Pass
		134	16.34	16.45	23.55	Pass
U-NII-3		142	16.78	16.89	23.55	Pass
		142	16.78	16.89	29.55	Pass
		151	18.59	18.70	29.55	Pass
IEEE 802.11ac-VHT20	U-NII-1	36	15.59	15.98	23.55	Pass
		44	16.08	16.47	23.55	Pass
		48	16.16	16.55	23.55	Pass
	U-NII-2A	52	16.75	17.14	23.55	Pass
		60	17.27	17.66	23.55	Pass
		64	17.47	17.86	23.55	Pass
	U-NII-2C	100	20.11	20.50	23.55	Pass
116		20.10	20.49	23.55	Pass	
120		20.15	20.54	23.55	Pass	
140		19.38	19.77	23.55	Pass	
		144	20.08	20.47	23.55	Pass

Shenzhen UnionTrust Quality and Technology Co., Ltd.

	U-NII-3	144	20.08	20.47	29.55	Pass
		149	18.66	19.05	29.55	Pass
		157	18.85	19.24	29.55	Pass
		165	18.86	19.25	29.55	Pass
IEEE 802.11ac-VHT40	U-NII-1	38	16.34	16.45	23.55	Pass
		46	16.41	16.52	23.55	Pass
	U-NII-2A	54	16.83	16.94	23.55	Pass
		62	17.29	17.40	23.55	Pass
	U-NII-2C	102	20.38	20.49	23.55	Pass
		110	20.35	20.46	23.55	Pass
		118	20.36	20.47	23.55	Pass
		134	19.48	19.59	23.55	Pass
	U-NII-3	142	20.02	20.13	23.55	Pass
		142	20.02	20.13	29.55	Pass
		151	18.61	18.72	29.55	Pass
		159	18.78	18.89	29.55	Pass

Mode	Band	Channel	RU & Index	CONDUCTED AVG POWER			Result
				Meas Value (dBm)	Corr'd Value (dBm)	Limit (dBm)	
IEEE 802.11ax-HE20	U-NII-1	36	SU	16.88	17.05	23.55	Pass
		44	SU	16.93	17.10	23.55	Pass
		48	SU	17.28	17.45	23.55	Pass
	U-NII-2A	52	SU	16.47	16.64	23.55	Pass
		60	SU	17.03	17.20	23.55	Pass
		64	SU	17.21	17.38	23.55	Pass
	U-NII-2C	100	SU	21.05	21.22	23.55	Pass
		116	SU	20.31	20.48	23.55	Pass
		120	SU	20.53	20.70	23.55	Pass
		140	SU	19.81	19.98	23.55	Pass
	U-NII-3	144	SU	20.01	20.18	23.55	Pass
		144	SU	20.01	20.18	29.55	Pass
149		SU	18.28	18.45	29.55	Pass	
157		SU	18.63	18.80	29.55	Pass	
IEEE 802.11ax-HE40	U-NII-1	165	SU	18.64	18.81	29.55	Pass
		38	SU	16.62	16.75	23.55	Pass
	U-NII-2A	46	SU	16.95	17.08	23.55	Pass
		54	SU	16.51	16.64	23.55	Pass
	U-NII-2C	62	SU	17.01	17.14	23.55	Pass
		102	SU	18.45	18.58	23.55	Pass
		110	SU	19.15	19.28	23.55	Pass
		118	SU	18.27	18.40	23.55	Pass
U-NII-3	134	SU	17.46	17.59	23.55	Pass	
	142	SU	17.47	17.60	23.55	Pass	
	142	SU	17.47	17.60	29.55	Pass	
	151	SU	18.23	18.36	29.55	Pass	
		159	SU	18.41	18.54	29.55	Pass

Shenzhen UnionTrust Quality and Technology Co., Ltd.

5.6 PEAK POWER SPECTRAL DENSITY

Test Requirement: FCC 47 CFR Part 15 Subpart E Section 15.407 (a)(1)(2)(3)

Test Method: KDB 789033 D02 v02r01 Section F

Limits:

1. For the band 5.15-5.25 GHz.
 - (i) For an outdoor access point operating in the band 5.15-5.25 GHz, the maximum conducted output power over the frequency band of operation shall not exceed 1 W provided the maximum antenna gain does not exceed 6 dBi. In addition, the maximum power spectral density shall not exceed 17 dBm in any 1 megahertz band. If transmitting antennas of directional gain greater than 6 dBi are used, both the maximum conducted output power and the maximum power spectral density shall be reduced by the amount in dB that the directional gain of the antenna exceeds 6 dBi. The maximum e.i.r.p. at any elevation angle above 30 degrees as measured from the horizon must not exceed 125 mW (21 dBm).
 - (ii) For an indoor access point operating in the band 5.15-5.25 GHz, the maximum conducted output power over the frequency band of operation shall not exceed 1 W provided the maximum antenna gain does not exceed 6 dBi. In addition, the maximum power spectral density shall not exceed 17 dBm in any 1 megahertz band. If transmitting antennas of directional gain greater than 6 dBi are used, both the maximum conducted output power and the maximum power spectral density shall be reduced by the amount in dB that the directional gain of the antenna exceeds 6 dBi.
 - (iii) For fixed point-to-point access points operating in the band 5.15-5.25 GHz, the maximum conducted output power over the frequency band of operation shall not exceed 1 W. In addition, the maximum power spectral density shall not exceed 17 dBm in any 1 megahertz band. Fixed point-to-point U-NII devices may employ antennas with directional gain up to 23 dBi without any corresponding reduction in the maximum conducted output power or maximum power spectral density. For fixed point-to-point transmitters that employ a directional antenna gain greater than 23 dBi, a 1 dB reduction in maximum conducted output power and maximum power spectral density is required for each 1 dB of antenna gain in excess of 23 dBi. Fixed, point-to-point operations exclude the use of point-to-multipoint systems, omnidirectional applications, and multiple collocated transmitters transmitting the same information. The operator of the U-NII device, or if the equipment is professionally installed, the installer, is responsible for ensuring that systems employing high gain directional antennas are used exclusively for fixed, point-to-point operations.
 - (iv) For client devices in the 5.15-5.25 GHz band, the maximum conducted output power over the frequency band of operation shall not exceed 250 mW provided the maximum antenna gain does not exceed 6 dBi. In addition, the maximum power spectral density shall not exceed 11 dBm in any 1 megahertz band. If transmitting antennas of directional gain greater than 6 dBi are used, both the maximum conducted output power and the maximum power spectral density shall be reduced by the amount in dB that the directional gain of the antenna exceeds 6 dBi.
2. For the 5.25-5.35 GHz and 5.47-5.725 GHz bands, the maximum conducted output power over the frequency bands of operation shall not exceed the lesser of 250 mW or $11 \text{ dBm} + 10 \log B$, where B is the 26 dB emission bandwidth in megahertz. In addition, the maximum power spectral density shall not exceed 11 dBm in any 1 megahertz band. If transmitting antennas of directional gain greater than 6 dBi are used, both the maximum conducted output power and the maximum power spectral density shall be reduced by the amount in dB that the directional gain of the antenna exceeds 6 dBi.
3. For the band 5.725-5.85 GHz, the maximum conducted output power over the frequency band of operation shall not exceed 1 W. In addition, the maximum power spectral density shall not exceed 30 dBm in any 500-kHz band. If transmitting antennas of directional gain greater than 6 dBi are used, both the maximum conducted output power and the maximum power spectral density shall be reduced by the amount in dB that the directional gain of the antenna exceeds 6 dBi. However, fixed point-to-point U-NII devices operating in this band may employ transmitting antennas with directional gain greater than 6 dBi without any corresponding reduction in transmitter conducted power. Fixed, point-to-point operations exclude the use of point-to-multipoint systems, omnidirectional applications, and multiple collocated transmitters transmitting the same information. The operator of the U-NII device, or if the equipment is professionally installed, the installer, is responsible for ensuring that systems employing high gain directional antennas are used exclusively for fixed, point-to-point operations.

Shenzhen UnionTrust Quality and Technology Co., Ltd.

Address: Unit D/E of 9/F and 16/F, Block A, Building 6, Baoneng science and technology park, Longhua district, Shenzhen, China

Tel: +86-755-28230888

Fax: +86-755-28230886

E-mail: info@uttlab.com

<http://www.uttlab.com>

UTTR-RF-FCCPART15.407-V1.3

Test Procedure:

The output from the transmitter was connected to an attenuator and then to the input of the RF Spectrum Analyzer.

Spectrum analyzer according to the following Settings:

1. For U-NII-1, U-NII-2A, U-NII-2C band:

Using method SA-2

- a) Set span to encompass the entire emission bandwidth (EBW) of the signal.
- b) Set RBW = 1 MHz, Set VBW ≥ 3 RBW, Detector = RMS
- c) Sweep time = auto, trigger set to “free run”.
- d) Trace average at least 100 traces in power averaging mode.
- e) Record the max value and add 10 log (1/duty cycle)

2. For U-NII-3 band:

- a) Set span to encompass the entire emission bandwidth (EBW) of the signal.
- b) Set RBW = 500 kHz, Set VBW ≥ 3 RBW, Detector = RMS
- c) Use the peak marker function to determine the maximum power level in any 500 kHz band segment within the fundamental EBW.
- d) Sweep time = auto, trigger set to “free run”.
- e) Trace average at least 100 traces in power averaging mode.
- f) Record the max value and add 10 log (1/duty cycle)

Note: The cable loss and attenuator loss were offset into measure device as an amplitude offset.

Test Setup: Refer to section 4.5.3 for details.

Instruments Used: Refer to section 3 for details

Test Mode: Transmitter mode

Test Results: Pass

Test Data:

Gain and the maximum output power limit.

Frequency Band	Antenna Gain (dBi)	PSD Limits (dBm/MHz or dBm/500kHz)
U-NII-1	6.45	10.55
U-NII-2A	6.45	10.55
U-NII-2C	6.45	10.55
U-NII-3	6.45	29.55

5.7 RADIATED EMISSIONS AND BAND EDGE MEASUREMENT

Test Requirement: FCC 47 CFR Part 15 Subpart E Section 15.407 (b)(1)(2)(3)(4)(6)
 FCC 47 CFR Part 15 Subpart C Section 15.209/205

Test Method: KDB 789033 D02 v02r01 Section G.3, G.4, G.5, and G.6

Receiver Setup:

Frequency	RBW
0.009 MHz-0.150 MHz	200/300 kHz
0.150 MHz -30 MHz	9/10 kHz
30 MHz-1 GHz	100/120 kHz
Above 1 GHz	1 MHz

Limits:

1. Limits of Radiated Emission and Band edge Measurement

Radiated emissions that fall in the restricted bands must comply with the general emissions limits in 15.209(a) as below table. Other emissions shall be at least 20 dB below the highest level of the desired power.

Frequency	Field strength (microvolt/meter)	Limit (dB μ V/m)	Remark	Measurement distance (m)
0.009 MHz-0.490 MHz	2400/F(kHz)	--	--	300
0.490 MHz-1.705 MHz	24000/F(kHz)	--	--	30
1.705 MHz-30 MHz	30	--	--	30
30 MHz-88 MHz	100	40.0	Quasi-peak	3
88 MHz-216 MHz	150	43.5	Quasi-peak	3
216 MHz-960 MHz	200	46.0	Quasi-peak	3
960MHz-1GHz	500	54.0	Quasi-peak	3
Above 1 GHz	500	54.0	Average	3

Remark:

- a. The lower limit shall apply at the transition frequencies.
- b. Emission level (dB μ V/m) = 20 log Emission level (uV/m).
- c. For frequencies above 1000 MHz, the field strength limits are based on average detector, however, the peak field strength of any emission shall not exceed the maximum permitted average limits, specified above by more than 20 dB under any condition of modulation.

2. Limits of Unwanted Emission Out of the Restricted Bands

Applicable To	Limit	
789033 D02 General U-NII Test Procedures New Rules v01r04	Field Strength at 3 m	
	PK: 74 (dBμV/m)	AV: 54 (dBμV/m)
Applicable To	EIRP Limit	Equivalent Field Strength at 3 m
FCC Part 15.407 (b)(1)	PK: -27 (dBm/MHz)	PK: 74 (dBμV/m)
FCC Part 15.407 (b)(2)	PK: -27 (dBm/MHz)	PK: 74 (dBμV/m)
FCC Part 15.407 (b)(3)	PK: -27 (dBm/MHz)	PK: 68.2 (dBμV/m)
FCC Part 15.407 (b)(4)	27 dBm/MHz at frequencies from the band edges decreasing linearly to 15.6 dBm/MHz at 5 MHz above or below the band edges;	PK: 68.2 (dBμV/m)
	15.6 dBm/MHz at 5 MHz above or below the band edges decreasing linearly to 10 dBm/MHz at 25 MHz above or below the band edges;	
	10 dBm/MHz at 25 MHz above or below the band edges decreasing linearly to -27 dBm/MHz at 75 MHz above or below the band edges;	
	-27 dBm/MHz at frequencies more than 75 MHz above or below the band edges.	

Test Setup: Refer to section 4.5.1 for details.

Test Procedures:

- The EUT was placed on the top of a rotating table 0.8 meters (for below 1 GHz) / 1.5 meters (for above 1 GHz) above the ground at 3 meter chamber room for test. The table was rotated 360 degrees to determine the position of the highest radiation.
- The EUT was set 3 meters away from the interference-receiving antenna, which was mounted on the top of a variable-height antenna tower.
- The height of antenna is varied from one meter to four meters above the ground to determine the maximum value of the field strength. Both horizontal and vertical polarizations of the antenna are set to make the measurement.
- For each suspected emission, the EUT was arranged to its worst case and then the antenna was tuned to heights from 1 meter to 4 meters and the rotatable table was turned from 0 degrees to 360 degrees to find the maximum reading.
- The test-receiver system was set to quasi-peak detect function and specified bandwidth with maximum hold mode when the test frequency is below 1 GHz.
- The test-receiver system was set to peak and average detected function and specified bandwidth with maximum hold mode when the test frequency is above 1 GHz. If the peak reading value also meets average limit, measurement with the average detector is unnecessary.

Remark:

- The resolution bandwidth and video bandwidth of test receiver/spectrum analyzer is 120 kHz for Quasi-peak detection (QP) at frequency below 1 GHz.
- The resolution bandwidth of test receiver/spectrum analyzer is 1 MHz and the video bandwidth is 3 MHz for Peak detection (PK) at frequency above 1 GHz.
- The resolution bandwidth of test receiver/spectrum analyzer is 1 MHz and the video bandwidth is 3 MHz for RMS Average (Duty cycle < 98 %) for Average detection (AV) at frequency above 1 GHz, then the measurement results was added to a correction factor (10 log(1/duty cycle)).
- The resolution bandwidth of test receiver/spectrum analyzer is 1 MHz and the video bandwidth is 10 Hz (Duty cycle ≥ 98 %) or ≥ 1/T(duty cycle is < 98%) for Average detection (AV) at frequency above 1 GHz.
- All modes of operation were investigated and the worst-case emissions are reported.

Equipment Used: Refer to section 3 for details.

Test Result: Pass

The measurement data as follows:

Radiated Emission Test Data (9 KHz ~ 30 MHz):

The amplitude of spurious emissions attenuated more than 20 dB below the permissible value is not required to be report.

Radiated Emission Test Data (30 MHz ~ 1 GHz Worst Case):
Worst-Case Configuration (IEEE 802.11a Channel 36)

Horizontal

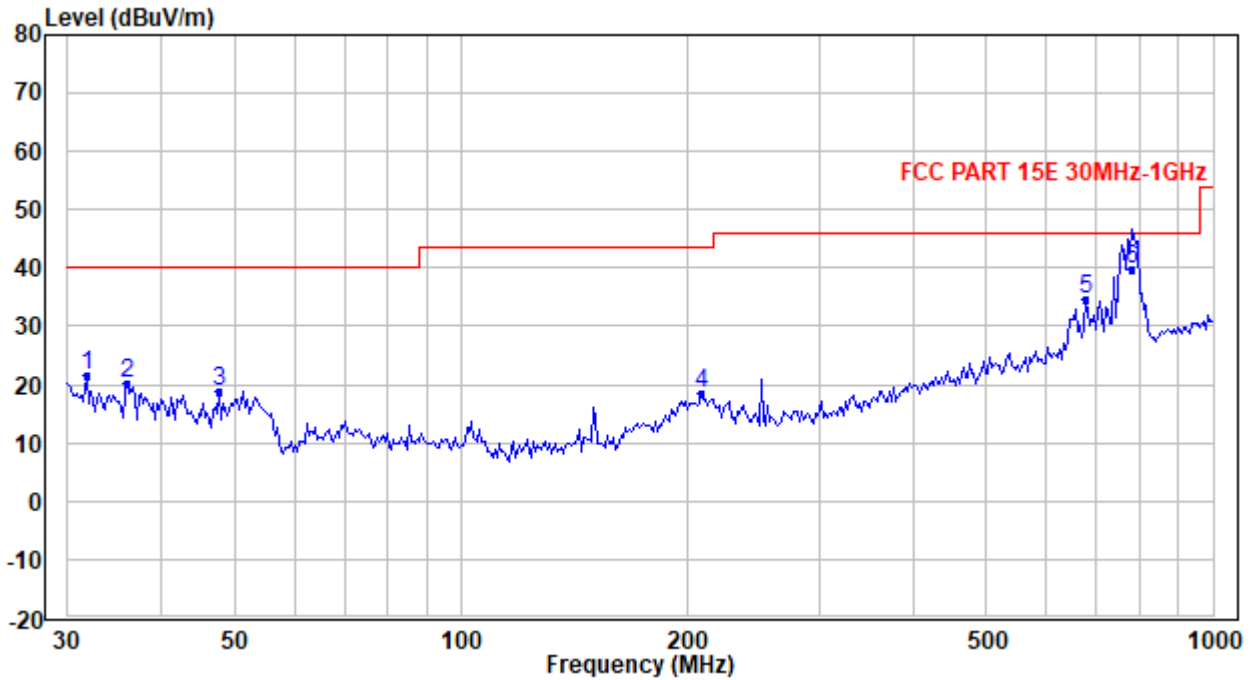

No.	Frequency (MHz)	Reading (dB μ V/m)	Correction factor (dB/m)	Result (dB μ V/m)	Limit (dB μ V/m)	Margin (dB)	Detector
1	31.735	27.61	-6.08	21.53	40.00	-18.47	QP
2	36.014	26.98	-6.72	20.26	40.00	-19.74	QP
3	47.703	31.94	-13.10	18.84	40.00	-21.16	QP
4	208.658	29.48	-10.99	18.49	43.50	-25.01	QP
5	679.435	33.69	0.96	34.65	46.00	-11.35	QP
6	781.961	37.16	2.48	39.64	46.00	-6.36	QP

Shenzhen UnionTrust Quality and Technology Co., Ltd.

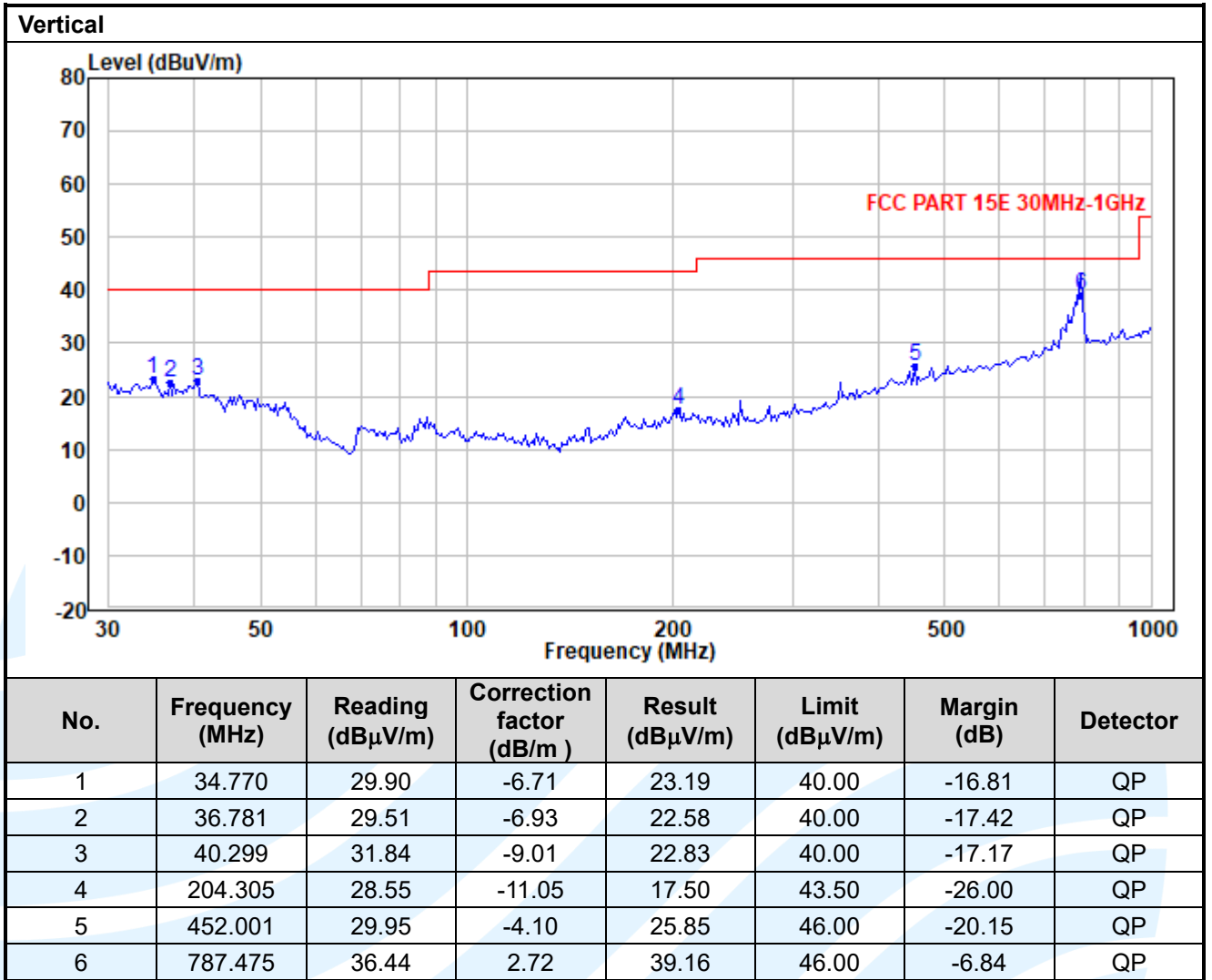

Shenzhen UnionTrust Quality and Technology Co., Ltd.

Address: Unit D/E of 9/F and 16/F, Block A, Building 6, Baoneng science and technology park, Longhua district, Shenzhen, China
 Tel: +86-755-28230888 Fax: +86-755-28230886 E-mail: info@uttlab.com <http://www.uttlab.com>
 UTR-RF-FCCPART15.407-V1.3

Radiated Emission Test Data (Above 1GHz): Worst-Case Configuration								
No.	Frequency (MHz)	Reading (dBµV)	Correction factor (dB/m)	Result (dBµV/m)	Limit (dBµV/m)	Margin (dB)	Detector	Antenna Polaxis
IEEE 802.11a_Channel 36								
1	10360.000	26.54	6.15	32.69	54	-21.31	Average	Horizontal
2	10360.000	41.99	6.15	48.14	68.2	-20.06	Peak	Horizontal
3	15540.000	22.70	11.11	33.81	54	-20.19	Average	Horizontal
4	15540.000	34.66	11.11	45.77	74	-28.23	Peak	Horizontal
5	10360.000	25.98	6.15	32.13	54	-21.87	Average	Vertical
6	10360.000	39.16	6.15	45.31	68.2	-22.89	Peak	Vertical
7	15540.000	22.80	11.11	33.91	54	-20.09	Average	Vertical
8	15540.000	35.18	11.11	46.29	74	-27.71	Peak	Vertical
IEEE 802.11a_Channel 44								
1	10440.000	28.24	6.03	34.27	54	-19.73	Average	Horizontal
2	10440.000	43.09	6.03	49.12	68.2	-19.08	Peak	Horizontal
3	15660.000	22.82	11.08	33.90	54	-20.10	Average	Horizontal
4	15660.000	35.34	11.08	46.42	74	-27.58	Peak	Horizontal
5	10440.000	27.10	6.03	33.13	54	-20.87	Average	Vertical
6	10440.000	40.32	6.03	46.35	68.2	-21.85	Peak	Vertical
7	15660.000	23.13	11.08	34.21	54	-19.79	Average	Vertical
8	15660.000	35.54	11.08	46.62	74	-27.38	Peak	Vertical
IEEE 802.11a_Channel 48								
1	10480.000	26.94	5.98	32.92	54	-21.08	Average	Horizontal
2	10480.000	42.69	5.98	48.67	68.2	-19.53	Peak	Horizontal
3	15720.000	22.59	11.08	33.67	54	-20.33	Average	Horizontal
4	15720.000	35.10	11.08	46.18	74	-27.82	Peak	Horizontal
5	10480.000	25.61	5.98	31.59	54	-22.41	Average	Vertical
6	10480.000	38.58	5.98	44.56	68.2	-23.64	Peak	Vertical
7	15720.000	22.59	11.08	33.67	54	-20.33	Average	Vertical
8	15720.000	34.79	11.08	45.87	74	-28.13	Peak	Vertical
IEEE 802.11a_Channel 52								
1	10520.000	28.37	5.92	34.29	54	-19.71	Average	Horizontal
2	10520.000	45.62	5.92	51.54	68.2	-16.66	Peak	Horizontal
3	15780.000	22.61	11.06	33.67	54	-20.33	Average	Horizontal
4	15780.000	39.27	11.06	50.33	74	-23.67	Peak	Horizontal
5	10520.000	26.67	5.92	32.59	54	-21.41	Average	Vertical
6	10520.000	41.82	5.92	47.74	68.2	-20.46	Peak	Vertical
7	15780.000	22.61	11.06	33.67	54	-20.33	Average	Vertical
8	15780.000	37.62	11.06	48.68	74	-25.32	Peak	Vertical

Shenzhen UnionTrust Quality and Technology Co., Ltd.

Address: Unit D/E of 9/F and 16/F, Block A, Building 6, Baoneng science and technology park, Longhua district, Shenzhen, China
 Tel: +86-755-28230888 Fax: +86-755-28230886 E-mail: info@uttlab.com <http://www.uttlab.com>
 UTTR-RF-FCCPART15.407-V1.3

No.	Frequency (MHz)	Reading (dBµV)	Correction factor (dB/m)	Result (dBµV/m)	Limit (dBµV/m)	Margin (dB)	Detector	Antenna Polaxis
IEEE 802.11a_Channel 60								
1	10600.000	28.04	5.82	33.86	54	-20.14	Average	Horizontal
2	10600.000	43.07	5.82	48.89	74	-25.11	Peak	Horizontal
3	15900.000	21.81	11.05	32.86	54	-21.14	Average	Horizontal
4	15900.000	34.20	11.05	45.25	74	-28.75	Peak	Horizontal
5	10600.000	26.55	5.82	32.37	54	-21.63	Average	Vertical
6	10600.000	41.93	5.82	47.75	74	-26.25	Peak	Vertical
7	15900.000	22.04	11.05	33.09	54	-20.91	Average	Vertical
8	15900.000	33.67	11.05	44.72	74	-29.28	Peak	Vertical
IEEE 802.11a_Channel 64								
1	10640.000	28.09	5.77	33.86	54	-20.14	Average	Horizontal
2	10640.000	45.30	5.77	51.07	74	-22.93	Peak	Horizontal
3	15960.000	22.06	11.03	33.09	54	-20.91	Average	Horizontal
4	15960.000	34.89	11.03	45.92	74	-28.08	Peak	Horizontal
5	10640.000	26.11	5.77	31.88	54	-22.12	Average	Vertical
6	10640.000	41.84	5.77	47.61	74	-26.39	Peak	Vertical
7	15960.000	21.95	11.03	32.98	54	-21.02	Average	Vertical
8	15960.000	35.33	11.03	46.36	74	-27.64	Peak	Vertical
IEEE 802.11a_Channel 100								
1	11000.000	34.64	5.32	39.96	54	-14.04	Average	Horizontal
2	11000.000	52.67	5.32	57.99	74	-16.01	Peak	Horizontal
3	16500.000	24.06	12.15	36.21	54	-17.79	Average	Horizontal
4	16500.000	42.57	12.15	54.72	68.2	-13.48	Peak	Horizontal
5	11000.000	33.38	5.32	38.70	54	-15.30	Average	Vertical
6	11000.000	51.39	5.32	56.71	74	-17.29	Peak	Vertical
7	16500.000	22.06	12.15	34.21	54	-19.79	Average	Vertical
8	16500.000	34.89	12.15	47.04	68.2	-21.16	Peak	Vertical
IEEE 802.11a_Channel 116								
1	11160.000	28.86	5.21	34.07	54	-19.93	Average	Horizontal
2	11160.000	49.63	5.21	54.84	74	-19.16	Peak	Horizontal
3	16740.000	23.73	12.55	36.28	54	-17.72	Average	Horizontal
4	16740.000	41.26	12.55	53.81	68.2	-14.39	Peak	Horizontal
5	11160.000	28.96	5.21	34.17	54	-19.83	Average	Vertical
6	11160.000	48.53	5.21	53.74	74	-20.26	Peak	Vertical
7	16740.000	22.20	12.55	34.75	54	-19.25	Average	Vertical
8	16740.000	35.51	12.55	48.06	68.2	-20.14	Peak	Vertical

Shenzhen UnionTrust Quality and Technology Co., Ltd.

Address: Unit D/E of 9/F and 16/F, Block A, Building 6, Baoneng science and technology park, Longhua district, Shenzhen, China
 Tel: +86-755-28230888 Fax: +86-755-28230886 E-mail: info@uttlab.com <http://www.uttlab.com>
 UTTR-RF-FCCPART15.407-V1.3

No.	Frequency (MHz)	Reading (dBµV)	Correction factor (dB/m)	Result (dBµV/m)	Limit (dBµV/m)	Margin (dB)	Detector	Antenna Polaxis
IEEE 802.11a_Channel 140								
1	11400.000	26.79	5.05	31.84	54	-22.16	Average	Horizontal
2	11400.000	40.70	5.05	45.75	74	-28.25	Peak	Horizontal
3	17100.000	21.41	13.34	34.75	54	-19.25	Average	Horizontal
4	17100.000	36.51	13.34	49.85	68.2	-18.35	Peak	Horizontal
5	11400.000	26.72	5.05	31.77	54	-22.23	Average	Vertical
6	11400.000	41.44	5.05	46.49	74	-27.51	Peak	Vertical
7	17100.000	21.41	13.34	34.75	54	-19.25	Average	Vertical
8	17100.000	34.16	13.34	47.50	68.2	-20.70	Peak	Vertical
IEEE 802.11a_Channel 144								
1	11440.000	38.71	5.03	43.74	54	-10.26	Peak	Horizontal
2	11440.000	24.51	5.03	29.54	74	-44.46	Average	Horizontal
3	17160.000	33.98	13.56	47.54	54	-6.46	Peak	Horizontal
4	17160.000	21.55	13.56	35.11	68.2	-33.09	Average	Horizontal
5	11440.000	24.84	5.03	29.87	54	-24.13	Average	Vertical
6	11440.000	39.38	5.03	44.41	74	-29.59	Peak	Vertical
7	17160.000	21.55	13.56	35.11	54	-18.89	Average	Vertical
8	17160.000	34.49	13.56	48.05	68.2	-20.15	Peak	Vertical
IEEE 802.11a_Channel 149								
1	11490.000	24.05	5.00	29.05	54	-24.95	Average	Horizontal
2	11490.000	37.61	5.00	42.61	74	-31.39	Peak	Horizontal
3	17235.000	21.39	13.84	35.23	54	-18.77	Average	Horizontal
4	17235.000	38.17	13.84	52.01	68.2	-16.19	Peak	Horizontal
5	11490.000	24.05	5.00	29.05	54	-24.95	Average	Vertical
6	11490.000	38.19	5.00	43.19	74	-30.81	Peak	Vertical
7	17235.000	21.39	13.84	35.23	54	-18.77	Average	Vertical
8	17235.000	36.00	13.84	49.84	68.2	-18.36	Peak	Vertical
IEEE 802.11a_Channel 157								
1	11570.000	24.43	4.95	29.38	54	-24.62	Average	Horizontal
2	11570.000	36.95	4.95	41.90	74	-32.10	Peak	Horizontal
3	17355.000	21.70	14.26	35.96	54	-18.04	Average	Horizontal
4	17355.000	38.83	14.26	53.09	68.2	-15.11	Peak	Horizontal
5	11570.000	24.68	4.95	29.63	54	-24.37	Average	Vertical
6	11570.000	37.63	4.95	42.58	74	-31.42	Peak	Vertical
7	17355.000	21.82	14.26	36.08	54	-17.92	Average	Vertical
8	17355.000	35.03	14.26	49.29	68.2	-18.91	Peak	Vertical

Shenzhen UnionTrust Quality and Technology Co., Ltd.

No.	Frequency (MHz)	Reading (dBµV)	Correction factor (dB/m)	Result (dBµV/m)	Limit (dBµV/m)	Margin (dB)	Detector	Antenna Polaxis
IEEE 802.11a_Channel 165								
1	11650.000	24.78	4.91	29.69	54	-24.31	Average	Horizontal
2	11650.000	37.42	4.91	42.33	74	-31.67	Peak	Horizontal
3	17475.000	21.26	14.70	35.96	54	-18.04	Average	Horizontal
4	17475.000	33.73	14.70	48.43	68.2	-19.77	Peak	Horizontal
5	11650.000	25.18	4.91	30.09	54	-23.91	Average	Vertical
6	11650.000	37.91	4.91	42.82	74	-31.18	Peak	Vertical
7	17475.000	21.26	14.70	35.96	54	-18.04	Average	Vertical
8	17475.000	34.17	14.70	48.87	68.2	-19.33	Peak	Vertical
IEEE 802.11n-HT20_Channel 36								
1	10360.000	26.13	6.15	32.28	54	-21.72	Average	Horizontal
2	10360.000	39.03	6.15	45.18	68.2	-23.02	Peak	Horizontal
3	15540.000	22.59	11.11	33.70	54	-20.30	Average	Horizontal
4	15540.000	34.74	11.11	45.85	74	-28.15	Peak	Horizontal
5	10360.000	25.61	6.15	31.76	54	-22.24	Average	Vertical
6	10360.000	38.13	6.15	44.28	68.2	-23.92	Peak	Vertical
7	15540.000	22.59	11.11	33.70	54	-20.30	Average	Vertical
8	15540.000	35.23	11.11	46.34	74	-27.66	Peak	Vertical
IEEE 802.11n-HT20_Channel 44								
1	10440.000	27.95	6.03	33.98	54	-20.02	Average	Horizontal
2	10440.000	41.98	6.03	48.01	68.2	-20.19	Peak	Horizontal
3	15660.000	22.71	11.08	33.79	54	-20.21	Average	Horizontal
4	15660.000	35.76	11.08	46.84	74	-27.16	Peak	Horizontal
5	10440.000	27.17	6.03	33.20	54	-20.80	Average	Vertical
6	10440.000	41.45	6.03	47.48	68.2	-20.72	Peak	Vertical
7	15660.000	22.82	11.08	33.90	54	-20.10	Average	Vertical
8	15660.000	34.97	11.08	46.05	74	-27.95	Peak	Vertical
IEEE 802.11n-HT20_Channel 48								
1	10480.000	26.33	5.98	32.31	54	-21.69	Average	Horizontal
2	10480.000	42.03	5.98	48.01	68.2	-20.19	Peak	Horizontal
3	15720.000	22.38	11.08	33.46	54	-20.54	Average	Horizontal
4	15720.000	34.90	11.08	45.98	74	-28.02	Peak	Horizontal
5	10480.000	25.53	5.98	31.51	54	-22.49	Average	Vertical
6	10480.000	38.96	5.98	44.94	68.2	-23.26	Peak	Vertical
7	15720.000	22.49	11.08	33.57	54	-20.43	Average	Vertical
8	15720.000	34.85	11.08	45.93	74	-28.07	Peak	Vertical

Shenzhen UnionTrust Quality and Technology Co., Ltd.

Address: Unit D/E of 9/F and 16/F, Block A, Building 6, Baoneng science and technology park, Longhua district, Shenzhen, China
 Tel: +86-755-28230888 Fax: +86-755-28230886 E-mail: info@uttlab.com <http://www.uttlab.com>
 UTTR-RF-FCCPART15.407-V1.3

No.	Frequency (MHz)	Reading (dBμV)	Correction factor (dB/m)	Result (dBμV/m)	Limit (dBμV/m)	Margin (dB)	Detector	Antenna Polaxis
IEEE 802.11n-HT20_Channel 52								
1	10520.000	28.32	5.92	34.24	54	-19.76	Average	Horizontal
2	10520.000	44.58	5.92	50.50	68.2	-17.70	Peak	Horizontal
3	15780.000	22.61	11.06	33.67	54	-20.33	Average	Horizontal
4	15780.000	35.64	11.06	46.70	74	-27.30	Peak	Horizontal
5	10520.000	26.53	5.92	32.45	54	-21.55	Average	Vertical
6	10520.000	41.78	5.92	47.70	68.2	-20.50	Peak	Vertical
7	15780.000	22.61	11.06	33.67	54	-20.33	Average	Vertical
8	15780.000	35.76	11.06	46.82	74	-27.18	Peak	Vertical
IEEE 802.11n-HT20_Channel 60								
1	10600.000	27.14	5.82	32.96	54	-21.04	Average	Horizontal
2	10600.000	43.87	5.82	49.69	74	-24.31	Peak	Horizontal
3	15900.000	21.93	11.05	32.98	54	-21.02	Average	Horizontal
4	15900.000	34.08	11.05	45.13	74	-28.87	Peak	Horizontal
5	10600.000	25.69	5.82	31.51	54	-22.49	Average	Vertical
6	10600.000	40.73	5.82	46.55	74	-27.45	Peak	Vertical
7	15900.000	21.93	11.05	32.98	54	-21.02	Average	Vertical
8	15900.000	34.66	11.05	45.71	74	-28.29	Peak	Vertical
IEEE 802.11n-HT20_Channel 64								
1	10640.000	26.66	5.77	32.43	54	-21.57	Average	Horizontal
2	10640.000	41.98	5.77	47.75	74	-26.25	Peak	Horizontal
3	15960.000	22.06	11.03	33.09	54	-20.91	Average	Horizontal
4	15960.000	34.71	11.03	45.74	74	-28.26	Peak	Horizontal
5	10640.000	39.00	5.77	44.77	54	-29.23	Peak	Vertical
6	15960.000	34.68	11.03	45.71	74	-28.29	Peak	Vertical
7	10640.000	25.36	5.77	31.13	54	-22.87	Average	Vertical
8	15960.000	21.95	11.03	32.98	74	-21.02	Average	Vertical
IEEE 802.11n-HT20_Channel 100								
1	11000.000	33.92	5.32	39.24	54	-14.76	Average	Horizontal
2	11000.000	49.38	5.32	54.70	74	-19.30	Peak	Horizontal
3	16500.000	21.94	12.15	34.09	54	-19.91	Average	Horizontal
4	16500.000	40.71	12.15	52.86	68.2	-15.34	Peak	Horizontal
5	11000.000	32.87	5.32	38.19	54	-15.81	Average	Vertical
6	11000.000	49.32	5.32	54.64	74	-19.36	Peak	Vertical
7	16500.000	21.94	12.15	34.09	54	-19.91	Average	Vertical
8	16500.000	34.46	12.15	46.61	68.2	-21.59	Peak	Vertical

Shenzhen UnionTrust Quality and Technology Co., Ltd.

Address: Unit D/E of 9/F and 16/F, Block A, Building 6, Baoneng science and technology park, Longhua district, Shenzhen, China
 Tel: +86-755-28230888 Fax: +86-755-28230886 E-mail: info@uttlab.com <http://www.uttlab.com>
 UTTR-RF-FCCPART15.407-V1.3

No.	Frequency (MHz)	Reading (dBμV)	Correction factor (dB/m)	Result (dBμV/m)	Limit (dBμV/m)	Margin (dB)	Detector	Antenna Polaxis
IEEE 802.11n-HT20_Channel 116								
1	11160.000	28.49	5.21	33.70	54	-20.30	Average	Horizontal
2	11160.000	47.47	5.21	52.68	74	-21.32	Peak	Horizontal
3	16740.000	23.05	12.55	35.60	54	-18.40	Average	Horizontal
4	16740.000	40.71	12.55	53.26	68.2	-14.94	Peak	Horizontal
5	11160.000	28.75	5.21	33.96	54	-20.04	Average	Vertical
6	11160.000	48.38	5.21	53.59	74	-20.41	Peak	Vertical
7	16740.000	21.98	12.55	34.53	54	-19.47	Average	Vertical
8	16740.000	36.25	12.55	48.80	68.2	-19.40	Peak	Vertical
IEEE 802.11n-HT20_Channel 140								
1	11400.000	26.52	5.05	31.57	54	-22.43	Average	Horizontal
2	11400.000	41.03	5.05	46.08	74	-27.92	Peak	Horizontal
3	17100.000	21.29	13.34	34.63	54	-19.37	Average	Horizontal
4	17100.000	34.46	13.34	47.80	68.2	-20.40	Peak	Horizontal
5	11400.000	26.72	5.05	31.77	54	-22.23	Average	Vertical
6	11400.000	41.39	5.05	46.44	74	-27.56	Peak	Vertical
7	17100.000	21.41	13.34	34.75	54	-19.25	Average	Vertical
8	17100.000	34.70	13.34	48.04	68.2	-20.16	Peak	Vertical
IEEE 802.11n-HT20_Channel 144								
1	11440.000	24.59	5.03	29.62	54	-24.38	Average	Horizontal
2	11440.000	37.39	5.03	42.42	74	-31.58	Peak	Horizontal
3	17160.000	21.43	13.56	34.99	54	-19.01	Average	Horizontal
4	17160.000	37.06	13.56	50.62	68.2	-17.58	Peak	Horizontal
5	11440.000	24.92	5.03	29.95	54	-24.05	Average	Vertical
6	11440.000	38.47	5.03	43.50	74	-30.50	Peak	Vertical
7	17160.000	21.55	13.56	35.11	54	-18.89	Average	Vertical
8	17160.000	34.68	13.56	48.24	68.2	-19.96	Peak	Vertical
IEEE 802.11n-HT20_Channel 149								
1	11490.000	24.14	5.00	29.14	54	-24.86	Average	Horizontal
2	11490.000	36.94	5.00	41.94	74	-32.06	Peak	Horizontal
3	17235.000	21.26	13.84	35.10	54	-18.90	Average	Horizontal
4	17235.000	37.46	13.84	51.30	68.2	-16.90	Peak	Horizontal
5	11490.000	24.23	5.00	29.23	54	-24.77	Average	Vertical
6	11490.000	38.32	5.00	43.32	74	-30.68	Peak	Vertical
7	17235.000	21.39	13.84	35.23	54	-18.77	Average	Vertical
8	17235.000	33.89	13.84	47.73	68.2	-20.47	Peak	Vertical

Shenzhen UnionTrust Quality and Technology Co., Ltd.

Address: Unit D/E of 9/F and 16/F, Block A, Building 6, Baoneng science and technology park, Longhua district, Shenzhen, China
 Tel: +86-755-28230888 Fax: +86-755-28230886 E-mail: info@uttlab.com <http://www.uttlab.com>
 UTTR-RF-FCCPART15.407-V1.3

No.	Frequency (MHz)	Reading (dBµV)	Correction factor (dB/m)	Result (dBµV/m)	Limit (dBµV/m)	Margin (dB)	Detector	Antenna Polaxis
IEEE 802.11n-HT20_Channel 157								
1	11570.000	24.51	4.95	29.46	54	-24.54	Average	Horizontal
2	11570.000	37.08	4.95	42.03	74	-31.97	Peak	Horizontal
3	17355.000	21.58	14.26	35.84	54	-18.16	Average	Horizontal
4	17355.000	38.56	14.26	52.82	68.2	-15.38	Peak	Horizontal
5	11570.000	25.33	4.95	30.28	54	-23.72	Average	Vertical
6	11570.000	38.35	4.95	43.30	74	-30.70	Peak	Vertical
7	17355.000	21.70	14.26	35.96	54	-18.04	Average	Vertical
8	17355.000	33.86	14.26	48.12	68.2	-20.08	Peak	Vertical
IEEE 802.11n-HT20_Channel 165								
1	11650.000	24.86	4.91	29.77	54	-24.23	Average	Horizontal
2	11650.000	37.36	4.91	42.27	74	-31.73	Peak	Horizontal
3	17475.000	21.13	14.70	35.83	54	-18.17	Average	Horizontal
4	17475.000	33.67	14.70	48.37	68.2	-19.83	Peak	Horizontal
5	11650.000	25.02	4.91	29.93	54	-24.07	Average	Vertical
6	11650.000	37.17	4.91	42.08	74	-31.92	Peak	Vertical
7	17475.000	21.26	14.70	35.96	54	-18.04	Average	Vertical
8	17475.000	34.17	14.70	48.87	68.2	-19.33	Peak	Vertical
IEEE 802.11n-HT40_Channel 38								
1	10380.000	26.97	6.12	33.09	54	-20.91	Average	Horizontal
2	10380.000	38.02	6.12	44.14	68.2	-24.06	Peak	Horizontal
3	15570.000	22.49	11.10	33.59	54	-20.41	Average	Horizontal
4	15570.000	34.91	11.10	46.01	74	-27.99	Peak	Horizontal
5	10380.000	26.09	6.12	32.21	54	-21.79	Average	Vertical
6	10380.000	37.59	6.12	43.71	68.2	-24.49	Peak	Vertical
7	15570.000	22.49	11.10	33.59	54	-20.41	Average	Vertical
8	15570.000	34.62	11.10	45.72	74	-28.28	Peak	Vertical
IEEE 802.11n-HT40_Channel 46								
1	10460.000	27.80	6.01	33.81	54	-20.19	Average	Horizontal
2	10460.000	40.78	6.01	46.79	68.2	-21.41	Peak	Horizontal
3	15690.000	22.82	11.08	33.90	54	-20.10	Average	Horizontal
4	15690.000	34.99	11.08	46.07	74	-27.93	Peak	Horizontal
5	10460.000	26.93	6.01	32.94	54	-21.06	Average	Vertical
6	10460.000	40.27	6.01	46.28	68.2	-21.92	Peak	Vertical
7	15690.000	22.82	11.08	33.90	54	-20.10	Average	Vertical
8	15690.000	35.37	11.08	46.45	74	-27.55	Peak	Vertical

Shenzhen UnionTrust Quality and Technology Co., Ltd.

Address: Unit D/E of 9/F and 16/F, Block A, Building 6, Baoneng science and technology park, Longhua district, Shenzhen, China
 Tel: +86-755-28230888 Fax: +86-755-28230886 E-mail: info@uttlab.com <http://www.uttlab.com>
 UTTR-RF-FCCPART15.407-V1.3

No.	Frequency (MHz)	Reading (dBµV)	Correction factor (dB/m)	Result (dBµV/m)	Limit (dBµV/m)	Margin (dB)	Detector	Antenna Polaxis
IEEE 802.11n-HT40_Channel 54								
1	10540.000	28.22	5.89	34.11	54	-19.89	Average	Horizontal
2	10540.000	43.22	5.89	49.11	68.2	-19.09	Peak	Horizontal
3	15810.000	22.16	11.06	33.22	54	-20.78	Average	Horizontal
4	15810.000	34.93	11.06	45.99	74	-28.01	Peak	Horizontal
5	10540.000	26.14	5.89	32.03	54	-21.97	Average	Vertical
6	10540.000	39.39	5.89	45.28	68.2	-22.92	Peak	Vertical
7	15810.000	22.16	11.06	33.22	54	-20.78	Average	Vertical
8	15810.000	34.64	11.06	45.70	74	-28.30	Peak	Vertical
IEEE 802.11n-HT40_Channel 62								
1	10620.000	27.35	5.80	33.15	54	-20.85	Average	Horizontal
2	10620.000	41.31	5.80	47.11	74	-26.89	Peak	Horizontal
3	15930.000	21.94	11.04	32.98	54	-21.02	Average	Horizontal
4	15930.000	35.17	11.04	46.21	74	-27.79	Peak	Horizontal
5	10620.000	26.15	5.80	31.95	54	-22.05	Average	Vertical
6	10620.000	37.66	5.80	43.46	74	-30.54	Peak	Vertical
7	15930.000	21.94	11.04	32.98	54	-21.02	Average	Vertical
8	15930.000	34.32	11.04	45.36	74	-28.64	Peak	Vertical
IEEE 802.11n-HT40_Channel 102								
1	11020.000	32.45	5.30	37.75	54	-16.25	Average	Horizontal
2	11020.000	48.82	5.30	54.12	74	-19.88	Peak	Horizontal
3	16530.000	23.27	12.21	35.48	54	-18.52	Average	Horizontal
4	16530.000	39.52	12.21	51.73	68.2	-16.47	Peak	Horizontal
5	11020.000	30.81	5.30	36.11	54	-17.89	Average	Vertical
6	11020.000	46.55	5.30	51.85	74	-22.15	Peak	Vertical
7	16530.000	22.22	12.21	34.43	54	-19.57	Average	Vertical
8	16530.000	35.68	12.21	47.89	68.2	-20.31	Peak	Vertical
IEEE 802.11n-HT40_Channel 110								
1	11100.000	29.62	5.25	34.87	54	-19.13	Average	Horizontal
2	11100.000	44.90	5.25	50.15	74	-23.85	Peak	Horizontal
3	16650.000	21.66	12.40	34.06	54	-19.94	Average	Horizontal
4	16650.000	36.79	12.40	49.19	68.2	-19.01	Peak	Horizontal
5	11100.000	29.28	5.25	34.53	54	-19.47	Average	Vertical
6	11100.000	45.10	5.25	50.35	74	-23.65	Peak	Vertical
7	16650.000	21.78	12.40	34.18	54	-19.82	Average	Vertical
8	16650.000	33.91	12.40	46.31	68.2	-21.89	Peak	Vertical

Shenzhen UnionTrust Quality and Technology Co., Ltd.

No.	Frequency (MHz)	Reading (dBµV)	Correction factor (dB/m)	Result (dBµV/m)	Limit (dBµV/m)	Margin (dB)	Detector	Antenna Polaxis
IEEE 802.11n-HT40_Channel 134								
1	11340.000	26.09	5.10	31.19	54	-22.81	Average	Horizontal
2	11340.000	38.38	5.10	43.48	74	-30.52	Peak	Horizontal
3	17010.000	21.52	13.02	34.54	54	-19.46	Average	Horizontal
4	17010.000	33.97	13.02	46.99	68.2	-21.21	Peak	Horizontal
5	11340.000	26.02	5.10	31.12	54	-22.88	Average	Vertical
6	11340.000	38.66	5.10	43.76	74	-30.24	Peak	Vertical
7	17010.000	21.52	13.02	34.54	54	-19.46	Average	Vertical
8	17010.000	33.92	13.02	46.94	68.2	-21.26	Peak	Vertical
IEEE 802.11n-HT40_Channel 142								
1	11420.000	25.96	5.04	31.00	54	-23.00	Average	Horizontal
2	11420.000	41.67	5.04	46.71	74	-27.29	Peak	Horizontal
3	17130.000	22.34	13.45	35.79	54	-18.21	Average	Horizontal
4	17130.000	36.53	13.45	49.98	68.2	-18.22	Peak	Horizontal
5	11420.000	25.74	5.04	30.78	54	-23.22	Average	Vertical
6	11420.000	38.99	5.04	44.03	74	-29.97	Peak	Vertical
7	17130.000	22.01	13.45	35.46	54	-18.54	Average	Vertical
8	17130.000	34.24	13.45	47.69	68.2	-20.51	Peak	Vertical
IEEE 802.11n-HT40_Channel 151								
1	11510.000	26.16	4.98	31.14	54	-22.86	Average	Horizontal
2	11510.000	38.23	4.98	43.21	74	-30.79	Peak	Horizontal
3	17265.000	21.53	13.94	35.47	54	-18.53	Average	Horizontal
4	17265.000	37.67	13.94	51.61	68.2	-16.59	Peak	Horizontal
5	11510.000	26.44	4.98	31.42	54	-22.58	Average	Vertical
6	11510.000	41.37	4.98	46.35	74	-27.65	Peak	Vertical
7	17265.000	21.53	13.94	35.47	54	-18.53	Average	Vertical
8	17265.000	33.90	13.94	47.84	68.2	-20.36	Peak	Vertical
IEEE 802.11n-HT40_Channel 159								
1	11590.000	25.19	4.94	30.13	54	-23.87	Average	Horizontal
2	11590.000	37.81	4.94	42.75	74	-31.25	Peak	Horizontal
3	17385.000	21.71	14.37	36.08	54	-17.92	Average	Horizontal
4	17385.000	33.99	14.37	48.36	68.2	-19.84	Peak	Horizontal
5	11590.000	25.42	4.94	30.36	54	-23.64	Average	Vertical
6	11590.000	37.86	4.94	42.80	74	-31.20	Peak	Vertical
7	17385.000	21.83	14.37	36.20	54	-17.80	Average	Vertical
8	17385.000	33.96	14.37	48.33	68.2	-19.87	Peak	Vertical

Shenzhen UnionTrust Quality and Technology Co., Ltd.

Address: Unit D/E of 9/F and 16/F, Block A, Building 6, Baoneng science and technology park, Longhua district, Shenzhen, China
 Tel: +86-755-28230888 Fax: +86-755-28230886 E-mail: info@uttlab.com <http://www.uttlab.com>
 UTTR-RF-FCCPART15.407-V1.3

Radiated Emission Test Data (Above 1GHz): Worst-Case Configuration								
No.	Frequency (MHz)	Reading (dBµV)	Correction factor (dB/m)	Result (dBµV/m)	Limit (dBµV/m)	Margin (dB)	Detector	Antenna Polaxis
IEEE 802.11ax-HE20_Channel 36								
1	10360.000	26.48	6.15	32.63	54	-21.37	Average	Horizontal
2	10360.000	40.14	6.15	46.29	68.2	-21.91	Peak	Horizontal
3	15540.000	22.70	11.11	33.81	54	-20.19	Average	Horizontal
4	15540.000	36.33	11.11	47.44	74	-26.56	Peak	Horizontal
5	10360.000	26.06	6.15	32.21	54	-21.79	Average	Vertical
6	10360.000	39.36	6.15	45.51	68.2	-22.69	Peak	Vertical
7	15540.000	22.70	11.11	33.81	54	-20.19	Average	Vertical
8	15540.000	34.08	11.11	45.19	74	-28.81	Peak	Vertical
IEEE 802.11ax-HE20_Channel 44								
1	10440.000	28.07	6.03	34.10	54	-19.90	Average	Horizontal
2	10440.000	42.59	6.03	48.62	68.2	-19.58	Peak	Horizontal
3	15660.000	22.71	11.08	33.79	54	-20.21	Average	Horizontal
4	15660.000	35.39	11.08	46.47	74	-27.53	Peak	Horizontal
5	10440.000	27.29	6.03	33.32	54	-20.68	Average	Vertical
6	10440.000	40.94	6.03	46.97	68.2	-21.23	Peak	Vertical
7	15660.000	22.71	11.08	33.79	54	-20.21	Average	Vertical
8	15660.000	34.27	11.08	45.35	74	-28.65	Peak	Vertical
IEEE 802.11ax-HE20_Channel 48								
1	10480.000	26.12	5.98	32.10	54	-21.90	Average	Horizontal
2	10480.000	41.55	5.98	47.53	68.2	-20.67	Peak	Horizontal
3	15720.000	22.38	11.08	33.46	54	-20.54	Average	Horizontal
4	15720.000	34.63	11.08	45.71	74	-28.29	Peak	Horizontal
5	10480.000	25.68	5.98	31.66	54	-22.34	Average	Vertical
6	10480.000	38.83	5.98	44.81	68.2	-23.39	Peak	Vertical
7	15720.000	22.27	11.08	33.35	54	-20.65	Average	Vertical
8	15720.000	34.50	11.08	45.58	74	-28.42	Peak	Vertical
IEEE 802.11ax-HE20_Channel 52								
1	10520.000	28.04	5.92	33.96	54	-20.04	Average	Horizontal
2	10520.000	46.50	5.92	52.42	68.2	-15.78	Peak	Horizontal
3	15780.000	22.61	11.06	33.67	54	-20.33	Average	Horizontal
4	15780.000	36.44	11.06	47.50	74	-26.50	Peak	Horizontal
5	10520.000	27.19	5.92	33.11	54	-20.89	Average	Vertical
6	10520.000	42.75	5.92	48.67	68.2	-19.53	Peak	Vertical
7	15780.000	22.40	11.06	33.46	54	-20.54	Average	Vertical
8	15780.000	37.60	11.06	48.66	74	-25.34	Peak	Vertical

Shenzhen UnionTrust Quality and Technology Co., Ltd.

Address: Unit D/E of 9/F and 16/F, Block A, Building 6, Baoneng science and technology park, Longhua district, Shenzhen, China
 Tel: +86-755-28230888 Fax: +86-755-28230886 E-mail: info@uttlab.com <http://www.uttlab.com>
 UTTR-RF-FCCPART15.407-V1.3

No.	Frequency (MHz)	Reading (dBµV)	Correction factor (dB/m)	Result (dBµV/m)	Limit (dBµV/m)	Margin (dB)	Detector	Antenna Polaxis
IEEE 802.11ax-HE20_Channel 60								
1	10600.000	27.81	5.82	33.63	54	-20.37	Average	Horizontal
2	10600.000	44.88	5.82	50.70	74	-23.30	Peak	Horizontal
3	15900.000	21.81	11.05	32.86	54	-21.14	Average	Horizontal
4	15900.000	34.42	11.05	45.47	74	-28.53	Peak	Horizontal
5	10600.000	26.34	5.82	32.16	54	-21.84	Average	Vertical
6	10600.000	42.13	5.82	47.95	74	-26.05	Peak	Vertical
7	15900.000	21.81	11.05	32.86	54	-21.14	Average	Vertical
8	15900.000	33.82	11.05	44.87	74	-29.13	Peak	Vertical
IEEE 802.11ax-HE20_Channel 64								
1	10640.000	27.31	5.77	33.08	54	-20.92	Average	Horizontal
2	10640.000	43.89	5.77	49.66	74	-24.34	Peak	Horizontal
3	15960.000	21.95	11.03	32.98	54	-21.02	Average	Horizontal
4	15960.000	36.18	11.03	47.21	74	-26.79	Peak	Horizontal
5	10640.000	25.82	5.77	31.59	54	-22.41	Average	Vertical
6	10640.000	41.10	5.77	46.87	74	-27.13	Peak	Vertical
7	15960.000	21.95	11.03	32.98	54	-21.02	Average	Vertical
8	15960.000	34.81	11.03	45.84	74	-28.16	Peak	Vertical
IEEE 802.11ax-HE20_Channel 100								
1	11000.000	35.58	5.32	40.90	54	-13.10	Average	Horizontal
2	11000.000	51.33	5.32	56.65	74	-17.35	Peak	Horizontal
3	16500.000	23.71	12.15	35.86	54	-18.14	Average	Horizontal
4	16500.000	40.99	12.15	53.14	68.2	-15.06	Peak	Horizontal
5	11000.000	34.80	5.32	40.12	54	-13.88	Average	Vertical
6	11000.000	51.25	5.32	56.57	74	-17.43	Peak	Vertical
7	16500.000	21.83	12.15	33.98	54	-20.02	Average	Vertical
8	16500.000	36.68	12.15	48.83	68.2	-19.37	Peak	Vertical
IEEE 802.11ax-HE20_Channel 116								
1	11160.000	30.39	5.21	35.60	54	-18.40	Average	Horizontal
2	11160.000	51.49	5.21	56.70	74	-17.30	Peak	Horizontal
3	16740.000	22.85	12.55	35.40	54	-18.60	Average	Horizontal
4	16740.000	39.43	12.55	51.98	68.2	-16.22	Peak	Horizontal
5	11160.000	30.30	5.21	35.51	54	-18.49	Average	Vertical
6	11160.000	51.15	5.21	56.36	74	-17.64	Peak	Vertical
7	16740.000	21.98	12.55	34.53	54	-19.47	Average	Vertical
8	16740.000	37.37	12.55	49.92	68.2	-18.28	Peak	Vertical

Shenzhen UnionTrust Quality and Technology Co., Ltd.

Address: Unit D/E of 9/F and 16/F, Block A, Building 6, Baoneng science and technology park, Longhua district, Shenzhen, China
 Tel: +86-755-28230888 Fax: +86-755-28230886 E-mail: info@uttlab.com <http://www.uttlab.com>
 UTTR-RF-FCCPART15.407-V1.3

No.	Frequency (MHz)	Reading (dBµV)	Correction factor (dB/m)	Result (dBµV/m)	Limit (dBµV/m)	Margin (dB)	Detector	Antenna Polaxis
IEEE 802.11ax-HE20_Channel 140								
1	11400.000	27.11	5.05	32.16	54	-21.84	Average	Horizontal
2	11400.000	41.97	5.05	47.02	74	-26.98	Peak	Horizontal
3	17100.000	20.91	13.34	34.25	54	-19.75	Average	Horizontal
4	17100.000	32.95	13.34	46.29	68.2	-21.91	Peak	Horizontal
5	11400.000	27.30	5.05	32.35	54	-21.65	Average	Vertical
6	11400.000	40.90	5.05	45.95	74	-28.05	Peak	Vertical
7	17100.000	21.16	13.34	34.50	54	-19.50	Average	Vertical
8	17100.000	33.90	13.34	47.24	68.2	-20.96	Peak	Vertical
IEEE 802.11ax-HE20_Channel 144								
1	11440.000	24.76	5.03	29.79	54	-24.21	Average	Horizontal
2	11440.000	39.75	5.03	44.78	74	-29.22	Peak	Horizontal
3	17160.000	21.18	13.56	34.74	54	-19.26	Average	Horizontal
4	17160.000	36.76	13.56	50.32	68.2	-17.88	Peak	Horizontal
5	11440.000	25.40	5.03	30.43	54	-23.57	Average	Vertical
6	11440.000	39.92	5.03	44.95	74	-29.05	Peak	Vertical
7	17160.000	21.30	13.56	34.86	54	-19.14	Average	Vertical
8	17160.000	34.92	13.56	48.48	68.2	-19.72	Peak	Vertical
IEEE 802.11ax-HE20_Channel 149								
1	11490.000	24.23	5.00	29.23	54	-24.77	Average	Horizontal
2	11490.000	40.07	5.00	45.07	74	-28.93	Peak	Horizontal
3	17235.000	21.00	13.84	34.84	54	-19.16	Average	Horizontal
4	17235.000	38.20	13.84	52.04	68.2	-16.16	Peak	Horizontal
5	11490.000	24.50	5.00	29.50	54	-24.50	Average	Vertical
6	11490.000	39.54	5.00	44.54	74	-29.46	Peak	Vertical
7	17235.000	21.13	13.84	34.97	54	-19.03	Average	Vertical
8	17235.000	34.00	13.84	47.84	68.2	-20.36	Peak	Vertical
IEEE 802.11ax-HE20_Channel 157								
1	11570.000	24.85	4.95	29.80	54	-24.20	Average	Horizontal
2	11570.000	36.51	4.95	41.46	74	-32.54	Peak	Horizontal
3	17355.000	21.45	14.26	35.71	54	-18.29	Average	Horizontal
4	17355.000	38.21	14.26	52.47	68.2	-15.73	Peak	Horizontal
5	11570.000	25.26	4.95	30.21	54	-23.79	Average	Vertical
6	11570.000	37.76	4.95	42.71	74	-31.29	Peak	Vertical
7	17355.000	21.58	14.26	35.84	54	-18.16	Average	Vertical
8	17355.000	33.56	14.26	47.82	68.2	-20.38	Peak	Vertical

Shenzhen UnionTrust Quality and Technology Co., Ltd.

Address: Unit D/E of 9/F and 16/F, Block A, Building 6, Baoneng science and technology park, Longhua district, Shenzhen, China
 Tel: +86-755-28230888 Fax: +86-755-28230886 E-mail: info@uttlab.com <http://www.uttlab.com>
 UTTR-RF-FCCPART15.407-V1.3

No.	Frequency (MHz)	Reading (dBµV)	Correction factor (dB/m)	Result (dBµV/m)	Limit (dBµV/m)	Margin (dB)	Detector	Antenna Polaxis
IEEE 802.11ax-HE20_Channel 165								
1	11650.000	24.86	4.91	29.77	54	-24.23	Average	Horizontal
2	11650.000	36.69	4.91	41.60	74	-32.40	Peak	Horizontal
3	17475.000	21.00	14.70	35.70	54	-18.30	Average	Horizontal
4	17475.000	37.01	14.70	51.71	68.2	-16.49	Peak	Horizontal
5	11650.000	24.94	4.91	29.85	54	-24.15	Average	Vertical
6	11650.000	37.84	4.91	42.75	74	-31.25	Peak	Vertical
7	17475.000	21.00	14.70	35.70	54	-18.30	Average	Vertical
8	17475.000	33.52	14.70	48.22	68.2	-19.98	Peak	Vertical
IEEE 802.11ax-HE40_Channel 38								
1	10380.000	25.02	6.12	31.14	54	-22.86	Average	Horizontal
2	10380.000	37.28	6.12	43.40	68.2	-24.80	Peak	Horizontal
3	15570.000	22.49	11.10	33.59	54	-20.41	Average	Horizontal
4	15570.000	35.75	11.10	46.85	74	-27.15	Peak	Horizontal
5	10380.000	25.10	6.12	31.22	54	-22.78	Average	Vertical
6	10380.000	37.76	6.12	43.88	68.2	-24.32	Peak	Vertical
7	15570.000	22.49	11.10	33.59	54	-20.41	Average	Vertical
8	15570.000	34.45	11.10	45.55	74	-28.45	Peak	Vertical
IEEE 802.11ax-HE40_Channel 46								
1	10460.000	27.50	6.01	33.51	54	-20.49	Average	Horizontal
2	10460.000	38.45	6.01	44.46	68.2	-23.74	Peak	Horizontal
3	15690.000	22.82	11.08	33.90	54	-20.10	Average	Horizontal
4	15690.000	35.09	11.08	46.17	74	-27.83	Peak	Horizontal
5	10460.000	26.99	6.01	33.00	54	-21.00	Average	Vertical
6	10460.000	39.39	6.01	45.40	68.2	-22.80	Peak	Vertical
7	15690.000	22.71	11.08	33.79	54	-20.21	Average	Vertical
8	15690.000	35.49	11.08	46.57	74	-27.43	Peak	Vertical
IEEE 802.11ax-HE40_Channel 54								
1	10540.000	28.05	5.89	33.94	54	-20.06	Average	Horizontal
2	10540.000	41.02	5.89	46.91	68.2	-21.29	Peak	Horizontal
3	15810.000	22.05	11.06	33.11	54	-20.89	Average	Horizontal
4	15810.000	34.09	11.06	45.15	74	-28.85	Peak	Horizontal
5	10540.000	26.89	5.89	32.78	54	-21.22	Average	Vertical
6	10540.000	41.01	5.89	46.90	68.2	-21.30	Peak	Vertical
7	15810.000	22.05	11.06	33.11	54	-20.89	Average	Vertical
8	15810.000	34.26	11.06	45.32	74	-28.68	Peak	Vertical

Shenzhen UnionTrust Quality and Technology Co., Ltd.

Address: Unit D/E of 9/F and 16/F, Block A, Building 6, Baoneng science and technology park, Longhua district, Shenzhen, China
 Tel: +86-755-28230888 Fax: +86-755-28230886 E-mail: info@uttlab.com <http://www.uttlab.com>
 UTTR-RF-FCCPART15.407-V1.3

No.	Frequency (MHz)	Reading (dBµV)	Correction factor (dB/m)	Result (dBµV/m)	Limit (dBµV/m)	Margin (dB)	Detector	Antenna Polaxis
IEEE 802.11ax-HE40_Channel 62								
1	10620.000	28.72	5.80	34.52	54	-19.48	Average	Horizontal
2	10620.000	42.45	5.80	48.25	74	-25.75	Peak	Horizontal
3	15930.000	21.82	11.04	32.86	54	-21.14	Average	Horizontal
4	15930.000	34.59	11.04	45.63	74	-28.37	Peak	Horizontal
5	10620.000	26.63	5.80	32.43	54	-21.57	Average	Vertical
6	10620.000	38.89	5.80	44.69	74	-29.31	Peak	Vertical
7	15930.000	21.82	11.04	32.86	54	-21.14	Average	Vertical
8	15930.000	34.09	11.04	45.13	74	-28.87	Peak	Vertical
IEEE 802.11ax-HE40_Channel 102								
1	11020.000	25.36	5.30	30.66	54	-23.34	Average	Horizontal
2	11020.000	37.56	5.30	42.86	74	-31.14	Peak	Horizontal
3	16530.000	21.77	12.21	33.98	54	-20.02	Average	Horizontal
4	16530.000	33.90	12.21	46.11	68.2	-22.09	Peak	Horizontal
5	11020.000	25.44	5.30	30.74	54	-23.26	Average	Vertical
6	11020.000	37.59	5.30	42.89	74	-31.11	Peak	Vertical
7	16530.000	21.77	12.21	33.98	54	-20.02	Average	Vertical
8	16530.000	34.46	12.21	46.67	68.2	-21.53	Peak	Vertical
IEEE 802.11ax-HE40_Channel 134								
1	11340.000	23.33	5.10	28.43	54	-25.57	Average	Horizontal
2	11340.000	34.40	5.10	39.50	74	-34.50	Peak	Horizontal
3	17010.000	20.76	13.02	33.78	54	-20.22	Average	Horizontal
4	17010.000	31.34	13.02	44.36	68.2	-23.84	Peak	Horizontal
5	11340.000	23.23	5.10	28.33	54	-25.67	Average	Vertical
6	11340.000	33.44	5.10	38.54	74	-35.46	Peak	Vertical
7	17010.000	20.89	13.02	33.91	54	-20.09	Average	Vertical
8	17010.000	31.57	13.02	44.59	68.2	-23.61	Peak	Vertical
IEEE 802.11ax-HE40_Channel 142								
1	11420.000	24.37	5.04	29.41	54	-24.59	Average	Horizontal
2	11420.000	35.89	5.04	40.93	74	-33.07	Peak	Horizontal
3	17130.000	20.40	13.45	33.85	54	-20.15	Average	Horizontal
4	17130.000	31.77	13.45	45.22	68.2	-22.98	Peak	Horizontal
5	11420.000	24.63	5.04	29.67	54	-24.33	Average	Vertical
6	11420.000	36.30	5.04	41.34	74	-32.66	Peak	Vertical
7	17130.000	20.67	13.45	34.12	54	-19.88	Average	Vertical
8	17130.000	32.13	13.45	45.58	68.2	-22.62	Peak	Vertical

Shenzhen UnionTrust Quality and Technology Co., Ltd.

Address: Unit D/E of 9/F and 16/F, Block A, Building 6, Baoneng science and technology park, Longhua district, Shenzhen, China
 Tel: +86-755-28230888 Fax: +86-755-28230886 E-mail: info@uttlab.com <http://www.uttlab.com>
 UTTR-RF-FCCPART15.407-V1.3

No.	Frequency (MHz)	Reading (dBµV)	Correction factor (dB/m)	Result (dBµV/m)	Limit (dBµV/m)	Margin (dB)	Detector	Antenna Polaxis
IEEE 802.11ax-HE40_Channel 151								
1	11510.000	23.61	4.98	28.59	54	-25.41	Average	Horizontal
2	11510.000	34.53	4.98	39.51	74	-34.49	Peak	Horizontal
3	17265.000	21.03	13.94	34.97	54	-19.03	Average	Horizontal
4	17265.000	33.07	13.94	47.01	68.2	-21.19	Peak	Horizontal
5	11510.000	23.80	4.98	28.78	54	-25.22	Average	Vertical
6	11510.000	35.63	4.98	40.61	74	-33.39	Peak	Vertical
7	17265.000	21.41	13.94	35.35	54	-18.65	Average	Vertical
8	17265.000	32.77	13.94	46.71	68.2	-21.49	Peak	Vertical
IEEE 802.11ax-HE40_Channel 159								
1	11590.000	23.71	4.94	28.65	54	-25.35	Average	Horizontal
2	11590.000	34.18	4.94	39.12	74	-34.88	Peak	Horizontal
3	17385.000	21.59	14.37	35.96	54	-18.04	Average	Horizontal
4	17385.000	31.97	14.37	46.34	68.2	-21.86	Peak	Horizontal
5	11590.000	23.99	4.94	28.93	54	-25.07	Average	Vertical
6	11590.000	34.59	4.94	39.53	74	-34.47	Peak	Vertical
7	17385.000	21.94	14.37	36.31	54	-17.69	Average	Vertical
8	17385.000	32.61	14.37	46.98	68.2	-21.22	Peak	Vertical

Remark:

1. Correct Factor = Antenna Factor + Cable Loss - Amplifier Gain, the value was added to Original Receiver Reading by the software automatically.
2. Result = Reading + Correct Factor.
3. Margin = Result – Limit

Band Edge Measurements (Radiated)

IEEE 802.11a

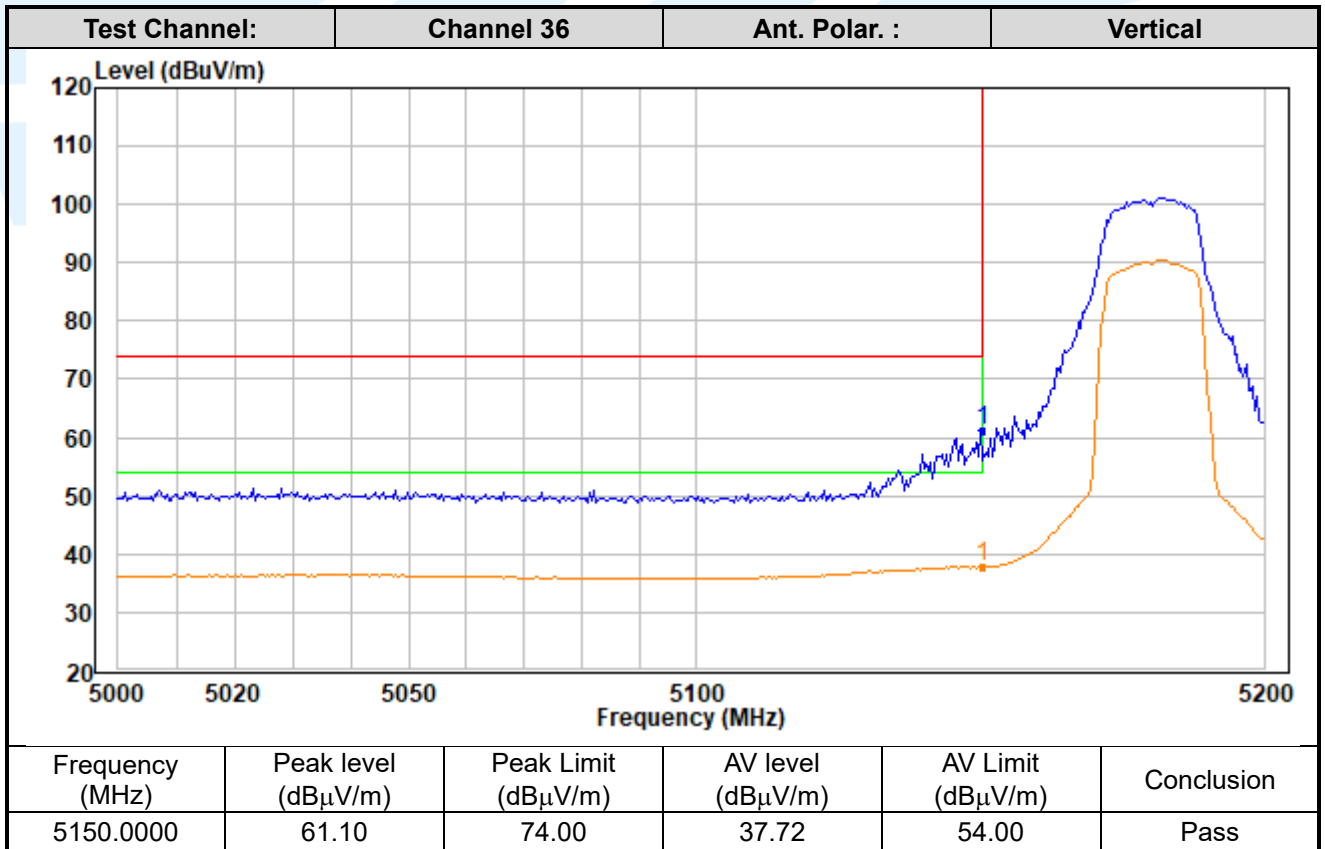
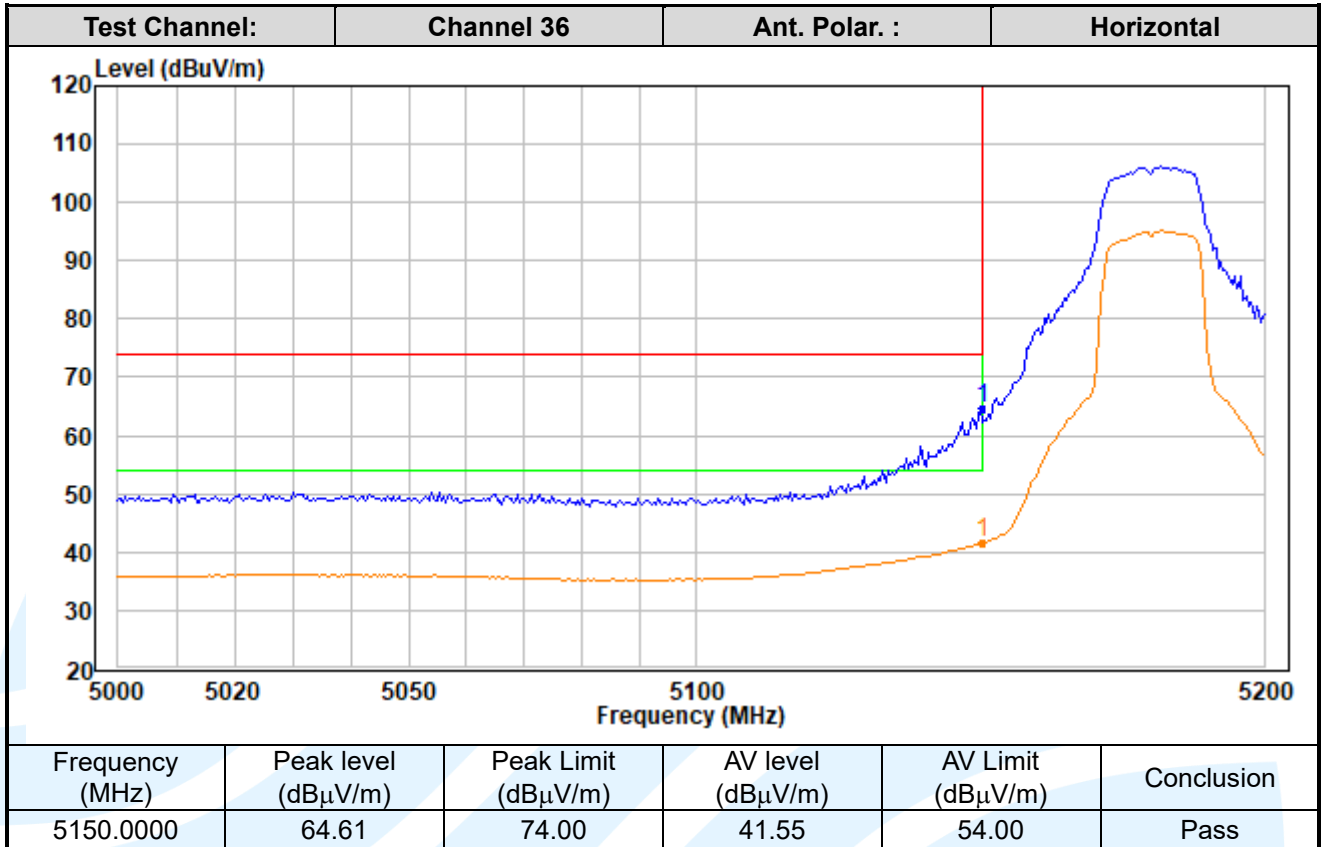

Shenzhen UnionTrust Quality and Technology Co., Ltd.

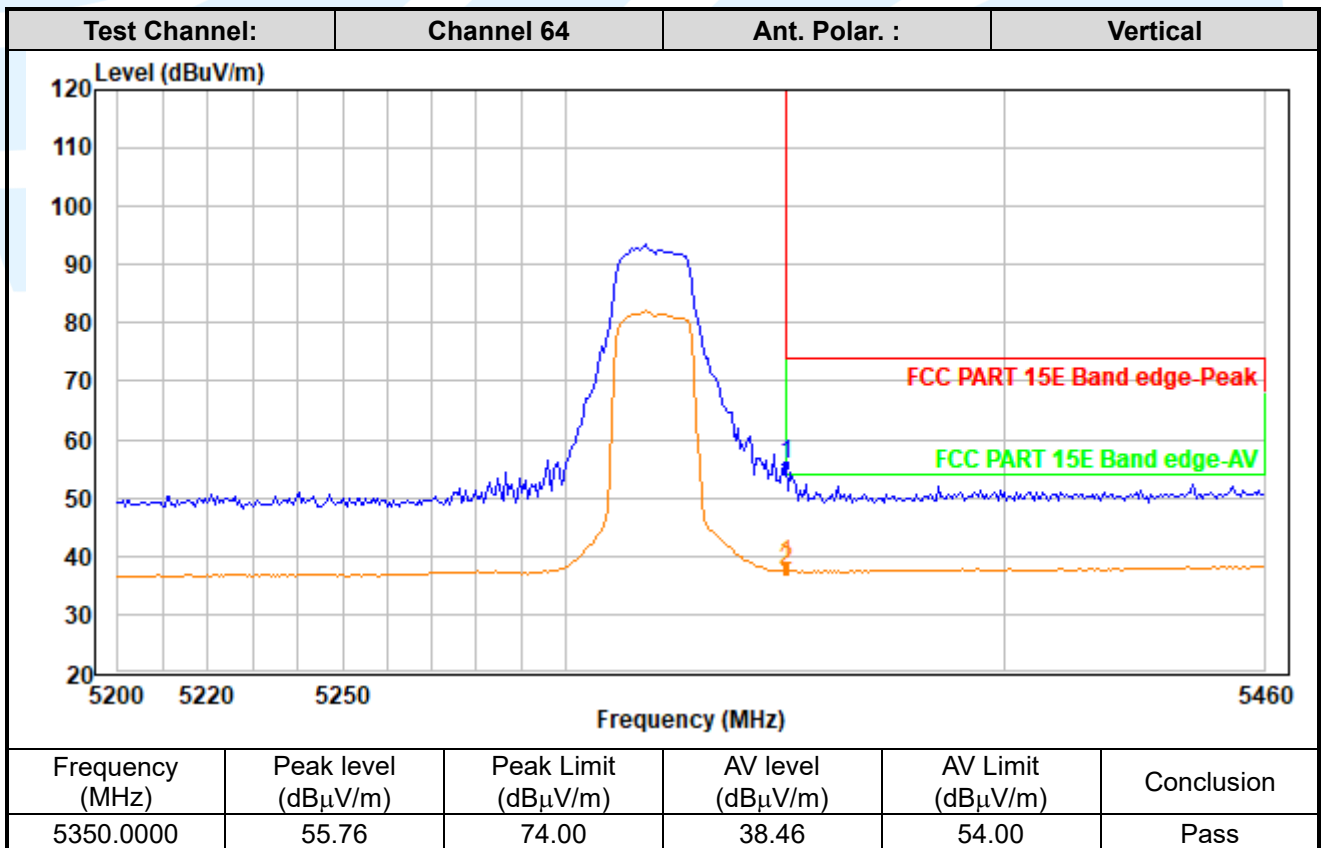
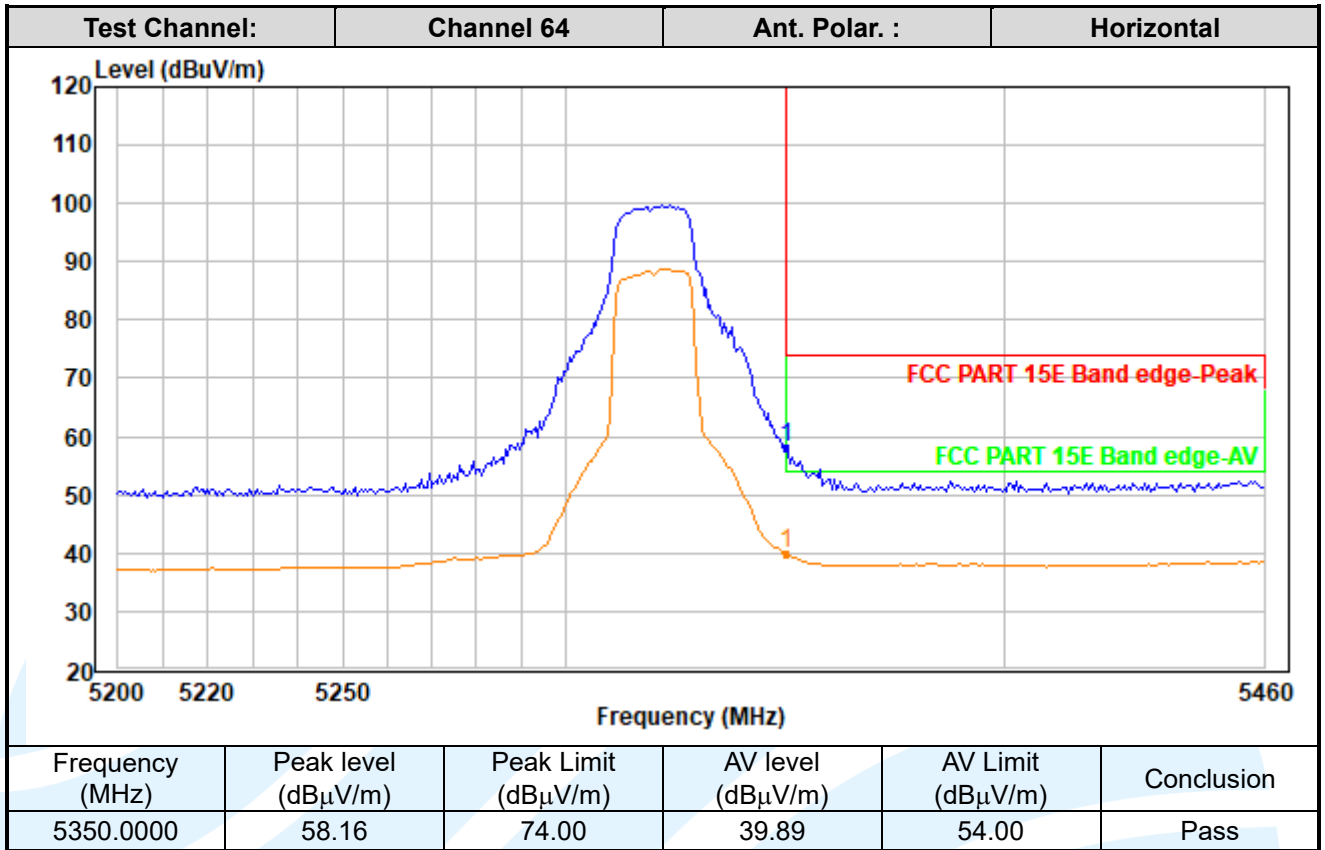

Shenzhen UnionTrust Quality and Technology Co., Ltd.

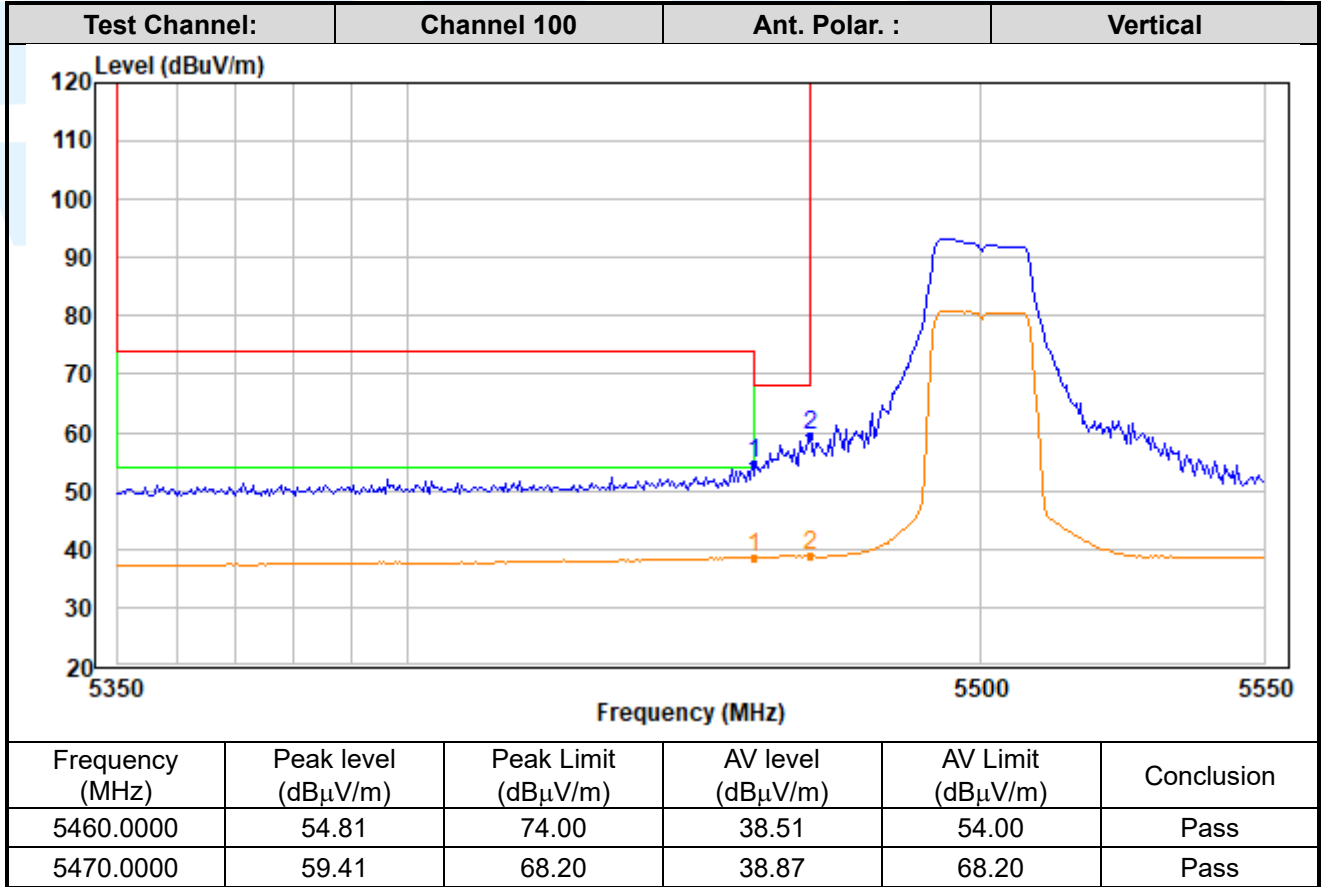
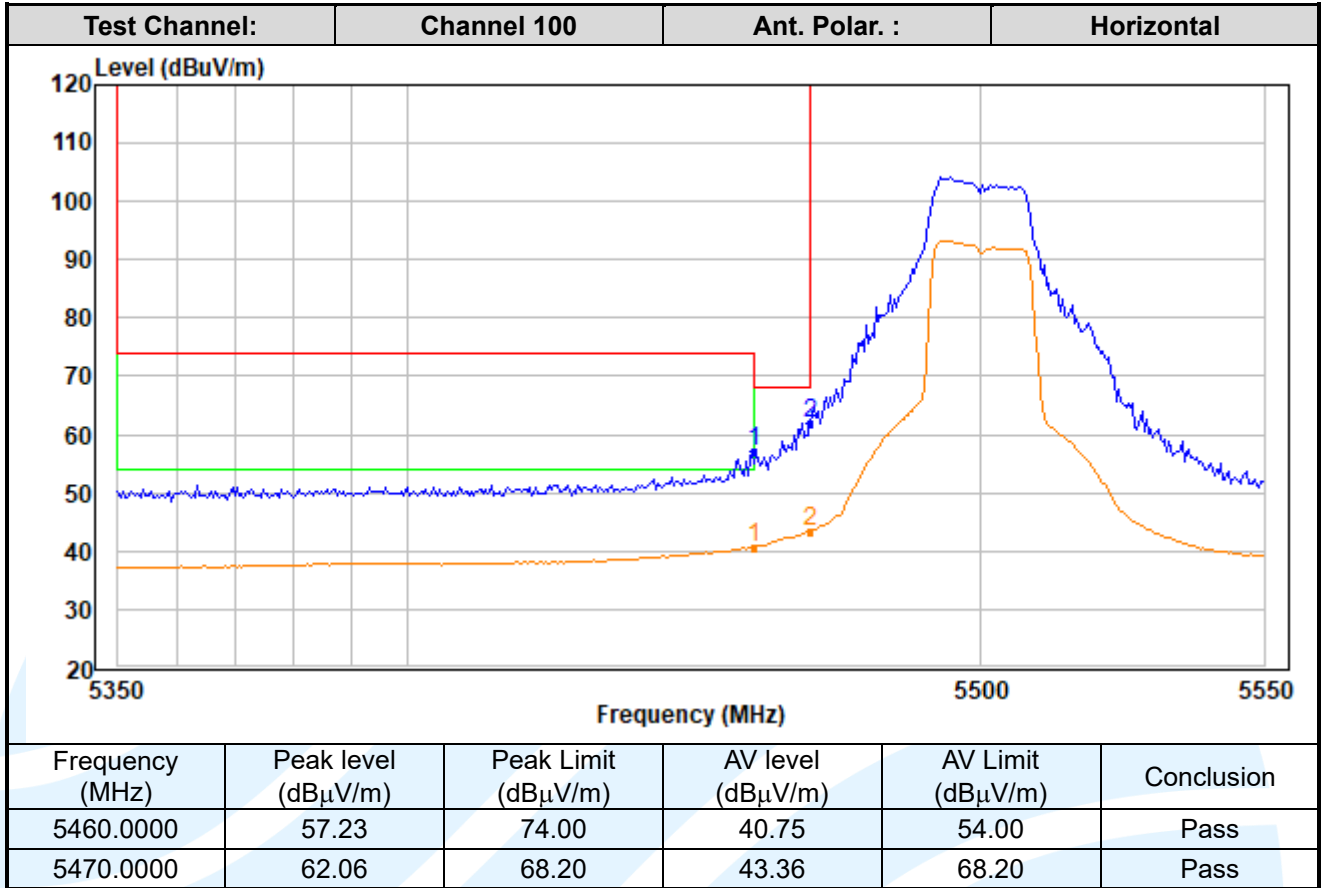

Shenzhen UnionTrust Quality and Technology Co., Ltd.

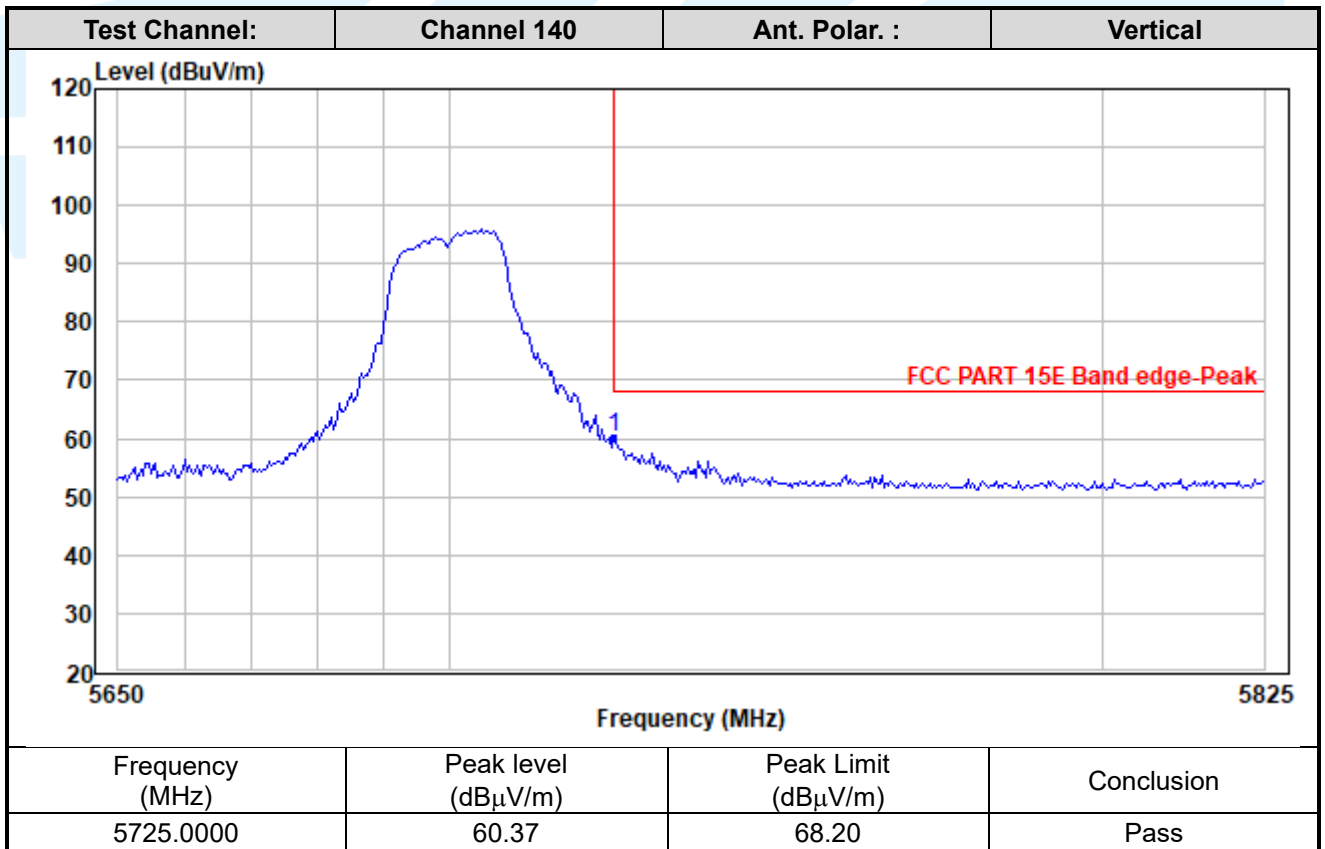
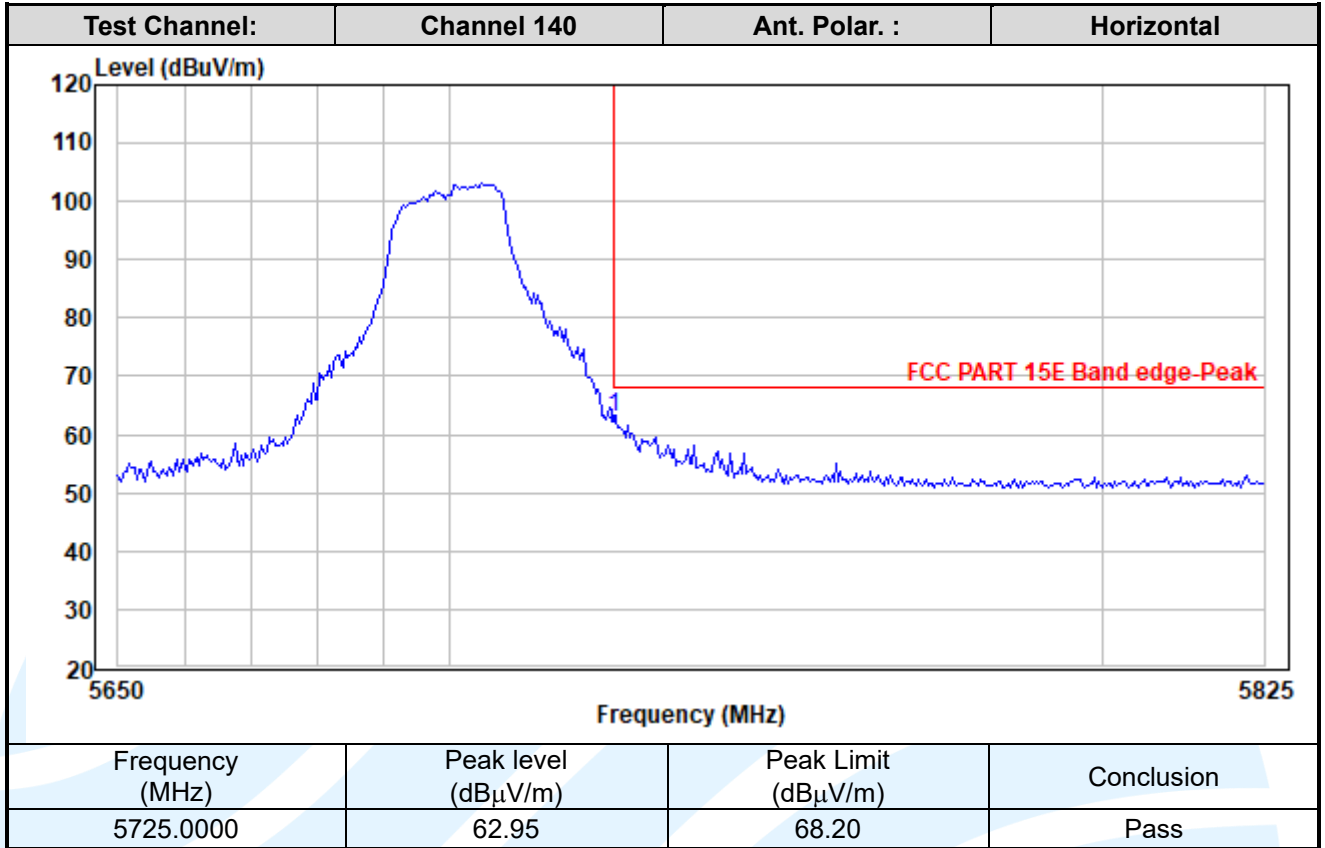

Shenzhen UnionTrust Quality and Technology Co., Ltd.

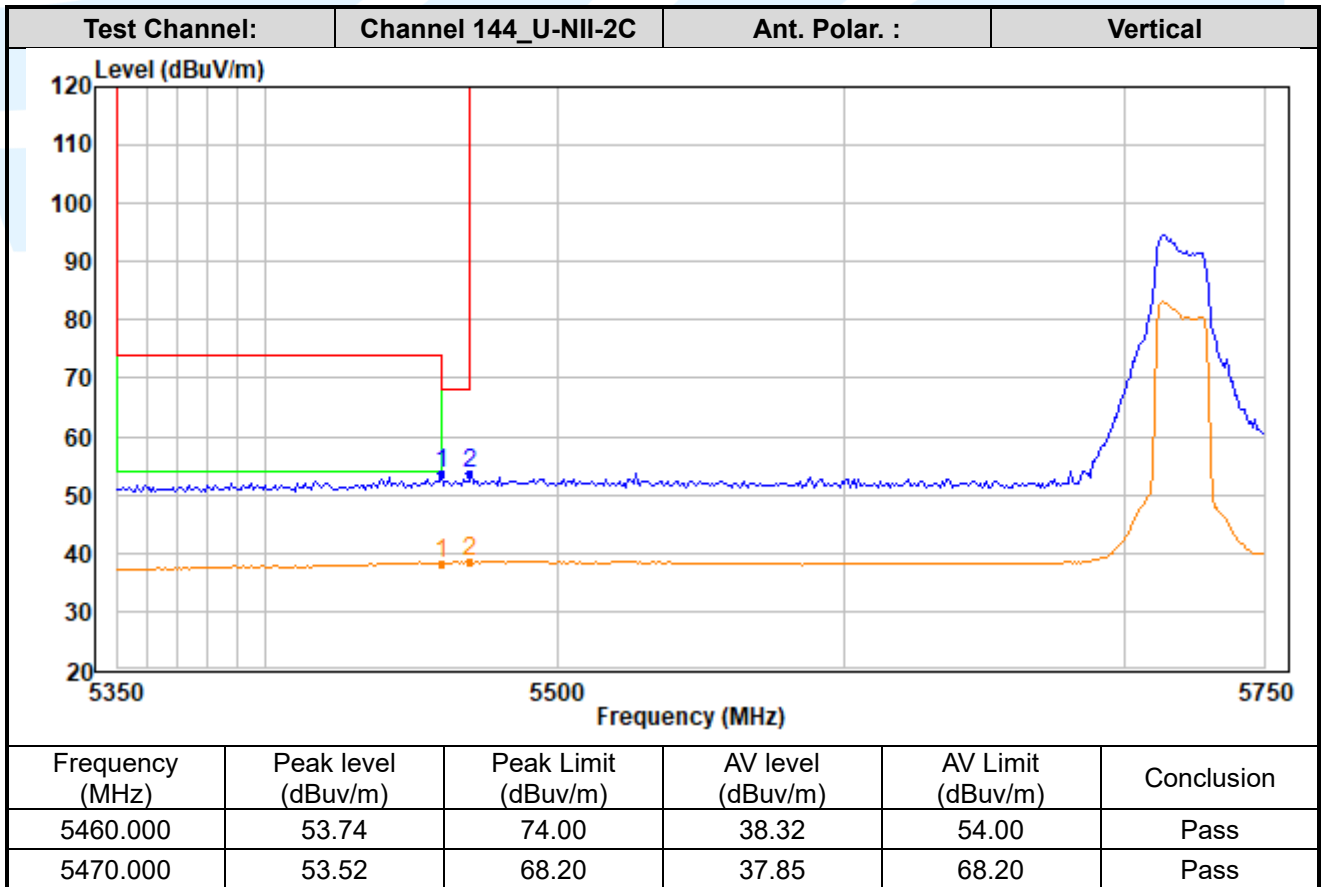
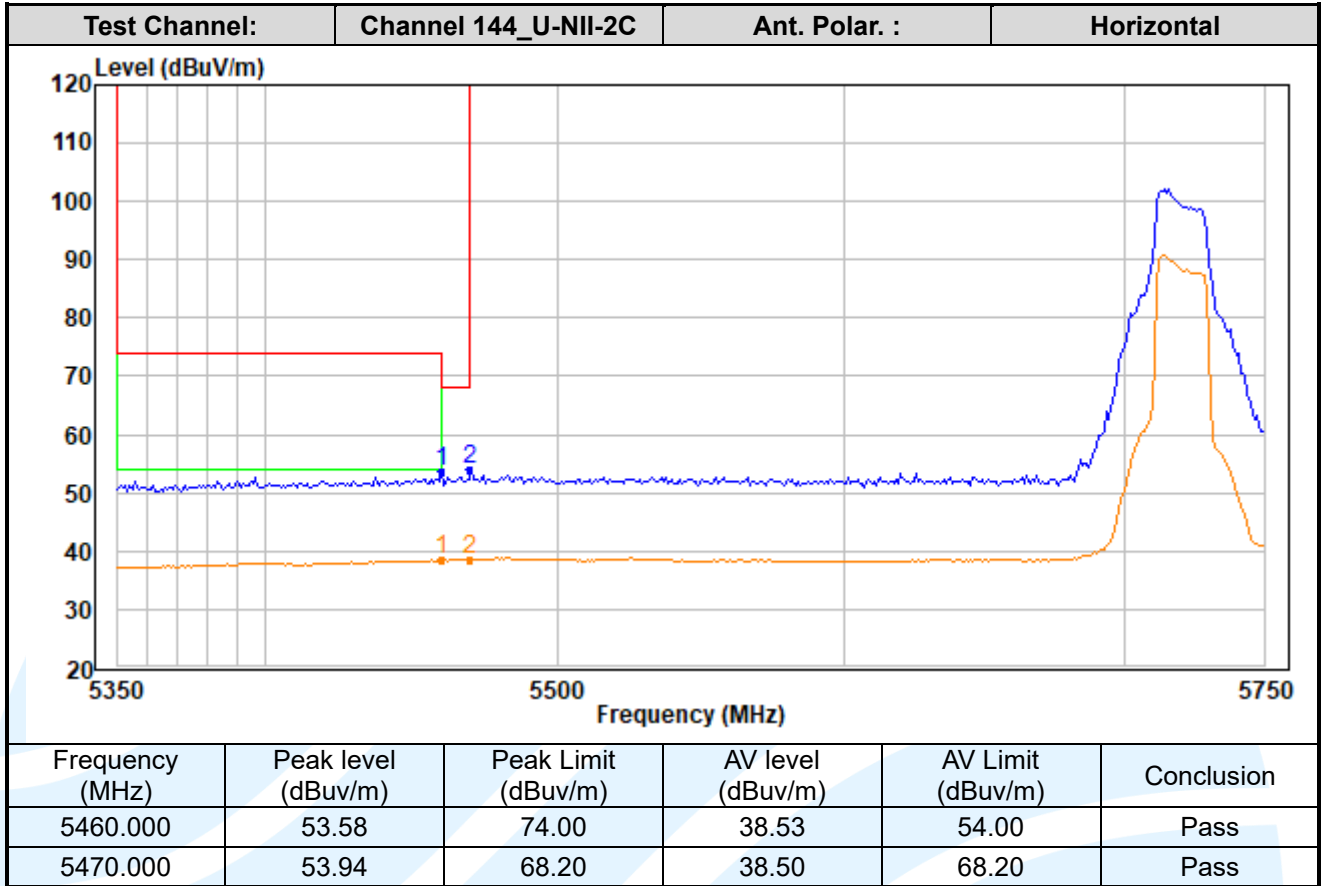

Shenzhen UnionTrust Quality and Technology Co., Ltd.

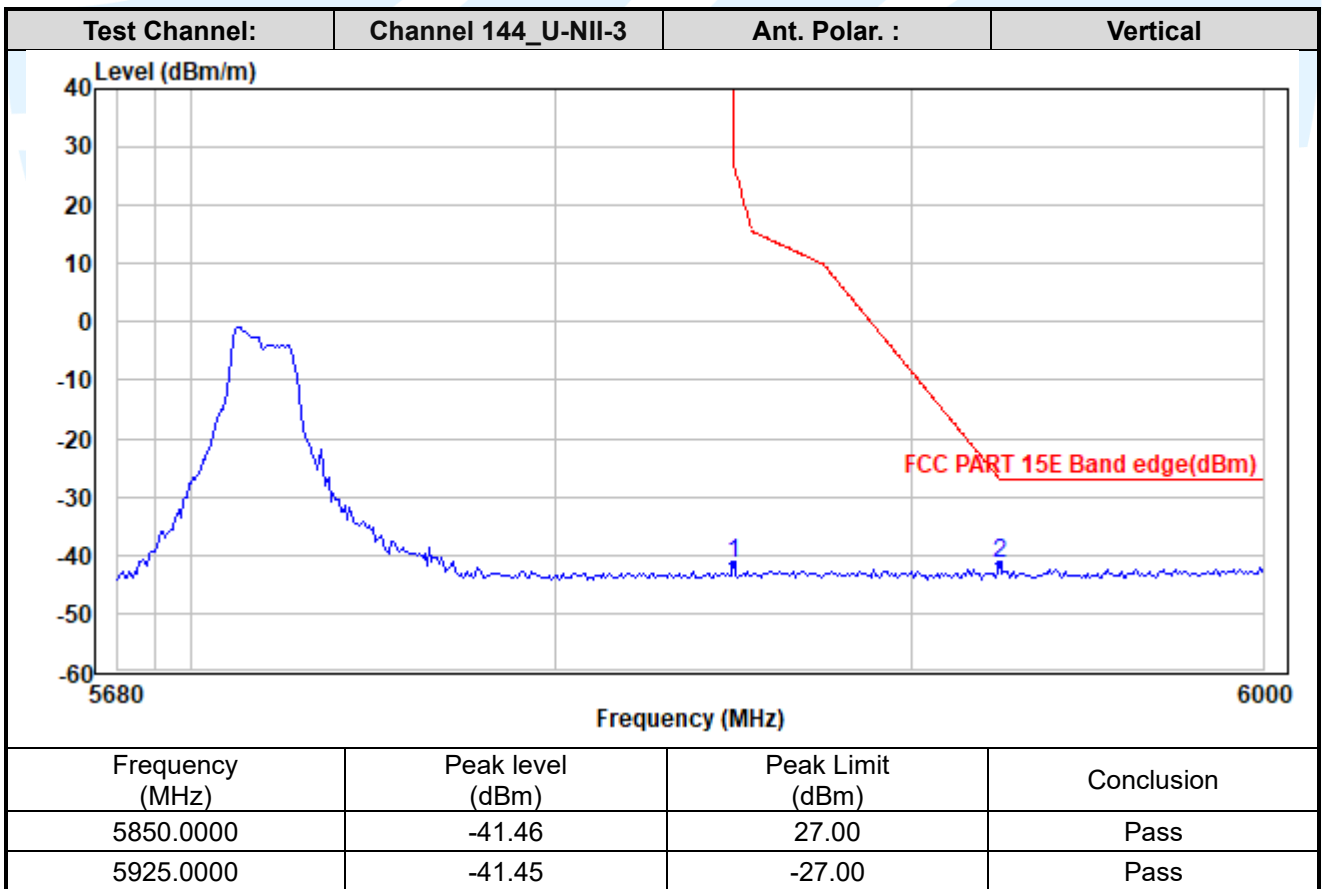
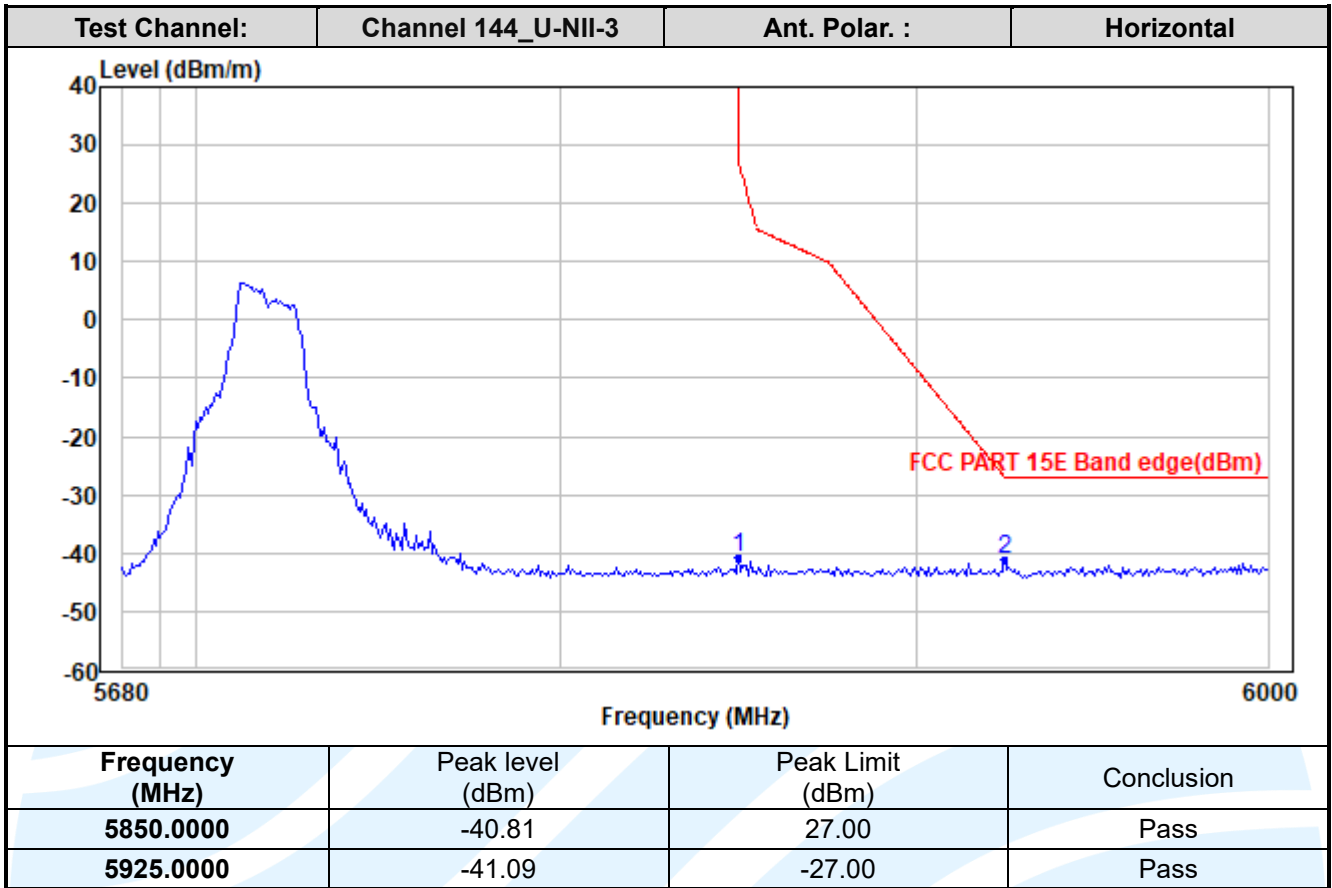

Shenzhen UnionTrust Quality and Technology Co., Ltd.

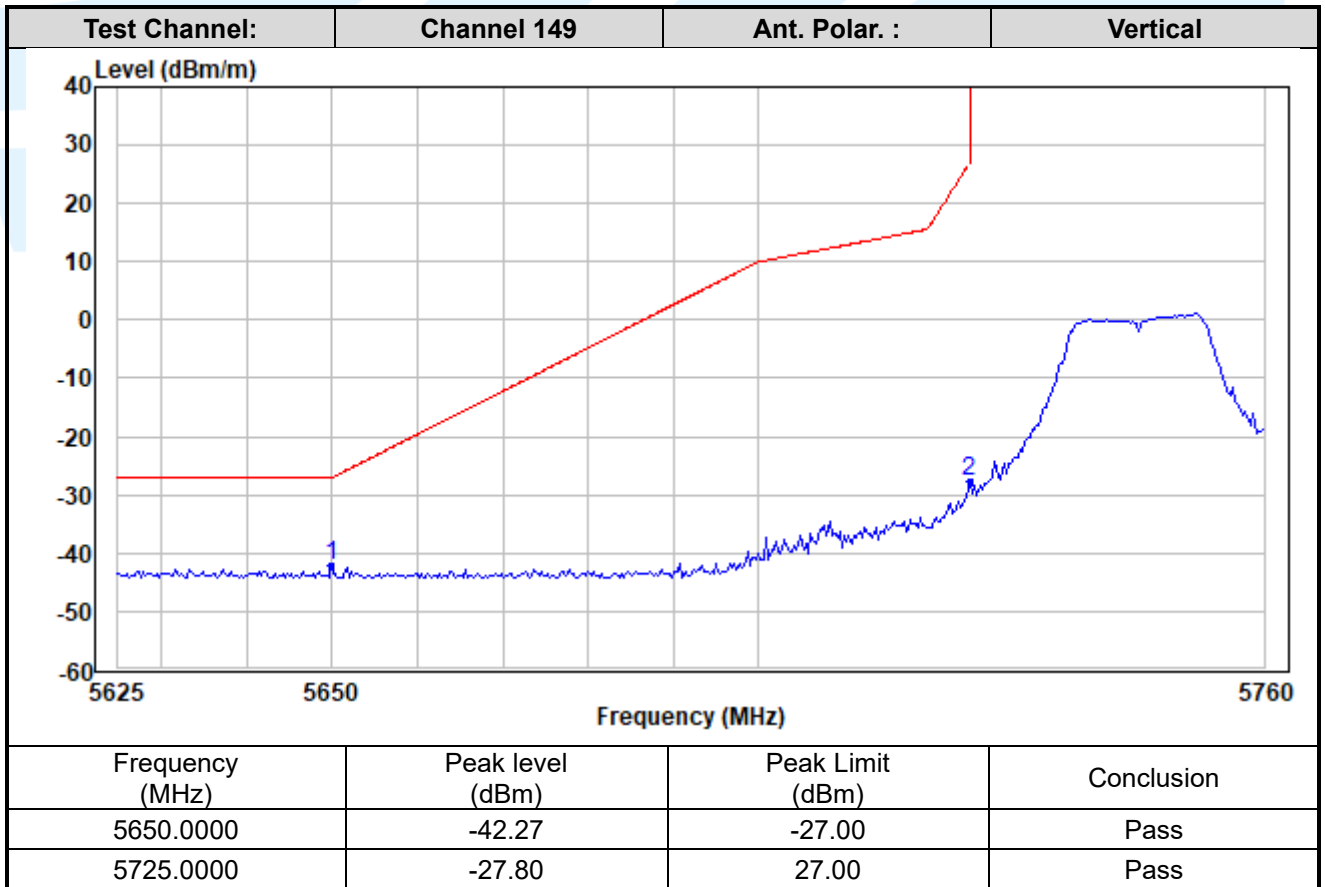
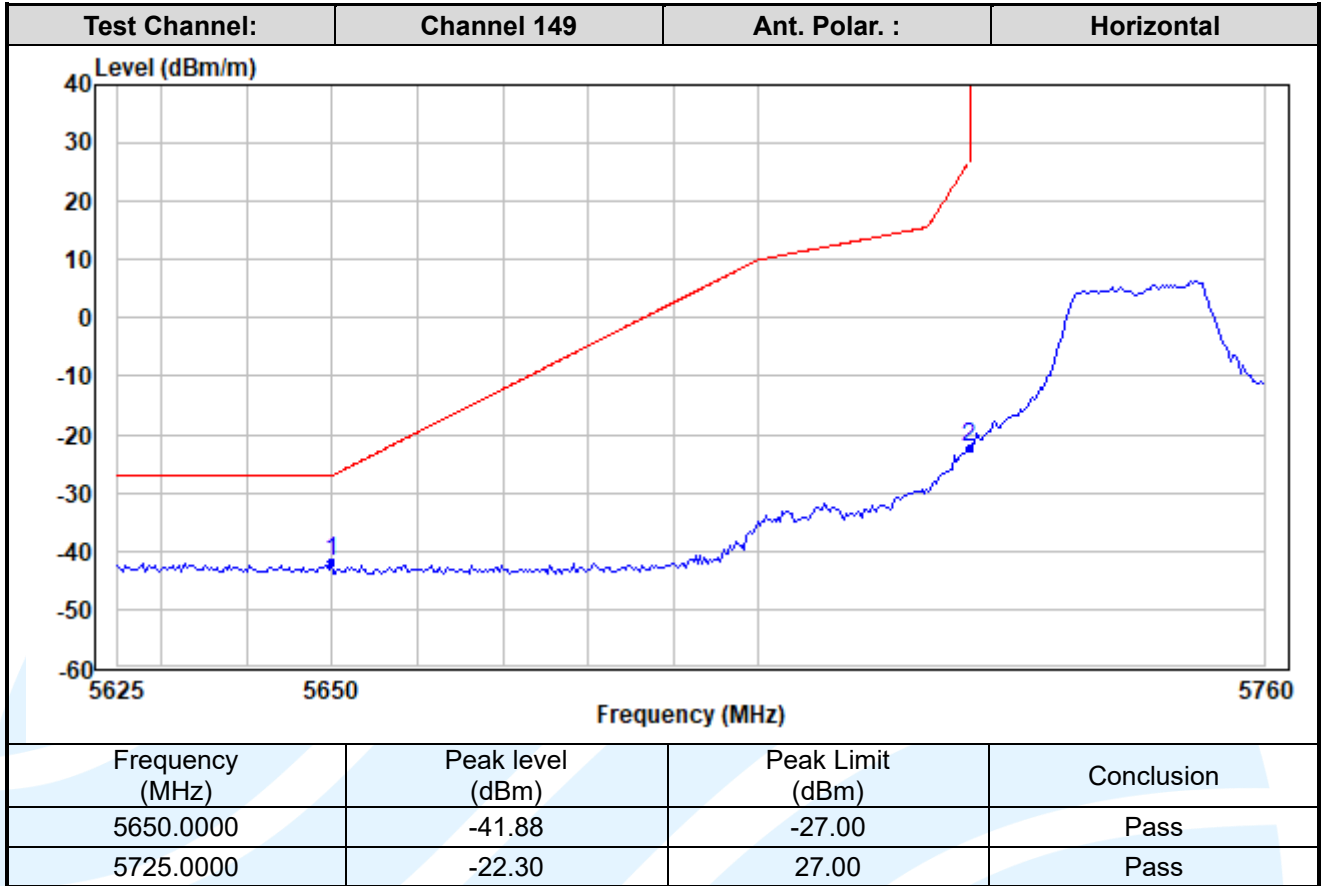

Shenzhen UnionTrust Quality and Technology Co., Ltd.

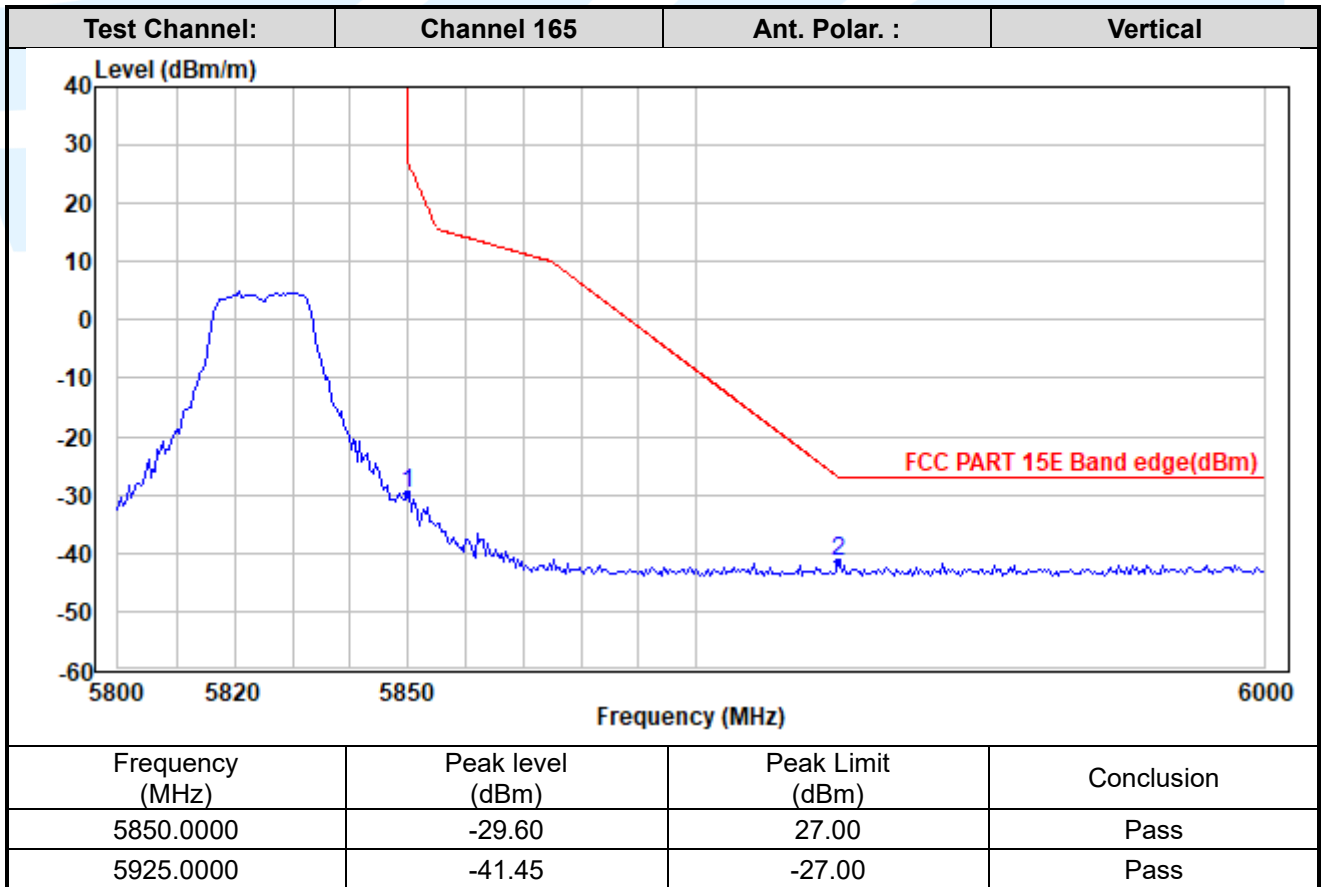
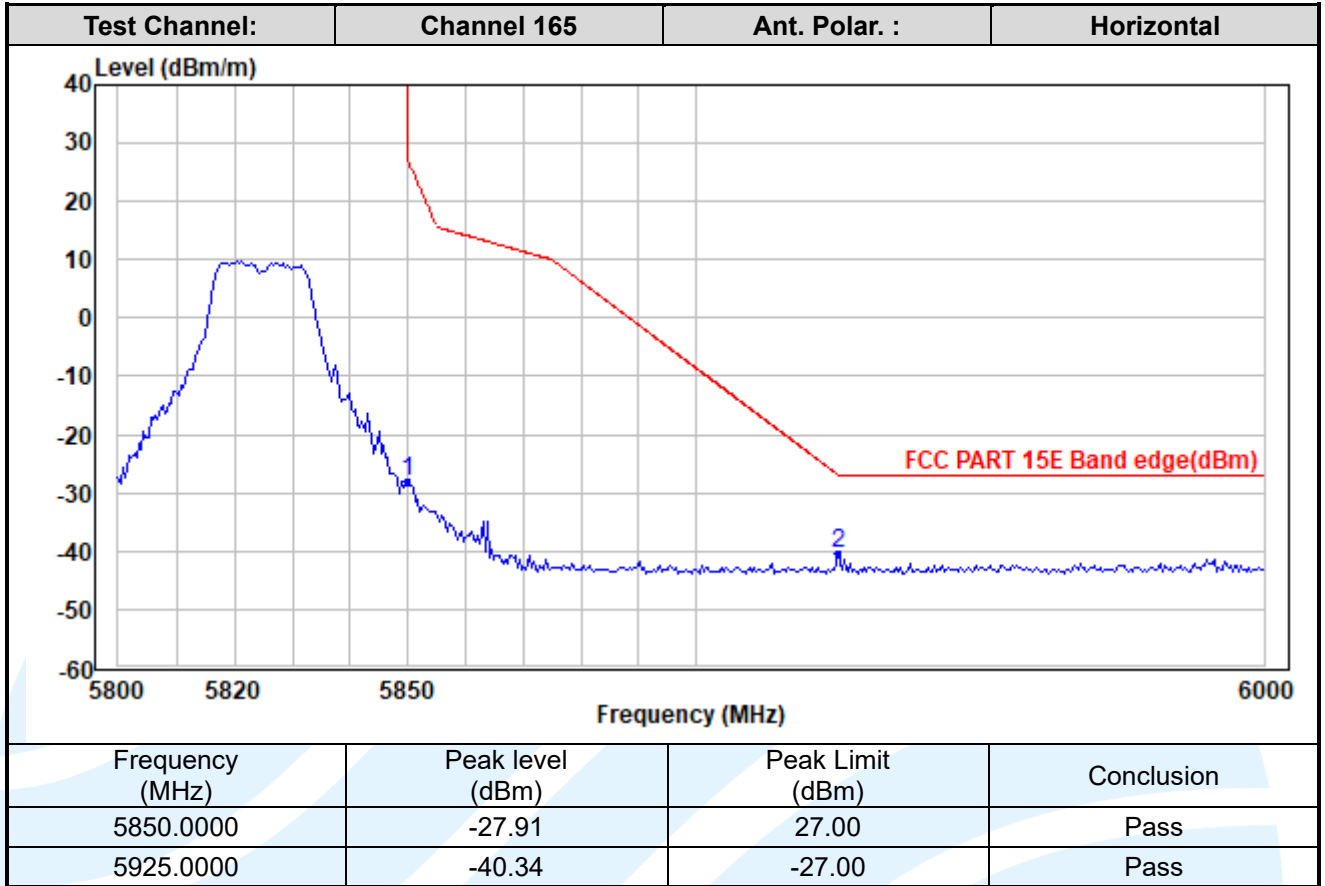

Shenzhen UnionTrust Quality and Technology Co., Ltd.

IEEE 802.11n-HT20

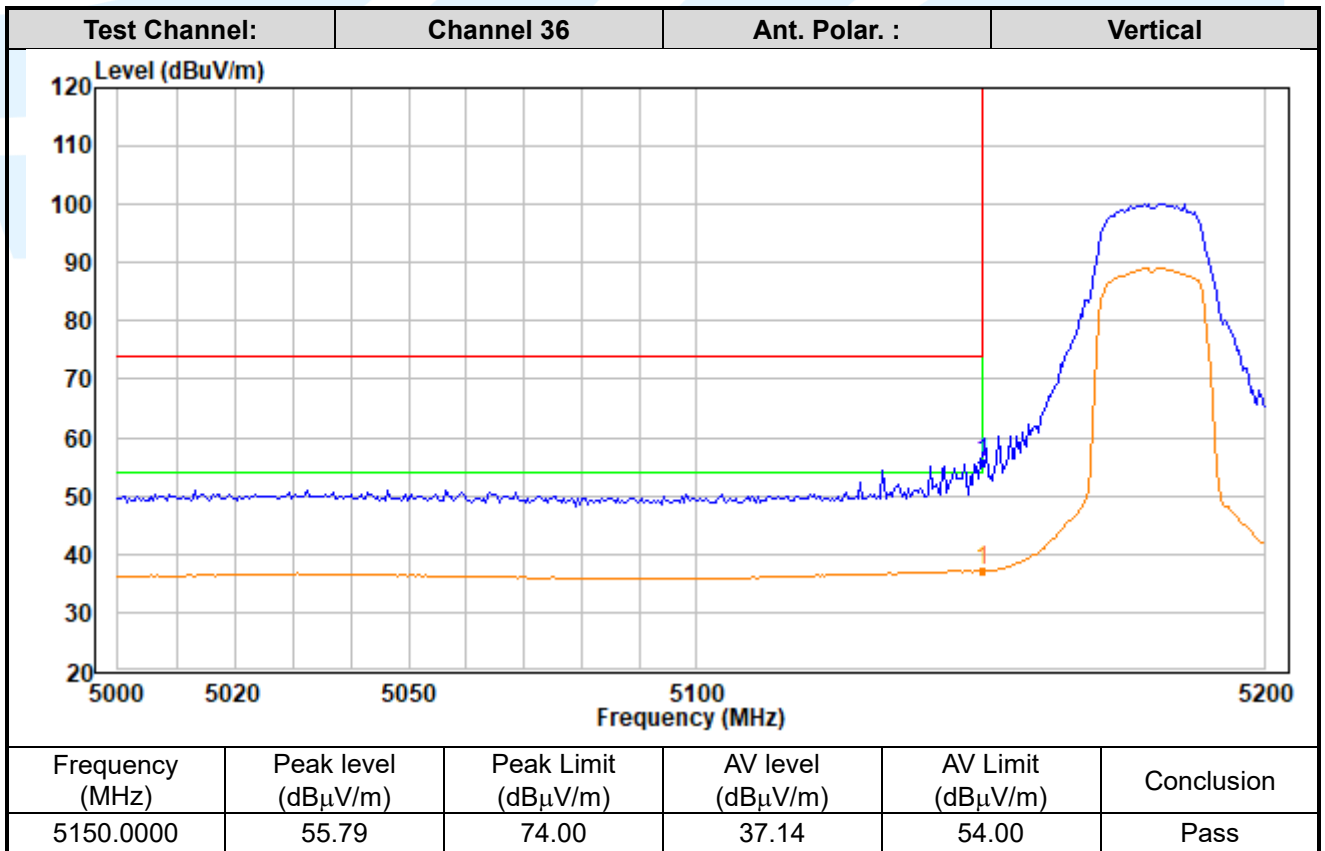
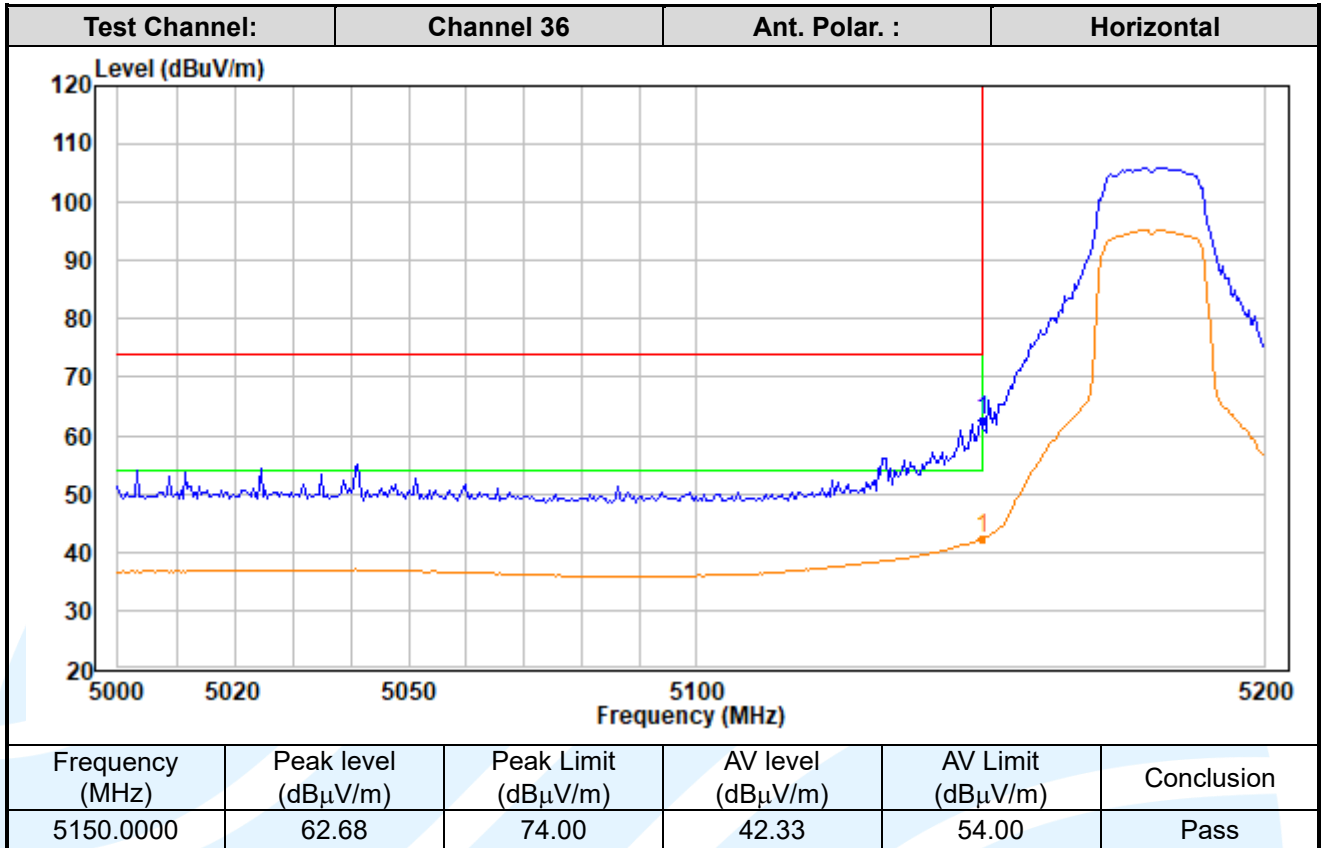

Shenzhen UnionTrust Quality and Technology Co., Ltd.

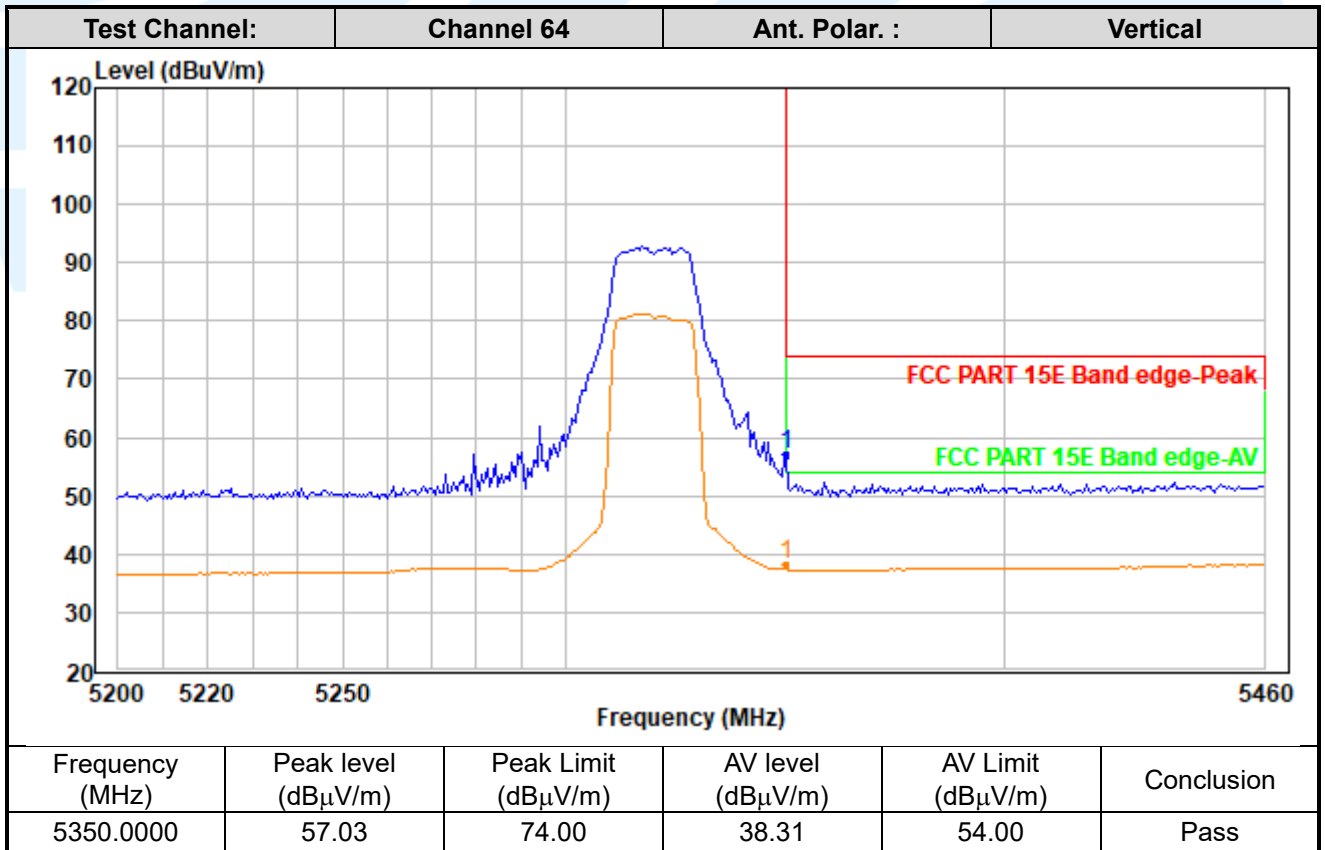
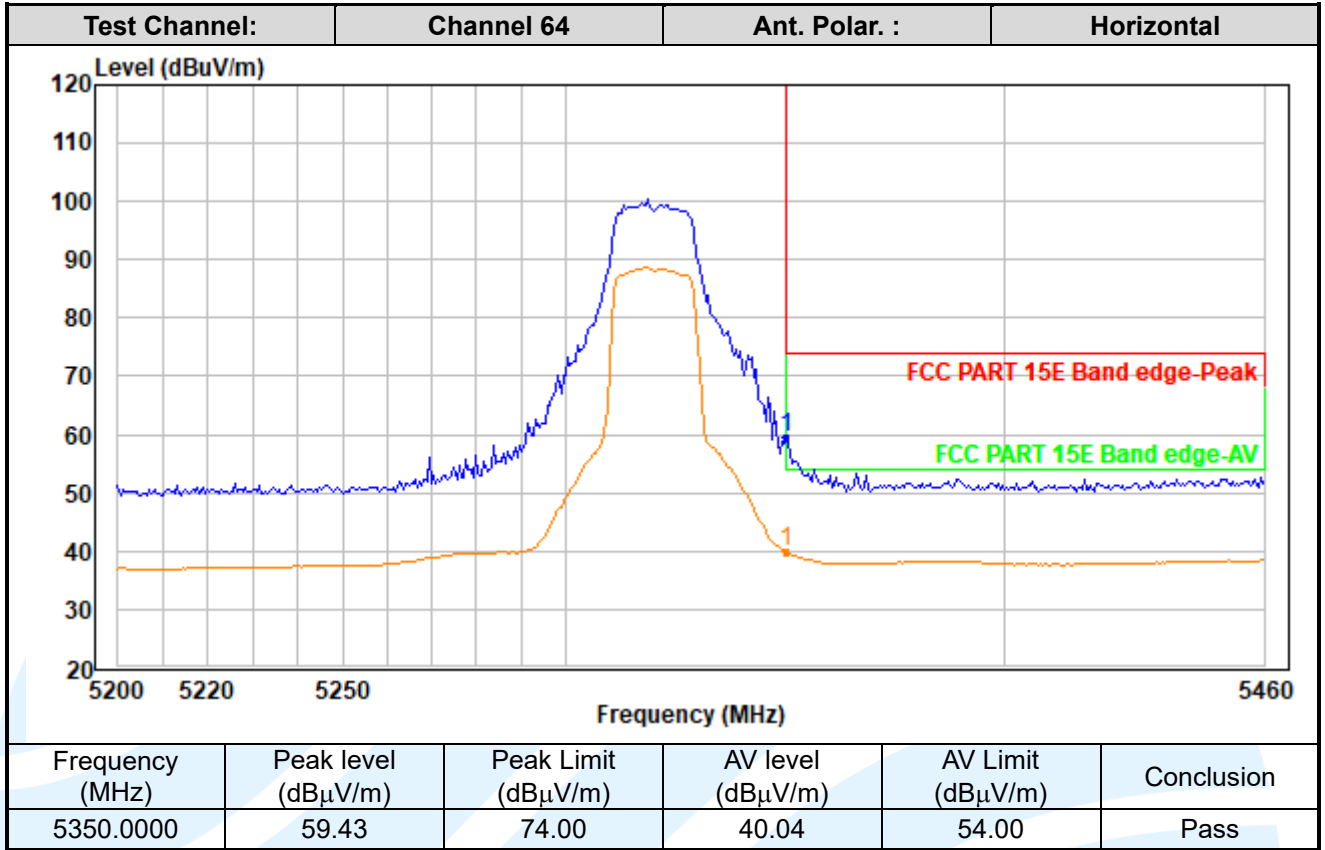

Shenzhen UnionTrust Quality and Technology Co., Ltd.

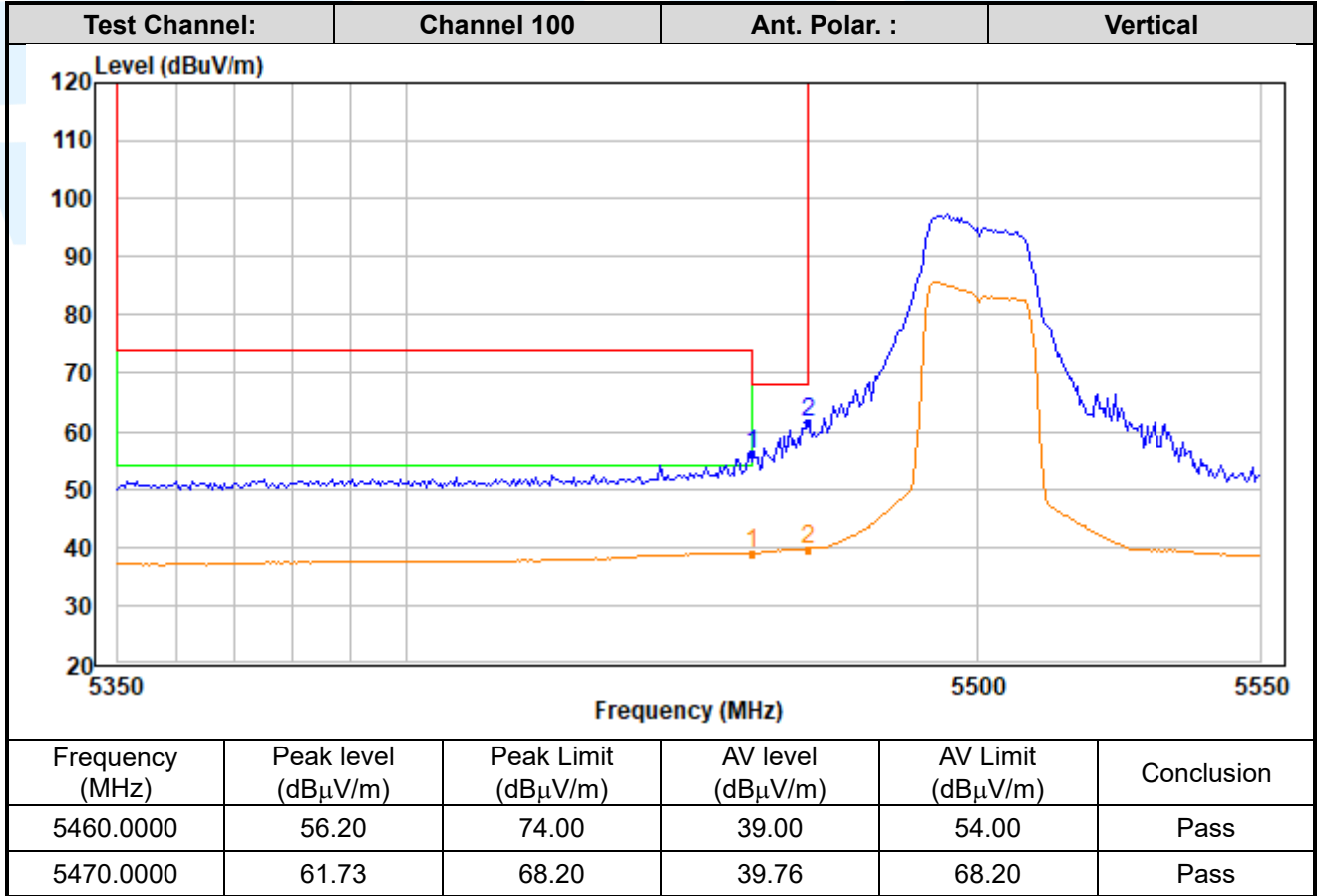
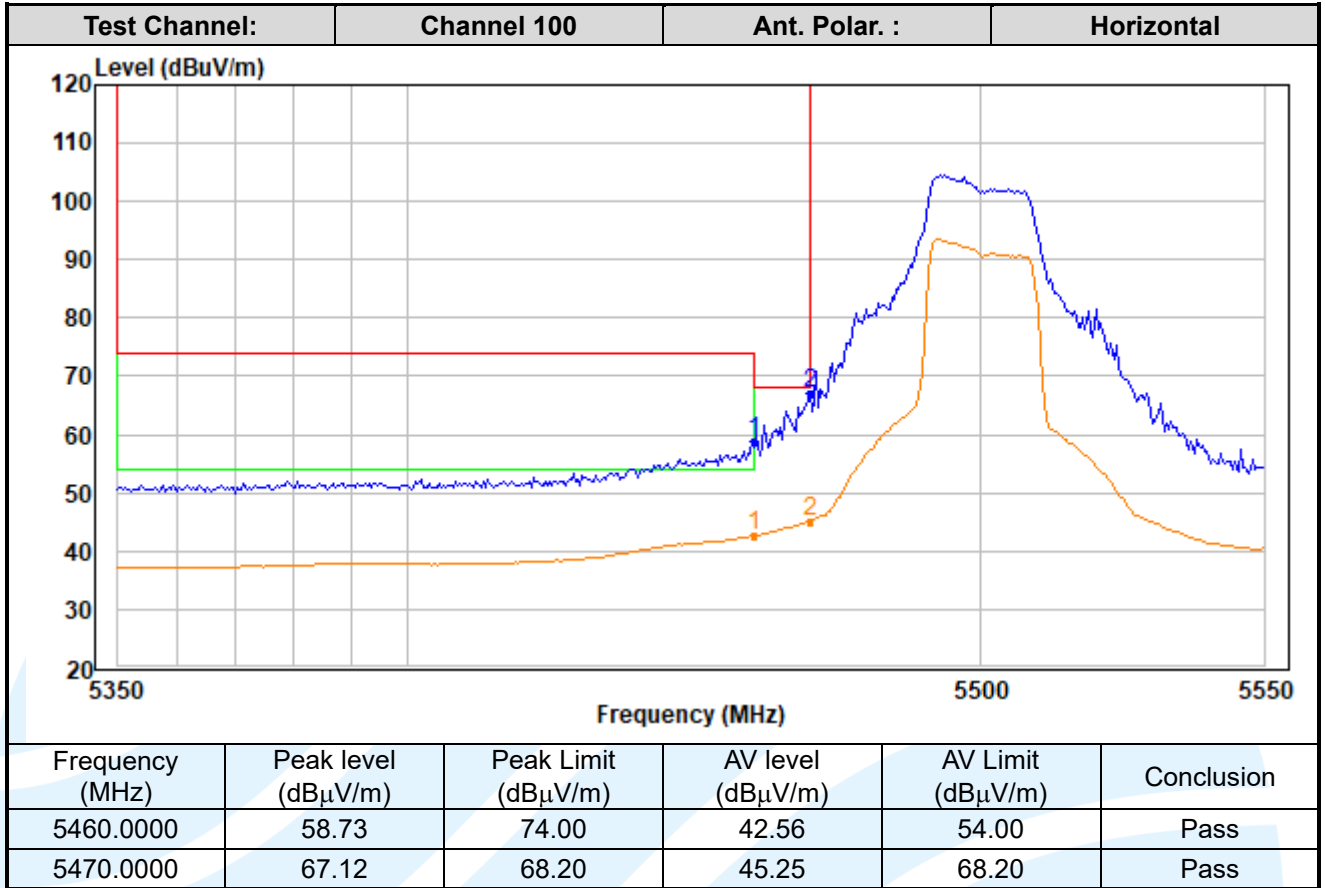

Shenzhen UnionTrust Quality and Technology Co., Ltd.

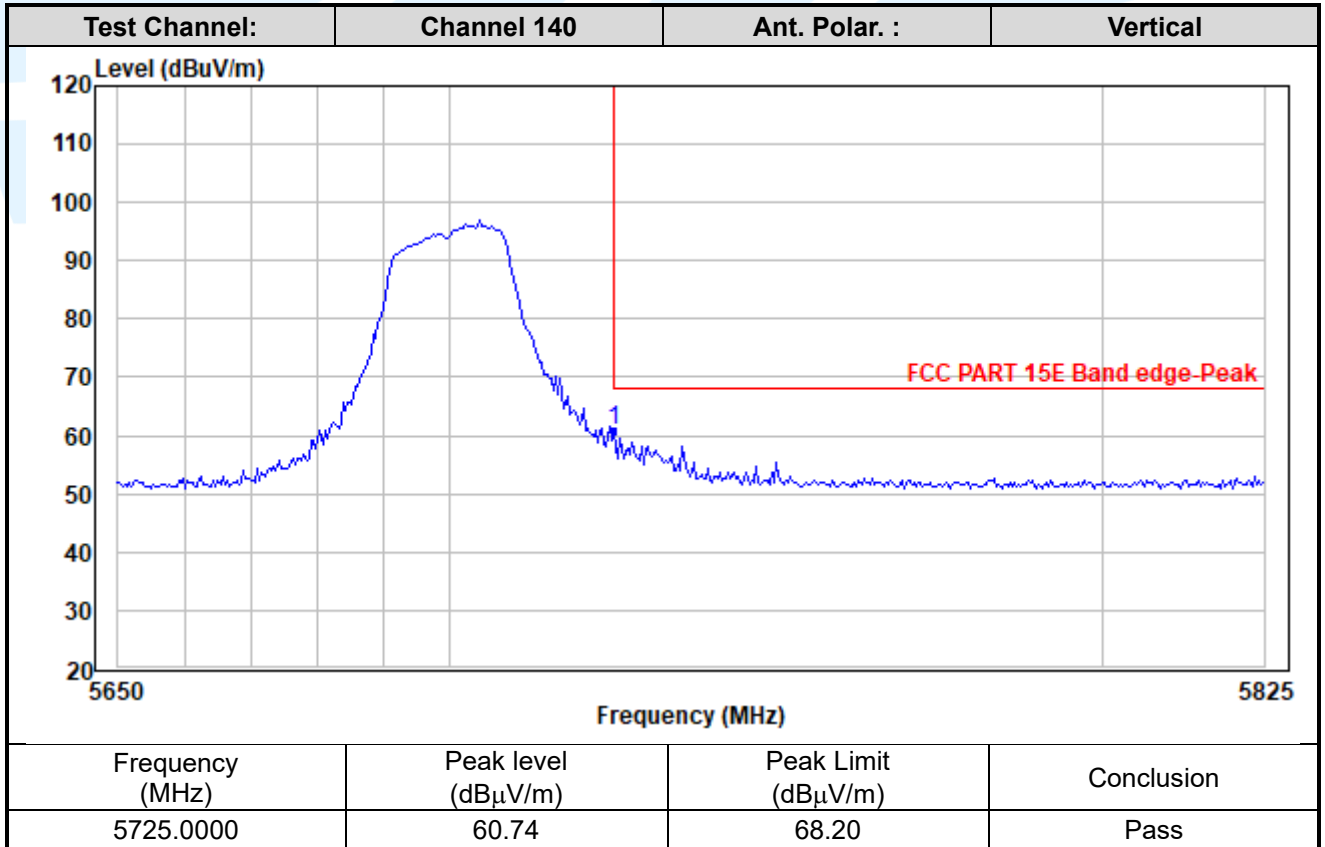
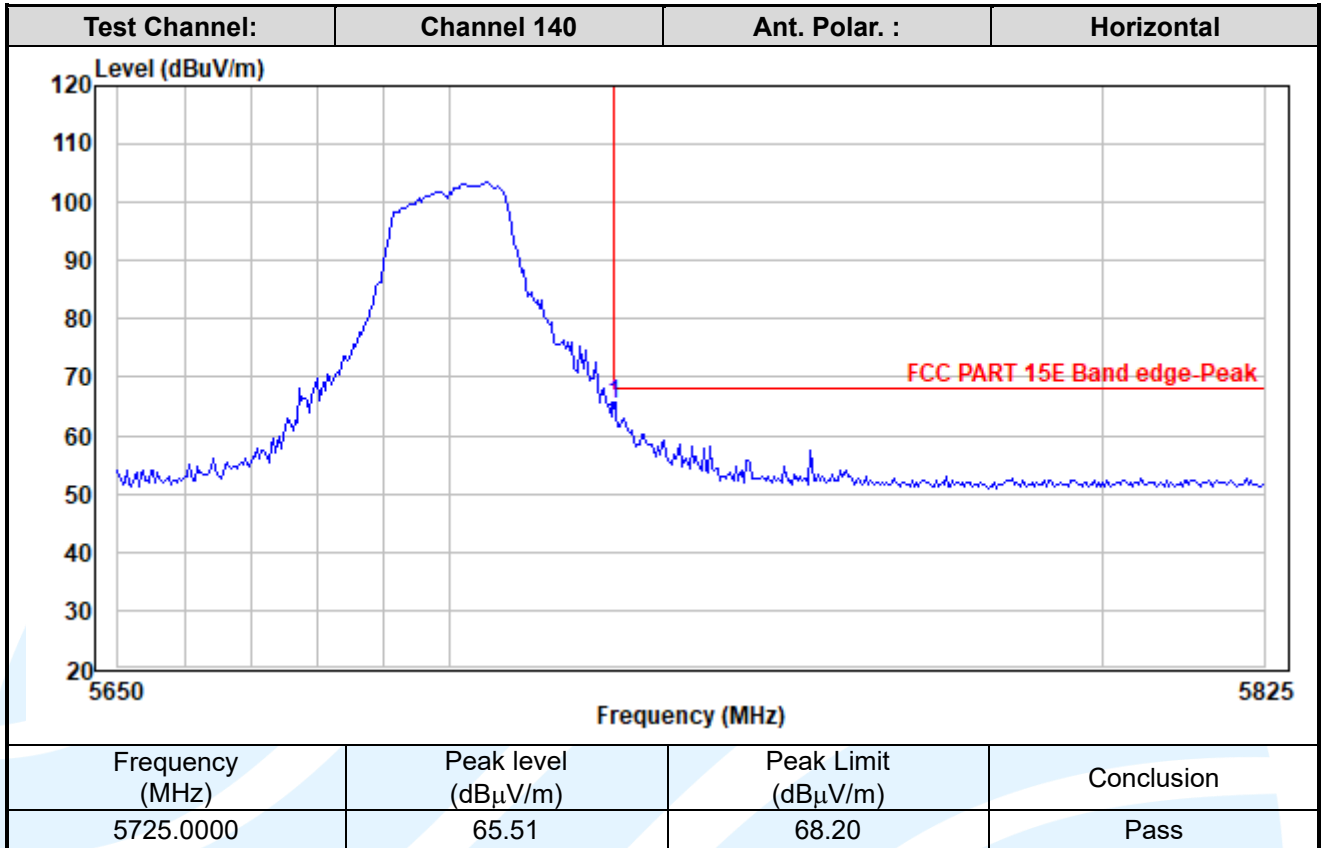

Shenzhen UnionTrust Quality and Technology Co., Ltd.

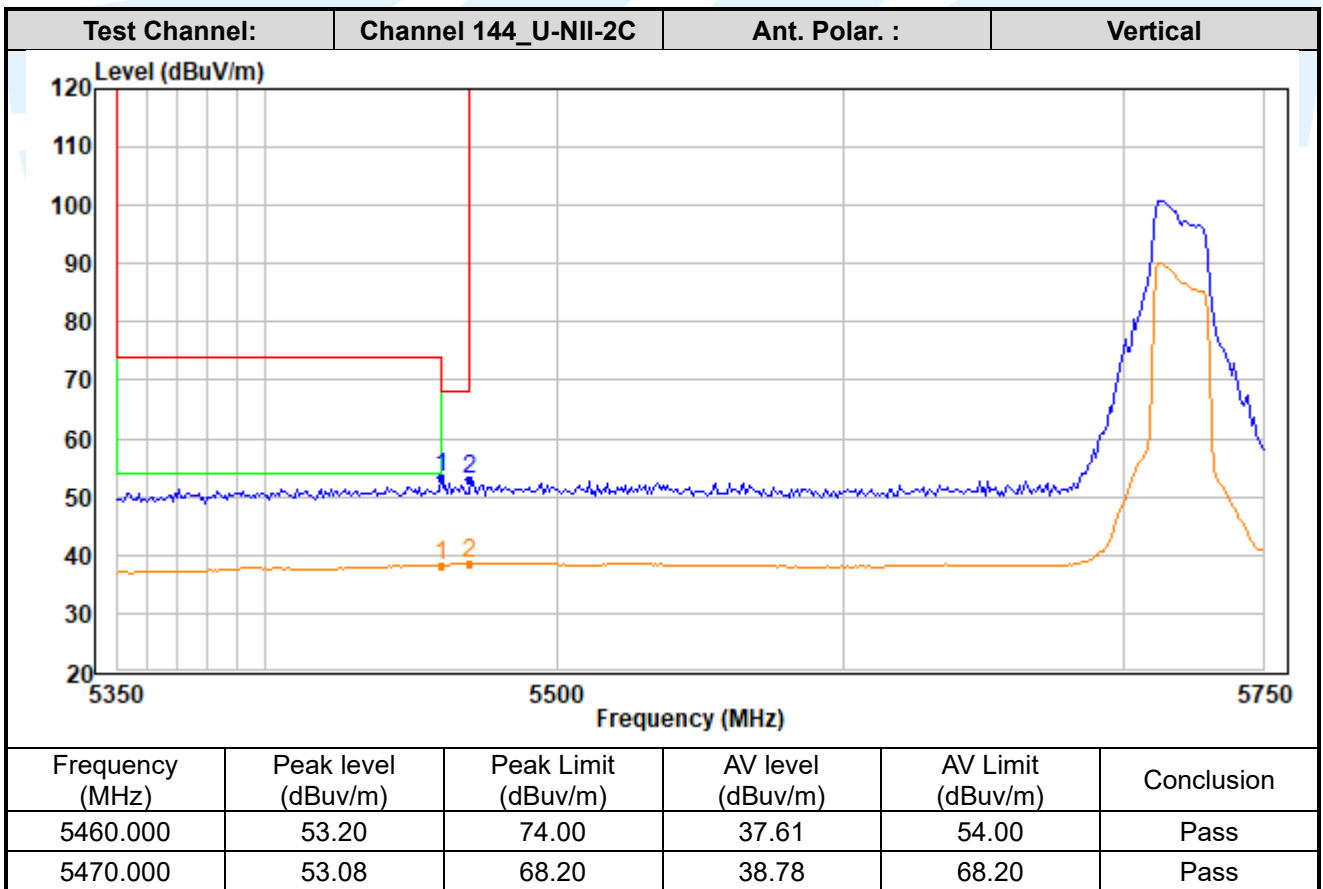
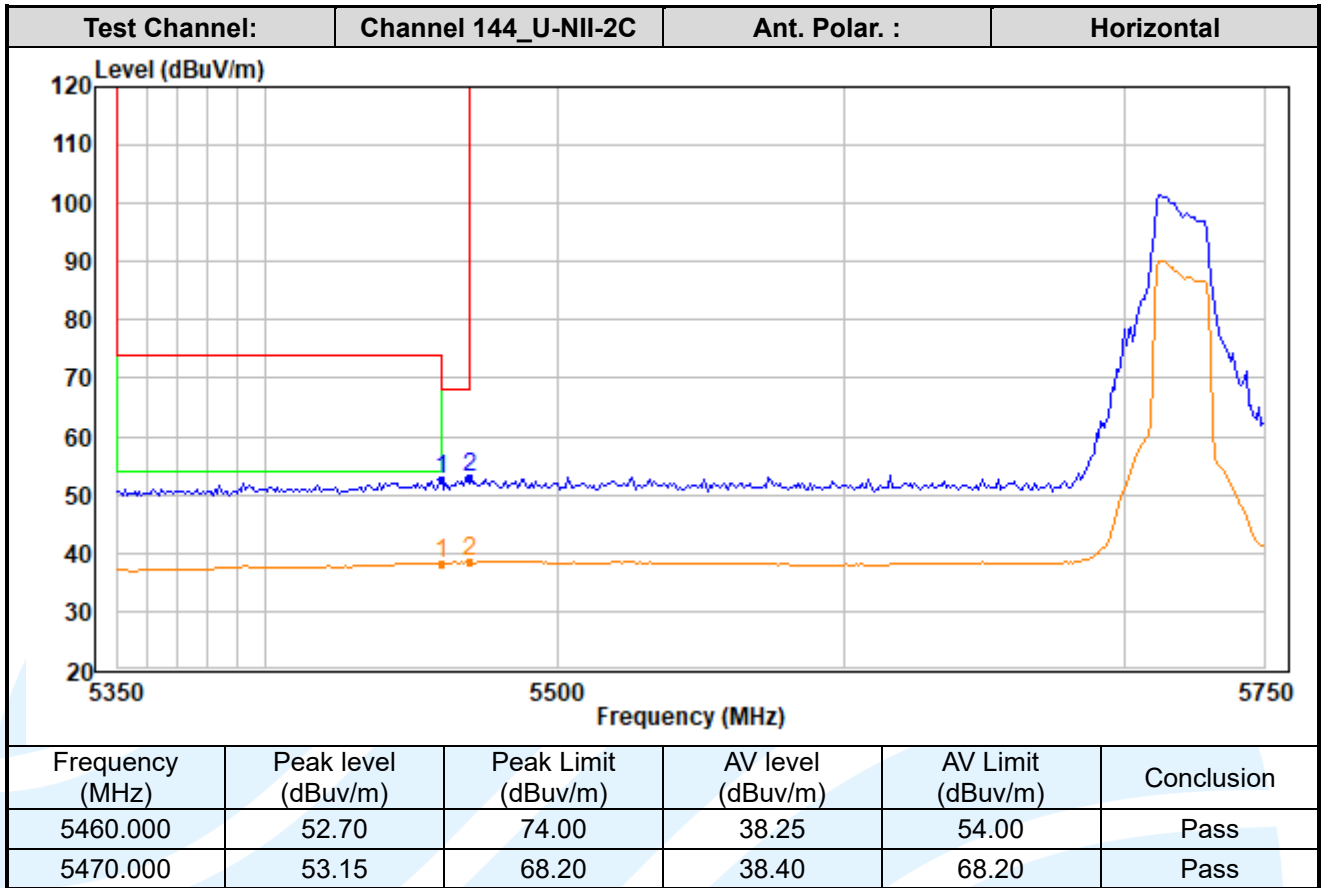

Shenzhen UnionTrust Quality and Technology Co., Ltd.

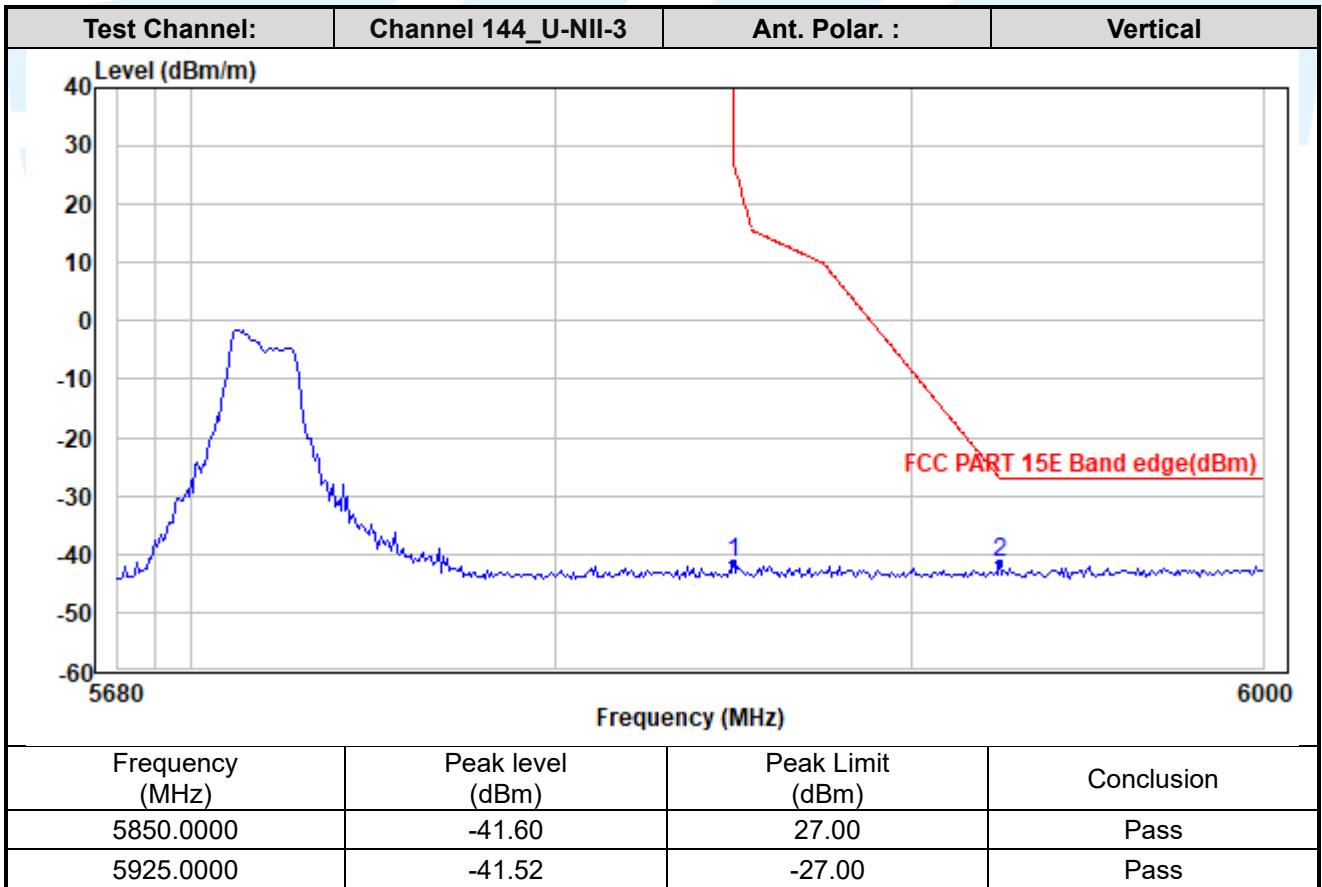
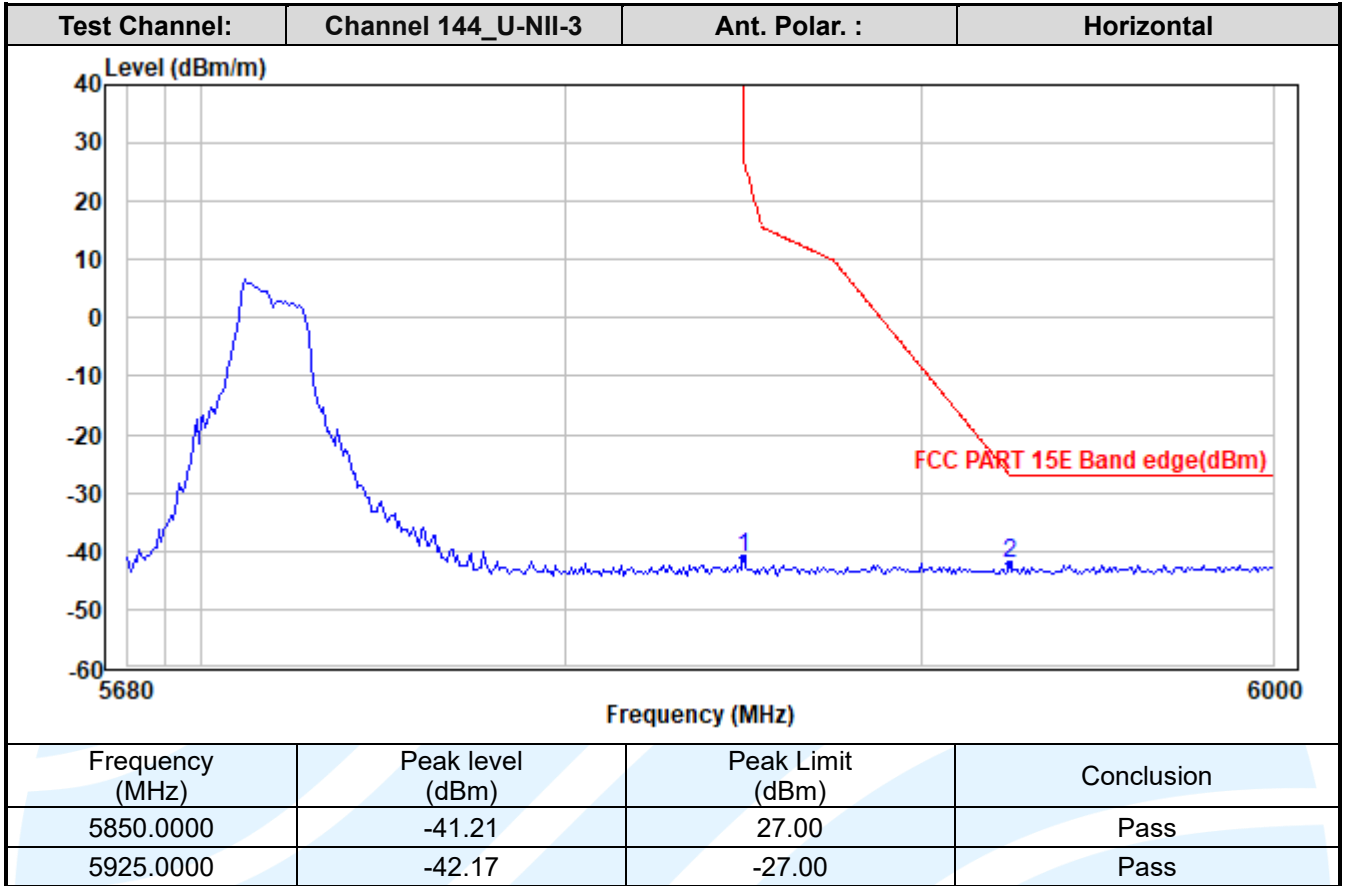

Shenzhen UnionTrust Quality and Technology Co., Ltd.

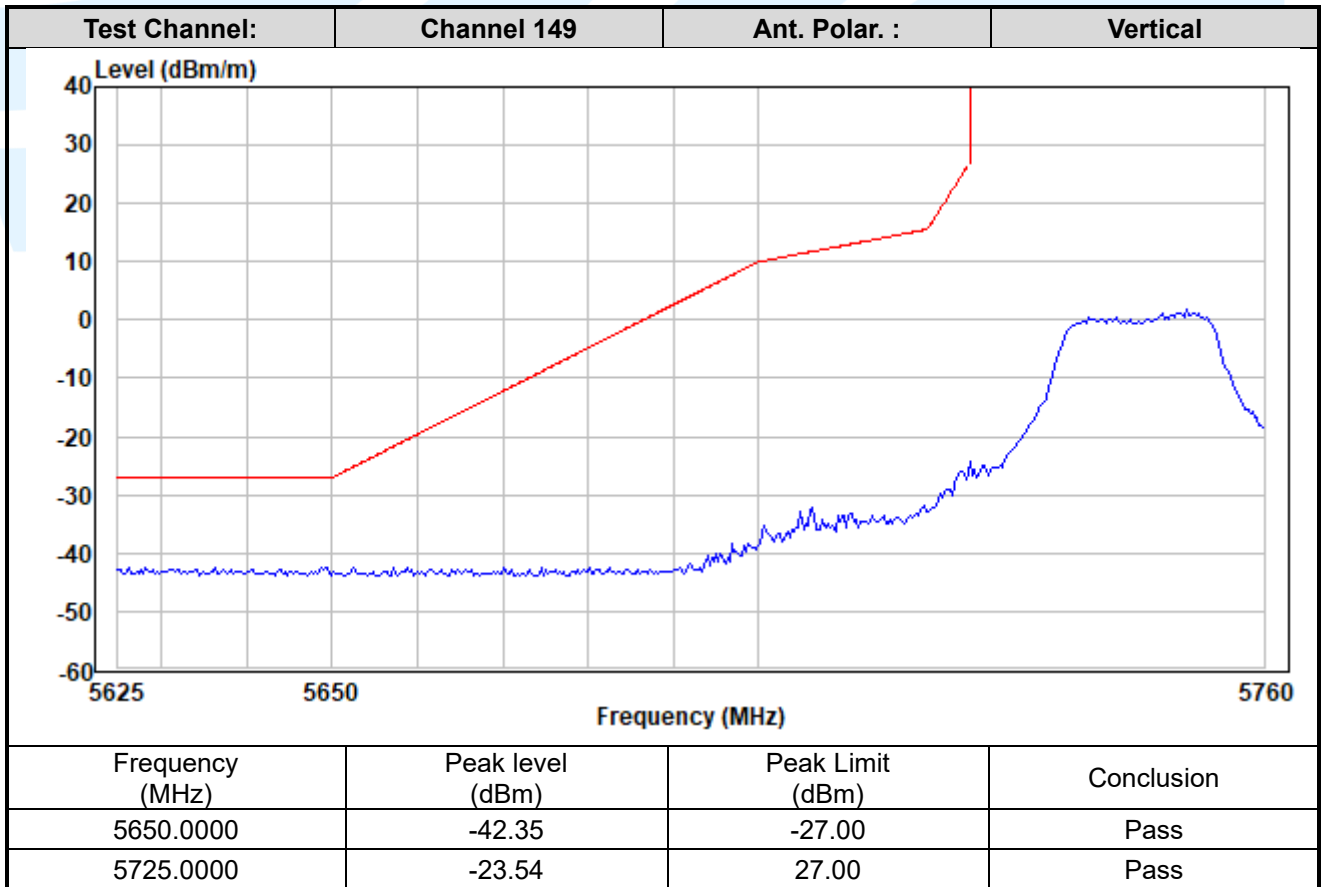
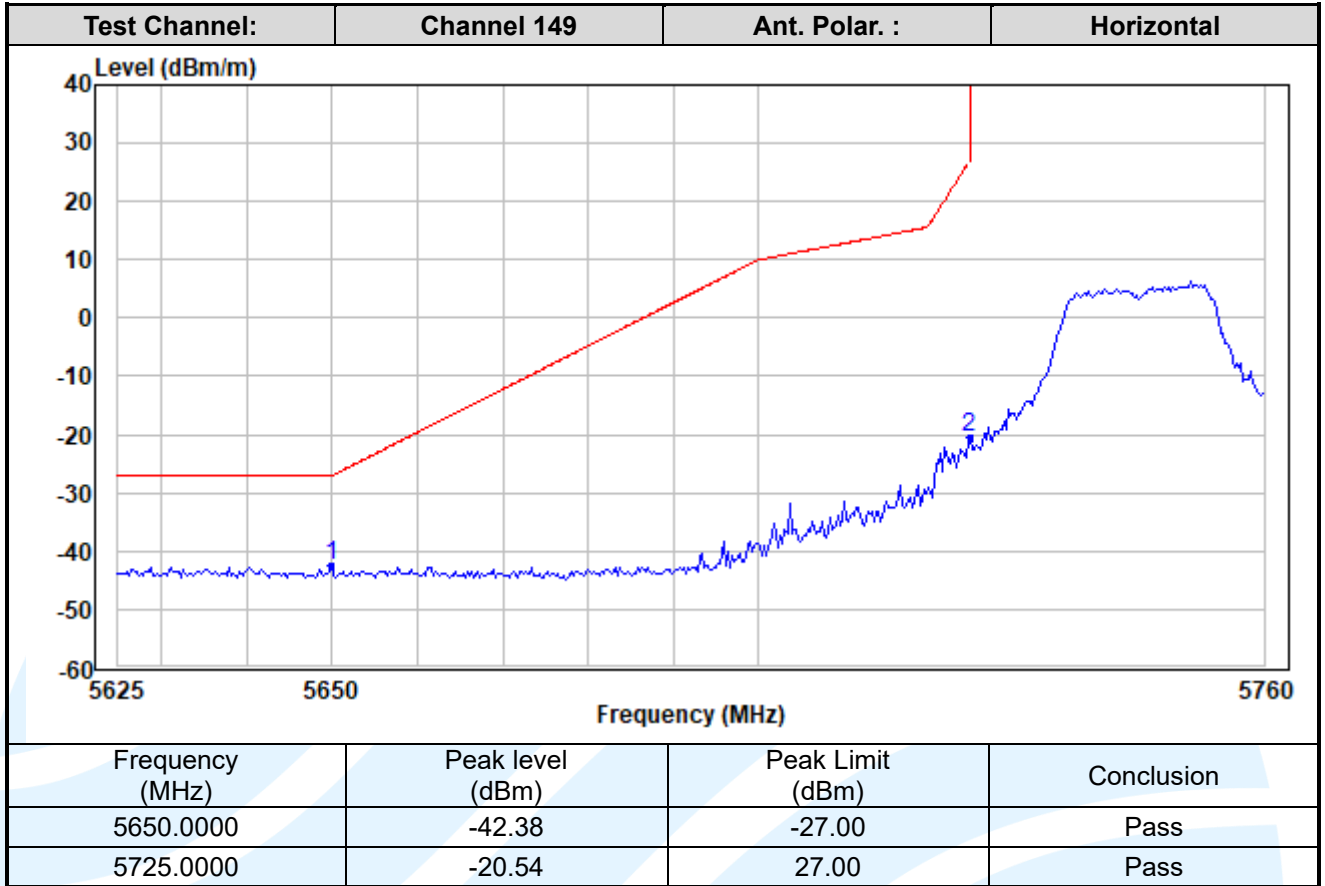

Shenzhen UnionTrust Quality and Technology Co., Ltd.

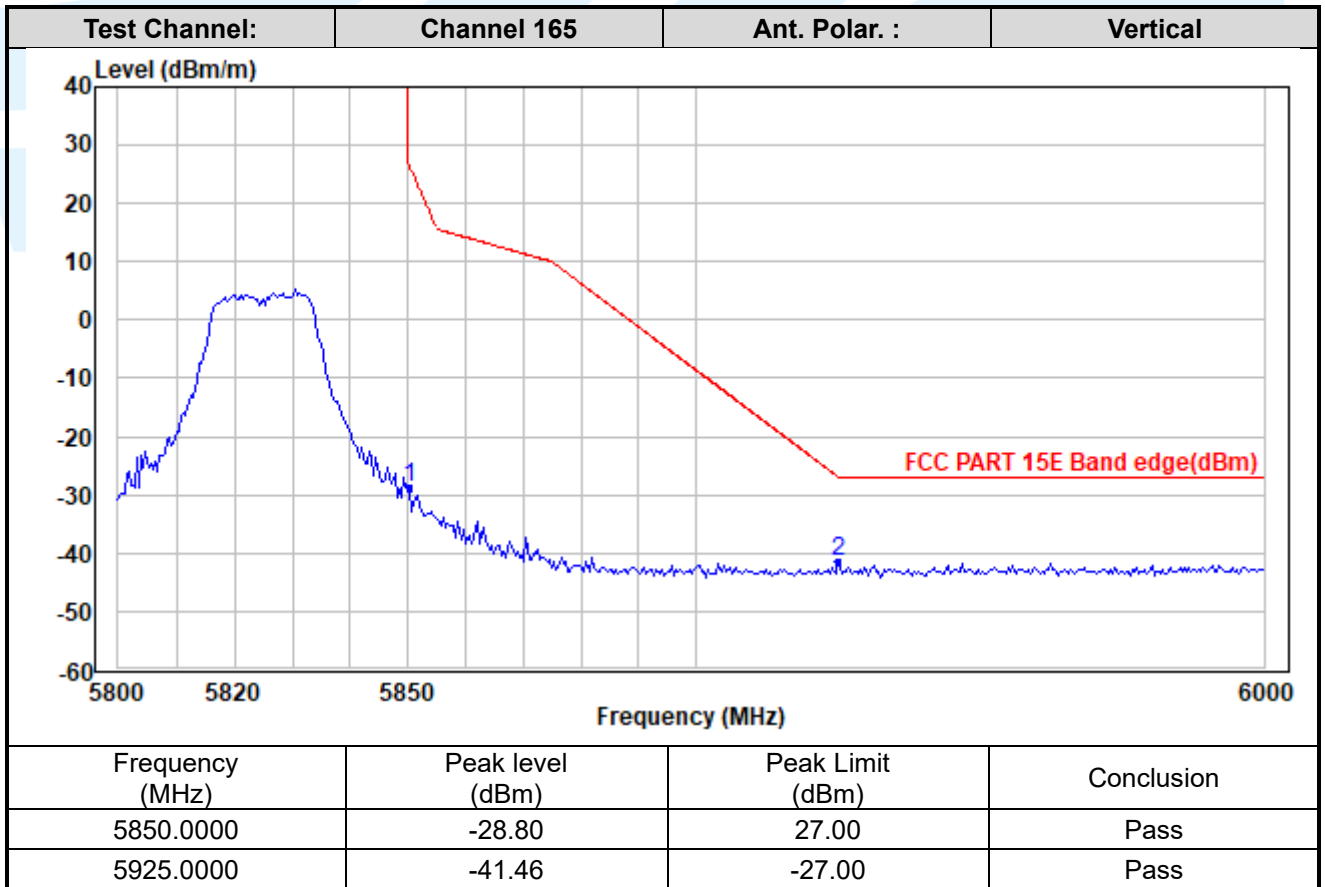
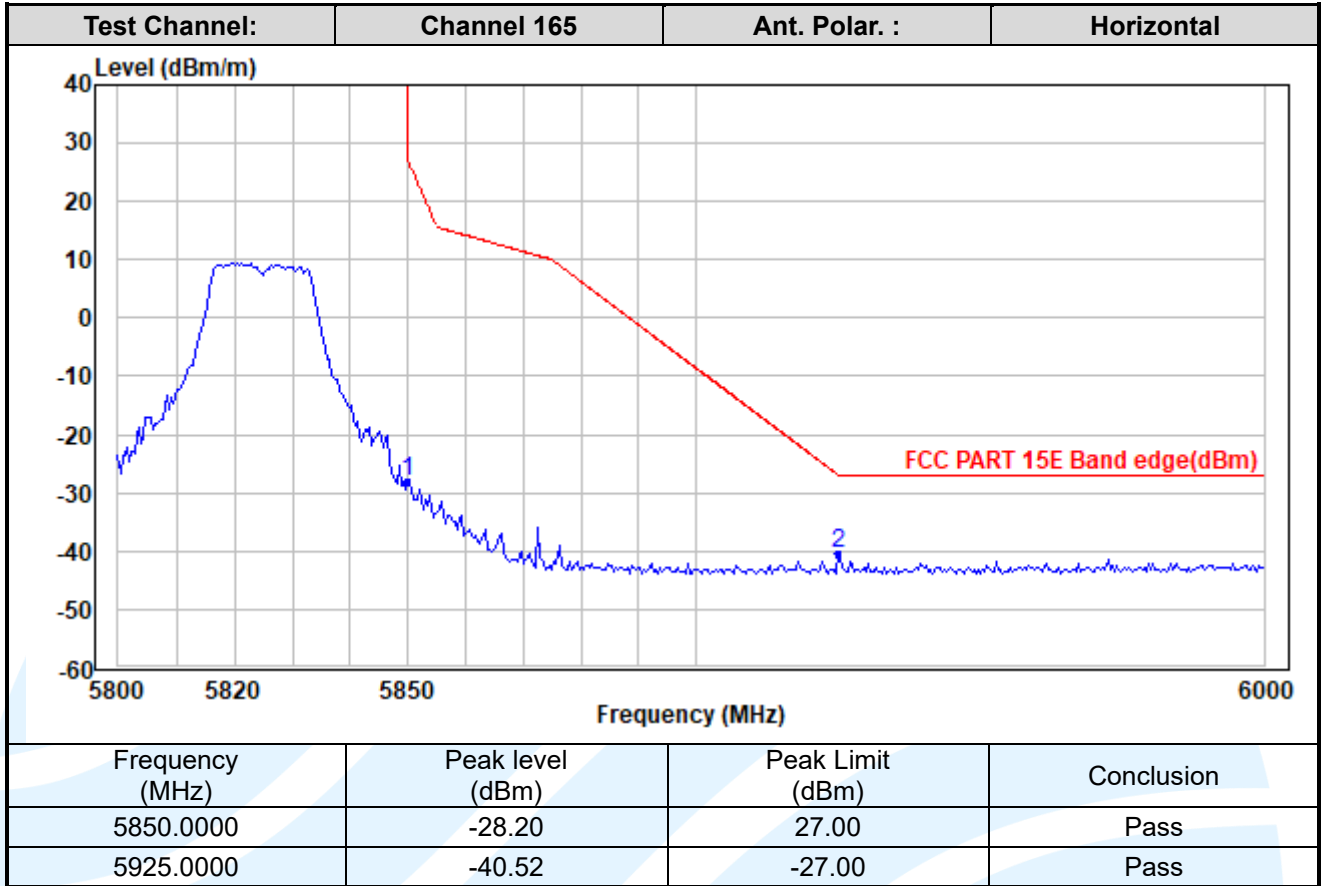

Shenzhen UnionTrust Quality and Technology Co., Ltd.

IEEE 802.11n-HT40

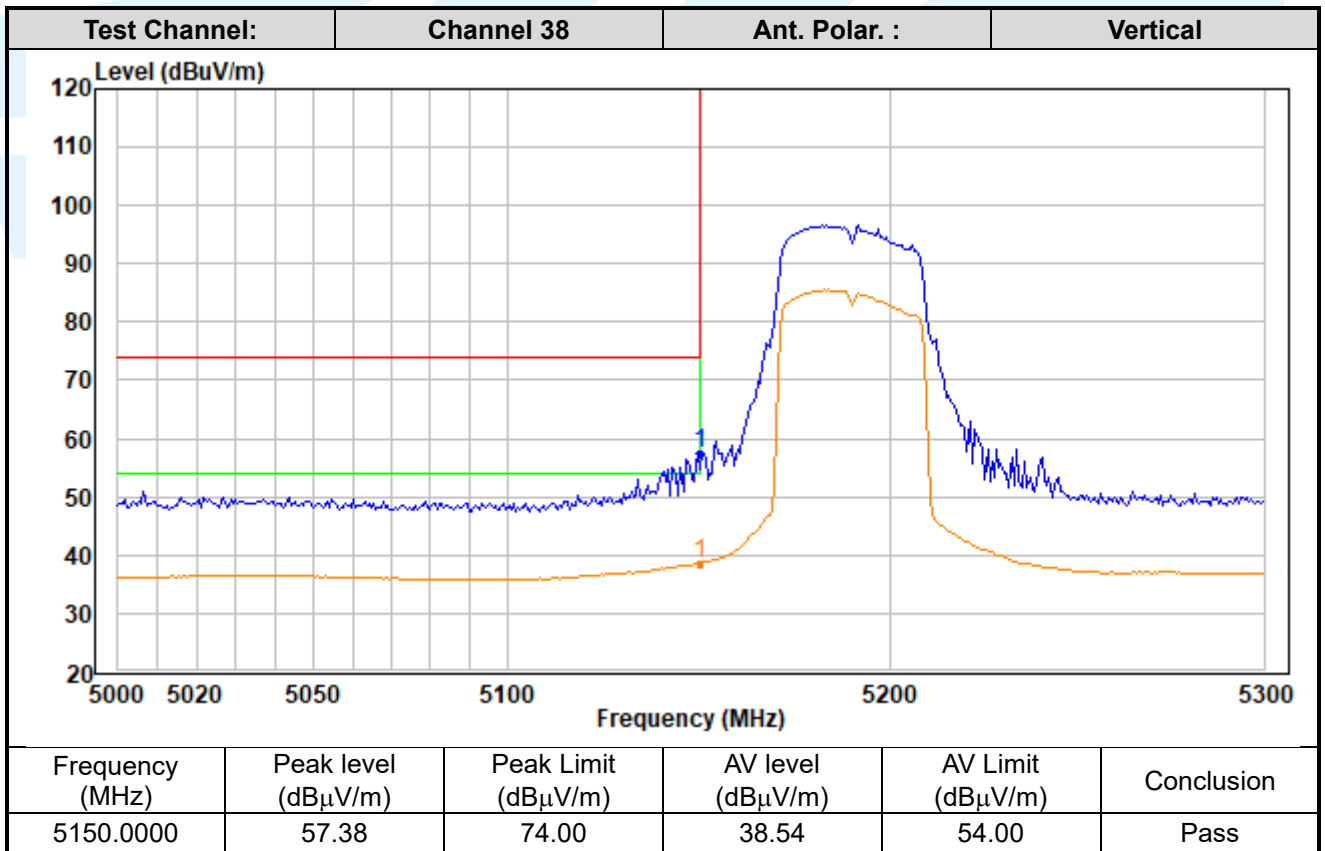
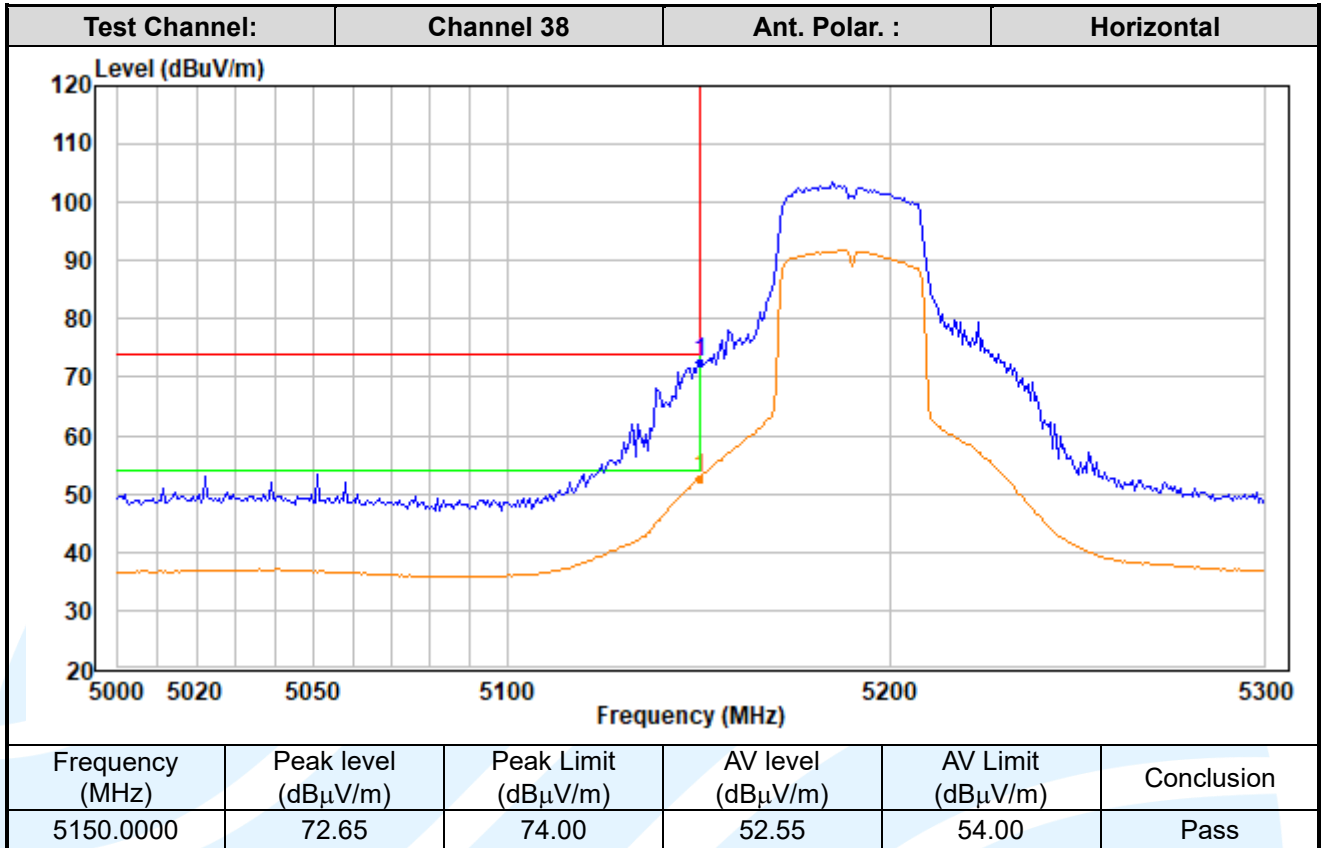

Shenzhen UnionTrust Quality and Technology Co., Ltd.

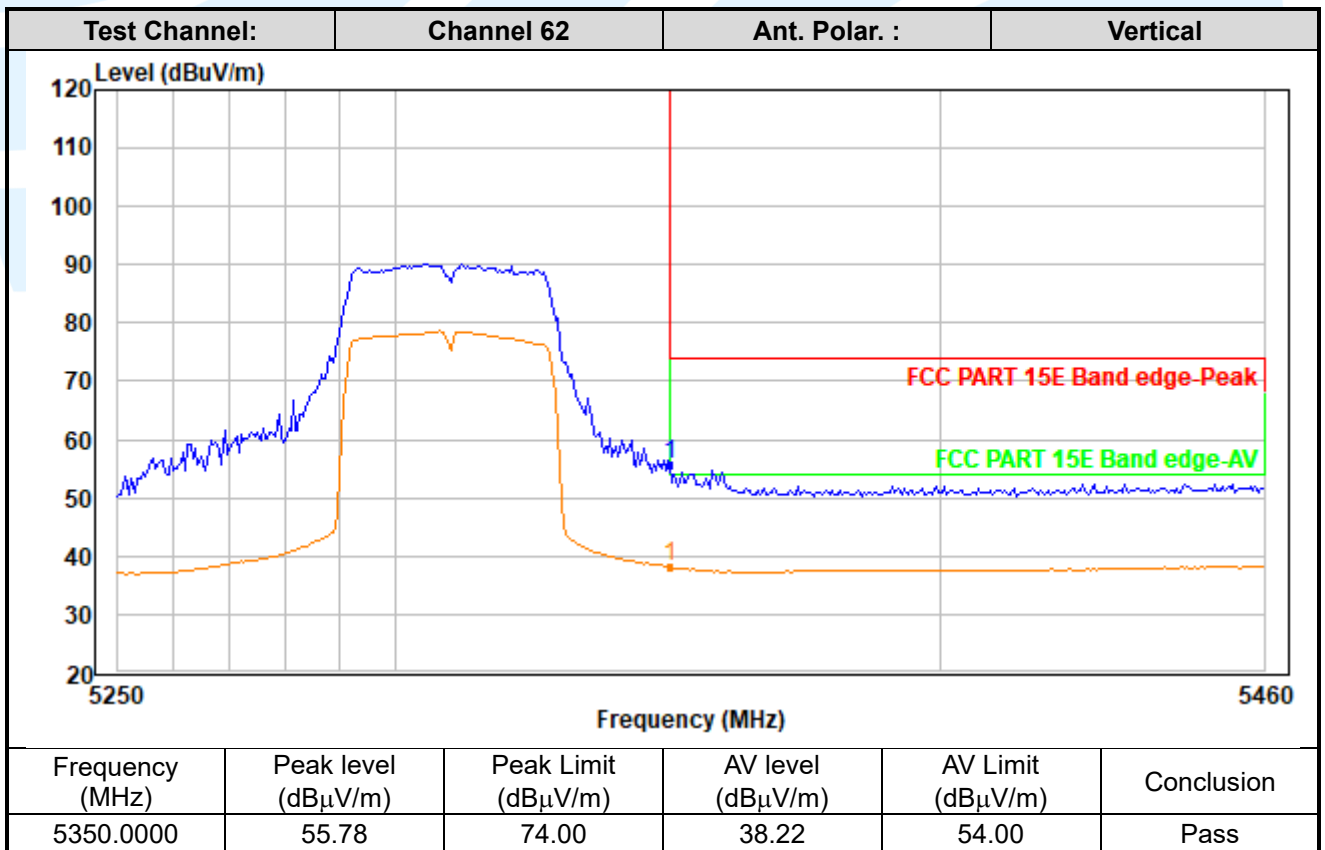
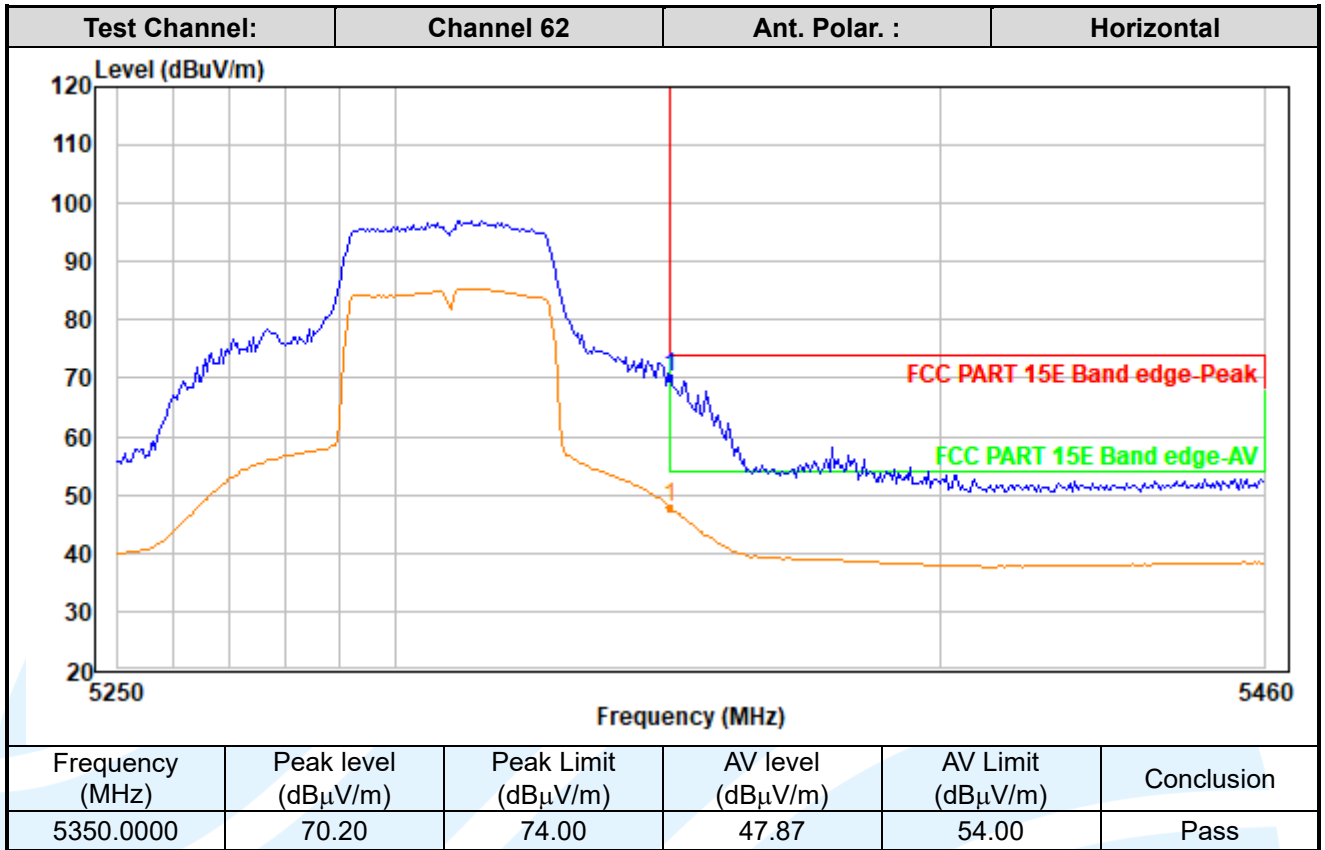

Shenzhen UnionTrust Quality and Technology Co., Ltd.

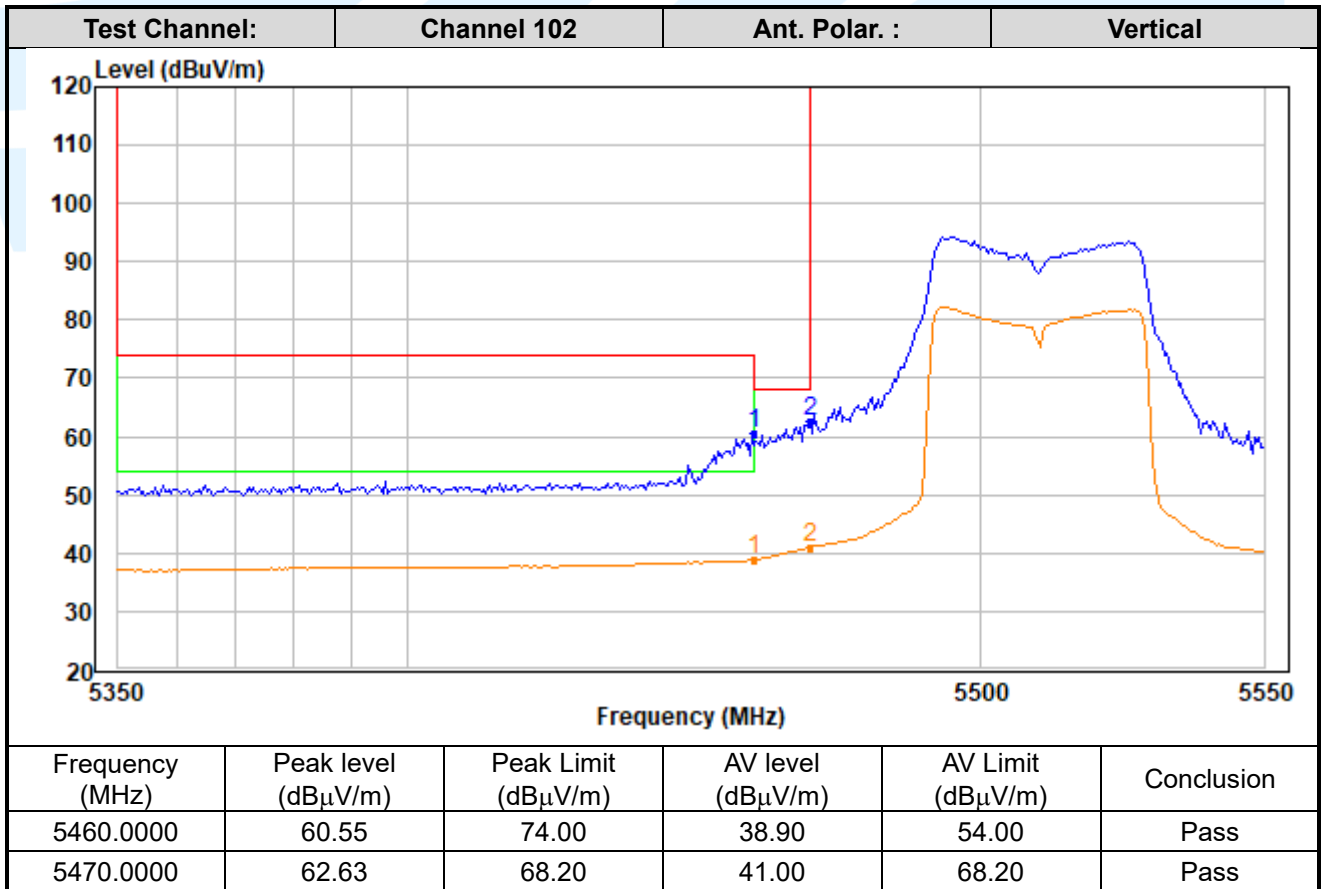
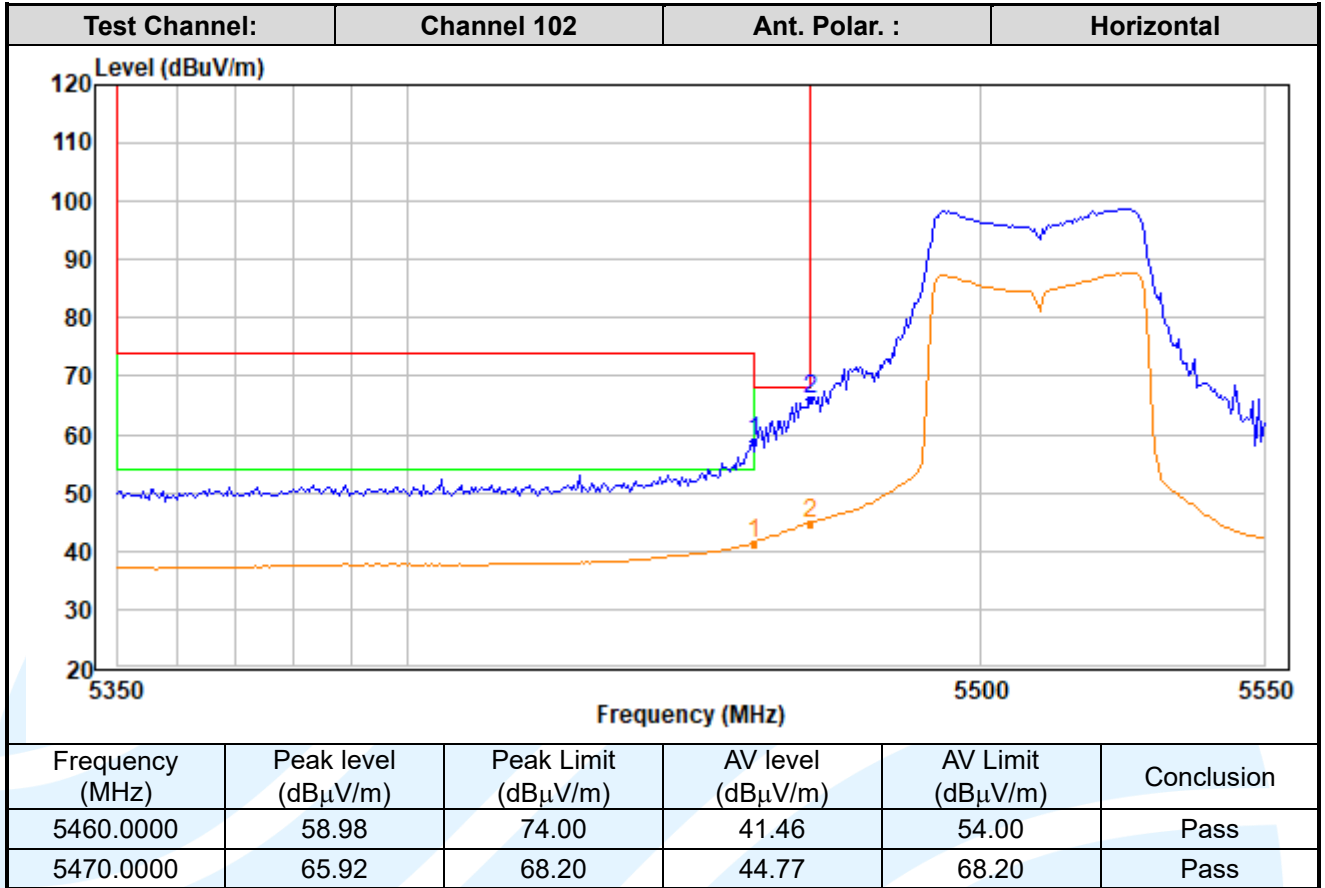

Shenzhen UnionTrust Quality and Technology Co., Ltd.

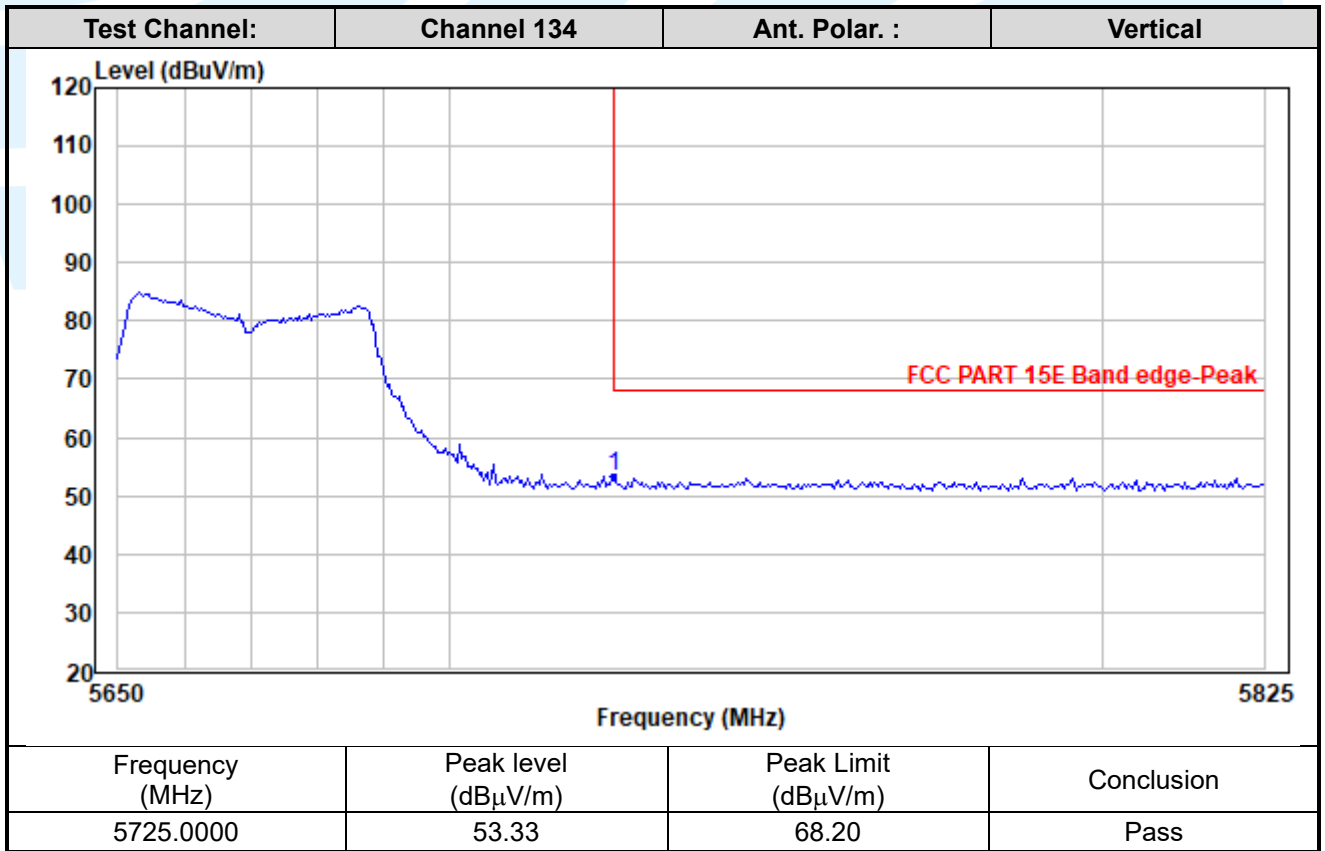
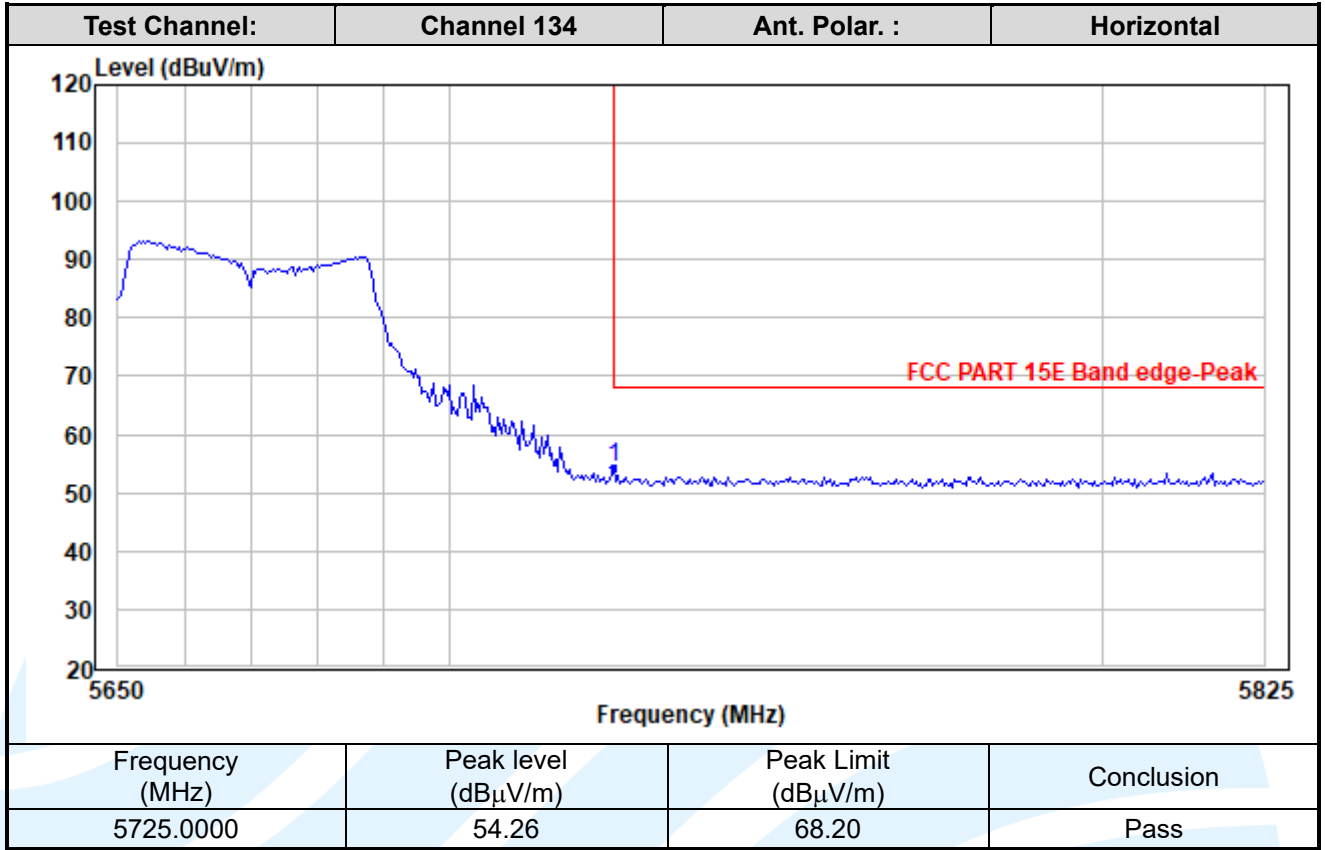

Shenzhen UnionTrust Quality and Technology Co., Ltd.

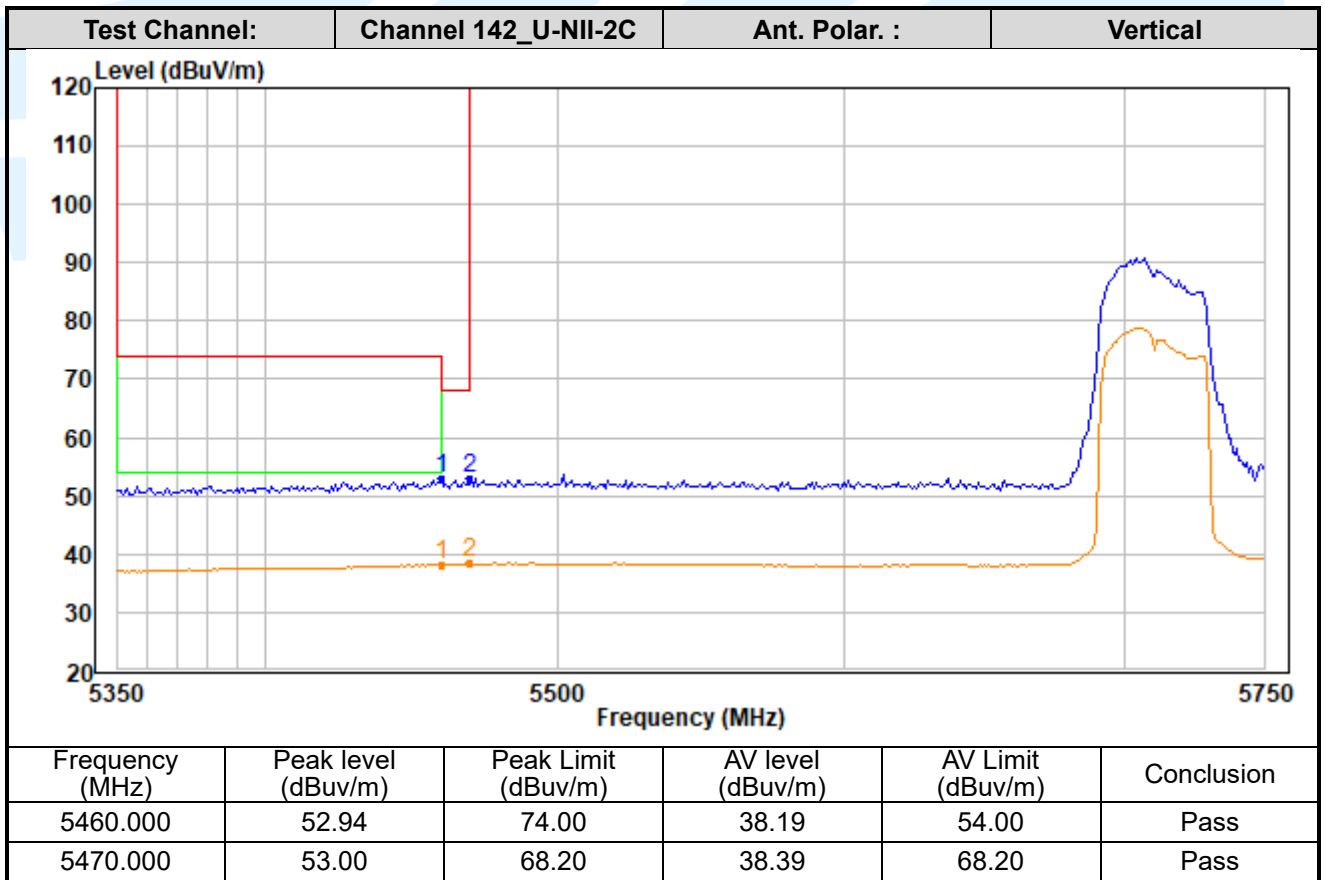
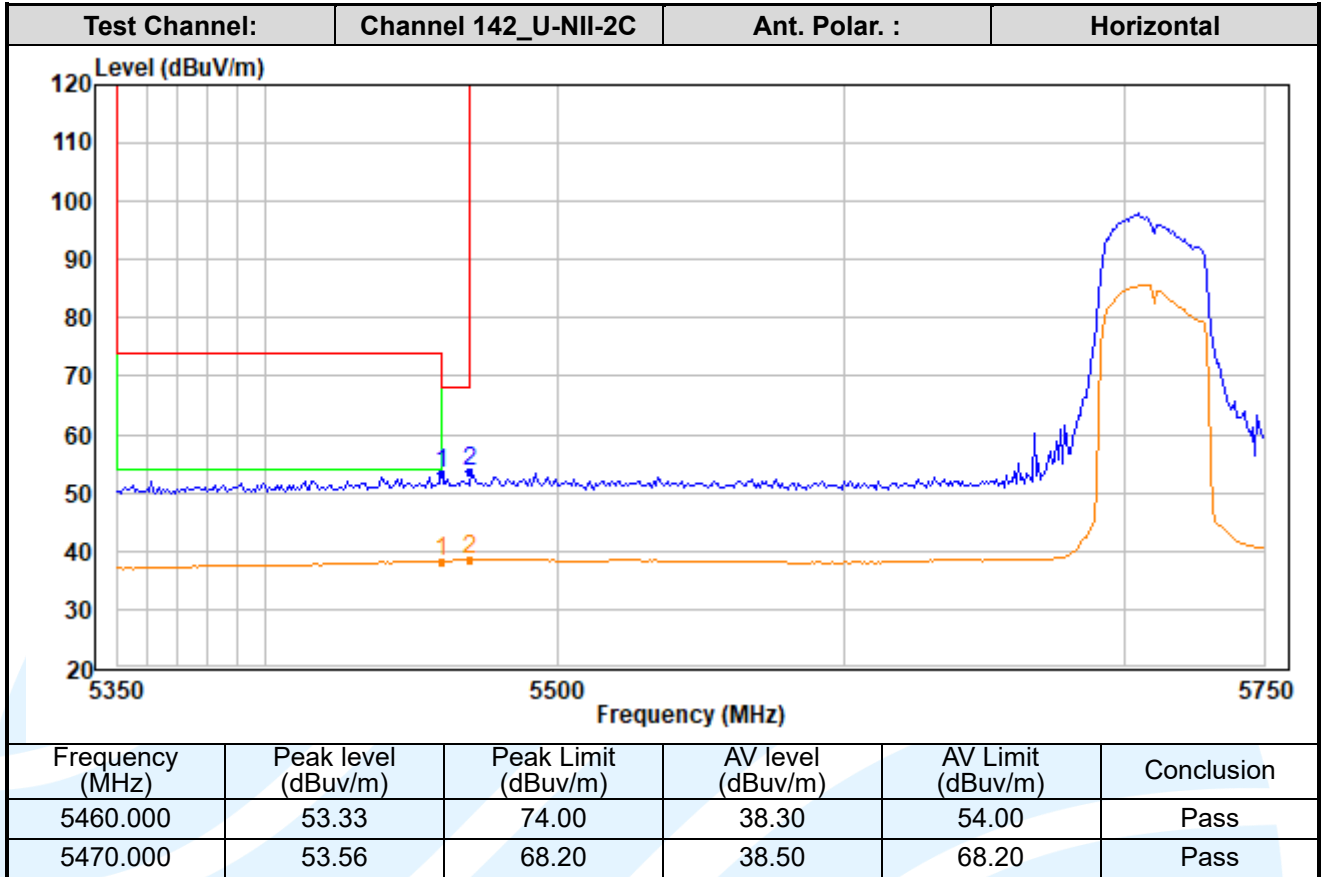

Shenzhen UnionTrust Quality and Technology Co., Ltd.

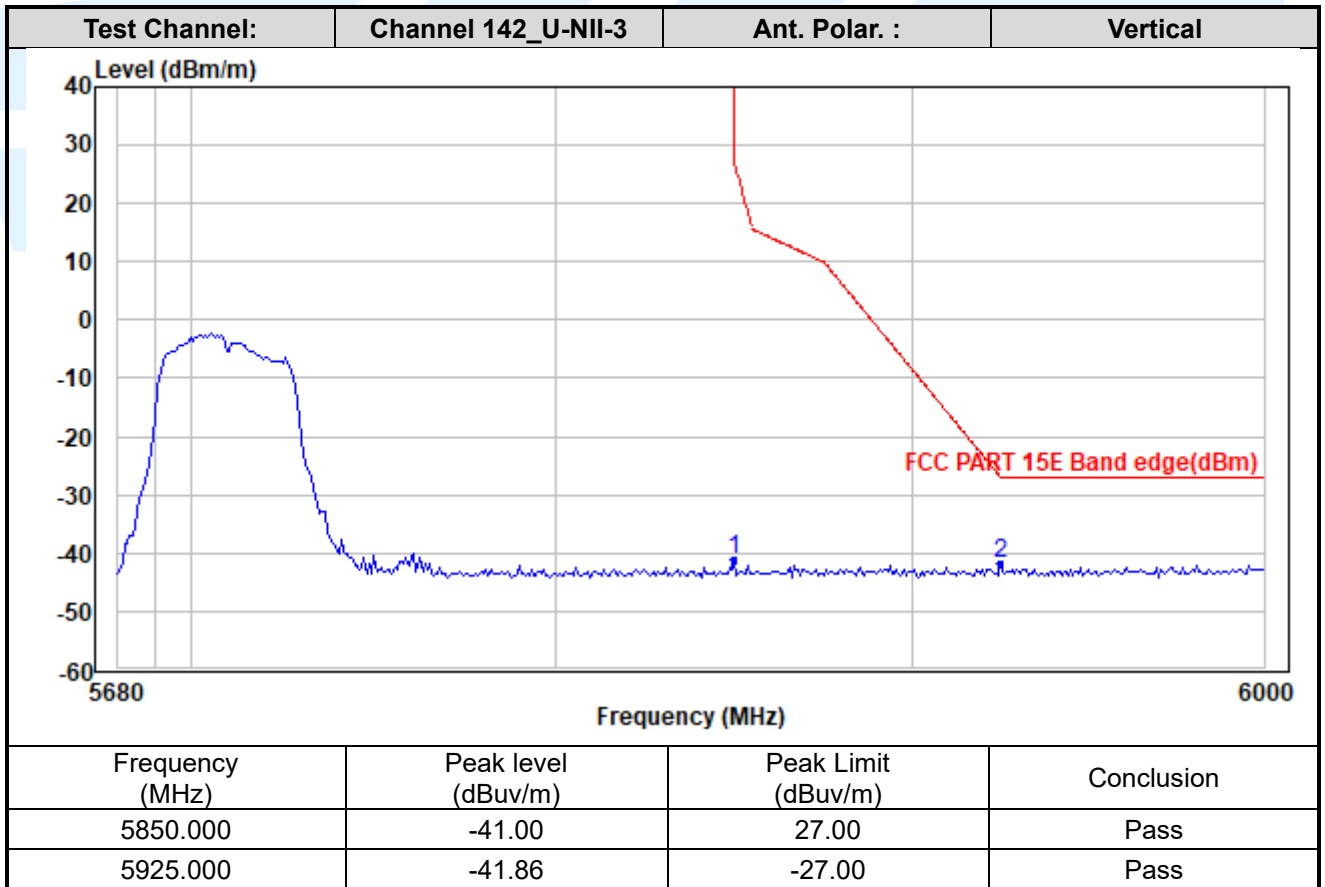
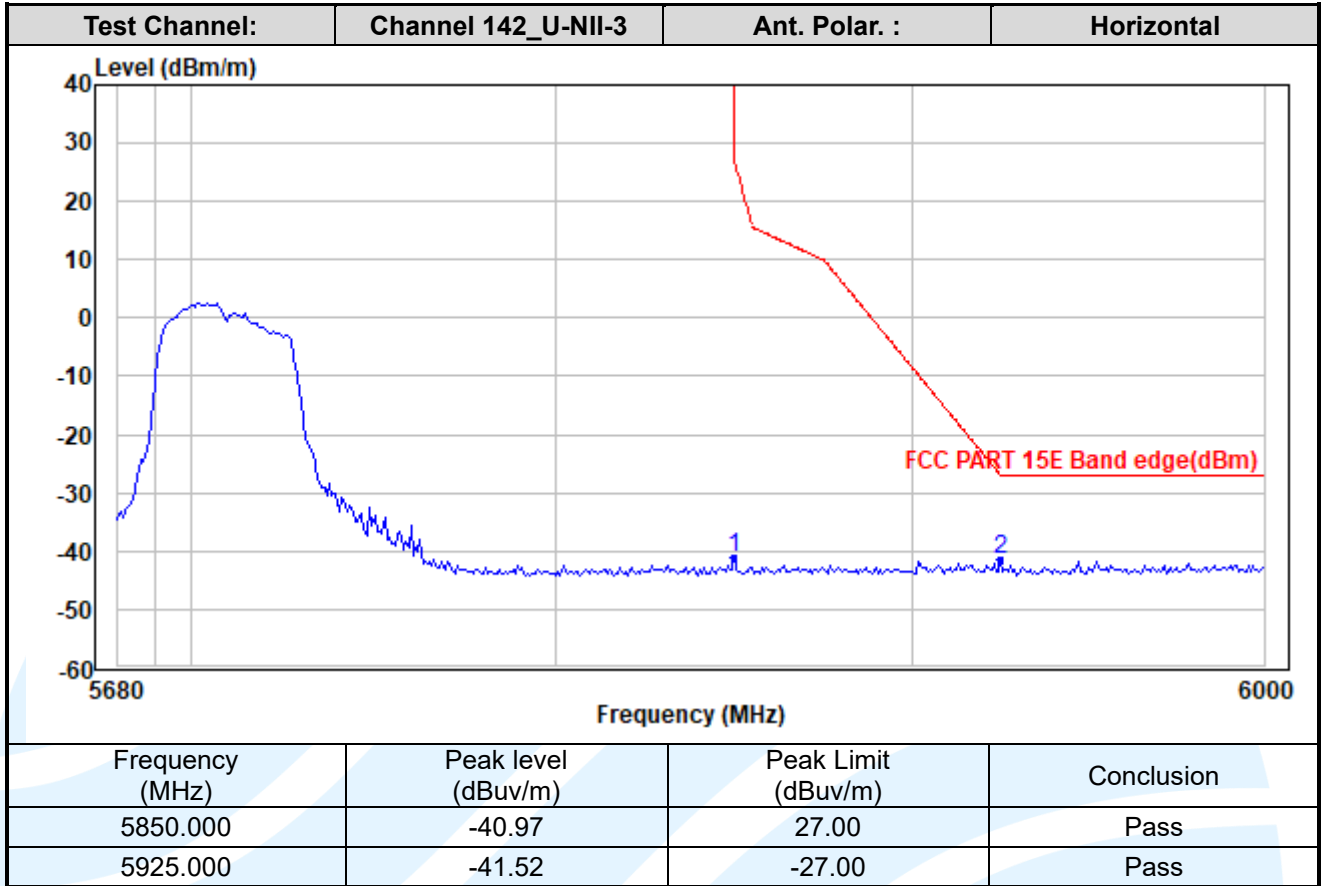

Shenzhen UnionTrust Quality and Technology Co., Ltd.

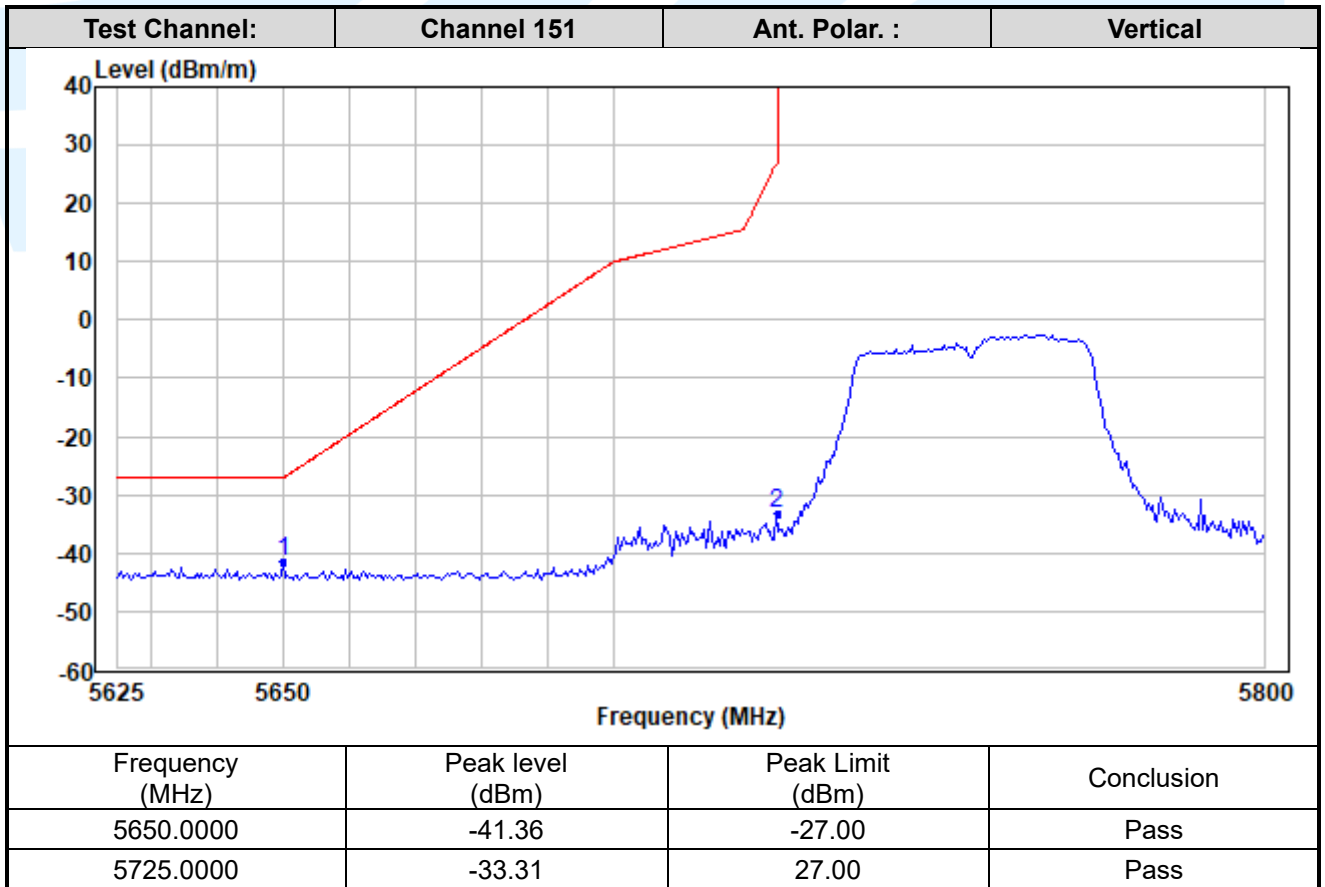
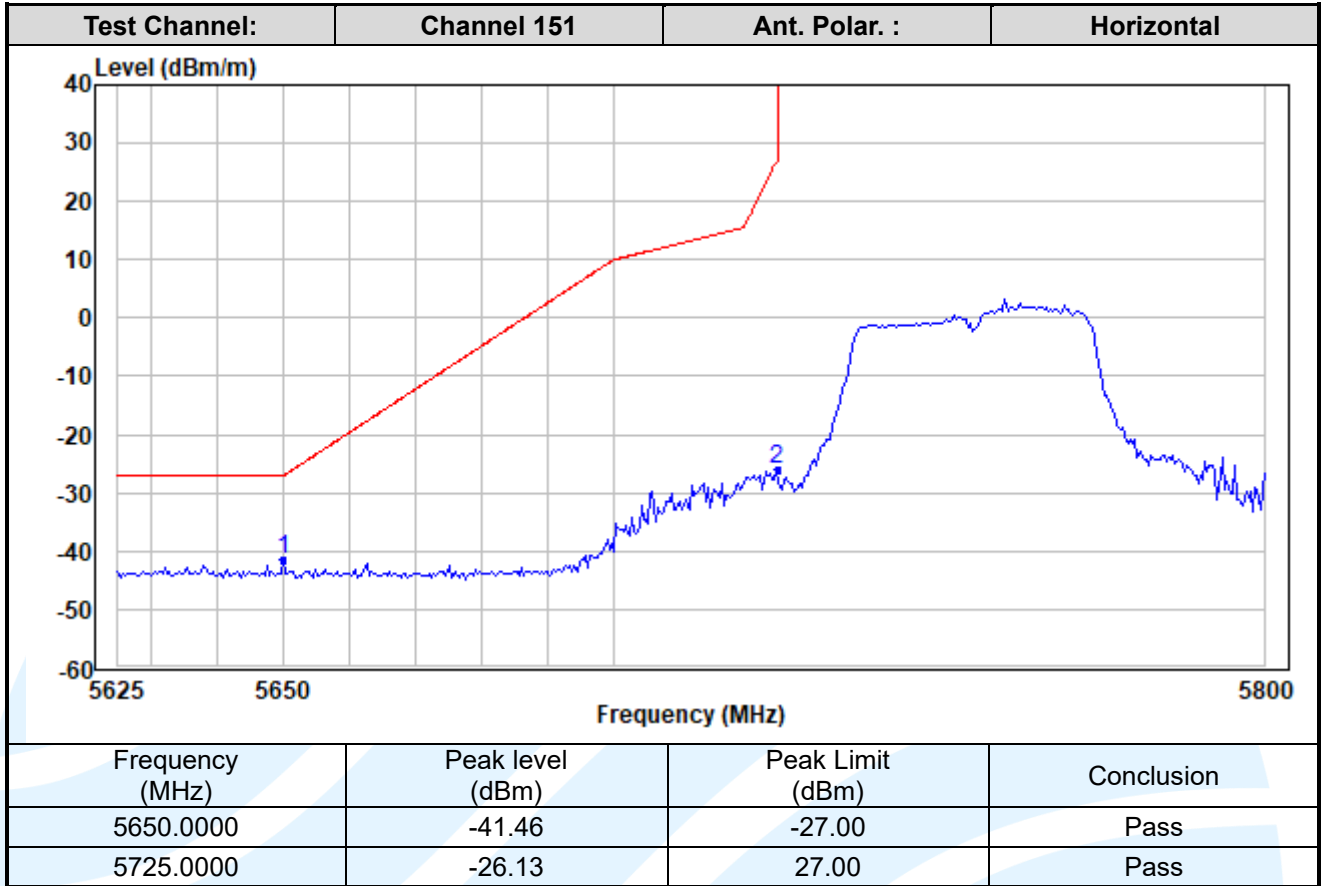

Shenzhen UnionTrust Quality and Technology Co., Ltd.

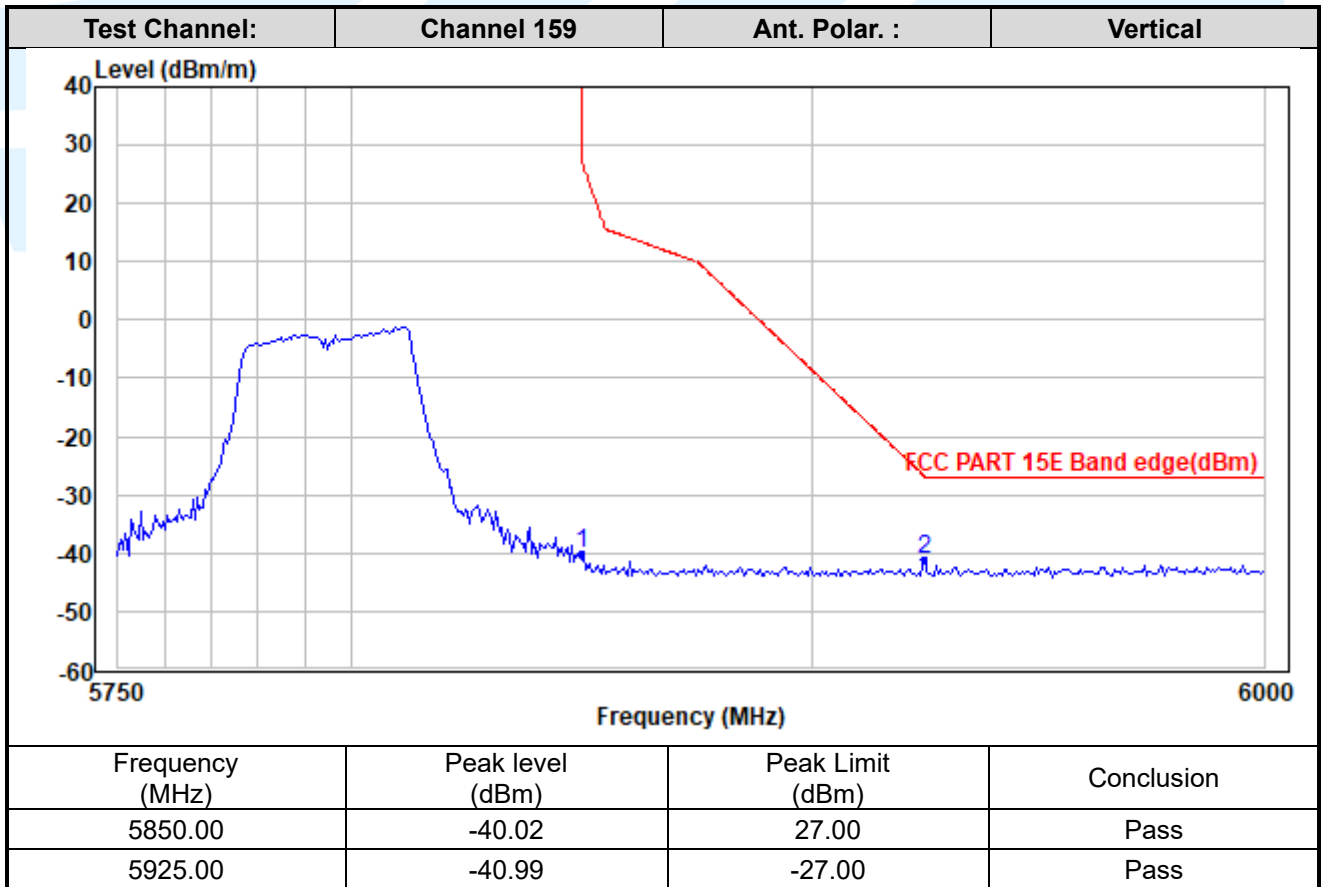
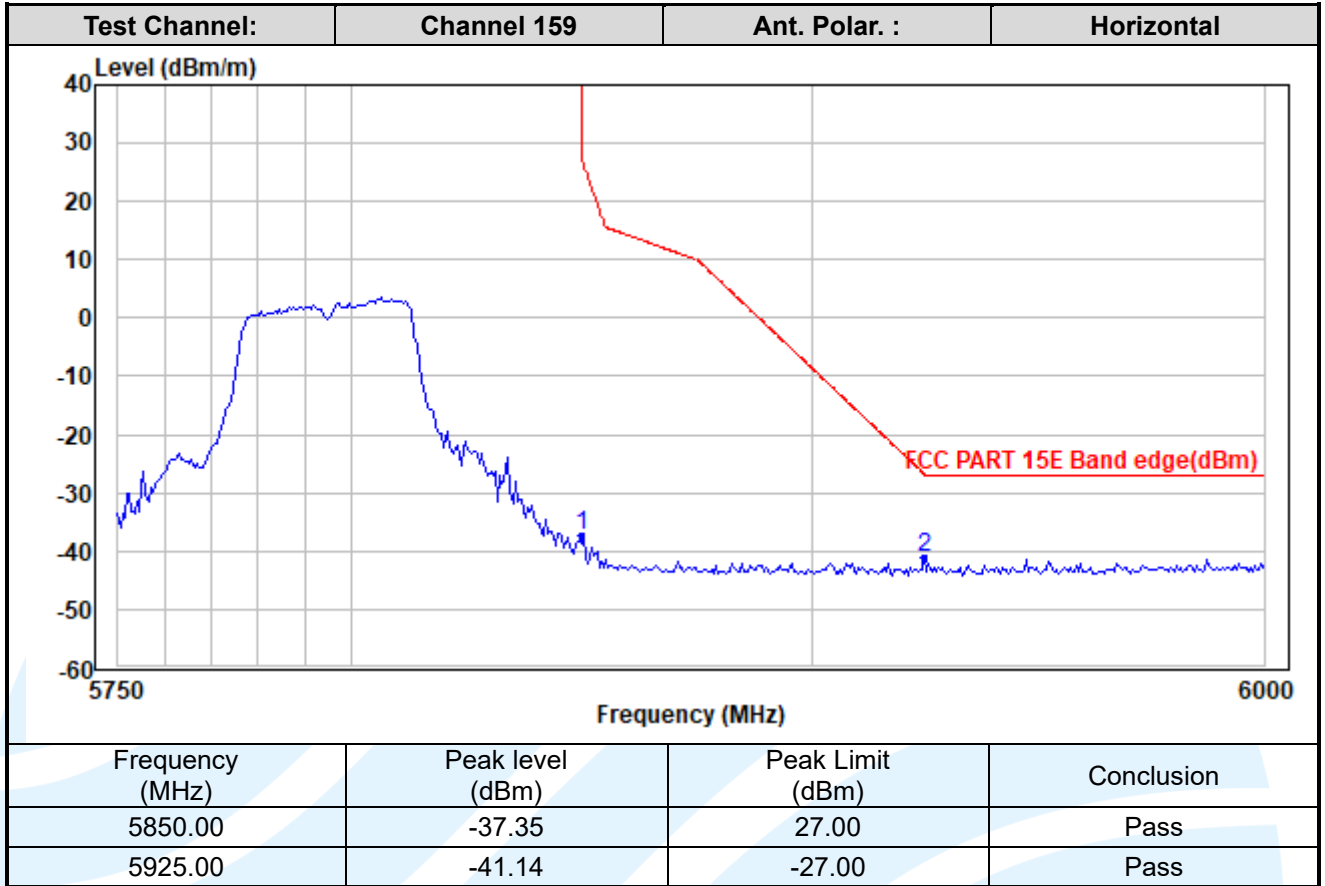

Shenzhen UnionTrust Quality and Technology Co., Ltd.

IEEE 802.11ax-HE20

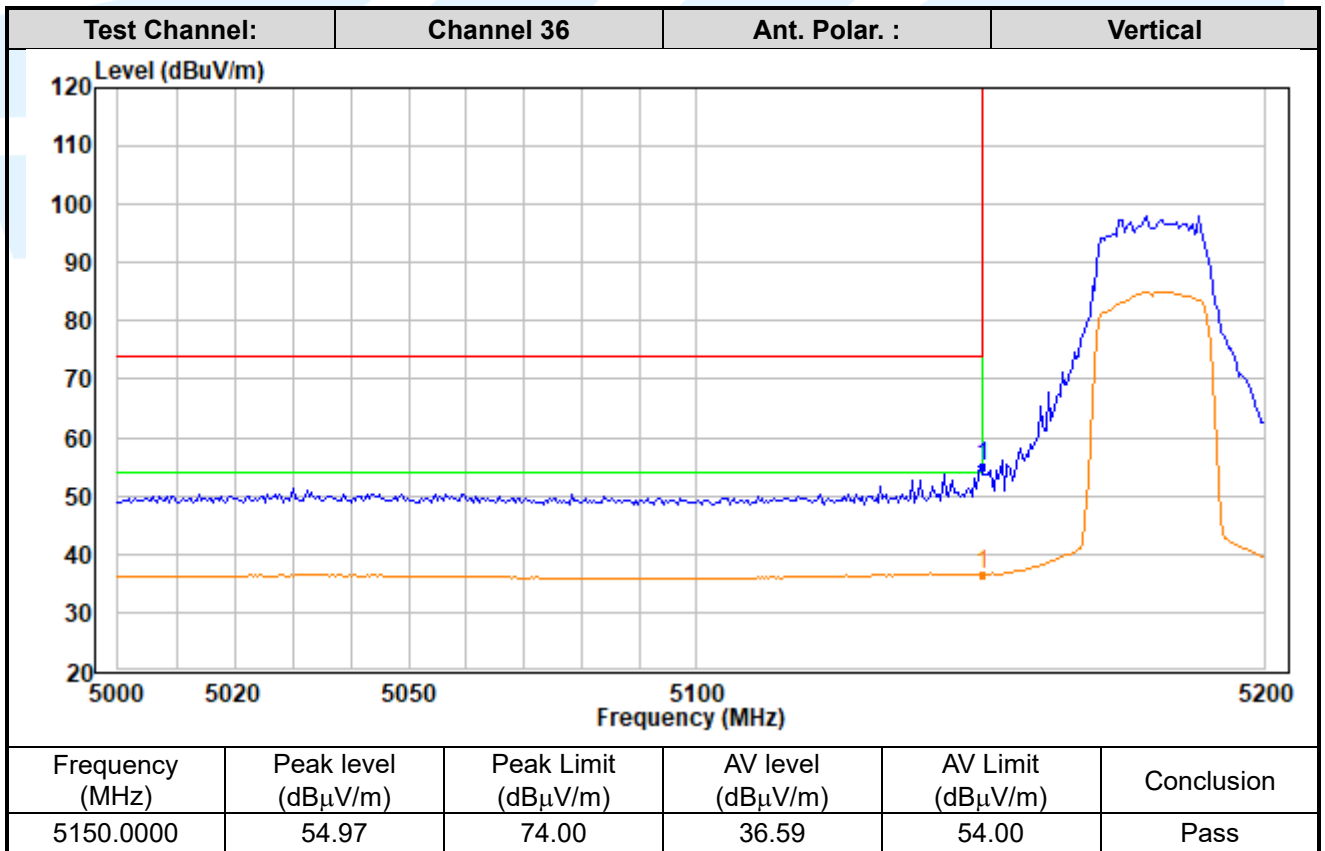
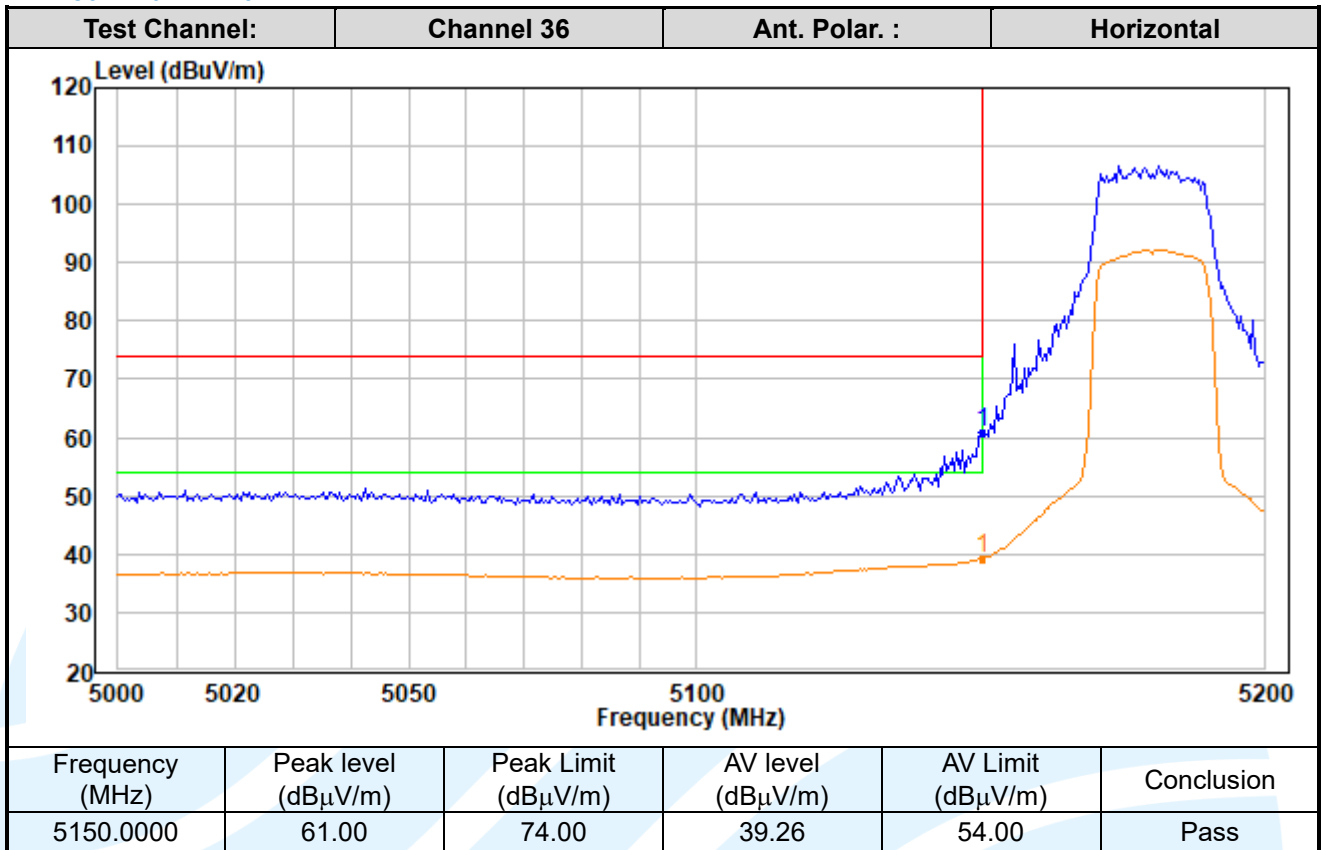

Shenzhen UnionTrust Quality and Technology Co., Ltd.

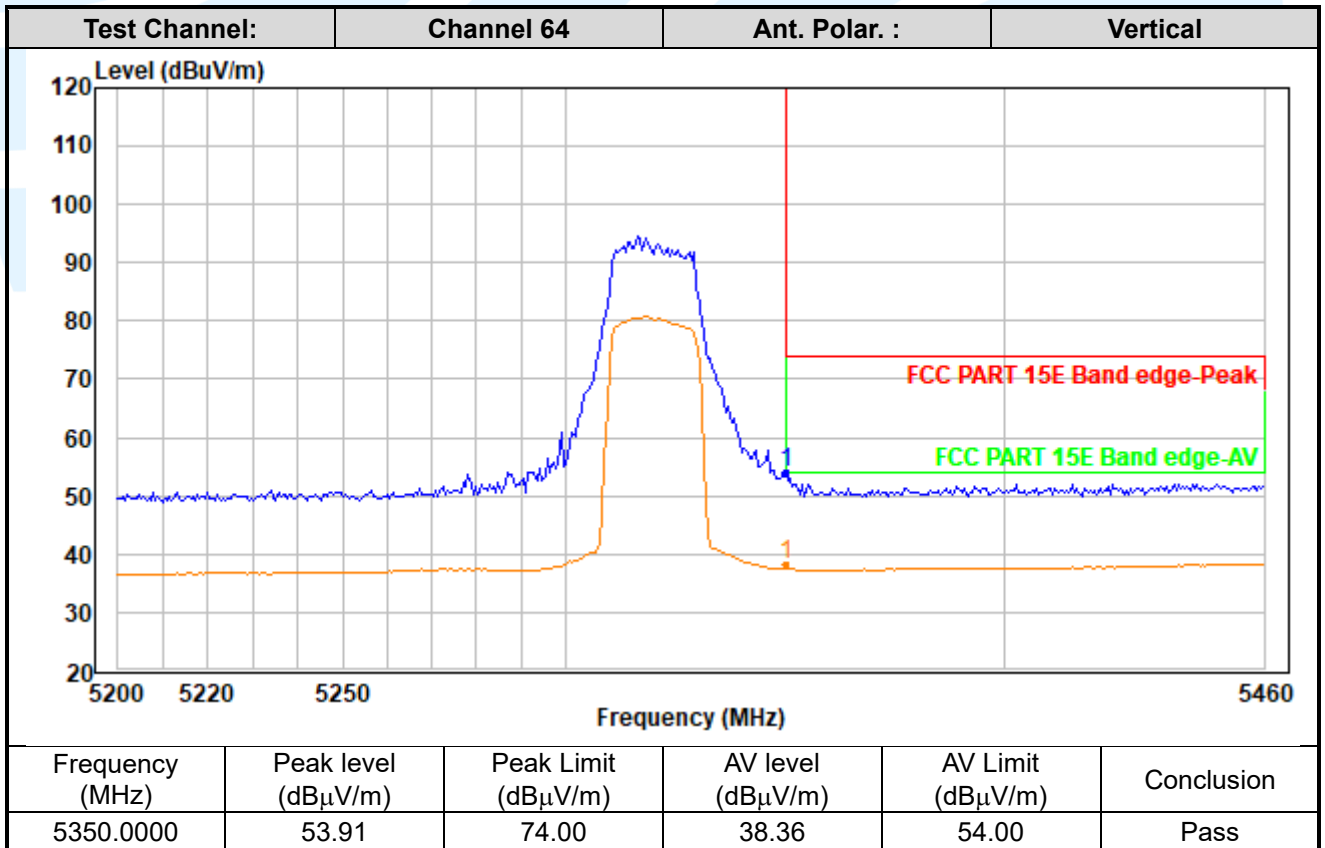
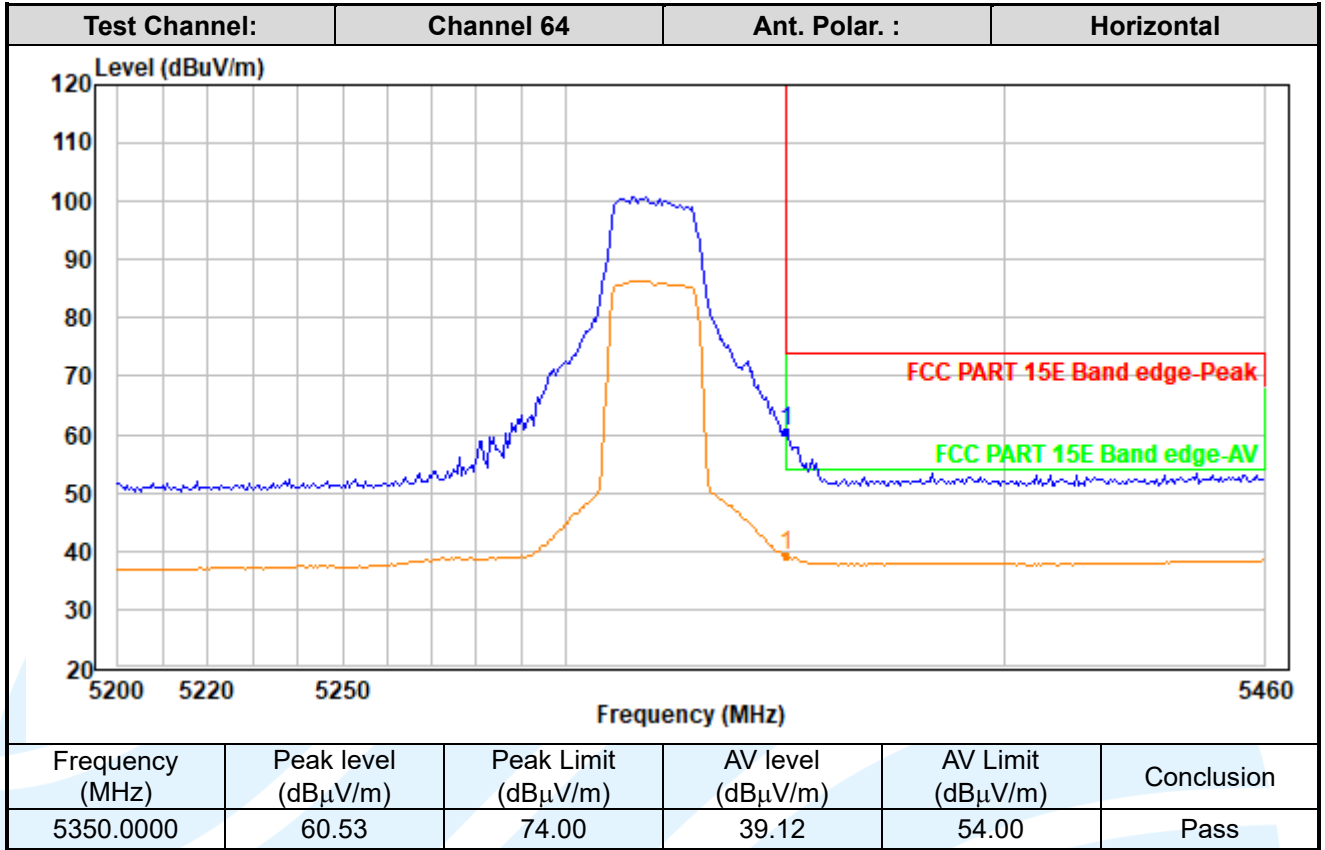

Shenzhen UnionTrust Quality and Technology Co., Ltd.

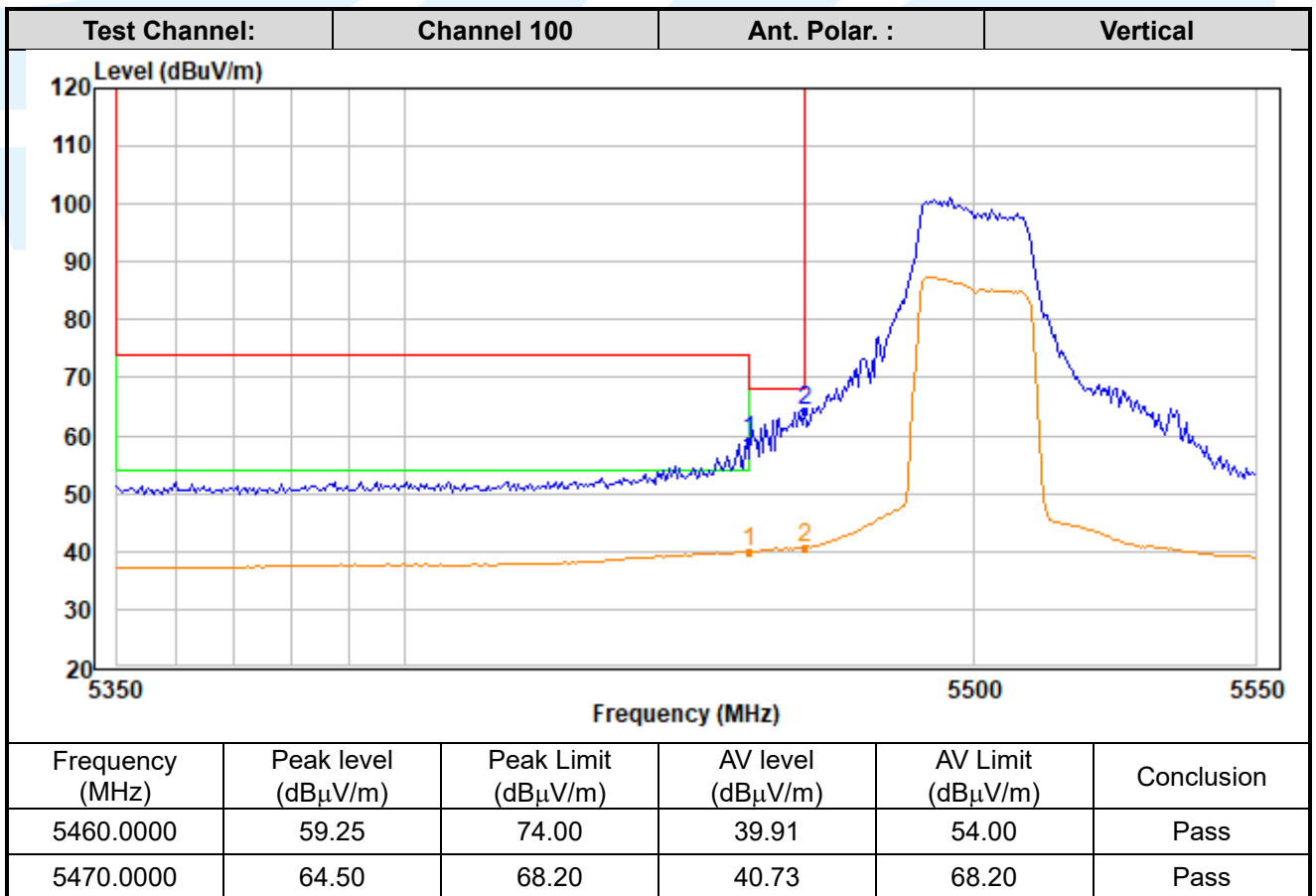
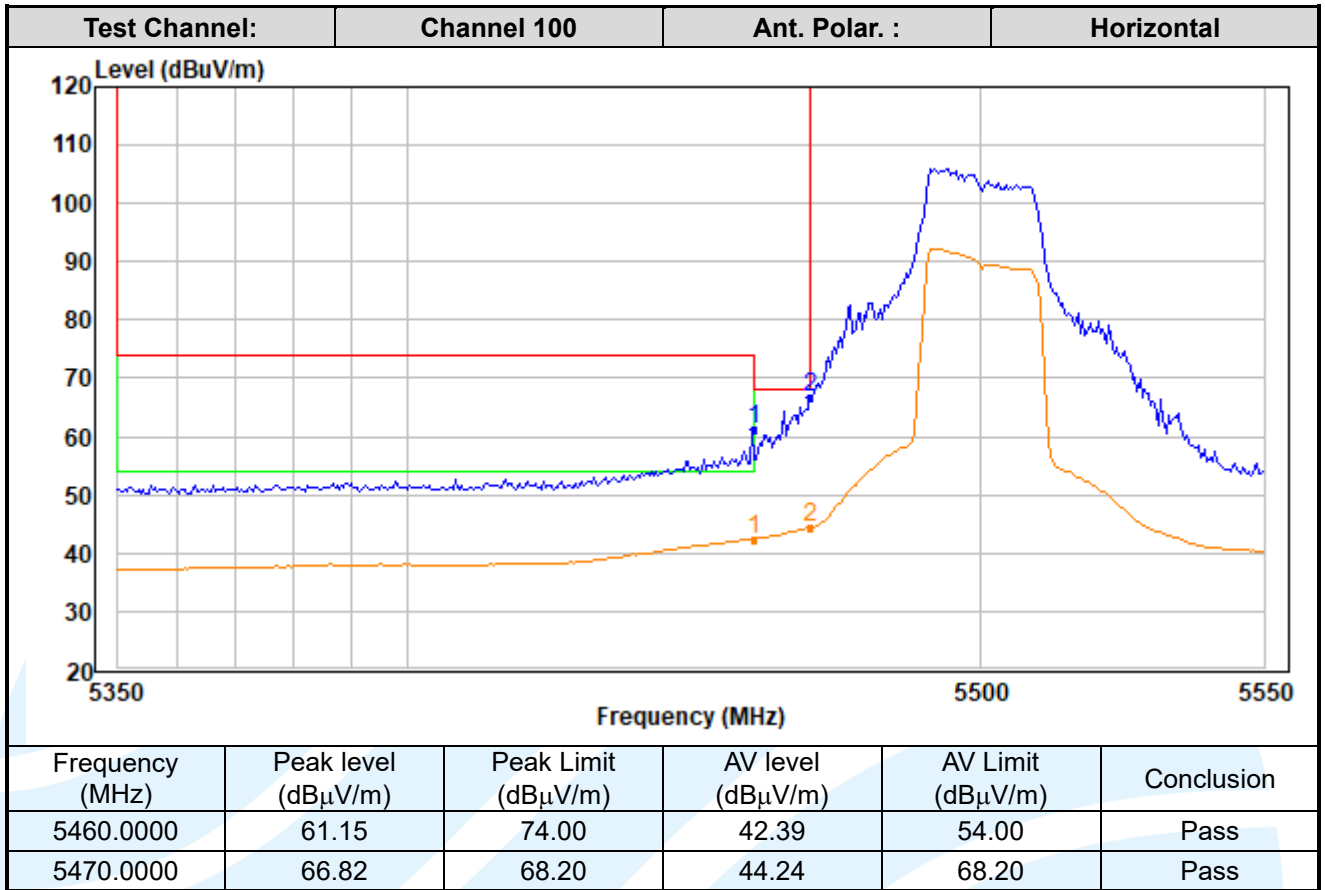

Shenzhen UnionTrust Quality and Technology Co., Ltd.

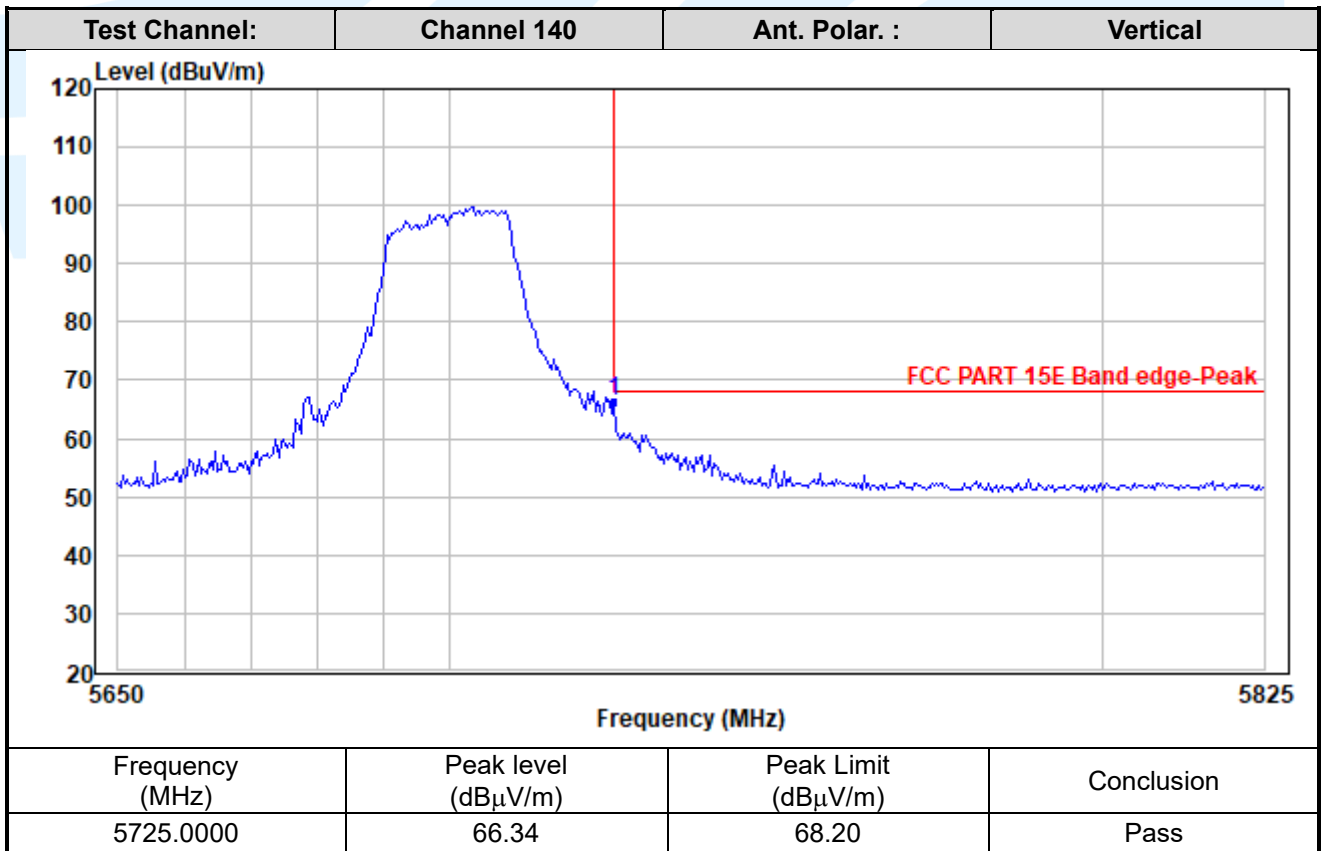
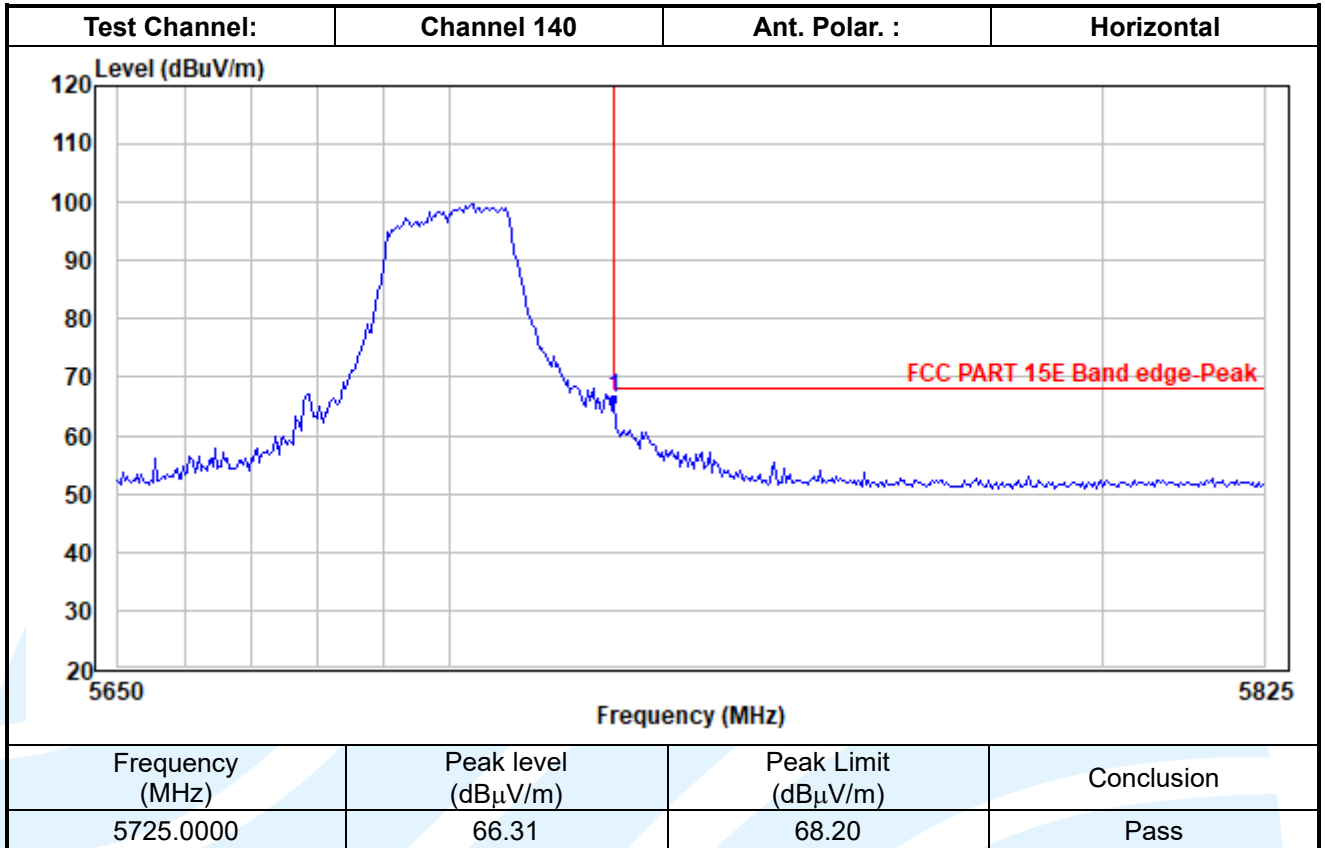

Shenzhen UnionTrust Quality and Technology Co., Ltd.

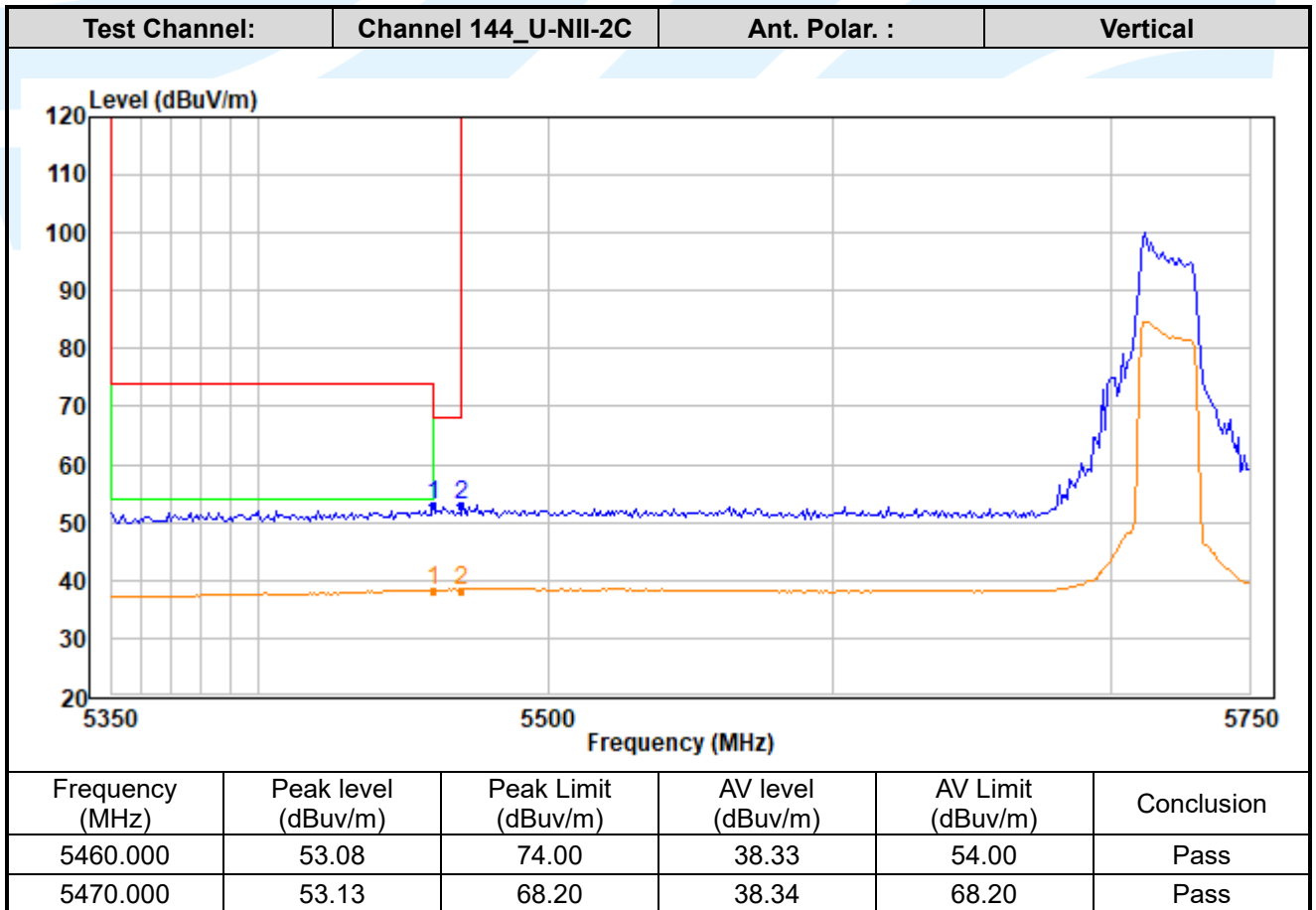
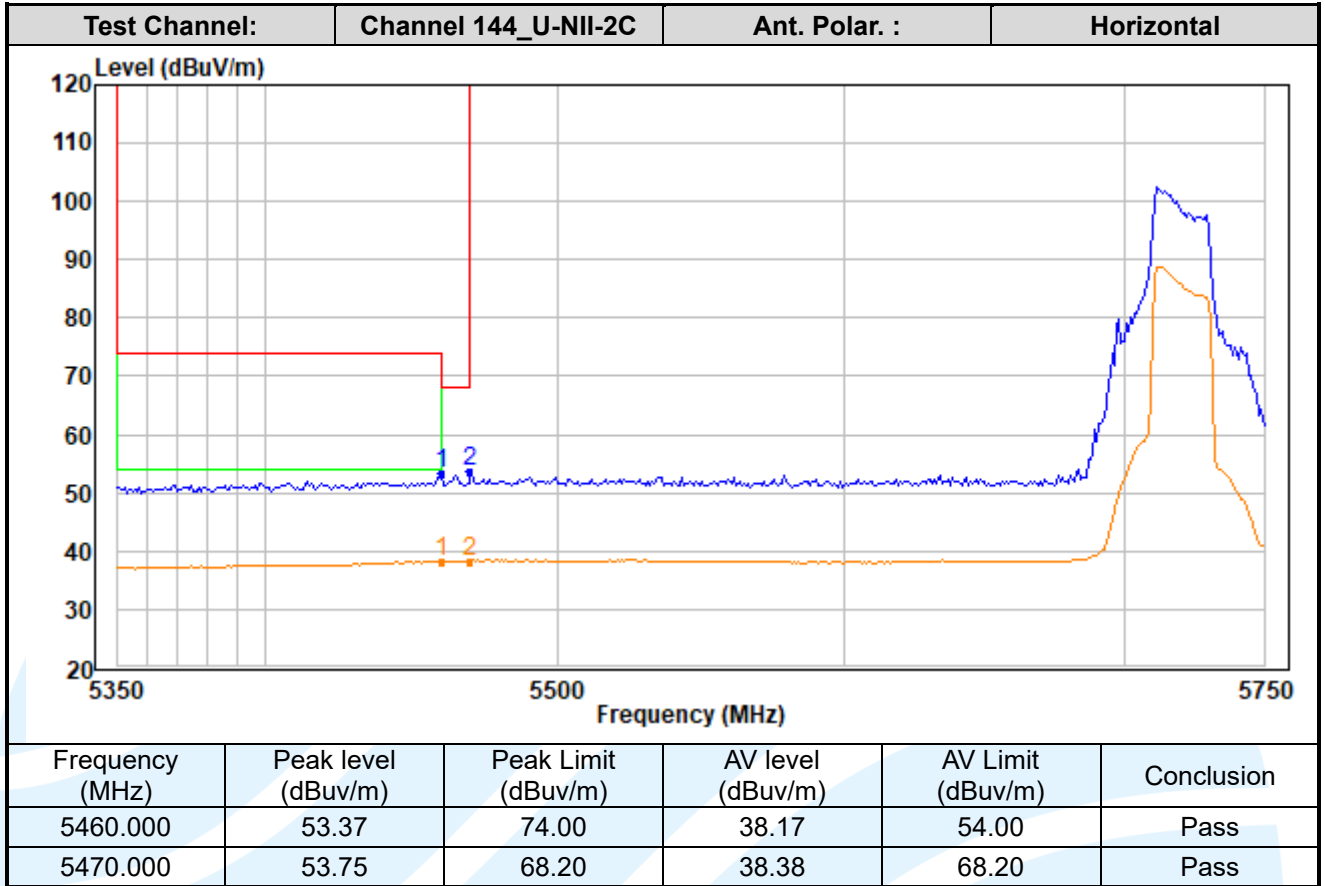

Shenzhen UnionTrust Quality and Technology Co., Ltd.

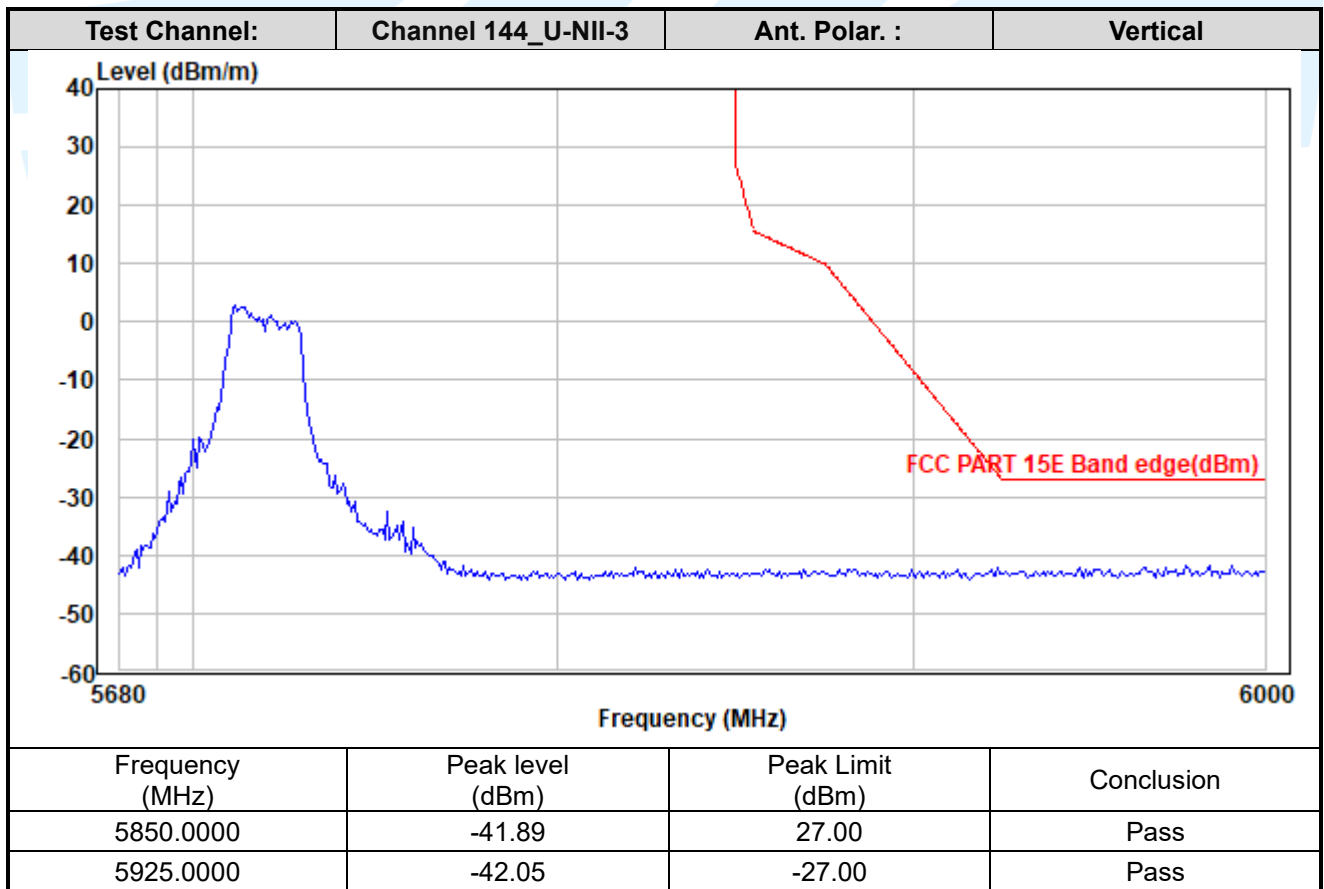
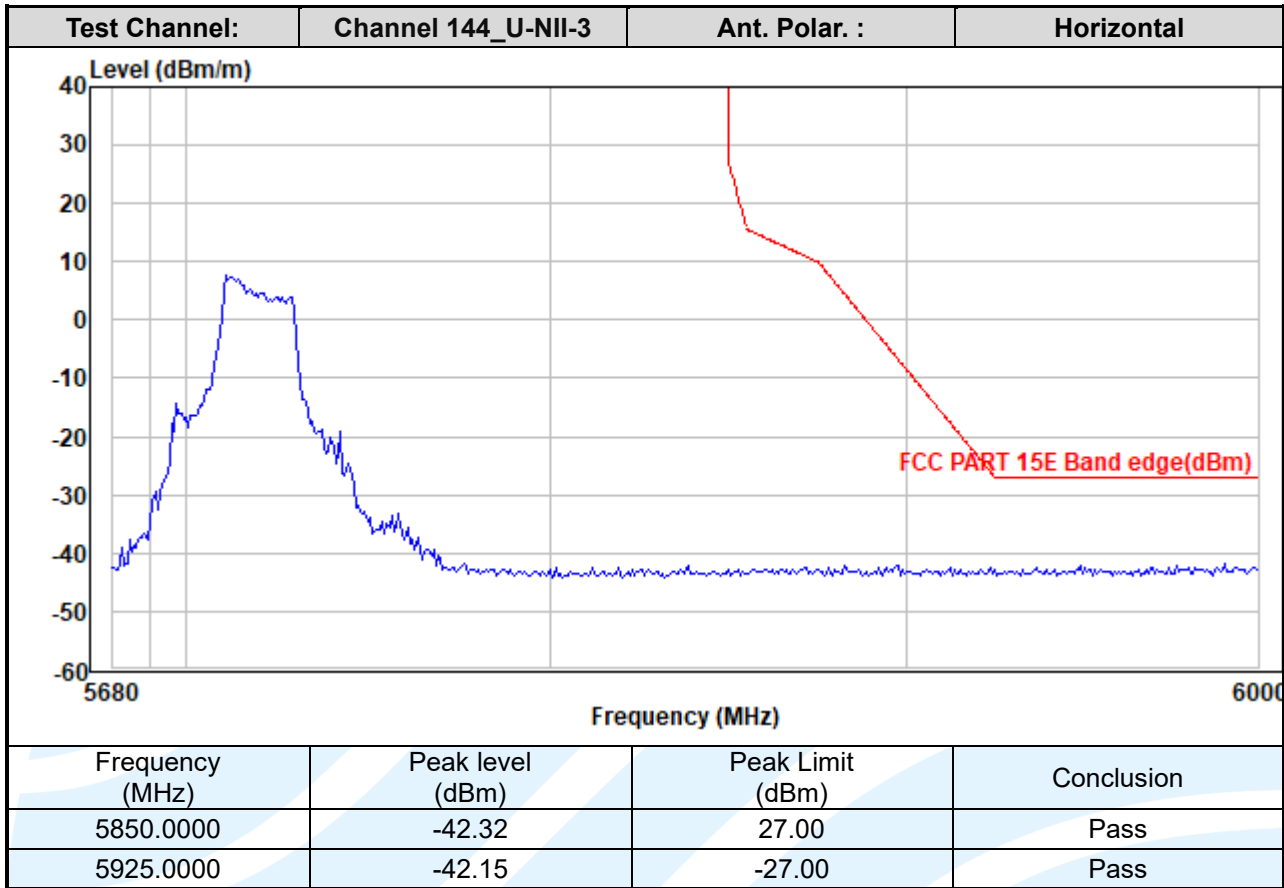

Shenzhen UnionTrust Quality and Technology Co., Ltd.

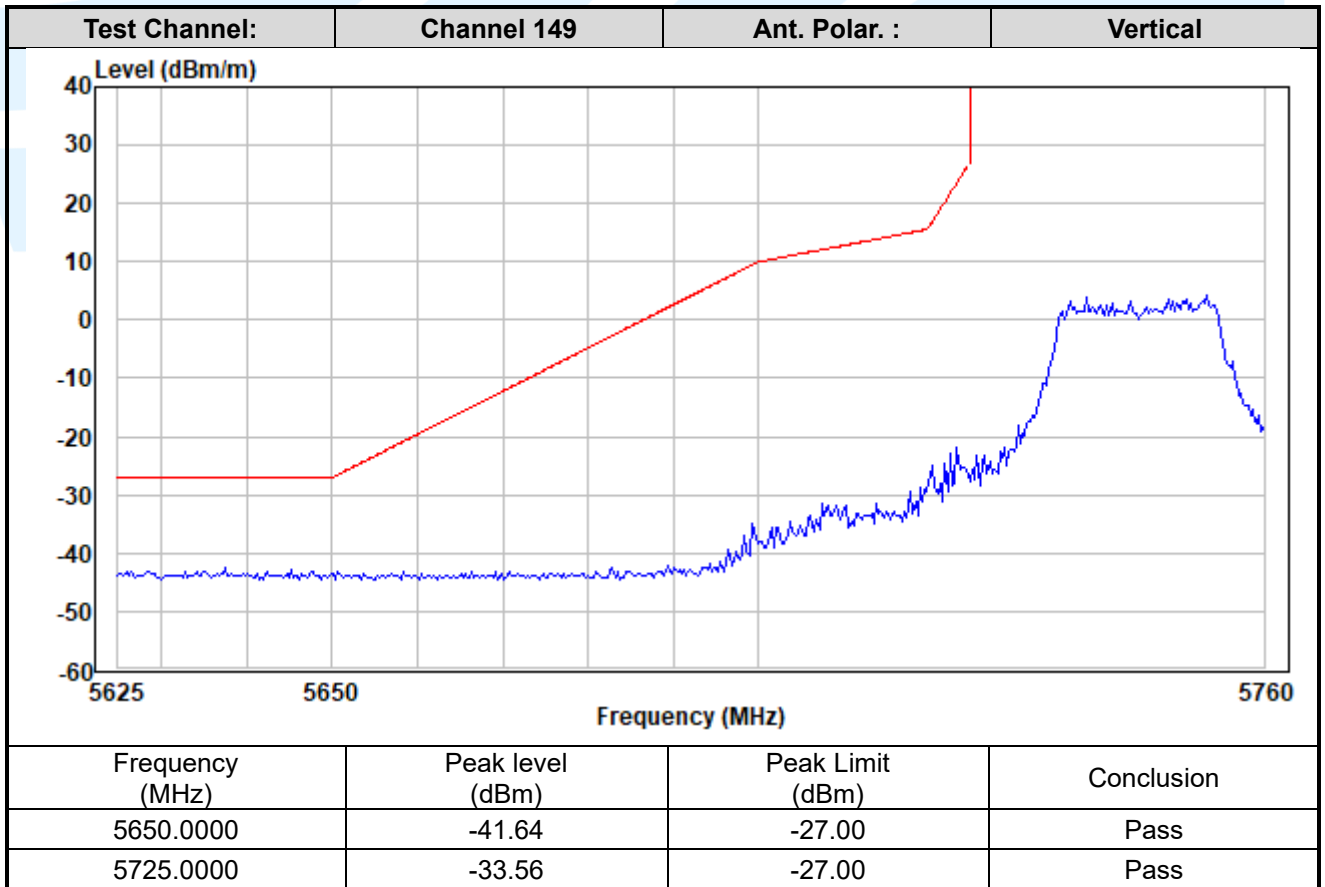
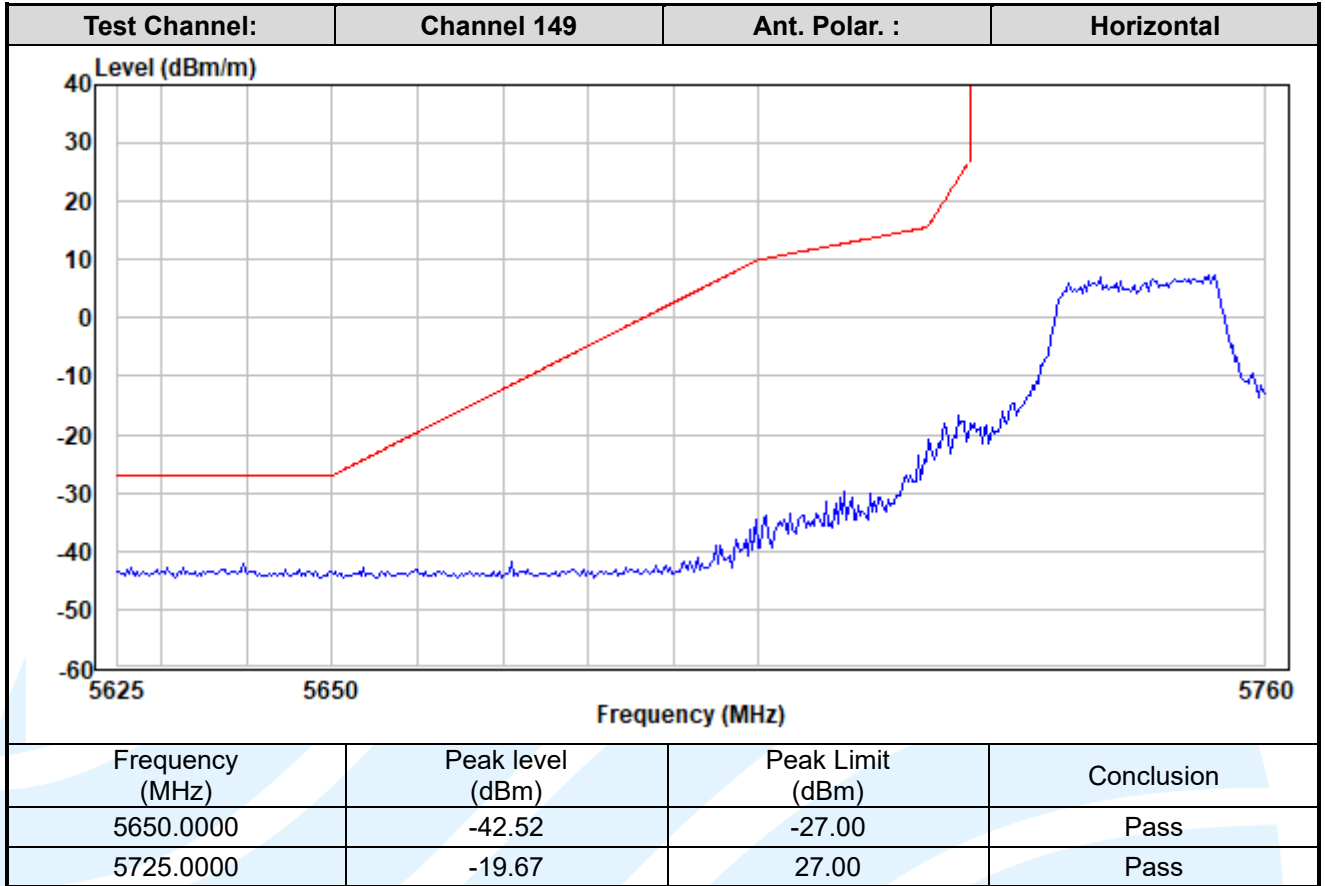

Shenzhen UnionTrust Quality and Technology Co., Ltd.

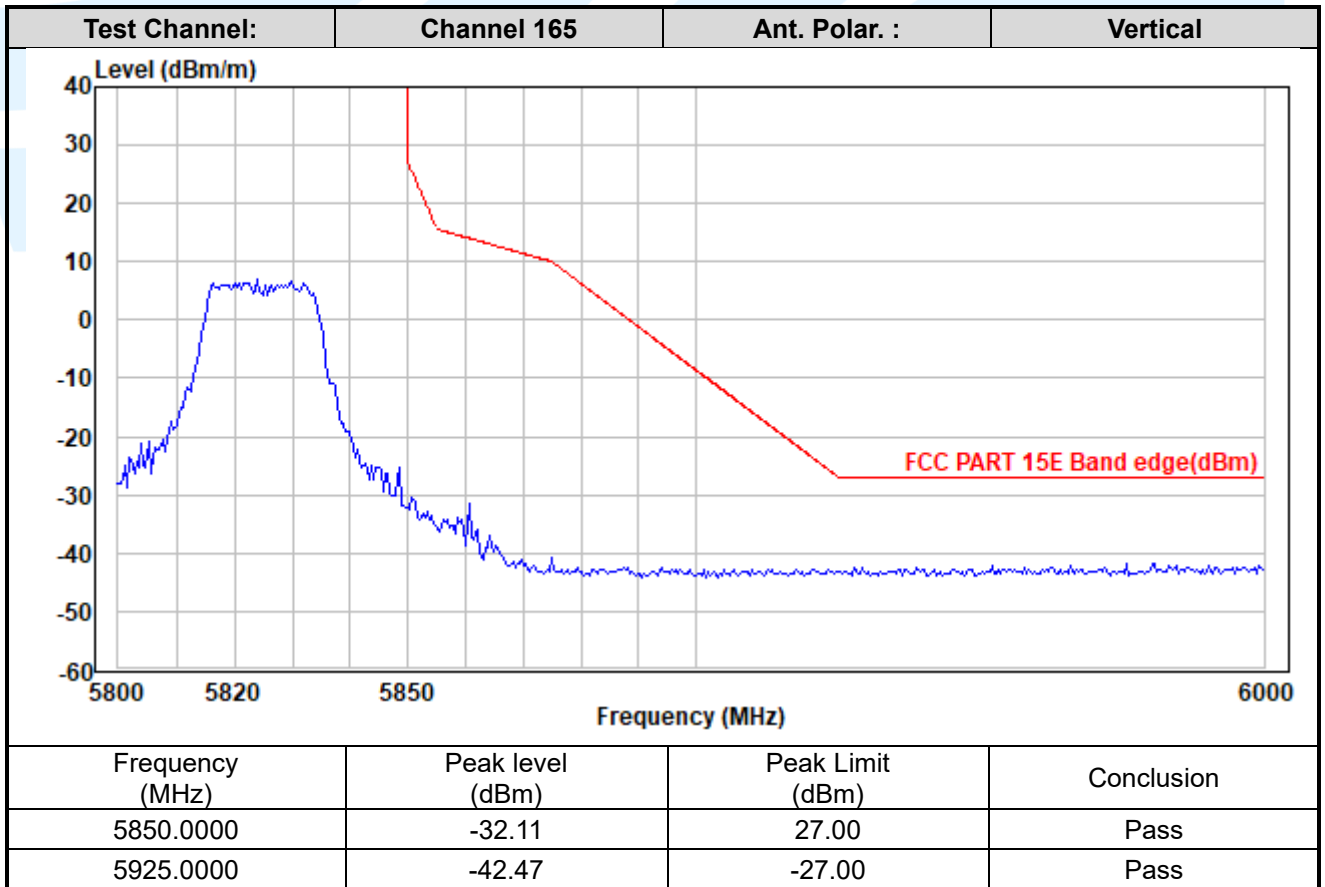
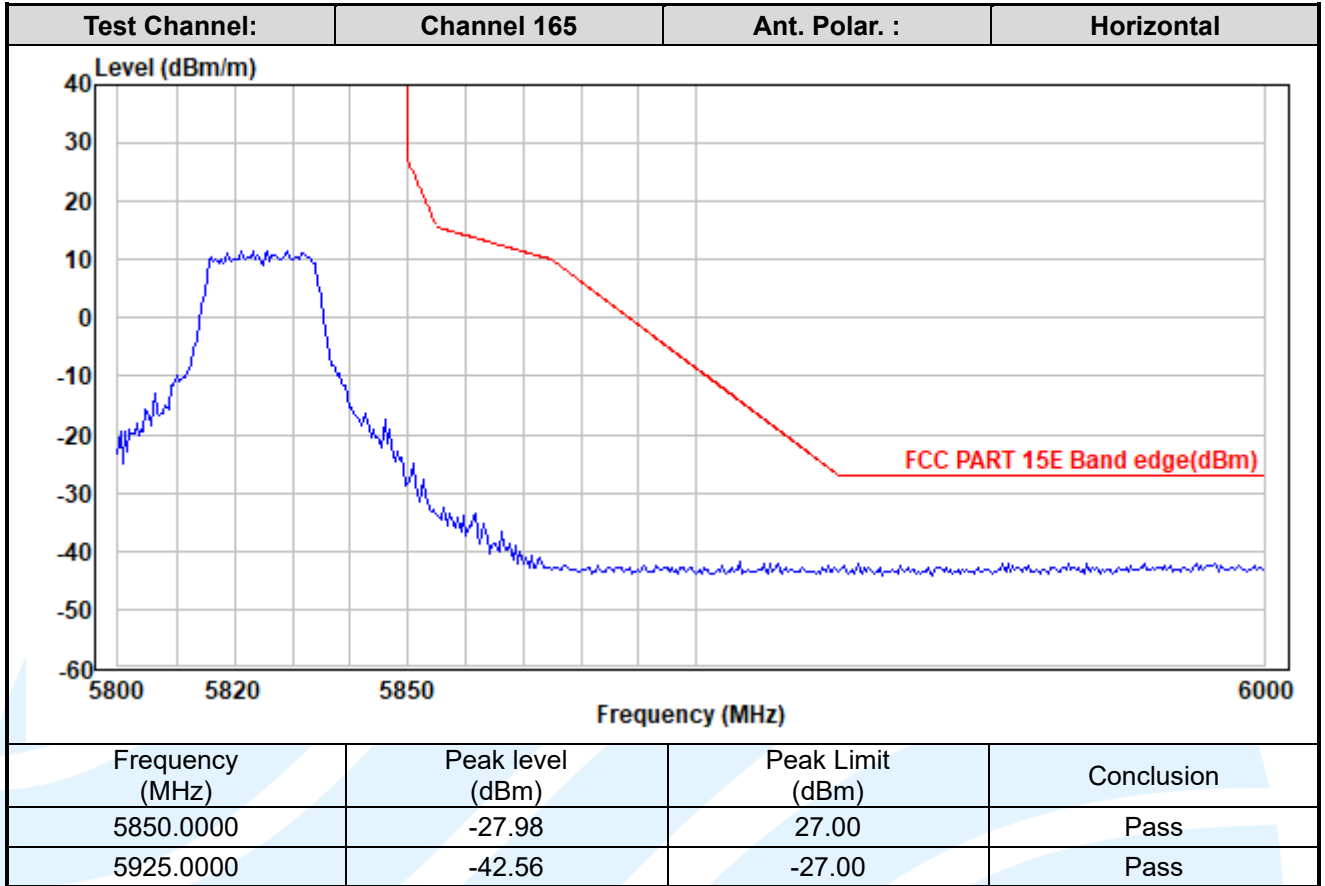

Shenzhen UnionTrust Quality and Technology Co., Ltd.

IEEE 802.11ax-HE40

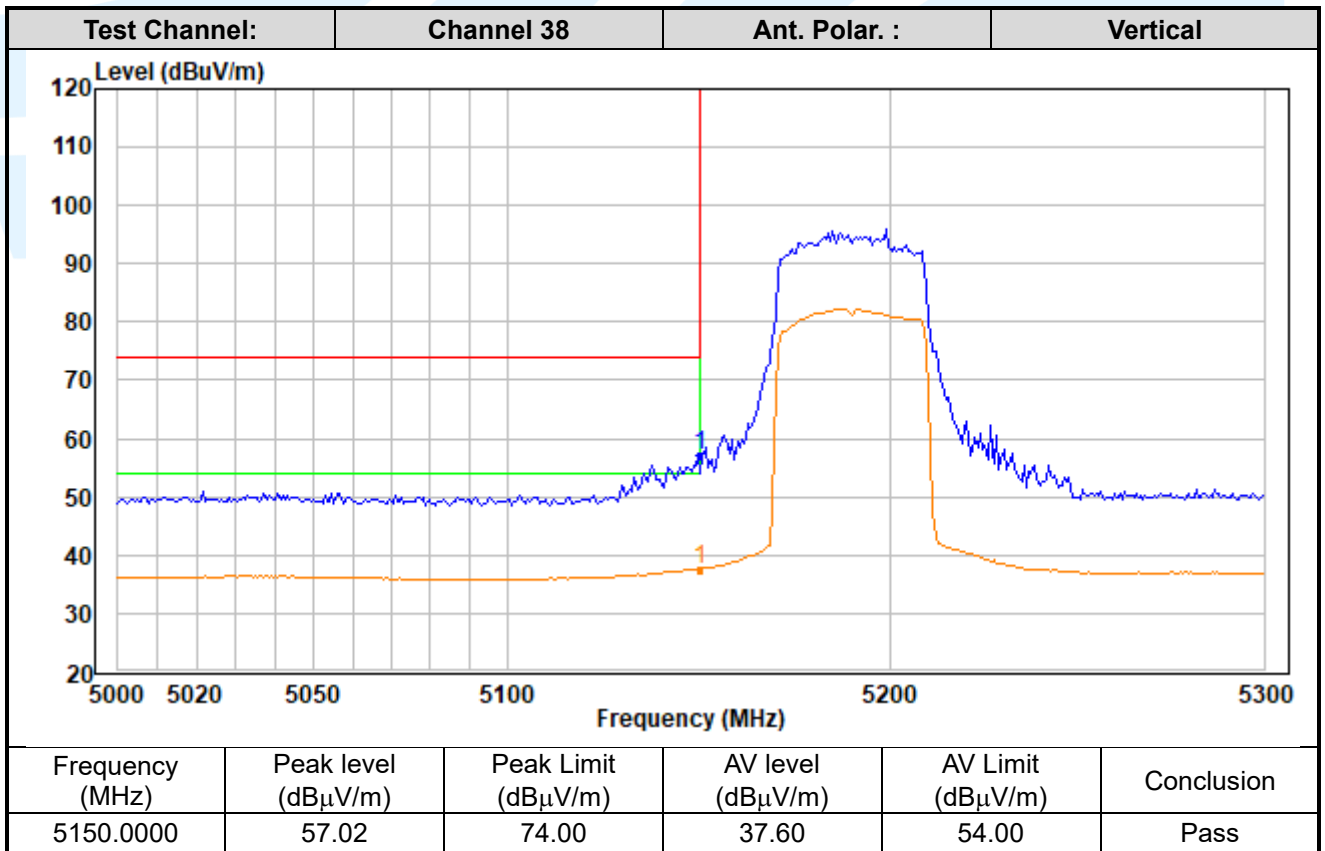
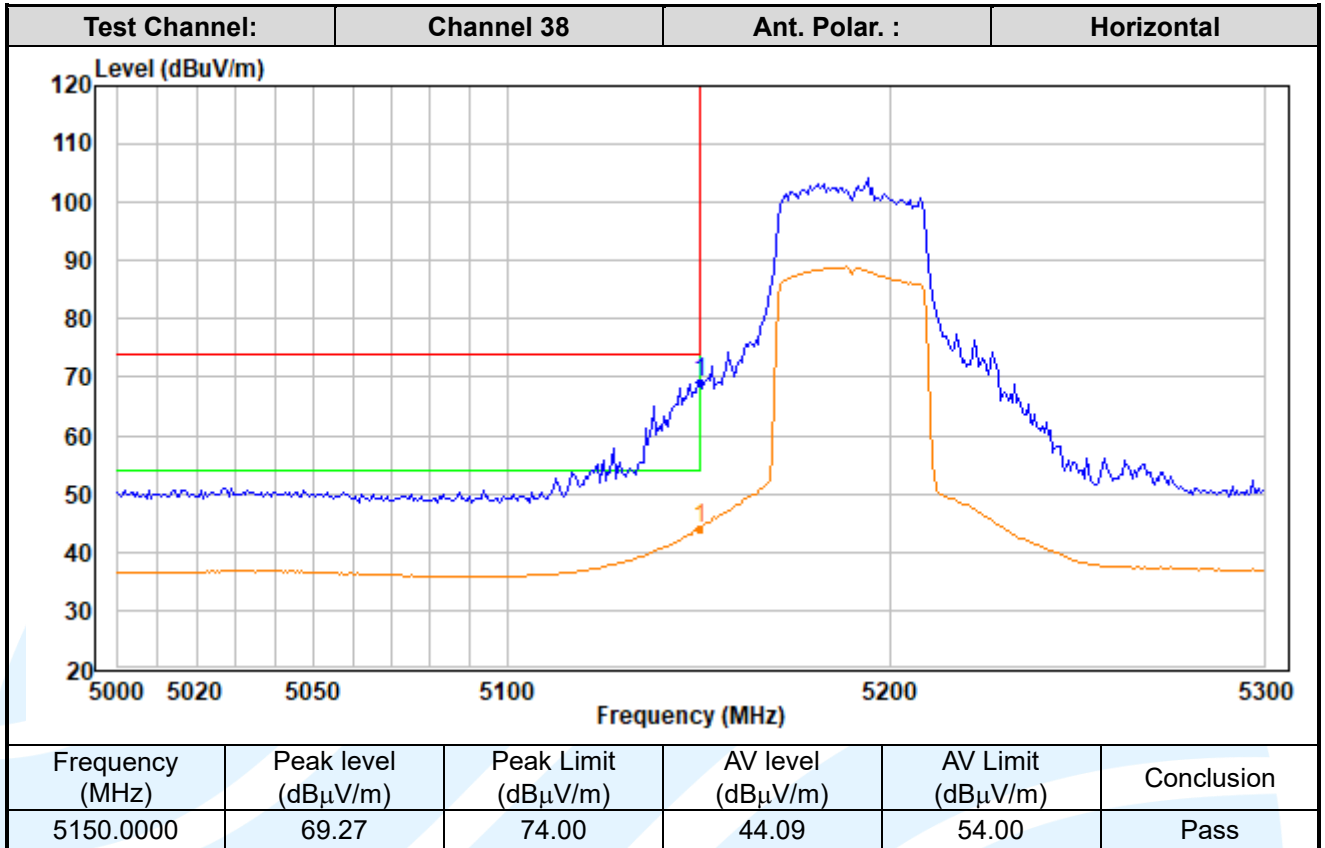

Shenzhen UnionTrust Quality and Technology Co., Ltd.

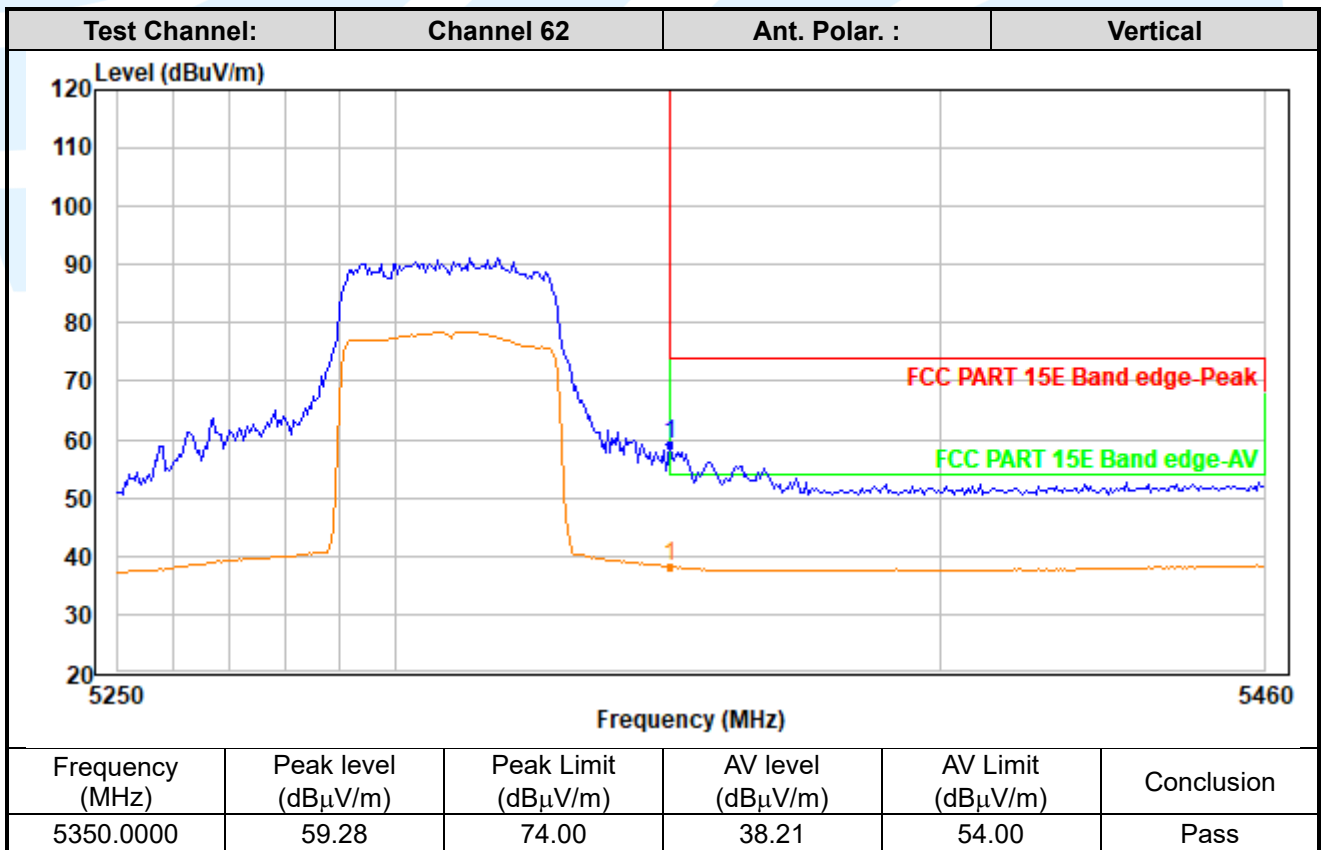
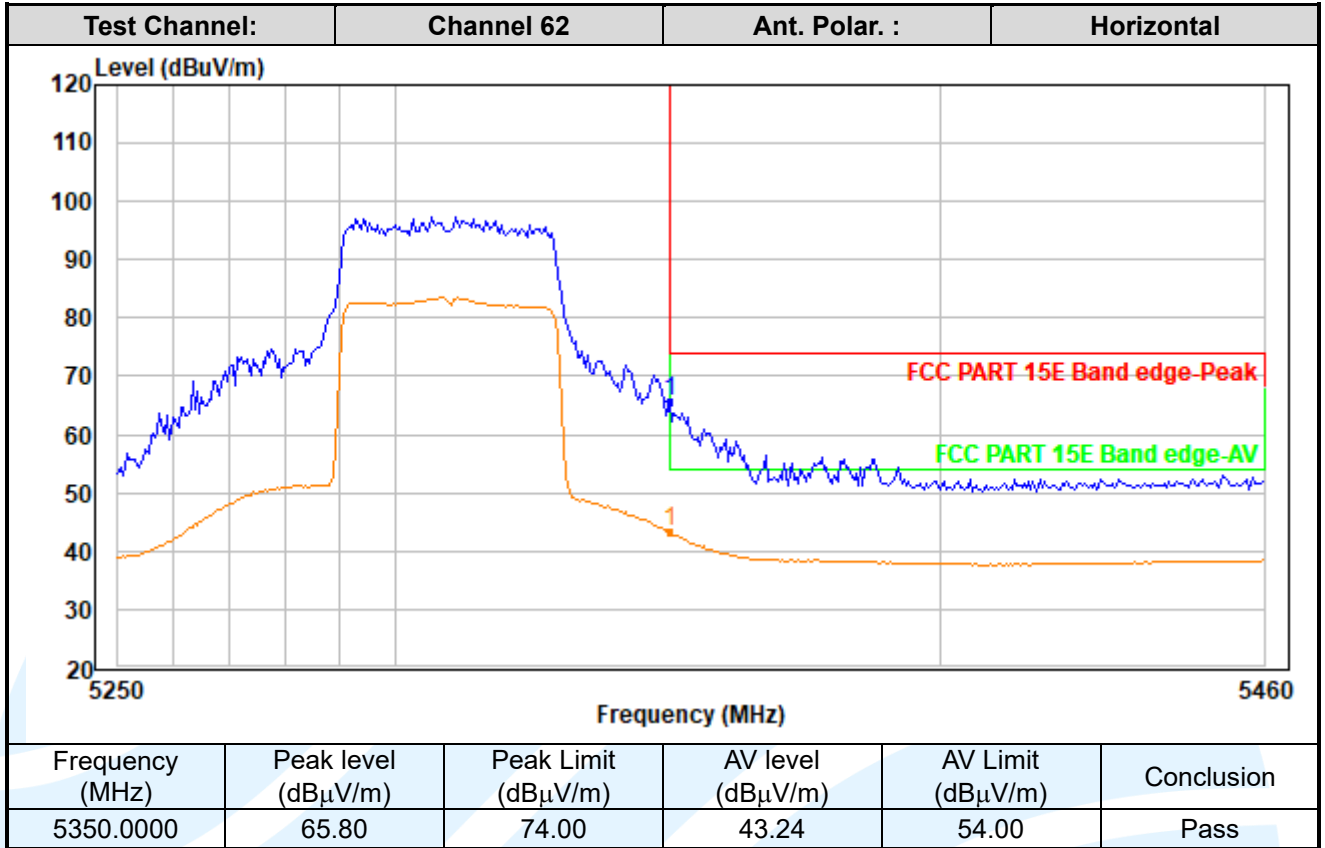

Shenzhen UnionTrust Quality and Technology Co., Ltd.

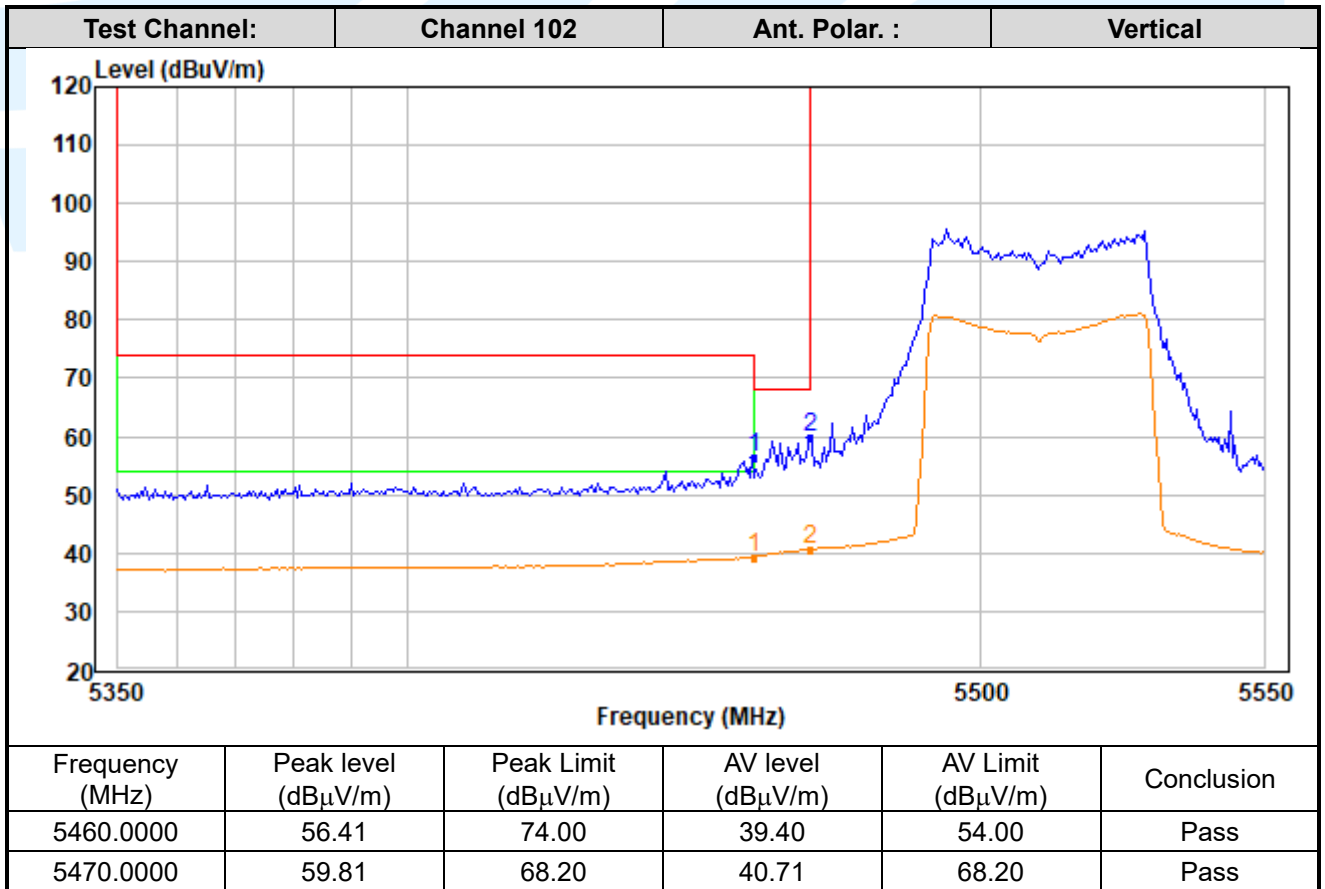
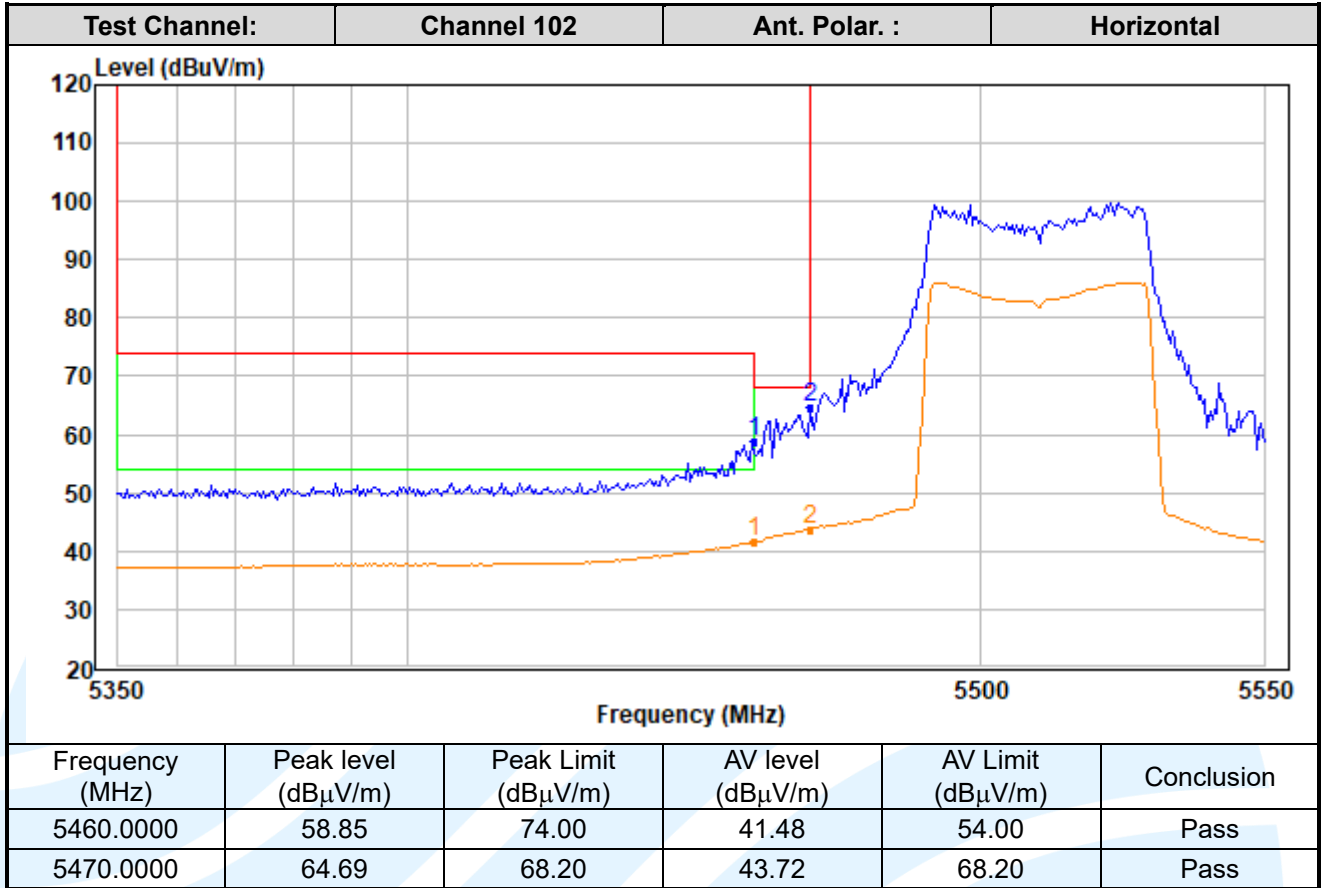

Shenzhen UnionTrust Quality and Technology Co., Ltd.

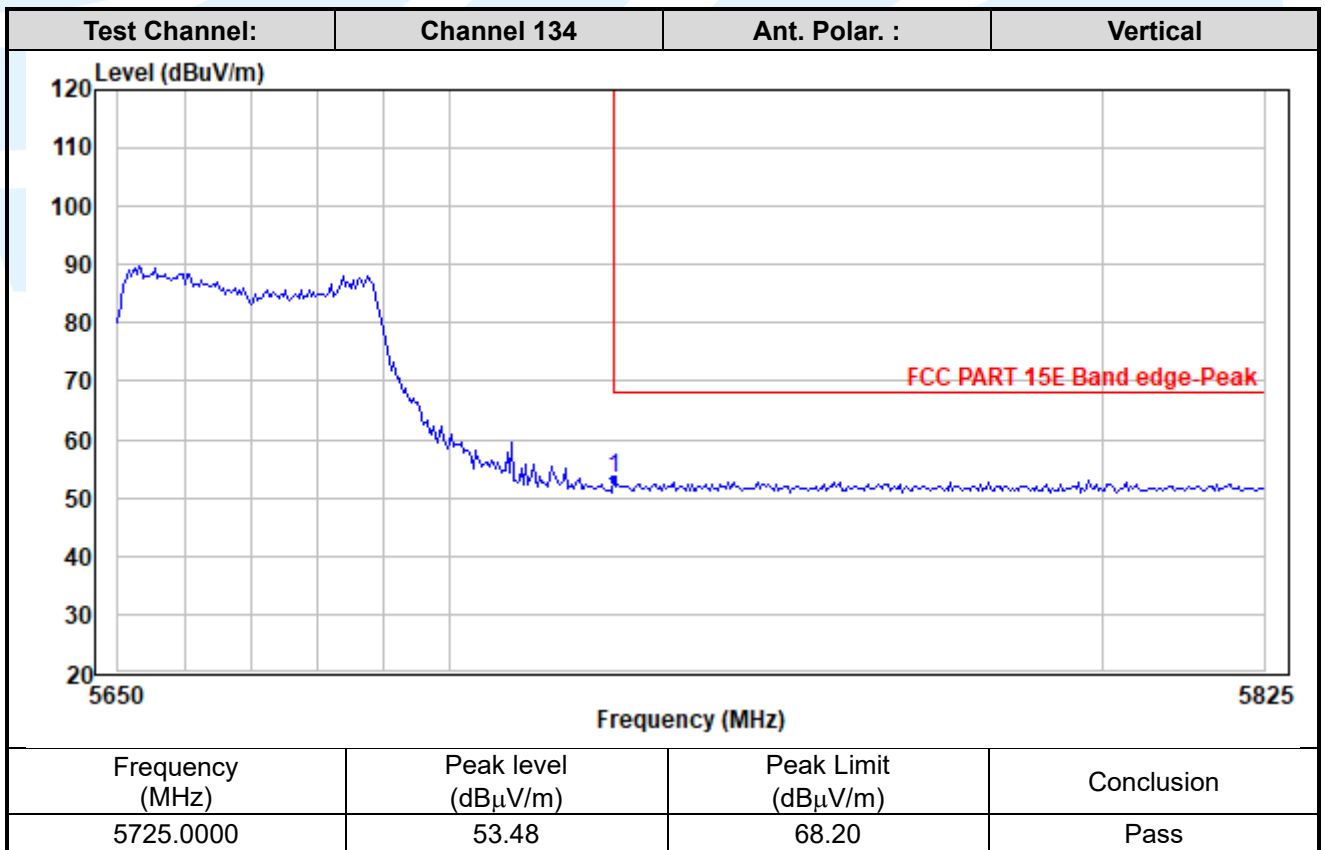
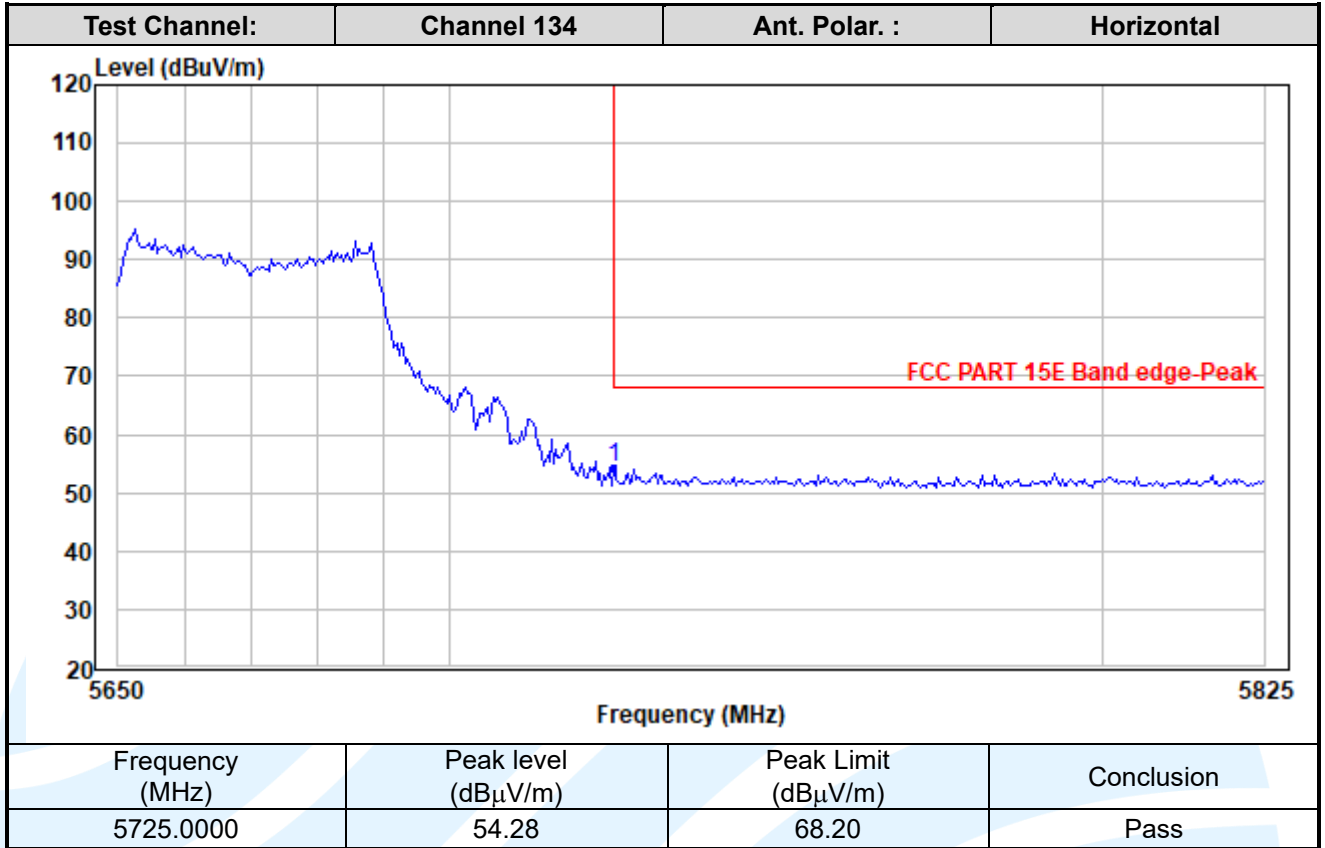

Shenzhen UnionTrust Quality and Technology Co., Ltd.

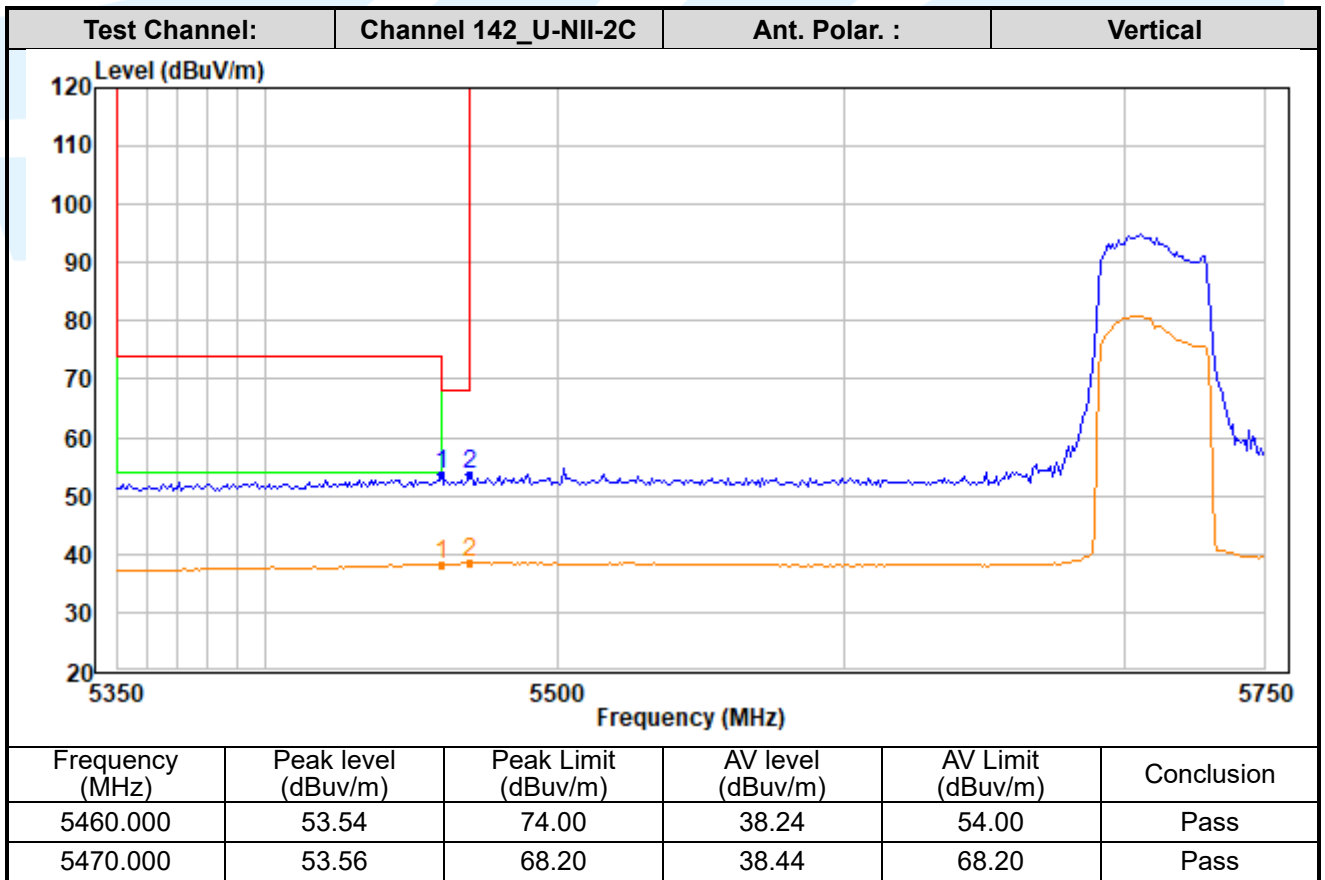
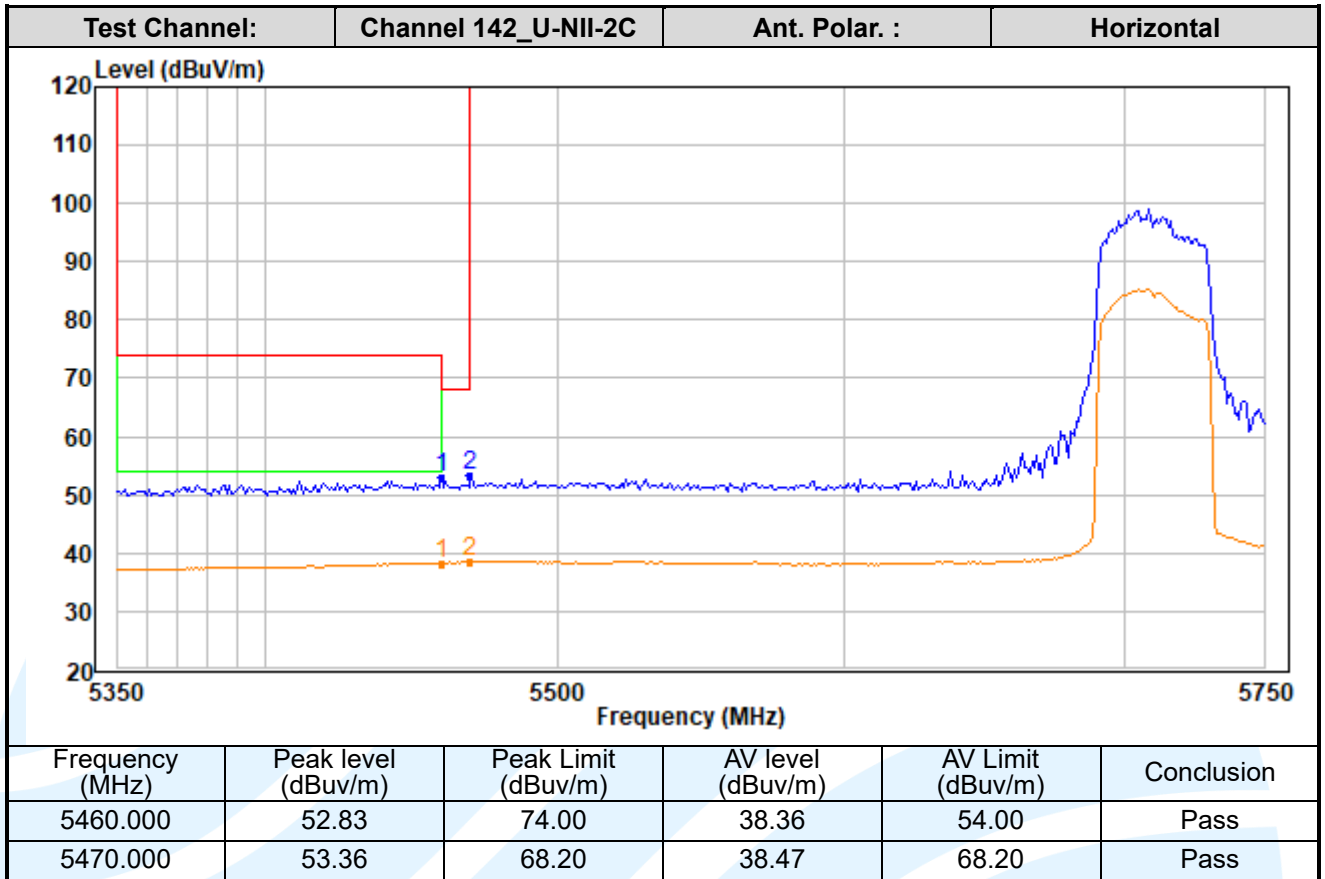

Shenzhen UnionTrust Quality and Technology Co., Ltd.

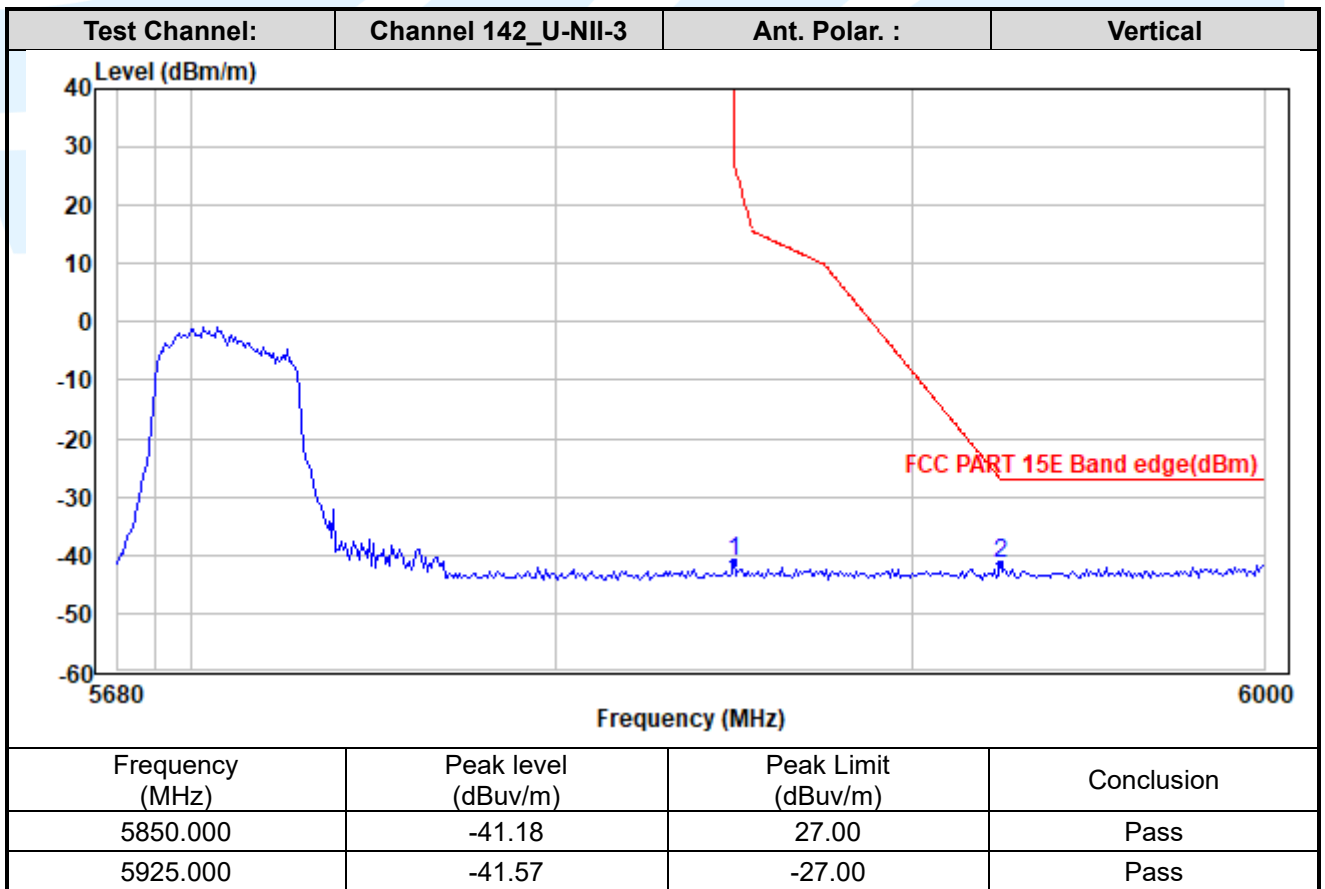
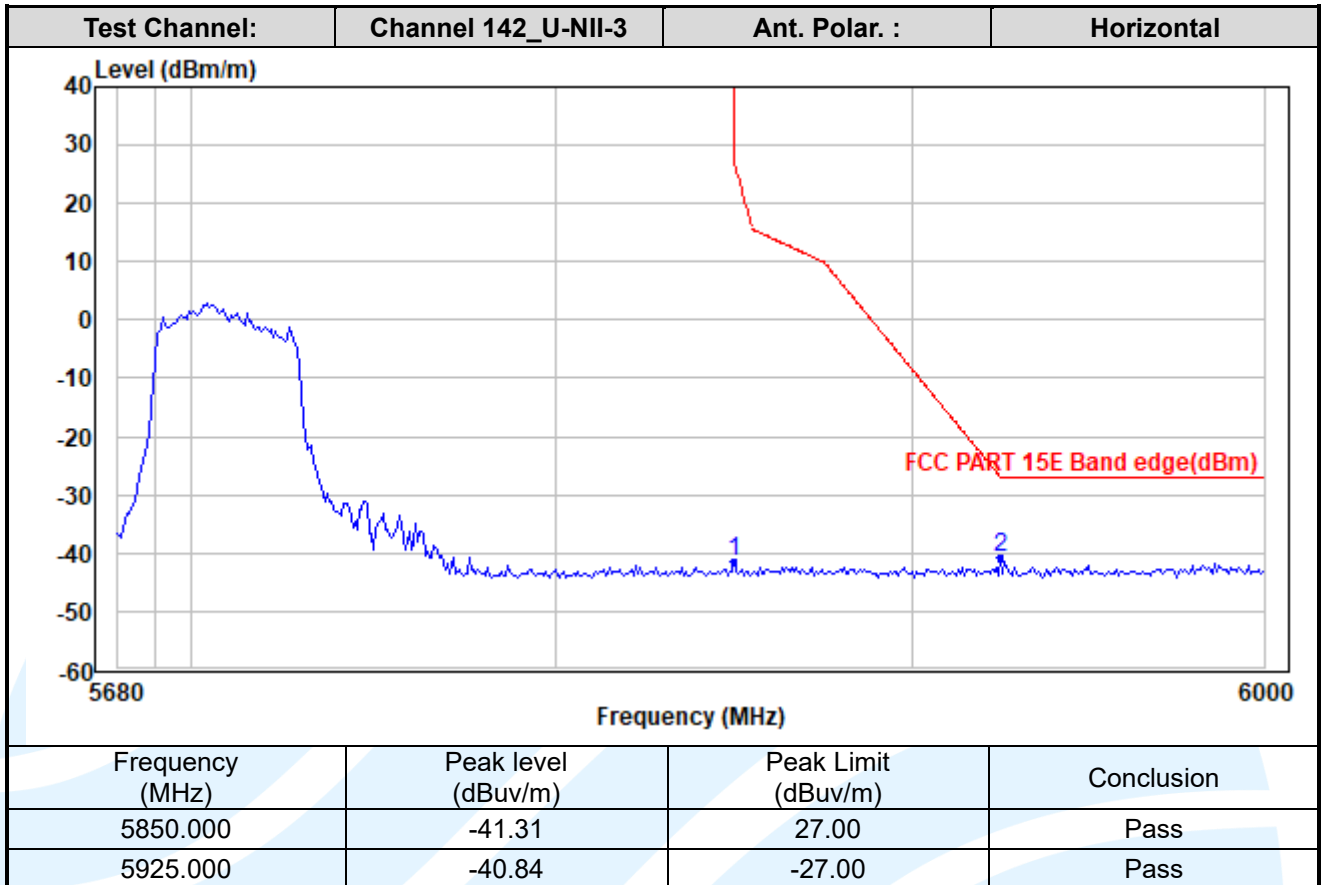

Shenzhen UnionTrust Quality and Technology Co., Ltd.

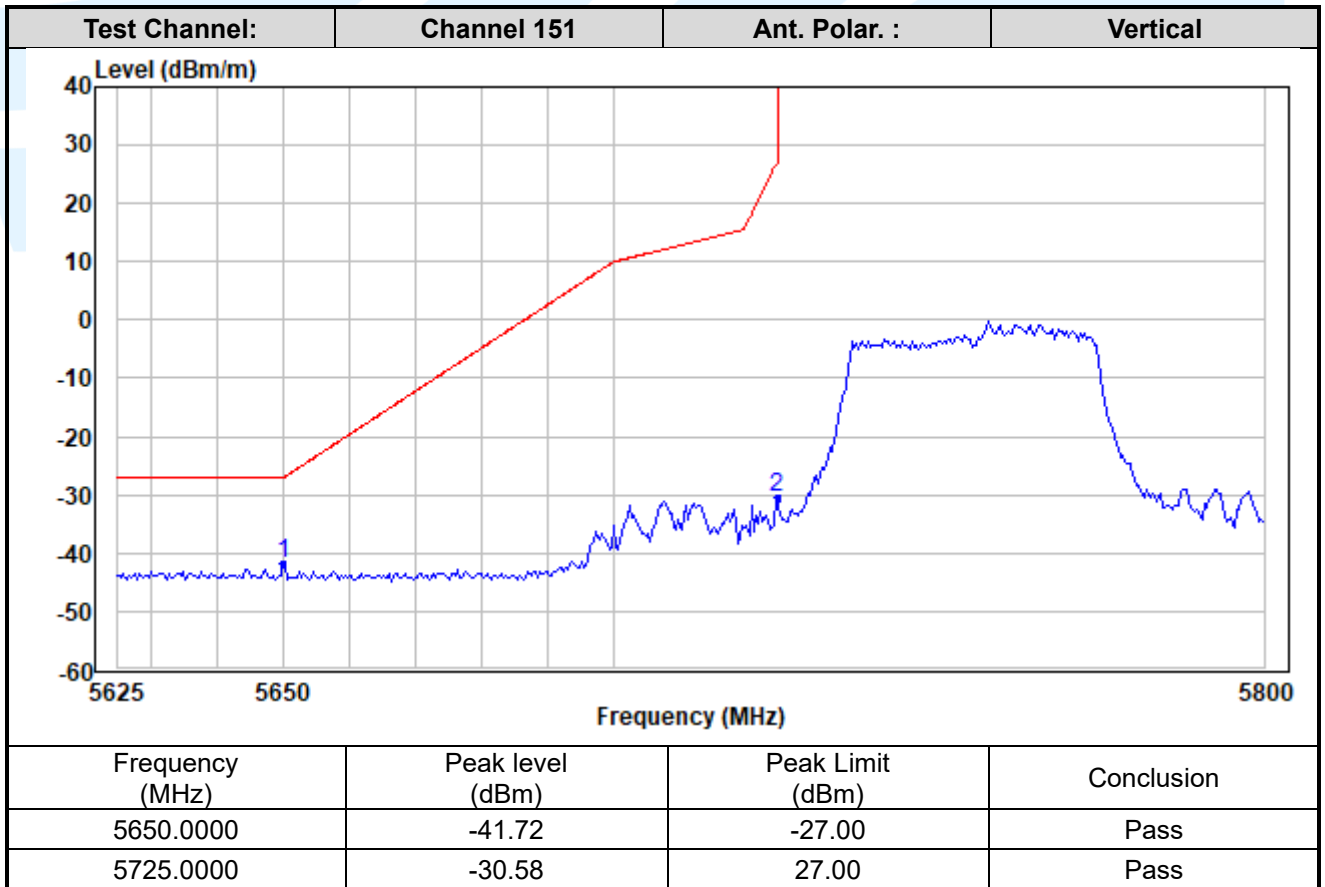
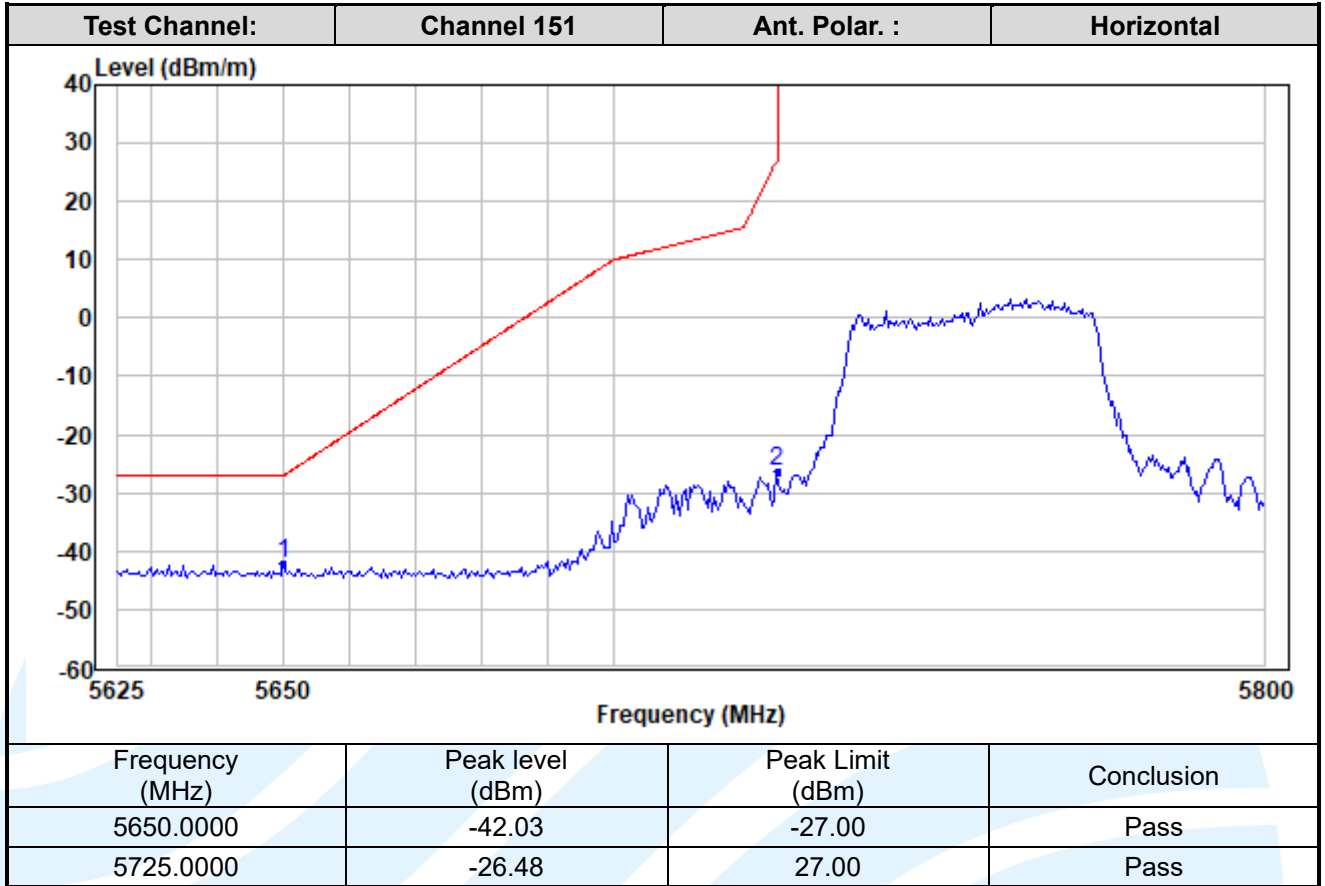

Shenzhen UnionTrust Quality and Technology Co., Ltd.

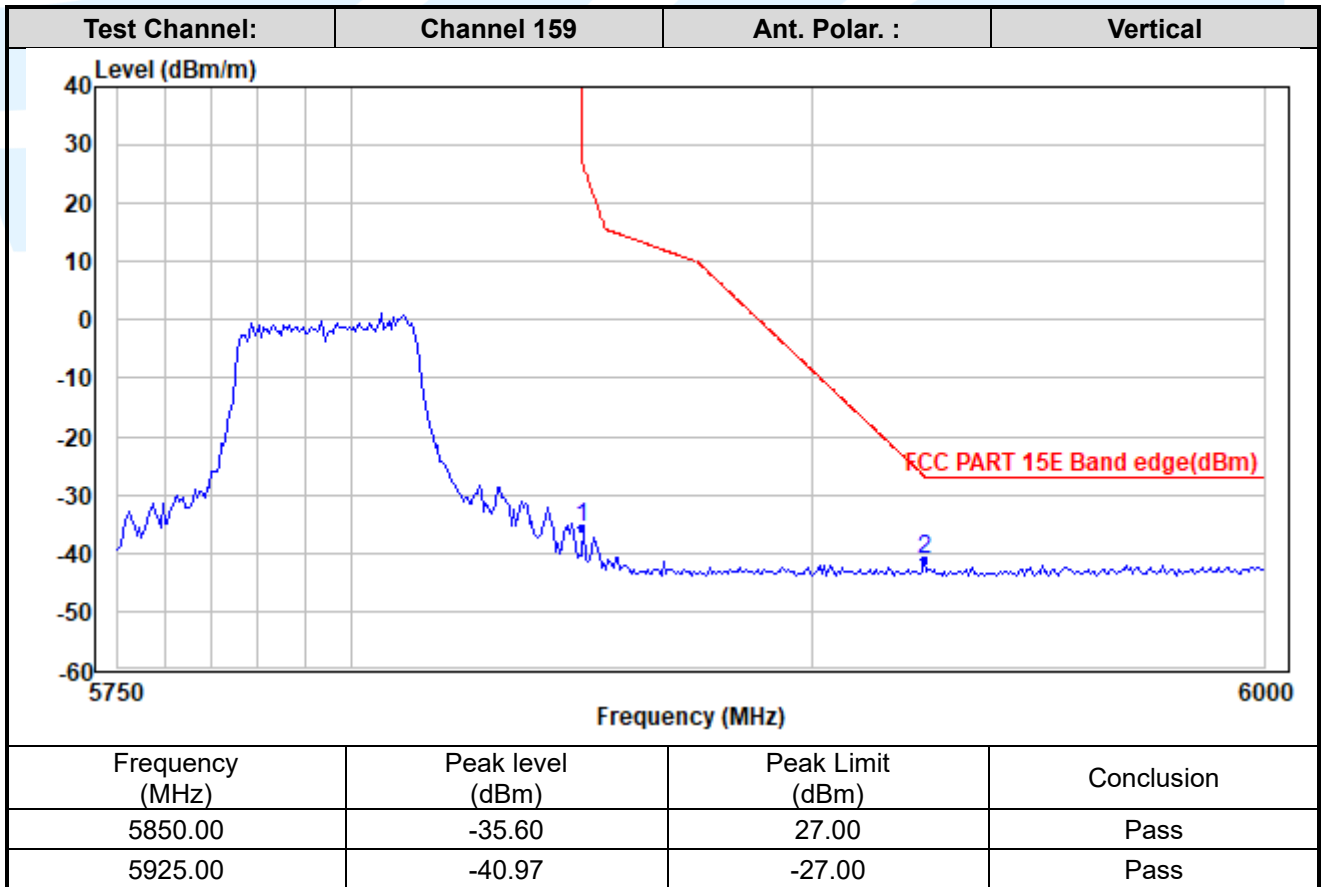
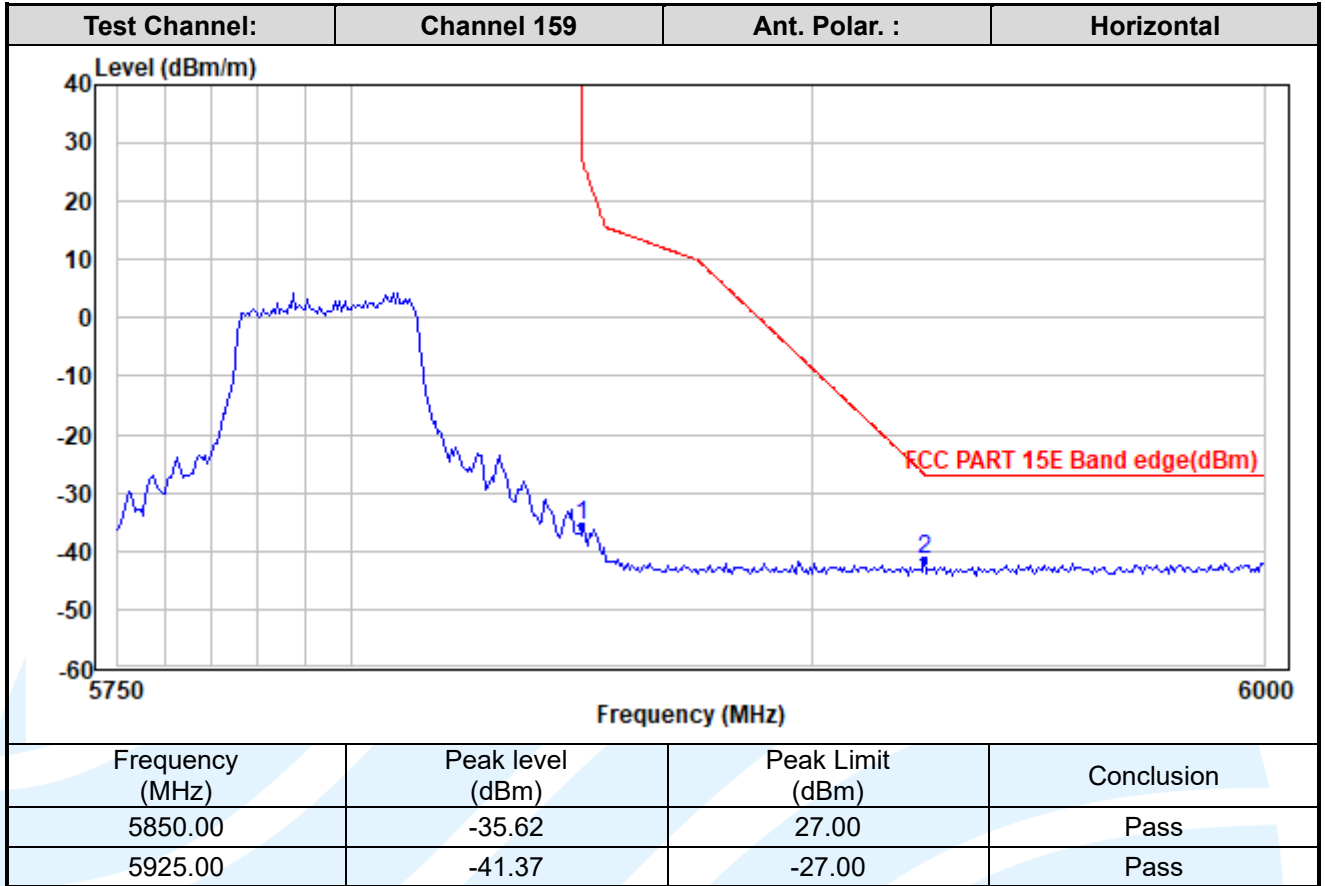

Shenzhen UnionTrust Quality and Technology Co., Ltd.

5.8 DYNAMIC FREQUENCY SELECTION

Test Requirement: FCC 47 CFR Part 15 Subpart E Section 15.407 (h)

Test Method: KDB 905462 D03 Client Without DFS New Rules v01r02

EUT Operating Mode:

DFS Operational mode	Operating Frequency Range	
	5250 MHz to 5350 MHz	5470 MHz to 5725 MHz
Slave without radar Interference detection function	✓	✓

Applicability:

The following table from KDB905462 and the lists of the applicable requirements for the DFS testing.

Applicability of DFS Requirements Prior to Use of a Channel:

Requirement	Operational Mode		
	Master	Client Without Radar Detection	Client With Radar Detection
Non-Occupancy Period	✓	Not required	Yes
DFS Detection Threshold	✓	Not required	Yes
Channel Availability Check Time	✓	Not required	Not required
U-NII Detection Bandwidth	✓	Not required	Yes

Applicability of DFS requirements during normal operation:

Requirement	Operational Mode	
	Master Device or Client with Radar Detection	Client Without Radar Detection
DFS Detection Threshold	Yes	Not required
Channel Closing Transmission Time	Yes	Yes
Channel Move Time	Yes	Yes
U-NII Detection Bandwidth	Yes	Not required
Additional requirements for devices with multiple bandwidth modes	Master Device or Client with Radar Detection	Client Without Radar Detection
U-NII Detection Bandwidth and Statistical Performance Check	All BW modes must be tested	Not required
Channel Move Time and Channel Closing Transmission Time	Test using widest BW mode available	Test using the widest BW mode available for the link
All other tests	Any single BW mode	Not required

Note: Frequencies selected for statistical performance check (Section 7.8.4) should include several frequencies within the radar detection bandwidth and frequencies near the edge of the radar detection bandwidth. For 802.11 devices it is suggested to select frequencies in each of the bonded 20 MHz channels and the channel center frequency.

DFS Detection Thresholds for Master Devices and Client Devices with Radar Detection:

Maximum Transmit Power	Value (See Notes 1, 2, and 3)
EIRP ≥ 200 milliwatt	-64 dBm
EIRP < 200 milliwatt and power spectral density < 10 dBm/MHz	-62 dBm
EIRP < 200 milliwatt that do not meet the power spectral density requirement	-64dBm

Note 1: This is the level at the input of the receiver assuming a 0 dBi receive antenna.

Note 2: Throughout these test procedures an additional 1 dB has been added to the amplitude of the test transmission waveforms to account for variations in measurement equipment. This will ensure that the test signal is at or above the detection threshold level to trigger a DFS response.

Note 3: EIRP is based on the highest antenna gain. For MIMO devices refer to KDB Publication 662911 D01.

DFS Radar Signal Parameter Values:

Parameter	Value
Non-occupancy period	Minimum 30 minutes
Channel Availability Check Time	60 seconds
Channel Move Time	10 seconds (See Note 1.)
Channel Closing Transmission Time	200 milliseconds + an aggregate of 60 milliseconds over remaining 10 second period. (See Notes 1 and 2.)
U-NII Detection Bandwidth	Minimum 100% of the U-NII 99% transmission power bandwidth. (See Note 3.)

Note 1: Channel Move Time and the Channel Closing Transmission Time should be performed with Radar Type 0. The measurement timing begins at the end of the Radar Type 0 burst.

Note 2: The Channel Closing Transmission Time is comprised of 200 milliseconds starting at the beginning of the Channel Move Time plus any additional intermittent control signals required to facilitate a Channel move (an aggregate of 60 milliseconds) during the remainder of the 10 second period. The aggregate duration of control signals will not count quiet periods in between transmissions.

Note 3: During the U-NII Detection Bandwidth detection test, radar type 0 should be used. For each frequency step the minimum percentage of detection is 90 percent. Measurements are performed with no data traffic.

DFS Radar Signal Parameter:

Radar Type 0 was used in the evaluation of the Client device for the purpose of measuring the Channel Move Time and the Channel Closing Transmission Time

Table 1-Short Pulse Radar Test Waveforms

Radar Type	Pulse Width (µsec)	PRI (µsec)	Number of Pulses	Minimum Percentage of Successful Detection	Minimum Trials
0	1	1428	18	See Note 1.	See Note 1.
1	1	Test A Test B	Roundup $\left\{ \begin{matrix} \left(\frac{1}{360} \right) \\ \left(\frac{19 \cdot 10^6}{PRI_{\mu sec}} \right) \end{matrix} \right\}$	60%	30
2	1-5	150-230	23-29	60%	30
3	6-10	200-500	16-18	60%	30
4	11-20	200-500	12-16	60%	30
Aggregate (Radar Types 1-4)				80%	120

Note 1: Short Pulse Radar Type 0 should be used for the detection bandwidth test, channel move time, and channel closing time tests.

Test A: 15 unique PRI values randomly selected from the list of 23 PRI values in Table 5a
 Test B: 15 unique PRI values randomly selected within the range of 518-3066 µsec, with a minimum increment of 1 µsec, excluding PRI values selected in Test A
 A minimum of 30 unique waveforms are required for each of the Short Pulse Radar Types 2 through 4. If more than 30 waveforms are used for Short Pulse Radar Types 2 through 4, then each additional waveform must also be unique and not repeated from the previous waveforms.
 If more than 30 waveforms are used for Short Pulse Radar Type 1, then each additional waveform is generated with Test B and must also be unique and not repeated from the previous waveforms in Tests A or B.

The aggregate is the average of the percentage of successful detections of short pulse radar types 1-4

Table 2-Long Pulse Radar Test Waveform

Radar Type	Pulse Width (μsec)	Chirp Width (MHz)	PRI (μsec)	Number of Pulses per Burst	Number of Bursts	Minimum Percentage of Successful Detection	Minimum Trials
5	50-100	5-20	1000-2000	1-3	8-20	80%	30

Table 3-Frequency Hopping Radar Test Waveform

Radar Type	Pulse Width (μsec)	PRI (μsec)	Pulses per Hop	Hopping Rate (kHz)	Hopping Sequence Length (msec)	Minimum Percentage of Successful Detection	Minimum Trials
6	1	333	9	0.333	300	70%	30

In-Service Monitoring: Channel Move Time, Channel Closing Transmission Time and Non-Occupancy Period

Limit of In-Service Monitoring:

Reference to DFS Radar Signal Parameter Values.

Test Procedures:

- One frequency will be chosen from the Operating Channels of the EUT within the 5250-5350 MHz or 5470-5725 MHz bands. For 802.11 devices, the test frequency must contain control signals. This can be verified by disabling channel loading and monitoring the spectrum analyzer. If no control signals are detected, another frequency must be selected within the emission bandwidth where control signals are detected.
- In case the EUT is a Master Device, a U-NII device operating as a Client Device will be used and it is assumed that the Client will associate with the EUT (Master). For radiated tests, the emissions of the Radar Waveform generator will be directed towards the Master Device. If the Master Device has antenna gain, the main beam of the antenna will be directed toward the radar emitter. Vertical polarization is used for testing.
- The TCP protocol unicast data stream was generated by the iperf software command line with at least 17% activity ratio over any 100ms period.
- Timing plots are reported with calculations demonstrating a minimum channel loading of approximately 17% or greater. For example, channel loading can be estimated by setting the spectrum analyzer for zero span and approximate the Time On/ (Time On + Off Time).
- At time T₀ the Radar Waveform generator sends a Burst of pulses for one of the Short Pulse Radar Types 1-4 at DFS Detection Threshold levels on the Operating Channel. An additional 1 dB is added to the radar test signal to ensure it is at or above the DFS Detection Threshold, accounting for equipment variations/errors.
- Observe the transmissions of the EUT at the end of the radar Burst on the Operating Channel for duration greater than 10 seconds. Measure and record the transmissions from the EUT during the observation time (Channel Move Time). Measure and record the Channel Move Time and Channel Closing Transmission Time if radar detection occurs.
- When operating as a Master Device, monitor the EUT for more than 30 minutes following instant T₂ to verify that the EUT does not resume any transmissions on this Channel. Perform this test once and record the measurement result.

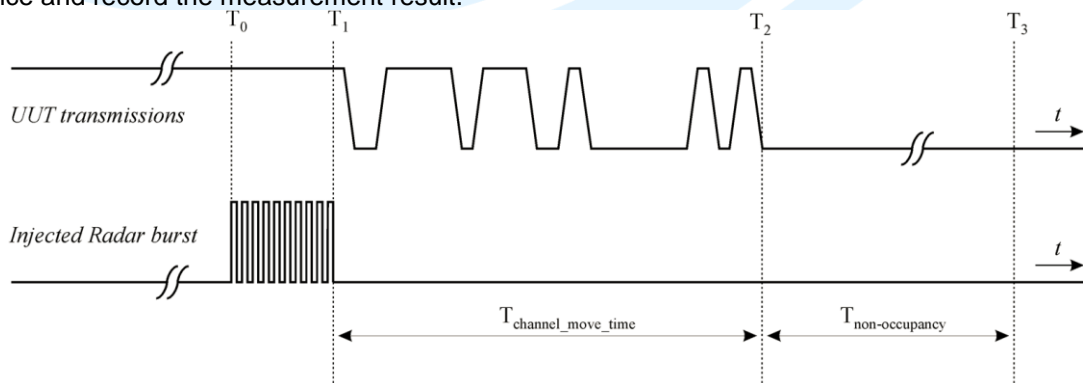
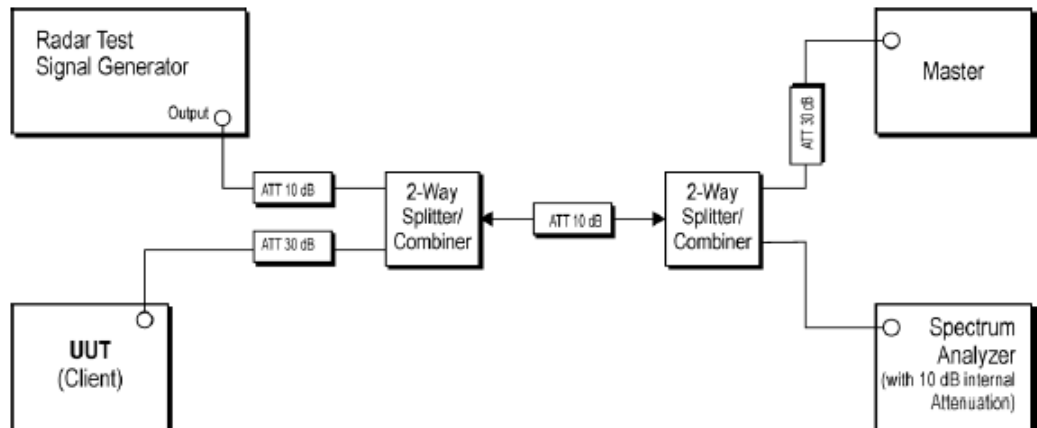

Figure 17: Channel Closing Transmission Time, Channel Move Time and Non-Occupancy Period

Conducted test setup



Setup for Client with injection at the Master

Equipment Used: Refer to section 3 for details.

Test Result: Result of Channel Move Time, Channel Closing Transmission Time and Non-Occupancy Period for Client Beacon Tes

The measurement data as follows:

BW / Channel	Test Item	Test Result	Limit	Pass/Fail
20 MHz / 5300 MHz	Channel Move Time	0.9746 s	< 10s	Pass
	Channel Closing Transmission Time	7.5 ms	< 200+60ms	Pass
	Non-Occupancy Period	No transmission	30 minutes	Pass
20 MHz / 5500 MHz	Channel Move Time	1.0078 s	< 10s	Pass
	Channel Closing Transmission Time	11.1 ms	< 200+60ms	Pass
	Non-Occupancy Period	No transmission	30 minutes	Pass
40MHz / 5310 MHz	Channel Move Time	0.9676 s	< 10s	Pass
	Channel Closing Transmission Time	31.5 ms	< 200+60ms	Pass
	Non-Occupancy Period	No transmission	30 minutes	Pass
40MHz / 5510 MHz	Channel Move Time	1.3306 s	< 10s	Pass
	Channel Closing Transmission Time	21.6 ms	< 200+60ms	Pass
	Non-Occupancy Period	No transmission	30 minutes	Pass

Radar Waveform calibration Plot
Reference DFS test signal

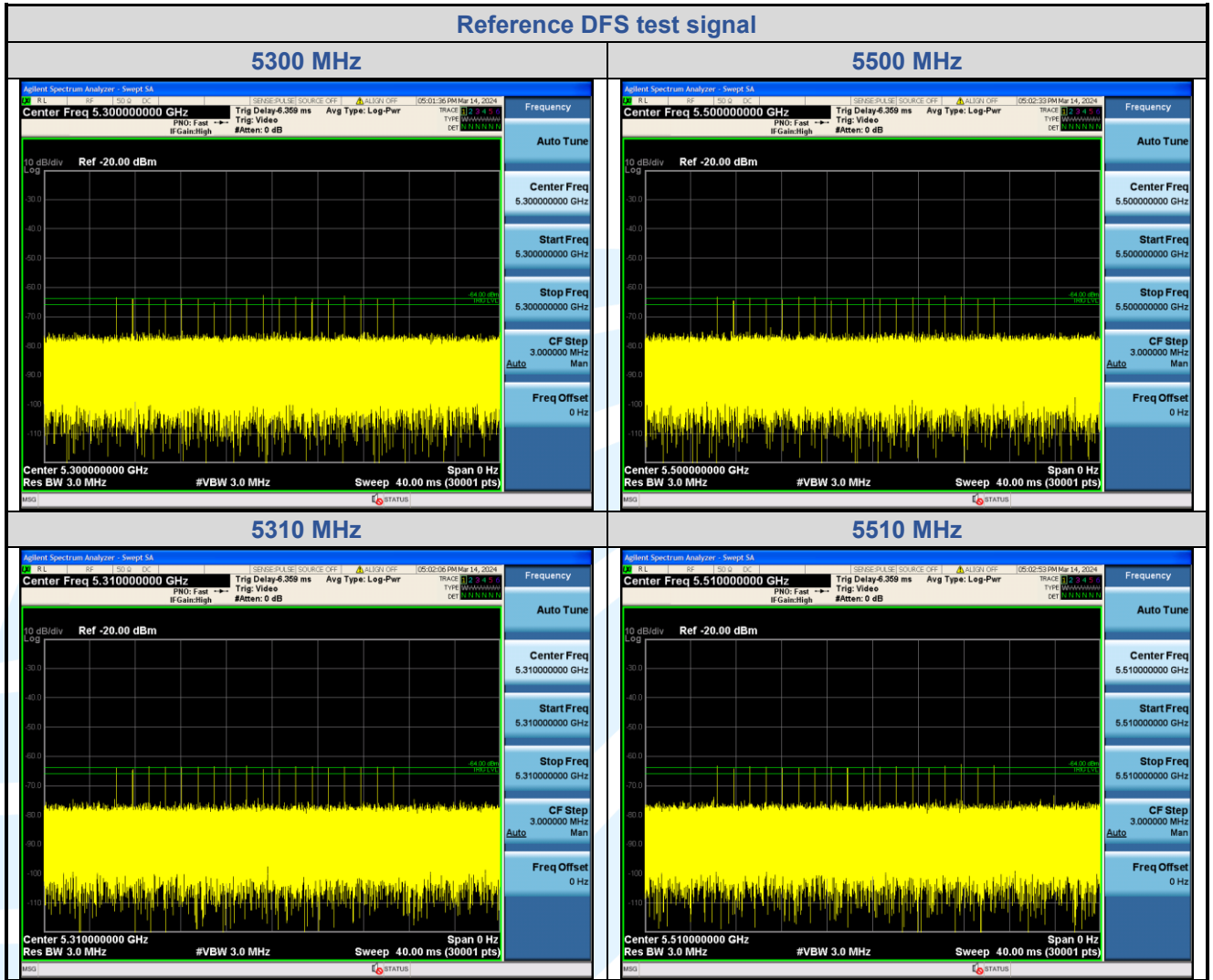

Shenzhen UnionTrust Quality and Technology Co., Ltd.

Address: Unit D/E of 9/F and 16/F, Block A, Building 6, Baoneng science and technology park, Longhua district, Shenzhen, China

Tel: +86-755-28230888

Fax: +86-755-28230886

E-mail: info@uttlab.com

<http://www.uttlab.com>

UTTR-RF-FCCPART15.407-V1.3

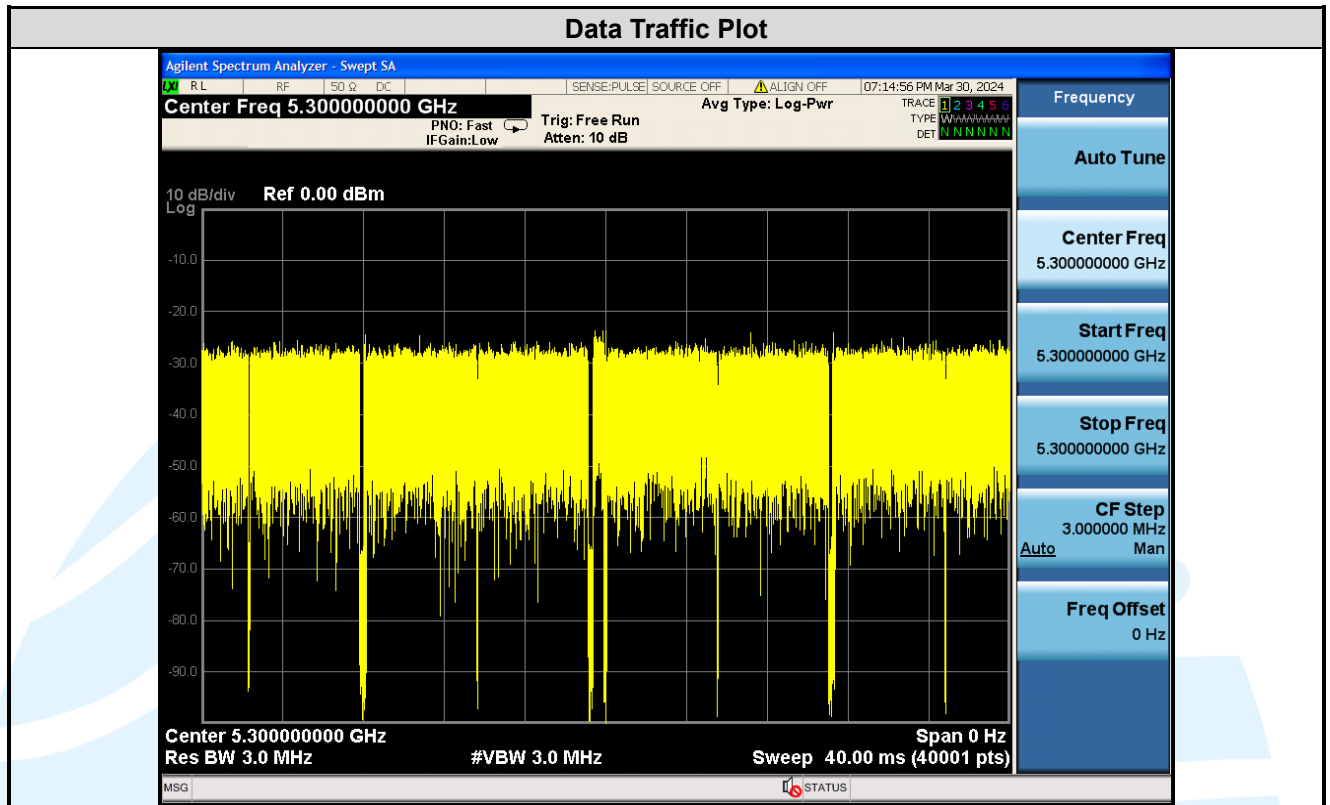

Shenzhen UnionTrust Quality and Technology Co., Ltd.

Address: Unit D/E of 9/F and 16/F, Block A, Building 6, Baoneng science and technology park, Longhua district, Shenzhen, China
Tel: +86-755-28230888 Fax: +86-755-28230886 E-mail: info@uttlab.com <http://www.uttlab.com>
<http://www.uttlab.com>
UTTR-RF-FCCPART15.407-V1.3

Channel Move Time & Channel Closing Transmission Time
802.11a_5300 MHz

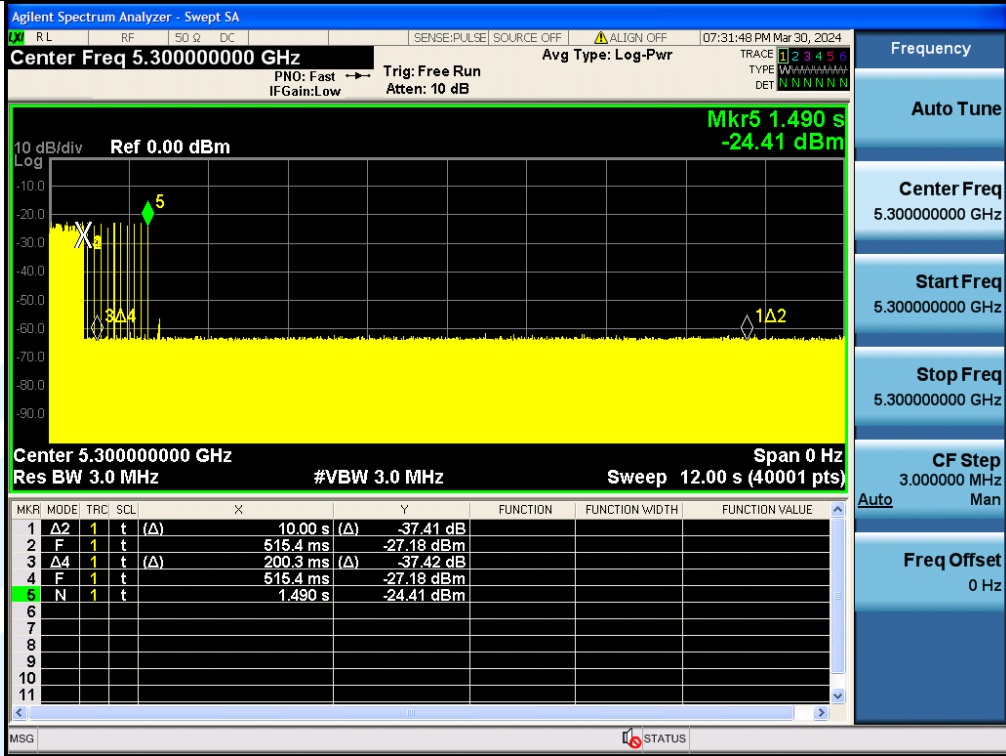

Note:

- 1) Mark1 Time: 515.4 ms, Mark2 Time: 10515.4 ms, Overtime Points: 25
- 2) Dwell = S/B = 12000 ms/40001 = 0.3 ms, C = N x Dwell = 25 x 0.3 = 7.5ms
- 3) CMT = 1.490s - 0.5154 s = 0.9746 s

Non-Occupancy Period_802.11a_CH60_5300 MHz

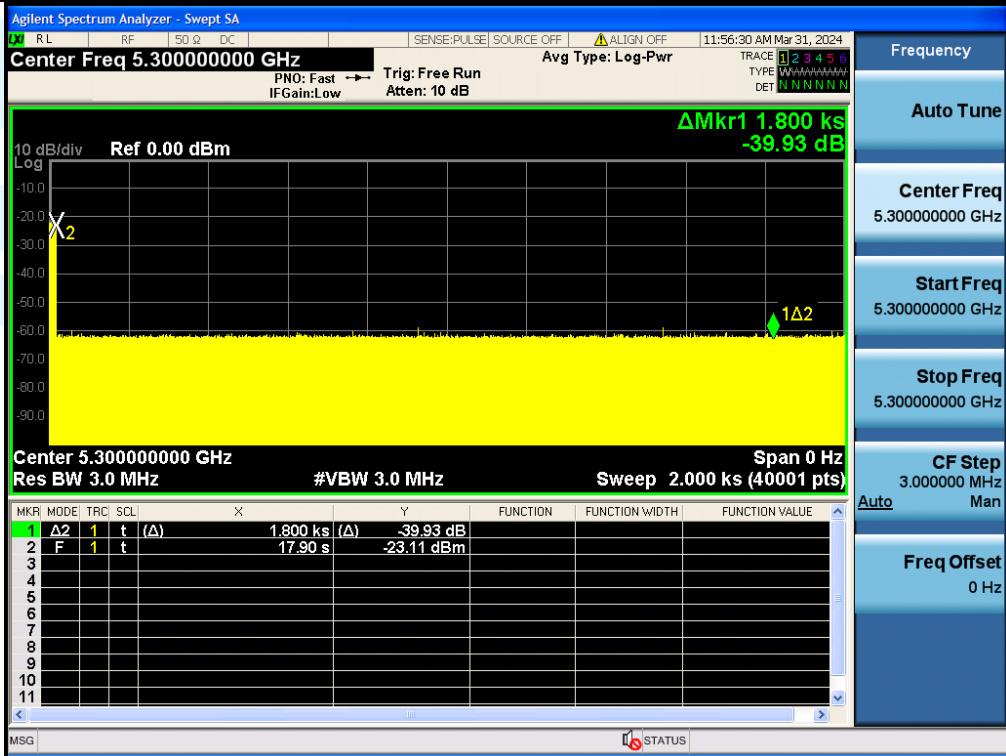

Shenzhen UnionTrust Quality and Technology Co., Ltd.

Address: Unit D/E of 9/F and 16/F, Block A, Building 6, Baoneng science and technology park, Longhua district, Shenzhen, China
 Tel: +86-755-28230888 Fax: +86-755-28230886 E-mail: info@uttlab.com <http://www.uttlab.com>
 UTR-RF-FCCPART15.407-V1.3

Channel Move Time & Channel Closing Transmission Time
802.11a_5500 MHz

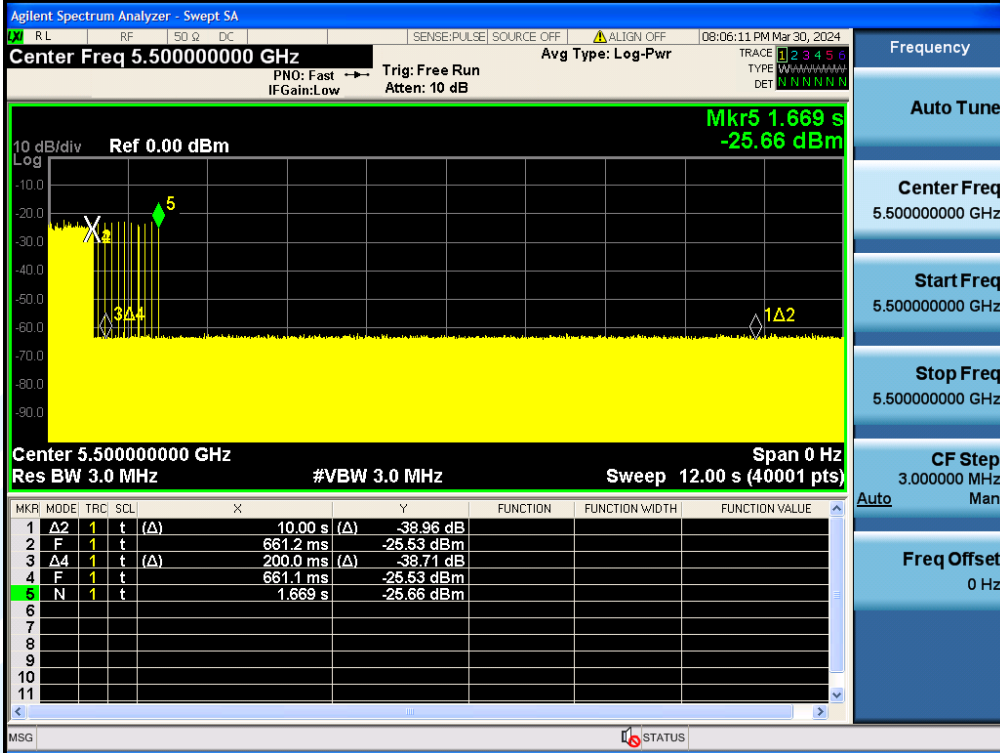

Note:

- 4) Mark1 Time: 661.2 ms, Mark2 Time: 10661.2 s, Ontime Points: 37
- 5) Dwell = S/B = 12000 ms/40001 = 0.3 ms, C = N x Dwell = 37 x 0.3 = 11.1 ms
- 6) CMT = 1.669 s - 0.6612s = 1.0078 s

Non-Occupancy Period_802.11a_CH100_5500 MHz

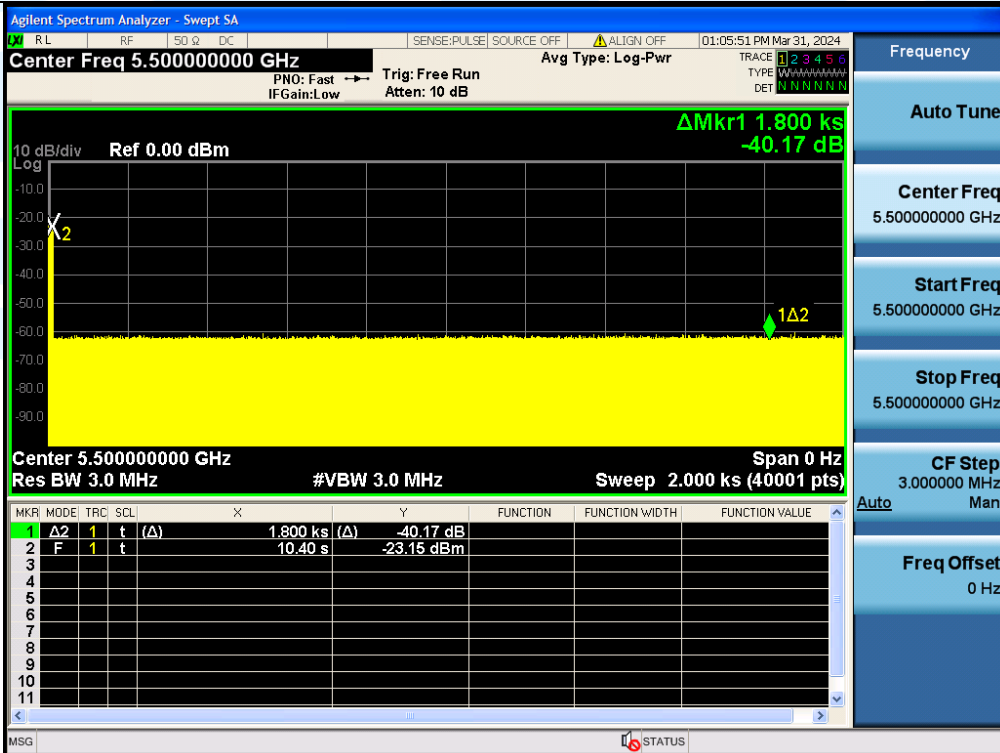

Shenzhen UnionTrust Quality and Technology Co., Ltd.

Address: Unit D/E of 9/F and 16/F, Block A, Building 6, Baoneng science and technology park, Longhua district, Shenzhen, China
 Tel: +86-755-28230888 Fax: +86-755-28230886 E-mail: info@uttlab.com <http://www.uttlab.com>
 UTR-RF-FCCPART15.407-V1.3

Channel Move Time & Channel Closing Transmission Time
802.11ac_5310 MHz



Note:

- 7) Mark1 Time: 686.4 ms, Mark2 Time: 10686.4 ms, Overtime Points: 19
- 8) Dwell = S/B = 12000 ms/40001 = 0.3 ms, C = N x Dwell = 105 x 0.3 = 31.5ms
- 9) CMT = 1.654 s - 0.6864 s = 0.9676 s

Non-Occupancy Period_802.11ac_CH58_5310 MHz

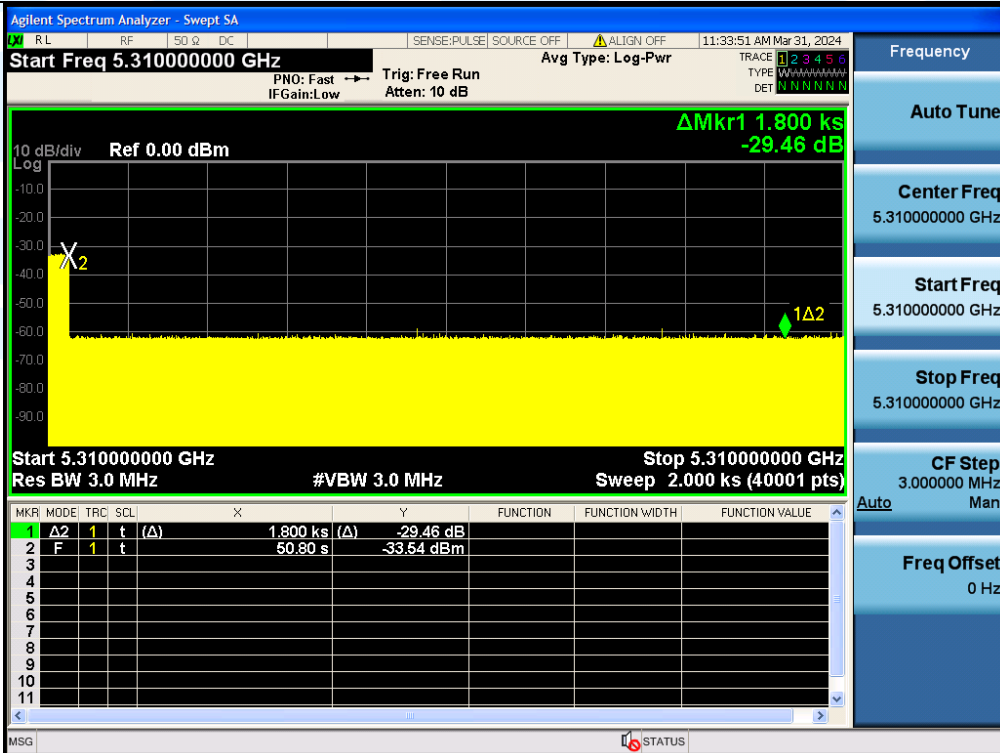

Channel Move Time & Channel Closing Transmission Time
802.11ac_5510 MHz



Note:

- 10) Mark1 Time: 221.4 ms, Mark2 Time: 10221.4 ms, Ontime Points: 72
- 11) Dwell = S/B = 12000 ms/40001 = 0.3 ms, C = N x Dwell = 72 x 0.3 = 21.6 ms
- 12) CMT = 1.552 s - 0.2214 s = 1.3306 s

Non-Occupancy Period_802.11ac_CH106_5510 MHz

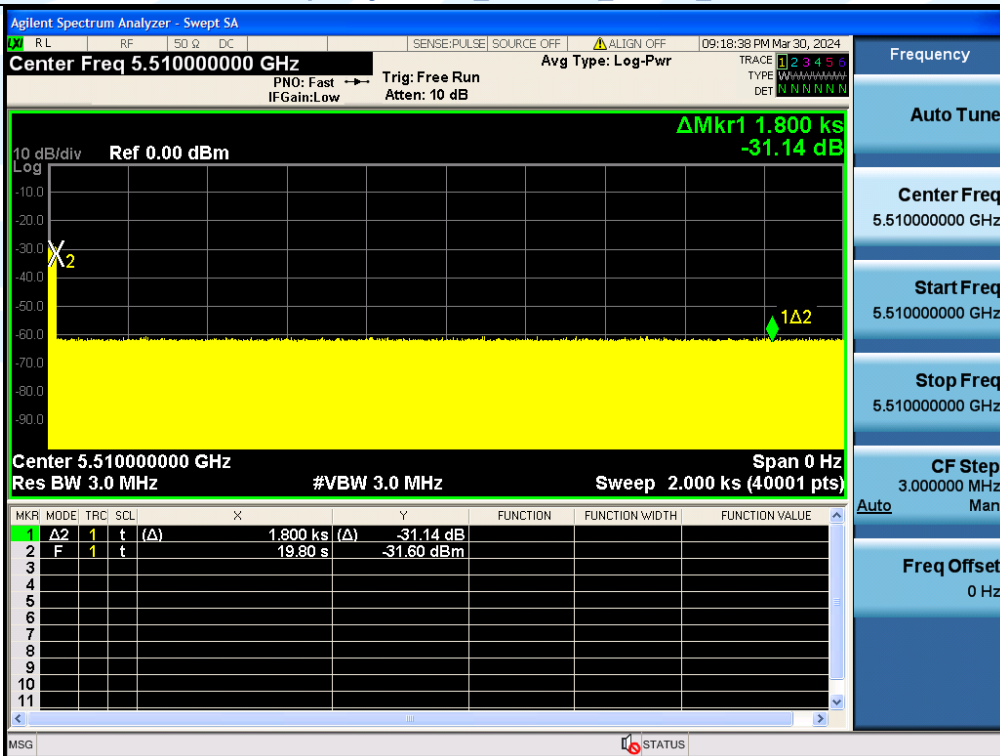

5.9 AC POWER LINE CONDUCTED EMISSION

Test Requirement: FCC 47 CFR Part 15 Subpart C Section 15.207

Test Method: ANSI C63.10-2013, Section 6.2.

Limits:

Frequency range (MHz)	Limits (dB(μV))	
	Quasi-peak	Average
0,15 to 0,50	66 to 56	56 to 46
0,50 to 5	56	46
5 to 30	60	50

Remark:

1. The lower limit shall apply at the transition frequencies.
2. The limit decreases linearly with the logarithm of the frequency in the range 0.15 to 0.50 MHz.

Test Setup: Refer to section 4.5.2 for details.

Test Procedures:

Test frequency range :150KHz-30MHz

- 1) The mains terminal disturbance voltage test was conducted in a shielded room.
- 2) The EUT was connected to AC power source through a LISN 1 (Line Impedance Stabilization Network) which provides a 50Ω/50μH + 5Ω linear impedance. The power cables of all other units of the EUT were connected to a second LISN 2, which was bonded to the ground reference plane in the same way as the LISN 1 for the unit being measured. A multiple socket outlet strip was used to connect multiple power cables to a single LISN provided the rating of the LISN was not exceeded.
- 3) The tabletop EUT was placed upon a non-metallic table 0.8m above the ground reference plane. And for floor-standing arrangement, the EUT was placed on the horizontal ground reference plane,
- 4) The test was performed with a vertical ground reference plane. The rear of the EUT shall be 0.4 m from the vertical ground reference plane. The vertical ground reference plane was bonded to the horizontal ground reference plane. The LISN 1 was placed 0.8 m from the boundary of the unit under test and bonded to a ground reference plane for LISNs mounted on top of the ground reference plane. This distance was between the closest points of the LISN 1 and the EUT. All other units of the EUT and associated equipment was at least 0.8 m from the LISN 2.
- 5) In order to find the maximum emission, the relative positions of equipment and all of the interface cables must be changed according to ANSI C63.10 on conducted measurement.

Equipment Used: Refer to section 3 for details.

Test Result: Pass

The worst measurement data as follows:
 Quasi Peak and Average:
 Mode: WIFI Link

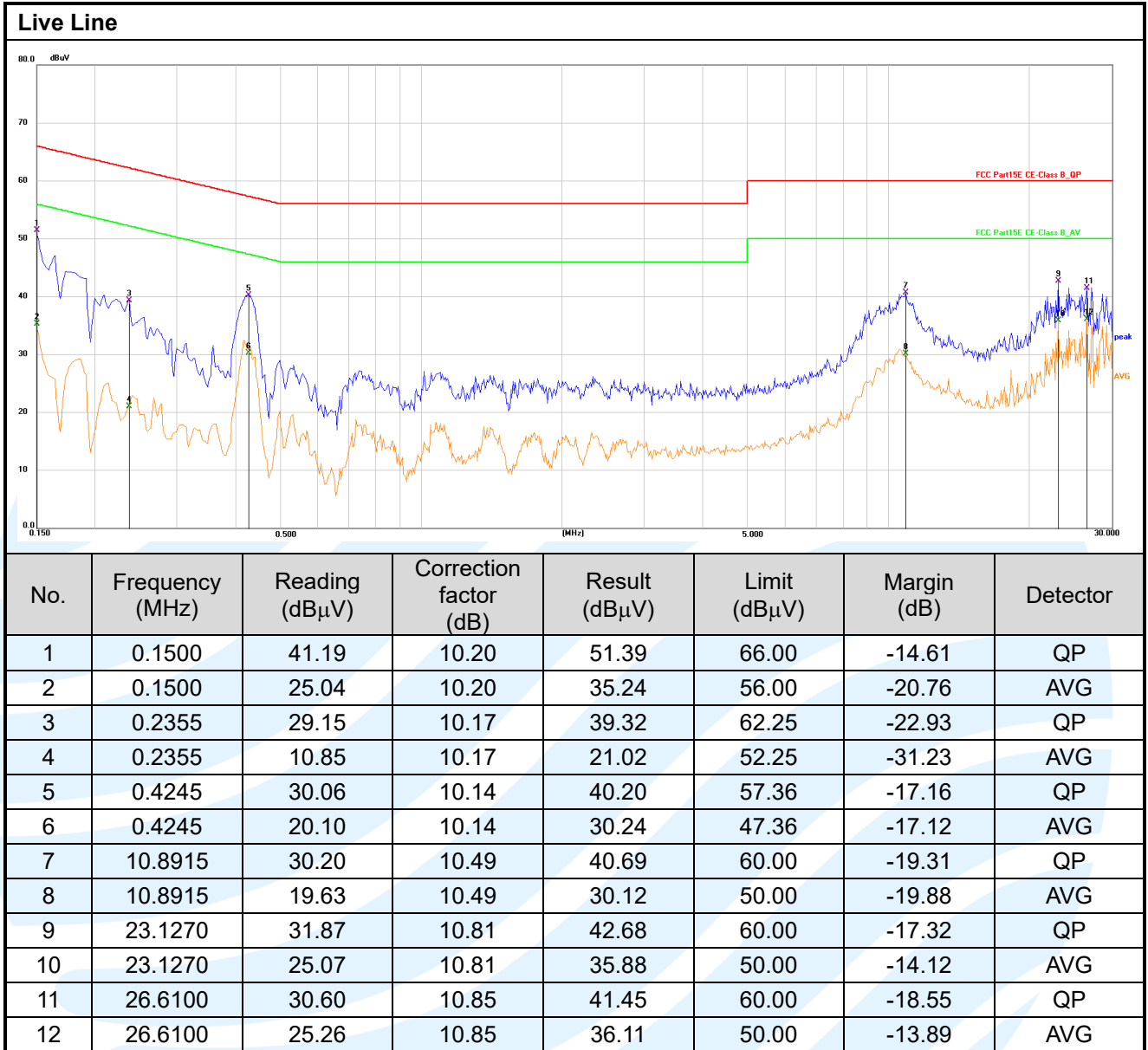

Shenzhen UnionTrust Quality and Technology Co., Ltd.

Address: Unit D/E of 9/F and 16/F, Block A, Building 6, Baoneng science and technology park, Longhua district, Shenzhen, China
 Tel: +86-755-28230888 Fax: +86-755-28230886 E-mail: info@uttlab.com <http://www.uttlab.com>
 UTR-RF-FCCPART15.407-V1.3