



Ke Mei Ou Lab Corp.



2013-2016, 20th Floor, Business Center, Jiahui Xin Cheng, No 3027,
Shen Nan Road, Fu Tian, Shen Zhen, Guang Dong, P. R. China
Tel: + 86 755 83642690 Fax: + 86 755 83297077
www.kmolab.com

FCC TEST REPORT

Under:
FCC Part 15 Subpart B, Class B
JBP-Part 15 Class B Computing Device Peripheral

Prepared For :
Grandstream Networks, Inc.
126 Brookline Ave, 3rd Floor Boston, MA 02215, USA

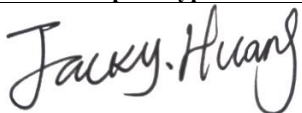
FCC ID: YZZGDS3705
EUT: IP Audio Door System
Model: GDS3705

May 30, 2018 Issue Date:
Original Report Report Type:
 Test Engineer: Jacky Huang
 Review By: Apollo Liu / Manager

The test report consists 33 pages in total. It may be duplicated completely for legal use with the allowance of the applicant. It shall not be reproduced except in full, without the written approval of Ke Mei Ou Laboratory Corporation. The test result in the report only applied to the tested sample.

Table of Contents

1. General Information	4
1. 1 Notes.....	4
1. 3 Details of Applicant.....	4
1. 4 Application Details	4
1. 5 Details of Manufacturer.....	4
1. 6 Test Item	4
1. 7 Applicable Standards	5
2. Technical Test.....	6
2. 1 Summary of Test Results	6
2. 2 Measurement Uncertainty.....	6
3. EUT Modifications	6
4. Conducted Power Line Test.....	7
4. 1 Test Equipment.....	7
4. 2 Test Procedure	7
4. 3 Test Setup	7
4. 4 Configuration of the EUT.....	8
4. 5 EUT Operating Condition.....	9
4. 6 Conducted Power Line Emission Limits	9
4. 7 Conducted Power Line Test Result.....	10
5. Radiated Emission Test.....	12
5. 1 Test Equipment.....	12
5. 2 Test Procedure	12
5. 3 Radiated Test Setup	12
5. 4 Configuration of The EUT.....	14
5. 5 EUT Operating Condition.....	14
5. 6 Radiated Emission Limit	14
5. 7 Radiated Emission Test Result.....	15
6. Photo of Testing.....	17
6.1 Emission test view.....	17
6.2 Photograph - EUT.....	19
7. FCC ID Label.....	32
8. Test Equipment.....	33

Report Revision History

Report #	Version	Description	Issued Date
KSZ2018032301J02	Rev.01	Initial issue of report	April 23, 2018
KSZ2018032301J02	Rev.01	Update section 4.7 & 6.2 & 8	May 30, 2018

1. General Information

1.1 Notes

The test results of this report relate exclusively to the test item specified in 1.6. The KMO Lab does not assume responsibility for any conclusions and generalizations drawn from the test results with regard to other specimens or samples of the type of the equipment represented by the test item. The test report may only be reproduced or published in full. Reproduction or publication of extracts from the report requires the prior written approval of the KMO Lab.

Test Firm Name:	Ke Mei Ou Lab Co., Ltd.
Test Firm Address:	2013-2016, 20th Floor, Business Center, Jiahui Xin Cheng, No 3027, Shen Nan Road, Fu Tian, Shen Zhen, Guang Dong, P. R. China
FCC Designation Number:	CN1532
Test Firm Registration Number:	344480
Internet:	www.kmolab.com
Email:	kmo@kmolab.com
ANSI-ASQ National Accreditation Board/ACLASS ISO/IEC 17025 Accredited Lab for telecommunication standards. The Registration Number is AT-1532. The testing quality system meets with ISO/IEC-17025 requirements, This approval results is accepted by MRA of ILAC.	

1.3 Details of Applicant

Name: Grandstream Networks, Inc.
Address: 126 Brookline Ave, 3rd Floor Boston, MA 02215, USA

1.4 Application Details

Date of Receipt of Application: March 23, 2018
Date of Receipt of Test Item: March 23, 2018
Date of Test: March 28~May 30, 2018

1.5 Details of Manufacturer

Name: Grandstream Networks, Inc.
Address: 126 Brookline Ave, 3rd Floor Boston, MA 02215, USA

1.6 Test Item

EUT Feature	
EUT Description:	IP Audio Door System
Brand Name:	Grandstream
Model Name:	GDS3705
EUT RF Technology:	<input checked="" type="checkbox"/> DCD - Part 15 Low Power Transmitter Below 1705 kHz
HW Version:	v1.4A
SW Version:	1.0.0.23
EUT Stage:	Identical Prototype
Note: The above EUT's information was declared by manufacturer. Please refer to the specifications or user's manual for more detailed description.	

Standard Product Specification	
Channel Frequency:	125 kHz
Channel Number:	1
Type of Modulation	ASK
EUT Operational Condition	<input type="checkbox"/> AC <input checked="" type="checkbox"/> DC → <input type="checkbox"/> From Battery <input type="checkbox"/> External AC adapter <input checked="" type="checkbox"/> POE

Additional Information

Specification of Accessory				
<input type="checkbox"/> AC/DC Adapter #1 (US)	Brand Name	-	Model Name	-
	Power Rating	-		
<input type="checkbox"/> AC/DC Adapter #2 (US)	Brand Name	-	Model Name	-
	Power Rating	-		

1.7 Applicable Standards

Applicable Standards
According to the specifications of the manufacturer, the EUT must comply with the requirements of the following standards: FCC Part 15 Subpart B ANSI C63.4-2014
Note: All test items were verified and recorded according to the standards and without any deviation during the test.

2. Technical Test

2.1 Summary of Test Results

The EUT has been tested according to the following specifications:

FCC Rules	Test Type	Limit	Result	Notes
FCC Part 15, Paragraph 15.107	AC Conducted Test	< 15.107 Limits	PASS	Complies.
FCC Part 15, Paragraph 15.109	Radiated Test	< 15.109 Limits	PASS	Complies.

2.2 Measurement Uncertainty

Measurement	Frequency	Uncertainty
Conducted emissions	0.15MHz~30MHz	1.72
Radiated emissions	30MHz ~ 300MHz	3.88
Radiated emissions	300MHz ~1000MHz	3.86
Radiated emissions	>1000MHz	4.42

This uncertainty represents an expanded uncertainty expressed at approximately the 95% confidence level using a coverage factor of k=2.

3. EUT Modifications

No modification by test lab.

4. Conducted Power Line Test

4.1 Test Equipment

Please refer to Section 8 this report.

4.2 Test Procedure

Test Method	
<input checked="" type="checkbox"/>	<p>The EUT and simulators are connected to the main power through a line impedance stabilization network (L.I.S.N.). This provides a 50 ohm/50uH coupling impedance for the measuring equipment. The peripheral devices are also connected to the main power through a LISN that provides a 50ohm/50uH coupling impedance with 50ohm termination.</p> <p>Both sides of A.C. line are checked for maximum conducted interference. In order to find the maximum emission., the relative positions of equipment and all of the interface cables must be changed according to ANSI C63.4:2014 on conducted measurement. Conducted emissions were investigated over the frequency range from 0.15MHz to 30MHz using a receiver bandwidth of 9kHz.</p>

4.3 Test Setup

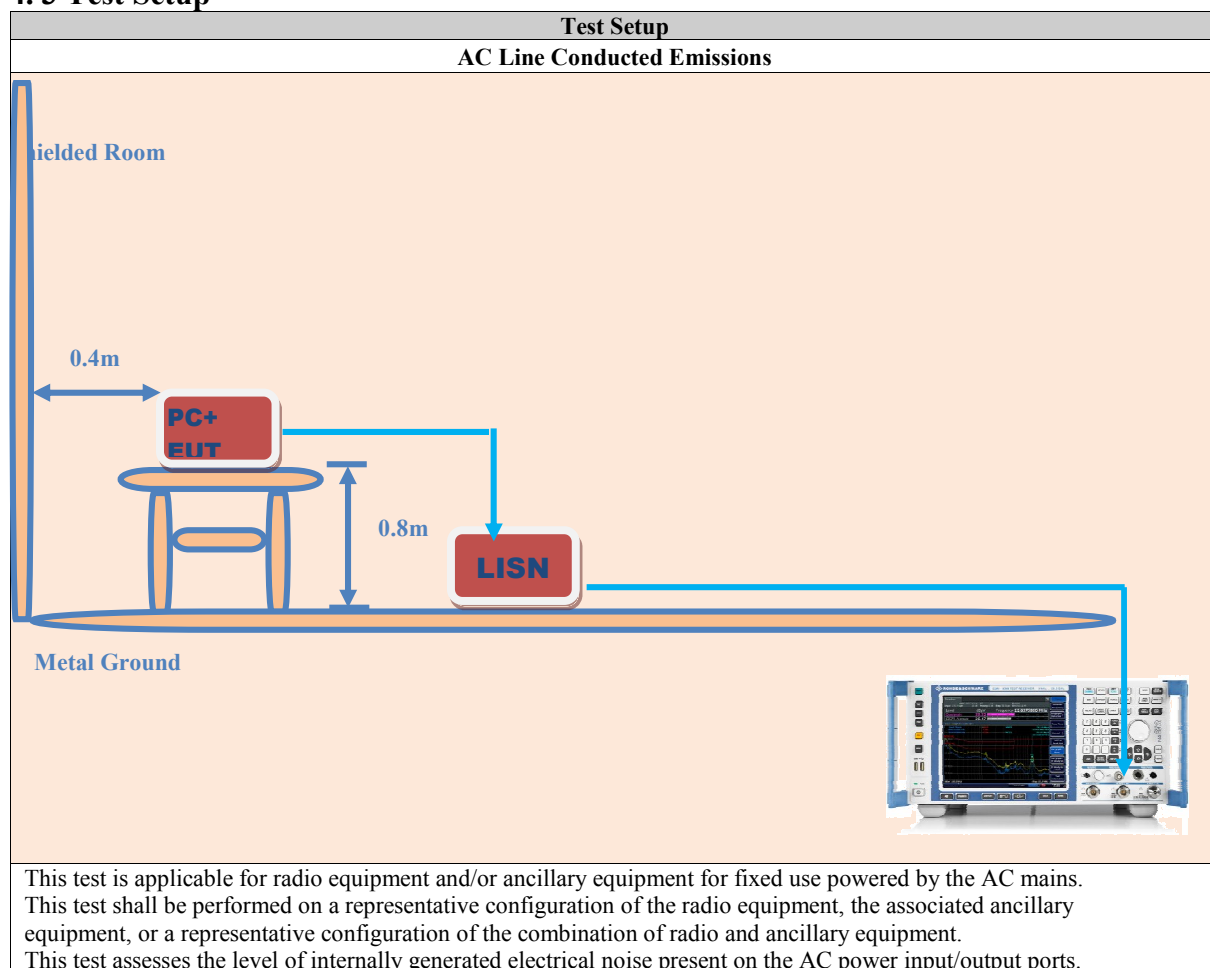

4.4 Configuration of the EUT

The EUT was configured according to ANSI C63.4:2014. All interface ports were connected to the appropriate peripherals. All peripherals and cables are listed below.

EUT Operation Test Setup			
<input checked="" type="checkbox"/>	Operated Mode		
<input checked="" type="checkbox"/>	Talking	<input type="checkbox"/>	Other

The Worst Case Mode for Following Conformance Tests			
<input checked="" type="checkbox"/>	Tests Item		
<input checked="" type="checkbox"/>	AC power-line conducted emissions	<input checked="" type="checkbox"/>	Radiated Field Strength
<input checked="" type="checkbox"/>	Condition		
<input checked="" type="checkbox"/>	AC power-line conducted measurement for line and neutral Test Voltage: 120Vac / 60Hz	<input checked="" type="checkbox"/>	Radiated measurement
<input checked="" type="checkbox"/>	Operating Mode		
<input checked="" type="checkbox"/>	Operating Mode Description	<input type="checkbox"/>	Other
<input checked="" type="checkbox"/>	Orthogonal Planes of EUT		
<input type="checkbox"/>	X Plane	<input type="checkbox"/>	Y Plane
<input checked="" type="checkbox"/>	Y Plane	<input type="checkbox"/>	Other

Support Unit				
Device	Manufacturer	Model # Serial #	FCC ID	Cable
Notebook	ACER	ZQE	HLZ-AR5B97	1.5m unshielded power cord
AC/DC Adapter ^{Note}	Frecom	F18W8-120150SPAUY	DOC	1.5m unshielded power cord

Note: Support for AC power-line conducted emission testing only.

4.5 EUT Operating Condition

Operating condition is according to ANSI C63.4:2014.
Connect EUT to an IP phone and enable talking

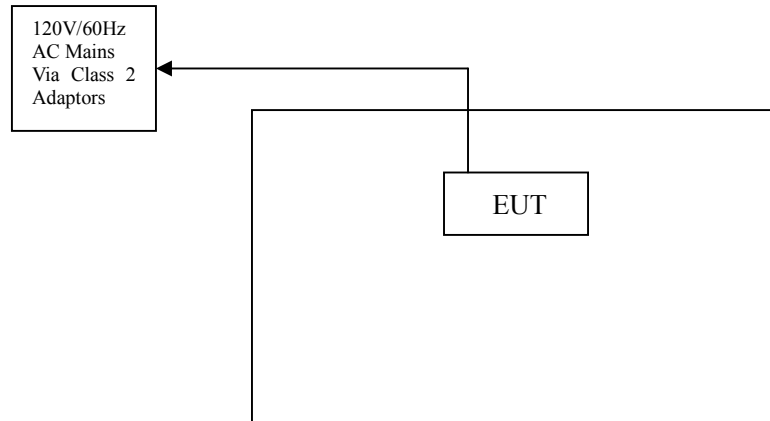

4.6 Conducted Power Line Emission Limits

Frequency Range (MHz)	Class A QP/AV (dBuV)	Class B QP/AV (dBuV)
0.15 – 0.5	79/66	66 –56/56 –46
0.5 – 5.0	73/60	56/46
5.0 – 30	73/60	60/50

Note: In the above table, the tighter limit applies at the band edges.

4.7 Conducted Power Line Test Result

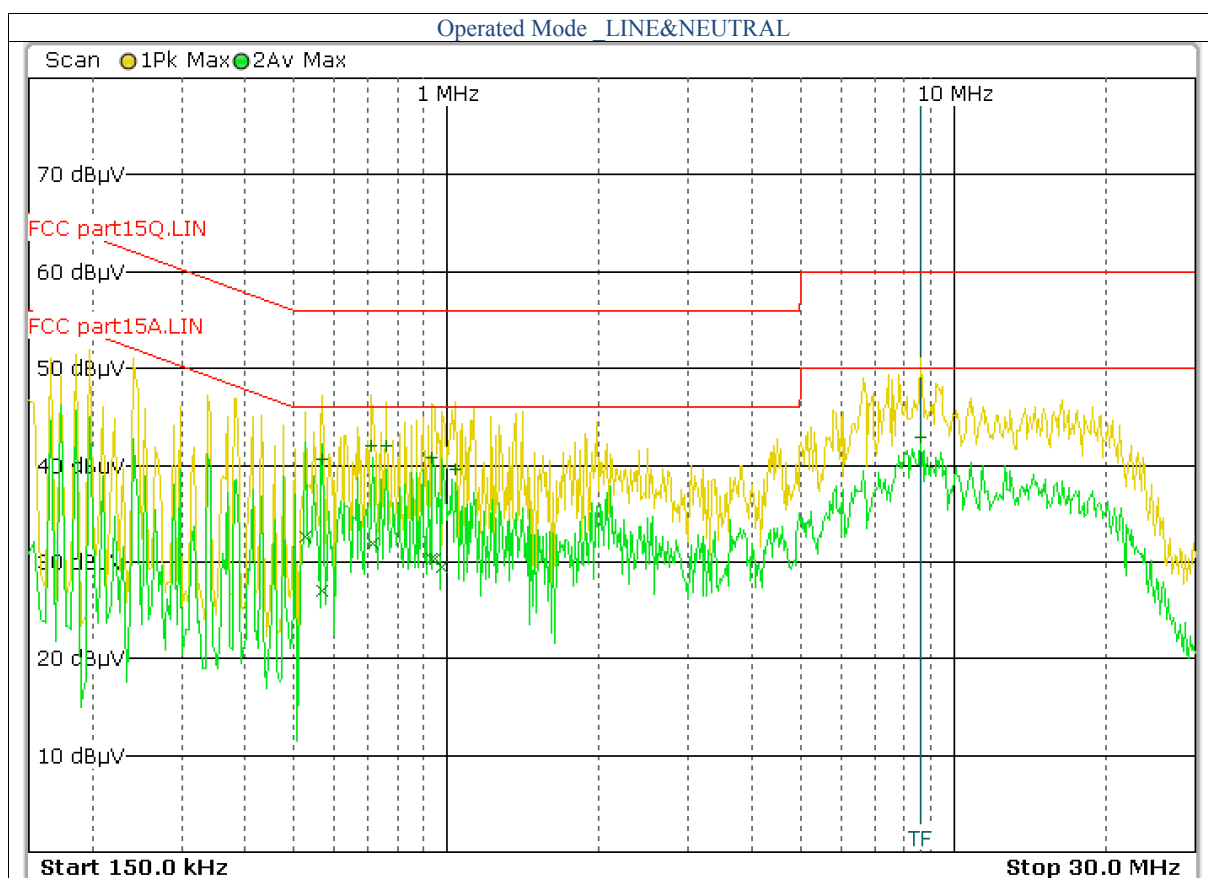

FCC15										
Frequency (MHz)	Read Level (dBUV)		Factor (dB)	Emission (dBUV)		Line/Neutral	Limit (dBUV)		Margin(dBUV)	
	QP	AV		QP	AV		QP	AV	QP	AV
0.526	29.83	22.17	10.40	40.23	32.57	Line	56.00	46.00	-15.77	-13.43
0.570	30.22	16.67	10.40	40.62	27.07	Line	56.00	46.00	-15.38	-18.93
0.710	31.58	21.47	10.40	41.98	31.87	Line	56.00	46.00	-14.02	-14.13
0.758	31.55	20.45	10.40	41.95	30.85	Line	56.00	46.00	-14.05	-15.15
0.938	30.46	19.97	10.40	40.86	30.37	Line	56.00	46.00	-15.14	-15.63
0.946	28.27	19.84	10.40	38.67	30.24	Line	56.00	46.00	-17.33	-15.76
1.038	29.06	17.74	10.50	39.56	28.24	Line	56.00	46.00	-16.44	-17.76
8.610	32.12	20.63	10.70	42.82	31.33	Line	60.00	50.00	-17.18	-18.67

Note:

- 1.Uncertainty in conducted emission measured is <+/- 2dB.
- 2.The emission levels of other frequencies were very low against the limit.
- 3.All Reading Levels are Quasi-Peak and Average value.
- 4.Emission = Meter Reading + Factor; Factor = Insertion Loss + Cable Loss.
- 5.Margin Value= Emission Level - Limit Value.

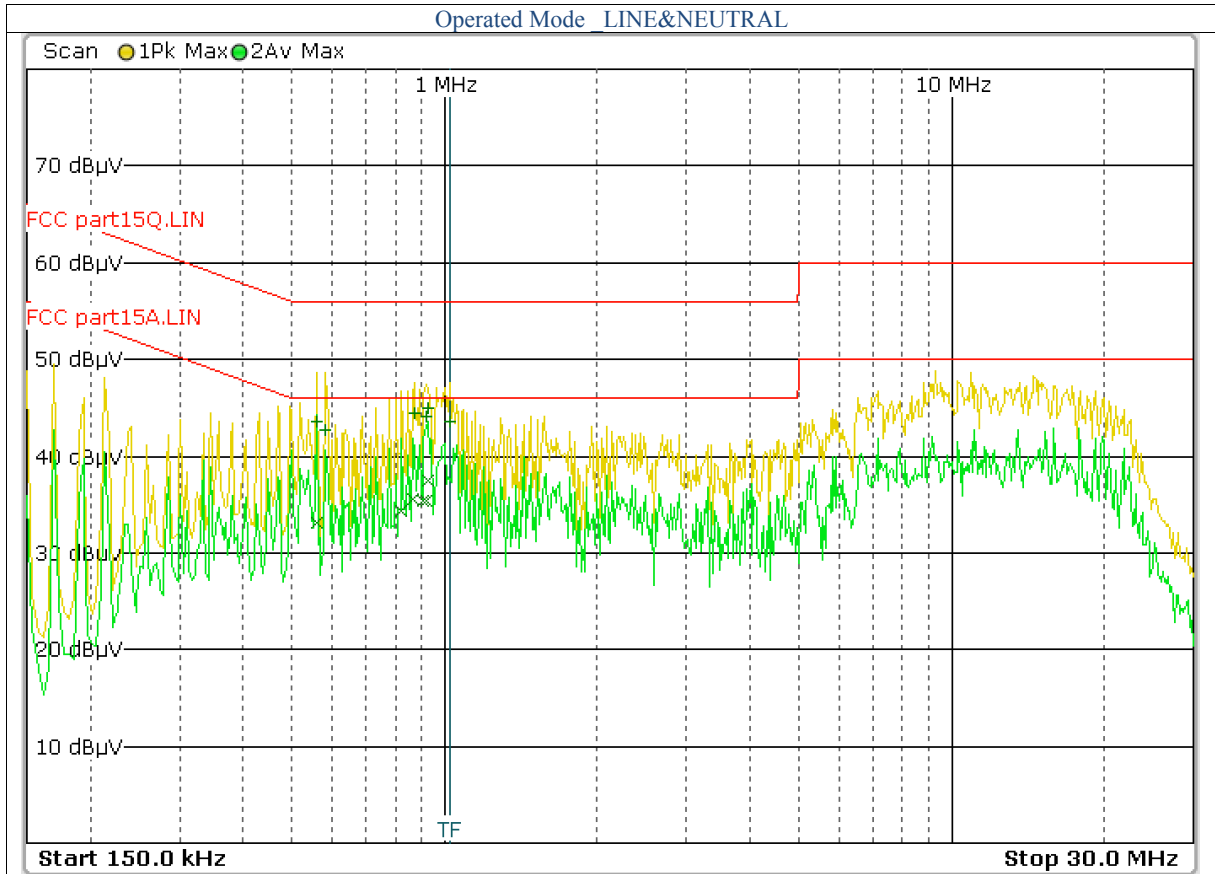

FCC15										
Frequency (MHz)	Read Level (dBuV)		Factor (dB)	Emission (dBuV)		Line/Neutral	Limit (dBuV)		Margin(dBuV)	
	QP	AV		QP	AV		QP	AV	QP	AV
0.558	33.26	22.65	10.40	43.66	33.05	Neutral	56.00	46.00	-12.34	-12.95
0.582	32.26	20.63	10.40	42.66	31.03	Neutral	56.00	46.00	-13.34	-14.97
0.870	33.96	25.08	10.40	44.36	35.48	Neutral	56.00	46.00	-11.64	-10.52
0.918	33.66	24.99	10.40	44.06	35.39	Neutral	56.00	46.00	-11.94	-10.61
0.926	34.52	27.00	10.40	44.92	37.40	Neutral	56.00	46.00	-11.08	-8.60
1.022	33.12	20.84	10.40	43.52	31.24	Neutral	56.00	46.00	-12.48	-14.76

Note:

- 1.Uncertainty in conducted emission measured is <+/- -2dB.
- 2.The emission levels of other frequencies were very low against the limit.
- 3.All Reading Levels are Quasi-Peak and Average value.
- 4.Emission = Meter Reading + Factor; Factor = Insertion Loss + Cable Loss.
- 5.Margin Value= Emission Level - Limit Value.

5. Radiated Emission Test

5.1 Test Equipment

Please refer to Section 8 this report.

5.2 Test Procedure

1. The EUT was tested according to ANSI C63.4:2014.
2. The EUT, peripherals were put on the turntable which table size is 1m x 1.5 m, table high 0.8 m, and which is 1.5 m high for above 1 GHz. All set up is according to ANSI C63.4:2014 .
3. The frequency spectrum from 9 kHz to 25 GHz was investigated. All readings from 9 kHz to 150 kHz are quasi-peak values with a resolution bandwidth of 200 Hz. All readings from 150 kHz to 30 MHz are quasi-peak values with a resolution bandwidth of 9 KHz. All readings from 30 MHz to 1 GHz are quasi-peak values with a resolution bandwidth of 120 KHz. All readings are above 1 GHz , peak values with a resolution bandwidth of 1 MHz . Measurements were made at 3 meters.
4. The emissions from the EUT were measured continuously at every azimuth by rotating the turntable. The Receiving antenna high is varied from 1 m to 4 m high to find the maximum emission for each frequency. Emissions below 30MHz were measured with a loop antenna while emission above 30MHz were measured using a broadband E-field antenna.
5. Maximizing procedure was performed on the six (6) highest emissions to ensure EUT compliance is with all installation combinations. All data was recorded in the peak detection mode. Quasi-peak readings was performed only when an emission was found to be marginal (within -4 dB of specification limit), and are distinguished with a "QP" in the data table.
6. Each emission was to be maximized by changing the polarization of receiving antenna both horizontal and vertical. In order to find out the max. emission, the relative positions of this transmitter(EUT) was rotated through three orthogonal axes according to the requirements in Section 8 and 13 of ANSI C63.4:2014

5.3 Radiated Test Setup

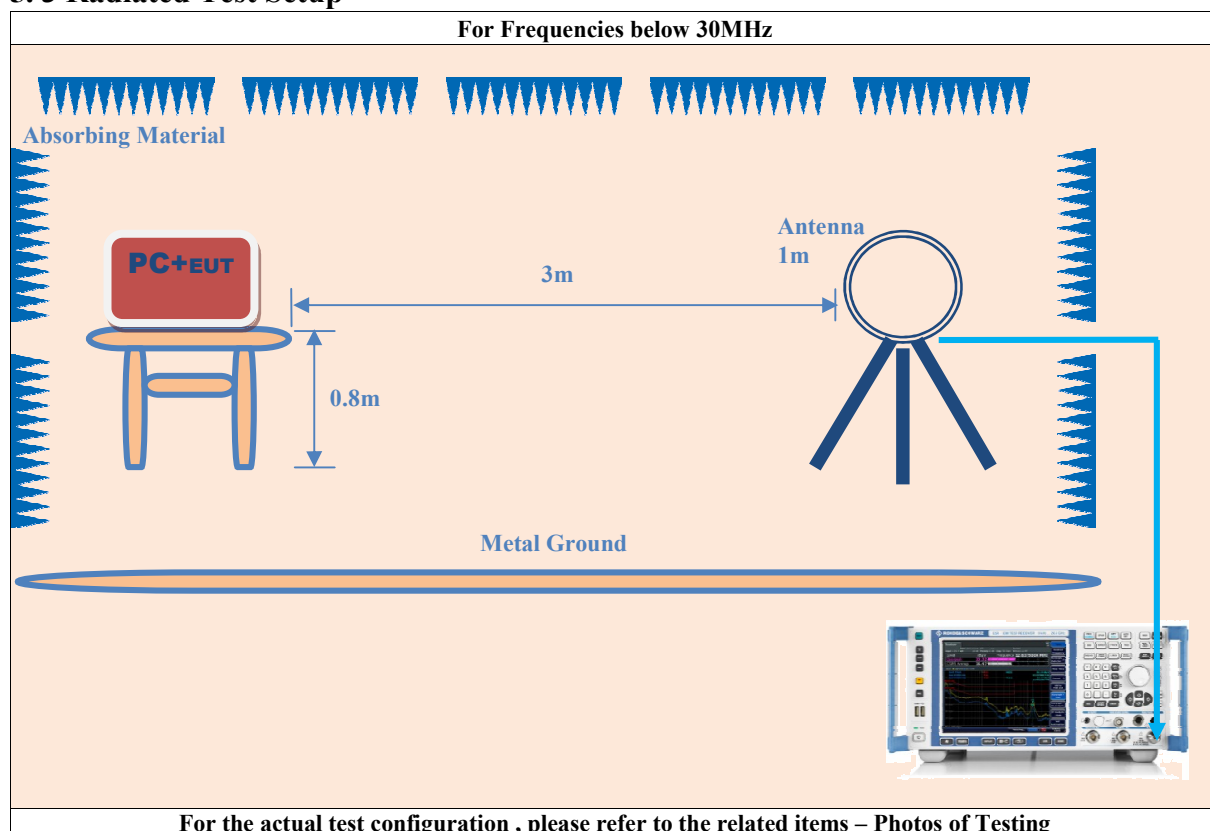

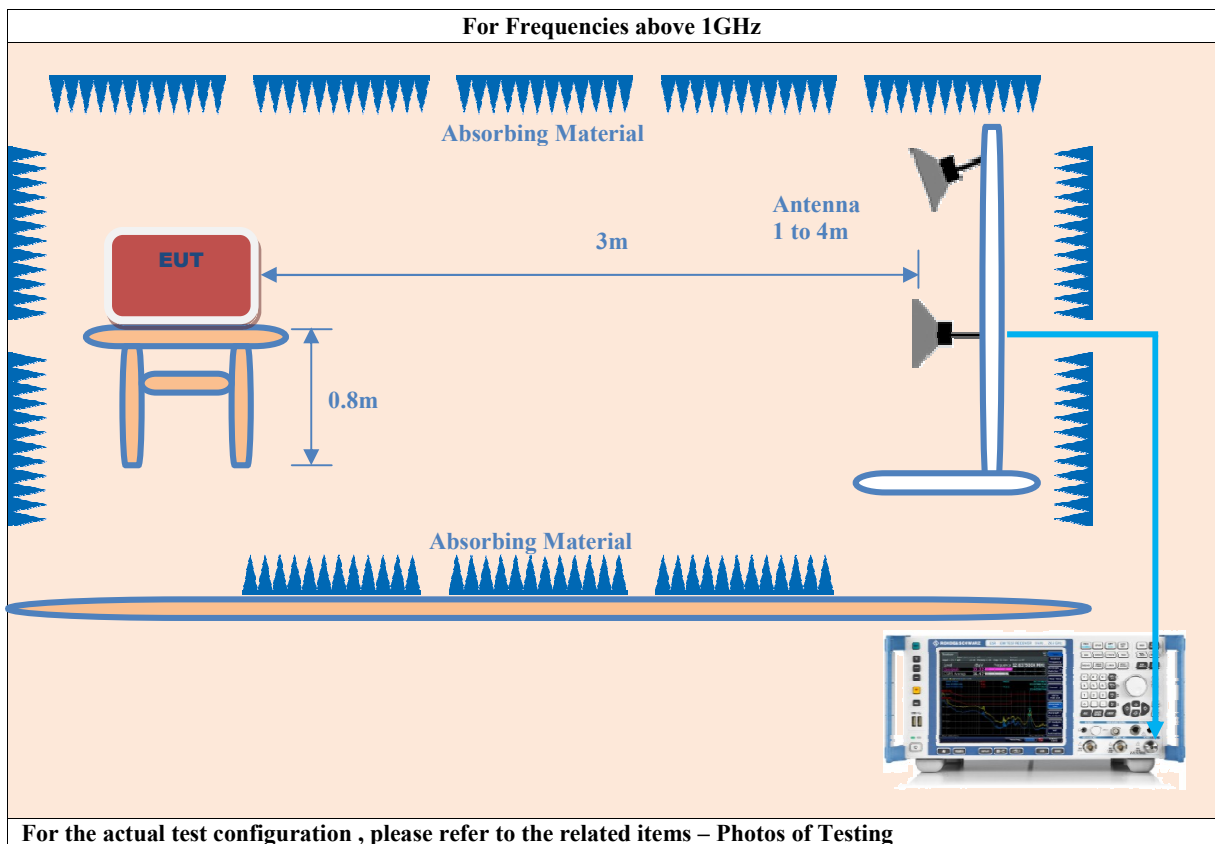
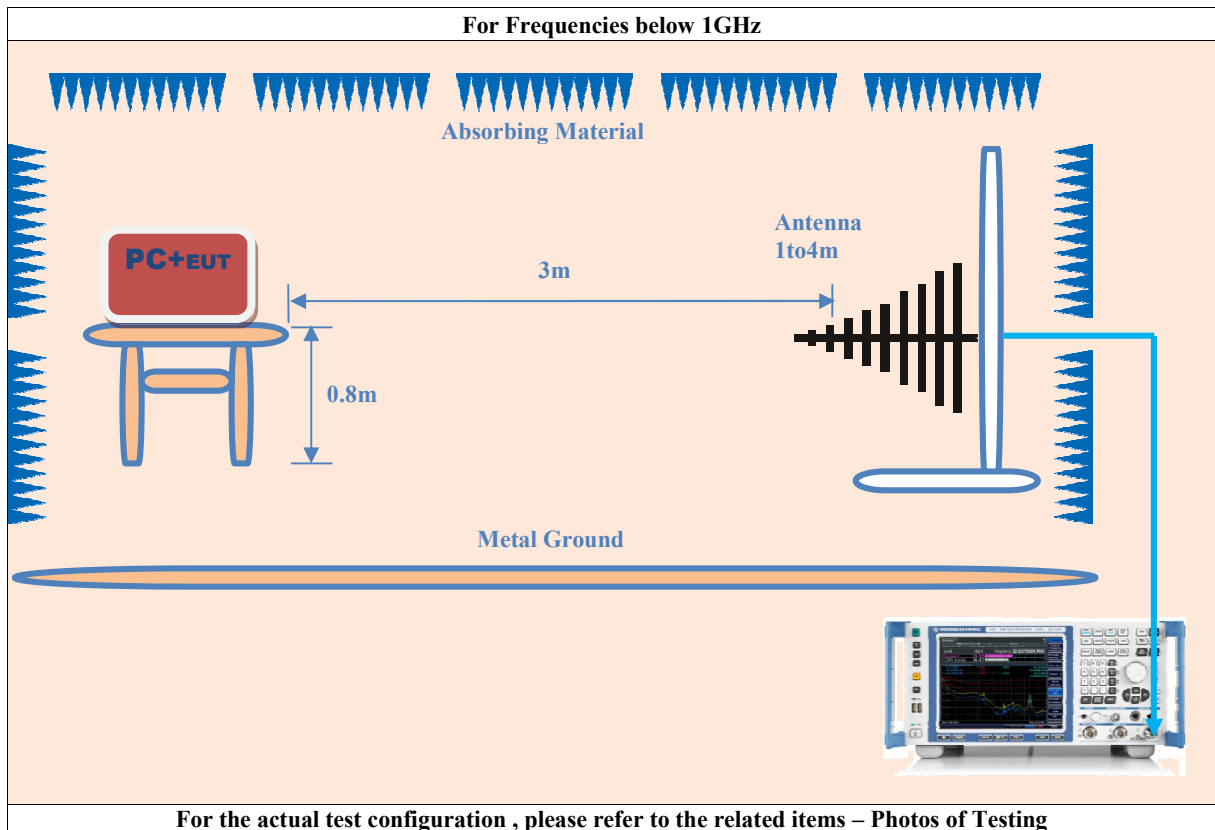

5.4 Configuration of The EUT

Same as section 4.4 of this report

5.5 EUT Operating Condition

Same as section 4.5 of this report

5.6 Radiated Emission Limit

All emission from a digital device, including any network of conductors and apparatus connected thereto, shall not exceed the level of field strength specified below:

Frequencies in restricted band are complied to limit on Paragraph 15.109.

Frequency (MHz)	Distance (m)	Field Strength (dBuV/m)
30 - 88	3	40.0
88 - 216	3	43.5
216 - 960	3	46.0
Above 960	3	54.0

Note:

1. In the emission tables above, the tighter limit applies at the band edges.
2. Distance refers to the distance between measuring instrument, antenna, and the closest point of any part of the device or system.
3. The lower limit shall apply at the transition frequencies.

5.7 Radiated Emission Test Result

For Frequency below 30MHz

Frequency (MHz)	Read Level (dBuV)	Factor (dB)	Emission (dBuV/m)	Horiz./Vert.	Limit (dBuV/m)	Margin (dB)
N/A						
N/A						
N/A						
N/A						
N/A						
N/A						

- Note:**
- (1) All Readings below 1GHz are Quasi-Peak, above are performed with peak and/or average measurements as necessary.
 - (2) "N/A" remark, if no specific emissions from the EUT are recorded (ie: margin>20dB from the applicable limit) and considered that's already beyond the background noise floor.
 - (3) Emission Level = Reading Level + Probe Factor + Cable Loss.

For Frequency from 30MHz to 1GHz

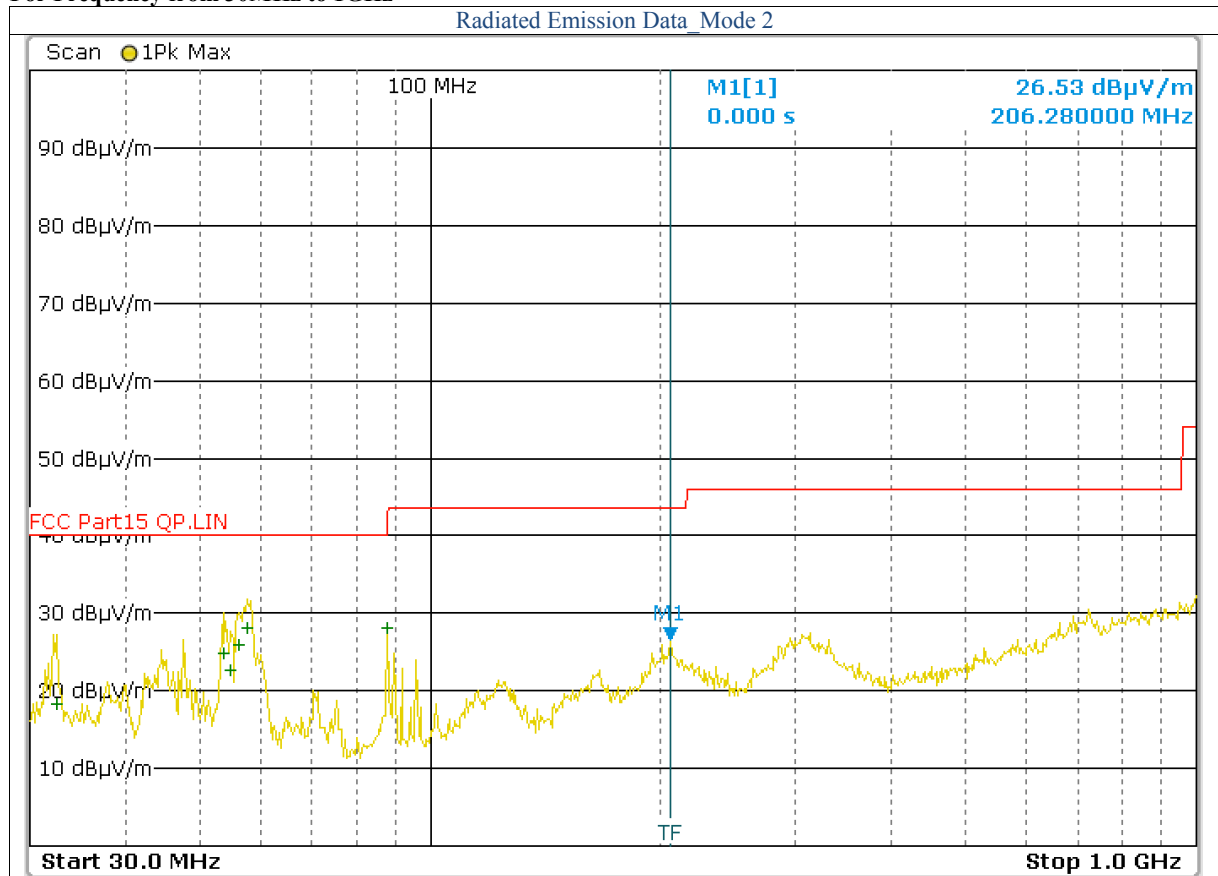

Frequency (MHz)	Read Level (dBuV)	Factor (dB)	Emission (dBuV/m)	Horiz./Vert.	Limit (dBuV/m)	Margin (dB)
32.600	8.34	12.06	20.4	Horiz./	40.0	-19.60
53.600	13.94	10.66	24.6	Horiz./	40.0	-15.40
54.880	11.96	10.66	22.62	Horiz./	40.0	-17.38
56.290	15.29	10.66	25.95	Horiz./	40.0	-14.05
57.760	17.47	10.66	28.13	Horiz./	40.0	-11.87
87.800	20.72	7.43	28.15	Horiz./	40.0	-11.85

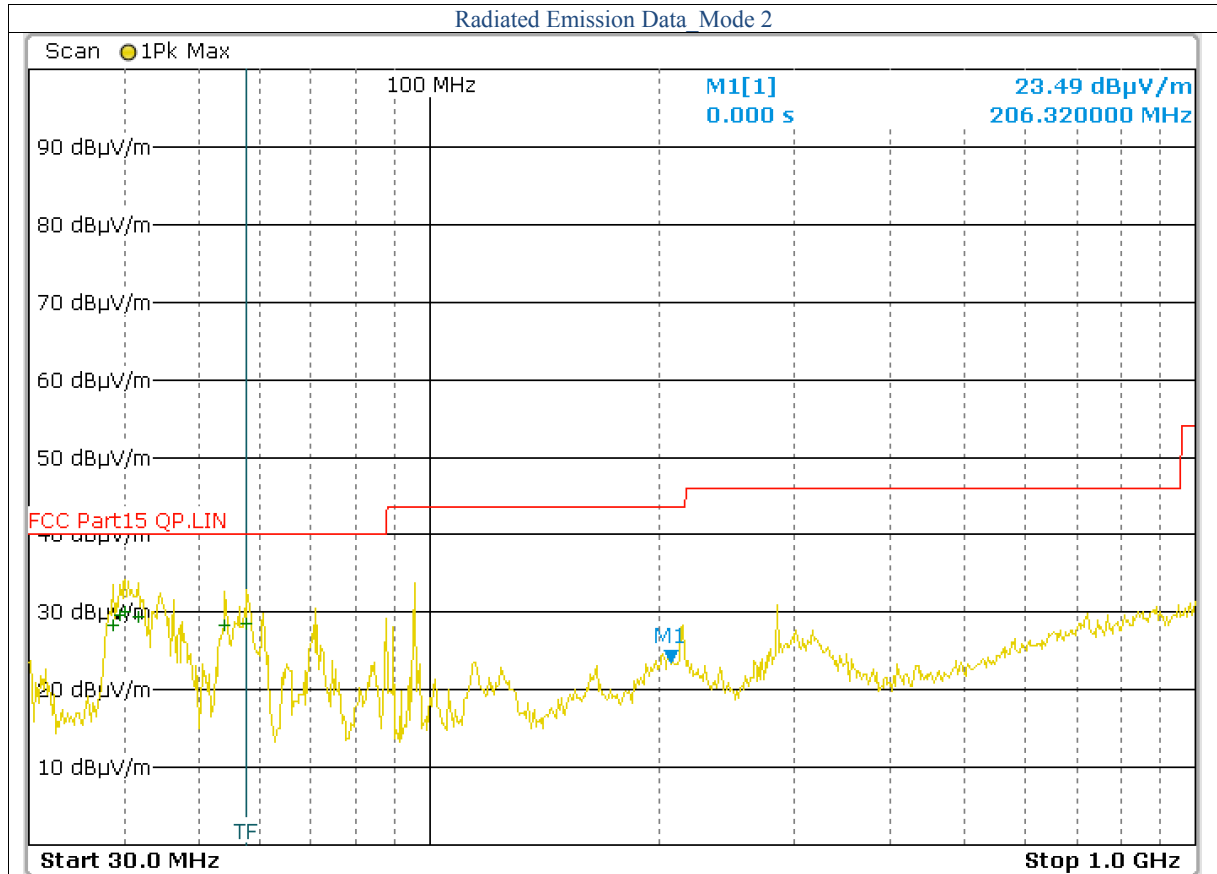

Frequency (MHz)	Read Level (dBuV)	Factor (dB)	Emission (dBuV/m)	Horiz./Vert.	Limit (dBuV/m)	Margin (dB)
38.720	16.65	11.78	28.43	Vert.	40.0	-11.57
39.640	17.79	11.78	29.57	Vert.	40.0	-10.43
40.120	18.57	11.54	30.11	Vert.	40.0	-9.89
41.640	17.93	11.54	29.47	Vert.	40.0	-10.53
54.000	18.71	10.66	29.37	Vert.	40.0	-10.63
57.800	17.98	10.66	28.64	Vert.	40.0	-11.36

- Note:**
- (1) All Readings below 1GHz are Quasi-Peak, above are performed with peak and/or average measurements as necessary.
 - (2) "N/A" remark, if no specific emissions from the EUT are recorded (ie: margin>20dB from the applicable limit) and considered that's already beyond the background noise floor.
 - (3) Emission Level = Reading Level + Probe Factor + Cable Loss.

6. Photo of Testing

6.1 Emission test view

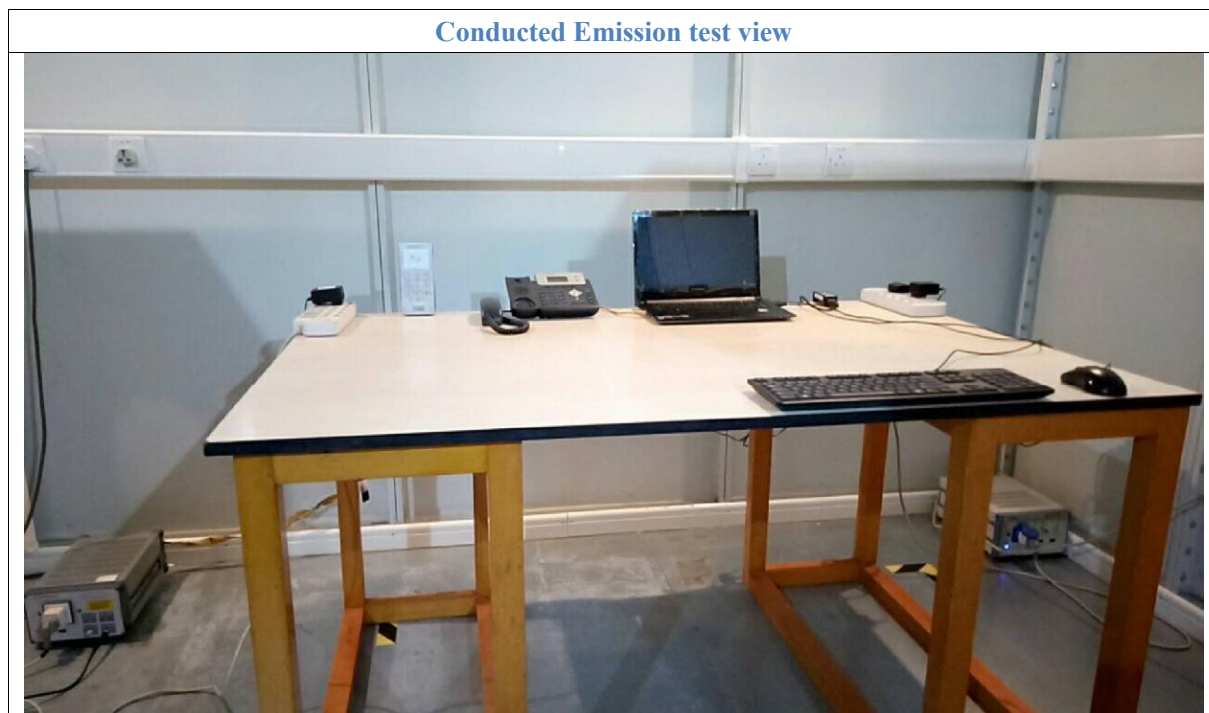

Radiated Emission test view (Below 1GHz)

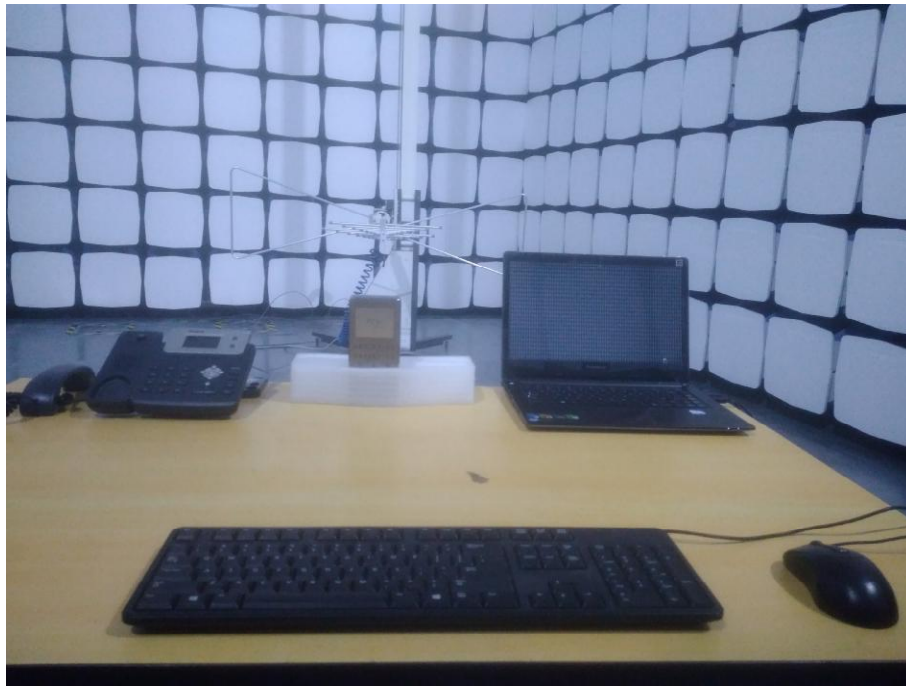

Radiated Emission test view (Above 1GHz)



6.2 Photograph - EUT



EUT side view



EUT Bottom view

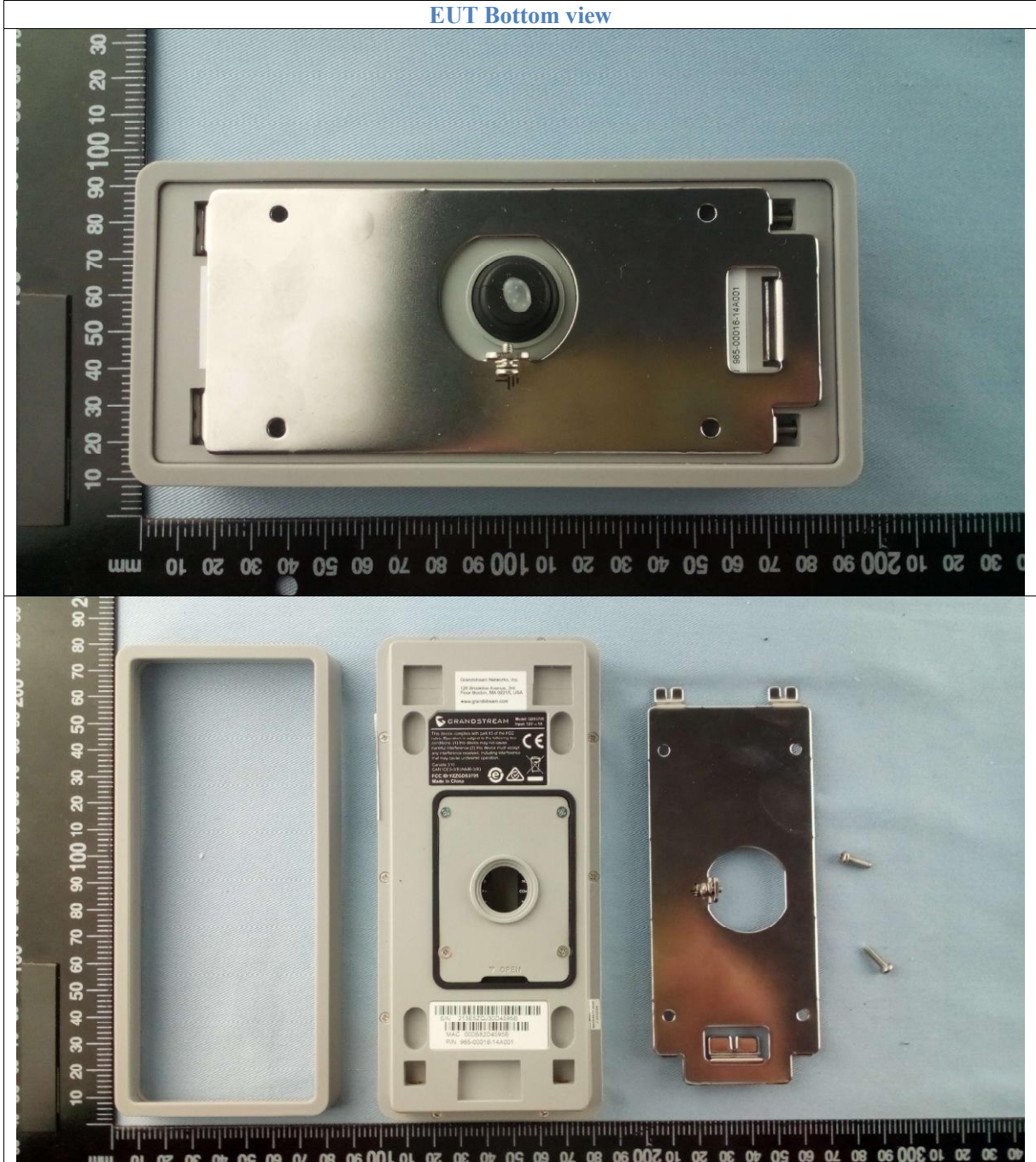



EUT side view



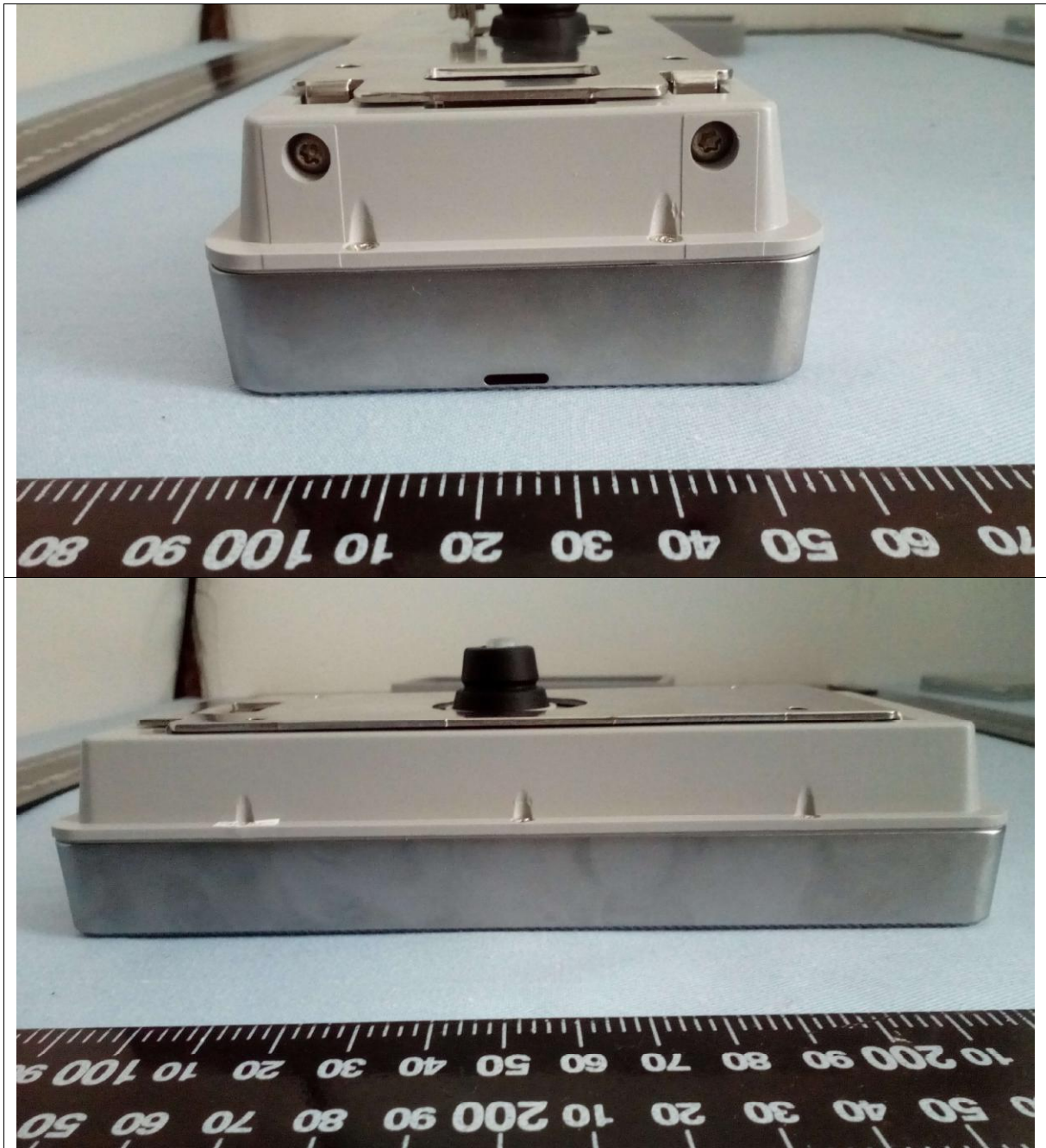

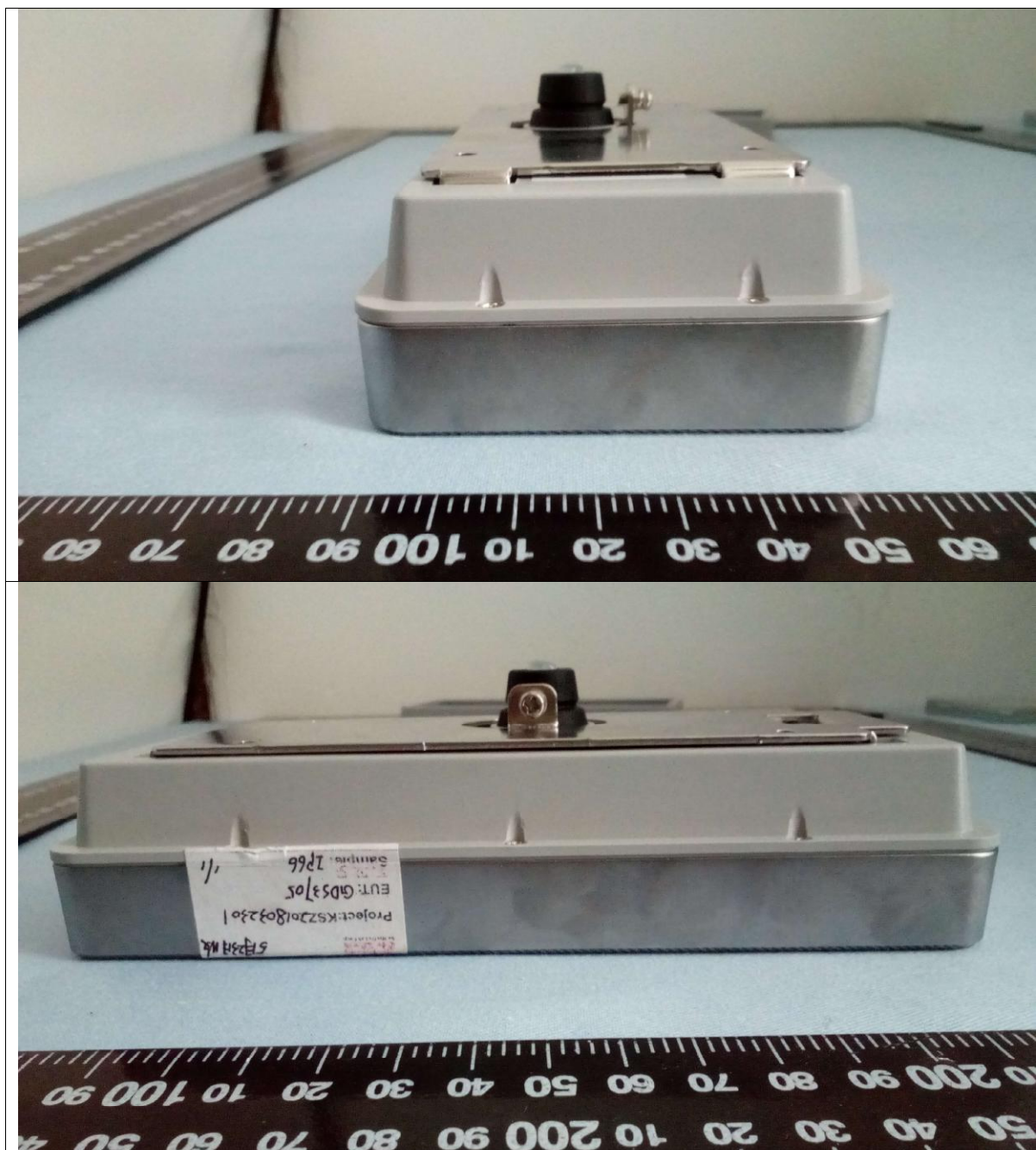

EUT inside whole view

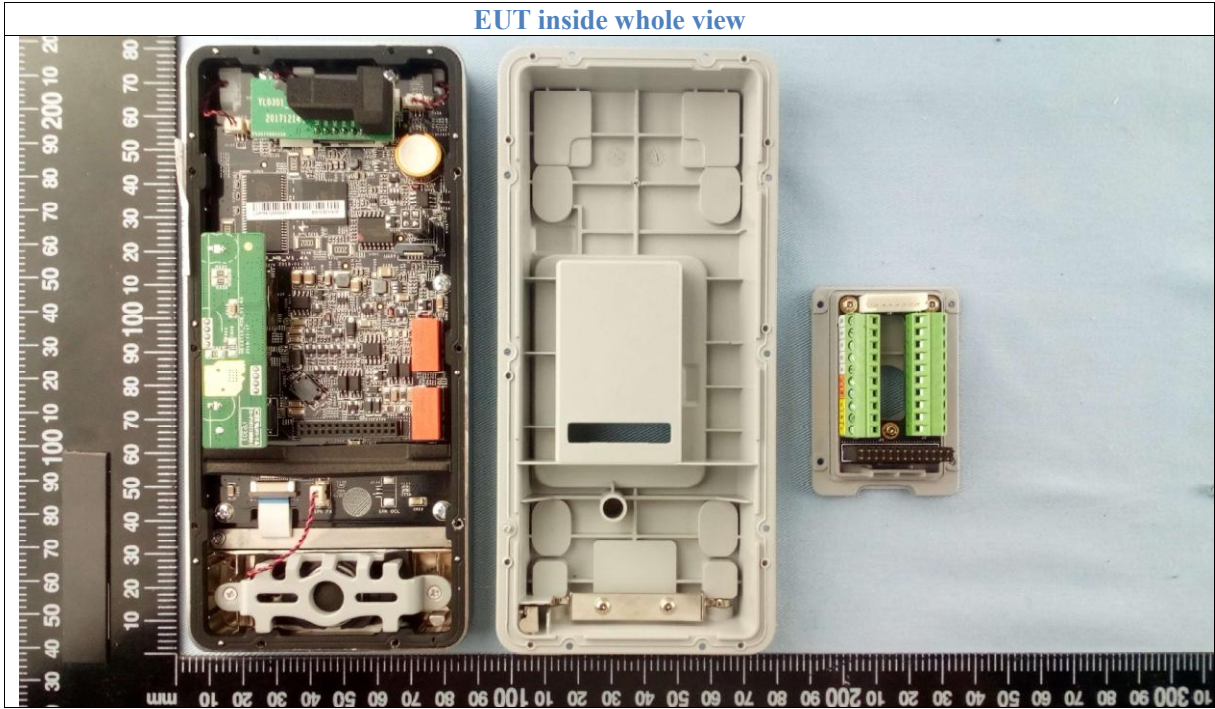

EUT Component side view

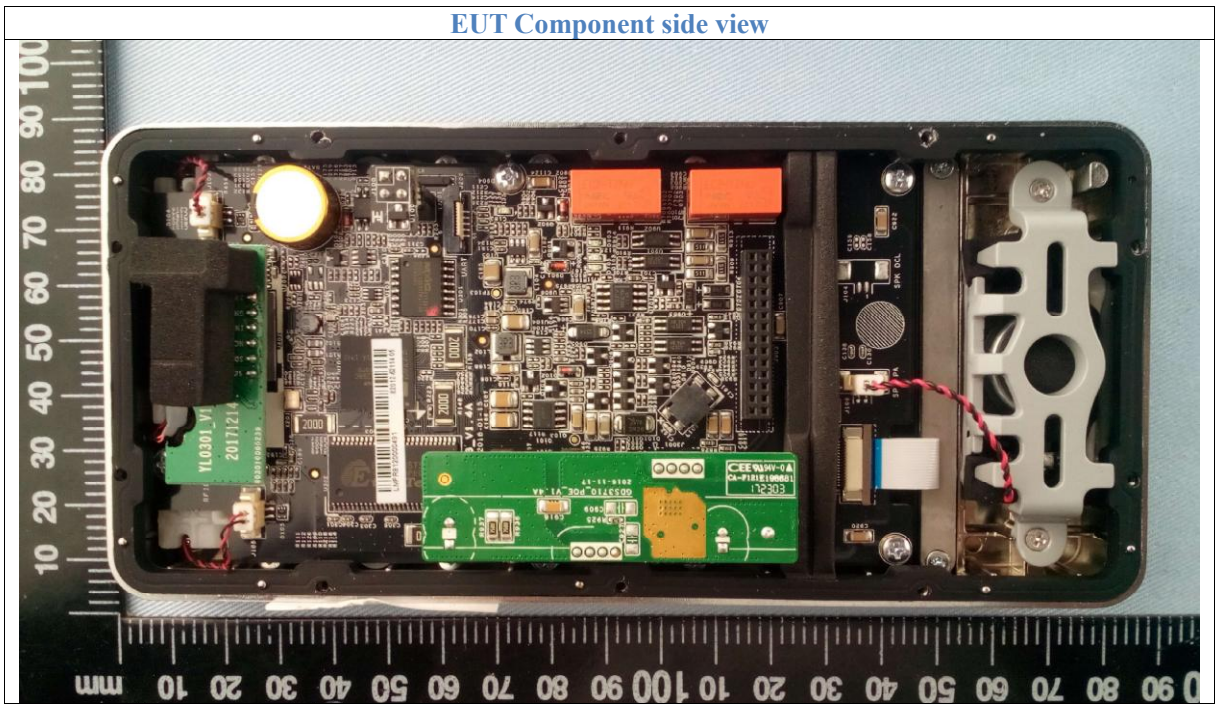

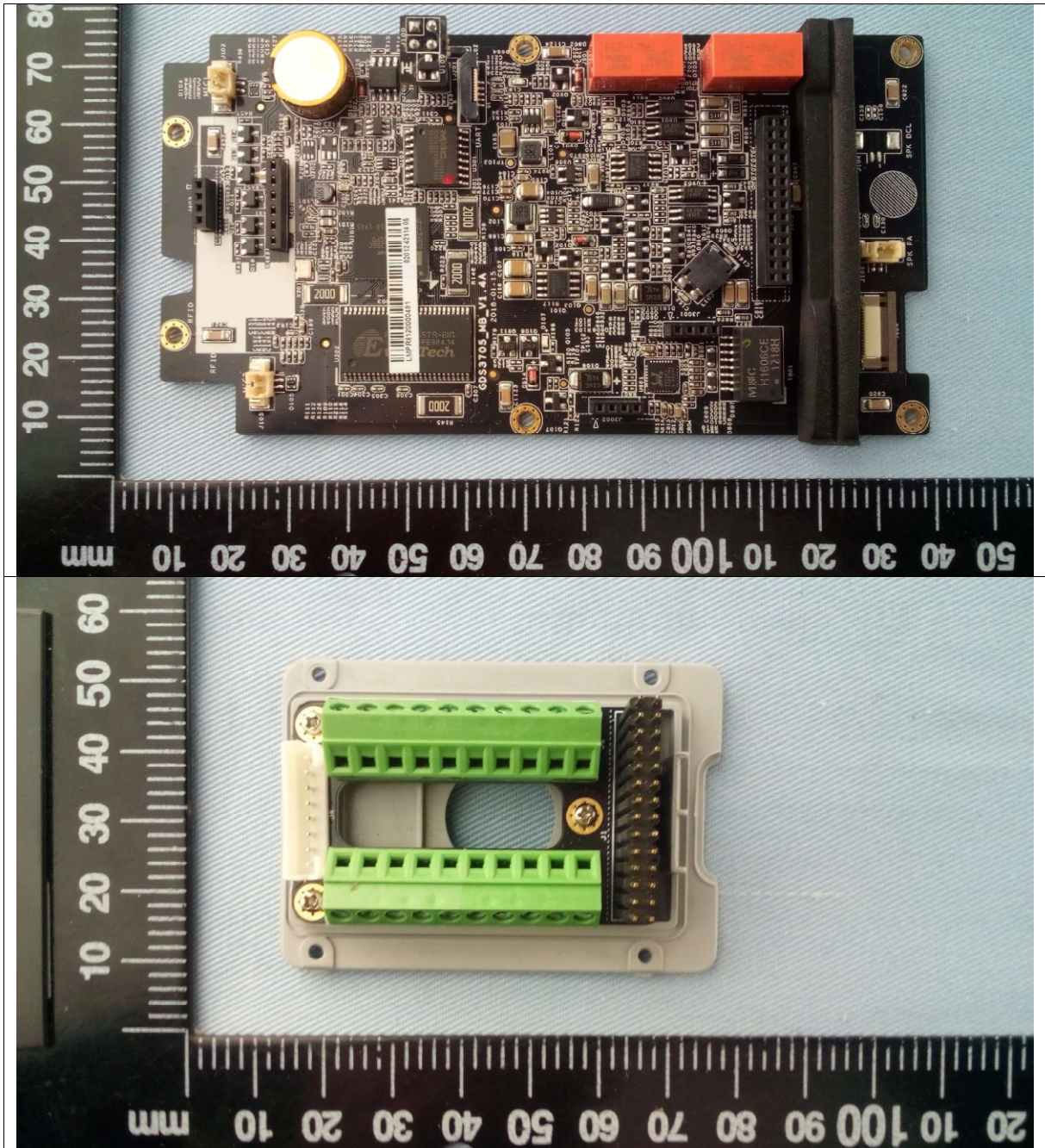

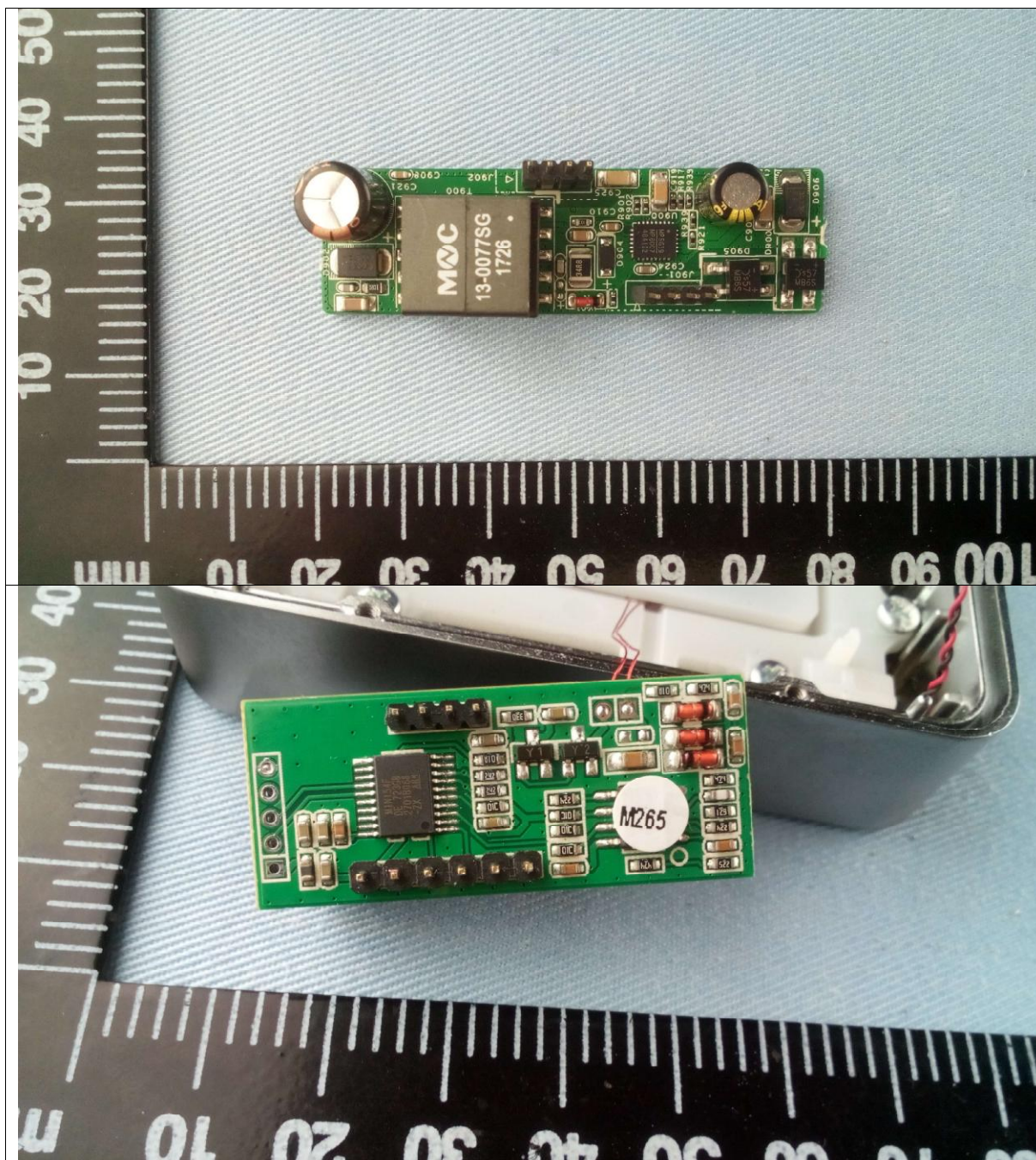

EUT Layout side view

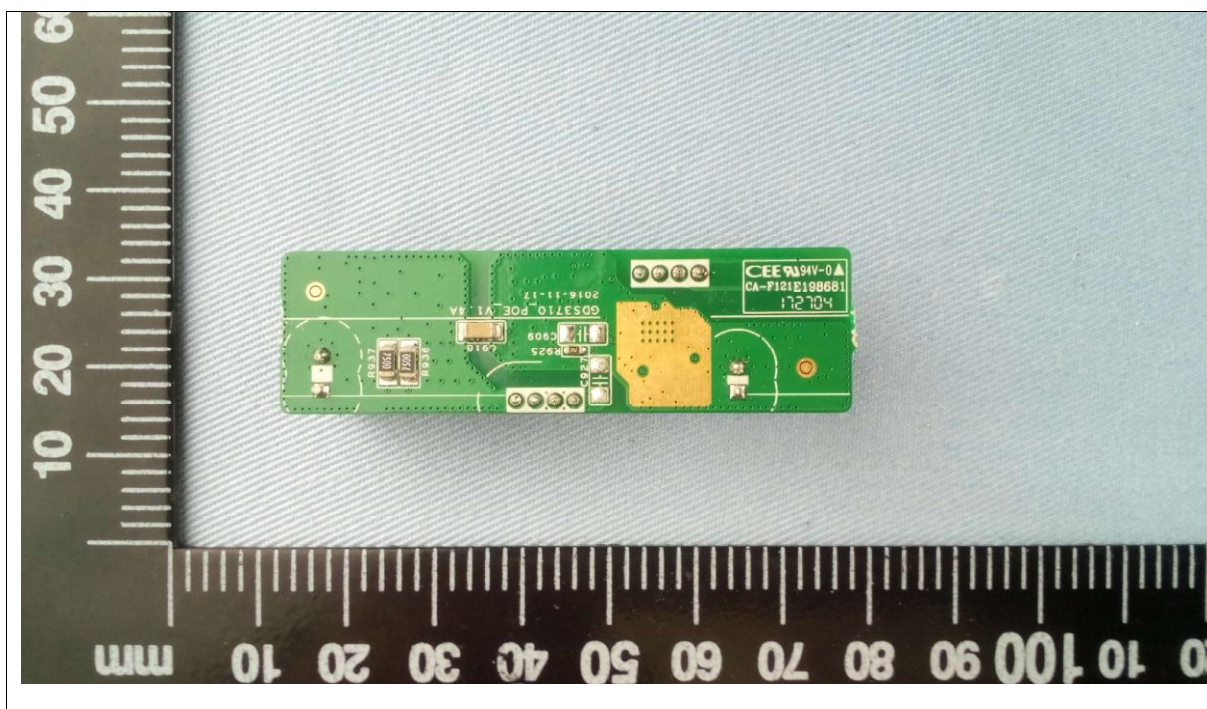
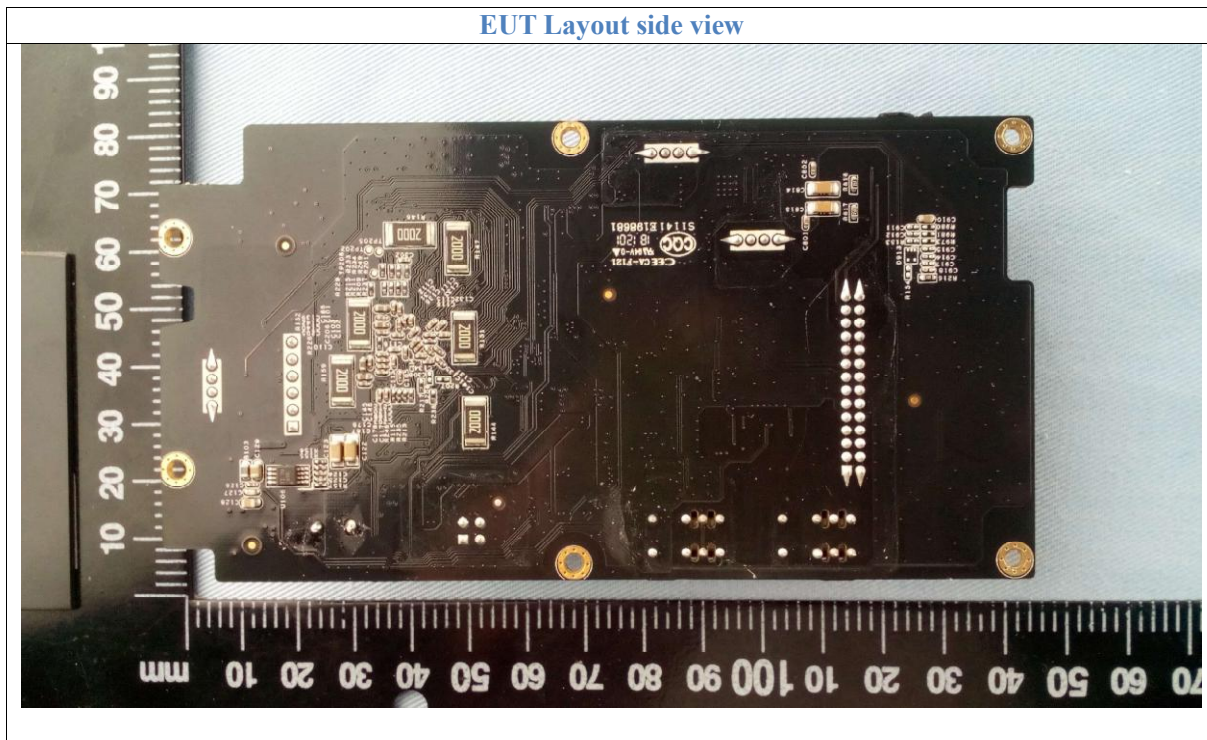

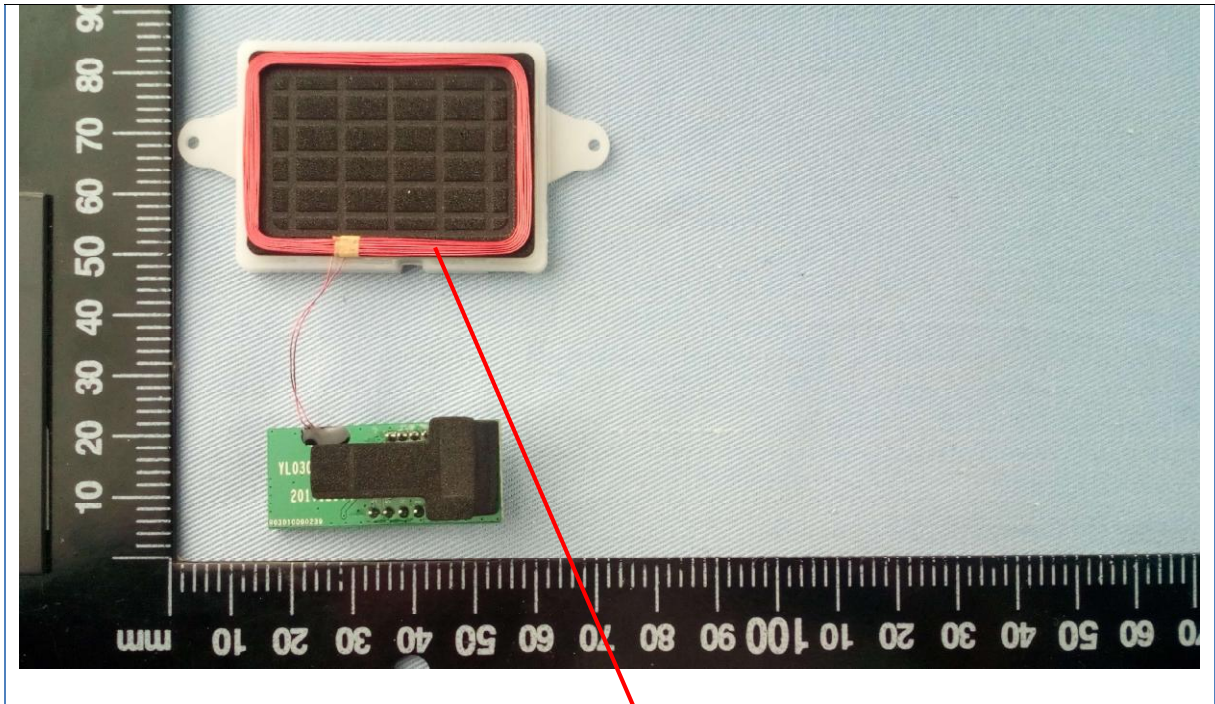

Antenna

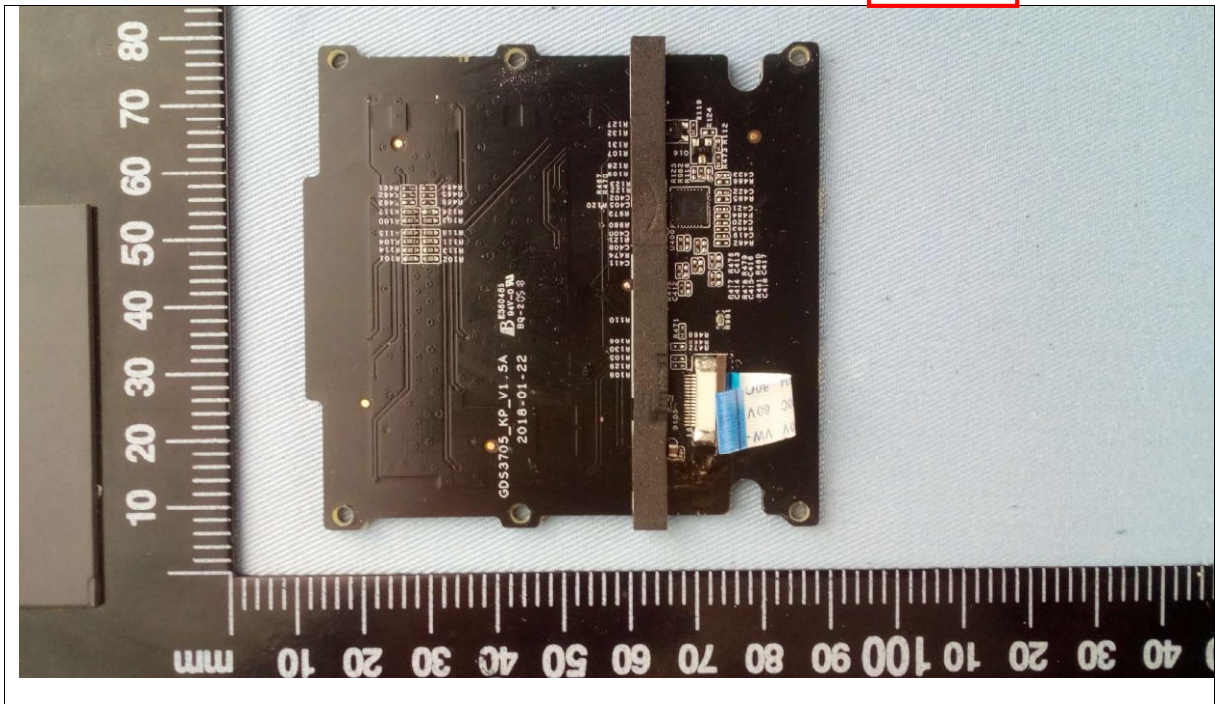

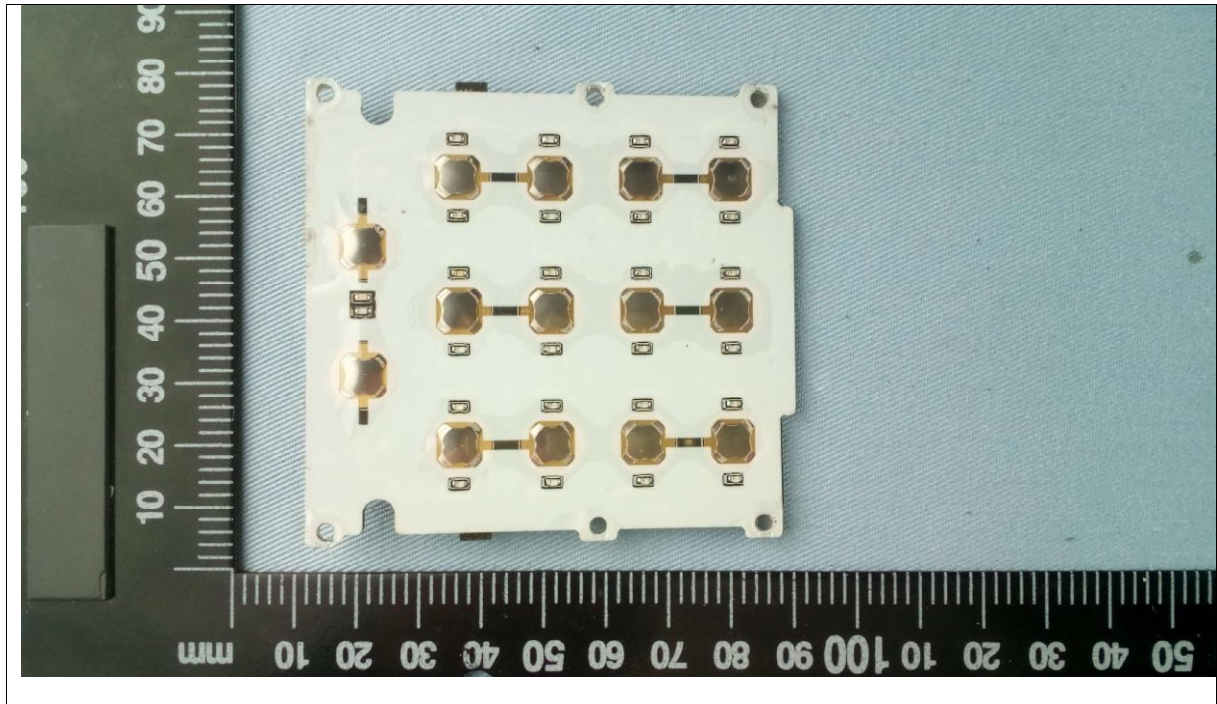

7. FCC ID Label

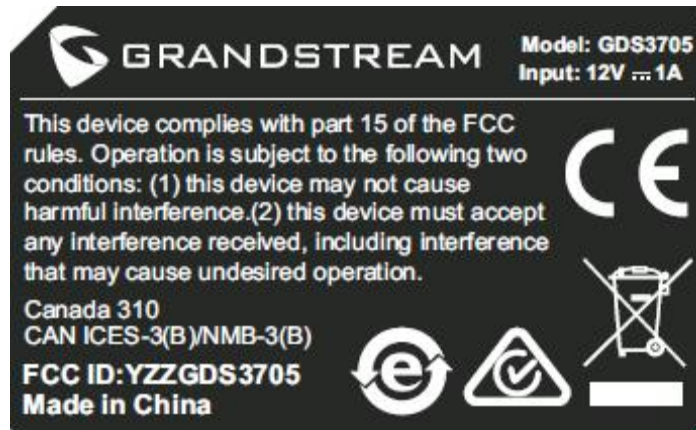

The following note shall be conspicuously placed in the user manual: **“Operation is subject to the following two conditions: (1) this device may not cause interference, and (2) this device must accept any interference, including interference that may cause undesired operation of this device.”**

The Label must not be a stick-on paper label. The Label on these products must be permanently affixed to the product and readily visible at the time of purchase and must last the expected lifetime of the equipment not be readily detachable.



8. Test Equipment

The following test equipments were used during the radiated & conducted emission test:

Equipment/ Facilities	Manufacturer	Model #	Serial No.	Cal/Char Date	Due Date
Turntable	Innco systems GmbH	CT-0801	N/A	NCR	NCR
Antenna Tower	Innco systems GmbH	MA-4640-XP-ET	N/A	NCR	NCR
Controller	Innco systems GmbH	CO3000	955/38850716L	NCR	NCR
EMI Test Receiver	Rohde & Schwarz	ESR7	101091	Dec.6, 2016	Dec.6, 2018
Spectrum Analyzer	Rohde & Schwarz	FSP40	100273	Dec.14, 2017	Dec.14, 2019
Loop Antenna	Rohde & Schwarz	HFH2-Z2	100022	Feb.21, 2018	Feb.21, 2020
AMN	Rohde & Schwarz	ESH3-Z5	100197	Dec.25, 2017	Dec.25, 2019
AMN	CYBERTEK	EM5040A	E115040054	Sep.6, 2016	Sep.6, 2018
KMO Shielded Room	KMO	KMO-001	N/A	NCR	NCR
3m Anechoic Chamber	KMO	KMO-3AC	N/A	Dec.23, 2017	Dec.23, 2019