

### 7.7.4. Test Setup

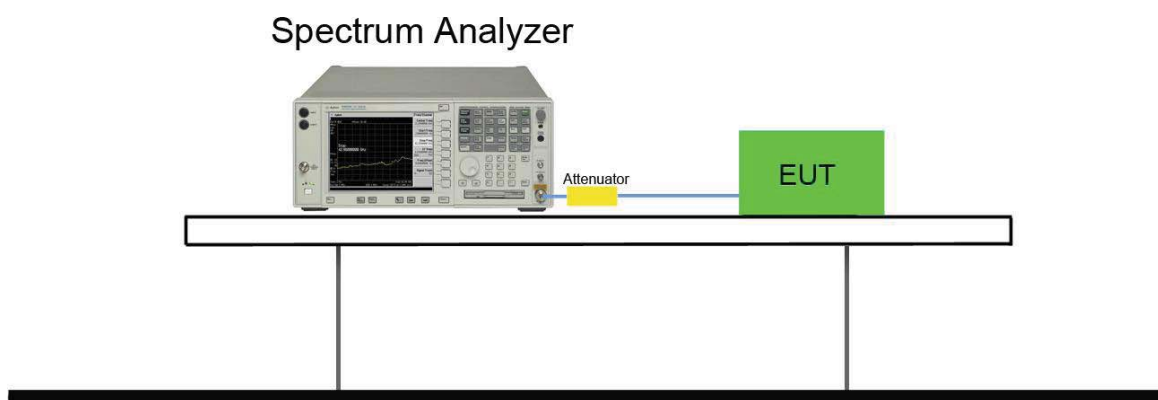

### 7.7.5. Test Result

Test Mode	Channel No.	Frequency (MHz)	Limit	Result
DH5	00	2402	20dBc	Pass
DH5	78	2480	20dBc	Pass
2DH5	00	2402	20dBc	Pass
2DH5	78	2480	20dBc	Pass
3DH5	00	2402	20dBc	Pass
3DH5	78	2480	20dBc	Pass

#### DH5 Band-edge Compliance

##### Channel 00 (2402MHz)

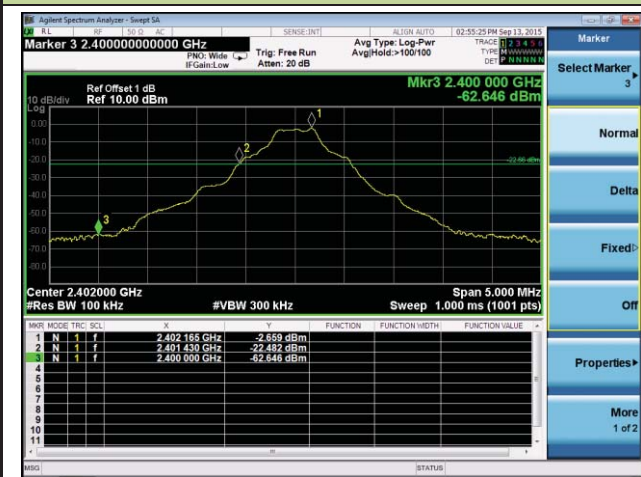

##### Channel 78 (2480MHz)

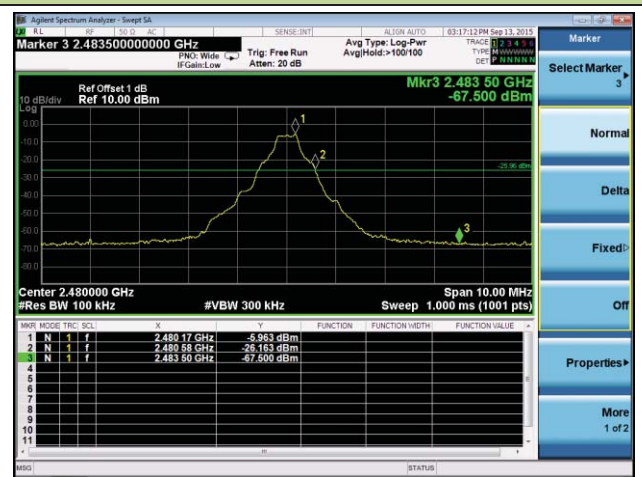

#### 2DH5 Band-edge Compliance

##### Channel 00 (2402MHz)



##### Channel 78 (2480MHz)

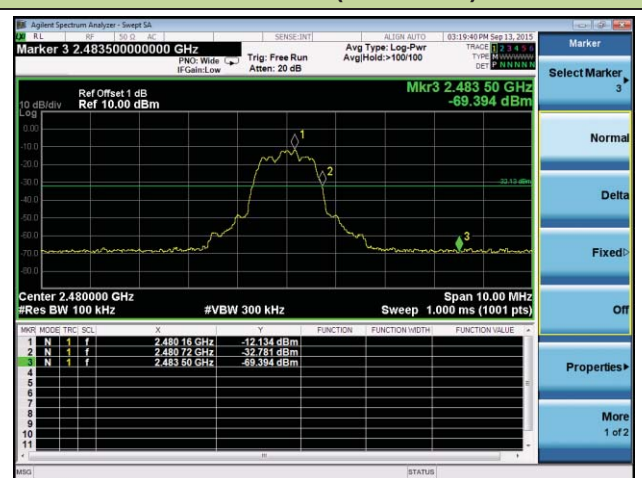

### 3DH5 Band-edge Compliance

#### Channel 00 (2402MHz)

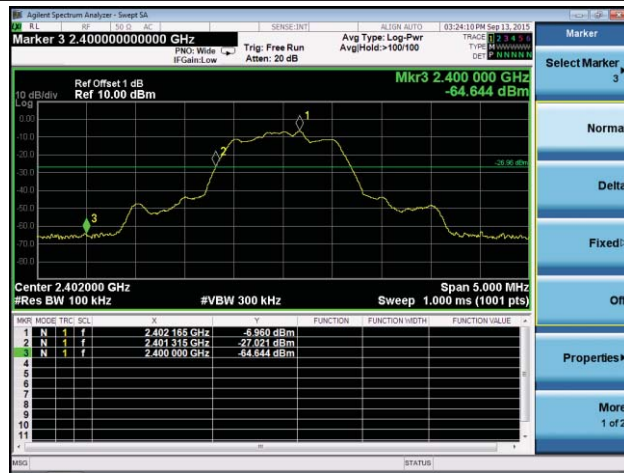

#### Channel 78 (2480MHz)

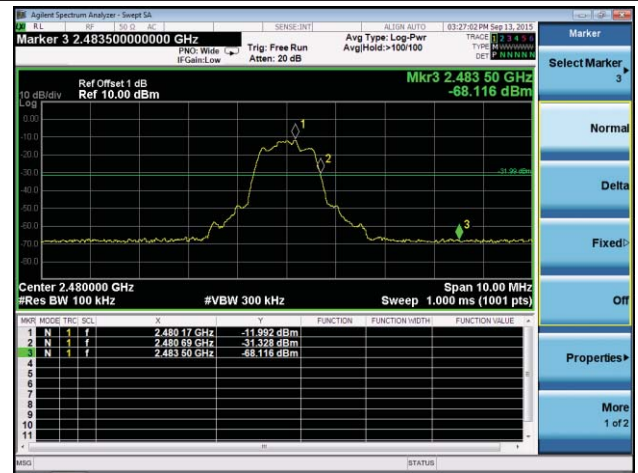

### DH5 Operation Frequency Range of 20dB Bandwidth within Hopping Mode

#### Channel 00 (2402MHz)

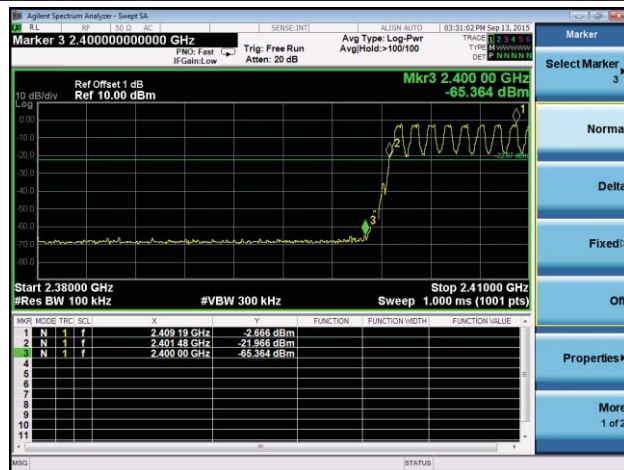

#### Channel 78 (2480MHz)

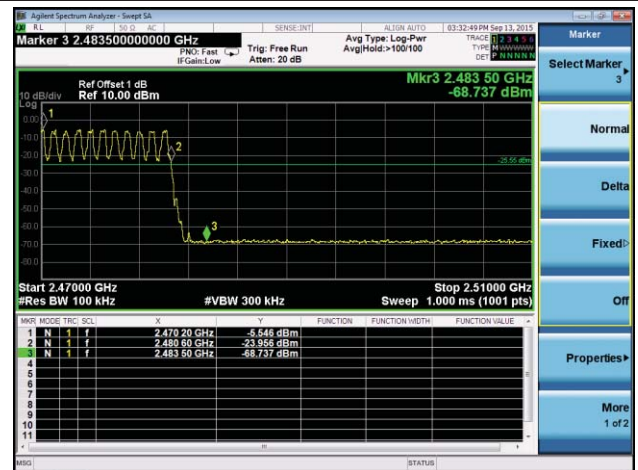

### 2DH5 Operation Frequency Range of 20dB Bandwidth within Hopping Mode

#### Channel 00 (2402MHz)

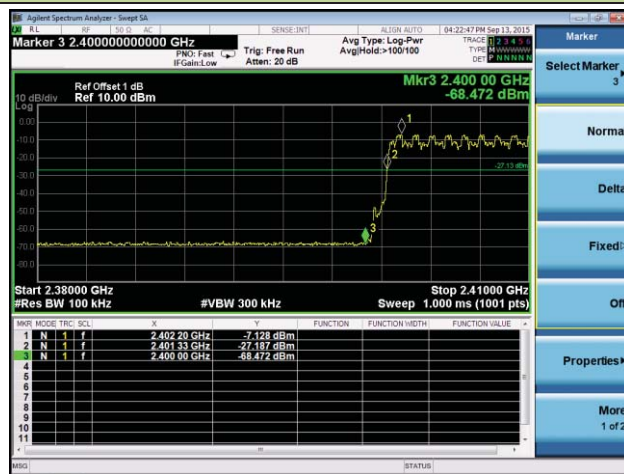

#### Channel 78 (2480MHz)

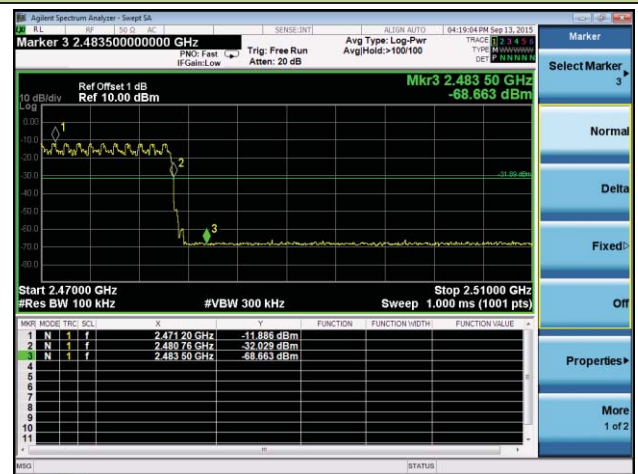

### 3DH5 Operation Frequency Range of 20dB Bandwidth within Hopping Mode

#### Channel 00 (2402MHz)

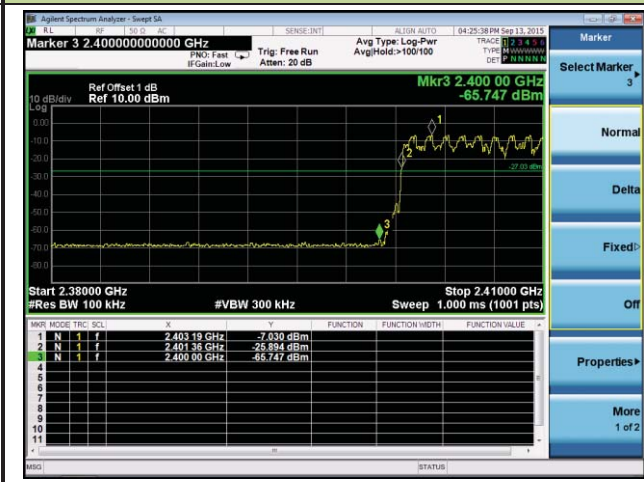

#### Channel 78 (2480MHz)

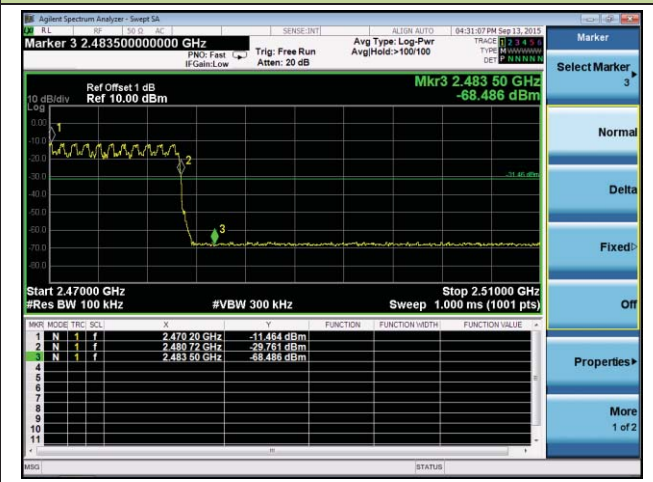

## **7.8. Conducted Spurious Emissions Measurement**

### **7.8.1. Test Limit**

In any 100 kHz bandwidth outside the frequency band in which the spread spectrum or digitally modulated intentional radiator is operating, the radio frequency power that is produced by the intentional radiator shall be at least 20 dB below that in the 100 kHz bandwidth within the band that contains the highest level of the desired power, based on either an RF conducted or a radiated measurement, provided the transmitter demonstrates compliance with the peak conducted or a radiated measurement, provided the transmitter demonstrates compliance with the peak conducted power limits. If the transmitter complies with the conducted power limits based on the use of RMS averaging over a time interval, the attenuation required under this paragraph shall be 30 dB instead of 20 dB.

### **7.8.2. Test Procedure Used**

ANSI C63.10-2013 - Section 7.8.8

### **7.8.3. Test Setting**

1. Span = wide enough to capture the peak level of the in-band emission and all spurious emissions (e.g., harmonics) from the lowest frequency generated in the EUT up through the 10<sup>th</sup> harmonic. Typically, several plots are required to cover this entire span.
2. RBW = 100 KHz
3. VBW  $\geq$  RBW
4. Detector = peak
5. Sweep time = auto couple
6. Trace mode = max hold
7. Trace was allowed to stabilize

Set the marker on the peak of any spurious emission recorded. The level displayed must comply with the limit specified in this section.

### 7.8.4. Test Setup

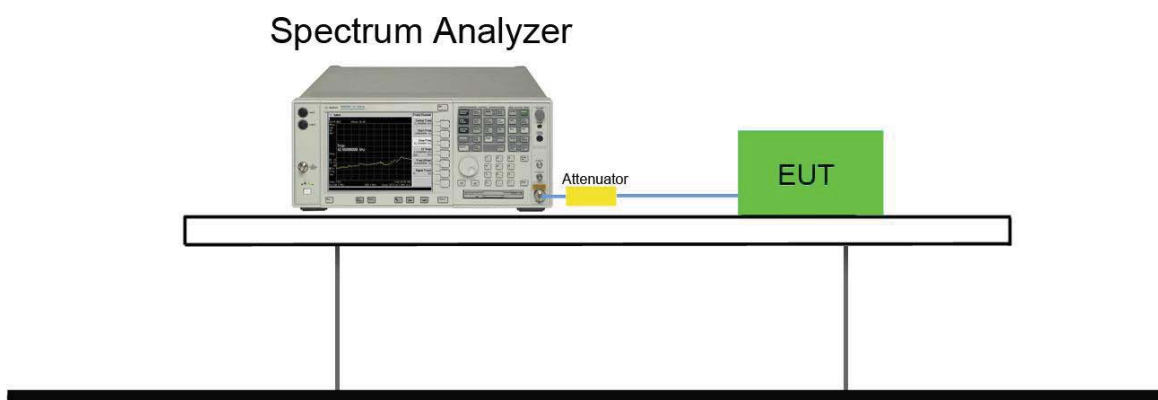

### 7.8.5. Test Result

Test Mode	Channel No.	Frequency (MHz)	Limit (MHz)	Result
DH5	00	2402	20dBc	Pass
DH5	39	2441	20dBc	Pass
DH5	78	2480	20dBc	Pass
2DH5	00	2402	20dBc	Pass
2DH5	39	2441	20dBc	Pass
2DH5	78	2480	20dBc	Pass
3DH5	00	2402	20dBc	Pass
3DH5	39	2441	20dBc	Pass
3DH5	78	2480	20dBc	Pass

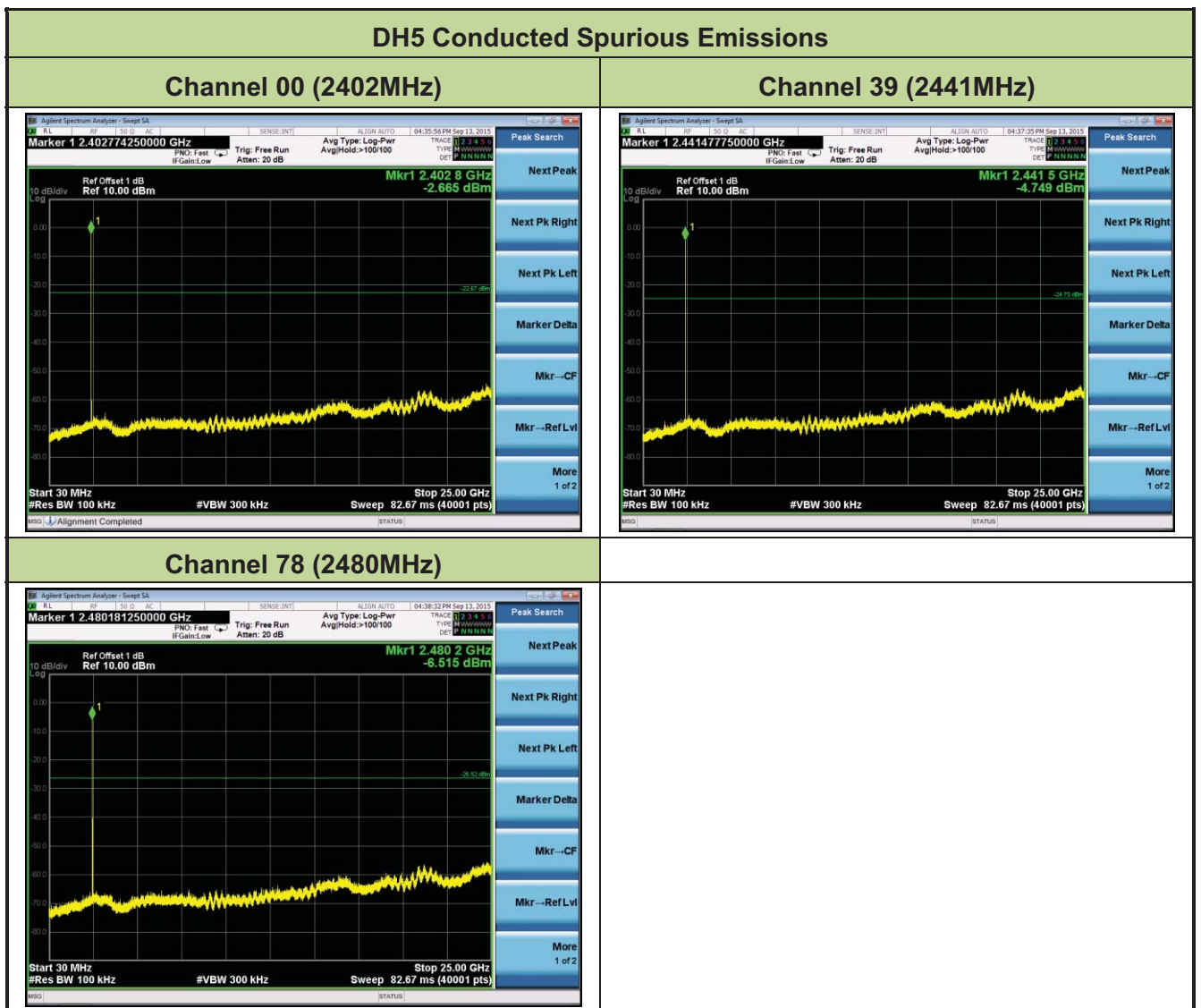

### 2DH5 Conducted Spurious Emissions

#### Channel 00 (2402MHz)



#### Channel 39 (2441MHz)



#### Channel 78 (2480MHz)

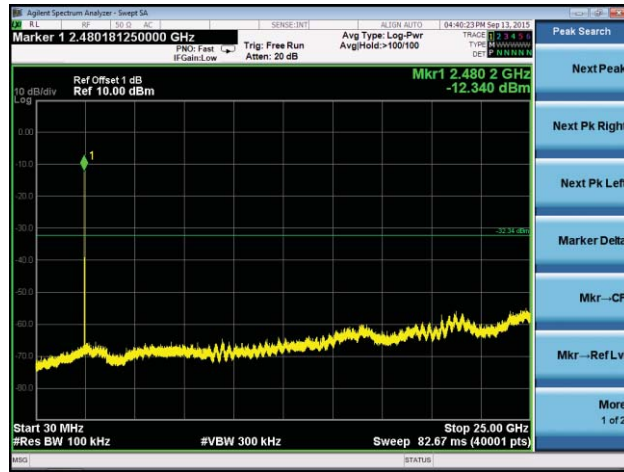



### 3DH5 Conducted Spurious Emissions

**Channel 00 (2402MHz)**



**Channel 39 (2441MHz)**



**Channel 78 (2480MHz)**



## 7.9. Radiated Spurious Emission Measurement

### 7.9.1. Test Limit

All out of band emissions appearing in a restricted band as specified in Section 15.205 of the Title 47 CFR must not exceed the limits shown in Table per Section 15.209.

FCC Part 15 Subpart C Paragraph 15.209		
Frequency [MHz]	Field Strength [V/m]	Measured Distance [Meters]
0.009 - 0.490	2400/F (kHz)	300
0.490 - 1.705	24000/F (kHz)	30
1.705 – 30	30	30
30 – 88	100	3
88 – 216	150	3
216 – 960	200	3
Above 960	500	3

### 7.9.2. Test Procedure Used

ANSI C63.10-2013 - Section 11.12.1

### 7.9.3. Test Setting

#### Peak Field Strength Measurements

1. Analyzer center frequency was set to the frequency of the radiated spurious emission of interest
2. RBW = as specified in Table 1
3. VBW = 3 \* RBW
4. Detector = peak
5. Sweep time = auto couple
6. Trace mode = max hold
7. Trace was allowed to stabilize

**Table 1 - RBW as a function of frequency**

Frequency	RBW
9 ~ 150 kHz	200 ~ 300 Hz
0.15 ~ 30 MHz	9 ~ 10 kHz
30 ~ 1000 MHz	100 ~ 120 kHz
> 1000 MHz	1 MHz

**Average Field Strength Measurements**

1. Analyzer center frequency was set to the frequency of the radiated spurious emission of interest
2. RBW = 1MHz
3. VBW  $\geq$  1/T
4. De As an alternative, the instrument may be set to linear detector mode. Ensure that video filtering is applied in linear voltage domain (rather than in a log or dB domain). Some instruments require linear display mode in order to accomplish this. Others have a setting for Average-VBW Type, which can be set to "Voltage" regardless of the display mode
5. Detector = Peak
6. Sweep time = auto
7. Trace mode = max hold
8. Allow max hold to run for at least 50 times (1/duty cycle) traces

### 7.9.4. Test Setup

#### 9kHz ~ 30MHz Test Setup:

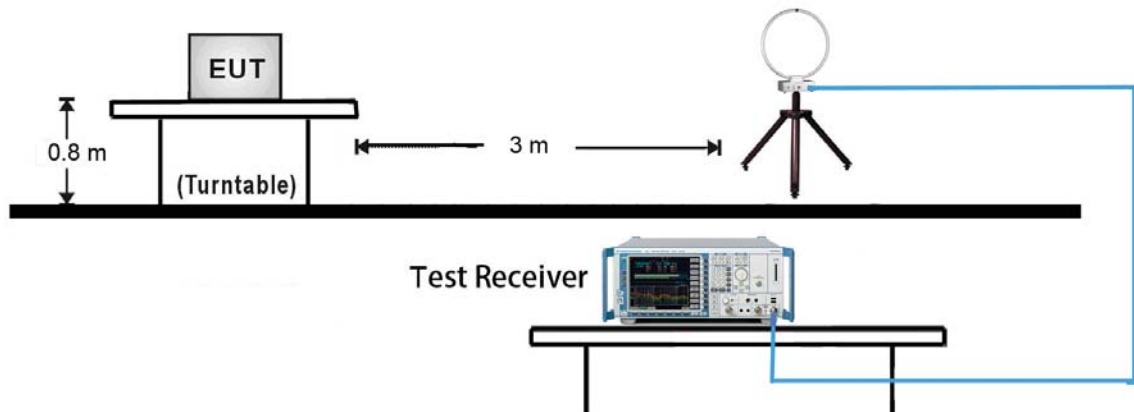

#### 30MHz ~ 1GHz Test Setup:

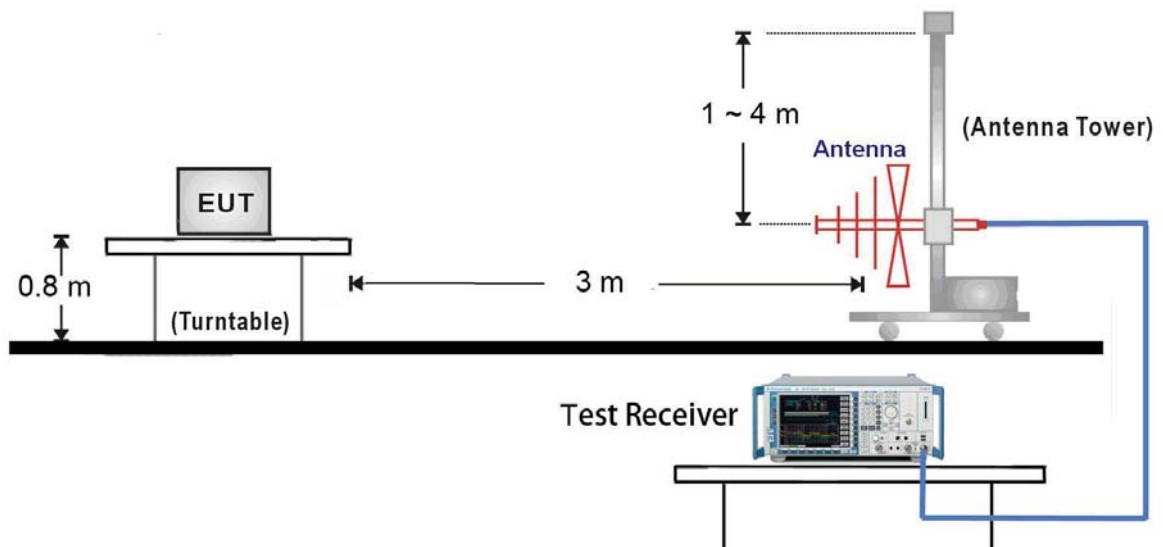

1GHz ~ 18GHz Test Setup:

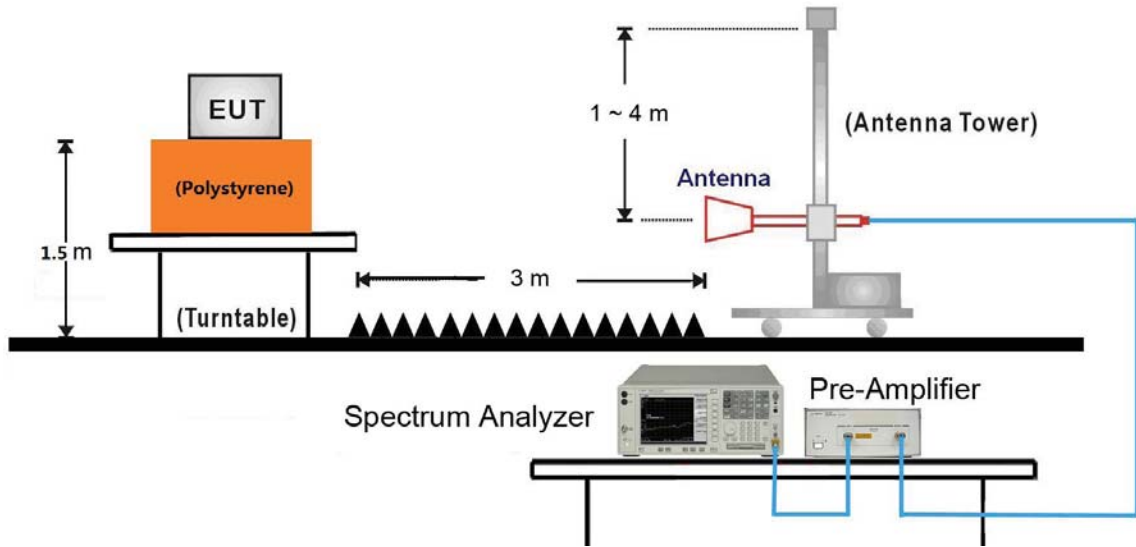

18GHz ~ 25GHz Test Setup:

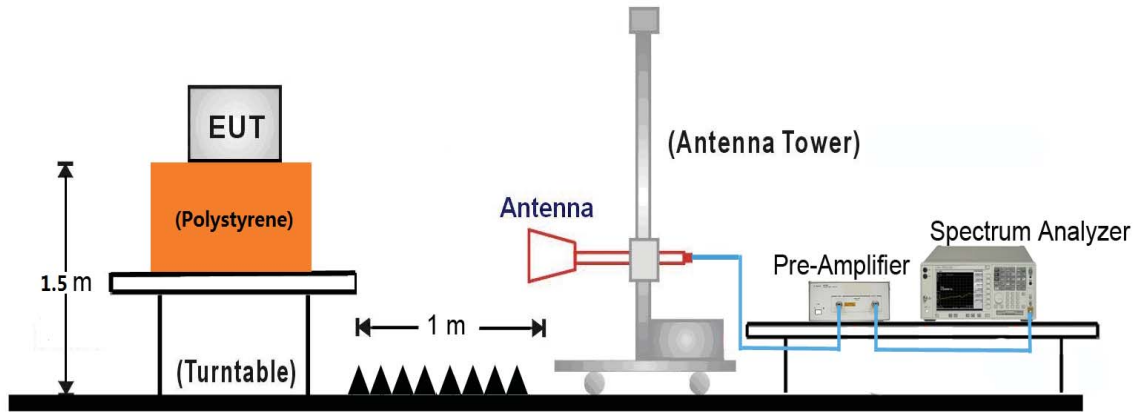

**7.9.5. Test Result**

Test Mode:	DH5	Test Site:	AC1
Test Channel:	00	Test Engineer:	Roy Cheng
Remark:	1. Average measurement was not performed if peak level lower than average limit. 2. Other frequency was 20dB below limit line within 1-18GHz, there is not show in the report.		

Mark	Frequency (MHz)	Reading Level (dB $\mu$ V)	Factor (dB)	Measure Level (dB $\mu$ V/m)	Limit (dB $\mu$ V/m)	Margin (dB)	Detector	Polarization
*	3524.0	38.7	-1.0	37.7	74.0	-36.3	Peak	Horizontal
*	4426.0	36.6	1.5	38.1	74.0	-35.9	Peak	Horizontal
	4804.0	35.7	2.7	38.4	74.0	-35.6	Peak	Horizontal
	5382.0	35.4	3.0	38.4	74.0	-35.6	Peak	Horizontal
*	3525.0	38.9	-1.0	37.9	74.0	-36.1	Peak	Vertical
*	4477.0	36.6	1.6	38.2	74.0	-35.8	Peak	Vertical
	4804.0	36.0	2.7	38.7	74.0	-35.3	Peak	Vertical
	5389.0	35.8	3.1	38.9	74.0	-35.1	Peak	Vertical

Note 1: "\*" is not in restricted band, its limit is 20dBc of the fundamental emission level (91.8dB $\mu$ V/m) or 15.209 which is higher.

Note 2: Measure Level (dB $\mu$ V/m) = Reading Level (dB $\mu$ V) + Factor (dB)

Factor (dB) = Cable Loss (dB) + Antenna Factor (dB/m) - Pre\_Amplifier Gain (dB)

Test Mode:	DH5	Test Site:	AC1
Test Channel:	39	Test Engineer:	Roy Cheng
Remark:	1. Average measurement was not performed if peak level lower than average limit. 2. Other frequency was 20dB below limit line within 1-18GHz, there is not show in the report.		

Mark	Frequency (MHz)	Reading Level (dBμV)	Factor (dB)	Measure Level (dBμV/m)	Limit (dBμV/m)	Margin (dB)	Detector	Polarization
*	3452.0	37.7	-1.4	36.3	74.0	-37.7	Peak	Horizontal
*	4485.0	35.9	1.6	37.5	74.0	-36.5	Peak	Horizontal
	4773.0	37.3	2.6	39.9	74.0	-34.1	Peak	Horizontal
	5394.0	36.1	3.1	39.2	74.0	-34.8	Peak	Horizontal
*	3561.0	38.0	-0.8	37.2	74.0	-36.8	Peak	Vertical
*	4482.0	36.2	1.6	37.8	74.0	-36.2	Peak	Vertical
	4925.0	35.7	2.8	38.5	74.0	-35.5	Peak	Vertical
	5399.0	35.3	3.1	38.4	74.0	-35.6	Peak	Vertical

Note 1: "\*" is not in restricted band, its limit is 20dBc of the fundamental emission level (91.2dBμV/m) or 15.209 which is higher.

Note 2: Measure Level (dBμV/m) = Reading Level (dBμV) + Factor (dB)

Factor (dB) = Cable Loss (dB) + Antenna Factor (dB/m) - Pre\_Amplifier Gain (dB)

Test Mode:	DH5	Test Site:	AC1
Test Channel:	78	Test Engineer:	Roy Cheng
Remark:	1. Average measurement was not performed if peak level lower than average limit. 2. Other frequency was 20dB below limit line within 1-18GHz, there is not show in the report.		

Mark	Frequency (MHz)	Reading Level (dBμV)	Factor (dB)	Measure Level (dBμV/m)	Limit (dBμV/m)	Margin (dB)	Detector	Polarization
*	3535.0	38.5	-1.0	37.5	74.0	-36.5	Peak	Horizontal
*	4422.0	36.3	1.4	37.7	74.0	-36.3	Peak	Horizontal
	4960.0	35.7	2.9	38.6	74.0	-35.4	Peak	Horizontal
	7440.0	34.9	8.0	42.9	74.0	-31.1	Peak	Horizontal
*	3553.0	38.2	-0.9	37.3	74.0	-36.7	Peak	Vertical
*	4475.0	36.6	1.6	38.2	74.0	-35.8	Peak	Vertical
	4960.0	36.1	2.9	39.0	74.0	-35.0	Peak	Vertical
	7440.0	35.2	8.0	43.2	74.0	-30.8	Peak	Vertical

Note 1: "\*" is not in restricted band, its limit is 20dBc of the fundamental emission level (90.7BμV/m) or 15.209 which is higher.

Note 2: Measure Level (dBμV/m) = Reading Level (dBμV) + Factor (dB)

Factor (dB) = Cable Loss (dB) + Antenna Factor (dB/m) - Pre\_Amplifier Gain (dB)



Test Mode:	2DH5	Test Site:	AC1
Test Channel:	00	Test Engineer:	Roy Cheng
Remark:	1. Average measurement was not performed if peak level lower than average limit. 2. Other frequency was 20dB below limit line within 1-18GHz, there is not show in the report.		

Mark	Frequency (MHz)	Reading Level (dBμV)	Factor (dB)	Measure Level (dBμV/m)	Limit (dBμV/m)	Margin (dB)	Detector	Polarization
*	2447.0	37.8	-3.8	34.0	74.0	-40.0	Peak	Horizontal
*	4416.0	35.8	1.4	37.2	74.0	-36.8	Peak	Horizontal
	4852.0	36.6	2.7	39.3	74.0	-34.7	Peak	Horizontal
	5446.0	34.5	3.4	37.9	74.0	-36.1	Peak	Horizontal
*	3419.0	38.0	-1.6	36.4	74.0	-37.6	Peak	Vertical
*	4456.0	36.0	1.5	37.5	74.0	-36.5	Peak	Vertical
	4891.0	35.8	2.7	38.5	74.0	-35.5	Peak	Vertical
	7451.0	35.4	8.0	43.4	74.0	-30.6	Peak	Vertical

Note 1: "\*" is not in restricted band, its limit is 20dBc of the fundamental emission level (90.1dBμV/m) or 15.209 which is higher.

Note 2: Measure Level (dBμV/m) = Reading Level (dBμV) + Factor (dB)

Factor (dB) = Cable Loss (dB) + Antenna Factor (dB/m) - Pre\_Amplifier Gain (dB)

Test Mode:	2DH5	Test Site:	AC1
Test Channel:	39	Test Engineer:	Roy Cheng
Remark:	1. Average measurement was not performed if peak level lower than average limit. 2. Other frequency was 20dB below limit line within 1-18GHz, there is not show in the report.		

Mark	Frequency (MHz)	Reading Level (dBμV)	Factor (dB)	Measure Level (dBμV/m)	Limit (dBμV/m)	Margin (dB)	Detector	Polarization
*	3482.0	37.7	-1.2	36.5	74.0	-37.5	Peak	Horizontal
*	4426.0	35.3	1.5	36.8	74.0	-37.2	Peak	Horizontal
	4824.0	35.9	2.7	38.6	74.0	-35.4	Peak	Horizontal
	5381.0	35.3	3.0	38.3	74.0	-35.7	Peak	Horizontal
*	3552.0	38.5	-0.9	37.6	74.0	-36.4	Peak	Vertical
*	4422.0	35.8	1.4	37.2	74.0	-36.8	Peak	Vertical
	4775.0	35.7	2.6	38.3	74.0	-35.7	Peak	Vertical
	5422.0	34.9	3.3	38.2	74.0	-35.8	Peak	Vertical

Note 1: "\*" is not in restricted band, its limit is 20dBc of the fundamental emission level (88.0dBμV/m) or 15.209 which is higher.

Note 2: Measure Level (dBμV/m) = Reading Level (dBμV) + Factor (dB)

Factor (dB) = Cable Loss (dB) + Antenna Factor (dB/m) - Pre\_Amplifier Gain (dB)

Test Mode:	2DH5	Test Site:	AC1
Test Channel:	78	Test Engineer:	Roy Cheng
Remark:	1. Average measurement was not performed if peak level lower than average limit. 2. Other frequency was 20dB below limit line within 1-18GHz, there is not show in the report.		

Mark	Frequency (MHz)	Reading Level (dBμV)	Factor (dB)	Measure Level (dBμV/m)	Limit (dBμV/m)	Margin (dB)	Detector	Polarization
*	3591.0	38.8	-0.7	38.1	74.0	-35.9	Peak	Horizontal
*	4477.0	35.9	1.6	37.5	74.0	-36.5	Peak	Horizontal
	5005.0	35.0	3.0	38.0	74.0	-36.0	Peak	Horizontal
	5359.0	36.3	3.0	39.3	74.0	-34.7	Peak	Horizontal
*	3441.0	38.6	-1.5	37.1	74.0	-36.9	Peak	Vertical
*	4842.0	35.9	2.7	38.6	74.0	-35.4	Peak	Vertical
	5000.0	35.0	3.0	38.0	74.0	-36.0	Peak	Vertical
	5400.0	36.1	3.1	39.2	74.0	-34.8	Peak	Vertical

Note 1: "\*" is not in restricted band, its limit is 20dBc of the fundamental emission level (86.3dBμV/m) or 15.209 which is higher.

Note 2: Measure Level (dBμV/m) = Reading Level (dBμV) + Factor (dB)

Factor (dB) = Cable Loss (dB) + Antenna Factor (dB/m) - Pre\_Amplifier Gain (dB)

Test Mode:	3DH5	Test Site:	AC1
Test Channel:	00	Test Engineer:	Roy Cheng
Remark:	1. Average measurement was not performed if peak level lower than average limit. 2. Other frequency was 20dB below limit line within 1-18GHz, there is not show in the report.		

Mark	Frequency (MHz)	Reading Level (dBμV)	Factor (dB)	Measure Level (dBμV/m)	Limit (dBμV/m)	Margin (dB)	Detector	Polarization
*	3399.0	38.3	-1.7	36.6	74.0	-37.4	Peak	Horizontal
*	4455.0	36.2	1.5	37.7	74.0	-36.3	Peak	Horizontal
	4962.0	35.8	2.9	38.7	74.0	-35.3	Peak	Horizontal
	5377.0	35.9	3.0	38.9	74.0	-35.1	Peak	Horizontal
*	3555.0	38.2	-0.9	37.3	74.0	-36.7	Peak	Vertical
*	4428.0	35.7	1.5	37.2	74.0	-36.8	Peak	Vertical
	4691.0	35.9	2.3	38.2	74.0	-35.8	Peak	Vertical
	5402.0	36.1	3.1	39.2	74.0	-34.8	Peak	Vertical

Note 1: "\*" is not in restricted band, its limit is 20dBc of the fundamental emission level (89.2dBμV/m) or 15.209 which is higher.

Note 2: Measure Level (dBμV/m) = Reading Level (dBμV) + Factor (dB)

Factor (dB) = Cable Loss (dB) + Antenna Factor (dB/m) - Pre\_Amplifier Gain (dB)

Test Mode:	3DH5	Test Site:	AC1
Test Channel:	39	Test Engineer:	Roy Cheng
Remark:	1. Average measurement was not performed if peak level lower than average limit. 2. Other frequency was 20dB below limit line within 1-18GHz, there is not show in the report.		

Mark	Frequency (MHz)	Reading Level (dBμV)	Factor (dB)	Measure Level (dBμV/m)	Limit (dBμV/m)	Margin (dB)	Detector	Polarization
*	3511.0	37.4	-1.1	36.3	74.0	-37.7	Peak	Horizontal
*	4435.0	36.2	1.5	37.7	74.0	-36.3	Peak	Horizontal
	4681.0	36.6	2.3	38.9	74.0	-35.1	Peak	Horizontal
	5388.0	35.8	3.1	38.9	74.0	-35.1	Peak	Horizontal
*	3509.0	37.2	-1.1	36.1	74.0	-37.9	Peak	Vertical
*	4467.0	36.1	1.6	37.7	74.0	-36.3	Peak	Vertical
	4781.0	35.4	2.7	38.1	74.0	-35.9	Peak	Vertical
	5411.0	34.8	3.2	38.0	74.0	-36.0	Peak	Vertical

Note 1: "\*" is not in restricted band, its limit is 20dBc of the fundamental emission level (87.1dBμV/m) or 15.209 which is higher.

Note 2: Measure Level (dBμV/m) = Reading Level (dBμV) + Factor (dB)

Factor (dB) = Cable Loss (dB) + Antenna Factor (dB/m) - Pre\_Amplifier Gain (dB)

Test Mode:	3DH5	Test Site:	AC1
Test Channel:	78	Test Engineer:	Roy Cheng
Remark:	1. Average measurement was not performed if peak level lower than average limit. 2. Other frequency was 20dB below limit line within 1-18GHz, there is not show in the report.		

Mark	Frequency (MHz)	Reading Level (dBμV)	Factor (dB)	Measure Level (dBμV/m)	Limit (dBμV/m)	Margin (dB)	Detector	Polarization
*	3511.0	37.9	-1.1	36.9	74.0	-37.1	Peak	Horizontal
*	4455.0	36.2	1.5	37.7	74.0	-36.3	Peak	Horizontal
	5058.0	35.6	3.1	38.7	74.0	-35.3	Peak	Horizontal
	5399.0	35.2	3.1	38.3	74.0	-35.7	Peak	Horizontal
*	3555.0	38.2	-0.9	37.3	74.0	-36.7	Peak	Vertical
*	4428.0	35.7	1.5	37.2	74.0	-36.8	Peak	Vertical
	4691.0	35.9	2.3	38.2	74.0	-35.8	Peak	Vertical
	5402.0	36.1	3.1	39.2	74.0	-34.8	Peak	Vertical

Note 1: "\*" is not in restricted band, its limit is 20dBc of the fundamental emission level (85.5dBμV/m) or 15.209 which is higher.

Note 2: Measure Level (dBμV/m) = Reading Level (dBμV) + Factor (dB)

Factor (dB) = Cable Loss (dB) + Antenna Factor (dB/m) - Pre\_Amplifier Gain (dB)

**The worst case of Radiated Emission 9KHz ~ 1GHz and 18GHz ~ 25GHz:**

Site: AC 1	Time: 2015/09/30 - 16:13
Limit: FCC_Part15.209_RE(3m)	Engineer: Peak Wang
Probe: VULB9162_0.03-8GHz	Polarity: Horizontal
EUT: Audio Conference Phone	Power: AC 120V/60Hz
<b>Worse Case Mode:</b> Transmit at Channel 2402MHz by DH5	

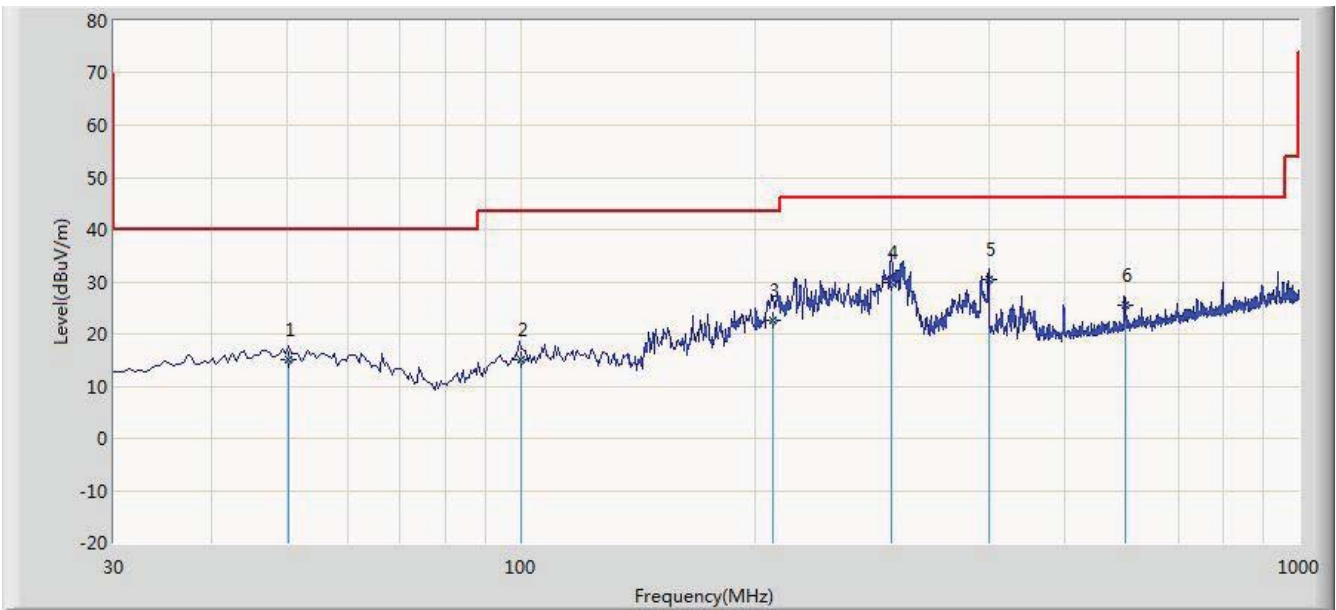

No	Flag	Mark	Frequency (MHz)	Measure Level (dBuV/m)	Reading Level (dBuV)	Over Limit (dB)	Limit (dBuV/m)	Factor (dB)	Type
1			50.410	15.040	0.140	-24.960	40.000	14.899	QP
2			99.940	15.021	2.080	-28.479	43.500	12.940	QP
3			210.510	22.568	10.170	-20.932	43.500	12.398	QP
4			299.204	29.964	15.470	-16.036	46.000	14.494	QP
5		*	400.040	30.494	13.840	-15.506	46.000	16.654	QP
6			597.551	25.645	5.710	-20.355	46.000	19.936	QP

Note: Measure Level (dB $\mu$ V/m) = Reading Level (dB $\mu$ V) + Factor (dB)

Factor (dB) = Cable Loss (dB) + Antenna Factor (dB/m)

Site: AC 1	Time: 2015/09/30 - 16:14
Limit: FCC_Part15.209_RE(3m)	Engineer: Peak Wang
Probe: VULB9162_0.03-8GHz	Polarity: Vertical
EUT: Audio Conference Phone	Power: AC 120V/60Hz
<b>Worse Case Mode: Transmit at Channel 2402MHz by DH5</b>	

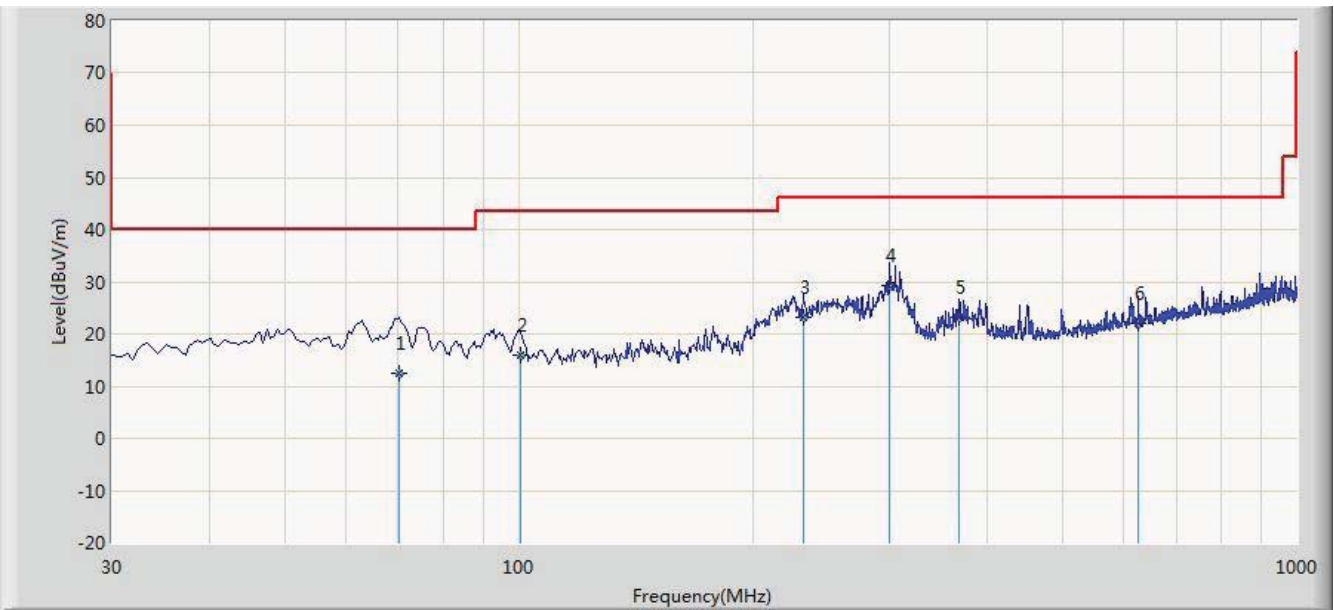

No	Flag	Mark	Frequency (MHz)	Measure Level (dBuV/m)	Reading Level (dBuV)	Over Limit (dB)	Limit (dBuV/m)	Factor (dB)	Type
1			70.304	12.599	1.800	-27.401	40.000	10.799	QP
2			100.410	15.841	2.840	-27.659	43.500	13.001	QP
3			232.304	23.183	10.080	-22.817	46.000	13.104	QP
4		*	300.040	29.232	14.720	-16.768	46.000	14.512	QP
5			368.600	23.131	7.070	-22.869	46.000	16.060	QP
6			626.070	22.113	1.840	-23.887	46.000	20.273	QP

Note: Measure Level (dBμV/m) = Reading Level (dBμV) + Factor (dB)

Factor (dB) = Cable Loss (dB) + Antenna Factor (dB/m)



Site: AC1	Time: 2015/09/25 - 15:34
Limit: FCC_Part15.209_RE(3m)	Engineer: Line Chen
Probe: FMZB1519_0.009-30MHz	Polarity: Face On
EUT: Audio Conference Phone	Power: AC 120V/60Hz
<b>Note: There is the ambient noise within frequency range 9kHz~30MHz.</b>	

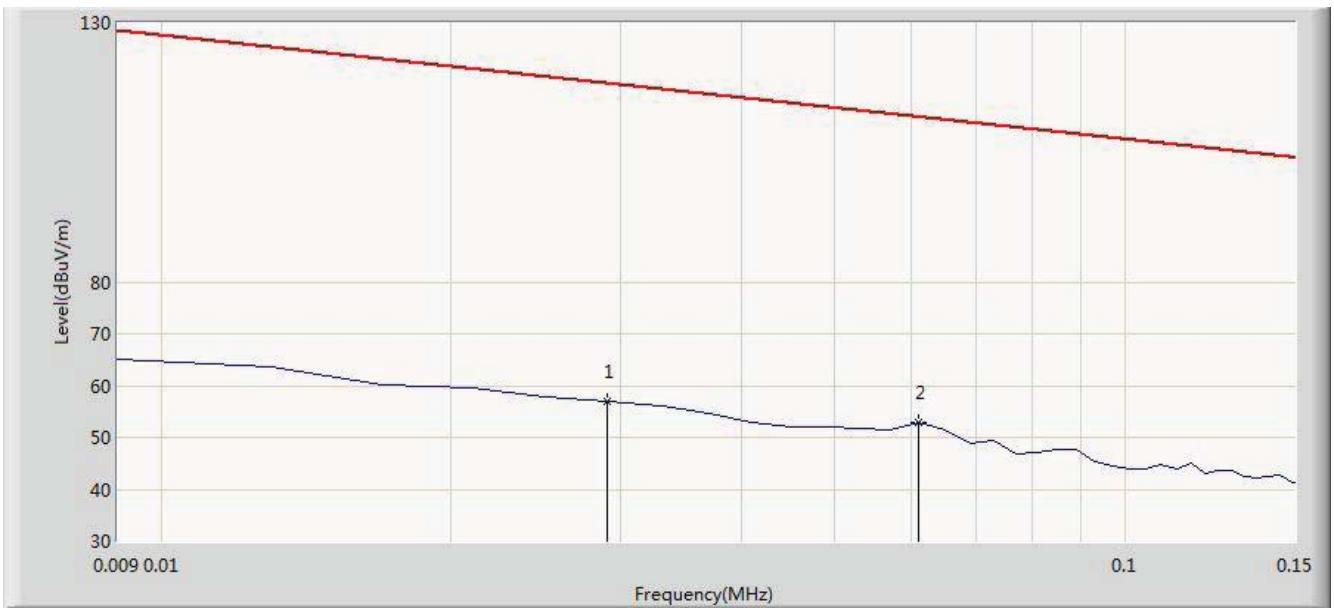

No	Flag	Mark	Frequency (MHz)	Measure Level (dBuV/m)	Reading Level (dBuV)	Over Limit (dB)	Limit (dBuV/m)	Factor (dB)	Type
1			0.029	56.893	35.844	-61.463	118.356	21.049	PK
2		*	0.061	52.853	32.542	-59.045	111.898	20.311	QP

Note: Measure Level (dB $\mu$ V/m) = Reading Level (dB $\mu$ V) + Factor (dB)

Factor (dB) = Cable Loss (dB) + Antenna Factor (dB/m)

Site: AC1	Time: 2015/09/25 - 15:45
Limit: FCC_Part15.209_RE(3m)	Engineer: Line Chen
Probe: FMZB1519_0.009-30MHz	Polarity: Face On
EUT: Audio Conference Phone	Power: AC 120V/60Hz
<b>Note: There is the ambient noise within frequency range 9kHz~30MHz.</b>	

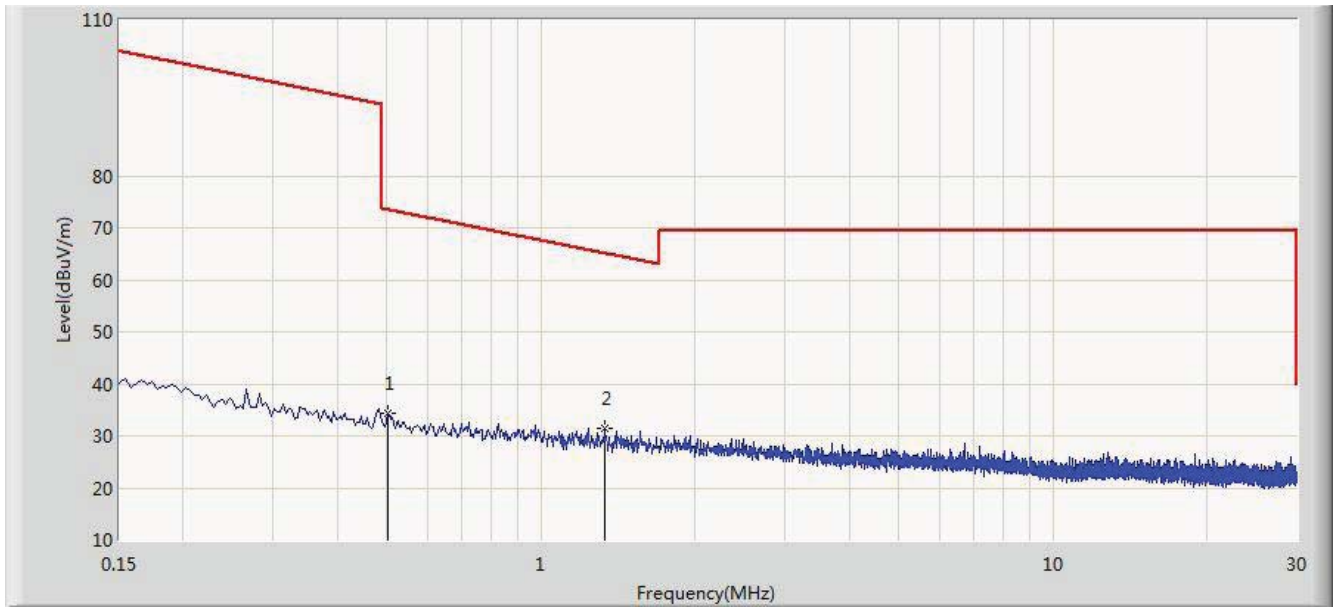

No	Flag	Mark	Frequency (MHz)	Measure Level (dBuV/m)	Reading Level (dBuV)	Over Limit (dB)	Limit (dBuV/m)	Factor (dB)	Type
1			0.502	34.370	13.947	-39.220	73.590	20.423	QP
2		*	1.334	31.595	11.104	-33.530	65.125	20.491	QP

Note: Measure Level (dB $\mu$ V/m) = Reading Level (dB $\mu$ V) + Factor (dB)

Factor (dB) = Cable Loss (dB) + Antenna Factor (dB/m)

Site: AC1	Time: 2015/09/25 - 16:12
Limit: FCC_Part15.209_RE(1m)	Engineer: Line Chen
Probe: BBHA9170_18-40GHz	Polarity: Horizontal
EUT: Audio Conference Phone	Power: AC 120V/60Hz
<b>Note: There is the ambient noise within frequency range 18GHz~25GHz.</b>	

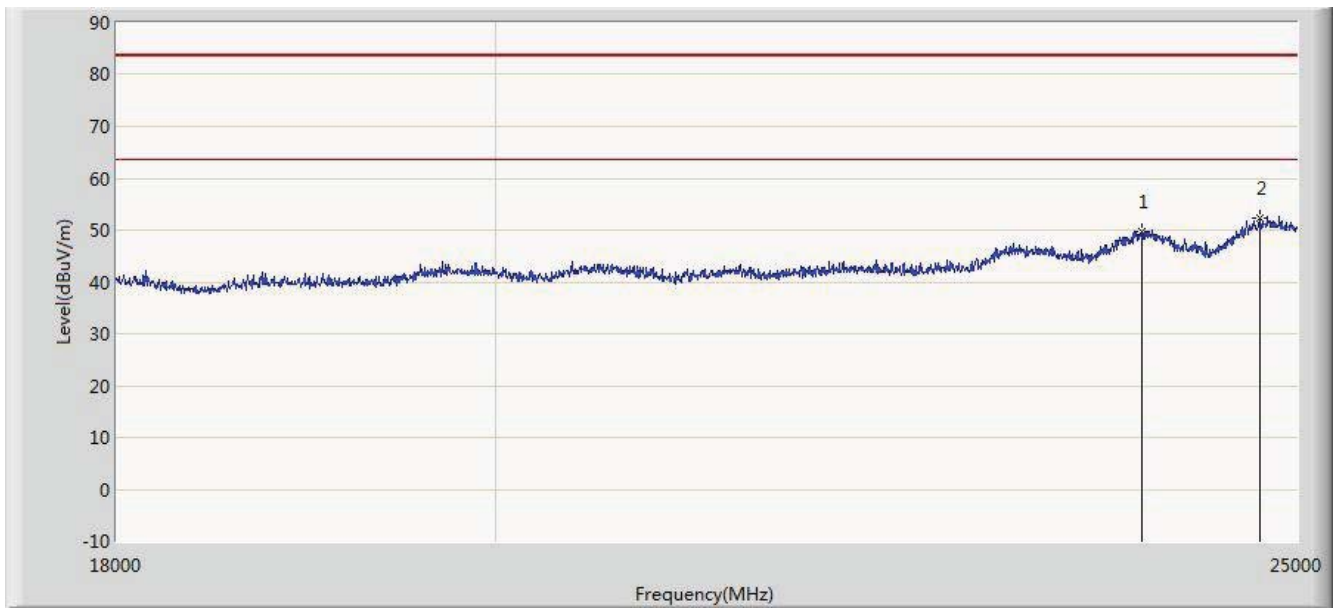

No	Flag	Mark	Frequency (MHz)	Measure Level (dBuV/m)	Reading Level (dBuV)	Over Limit (dB)	Limit (dBuV/m)	Factor (dB)	Type
1			23943.000	49.775	35.865	-33.725	83.500	13.910	PK
2		*	24741.000	52.373	37.679	-31.127	83.500	14.694	PK

Note: Measure Level (dBμV/m) = Reading Level (dBμV) + Factor (dB)

Factor (dB) = Cable Loss (dB) + Antenna Factor (dB/m) – Pre-Amplifier Gain (dB)

Limit@1m = 20\*Log(500uV/m) + 20\*Log(3m/1m) = 63.5dBμV/m (Average detector), and 83.5dBμV/m (Peak detector)

Site: AC1	Time: 2015/09/25 - 16:16
Limit: FCC_Part15.209_RE(1m)	Engineer: Line Chen
Probe: BBHA9170_18-40GHz	Polarity: Vertical
EUT: Audio Conference Phone	Power: AC 120V/60Hz
<b>Note: There is the ambient noise within frequency range 18GHz~25GHz.</b>	

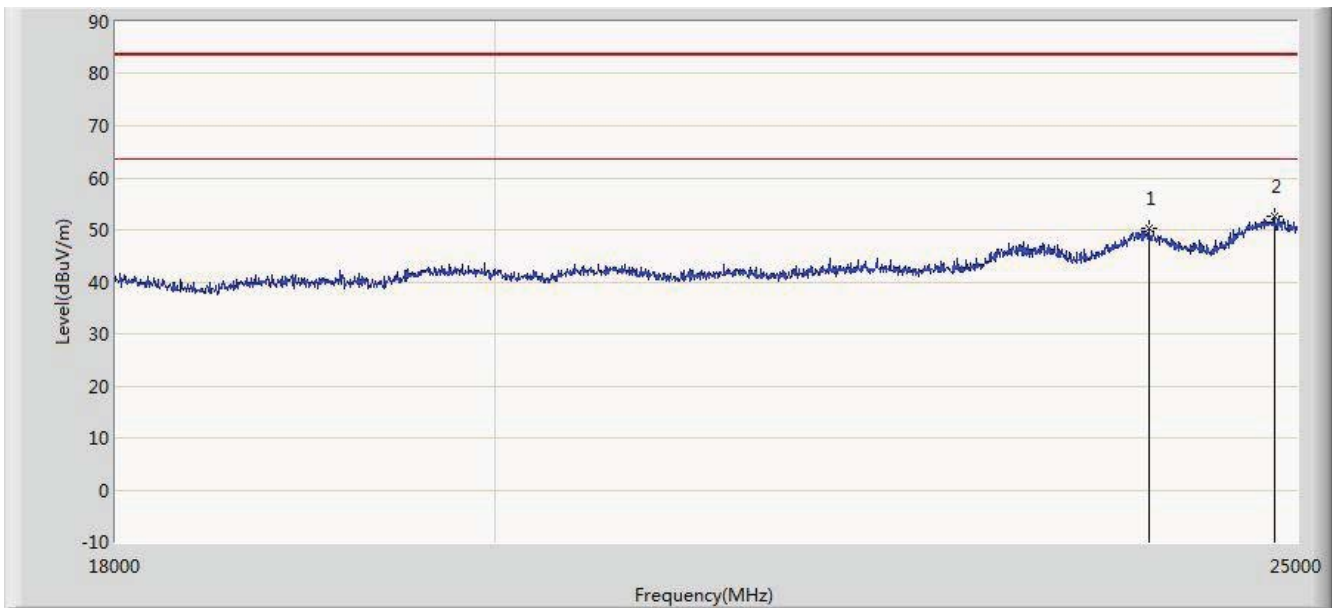

No	Flag	Mark	Frequency (MHz)	Measure Level (dBuV/m)	Reading Level (dBuV)	Over Limit (dB)	Limit (dBuV/m)	Factor (dB)	Type
1			23999.000	50.378	36.434	-33.122	83.500	13.944	PK
2		*	24846.000	52.500	37.732	-31.000	83.500	14.768	PK

Note: Measure Level (dB $\mu$ V/m) = Reading Level (dB $\mu$ V) + Factor (dB)

Factor (dB) = Cable Loss (dB) + Antenna Factor (dB/m) – Pre-Amplifier Gain (dB)

Limit@1m = 20\*Log(500uV/m) + 20\*Log(3m/1m) = 63.5dB $\mu$ V/m (Average detector), and 83.5dB $\mu$ V/m (Peak detector)

## 7.10. Radiated Restricted Band Edge Measurement

### 7.10.1. Test Result

Site: AC 1	Time: 2015/09/19 - 14:07
Limit: FCC_Part15.209_RE(3m)	Engineer: Milo Li
Probe: BBHA9120D_1-18GHz	Polarity: Horizontal
EUT: Audio Conference Phone	Power: AC 120V/60Hz
Test Mode: Transmit at channel 2402MHz by DH5	

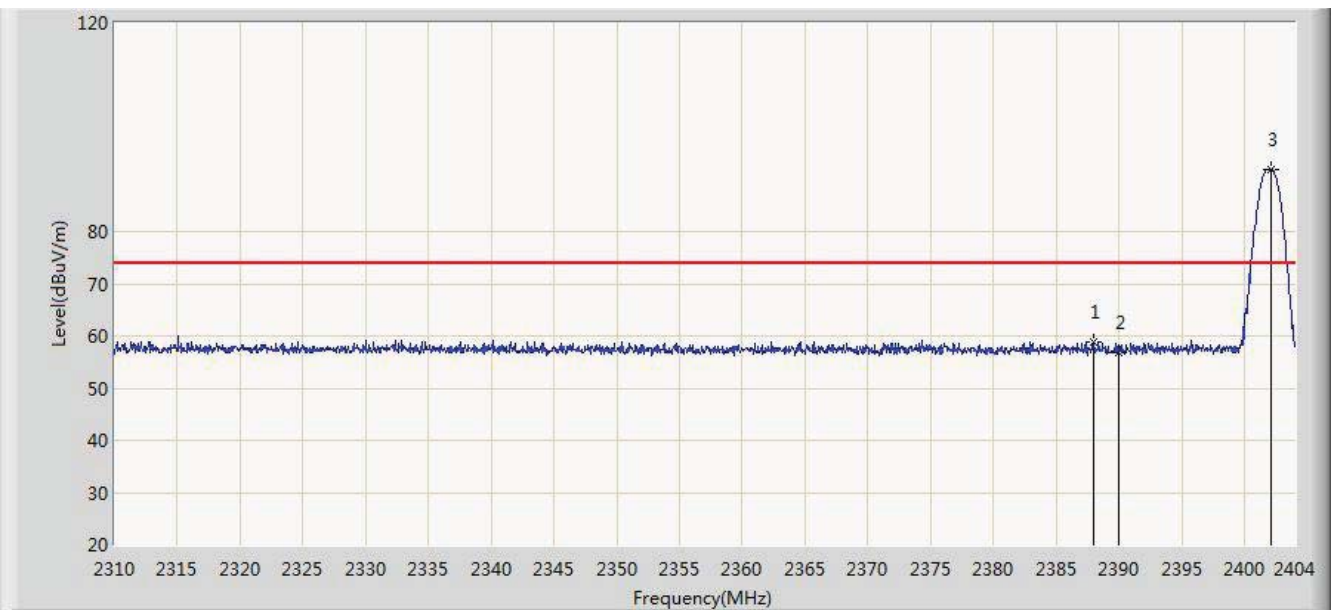

No	Flag	Mark	Frequency (MHz)	Measure Level (dBuV/m)	Reading Level (dBuV)	Over Limit (dB)	Limit (dBuV/m)	Factor (dB)	Type
1			2388.020	58.723	27.517	-15.277	74.000	31.206	PK
2			2390.000	56.796	25.593	-17.204	74.000	31.203	PK
3		*	2402.073	91.821	60.637	N/A	N/A	31.184	PK

Note: Measure Level (dB $\mu$ V/m) = Reading Level (dB $\mu$ V) + Factor (dB)

Factor (dB) = Cable Loss (dB) + Antenna Factor (dB/m)

Site: AC 1	Time: 2015/09/19 - 14:11
Limit: FCC_Part15.209_RE(3m)	Engineer: Milo Li
Probe: BBHA9120D_1-18GHz	Polarity: Horizontal
EUT: Audio Conference Phone	Power: AC 120V/60Hz
Test Mode: Transmit at channel 2402MHz by DH5	

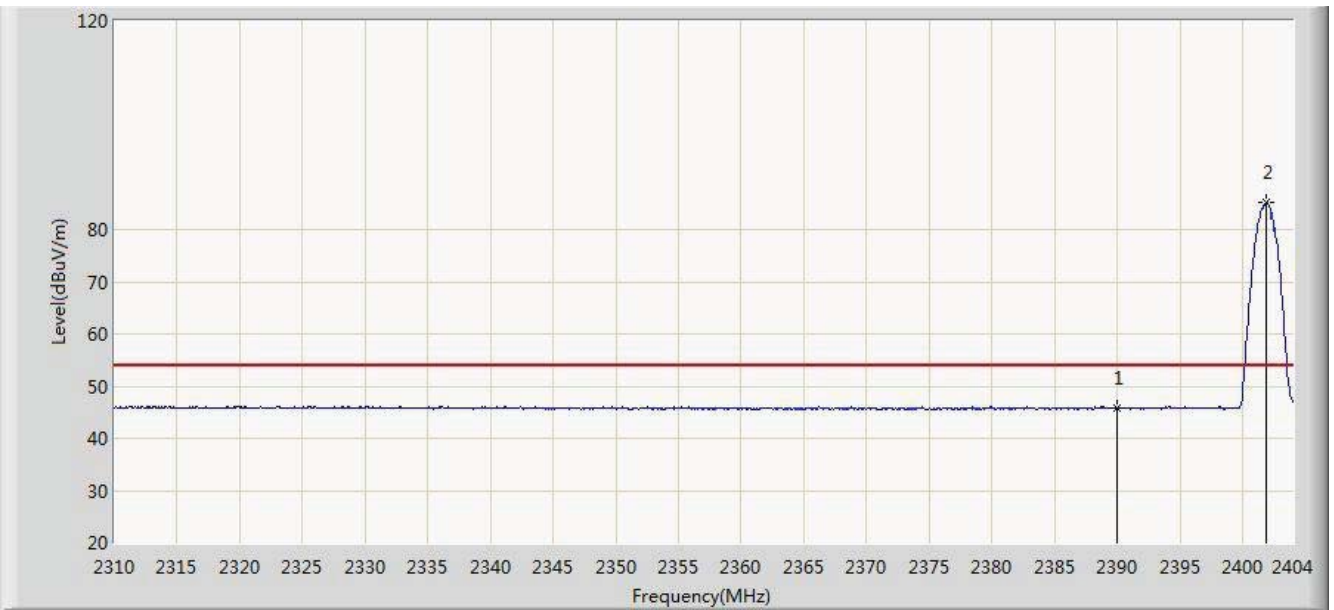

No	Flag	Mark	Frequency (MHz)	Measure Level (dBuV/m)	Reading Level (dBuV)	Over Limit (dB)	Limit (dBuV/m)	Factor (dB)	Type
1			2390.000	45.781	14.578	-8.219	54.000	31.203	AV
2		*	2401.838	85.151	53.967	N/A	N/A	31.184	AV

Note: Measure Level (dB $\mu$ V/m) = Reading Level (dB $\mu$ V) + Factor (dB)

Factor (dB) = Cable Loss (dB) + Antenna Factor (dB/m)

Remark: Only worse case is reported

Site: AC 1	Time: 2015/09/19 - 14:30
Limit: FCC_Part15.209_RE(3m)	Engineer: Milo Li
Probe: BBHA9120D_1-18GHz	Polarity: Vertical
EUT: Audio Conference Phone	Power: AC 120V/60Hz
Test Mode: Transmit at channel 2402MHz by DH5	

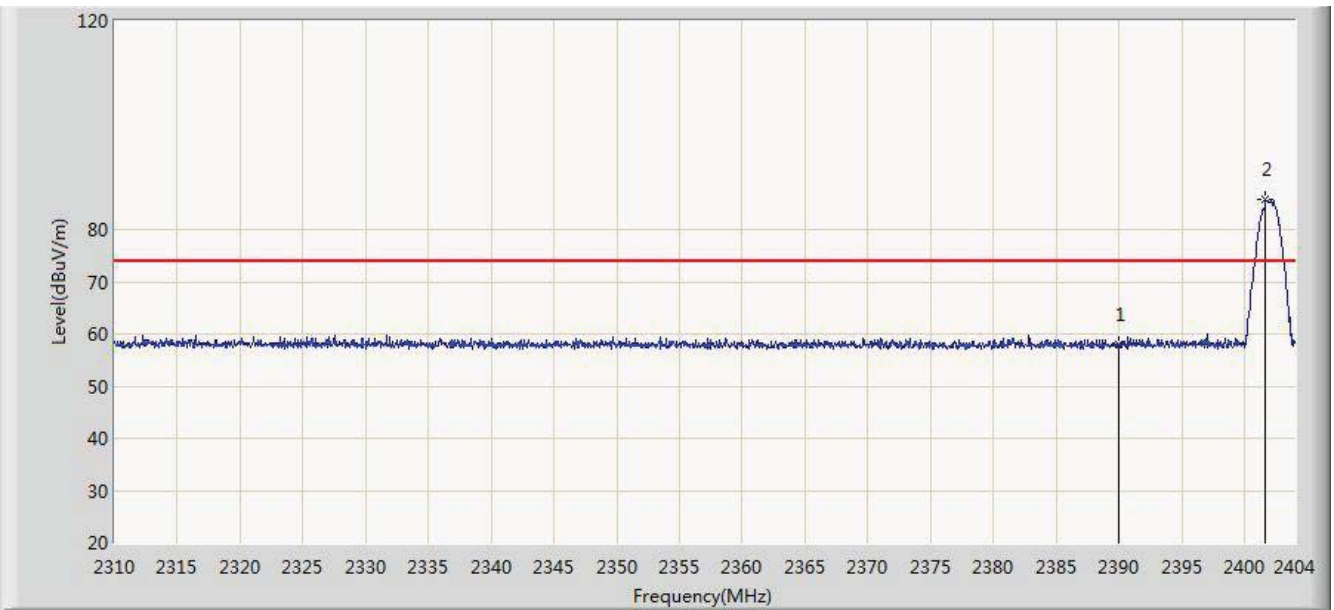

No	Flag	Mark	Frequency (MHz)	Measure Level (dBuV/m)	Reading Level (dBuV)	Over Limit (dB)	Limit (dBuV/m)	Factor (dB)	Type
1			2390.000	57.846	26.643	-16.154	74.000	31.203	PK
2		*	2401.650	85.708	54.523	N/A	N/A	31.184	PK

Note: Measure Level (dB $\mu$ V/m) = Reading Level (dB $\mu$ V) + Factor (dB)

Factor (dB) = Cable Loss (dB) + Antenna Factor (dB/m)

Site: AC 1	Time: 2015/09/19 - 14:31
Limit: FCC_Part15.209_RE(3m)	Engineer: Milo Li
Probe: BBHA9120D_1-18GHz	Polarity: Vertical
EUT: Audio Conference Phone	Power: AC 120V/60Hz
Test Mode: Transmit at channel 2402MHz by DH5	

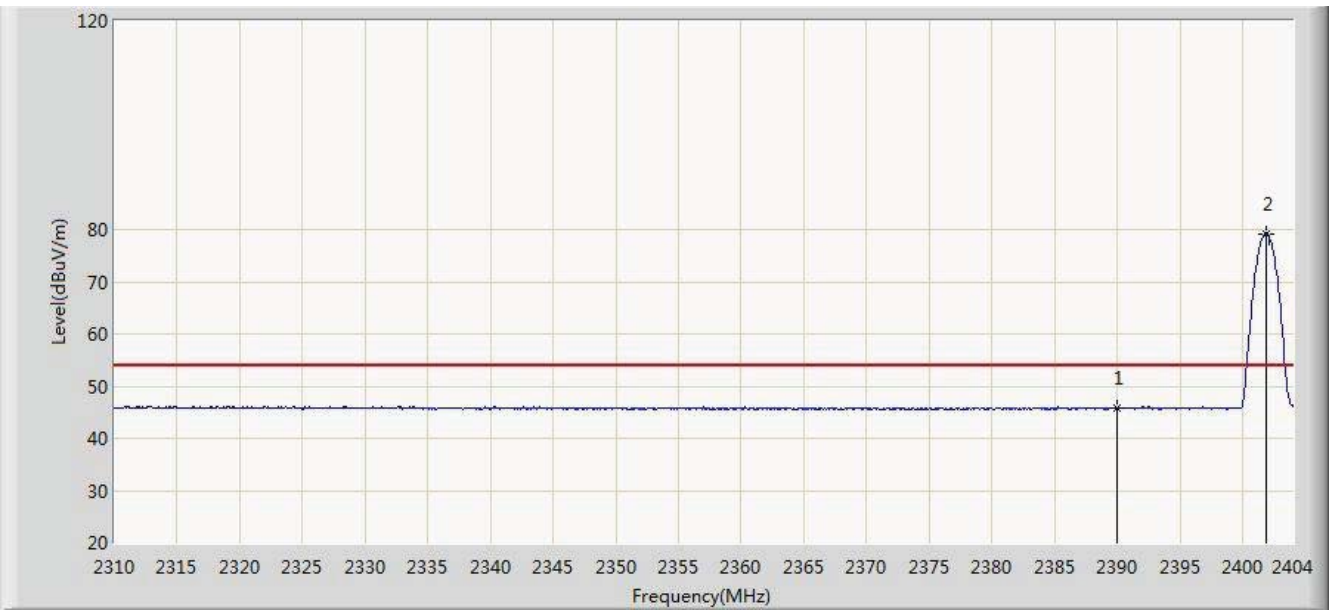

No	Flag	Mark	Frequency (MHz)	Measure Level (dBuV/m)	Reading Level (dBuV)	Over Limit (dB)	Limit (dBuV/m)	Factor (dB)	Type
1			2390.000	45.780	14.577	-8.220	54.000	31.203	AV
2		*	2401.885	79.240	48.056	N/A	N/A	31.184	AV

Note: Measure Level (dB $\mu$ V/m) = Reading Level (dB $\mu$ V) + Factor (dB)

Factor (dB) = Cable Loss (dB) + Antenna Factor (dB/m)



Site: AC 1	Time: 2015/09/19 - 14:33
Limit: FCC_Part15.209_RE(3m)	Engineer: Milo Li
Probe: BBHA9120D_1-18GHz	Polarity: Horizontal
EUT: Audio Conference Phone	Power: AC 120V/60Hz
Test Mode: Transmit at channel 2480MHz by DH5	

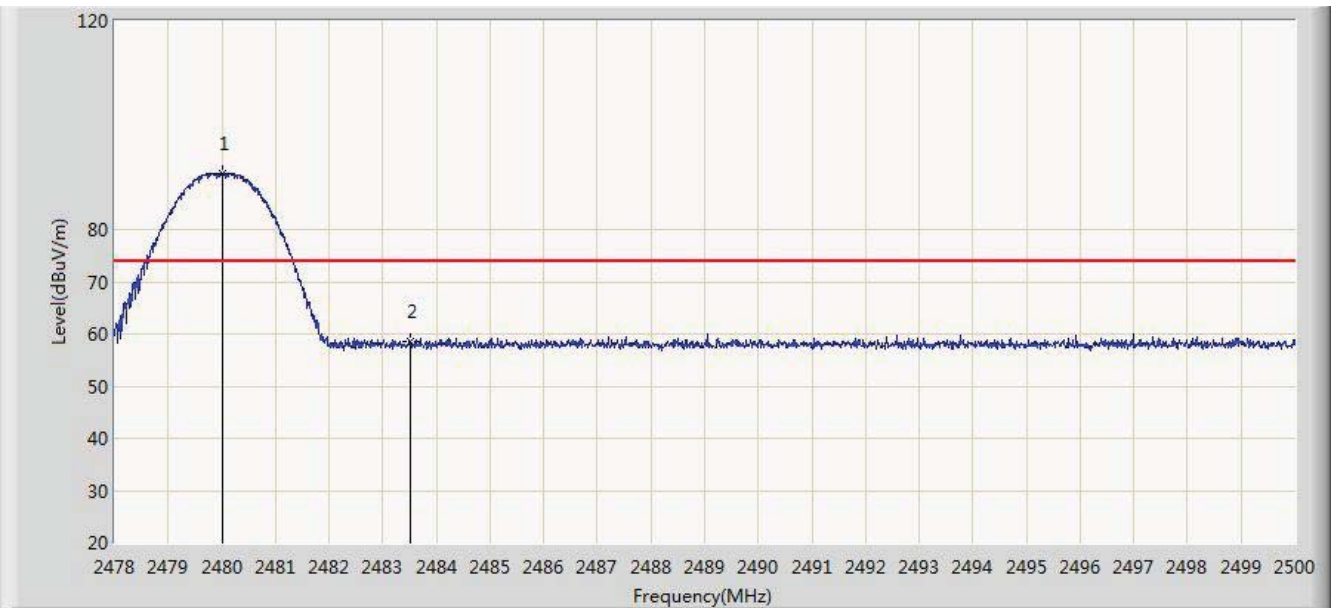

No	Flag	Mark	Frequency (MHz)	Measure Level (dBuV/m)	Reading Level (dBuV)	Over Limit (dB)	Limit (dBuV/m)	Factor (dB)	Type
1		*	2480.002	90.656	59.472	N/A	N/A	31.184	PK
2			2483.500	58.492	27.299	-15.508	74.000	31.194	PK

Note: Measure Level (dB $\mu$ V/m) = Reading Level (dB $\mu$ V) + Factor (dB)

Factor (dB) = Cable Loss (dB) + Antenna Factor (dB/m)

Site: AC 1	Time: 2015/09/19 - 14:35
Limit: FCC_Part15.209_RE(3m)	Engineer: Milo Li
Probe: BBHA9120D_1-18GHz	Polarity: Horizontal
EUT: Audio Conference Phone	Power: AC 120V/60Hz
Test Mode: Transmit at channel 2480MHz by DH5	

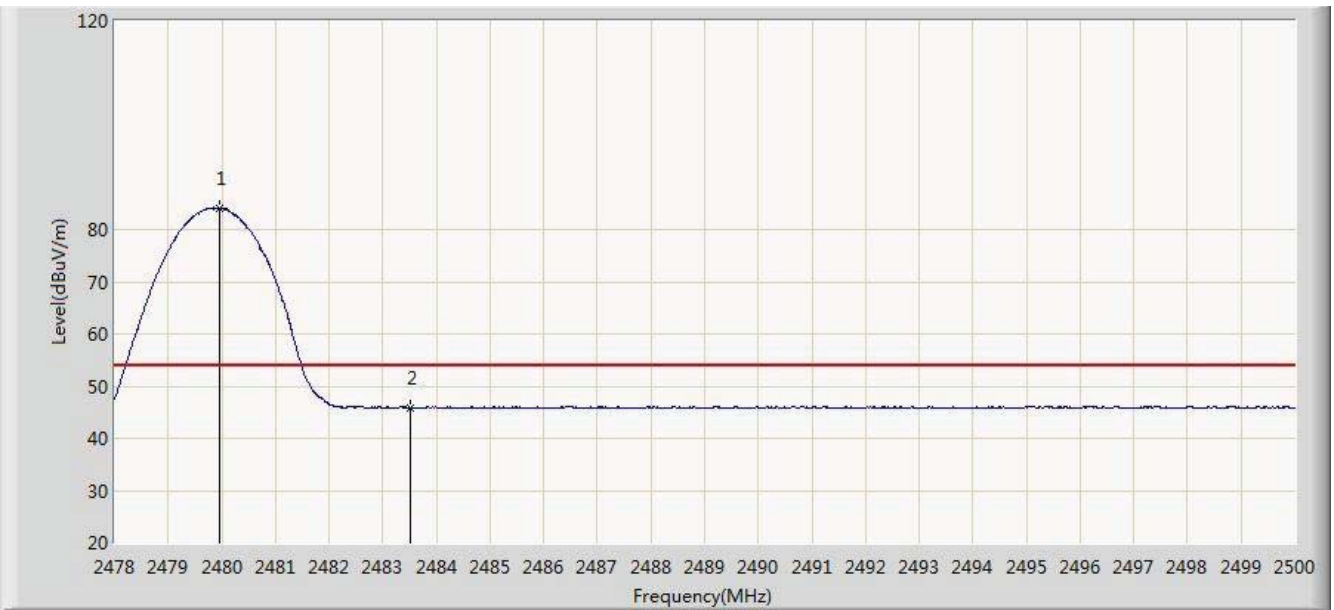

No	Flag	Mark	Frequency (MHz)	Measure Level (dBuV/m)	Reading Level (dBuV)	Over Limit (dB)	Limit (dBuV/m)	Factor (dB)	Type
1		*	2479.969	84.142	52.958	N/A	N/A	31.184	AV
2			2483.500	45.819	14.626	-8.181	54.000	31.194	AV

Note: Measure Level (dB $\mu$ V/m) = Reading Level (dB $\mu$ V) + Factor (dB)

Factor (dB) = Cable Loss (dB) + Antenna Factor (dB/m)

Site: AC 1	Time: 2015/09/19 - 14:36
Limit: FCC_Part15.209_RE(3m)	Engineer: Milo Li
Probe: BBHA9120D_1-18GHz	Polarity: Vertical
EUT: Audio Conference Phone	Power: AC 120V/60Hz
Test Mode: Transmit at channel 2480MHz by DH5	

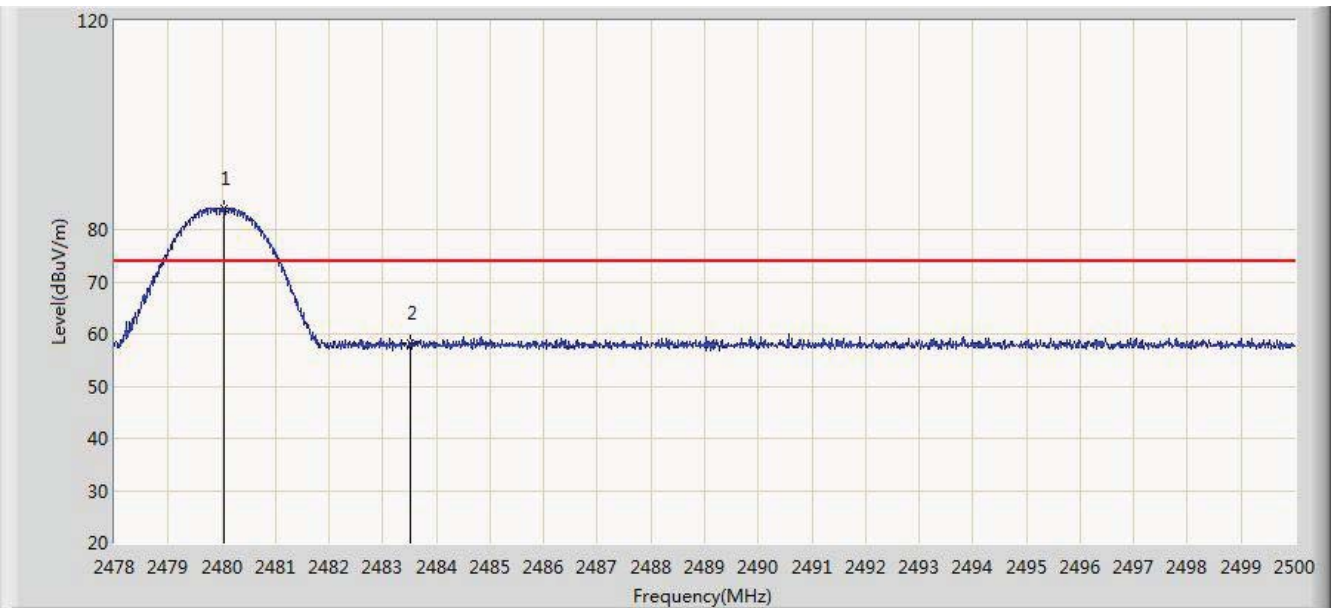

No	Flag	Mark	Frequency (MHz)	Measure Level (dBuV/m)	Reading Level (dBuV)	Over Limit (dB)	Limit (dBuV/m)	Factor (dB)	Type
1		*	2480.046	83.985	52.801	N/A	N/A	31.184	PK
2			2483.500	58.320	27.127	-15.680	74.000	31.194	PK

Note: Measure Level (dB $\mu$ V/m) = Reading Level (dB $\mu$ V) + Factor (dB)

Factor (dB) = Cable Loss (dB) + Antenna Factor (dB/m)

Site: AC 1	Time: 2015/09/19 - 14:37
Limit: FCC_Part15.209_RE(3m)	Engineer: Milo Li
Probe: BBHA9120D_1-18GHz	Polarity: Vertical
EUT: Audio Conference Phone	Power: AC 120V/60Hz
Test Mode: Transmit at channel 2480MHz by DH5	



No	Flag	Mark	Frequency (MHz)	Measure Level (dBuV/m)	Reading Level (dBuV)	Over Limit (dB)	Limit (dBuV/m)	Factor (dB)	Type
1		*	2479.936	77.406	46.222	N/A	N/A	31.184	AV
2			2483.500	45.909	14.716	-8.091	54.000	31.194	AV

Note: Measure Level (dB $\mu$ V/m) = Reading Level (dB $\mu$ V) + Factor (dB)

Factor (dB) = Cable Loss (dB) + Antenna Factor (dB/m)

Site: AC 1	Time: 2015/09/19 - 14:40
Limit: FCC_Part15.209_RE(3m)	Engineer: Milo Li
Probe: BBHA9120D_1-18GHz	Polarity: Horizontal
EUT: Audio Conference Phone	Power: AC 120V/60Hz
Test Mode: Transmit at channel 2402MHz by 2DH5	

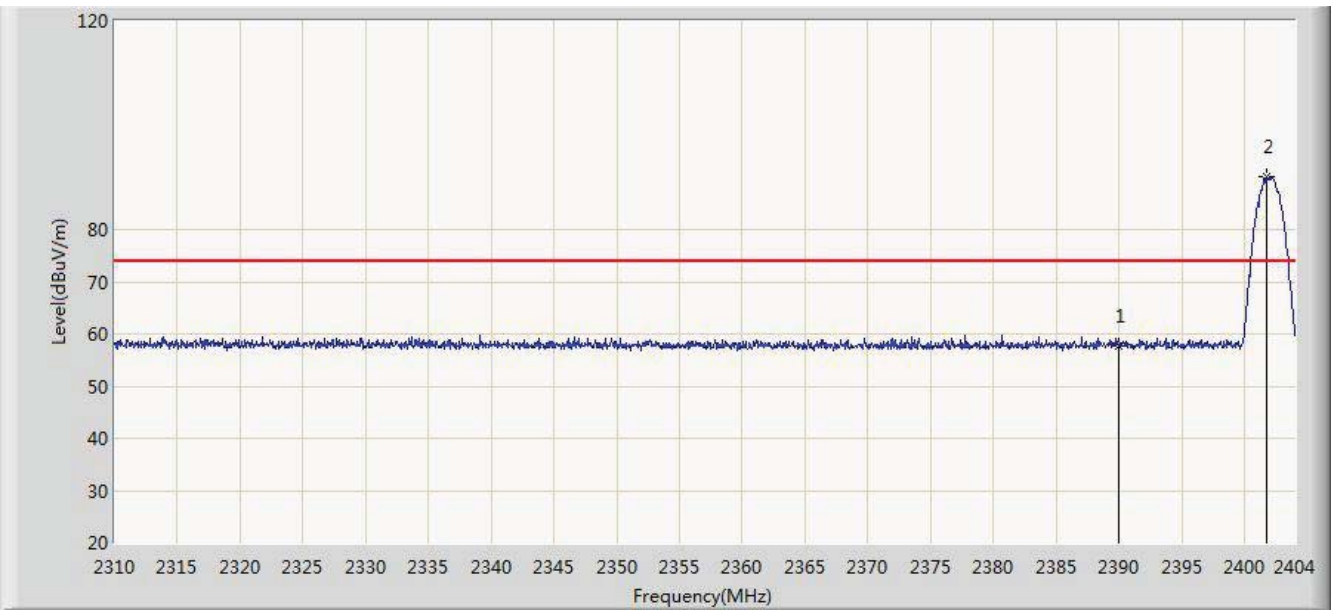

No	Flag	Mark	Frequency (MHz)	Measure Level (dBuV/m)	Reading Level (dBuV)	Over Limit (dB)	Limit (dBuV/m)	Factor (dB)	Type
1			2390.000	57.643	26.440	-16.357	74.000	31.203	PK
2		*	2401.791	90.136	58.952	N/A	N/A	31.184	PK

Note: Measure Level (dB $\mu$ V/m) = Reading Level (dB $\mu$ V) + Factor (dB)

Factor (dB) = Cable Loss (dB) + Antenna Factor (dB/m)

Site: AC 1	Time: 2015/09/19 - 14:42
Limit: FCC_Part15.209_RE(3m)	Engineer: Milo Li
Probe: BBHA9120D_1-18GHz	Polarity: Horizontal
EUT: Audio Conference Phone	Power: AC 120V/60Hz
Test Mode: Transmit at channel 2402MHz by 2DH5	

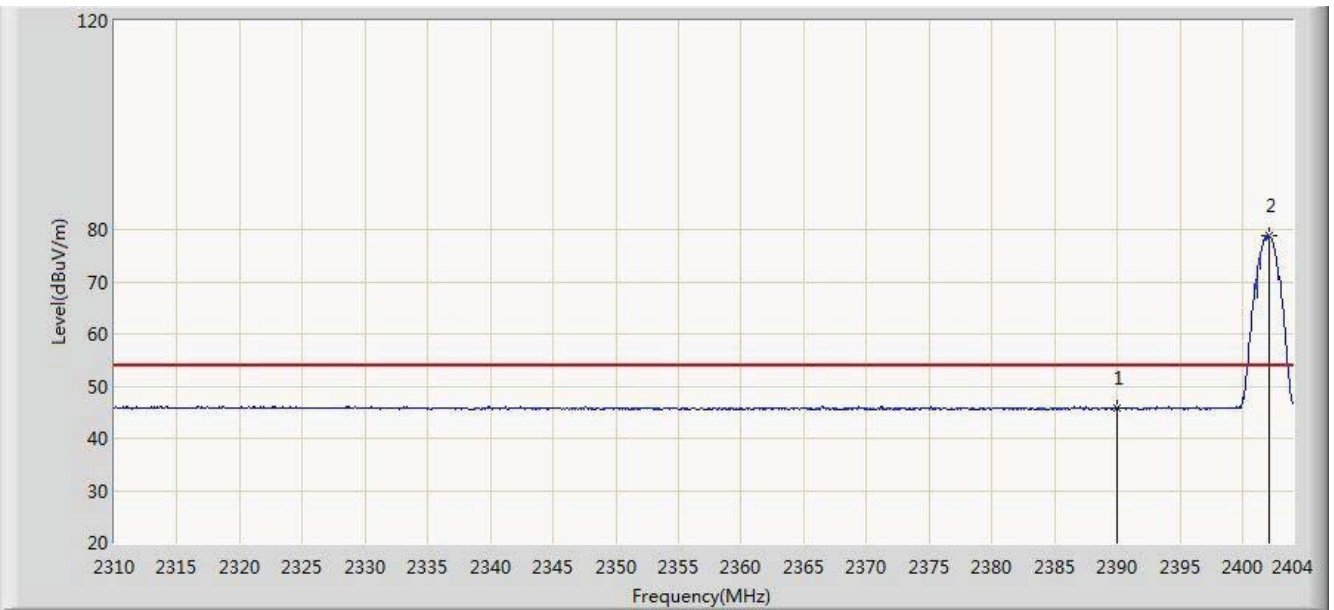

aa	Flag	Mark	Frequency (MHz)	Measure Level (dBuV/m)	Reading Level (dBuV)	Over Limit (dB)	Limit (dBuV/m)	Factor (dB)	Type
1			2390.000	45.687	14.484	-8.313	54.000	31.203	AV
2		*	2402.120	78.752	47.568	N/A	N/A	31.184	AV

Note: Measure Level (dB $\mu$ V/m) = Reading Level (dB $\mu$ V) + Factor (dB)

Factor (dB) = Cable Loss (dB) + Antenna Factor (dB/m)

Site: AC 1	Time: 2015/09/19 - 14:42
Limit: FCC_Part15.209_RE(3m)	Engineer: Milo Li
Probe: BBHA9120D_1-18GHz	Polarity: Vertical
EUT: Audio Conference Phone	Power: AC 120V/60Hz
Test Mode: Transmit at channel 2402MHz by 2DH5	

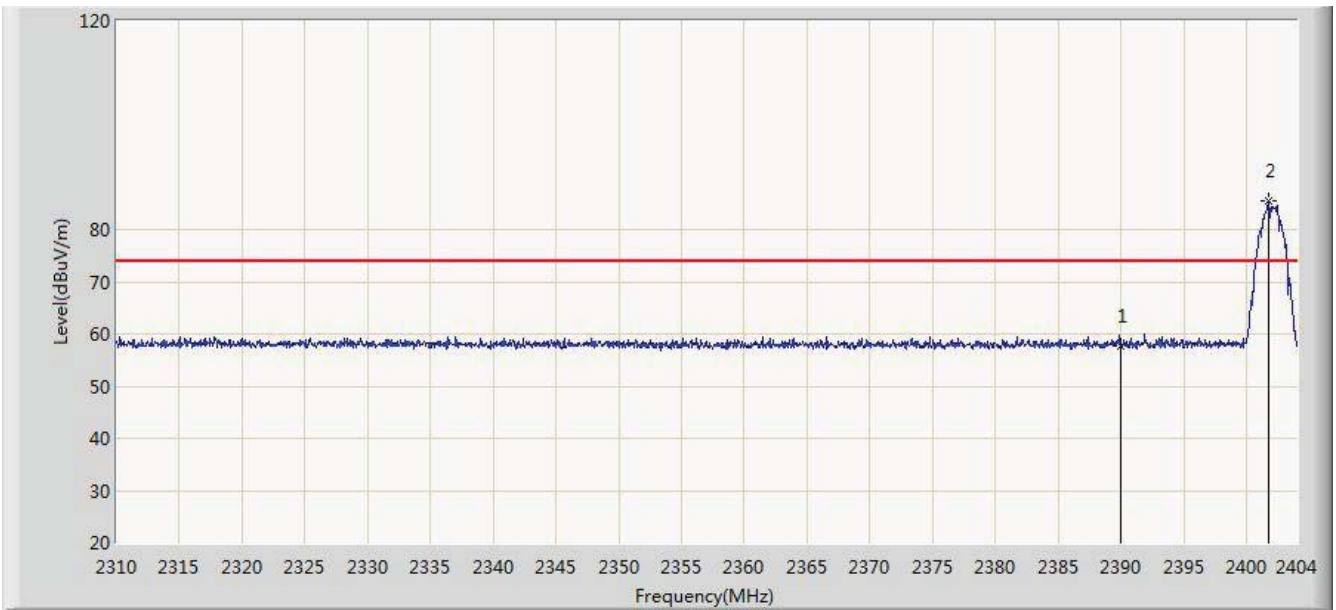

No	Flag	Mark	Frequency (MHz)	Measure Level (dBuV/m)	Reading Level (dBuV)	Over Limit (dB)	Limit (dBuV/m)	Factor (dB)	Type
1			2390.000	57.759	26.556	-16.241	74.000	31.203	PK
2		*	2401.744	85.598	54.414	N/A	N/A	31.184	PK

Note: Measure Level (dB $\mu$ V/m) = Reading Level (dB $\mu$ V) + Factor (dB)

Factor (dB) = Cable Loss (dB) + Antenna Factor (dB/m)

Site: AC 1	Time: 2015/09/19 - 14:44
Limit: FCC_Part15.209_RE(3m)	Engineer: Milo Li
Probe: BBHA9120D_1-18GHz	Polarity: Vertical
EUT: Audio Conference Phone	Power: AC 120V/60Hz
Test Mode: Transmit at channel 2402MHz by 2DH5	

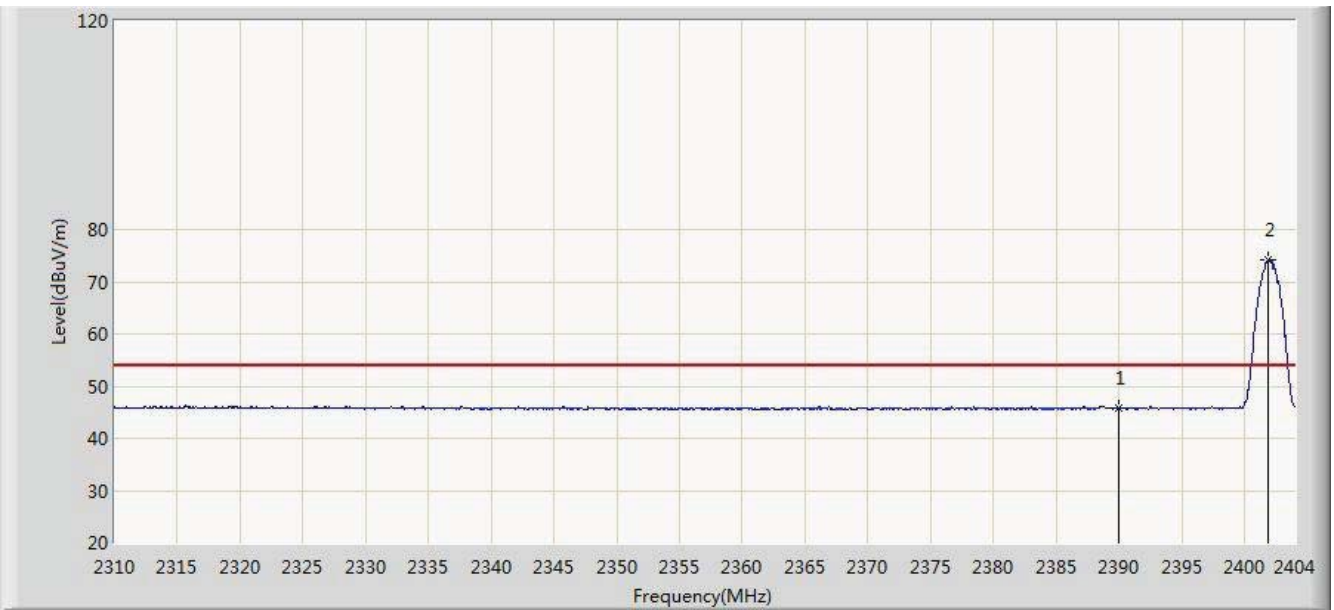

No	Flag	Mark	Frequency (MHz)	Measure Level (dBuV/m)	Reading Level (dBuV)	Over Limit (dB)	Limit (dBuV/m)	Factor (dB)	Type
1			2390.000	45.881	14.678	-8.119	54.000	31.203	AV
2		*	2401.932	74.243	43.059	N/A	N/A	31.184	AV

Note: Measure Level (dB $\mu$ V/m) = Reading Level (dB $\mu$ V) + Factor (dB)

Factor (dB) = Cable Loss (dB) + Antenna Factor (dB/m)



Site: AC 1	Time: 2015/09/19 - 14:46
Limit: FCC_Part15.209_RE(3m)	Engineer: Milo Li
Probe: BBHA9120D_1-18GHz	Polarity: Horizontal
EUT: Audio Conference Phone	Power: AC 120V/60Hz
Test Mode: Transmit at channel 2480MHz by 2DH5	

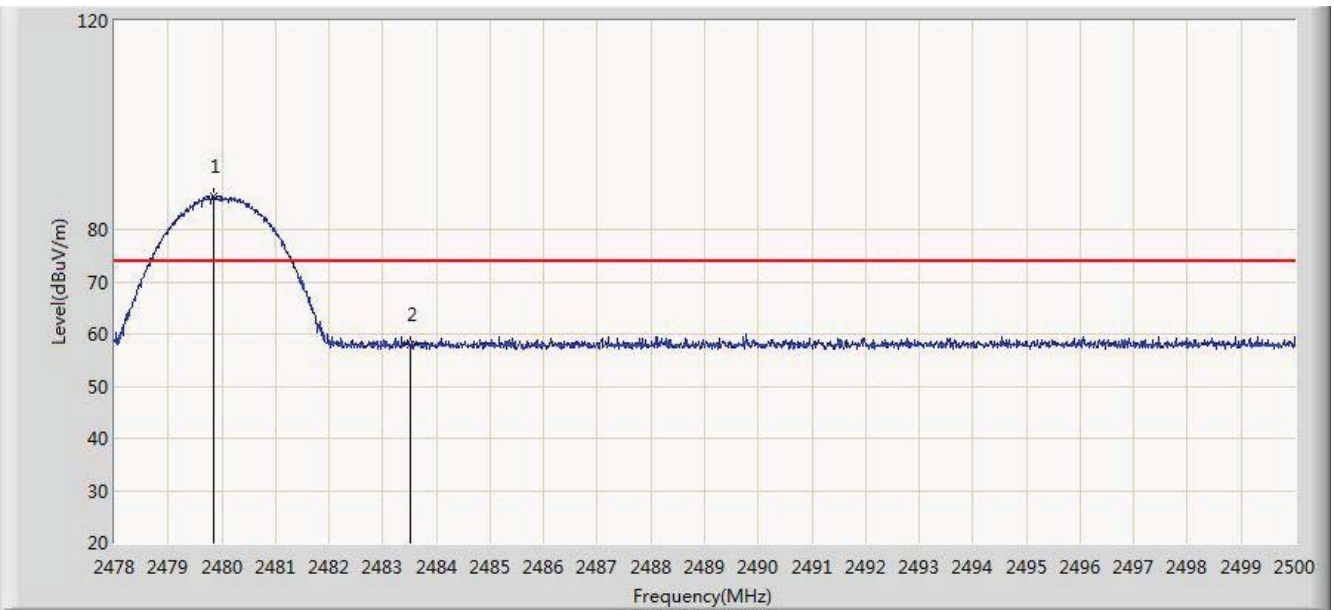

No	Flag	Mark	Frequency (MHz)	Measure Level (dBuV/m)	Reading Level (dBuV)	Over Limit (dB)	Limit (dBuV/m)	Factor (dB)	Type
1		*	2479.848	86.347	55.163	N/A	N/A	31.184	PK
2			2483.500	57.960	26.767	-16.040	74.000	31.194	PK

Note: Measure Level (dB $\mu$ V/m) = Reading Level (dB $\mu$ V) + Factor (dB)

Factor (dB) = Cable Loss (dB) + Antenna Factor (dB/m)

Site: AC 1	Time: 2015/09/19 - 14:47
Limit: FCC_Part15.209_RE(3m)	Engineer: Milo Li
Probe: BBHA9120D_1-18GHz	Polarity: Horizontal
EUT: Audio Conference Phone	Power: AC 120V/60Hz
Test Mode: Transmit at channel 2480MHz by 2DH5	

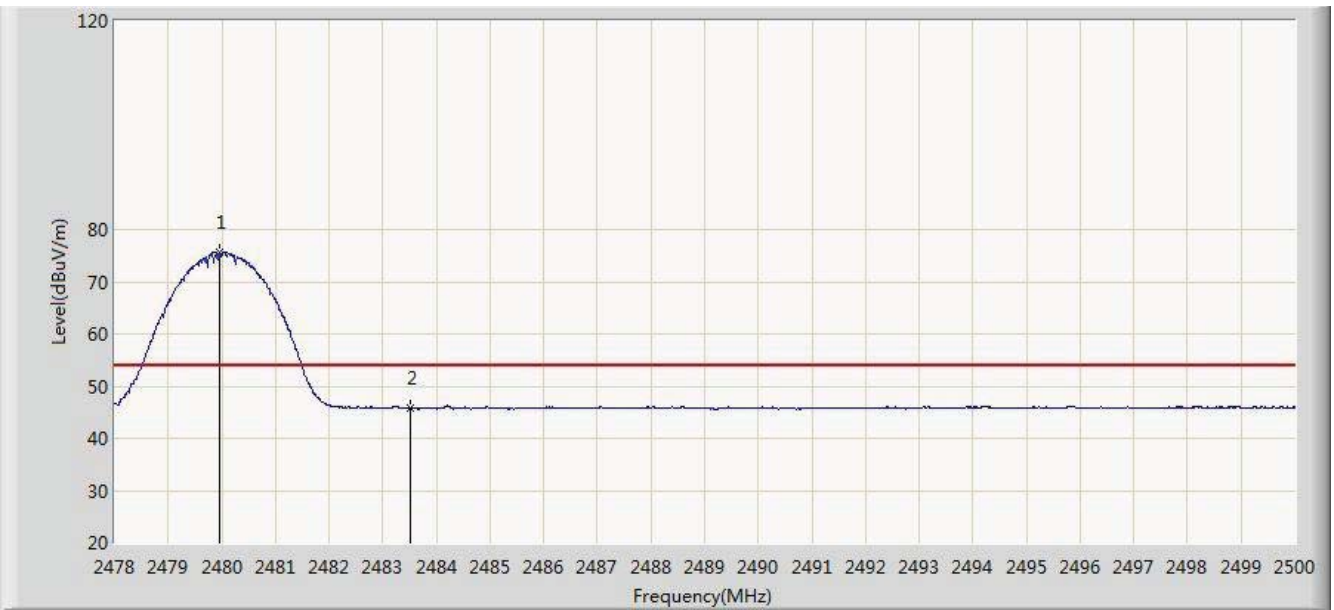

No	Flag	Mark	Frequency (MHz)	Measure Level (dBuV/m)	Reading Level (dBuV)	Over Limit (dB)	Limit (dBuV/m)	Factor (dB)	Type
1		*	2479.958	75.587	44.403	N/A	N/A	31.184	AV
2			2483.500	45.693	14.500	-8.307	54.000	31.194	AV

Note: Measure Level (dB $\mu$ V/m) = Reading Level (dB $\mu$ V) + Factor (dB)

Factor (dB) = Cable Loss (dB) + Antenna Factor (dB/m)

Site: AC 1	Time: 2015/09/19 - 14:48
Limit: FCC_Part15.209_RE(3m)	Engineer: Milo Li
Probe: BBHA9120D_1-18GHz	Polarity: Vertical
EUT: Audio Conference Phone	Power: AC 120V/60Hz
Test Mode: Transmit at channel 2480MHz by 2DH5	

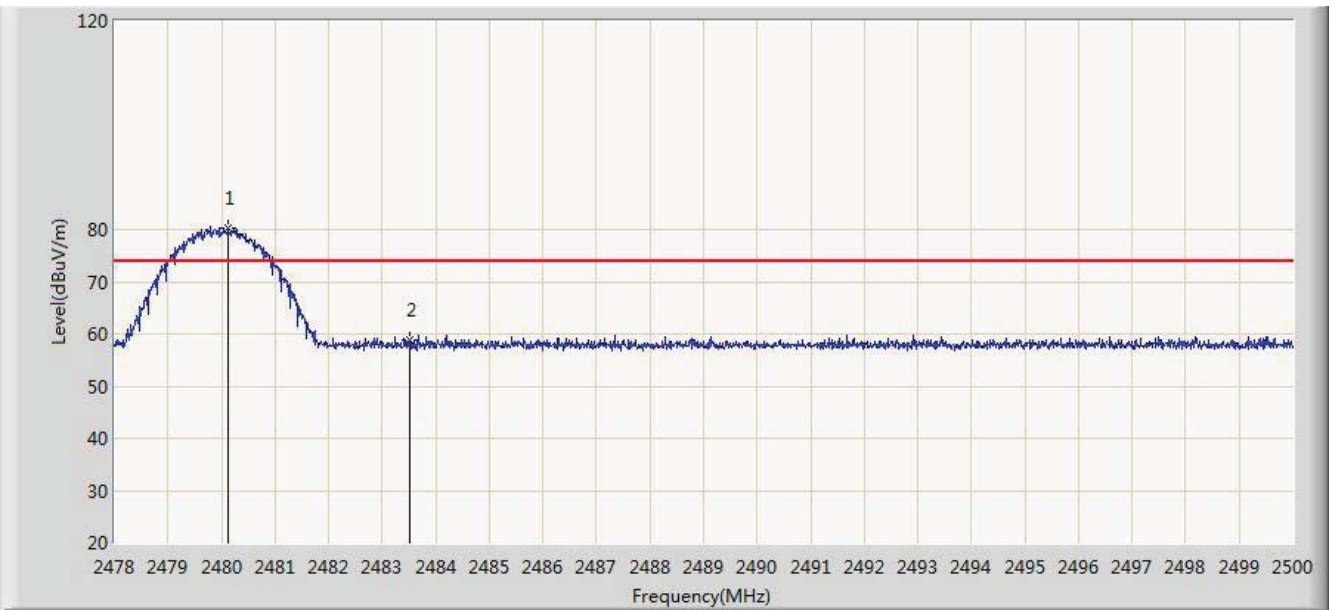

No	Flag	Mark	Frequency (MHz)	Measure Level (dBuV/m)	Reading Level (dBuV)	Over Limit (dB)	Limit (dBuV/m)	Factor (dB)	Type
1		*	2480.123	80.182	48.998	N/A	N/A	31.185	PK
2			2483.500	58.982	27.789	-15.018	74.000	31.194	PK

Note: Measure Level (dB $\mu$ V/m) = Reading Level (dB $\mu$ V) + Factor (dB)

Factor (dB) = Cable Loss (dB) + Antenna Factor (dB/m)

Site: AC 1	Time: 2015/09/19 - 14:49
Limit: FCC_Part15.209_RE(3m)	Engineer: Milo Li
Probe: BBHA9120D_1-18GHz	Polarity: Vertical
EUT: Audio Conference Phone	Power: AC 120V/60Hz
Test Mode: Transmit at channel 2480MHz by 2DH5	

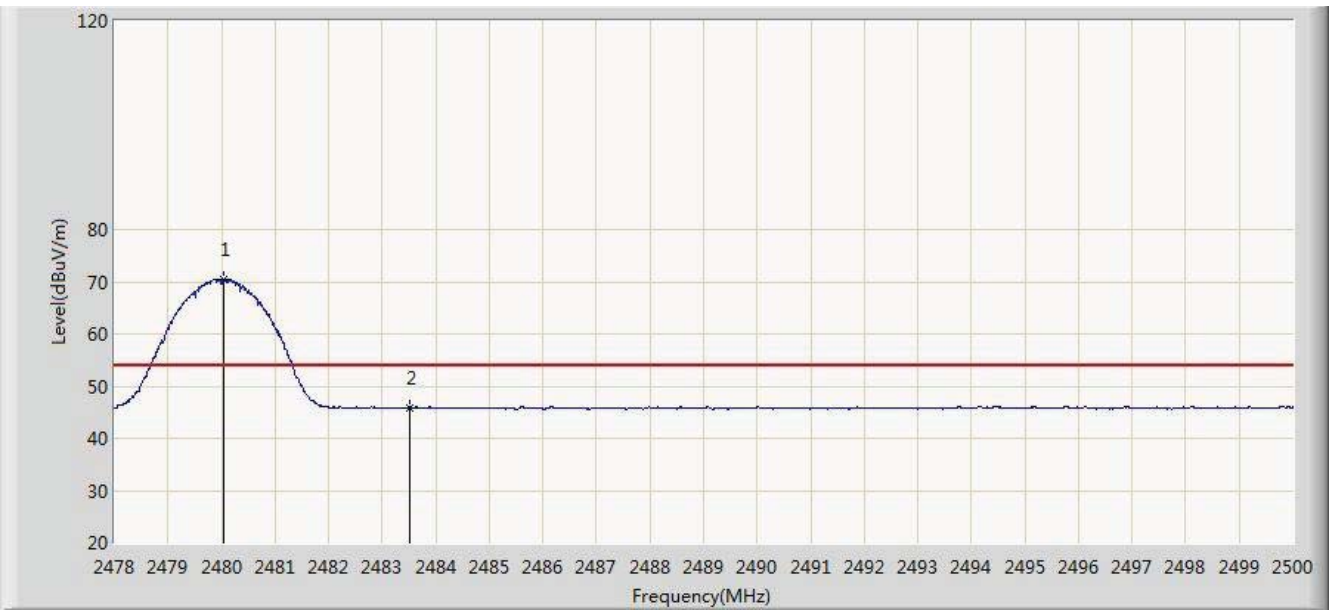

No	Flag	Mark	Frequency (MHz)	Measure Level (dBuV/m)	Reading Level (dBuV)	Over Limit (dB)	Limit (dBuV/m)	Factor (dB)	Type
1		*	2480.035	70.510	39.326	N/A	N/A	31.184	AV
2			2483.500	45.825	14.632	-8.175	54.000	31.194	AV

Note: Measure Level (dB $\mu$ V/m) = Reading Level (dB $\mu$ V) + Factor (dB)

Factor (dB) = Cable Loss (dB) + Antenna Factor (dB/m)

Site: AC 1	Time: 2015/09/19 - 14:53
Limit: FCC_Part15.209_RE(3m)	Engineer: Milo Li
Probe: BBHA9120D_1-18GHz	Polarity: Horizontal
EUT: Audio Conference Phone	Power: AC 120V/60Hz
Test Mode: Transmit at channel 2402MHz by 3DH5	

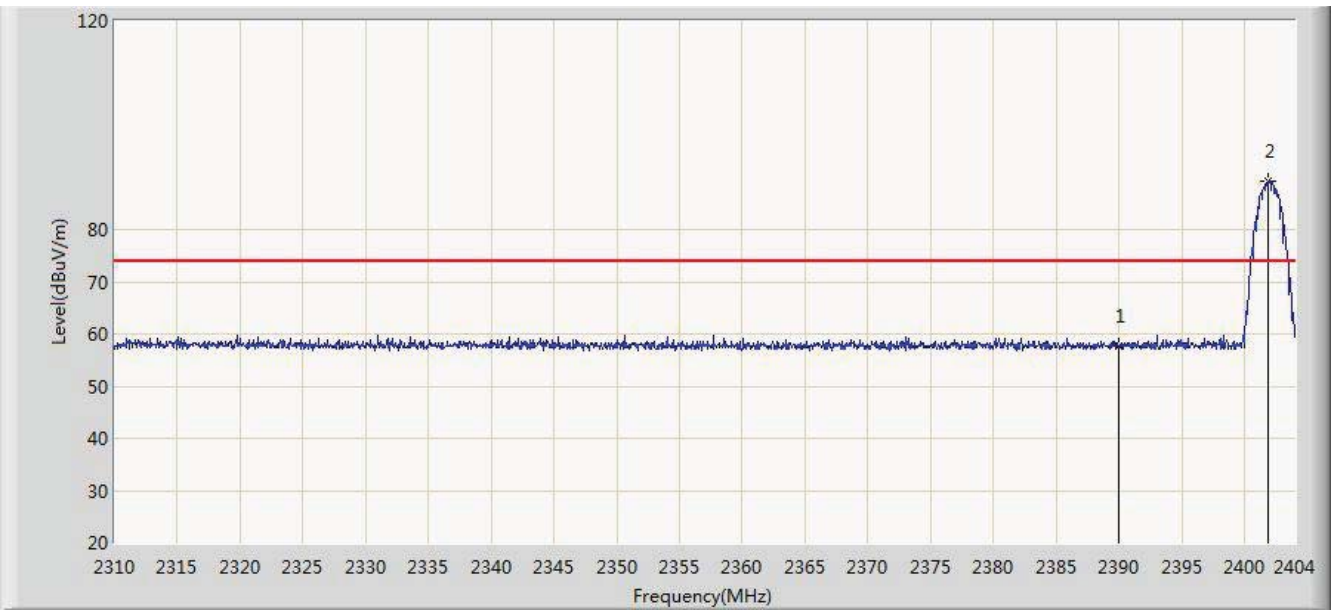

No	Flag	Mark	Frequency (MHz)	Measure Level (dBuV/m)	Reading Level (dBuV)	Over Limit (dB)	Limit (dBuV/m)	Factor (dB)	Type
1			2390.000	57.609	26.406	-16.391	74.000	31.203	PK
2		*	2401.885	89.174	57.990	N/A	N/A	31.184	PK

Note: Measure Level (dB $\mu$ V/m) = Reading Level (dB $\mu$ V) + Factor (dB)

Factor (dB) = Cable Loss (dB) + Antenna Factor (dB/m)

Site: AC 1	Time: 2015/09/19 - 14:55
Limit: FCC_Part15.209_RE(3m)	Engineer: Milo Li
Probe: BBHA9120D_1-18GHz	Polarity: Horizontal
EUT: Audio Conference Phone	Power: AC 120V/60Hz
Test Mode: Transmit at channel 2402MHz by 3DH5	

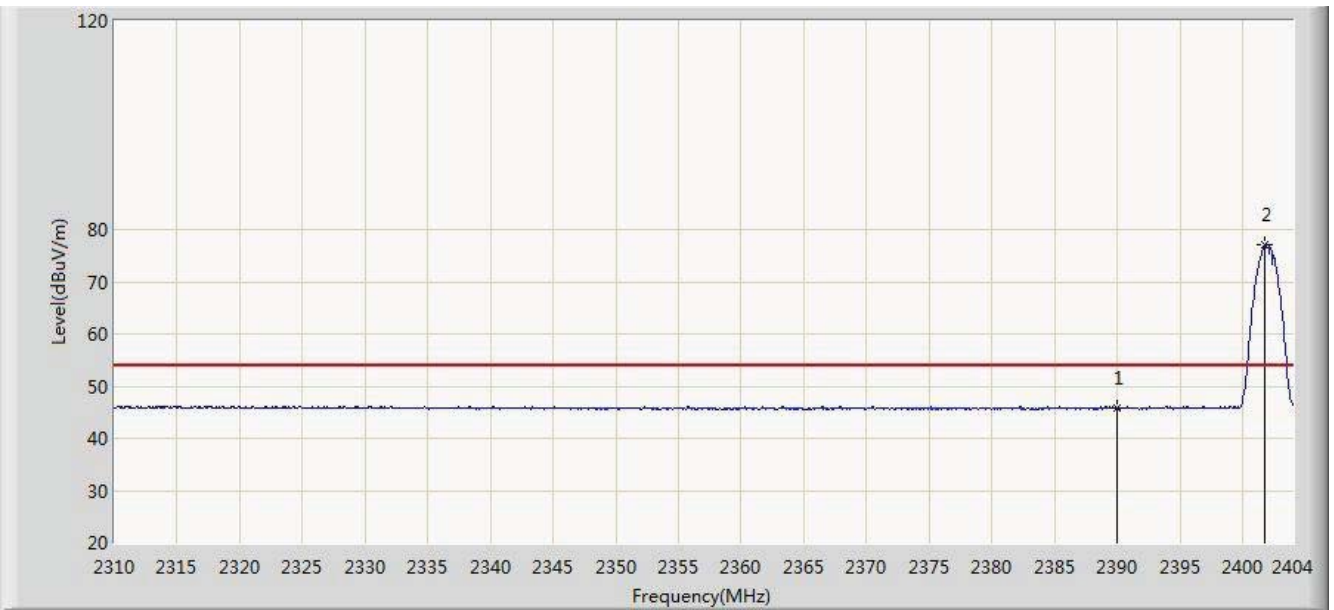

No	Flag	Mark	Frequency (MHz)	Measure Level (dBuV/m)	Reading Level (dBuV)	Over Limit (dB)	Limit (dBuV/m)	Factor (dB)	Type
1			2390.000	45.714	14.511	-8.286	54.000	31.203	AV
2		*	2401.791	77.035	45.851	N/A	N/A	31.184	AV

Note: Measure Level (dBμV/m) = Reading Level (dBμV) + Factor (dB)

Factor (dB) = Cable Loss (dB) + Antenna Factor (dB/m)

Site: AC 1	Time: 2015/09/19 - 14:55
Limit: FCC_Part15.209_RE(3m)	Engineer: Milo Li
Probe: BBHA9120D_1-18GHz	Polarity: Vertical
EUT: Audio Conference Phone	Power: AC 120V/60Hz
Test Mode: Transmit at channel 2402MHz by 3DH5	

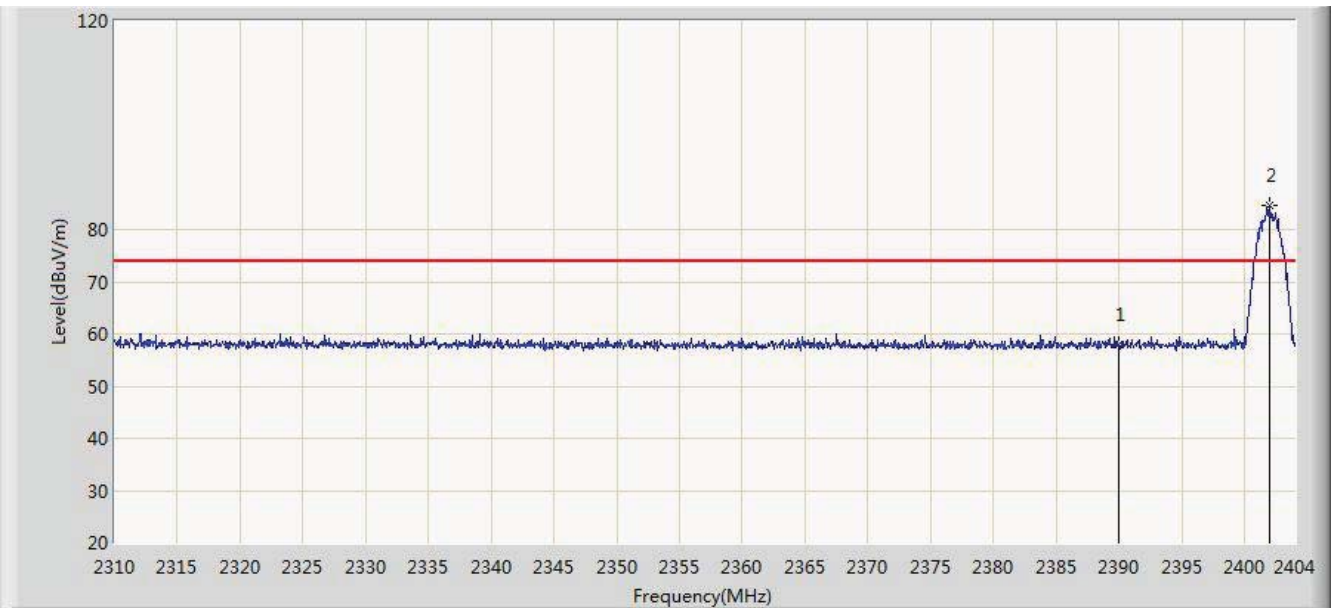

No	Flag	Mark	Frequency (MHz)	Measure Level (dBuV/m)	Reading Level (dBuV)	Over Limit (dB)	Limit (dBuV/m)	Factor (dB)	Type
1			2390.000	58.013	26.810	-15.987	74.000	31.203	PK
2		*	2401.979	84.643	53.459	N/A	N/A	31.184	PK

Note: Measure Level (dB $\mu$ V/m) = Reading Level (dB $\mu$ V) + Factor (dB)

Factor (dB) = Cable Loss (dB) + Antenna Factor (dB/m)

Site: AC 1	Time: 2015/09/19 - 14:57
Limit: FCC_Part15.209_RE(3m)	Engineer: Milo Li
Probe: BBHA9120D_1-18GHz	Polarity: Vertical
EUT: Audio Conference Phone	Power: AC 120V/60Hz
Test Mode: Transmit at channel 2402MHz by 3DH5	

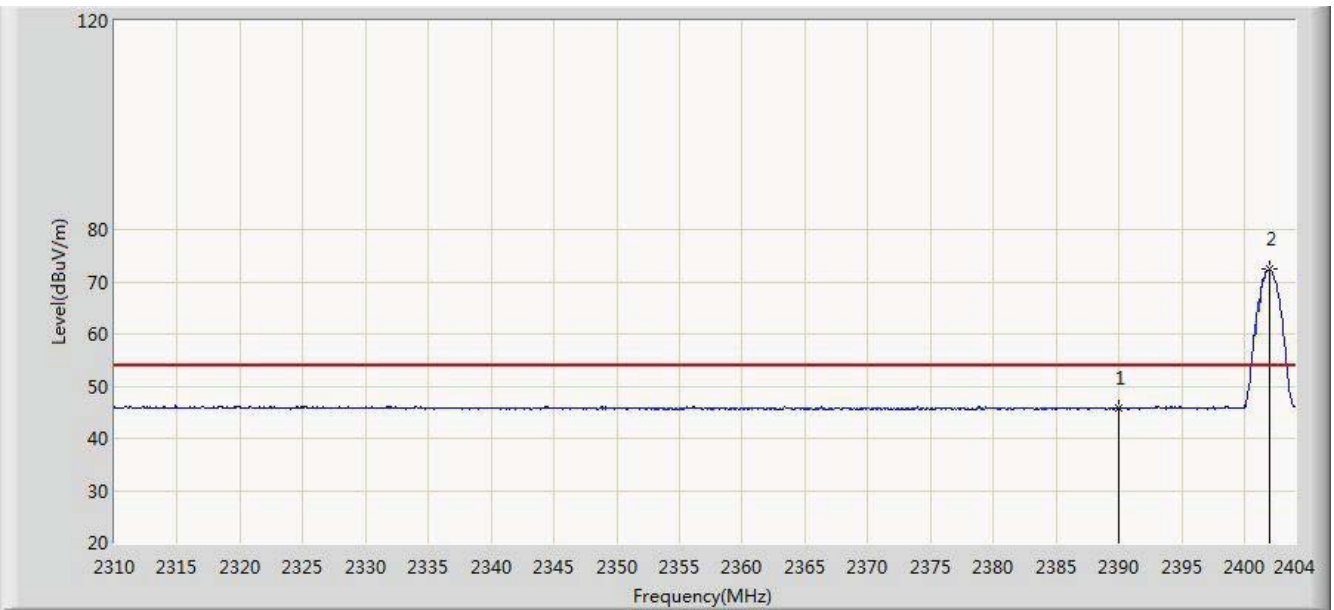

No	Flag	Mark	Frequency (MHz)	Measure Level (dBuV/m)	Reading Level (dBuV)	Over Limit (dB)	Limit (dBuV/m)	Factor (dB)	Type
1			2390.000	45.718	14.515	-8.282	54.000	31.203	AV
2		*	2401.979	72.380	41.196	N/A	N/A	31.184	AV

Note: Measure Level (dB $\mu$ V/m) = Reading Level (dB $\mu$ V) + Factor (dB)

Factor (dB) = Cable Loss (dB) + Antenna Factor (dB/m)



Site: AC 1	Time: 2015/09/19 - 14:58
Limit: FCC_Part15.209_RE(3m)	Engineer: Milo Li
Probe: BBHA9120D_1-18GHz	Polarity: Horizontal
EUT: Audio Conference Phone	Power: AC 120V/60Hz
Test Mode: Transmit at channel 2480MHz by 3DH5	

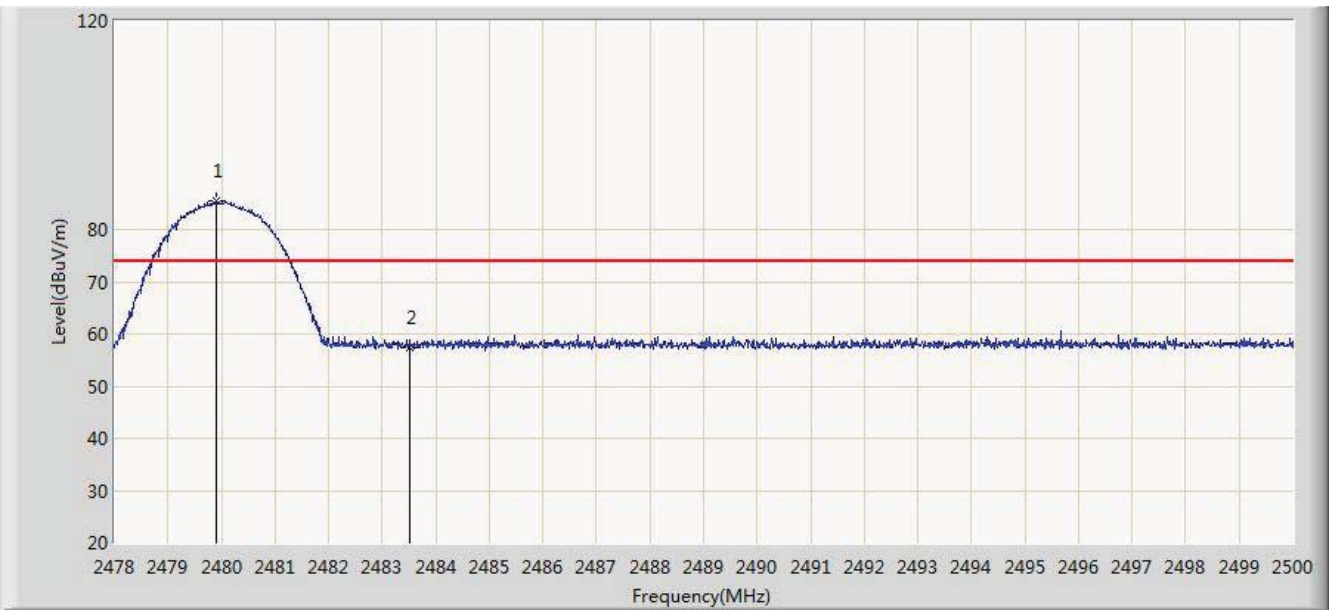

No	Flag	Mark	Frequency (MHz)	Measure Level (dBuV/m)	Reading Level (dBuV)	Over Limit (dB)	Limit (dBuV/m)	Factor (dB)	Type
1		*	2479.903	85.464	54.280	N/A	N/A	31.184	PK
2			2483.500	57.501	26.308	-16.499	74.000	31.194	PK

Note: Measure Level (dB $\mu$ V/m) = Reading Level (dB $\mu$ V) + Factor (dB)

Factor (dB) = Cable Loss (dB) + Antenna Factor (dB/m)

Site: AC 1	Time: 2015/09/19 - 15:00
Limit: FCC_Part15.209_RE(3m)	Engineer: Milo Li
Probe: BBHA9120D_1-18GHz	Polarity: Horizontal
EUT: Audio Conference Phone	Power: AC 120V/60Hz
Test Mode: Transmit at channel 2480MHz by 3DH5	

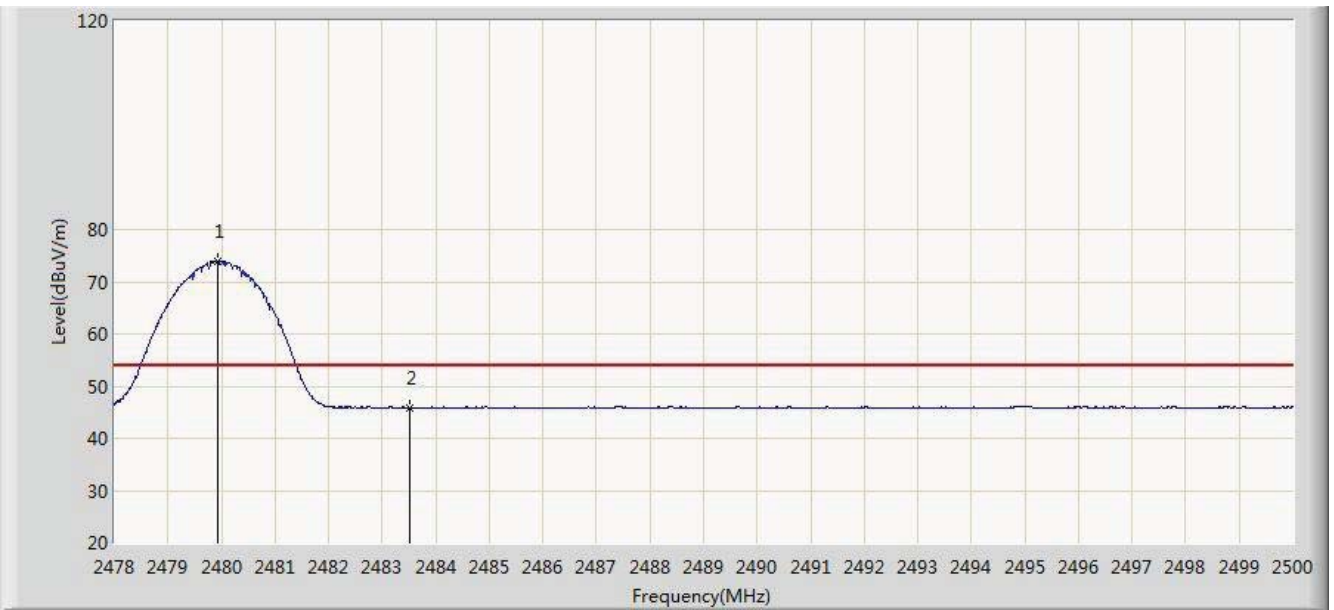

No	Flag	Mark	Frequency (MHz)	Measure Level (dBuV/m)	Reading Level (dBuV)	Over Limit (dB)	Limit (dBuV/m)	Factor (dB)	Type
1		*	2479.936	73.909	42.725	N/A	N/A	31.184	AV
2			2483.500	45.827	14.634	-8.173	54.000	31.194	AV

Note: Measure Level (dBμV/m) = Reading Level (dBμV) + Factor (dB)

Factor (dB) = Cable Loss (dB) + Antenna Factor (dB/m)

Site: AC 1	Time: 2015/09/19 - 15:00
Limit: FCC_Part15.209_RE(3m)	Engineer: Milo Li
Probe: BBHA9120D_1-18GHz	Polarity: Vertical
EUT: Audio Conference Phone	Power: AC 120V/60Hz
Test Mode: Transmit at channel 2480MHz by 3DH5	

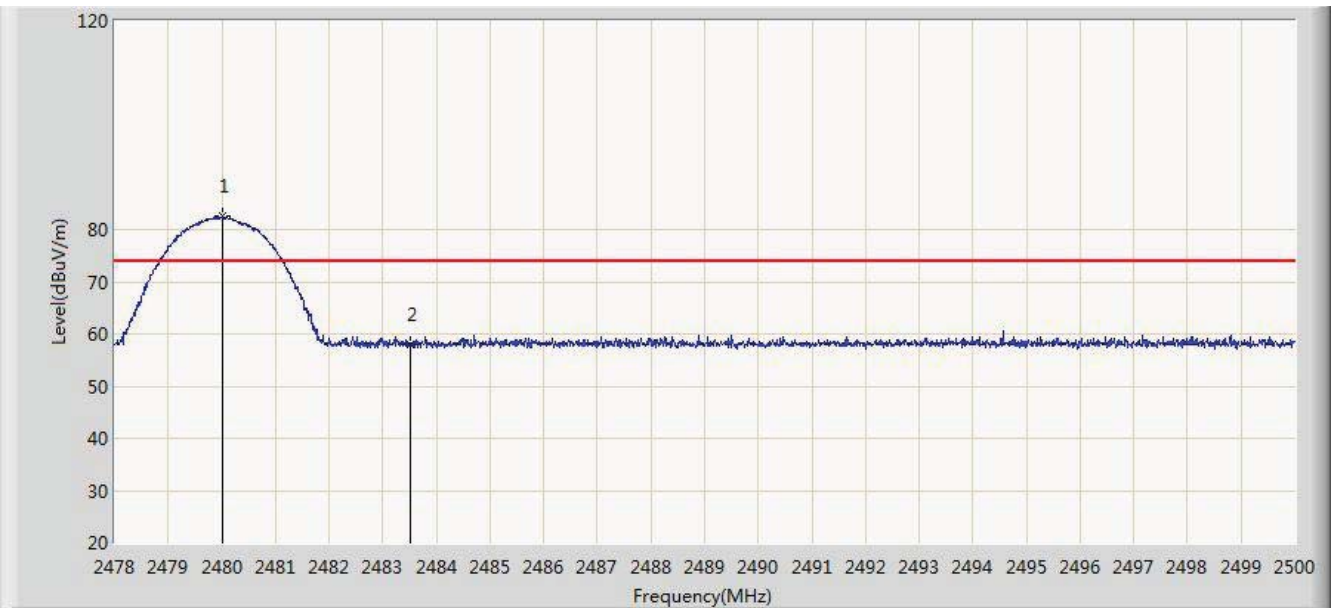

No	Flag	Mark	Frequency (MHz)	Measure Level (dBuV/m)	Reading Level (dBuV)	Over Limit (dB)	Limit (dBuV/m)	Factor (dB)	Type
1		*	2480.002	82.583	51.399	N/A	N/A	31.184	PK
2			2483.500	57.867	26.674	-16.133	74.000	31.194	PK

Note: Measure Level (dB $\mu$ V/m) = Reading Level (dB $\mu$ V) + Factor (dB)

Factor (dB) = Cable Loss (dB) + Antenna Factor (dB/m)

Site: AC 1	Time: 2015/09/19 - 15:03
Limit: FCC_Part15.209_RE(3m)	Engineer: Milo Li
Probe: BBHA9120D_1-18GHz	Polarity: Vertical
EUT: Audio Conference Phone	Power: AC 120V/60Hz
Test Mode: Transmit at channel 2480MHz by 3DH5	

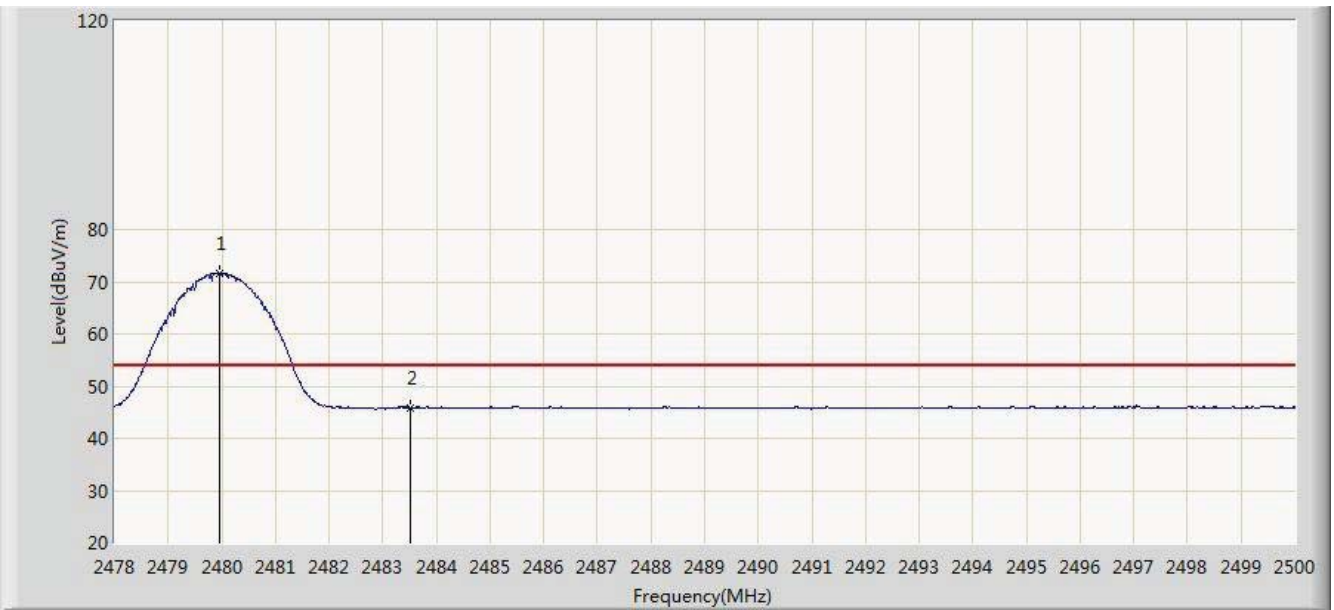

No	Flag	Mark	Frequency (MHz)	Measure Level (dBuV/m)	Reading Level (dBuV)	Over Limit (dB)	Limit (dBuV/m)	Factor (dB)	Type
1		*	2479.969	71.669	40.485	N/A	N/A	31.184	AV
2			2483.500	45.871	14.678	-8.129	54.000	31.194	AV

Note: Measure Level (dB $\mu$ V/m) = Reading Level (dB $\mu$ V) + Factor (dB)

Factor (dB) = Cable Loss (dB) + Antenna Factor (dB/m)

## 7.11. AC Conducted Emissions Measurement

### 7.11.1. Test Limit

FCC Part 15 Subpart C Paragraph 15.207 Limits		
Frequency (MHz)	QP (dB $\mu$ V)	Average (dB $\mu$ V)
0.15 - 0.50	66 - 56	56 - 46
0.50 - 5.0	56	46
5.0 - 30	60	50

Note 1: The lower limit shall apply at the transition frequencies.

Note 2: The limit decreases linearly with the logarithm of the frequency in the range 0.15MHz to 0.5MHz.

### 7.11.2. Test Setup

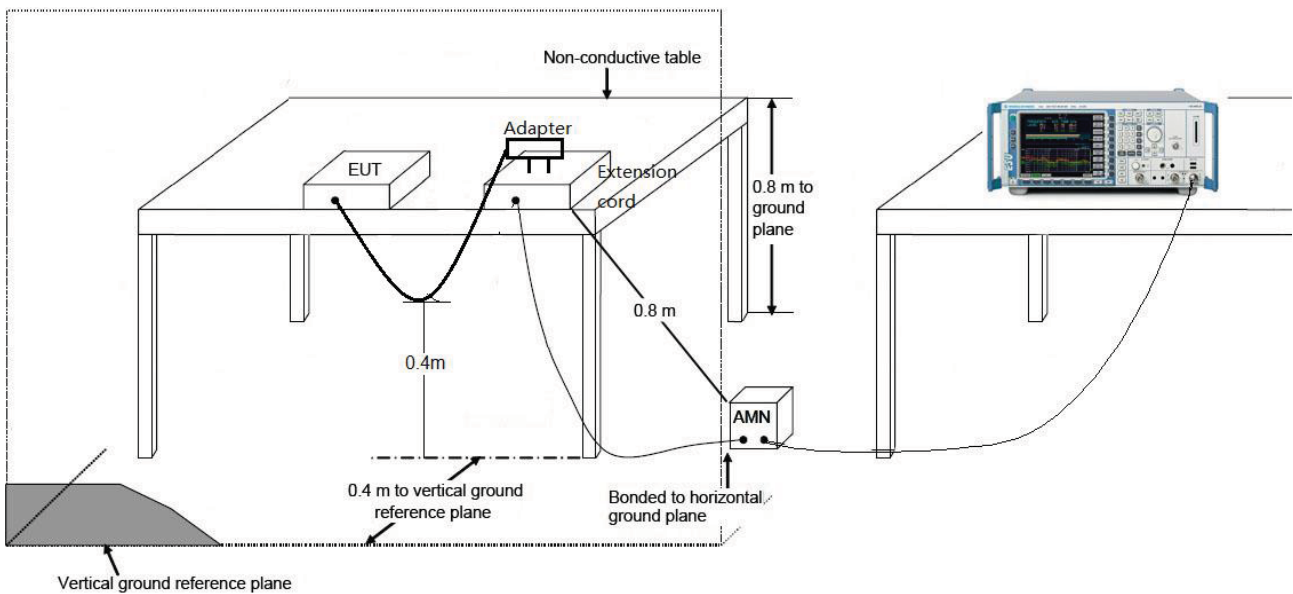

### 7.11.3. Test Result

Site: SR2	Time: 2015/09/26 - 15:38
Limit: FCC_Part15.207_CE_AC Power	Engineer: Line Chen
Probe: ENV216_101683_Filter On	Polarity: Line
EUT: Audio Conference Phone	Power: AC 120V/60Hz
Test Mode: Transmit at Channel 2480MHz by 2DH5 with Adapter 1#	

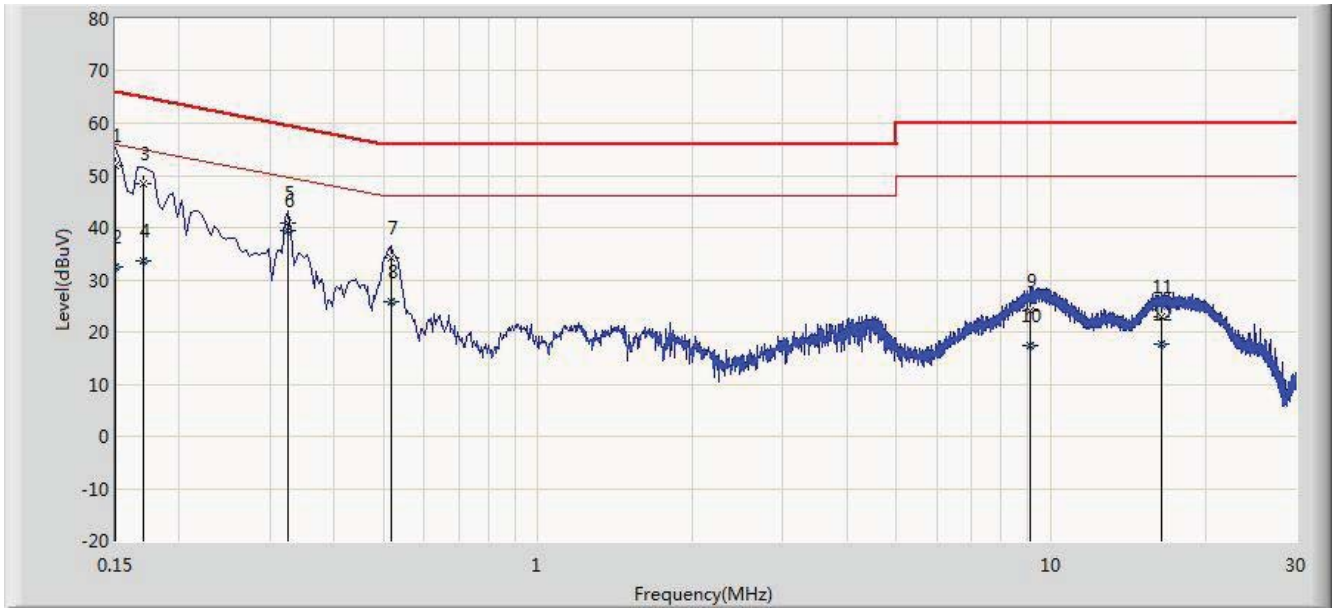

No	Flag	Mark	Frequency (MHz)	Measure Level (dBuV)	Reading Level (dBuV)	Over Limit (dB)	Limit (dBuV)	Factor (dB)	Type
1			0.150	52.021	40.853	-13.979	66.000	11.168	QP
2			0.150	32.369	21.200	-23.631	56.000	11.168	AV
3			0.170	48.434	38.357	-16.526	64.960	10.078	QP
4			0.170	33.562	23.485	-21.398	54.960	10.078	AV
5			0.326	40.766	30.741	-18.787	59.552	10.025	QP
6		*	0.326	39.449	29.425	-10.103	49.552	10.025	AV
7			0.518	34.284	24.128	-21.716	56.000	10.156	QP
8			0.518	25.824	15.668	-20.176	46.000	10.156	AV
9			9.134	23.951	13.785	-36.049	60.000	10.166	QP
10			9.134	17.347	7.181	-32.653	50.000	10.166	AV
11			16.458	22.853	12.778	-37.147	60.000	10.075	QP
12			16.458	17.704	7.629	-32.296	50.000	10.075	AV

Note: Measure Level (dBuV) = Reading Level (dBuV) + Factor (dB)

Factor (dB) = Cable Loss (dB) + LISN Factor (dB).

Site: SR2	Time: 2015/09/26 - 15:44
Limit: FCC_Part15.207_CE_AC Power	Engineer: Line Chen
Probe: ENV216_101683_Filter On	Polarity: Neutral
EUT: Audio Conference Phone	Power: AC 120V/60Hz
Test Mode: Transmit at Channel 2480MHz by 2DH5 with Adapter 1#	

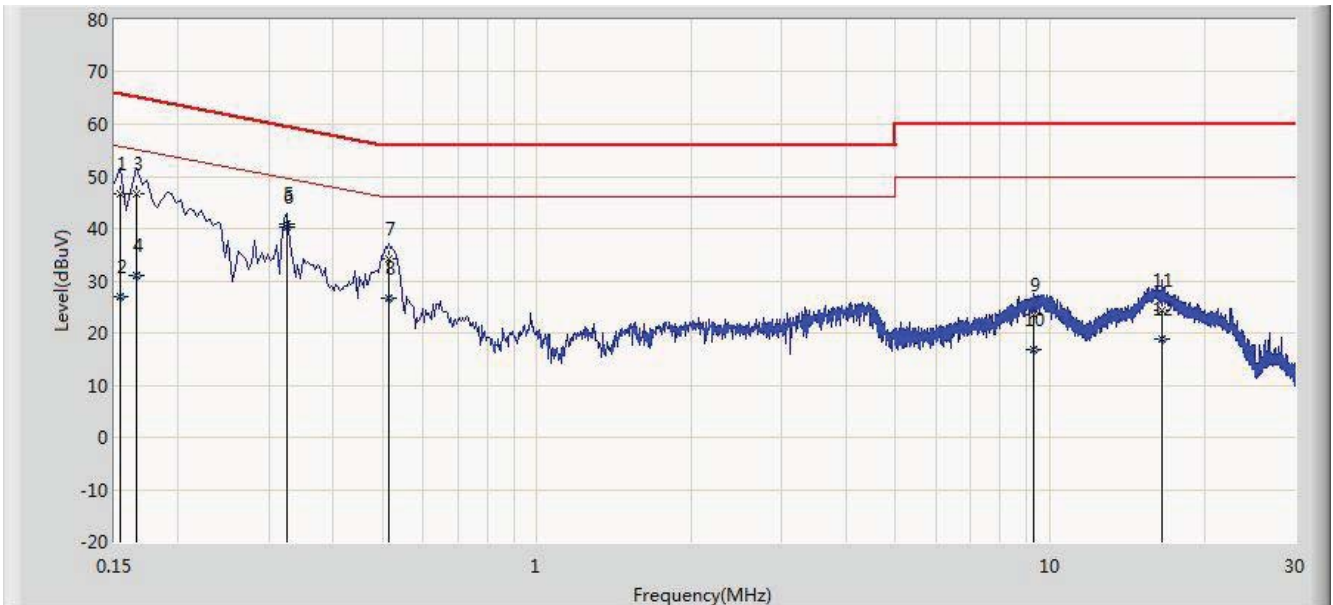

No	Flag	Mark	Frequency (MHz)	Measure Level (dBuV)	Reading Level (dBuV)	Over Limit (dB)	Limit (dBuV)	Factor (dB)	Type
1			0.154	46.660	35.944	-19.121	65.781	10.716	QP
2			0.154	26.935	16.219	-28.847	55.781	10.716	AV
3			0.166	46.670	36.599	-18.488	65.158	10.071	QP
4			0.166	31.095	21.023	-24.064	55.158	10.071	AV
5			0.326	40.836	30.780	-18.716	59.552	10.057	QP
6		*	0.326	40.321	30.264	-9.232	49.552	10.057	AV
7			0.514	34.239	24.064	-21.761	56.000	10.176	QP
8			0.514	26.714	16.538	-19.286	46.000	10.176	AV
9			9.306	23.469	13.297	-36.531	60.000	10.172	QP
10			9.306	16.796	6.624	-33.204	50.000	10.172	AV
11			16.566	24.407	14.287	-35.593	60.000	10.120	QP
12			16.566	18.968	8.848	-31.032	50.000	10.120	AV

Note: Measure Level (dBμV) = Reading Level (dBμV) + Factor (dB)

Factor (dB) = Cable Loss (dB) + LISN Factor (dB).

## 8. CONCLUSION

The data collected relate only the item(s) tested and show that the **Audio Conference Phone FCC ID: YZZGAC2500** is in compliance with Part 15C of the FCC Rules.

---

The End