

# TEST REPORT

of

FCC Part 2 Subpart J, Part 22 Subpart C/H,  
Part 24 Subpart E, Part 27 Subpart C  
IC RSS-Gen Issue 5, RSS-130 Issue 2, RSS-132 Issue 4,  
RSS-133 Issue 6, RSS-139 Issue 4 and RSS-199 Issue 4

FCC ID: YZP-VL4000  
IC Certification: 7414C-VL4000

Equipment Under Test : Telematics Module  
Model Name : LTD-VL4000  
Variant Model Name(s) : -  
Applicant : FCC: LG Innotek Co., Ltd.  
: IC: LG Innotek Co., Ltd.  
Manufacturer : LG Innotek Co., Ltd.  
Date of Receipt : 2024.02.20  
Date of Test(s) : 2024.03.06 ~ 2024.04.04  
Date of Issue : 2024.04.15

In the configuration tested, the EUT complied with the standards specified above. This test report does not assure KOLAS accreditation.

- 1) The results of this test report are effective only to the items tested.
- 2) The SGS Korea is not responsible for the sampling, the results of this test report apply to the sample as received.
- 3) This test report cannot be reproduced, except in full, without prior written permission of the Company.
- 4) The data marked ※ in this report was provided by the customer and may affect the validity of the test results.

We are responsible for all the information of this test report except for the data(※) provided by the customer.

Tested by:

  
Inho Park

Technical  
Manager:



Jinhyoung Cho

**SGS Korea Co., Ltd. Gunpo Laboratory**

# INDEX

<u>Table of Contents</u>	Page
1. General Information -----	3
2. E.R.P. / E.I.R.P. & Radiated Spurious Emissions -----	11
3. Conducted Output Power -----	25
4. Occupied Bandwidth -----	37
5. Peak-Average Ratio -----	51
6. Spurious Emissions at Antenna Terminal -----	68
7. Band Edge and Emission Mask -----	78
8. Frequency Stability -----	138

## 1. General Information

### 1.1. Testing Laboratory

SGS Korea Co., Ltd. (Gunpo Laboratory)  
 - 10-2, LS-ro 182beon-gil, Gunpo-si, Gyeonggi-do, Korea, 15807  
 - 4, LS-ro 182beon-gil, Gunpo-si, Gyeonggi-do, Korea, 15807  
 - Designation number: KR0150

All SGS services are rendered in accordance with the applicable SGS conditions of service available on request and accessible at <http://www.sgs.com/en/Terms-and-Conditions.aspx>.

Phone No. : +82 31 688 0901  
 Fax No. : +82 31 688 0921

### 1.2. Details of Applicant

Applicant : LG Innotek Co., Ltd.  
 Address : 30, Magokjungang 10-ro, Gangseo-gu, Seoul, Korea, 07796  
 Contact Person : Jeong, In-chang  
 Phone No. : +82 62 950 0332

### 1.3. Details of Manufacturer

Company : LG Innotek Co., Ltd.  
 Address : 30, Magokjungang 10-ro, Gangseo-gu, Seoul, Korea, 07796  
 Factory 1 : LG Innotek Co., Ltd.  
 Factory 1 Address : 26, Hanamsandan 5beon-ro, Gwangsan-gu, Gwangju, Republic of Korea, 62229  
 Factory 2 : PT. LG INNOTEK INDONESIA  
 Factory 2 Address : Bekasi International Industrial Estate, Blok C8 No.12 & 12A,  
 Desa Cibatu, Cikarang Selatan, Bekasi 17750, Jawa Barat - Indonesia

### 1.4. Description of EUT

<b>Kind of Product</b>	Telematics Module
<b>Model Name</b>	LTD-VL4000
<b>Serial Number</b>	Conducted: C-01 Radiated: R-01
<b>Power Supply</b>	DC 4.0 V
<b>Rated Power</b>	LTE Band 2, 4, 5, 7, 12, 13, 17, 66: 23 dB m
<b>Frequency Range</b>	LTE Band 2: 1 850 MHz ~ 1 910 MHz LTE Band 4: 1 710 MHz ~ 1 755 MHz LTE Band 5: 824 MHz ~ 849 MHz LTE Band 7: 2 500 MHz ~ 2 570 MHz LTE Band 12: 699 MHz ~ 716 MHz LTE Band 13: 777 MHz ~ 787 MHz LTE Band 17: 704 MHz ~ 716 MHz LTE Band 66: 1 710 MHz ~ 1 780 MHz
<b>Modulation Technique</b>	QPSK, 16QAM
<b>Antenna Type</b>	Dipole Antenna
<b>Antenna Gain*</b>	Refer to the clause 1.13
<b>H/W Version</b>	Rev 0
<b>S/W Version</b>	01B_D20SKU1
<b>FVIN</b>	N/A

### 1.5. Test Equipment List

Equipment	Manufacturer	Model	S/N	Cal. Date	Cal. Interval	Cal. Due
Signal Generator	R&S	SMA100B	106887	Oct. 06, 2023	Annual	Oct. 06, 2024
Spectrum Analyzer	R&S	FSV30	103454	Dec. 01, 2023	Annual	Dec. 01, 2024
Spectrum Analyzer	Agilent	N9020A	MY53421758	Sep. 01, 2023	Annual	Sep. 01, 2024
Spectrum Analyzer	Agilent	N9030A	US51350132	Nov. 27, 2023	Annual	Nov. 27, 2024
Communication Analyzer	Anritsu	MT8821C	6262192291	Feb. 08, 2024	Annual	Feb. 08, 2025
Power Meter	Anritsu	ML2495A	1223004	May 30, 2023	Annual	May 30, 2024
Power Sensor	Anritsu	MA2411B	1207272	May 30, 2023	Annual	May 30, 2024
Temperature Chamber	ESPEC CORP.	PL-2J	15004189	Jun. 01, 2023	Annual	Jun. 01, 2024
Low Pass Filter	Mini-Circuits	NLP-1200+	V 8979400903-1	May 16, 2023	Annual	May 16, 2024
High Pass Filter	Wainwright Instrument GmbH	WHKX10-900-1000-18000-40SS	7	Feb. 27, 2024	Annual	Feb. 27, 2025
High Pass Filter	Wainwright Instrument GmbH	WHKX3.0/18G-10SS	21	Jun. 01, 2023	Annual	Jun. 01, 2024
High Pass Filter	Wainwright Instrument GmbH	WHNX7.5/26.5G-6SS	11	Oct. 17, 2023	Annual	Oct. 17, 2024
BRIDGE COUPLER	MARKI MICROWAVE INC	CBR16-0012	1542	May 16, 2023	Annual	May 16, 2024
Directional Coupler	KRYTAR	152613	122661	Feb. 27, 2024	Annual	Feb. 27, 2025
DC Power Supply	R&S	HMP2020	20089489	May 11, 2023	Annual	May 11, 2024
Preamplifier	H.P.	8447F	2944A03909	Aug. 04, 2023	Annual	Aug. 04, 2024
Preamplifier	R&S	SCU18F	101058	Dec. 07, 2023	Annual	Dec. 07, 2024
Preamplifier	MITEQ Inc.	JS44-18004000-35-8P	1546891	Oct. 06, 2023	Annual	Oct. 06, 2024
Test Receiver	R&S	ESU26	100109	Jan. 16, 2024	Annual	Jan. 16, 2025
Loop Antenna	Schwarzbeck Mess-Elektronik	FMZB 1519	1519-039	Aug. 21, 2023	Biennial	Aug. 21, 2025
Bilog Antenna	Schwarzbeck Mess-Elektronik	VULB9163	9163-437	May 31, 2023	Biennial	May 31, 2025
Horn Antenna	R&S	HF906	100326	Feb. 19, 2024	Annual	Feb. 19, 2025
Horn Antenna	Schwarzbeck Mess-Elektronik	BBHA 9170	9170-540	Dec. 05, 2023	Annual	Dec. 05, 2024
Antenna Master	Innco systems GmbH	MA4640-XP-ET	MA4640/536/383 30516/L	N.C.R.	N/A	N.C.R.
Turn Table	Innco systems GmbH	DS 1200S	N/A	N.C.R.	N/A	N.C.R.
Controller	Innco systems GmbH	CONTROLLER CO3000-4P	CO3000/963/383 30516/L	N.C.R.	N/A	N.C.R.
Anechoic Chamber	SY Corporation	L x W x H (9.6 m x 6.4 m x 6.6 m)	N/A	N.C.R.	N/A	N.C.R.
Coaxial Cable	RFONE	MWX221-NMSNMS (4 m)	J1023142	Oct. 04, 2023	Semi-Annual	Apr. 04, 2024
Coaxial Cable	Qualwave Inc.	QA500-18-NN-10 (10 m)	22200114	Oct. 04, 2023	Semi-Annual	Apr. 04, 2024
Coaxial Cable	RADIALL	TESTPRO 3	182287	Oct. 14, 2023	Semi-Annual	Apr. 14, 2024
Coaxial Cable	RADIALL	TESTPRO 3	182288	Oct. 14, 2023	Semi-Annual	Apr. 14, 2024
Coaxial Cable	RADIALL	TESTPRO 3	182291	Oct. 14, 2023	Semi-Annual	Apr. 14, 2024

**Note;**

For equipment listed above that has a calibration date or calibration due date that falls within the test date range, care was taken to ensure that this equipment was used after the calibration date and before the calibration due date.

### 1.6. Summary of Test Results

The EUT has been tested according to the following specifications:

<b>APPLIED STANDARD: FCC Part 2, 22, 24 and 27 IC RSS-Gen Issue 5, RSS-130 Issue 2, RSS-132 Issue 4, RSS-133 Issue 6, RSS-139 Issue 4 and RSS-199 Issue 4</b>			
Section in FCC	Section in IC	Test Item(s)	Result
§2.1046 §22.913(a)(5) §24.232(c) §27.50(b)(9) §27.50(c)(9) §27.50(d)(4) §27.50(h)(2)	RSS-130 Issue 2 4.6 RSS-132 Issue 4 5.4 RSS-133 Issue 6 6.4 RSS-139 Issue 4 5.5 RSS-199 Issue 4 5.5	E.R.P. / E.I.R.P.	Complied
§22.917(a) §24.238(a) §27.53(c)(2) §27.53(f) §27.53(g) §27.53(h)(1) §27.53(m)(4)	RSS-130 Issue 2 4.7 RSS-132 Issue 4 5.5 RSS-133 Issue 6 6.5 RSS-139 Issue 4 5.6 RSS-199 Issue 4 5.6	Radiated Spurious Emissions	Complied
§2.1046	RSS-Gen Issue 5 6.12	Conducted Output Power	Complied
§2.1049	RSS-Gen Issue 5 6.7	Occupied Bandwidth	Complied
§22.913(d) §24.232(d) §27.50(d)(5)	RSS-130 Issue 2 4.6 RSS-132 Issue 4 5.4 RSS-133 Issue 6 6.4 RSS-139 Issue 4 5.5 RSS-199 Issue 4 5.5	Peak-Average Ratio	Complied
§22.917(a) §24.238(a) §27.53(c)(2) §27.53(g) §27.53(h)(1) §27.53(m)(4)	RSS-130 Issue 2 4.7 RSS-132 Issue 4 5.5 RSS-133 Issue 6 6.5 RSS-139 Issue 4 5.6 RSS-199 Issue 4 5.6	Spurious Emission at Antenna Terminal	Complied
§22.917(a) §24.238(a) §27.53(c)(2)(4) §27.53(g) §27.53(h)(1) §27.53(m)(4)	RSS-130 Issue 2 4.7 RSS-132 Issue 4 5.5 RSS-133 Issue 6 6.5 RSS-139 Issue 4 5.6 RSS-199 Issue 4 5.6	Band Edge and Emission Mask	Complied
§2.1055 §22.355 §24.235 §27.54	RSS-Gen Issue 5 6.11 RSS-130 Issue 2 4.5 RSS-132 Issue 4 5.3 RSS-133 Issue 6 6.3 RSS-139 Issue 4 5.4 RSS-199 Issue 4 5.4	Frequency Stability	Complied

## 1.7. Sample Calculation for Offset

Where relevant, the following sample calculation is provided:

### 1.7.1. Conducted Test

Offset value (dB) = Directional Coupler (dB) + Cable loss (dB)

### 1.7.2. Radiation test

- E.I.R.P. (dB m) = Measured level (dB $\mu$ V) + Antenna factor (dB/m) + Cable loss (dB) + 20 Log D - 104.8;  
where D is the measurement distance in meters.
- E.R.P. (dB m) = E.I.R.P. (dB m) - 2.15 (dB)

## 1.8. Device Capabilities

This device contains the following capabilities;

LTE Band 4 (1 710 MHz ~ 1 755 MHz) is covered by LTE Band 66 (1 710 MHz ~ 1 780 MHz) due to overlapping frequency range, same maximum tune-up limit and same channel bandwidth. Therefore test data provided in this report covers LTE Band 4 as well as Band 66.

LTE Band 17 (704 MHz ~ 716 MHz) is covered by LTE Band 12 (699 MHz ~ 716 MHz) due to overlapping frequency range, same maximum tune-up limit and same channel bandwidth. Therefore test data provided in this report covers LTE Band 17 as well as Band 12.

## 1.9. Worst Case Configuration and Mode

The worst-case is based on the conducted output power measurement investigation results.

Output power measurements were measured on QPSK and 16QAM modulations.

All testing was performed using QPSK and 16QAM modulations. However, the spurious radiated emission and spurious at antenna terminal were only performed on bandwidth and RB offset (with RB size 1) with the highest conducted power in QPSK. The peak to average ratio were tested only 16QAM modulation as worst case.

The radiation test of the EUT was investigated in three orthogonal orientations X, Y, and Z, and the worst case data is reported.

### 1.10. Measurement Configuration

Test Items	Band	Test Channel			Bandwidth (MHz)						Modulation		RB #		
		Low	Mid	High	1.4	3	5	10	15	20	QPSK	16QAM	1	Half	Full
Conducted Output Power	2	V	V	V	V	V	V	V	V	V	V	V	V	V	V
	66/4	V	V	V	V	V	V	V	V	V	V	V	V	V	V
	5	V	V	V	V	V	V	V			V	V	V	V	V
	7	V	V	V			V	V	V	V	V	V	V	V	V
	*12/17	V	V	V	V	V	V	V			V	V	V	V	V
	13	V	V	V			V	V			V	V	V	V	V
Frequency Stability	2	-	V	-	-	-	V	-	-	-	V	-	-	-	V
	66/4	-	V	-	-	-	V	-	-	-	V	-	-	-	V
	5	-	V	-	-	-	V	-			V	-	-	-	V
	7	-	V	-			V	-	-	-	V	-	-	-	V
	*12/17	-	V	-	-	-	V	-			V	-	-	-	V
	13	-	V	-			V	-			V	-	-	-	V
Occupied Bandwidth	2	-	V	-	V	V	V	V	V	V	V	V	-	-	V
	66/4	-	V	-	V	V	V	V	V	V	V	V	-	-	V
	5	-	V	-	V	V	V	V			V	V	-	-	V
	7	-	V	-			V	V	V	V	V	V	-	-	V
	*12/17	-	V	-	V	V	V	V			V	V	-	-	V
	13	-	V	-			V	V			V	V	-	-	V
Peak-to-Average Ratio	2	V	V	V	V	V	V	V	V	V	-	V	-	-	V
	66/4	V	V	V	V	V	V	V	V	V	-	V	-	-	V
	5	V	V	V	V	V	V	V			-	V	-	-	V
	7	V	V	V			V	V	V	V	-	V	-	-	V
	*12/17	V	V	V	V	V	V	V			-	V	-	-	V
	13	V	V	V			V	V			-	V	-	-	V
Band edge	2	V	V	V	V	V	V	V	V	V	V	V	V	-	V
	66/4	V	V	V	V	V	V	V	V	V	V	V	V	-	V
	5	V	V	V	V	V	V	V			V	V	V	-	V
	7	V	V	V			V	V	V	V	V	V	V	-	V
	*12/17	V	V	V	V	V	V	V			V	V	V	-	V
	13	V	V	V			V	V			V	V	V	-	V
Spurious at antenna terminal & Radiated Spurious Emissions	2	V	V	V	Worst case										
	66/4	V	V	V	Worst case										
	5	V	V	V	Worst case										
	7	V	V	V	Worst case										
	*12/17	V	V	V	Worst case										
	13	V	V	V	Worst case										

\*B17 is not supported 1.4M/3M bandwidth.

### 1.11. Measurement Uncertainty

Where relevant, the following measurement uncertainty levels have been estimated for tests performed on the apparatus:

Parameter	Uncertainty	
Conducted Output Power	0.33 dB	
Occupied Bandwidth	0.05 MHz	
Conducted Spurious Emissions	0.99 dB	
Peak to Average Ratio	0.66 dB	
Frequency Stability	116 Hz	
Radiated Emission, 9 kHz to 30 MHz	H	3.60 dB
	V	3.60 dB
Radiated Emission, below 1 GHz	H	4.60 dB
	V	4.90 dB
Radiated Emission, above 1 GHz	H	3.90 dB
	V	3.80 dB

All measurement uncertainty values are shown with a coverage factor of  $k=2$  to indicate a 95 % level of confidence.

### 1.12. Test Report Revision

Revision	Report Number	Date of Issue	Description
0	F690501-RF-RTL004965	2024.04.15	Initial

### 1.13. Antenna Information

Band	Operating Frequency (MHz)	Antenna Peak Gain (dB i)
LTE 2	1 850 ~ 1 910	5.97
LTE 66/4	1 710 ~ 1 780	4.13
LTE 5	824 ~ 849	2.18
LTE 7	2 500 ~ 2 570	3.97
LTE 12/17	699 ~ 716	-1.74
LTE 13	777 ~ 787	-0.24



### 1.14. Emission Designator and Max Power

Band	Band width (MHz)	Modulation	Low Freq. (MHz)	Upper Freq. (MHz)	Conducted Average (dB m)	Ant. Gain (dB i)	E.R.P. / E.I.R.P. Average (dB m)	E.R.P. / E.I.R.P. Average (W)	Emission Designator		
2	1.4	QPSK	1 850.7	1 909.3	22.54	5.97	28.51	0.710	1M09G7D		
		16QAM			21.90		27.87	0.612	1M09D7D		
	3	QPSK	1 851.5	1 908.5	22.53		28.50	0.708	2M67G7D		
		16QAM			21.87		27.84	0.608	2M68D7D		
	5	QPSK	1 852.5	1 907.5	22.62		28.59	0.723	4M50G7D		
		16QAM			21.91		27.88	0.614	4M51D7D		
	10	QPSK	1 855.0	1 905.0	22.59		28.56	0.718	8M93G7D		
		16QAM			21.87		27.84	0.608	8M93D7D		
	15	QPSK	1 857.5	1 902.5	22.66		28.63	0.729	13M4G7D		
		16QAM			21.97		27.94	0.622	13M5D7D		
	20	QPSK	1 860.0	1 900.0	22.61		28.58	0.721	17M9G7D		
		16QAM			21.82		27.79	0.601	17M9D7D		
	66/4	1.4	QPSK	1 710.7	1 779.3		22.39	4.13	26.52	0.449	1M09G7D
			16QAM				21.70		25.83	0.383	1M09D7D
3		QPSK	1 711.5	1 778.5	22.47	26.60	0.457		2M67G7D		
		16QAM			21.76	25.89	0.388		2M68D7D		
5		QPSK	1 712.5	1 777.5	22.38	26.51	0.448		4M49G7D		
		16QAM			21.79	25.92	0.391		4M48D7D		
10		QPSK	1 715.0	1 775.0	22.66	26.79	0.478		8M95G7D		
		16QAM			21.74	25.87	0.386		8M93D7D		
15		QPSK	1 717.5	1 772.5	22.63	26.76	0.474		13M4G7D		
		16QAM			21.94	26.07	0.405		13M4D7D		
20		QPSK	1 720.0	1 770.0	22.56	26.69	0.467		17M9G7D		
		16QAM			21.94	26.07	0.405		17M9D7D		
5		1.4	QPSK	824.7	848.3	22.62	2.18		22.65	0.184	1M09G7D
			16QAM			21.90			21.93	0.156	1M09D7D
	3	QPSK	825.5	847.5	22.90	22.93		0.196	2M67G7D		
		16QAM			22.20	22.23		0.167	2M67D7D		
	5	QPSK	826.5	846.5	22.79	22.82		0.191	4M50G7D		
		16QAM			22.09	22.12		0.163	4M50D7D		
	10	QPSK	829.0	844.0	22.59	22.62		0.183	8M95G7D		
		16QAM			21.87	21.90		0.155	8M93D7D		
	7	5	QPSK	2 502.5	2 567.5	22.49		3.97	26.46	0.443	4M50G7D
			16QAM			21.76			25.73	0.374	4M50D7D
10		QPSK	2 505.0	2 565.0	22.47	26.44	0.441		8M93G7D		
		16QAM			21.81	25.78	0.378		8M91D7D		
15		QPSK	2 507.5	2 562.5	22.65	26.62	0.459		13M4G7D		
		16QAM			21.92	25.89	0.388		13M5D7D		
20		QPSK	2 510.0	2 560.0	22.70	26.67	0.465		17M9G7D		
		16QAM			22.00	25.97	0.395		17M9D7D		

Band	Band width (MHz)	Modulation	Low Freq. (MHz)	Upper Freq. (MHz)	Conducted Average (dB m)	Ant. Gain (dB i)	E.R.P. / E.I.R.P. Average (dB m)	E.R.P. / E.I.R.P. Average (W)	Emission Designator
12	1.4	QPSK	699.7	715.3	22.21	-1.74	18.32	0.068	1M09G7D
		16QAM			21.27		17.38	0.055	1M09D7D
	3	QPSK	700.5	714.5	22.14		18.25	0.067	2M67G7D
		16QAM			21.45		17.56	0.057	2M68D7D
12/17	5	QPSK	701.5	713.5	22.08		18.19	0.066	4M50G7D
		16QAM			21.34		17.45	0.056	4M51D7D
	10	QPSK	704.0	711.0	22.12		18.23	0.067	8M97G7D
		16QAM			21.38		17.49	0.056	8M93D7D
13	5	QPSK	779.5	784.5	22.05	-0.24	19.66	0.092	4M51G7D
		16QAM			21.17		18.78	0.076	4M49D7D
	10	QPSK	782.0	782.0	22.04		19.65	0.092	8M91G7D
		16QAM			21.20		18.81	0.076	8M91D7D

## 2. E.R.P. / E.I.R.P. & Radiated Spurious Emissions

### 2.1. Test setup

The diagram below shows the test setup that is utilized to make the measurements for emission from 9 kHz to 30 MHz.

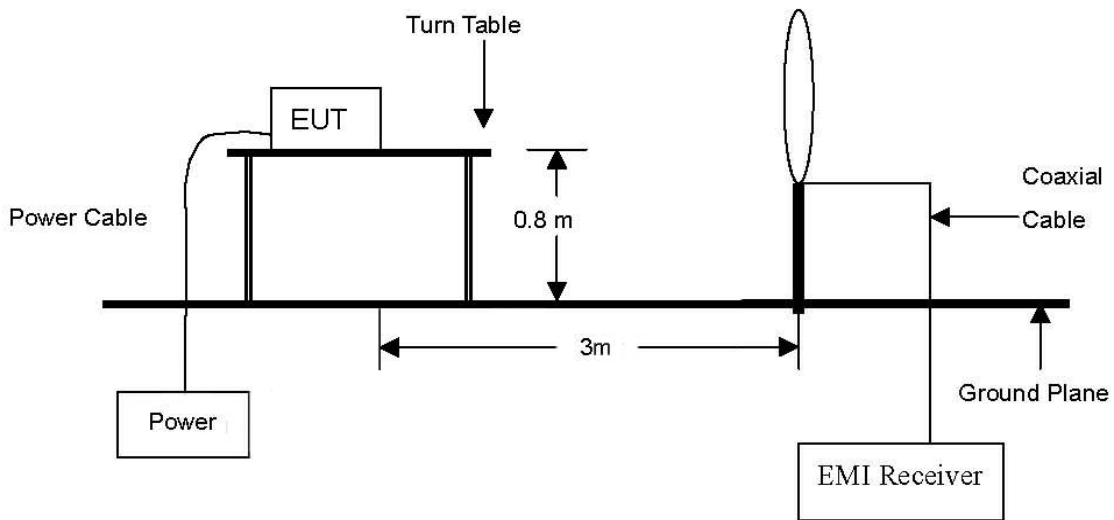

The diagram below shows the test setup that is utilized to make the measurements for emission from 30 MHz to 1 GHz Emissions.

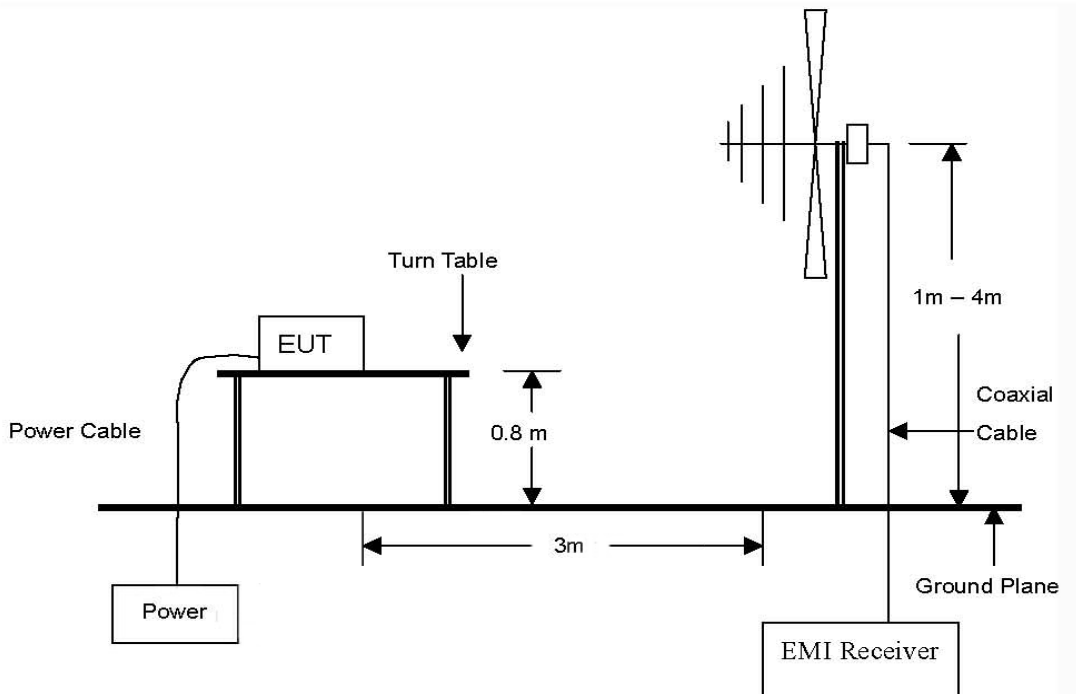

The diagram below shows the test setup that is utilized to make the measurements for emission from 1 GHz to 26 GHz Emissions.

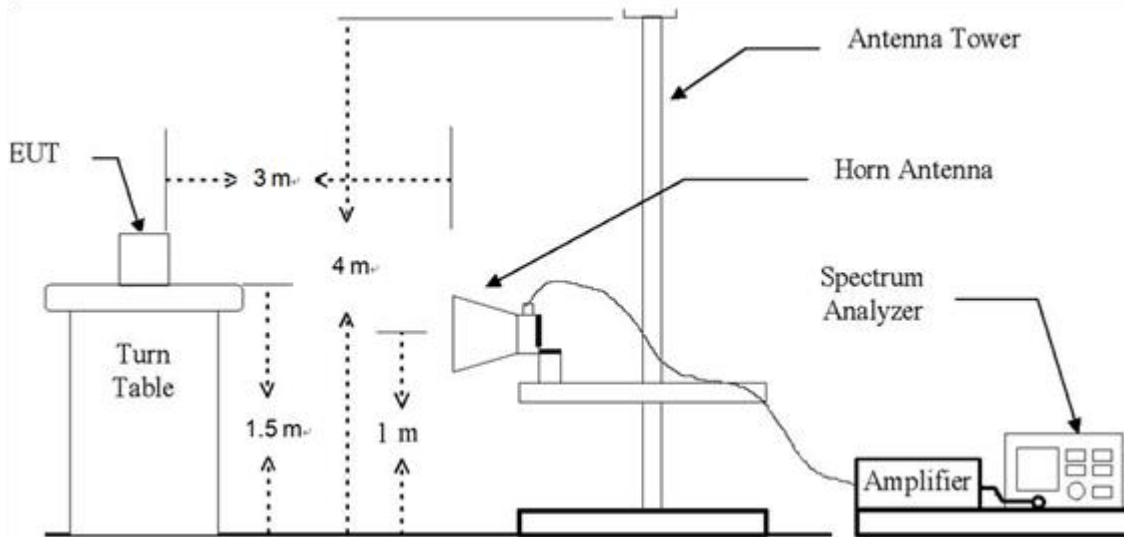

## 2.2. Limit

### 2.2.1. Limit of E.R.P. / E.I.R.P.

#### FCC

- §22.913(a)(5), the ERP of mobile transmitters and auxiliary test transmitters must not exceed 7 watts.
- §24.232(c), mobile and portable stations are limited to 2 watts EIRP and the equipment must employ a means for limiting power to the minimum necessary for successful communications.
- §27.50(b)(9), control stations and mobile stations transmitting in the 746-757 MHz, 776-788 MHz, and 805-806 MHz bands and fixed stations transmitting in the 787-788 MHz and 805-806 MHz bands are limited to 30 watts ERP.
- §27.50(c)(9), control and mobile stations in the 698-746 MHz band are limited to 30 watts ERP.
- §27.50(d)(4), fixed, mobile, and portable (hand-held) stations operating in the 1 710-1 755 MHz band and mobile and portable stations operating in the 1 695-1 710 MHz and 1 755-1 780 MHz bands are limited to 1 watt EIRP.
- §27.50(h)(2), Mobile and other user stations. Mobile stations are limited to 2.0 watts EIRP. All user stations are limited to 2.0 watts transmitter output power.

#### IC

- RSS-130 Issue 2  
 4.6.3, the e.r.p. shall not exceed 30 watts for mobile equipment and outdoor fixed subscriber equipment. The e.r.p. shall not exceed 3 watts for portable equipment and indoor fixed subscriber equipment.

For base and fixed equipment other than fixed subscriber equipment, refer to SRSP-518 for the e.i.r.p. limits.

- RSS-132 Issue 4  
 5.4, the transmitter output power shall be measured in terms of average power. The equivalent radiated power (e.r.p.) shall not exceed 7 watts for mobile equipment and 3 watts for portable equipment. The effective isotropic radiated power (e.i.r.p.) shall not exceed the limits specified in SRSP-503 for base station equipment.
- RSS-133 Issue 6  
 6.4, the equivalent isotropically radiated power (e.i.r.p.) for transmitters shall not exceed the limits given in SRSP-510. Mobile stations and hand-held portables are limited to 2 watts maximum e.i.r.p. The equipment shall employ means to limit the power to the minimum necessary for successful communication.
- RSS-139 Issue 4  
 5.5, The maximum output power of the equipment shall comply with the limits specified below. In the tables, maximum power refers to the equivalent isotropically radiated power (e.i.r.p.) or total radiated power (TRP), measured in terms of average values.

**Table 3: Maximum power of equipment in the band 1 710-1 780 MHz**

Equipment type	Maximum power
Fixed station and base station	30 dB m e.i.r.p./ channel bandwidth
Subscriber equipment	30 dB m e.i.r.p./ channel bandwidth

- RSS-199 Issue 4

5.5, the maximum output power of the equipment shall comply with the limits specified in table 3. In this table, maximum power refers to the equivalent isotropically radiated power (e.i.r.p.) or total radiated power (TRP), measured in terms of average values.

Subscriber equipment other than fixed subscriber equipment shall not exceed an e.i.r.p of 2W per channel bandwidth.

Fixed subscriber equipment shall not exceed the following:

- I. conducted power of 2W per channel bandwidth for all ports
- II. e.i.r.p of 40 W per channel bandwidth

The maximum power limits for fixed station and base station are provided in Table 3. The limits in this RSS are specified for the purpose of certification and may not apply to all deployment scenarios. Consult SRSP-517 for more deployment details in the band 2 500-2 690 MHz.

**Table 3: Maximum power of fixed station and base station in the band 2 500-2 690 MHz**

Equipment type	Maximum power
Non-AAS fixed station and base station	e.i.r.p of 1 640 W / MHz
AAS fixed station and base station	TRP of 43 dB m / MHz

## 2.2.2. Limit of Radiated Spurious Emissions

### FCC

- §22.917(a), the power of any emission outside of the authorized operating frequency ranges must be attenuated below the transmitting power (P) by a factor of at least  $43 + 10\log(P)$  dB.
- §24.238(a), the power of any emission outside of the authorized operating frequency ranges must be attenuated below the transmitting power (P) by a factor of at least  $43 + 10 \log(P)$  dB.
- §27.53(c)(2), on any frequency outside the 776-788 MHz band, the power of any emission shall be attenuated outside the band below the transmitter power (P) by at least  $43 + 10 \log (P)$  dB.
- §27.53(f), For operations in the 746-758 MHz, 775-788 MHz, and 805-806 MHz bands, emissions in the band 1 559-1 610 MHz shall be limited to -70 dB W/MHz equivalent isotropically radiated power (EIRP) for wideband signals, and -80 dB W EIRP for discrete emissions of less than 700 Hz bandwidth. For the purpose of equipment authorization, a transmitter shall be tested with an antenna that is representative of the type that will be used with the equipment in normal operation.
- §27.53(g), the power of any emission outside a licensee's frequency band(s) of operation shall be attenuated below the transmitter power (P) within the licensed band(s) of operation, measured in watts, by at least  $43 + 10 \log (P)$  dB.
- §27.53(h)(1), for operations in the 1 695-1 710 MHz, 1 710-1 755 MHz, 1 755-1 780 MHz, 1 915-1 920 MHz, 1 995-2 000 MHz, 2 000-2 020 MHz, 2 110-2 155 MHz, 2 155-2 180 MHz, and 2 180-2 200 bands, the power of any emission outside a licensee's frequency block shall be attenuated below the transmitter power (P) in watts by at least  $43 + 10 \log_{10} (P)$  dB.
- §27.53(m)(4), for mobile digital stations, the attenuation factor shall be not less than  $40 + 10 \log_{10} (P)$  dB on all frequencies between the channel edge and 5 megahertz from the channel edge,  $43 + 10 \log_{10} (P)$  dB on all frequencies between 5 megahertz and X megahertz from the channel edge, and  $55 + 10 \log_{10} (P)$  dB on all frequencies more than X megahertz from the channel edge, where X is the greater of 6 megahertz or the actual emission bandwidth as defined in paragraph (m)(6) of this section. In addition, the attenuation factor shall not be less that  $43 + 10 \log_{10} (P)$  dB on all frequencies between 2 490.5 MHz and 2 496 MHz and  $55 + 10 \log_{10} (P)$  dB at or below 2 490.5 MHz. Mobile Satellite Service licensees operating on frequencies below 2 495 MHz may also submit a documented interference complaint against BRS licensees operating on channel BRS Channel 1 on the same terms and conditions as adjacent channel BRS or EBS licensees.

**IC**

- RSS-130 Issue 2

4.7.1, the unwanted emissions in any 100 kHz bandwidth on any frequency outside the low frequency edge and the high frequency edge of each frequency block range(s), shall be attenuated below the transmitter power, P (dB W), by at least  $43 + 10 \log_{10} p$  (watts), dB. However, in the 100 kHz band immediately outside of the equipment's frequency block range, a resolution bandwidth of 30 kHz may be employed.

4.7.2, In addition to the limit outlined in section 4.7.1 above, equipment operating in the frequency bands 746-756 MHz and 777-787 MHz shall also comply with the following restrictions:

a) The power of any unwanted emissions in any 6.25 kHz bandwidth for all frequencies between 763-775 MHz and 793-806 MHz shall be attenuated below the transmitter power, P (dB W), by at least:

(i)  $76 + 10 \log_{10} p$  (watts), dB, for base and fixed equipment, and

(ii)  $65 + 10 \log_{10} p$  (watts), dB, for mobile and portable equipment.

b) The e.i.r.p. in the band 1 559-1 610 MHz shall not exceed -70 dB W/MHz for wideband signal and -80 dB W for discrete emission with bandwidth less than 700 Hz.

- RSS-132 Issue 4

5.5, Equipment shall meet the unwanted emission limits specified below.

(i) In the first 1.0 MHz band immediately outside and adjacent to each of the sub-bands specified in Section 5.1, the power of emissions per any 1 % of the occupied bandwidth shall be attenuated below the transmitter output power P (dB W) by at least  $43 + 10 \log(p)$  dB.

(ii) After the first 1.0 MHz immediately outside and adjacent to each of the sub-bands, the power of emissions in any 100 kHz bandwidth shall be attenuated below the transmitter output power P (dB W) by at least  $43 + 10 \log(p)$  dB. If the measurement is performed using 1 % of the occupied bandwidth, power integration over 100 kHz is required.

- RSS-133 Issue 6

6.5, Equipment shall comply with the limits in (i) and (ii) below.

(i) In the 1.0 MHz bands immediately outside and adjacent to the equipment's operating frequency block, the emission power per any 1 % of the emission bandwidth shall be attenuated (in dB) below the transmitter output power P (dB W) by at least  $43 + 10 \log_{10} p$ (watts).

(ii) After the first 1.0 MHz, the emission power in any 1 MHz bandwidth shall be attenuated (in dB) below the transmitter output power P (dB W) by at least  $43 + 10 \log_{10} p$ (watts). If the measurement is performed using 1 % of the emission bandwidth, power integration over 1.0 MHz is required.

- RSS-139 Issue 4

5.6, Unwanted emissions shall be measured in terms of average values.

For all equipment, the TRP or total conducted power (sum of conducted power across all antenna connectors) of the unwanted emissions outside the frequency block or frequency block group shall not exceed the limits shown in table 6.

**Table 6: Unwanted emission limits**

Offset from the edge of the frequency block or frequency block group	Unwanted emission limit
$\leq 1$ MHz	-13 dB m/(1% of OB)*
$> 1$ MHz	-13 dB m

\* OB is the occupied bandwidth



- RSS-199 Issue 4

5.6, unwanted emissions shall be measured in terms of average values when the transmitter is operating at the manufacturer's rated power and modulated as specified in RSS-Gen.

Equipment shall meet the unwanted emission limits, specified below, outside each frequency block group. For each channel bandwidth supported by the equipment under test, the unwanted emissions shall be measured and reported for two channel frequencies: one located as close as possible to the low end and one located as close as possible to the high end of the equipment's operating frequency range.

For the unwanted emission limits, in the 1 MHz band immediately outside and adjacent to the frequency block group, the power shall be measured with a resolution bandwidth of at least 1% of the occupied bandwidth for fixed stations, base stations, and fixed subscriber equipment, and 2 % for subscriber equipment other than fixed subscriber equipment. Beyond this 1 MHz band, a resolution bandwidth of 1 MHz shall be used. A narrower resolution bandwidth can be used, provided that the measured power is integrated over the full required measurement bandwidth of 1 MHz, or 1 % or 2 % of the occupied bandwidth, as applicable.

For all equipment, the TRP or total conducted power (sum of conducted power across all antenna connectors), where applicable, of the unwanted emissions outside the frequency block or frequency block group shall not exceed the limits shown in the tables below.

**Table 4: Unwanted emission limits for fixed station, base station and fixed subscriber equipment**

Offset from the edge of the frequency block or frequency block group (MHz)	Unwanted emission limit
≤1	-13 dB m/(1% of OB*)
>1	-13 dB m/MHz

\* OB is the occupied bandwidth

**Table 5: Unwanted emission limits for subscriber equipment other than fixed subscriber equipment**

Offset from the edge of the frequency block or frequency block group (MHz)	Unwanted emission limit
0-1	-10 dB m/(2% of OB*)
1-5	-10 dB m/MHz
5-X**	-13 dB m/MHz
≥X	-25 dB m/MHz

\* OB is the occupied bandwidth

\*\* X is 6 MHz or the equipment occupied bandwidth, whichever is greater

In addition to complying with the limits in table 5, subscriber equipment other than fixed subscriber equipment shall not exceed -13 dB m/MHz on all frequencies between 2 490.5 MHz and 2 496 MHz, and -25 dB m/MHz at or below 2 490.5 MHz.

## 2.3. Test Procedure

### 2.3.1. E.R.P. or E.I.R.P. from conducted RF output power

According to subclause 5.2.5.5 of ANSI C63.26-2015 E.R.P. and E.I.R.P. are defined as the product of the power supplied to the antenna and its gain.

The relevant equation for determining the E.R.P. or E.I.R.P. from the conducted RF output power measured using the guidance provided above is:

$$\text{E.R.P. or E.I.R.P.} = P_{\text{Meas}} + G_T$$

where:

E.R.P. or E.I.R.P. = effective radiated power or equivalent isotropically radiated power, respectively  
 (expressed in the same units as  $P_{\text{Meas}}$ , typically dBW or dBm);

$P_{\text{Meas}}$  = measured transmitter output power or PSD, in dBm or dBW;

$G_T$  = gain of the transmitting antenna, in dBd (ERP) or dBi (EIRP);

### 2.3.2. Radiated Spurious Emissions

The test based on ANSI/TIA 603E: 2016 and ANSI C63.26-2015 and KDB 971168 D01 Power Meas License Digital Systems v03r01.

1. On a test site, the EUT shall be placed at 0.8 m or 1.5 m height on a turn table, and in the position close to normal use as declared by the applicant.
2. The test antenna shall be oriented initially for vertical polarization located 3 m from EUT to correspond to the fundamental frequency of the transmitter.
3. The output of the test antenna shall be connected to the measuring receiver and the peak detector is used for the measurement.
4. Radiated spurious emissions measurement method was set as follows:  
 RBW = 100 kHz for emissions below 1 GHz and 1 MHz for emissions above 1 GHz, VBW ≥ 3 x RBW,  
 Detector = RMS, trace mode = max hold, per the guidelines of KDB 971168 D01 Power Meas License Digital Systems v03r01.
5. The transmitter shall be switched on, the measuring receiver shall be tuned to the frequency of the transmitter under test.
6. The test antenna shall be raised and lowered through the specified range of height until the maximum signal level is detected by the measuring receiver.
7. The transmitter shall be rotated through 360° in the horizontal plane, until the maximum signal level is detected by the measuring receiver.
8. The test antenna shall be raised and lowered again through the specified range of height until the maximum signal level is detected by the measuring receiver.
9. The maximum signal level detected by the measuring receiver shall be noted.
10. In necessary, the input attenuator setting on the measuring receiver shall be adjusted in order to increase the sensitivity of the measuring receiver.
11. The test antenna shall be raised and lowered through the specified range of height to ensure that the maximum signal is received.
12. The measurement shall be repeated with the test antenna orientated for horizontal polarization.

## 2.4. Test results

Ambient temperature : (23 ± 1) °C  
 Relative humidity : 47 ± 2 %

### 2.4.1. E.R.P. / E.I.R.P.

Band	Frequency (MHz)	Maximum Conducted Power (dB m)	Maximum Conducted Power (W)	Antenna Gain (dB i)	Maximum E.I.R.P. (dB m)	Maximum E.I.R.P. (W)	Maximum E.R.P. (dB m)	Maximum E.R.P. (W)	Limit
2	1 850 ~ 1 910	22.66	0.185	5.97	28.63	0.729			2 W E.I.R.P.
66/4	1 710 ~ 1 780	22.66	0.185	4.13	26.79	0.478			1 W E.I.R.P.
5	824 ~ 849	22.90	0.195	2.18	25.08	0.322	22.93	0.196	7 W E.R.P.
7	2 500 ~ 2 570	22.70	0.186	3.97	26.67	0.465			2 W E.I.R.P.
12/17	699 ~ 716	22.21	0.166	-1.74	20.47	0.111	18.32	0.068	30 W E.R.P.
13	777 ~ 787	22.05	0.160	-0.24	21.81	0.152	19.66	0.092	30 W E.R.P.

#### Remark;

1. E.I.R.P. (dB m) = Maximum Conducted Power (dB m) + Antenna Gain (dB i)
2. E.R.P. (dB m) = E.I.R.P. (dB m) - 2.15 (dB); where E.R.P. and E.I.R.P. are expressed in consistent units.

### 2.4.2. Radiated spurious emissions

#### LTE band 2 (15 MHz - QPSK)

Frequency (MHz)	Measured Level (dB $\mu$ V)	Ant. Pol.	AF (dB/m)	AMP+CL (dB)	E (dB $\mu$ V/m)	CF (dB)	E.I.R.P. (dB m)	Limit (dB m)	Margin (dB)
Low Channel (1 857.5 MHz)									
5 571.92	41.36	H	34.10	-27.40	48.06	-95.26	-47.20	-13	34.20
5 571.85	48.06	V	34.10	-27.41	54.75	-95.26	-40.51	-13	27.51
Above 5 600.00	Not detected	-	-	-	-	-	-	-	-
Middle Channel (1 880.0 MHz)									
5 639.25	44.88	V	34.10	-27.56	51.42	-95.26	-43.84	-13	30.84
5 639.42	48.35	H	34.10	-27.60	54.85	-95.26	<b>-40.41</b>	-13	27.41
Above 5 700.00	Not detected	-	-	-	-	-	-	-	-
High Channel (1 902.5 MHz)									
5 707.04	39.35	V	34.11	-28.38	45.08	-95.26	-50.18	-13	37.18
5 706.88	46.35	H	34.11	-28.37	52.09	-95.26	-43.17	-13	30.17
Above 5 800.00	Not detected	-	-	-	-	-	-	-	-

#### LTE band 66/4 (10 MHz - QPSK)

Frequency (MHz)	Measured Level (dB $\mu$ V)	Ant. Pol.	AF (dB/m)	AMP+CL (dB)	E (dB $\mu$ V/m)	CF (dB)	E.I.R.P. (dB m)	Limit (dB m)	Margin (dB)
Low Channel (1 715.0 MHz)									
Below 1 000.00	Not detected	-	-	-	-	-	-	-	-
Above 1 000.00	Not detected	-	-	-	-	-	-	-	-
Middle Channel (1 745.0 MHz)									
Below 1 000.00	Not detected	-	-	-	-	-	-	-	-
Above 1 000.00	Not detected	-	-	-	-	-	-	-	-
High Channel (1 775.0 MHz)									
Below 1 000.00	Not detected	-	-	-	-	-	-	-	-
Above 1 000.00	Not detected	-	-	-	-	-	-	-	-

**LTE band 5 (3 MHz - QPSK)**

Frequency (MHz)	Measured Level (dB $\mu$ V)	Ant. Pol.	AF (dB/m)	AMP+CL (dB)	E (dB $\mu$ V/m)	CF (dB)	E.R.P. (dB m)	Limit (dB m)	Margin (dB)
Low Channel (825.5 MHz)									
1 650.95	55.06	H	25.82	-36.60	44.28	-97.41	-53.13	-13	40.13
1 650.98	69.10	V	25.82	-36.60	58.32	-97.41	<b>-39.09</b>	-13	26.09
2 476.46	56.28	H	28.31	-33.06	51.53	-97.41	-45.88	-13	32.88
2 476.45	56.47	V	28.31	-33.06	51.72	-97.41	-45.69	-13	32.69
Above 2 500.00	Not detected	-	-	-	-	-	-	-	-
Middle Channel (836.5 MHz)									
1 673.03	54.40	H	26.21	-36.21	44.40	-97.41	-53.01	-13	40.01
1 673.00	64.04	V	26.21	-36.21	54.04	-97.41	-43.37	-13	30.37
2 509.45	53.53	H	28.44	-34.37	47.60	-97.41	-49.81	-13	36.81
2 509.50	52.20	V	28.44	-34.37	46.27	-97.41	-51.14	-13	38.14
Above 2 600.00	Not detected	-	-	-	-	-	-	-	-
High Channel (847.5 MHz)									
1 695.03	52.63	H	26.61	-36.25	42.99	-97.41	-54.42	-13	41.42
1 695.02	60.08	V	26.61	-36.25	50.44	-97.41	-46.97	-13	33.97
2 542.33	54.67	H	28.57	-33.89	49.35	-97.41	-48.06	-13	35.06
2 542.62	52.65	H	28.57	-33.89	47.33	-97.41	-50.08	-13	37.08
Above 2 600.00	Not detected	-	-	-	-	-	-	-	-

**LTE band 7 (20 MHz - QPSK)**

Frequency (MHz)	Measured Level (dB $\mu$ V)	Ant. Pol.	AF (dB/m)	AMP+CL (dB)	E (dB $\mu$ V/m)	CF (dB)	E.I.R.P. (dB m)	Limit (dB m)	Margin (dB)
Low Channel (2 510.0 MHz)									
5 002.35	28.74	H	33.40	-29.17	32.97	-95.26	-62.29	-25	37.29
5 002.34	37.78	V	33.40	-29.17	42.01	-95.26	-53.25	-25	28.25
7 503.33	35.62	H	36.09	-27.36	44.35	-95.26	-50.91	-25	25.91
7 503.43	38.10	V	36.09	-27.36	46.83	-95.26	-48.43	-25	23.43
12 505.42	30.10	H	38.50	-23.74	44.86	-95.26	-50.40	-25	25.40
12 505.43	33.62	V	38.50	-23.74	48.38	-95.26	-46.88	-25	21.88
Above 12 600.00	Not detected	-	-	-	-	-	-	-	-
Middle Channel (2 535.0 MHz)									
5 052.24	32.42	H	33.40	-28.57	37.25	-95.26	-58.01	-25	33.01
5 052.17	37.27	V	33.40	-28.57	42.10	-95.26	-53.16	-25	28.16
7 578.30	35.37	H	36.00	-27.44	43.93	-95.26	-51.33	-25	26.33
7 578.22	34.76	V	36.00	-27.44	43.32	-95.26	-51.94	-25	26.94
12 630.46	31.70	H	38.66	-23.69	46.67	-95.26	-48.59	-25	23.59
12 630.44	36.52	V	38.66	-23.69	51.49	-95.26	-43.77	-25	18.77
Above 12 700.00	Not detected	-	-	-	-	-	-	-	-
High Channel (2 560.0 MHz)									
5 102.07	28.85	H	33.50	-30.08	32.27	-95.26	-62.99	-25	37.99
5 102.14	38.16	V	33.50	-30.08	41.58	-95.26	-53.68	-25	28.68
7 653.27	37.41	H	35.99	-27.23	46.17	-95.26	-49.09	-25	24.09
7 653.35	39.58	H	35.99	-27.23	48.34	-95.26	-46.92	-25	21.92
12 755.35	30.07	V	38.91	-23.26	45.72	-95.26	-49.54	-25	24.54
12 755.62	35.95	H	38.91	-23.25	51.61	-95.26	<b>-43.65</b>	-25	18.65
Above 12 800.00	Not detected	-	-	-	-	-	-	-	-

**LTE band 12/17 (1.4 MHz - QPSK)**

Frequency (MHz)	Measured Level (dB $\mu$ V)	Ant. Pol.	AF (dB/m)	AMP+CL (dB)	E (dB $\mu$ V/m)	CF (dB)	E.R.P. (dB m)	Limit (dB m)	Margin (dB)
Low Channel (699.7 MHz)									
1 399.27	58.56	H	25.10	-37.45	46.21	-97.41	-51.20	-13	38.20
1 399.31	62.99	V	25.10	-37.45	50.64	-97.41	-46.77	-13	33.77
2 098.71	72.03	H	27.90	-33.68	66.25	-97.41	<b>-31.16</b>	-13	18.16
2 098.71	71.29	V	27.90	-33.68	65.51	-97.41	-31.90	-13	18.90
3 498.00	50.47	H	31.10	-32.49	49.08	-97.41	-48.33	-13	35.33
3 497.89	57.00	V	31.10	-32.49	55.61	-97.41	-41.80	-13	28.80
Above 3 500.00	Not detected	-	-	-	-	-	-	-	-
Middle Channel (707.5 MHz)									
1 414.70	58.62	H	25.13	-37.39	46.36	-97.41	-51.05	-13	38.05
1 414.83	61.64	V	25.13	-37.39	49.38	-97.41	-48.03	-13	35.03
2 122.29	68.11	H	27.77	-34.07	61.81	-97.41	-35.60	-13	22.60
2 121.96	67.43	V	27.77	-34.06	61.14	-97.41	-36.27	-13	23.27
3 537.10	49.79	H	31.17	-32.53	48.43	-97.41	-48.98	-13	35.98
3 536.96	54.77	V	31.17	-32.53	53.41	-97.41	-44.00	-13	31.00
Above 3 600.00	Not detected	-	-	-	-	-	-	-	-
High Channel (715.3 MHz)									
1 430.42	56.97	H	25.16	-37.30	44.83	-97.41	-52.58	-13	39.58
1 430.43	62.98	V	25.16	-37.30	50.84	-97.41	-46.57	-13	33.57
2 145.54	64.52	H	27.63	-34.78	57.37	-97.41	-40.04	-13	27.04
2 145.74	62.27	H	27.63	-34.78	55.12	-97.41	-42.29	-13	29.29
3 576.10	45.76	V	31.30	-31.58	45.48	-97.41	-51.93	-13	38.93
3 575.88	48.96	H	31.30	-31.58	48.68	-97.41	-48.73	-13	35.73
Above 3 600.00	Not detected	-	-	-	-	-	-	-	-

**LTE band 13 (5 MHz - QPSK)**

Frequency (MHz)	Measured Level (dB $\mu$ V)	Ant. Pol.	AF (dB/m)	AMP+CL (dB)	E (dB $\mu$ V/m)	CF (dB)	E.R.P./E.I.R.P. (dB m)	Limit (dB m)	Margin (dB)
Low Channel (779.5 MHz)									
1 554.78	50.81	H	25.22	-36.06	39.97	-97.41	-57.44	-13	44.44
1 554.56	48.51	V	25.22	-36.06	37.67	-97.41	-59.74	-13	46.74
2 332.06	68.52	H	28.09	-34.05	62.56	-97.41	-34.85	-13	21.85
2 332.06	62.31	V	28.09	-34.05	56.35	-97.41	-41.06	-13	28.06
3 886.75	43.74	H	32.30	-30.15	45.89	-97.41	-51.52	-13	38.52
3 886.75	41.88	V	32.30	-30.15	44.03	-97.41	-53.38	-13	40.38
Above 3 900.00	Not detected	-	-	-	-	-	-	-	-
Middle Channel (782.0 MHz)									
1 559.74	51.47	H	25.24	-36.15	40.56	-95.26	<b>-54.70</b>	-40	14.70
1 559.67	49.22	V	25.24	-36.15	38.31	-95.26	-56.95	-40	16.95
2 339.47	67.87	H	28.14	-34.21	61.80	-97.41	-35.61	-13	22.61
2 339.54	64.09	V	28.14	-34.21	58.02	-97.41	-39.39	-13	26.39
3 899.23	41.12	H	32.30	-29.88	43.54	-97.41	-53.87	-13	40.87
3 899.32	41.93	V	32.30	-29.87	44.36	-97.41	-53.05	-13	40.05
Above 3 900.00	Not detected	-	-	-	-	-	-	-	-
High Channel (784.5 MHz)									
1 564.77	49.87	H	25.26	-36.23	38.90	-95.26	-56.36	-40	16.36
1 564.51	48.86	V	25.26	-36.23	37.89	-95.26	-57.37	-40	17.37
2 347.09	66.38	H	28.18	-34.36	60.20	-97.41	-37.21	-13	24.21
2 347.02	63.69	V	28.18	-34.36	57.51	-97.41	-39.90	-13	26.90
3 911.55	38.12	H	32.30	-29.97	40.45	-97.41	-56.96	-13	43.96
3 911.74	40.51	V	32.30	-29.97	42.84	-97.41	-54.57	-13	41.57
Above 4 000.00	Not detected	-	-	-	-	-	-	-	-

**Remark;**

1. AF = Antenna Factor, CL = Cable Loss, CF = Conversion Factor.
2. E (dB $\mu$ V/m) = Measured Level (dB $\mu$ V) + Antenna Factor (dB/m) + AMP (dB) + Cable Loss (dB).
3. E.I.R.P. (dB m) = E (dB $\mu$ V/m) + CF (dB).
4. E.R.P. (dB m) = E (dB $\mu$ V/m) + CF (dB) - 2.15 (dB); where E.R.P. and E.I.R.P. are expressed in consistent units.
5. CF (dB) = 20 log D - 104.8; where D is the measurement distance in meters, According to KDB 971168 D01 v03r01 5.8.4.
6. The frequency spectrum is examined from 9 kHz to the 10<sup>th</sup> harmonic of the fundamental frequency of the transmitter. No other spurious and harmonic emissions were reported greater than listed emissions above table.



### 3. Conducted Output Power

#### 3.1. Limit

CFR 47, Section FCC §2.1046 and IC RSS-Gen Issue 5 6.12.

#### 3.2. Test Procedure

Output power shall be measured at the RF output terminals for all configurations.

1. The RF output of the transmitter was connected to the input of the mobile test unit in order to establish communication with the EUT.
2. The EUT was set up for the max. output power with pseudo random data modulation by using mobile test unit parameters.
3. The measurement performed using a wideband RF power meter.
4. This EUT was tested under all configurations and the highest power was investigated and reported.

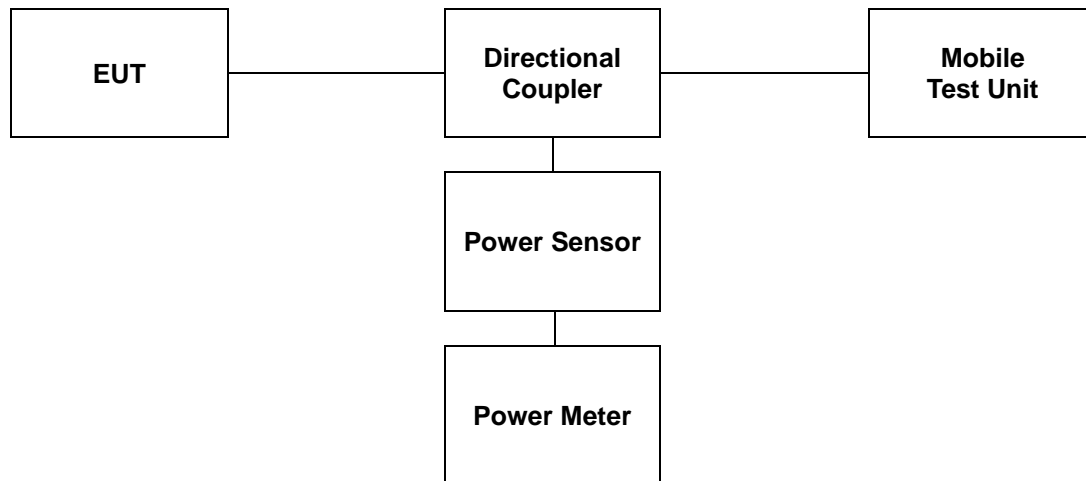

### 3.3. Test Result

Ambient temperature : (23 ± 1) °C  
 Relative humidity : 47 ± 2 %

LTE Band 2									
Bandwidth (MHz)	Modulation	RB Size	RB Offset	Conducted Output Power					
				18607 (1 850.7 MHz)		18900 (1 880.0 MHz)		19193 (1 909.3 MHz)	
				(dB m)	(W)	(dB m)	(W)	(dB m)	(W)
1.4	QPSK	1	0	22.38	0.173	<b>22.54</b>	<b>0.179</b>	22.08	0.161
		1	3	22.44	0.175	22.52	0.179	22.03	0.160
		1	5	22.36	0.172	22.50	0.178	22.01	0.159
		3	0	22.37	0.173	22.41	0.174	22.00	0.158
		3	2	22.41	0.174	22.50	0.178	22.01	0.159
		3	3	22.35	0.172	22.51	0.178	21.99	0.158
		6	0	21.41	0.138	21.62	0.145	21.26	0.134
	16QAM	1	0	21.49	0.141	21.71	0.148	21.33	0.136
		1	3	21.61	0.145	21.66	0.147	21.32	0.136
		1	5	21.60	0.145	21.66	0.147	21.27	0.134
		3	0	21.34	0.136	21.78	0.151	21.31	0.135
		3	2	21.42	0.139	21.84	0.153	21.37	0.137
		3	3	21.39	0.138	<b>21.90</b>	<b>0.155</b>	21.31	0.135
		6	0	20.53	0.113	20.77	0.119	20.36	0.109
LTE Band 2									
Bandwidth (MHz)	Modulation	RB Size	RB Offset	Conducted Output Power					
				18615 (1 851.5 MHz)		18900 (1 880.0 MHz)		19185 (1 908.5 MHz)	
				(dB m)	(W)	(dB m)	(W)	(dB m)	(W)
3	QPSK	1	0	22.40	0.174	22.45	0.176	22.12	0.163
		1	7	22.50	0.178	<b>22.53</b>	<b>0.179</b>	22.30	0.170
		1	14	22.49	0.177	22.52	0.179	22.29	0.169
		8	0	21.61	0.145	21.63	0.146	21.28	0.134
		8	4	21.59	0.144	21.69	0.148	21.27	0.134
		8	7	21.62	0.145	21.66	0.147	21.24	0.133
		15	0	21.53	0.142	21.65	0.146	21.30	0.135
	16QAM	1	0	21.68	0.147	21.67	0.147	21.38	0.137
		1	7	21.79	0.151	21.81	0.152	21.58	0.144
		1	14	21.67	0.147	<b>21.87</b>	<b>0.154</b>	21.47	0.140
		8	0	20.59	0.115	20.64	0.116	20.33	0.108
		8	4	20.72	0.118	20.76	0.119	20.37	0.109
		8	7	20.65	0.116	20.80	0.120	20.29	0.107
		15	0	20.57	0.114	20.63	0.116	20.29	0.107
LTE Band 2									
Bandwidth (MHz)	Modulation	RB Size	RB Offset	Conducted Output Power					
				18625 (1 852.5 MHz)		18900 (1 880.0 MHz)		19175 (1 907.5 MHz)	
				(dB m)	(W)	(dB m)	(W)	(dB m)	(W)
5	QPSK	1	0	22.36	0.172	22.40	0.174	22.21	0.166
		1	12	22.41	0.174	22.60	0.182	22.20	0.166
		1	24	22.41	0.174	<b>22.62</b>	<b>0.183</b>	22.17	0.165
		12	0	21.59	0.144	21.71	0.148	21.33	0.136
		12	6	21.61	0.145	21.83	0.152	21.33	0.136
		12	13	21.59	0.144	21.79	0.151	21.33	0.136
		25	0	21.61	0.145	21.62	0.145	21.30	0.135
	16QAM	1	0	21.65	0.146	21.64	0.146	21.46	0.140
		1	12	21.66	0.147	<b>21.91</b>	<b>0.155</b>	21.57	0.144
		1	24	21.63	0.146	21.89	0.155	21.45	0.140
		12	0	20.56	0.114	20.71	0.118	20.30	0.107
		12	6	20.62	0.115	20.84	0.121	20.32	0.108
		12	13	20.66	0.116	20.72	0.118	20.36	0.109
		25	0	20.58	0.114	20.62	0.115	20.31	0.107

LTE Band 2									
Bandwidth (MHz)	Modulation	RB Size	RB Offset	Conducted Output Power					
				18650 (1 855.0 MHz)		18900 (1 880.0 MHz)		19150 (1 905.0 MHz)	
				(dB m)	(W)	(dB m)	(W)	(dB m)	(W)
10	QPSK	1	0	22.35	0.172	22.46	0.176	22.16	0.164
		1	25	22.17	0.165	22.47	0.177	22.26	0.168
		1	49	22.39	0.173	<b>22.59</b>	<b>0.182</b>	22.03	0.160
		25	0	21.56	0.143	21.74	0.149	21.43	0.139
		25	12	21.57	0.144	21.76	0.150	21.42	0.139
		25	25	21.49	0.141	21.75	0.150	21.31	0.135
		50	0	21.54	0.143	21.74	0.149	21.39	0.138
	16QAM	1	0	21.57	0.144	21.66	0.147	21.63	0.146
		1	25	21.40	0.138	21.76	0.150	21.54	0.143
		1	49	21.62	0.145	<b>21.87</b>	<b>0.154</b>	21.50	0.141
		25	0	20.55	0.114	20.75	0.119	20.45	0.111
		25	12	20.59	0.115	20.81	0.121	20.48	0.112
		25	25	20.52	0.113	20.69	0.117	20.35	0.108
		50	0	20.53	0.113	20.69	0.117	20.39	0.109
LTE Band 2									
Bandwidth (MHz)	Modulation	RB Size	RB Offset	Conducted Output Power					
				18675 (1 857.5 MHz)		18900 (1 880.0 MHz)		19125 (1 902.5 MHz)	
				(dB m)	(W)	(dB m)	(W)	(dB m)	(W)
15	QPSK	1	0	22.46	0.176	22.60	0.182	22.37	0.173
		1	36	22.44	0.175	<b>22.66</b>	<b>0.185</b>	22.31	0.170
		1	74	22.46	0.176	22.62	0.183	22.45	0.176
		36	0	21.61	0.145	21.79	0.151	21.50	0.141
		36	18	21.65	0.146	21.85	0.153	21.57	0.144
		36	37	21.62	0.145	21.88	0.154	21.55	0.143
		75	0	21.63	0.146	21.87	0.154	21.48	0.141
	16QAM	1	0	21.73	0.149	21.93	0.156	21.60	0.145
		1	36	21.72	0.149	21.88	0.154	21.54	0.143
		1	74	21.77	0.150	<b>21.97</b>	<b>0.157</b>	21.64	0.146
		36	0	20.58	0.114	20.79	0.120	20.51	0.112
		36	18	20.64	0.116	20.81	0.121	20.57	0.114
		36	37	20.63	0.116	20.88	0.122	20.60	0.115
		75	0	20.65	0.116	20.85	0.122	20.56	0.114
LTE Band 2									
Bandwidth (MHz)	Modulation	RB Size	RB Offset	Conducted Output Power					
				18700 (1 860.0 MHz)		18900 (1 880.0 MHz)		19100 (1 900.0 MHz)	
				(dB m)	(W)	(dB m)	(W)	(dB m)	(W)
20	QPSK	1	0	22.42	0.175	<b>22.61</b>	<b>0.182</b>	22.39	0.173
		1	50	22.46	0.176	22.59	0.182	22.38	0.173
		1	99	22.31	0.170	22.58	0.181	22.34	0.171
		50	0	21.58	0.144	21.83	0.152	21.56	0.143
		50	25	21.61	0.145	21.84	0.153	21.59	0.144
		50	50	21.60	0.145	21.89	0.155	21.58	0.144
		100	0	21.59	0.144	21.85	0.153	21.53	0.142
	16QAM	1	0	21.71	0.148	21.79	0.151	21.62	0.145
		1	50	21.77	0.150	<b>21.82</b>	<b>0.152</b>	21.64	0.146
		1	99	21.62	0.145	21.81	0.152	21.74	0.149
		50	0	20.61	0.115	20.84	0.121	20.63	0.116
		50	25	20.65	0.116	20.89	0.123	20.61	0.115
		50	50	20.64	0.116	20.91	0.123	20.60	0.115
		100	0	20.56	0.114	20.81	0.121	20.53	0.113

LTE Band 66/4									
Bandwidth (MHz)	Modulation	RB Size	RB Offset	Conducted Output Power					
				131979 (1 710.7 MHz)		132322 (1 745.0 MHz)		132665 (1 779.3 MHz)	
				(dB m)	(W)	(dB m)	(W)	(dB m)	(W)
1.4	QPSK	1	0	22.32	0.171	22.15	0.164	<b>22.39</b>	<b>0.173</b>
		1	3	22.38	0.173	22.10	0.162	22.26	0.168
		1	5	22.29	0.169	22.09	0.162	22.26	0.168
		3	0	22.26	0.168	22.12	0.163	22.36	0.172
		3	2	22.37	0.173	22.15	0.164	22.27	0.169
		3	3	22.33	0.171	22.12	0.163	22.23	0.167
		6	0	21.35	0.136	21.29	0.135	21.49	0.141
	16QAM	1	0	21.45	0.140	21.30	0.135	<b>21.70</b>	<b>0.148</b>
		1	3	21.70	0.148	21.42	0.139	21.53	0.142
		1	5	21.57	0.144	21.42	0.139	21.53	0.142
		3	0	21.48	0.141	21.44	0.139	21.62	0.145
		3	2	21.34	0.136	21.53	0.142	21.60	0.145
		3	3	21.28	0.134	21.47	0.140	21.53	0.142
		6	0	20.48	0.112	20.38	0.109	20.57	0.114
LTE Band 66/4									
Bandwidth (MHz)	Modulation	RB Size	RB Offset	Conducted Output Power					
				131987 (1 711.5 MHz)		132322 (1 745.0 MHz)		132657 (1 778.5 MHz)	
				(dB m)	(W)	(dB m)	(W)	(dB m)	(W)
3	QPSK	1	0	22.35	0.172	22.15	0.164	22.28	0.169
		1	7	22.45	0.176	22.16	0.164	22.45	0.176
		1	14	22.40	0.174	22.18	0.165	<b>22.47</b>	<b>0.177</b>
		8	0	21.49	0.141	21.31	0.135	21.40	0.138
		8	4	21.54	0.143	21.30	0.135	21.40	0.138
		8	7	21.50	0.141	21.27	0.134	21.43	0.139
		15	0	21.53	0.142	21.28	0.134	21.39	0.138
	16QAM	1	0	21.63	0.146	21.52	0.142	21.47	0.140
		1	7	<b>21.76</b>	<b>0.150</b>	21.46	0.140	21.67	0.147
		1	14	21.76	0.150	21.43	0.139	21.70	0.148
		8	0	20.63	0.116	20.33	0.108	20.44	0.111
		8	4	20.59	0.115	20.38	0.109	20.44	0.111
		8	7	20.61	0.115	20.35	0.108	20.46	0.111
		15	0	20.57	0.114	20.28	0.107	20.47	0.111
LTE Band 66/4									
Bandwidth (MHz)	Modulation	RB Size	RB Offset	Conducted Output Power					
				131997 (1 712.5 MHz)		132322 (1 745.0 MHz)		132647 (1 777.5 MHz)	
				(dB m)	(W)	(dB m)	(W)	(dB m)	(W)
5	QPSK	1	0	22.32	0.171	22.15	0.164	22.22	0.167
		1	12	22.37	0.173	22.25	0.168	22.32	0.171
		1	24	<b>22.38</b>	<b>0.173</b>	22.23	0.167	22.36	0.172
		12	0	21.51	0.142	21.34	0.136	21.40	0.138
		12	6	21.58	0.144	21.37	0.137	21.42	0.139
		12	13	21.59	0.144	21.44	0.139	21.47	0.140
		25	0	21.55	0.143	21.34	0.136	21.37	0.137
	16QAM	1	0	21.58	0.144	21.42	0.139	21.52	0.142
		1	12	21.74	0.149	21.56	0.143	21.59	0.144
		1	24	21.71	0.148	21.59	0.144	<b>21.79</b>	<b>0.151</b>
		12	0	20.55	0.114	20.38	0.109	20.38	0.109
		12	6	20.59	0.115	20.41	0.110	20.46	0.111
		12	13	20.58	0.114	20.40	0.110	20.51	0.112
		25	0	20.54	0.113	20.33	0.108	20.39	0.109

LTE Band 66/4									
Bandwidth (MHz)	Modulation	RB Size	RB Offset	Conducted Output Power					
				132022 (1 715.0 MHz)		132322 (1 745.0 MHz)		132622 (1 775.0 MHz)	
				(dB m)	(W)	(dB m)	(W)	(dB m)	(W)
10	QPSK	1	0	22.34	0.171	<b>22.66</b>	<b>0.185</b>	22.30	0.170
		1	25	22.22	0.167	22.13	0.163	22.24	0.167
		1	49	22.40	0.174	22.25	0.168	22.17	0.165
		25	0	21.50	0.141	21.35	0.136	21.37	0.137
		25	12	21.51	0.142	21.36	0.137	21.38	0.137
		25	25	21.46	0.140	21.31	0.135	21.33	0.136
		50	0	21.46	0.140	21.32	0.136	21.41	0.138
	16QAM	1	0	21.57	0.144	21.33	0.136	21.59	0.144
		1	25	21.60	0.145	21.38	0.137	21.56	0.143
		1	49	<b>21.74</b>	<b>0.149</b>	21.45	0.140	21.40	0.138
		25	0	20.54	0.113	20.39	0.109	20.34	0.108
		25	12	20.55	0.114	20.37	0.109	20.36	0.109
		25	25	20.51	0.112	20.36	0.109	20.35	0.108
		50	0	20.48	0.112	20.30	0.107	20.45	0.111
LTE Band 66/4									
Bandwidth (MHz)	Modulation	RB Size	RB Offset	Conducted Output Power					
				132047 (1 717.5 MHz)		132322 (1 745.0 MHz)		132597 (1 772.5 MHz)	
				(dB m)	(W)	(dB m)	(W)	(dB m)	(W)
15	QPSK	1	0	22.51	0.178	22.34	0.171	22.51	0.178
		1	36	22.53	0.179	22.42	0.175	22.48	0.177
		1	74	22.56	0.180	22.35	0.172	<b>22.63</b>	<b>0.183</b>
		36	0	21.66	0.147	21.52	0.142	21.67	0.147
		36	18	21.65	0.146	21.54	0.143	21.64	0.146
		36	37	21.60	0.145	21.50	0.141	21.61	0.145
		75	0	21.66	0.147	21.54	0.143	21.65	0.146
	16QAM	1	0	21.73	0.149	21.68	0.147	21.71	0.148
		1	36	21.82	0.152	21.61	0.145	21.88	0.154
		1	74	21.83	0.152	21.79	0.151	<b>21.94</b>	<b>0.156</b>
		36	0	20.67	0.117	20.54	0.113	20.70	0.117
		36	18	20.64	0.116	20.51	0.112	20.62	0.115
		36	37	20.62	0.115	20.48	0.112	20.65	0.116
		75	0	20.66	0.116	20.50	0.112	20.61	0.115
LTE Band 66/4									
Bandwidth (MHz)	Modulation	RB Size	RB Offset	Conducted Output Power					
				132072 (1 720.0 MHz)		132322 (1 745.0 MHz)		132572 (1 770.0 MHz)	
				(dB m)	(W)	(dB m)	(W)	(dB m)	(W)
20	QPSK	1	0	22.47	0.177	22.32	0.171	22.44	0.175
		1	50	22.46	0.176	22.33	0.171	<b>22.56</b>	<b>0.180</b>
		1	99	22.38	0.173	22.38	0.173	22.49	0.177
		50	0	21.63	0.146	21.54	0.143	21.68	0.147
		50	25	21.65	0.146	21.51	0.142	21.70	0.148
		50	50	21.62	0.145	21.49	0.141	21.61	0.145
		100	0	21.61	0.145	21.56	0.143	21.48	0.141
	16QAM	1	0	21.61	0.145	21.49	0.141	21.65	0.146
		1	50	21.83	0.152	21.70	0.148	21.90	0.155
		1	99	21.69	0.148	21.66	0.147	<b>21.94</b>	<b>0.156</b>
		50	0	20.67	0.117	20.57	0.114	20.72	0.118
		50	25	20.65	0.116	20.53	0.113	20.69	0.117
		50	50	20.62	0.115	20.51	0.112	20.62	0.115
		100	0	20.66	0.116	20.49	0.112	20.51	0.112

LTE Band 5									
Bandwidth (MHz)	Modulation	RB Size	RB Offset	Conducted Output Power					
				20407 (824.7 MHz)		20525 (836.5 MHz)		20643 (848.3 MHz)	
				(dB m)	(W)	(dB m)	(W)	(dB m)	(W)
1.4	QPSK	1	0	21.78	0.151	22.34	0.171	22.59	0.182
		1	3	21.91	0.155	22.33	0.171	<b>22.62</b>	<b>0.183</b>
		1	5	21.92	0.156	22.38	0.173	22.60	0.182
		3	0	21.84	0.153	22.35	0.172	22.59	0.182
		3	2	22.02	0.159	22.50	0.178	22.58	0.181
		3	3	22.01	0.159	22.50	0.178	22.61	0.182
		6	0	21.02	0.126	21.49	0.141	21.71	0.148
	16QAM	1	0	21.04	0.127	21.64	0.146	<b>21.90</b>	<b>0.155</b>
		1	3	21.17	0.131	21.69	0.148	21.90	0.155
		1	5	21.23	0.133	21.62	0.145	21.82	0.152
		3	0	20.89	0.123	21.70	0.148	21.89	0.155
		3	2	21.05	0.127	21.79	0.151	21.83	0.152
		3	3	21.05	0.127	21.88	0.154	21.83	0.152
		6	0	20.07	0.102	20.54	0.113	20.81	0.121
LTE Band 5									
Bandwidth (MHz)	Modulation	RB Size	RB Offset	Conducted Output Power					
				20415 (825.5 MHz)		20525 (836.5 MHz)		20635 (847.5 MHz)	
				(dB m)	(W)	(dB m)	(W)	(dB m)	(W)
3	QPSK	1	0	21.84	0.153	22.38	0.173	22.60	0.182
		1	7	21.94	0.156	22.49	0.177	<b>22.90</b>	<b>0.195</b>
		1	14	22.01	0.159	22.60	0.182	22.89	0.195
		8	0	20.94	0.124	21.53	0.142	21.80	0.151
		8	4	21.08	0.128	21.66	0.147	21.79	0.151
		8	7	21.15	0.130	21.61	0.145	21.80	0.151
		15	0	20.94	0.124	21.54	0.143	21.80	0.151
	16QAM	1	0	21.10	0.129	21.59	0.144	21.84	0.153
		1	7	21.18	0.131	21.78	0.151	<b>22.20</b>	<b>0.166</b>
		1	14	21.25	0.133	21.77	0.150	22.18	0.165
		8	0	20.01	0.100	20.56	0.114	20.81	0.121
		8	4	20.14	0.103	20.71	0.118	20.80	0.120
		8	7	20.21	0.105	20.69	0.117	20.80	0.120
		15	0	20.07	0.102	20.58	0.114	20.82	0.121

LTE Band 5									
Bandwidth (MHz)	Modulation	RB Size	RB Offset	Conducted Output Power					
				20425 (826.5 MHz)		20525 (836.5 MHz)		20625 (846.5 MHz)	
				(dB m)	(W)	(dB m)	(W)	(dB m)	(W)
5	QPSK	1	0	21.83	0.152	22.42	0.175	22.61	0.182
		1	12	21.92	0.156	22.48	0.177	22.75	0.188
		1	24	21.92	0.156	22.62	0.183	<b>22.79</b>	<b>0.190</b>
		12	0	21.01	0.126	21.46	0.140	21.77	0.150
		12	6	21.17	0.131	21.55	0.143	21.87	0.154
		12	13	21.23	0.133	21.62	0.145	21.91	0.155
		25	0	21.15	0.130	21.52	0.142	21.86	0.153
	16QAM	1	0	21.12	0.129	21.59	0.144	21.94	0.156
		1	12	21.26	0.134	21.69	0.148	<b>22.09</b>	<b>0.162</b>
		1	24	21.19	0.132	21.81	0.152	21.97	0.157
		12	0	19.99	0.100	20.43	0.110	20.75	0.119
		12	6	20.19	0.104	20.61	0.115	20.89	0.123
		12	13	20.20	0.105	20.65	0.116	20.89	0.123
		25	0	20.13	0.103	20.55	0.114	20.86	0.122
LTE Band 5									
Bandwidth (MHz)	Modulation	RB Size	RB Offset	Conducted Output Power					
				20450 (829.0 MHz)		20525 (836.5 MHz)		20600 (844.0 MHz)	
				(dB m)	(W)	(dB m)	(W)	(dB m)	(W)
10	QPSK	1	0	22.07	0.161	22.41	0.174	<b>22.59</b>	<b>0.182</b>
		1	25	21.98	0.158	22.43	0.175	22.54	0.179
		1	49	22.11	0.163	22.50	0.178	22.59	0.182
		25	0	21.18	0.131	21.51	0.142	21.69	0.148
		25	12	21.22	0.132	21.57	0.144	21.77	0.150
		25	25	21.25	0.133	21.54	0.143	21.71	0.148
		50	0	21.24	0.133	21.55	0.143	21.71	0.148
	16QAM	1	0	21.13	0.130	21.53	0.142	21.86	0.153
		1	25	21.30	0.135	21.69	0.148	21.86	0.153
		1	49	21.35	0.136	21.78	0.151	<b>21.87</b>	<b>0.154</b>
		25	0	20.17	0.104	20.52	0.113	20.66	0.116
		25	12	20.25	0.106	20.61	0.115	20.76	0.119
		25	25	20.30	0.107	20.53	0.113	20.73	0.118
		50	0	20.26	0.106	20.55	0.114	20.69	0.117

LTE Band 7									
Bandwidth (MHz)	Modulation	RB Size	RB Offset	Conducted Output Power					
				20775 (2 502.5 MHz)		21100 (2 535.0 MHz)		21425 (2 567.5 MHz)	
				(dB m)	(W)	(dB m)	(W)	(dB m)	(W)
5	QPSK	1	0	22.41	0.174	<b>22.49</b>	<b>0.177</b>	22.46	0.176
		1	12	22.35	0.172	22.37	0.173	22.34	0.171
		1	24	22.37	0.173	22.33	0.171	22.36	0.172
		12	0	21.41	0.138	21.53	0.142	21.62	0.145
		12	6	21.51	0.142	21.52	0.142	21.67	0.147
		12	13	21.49	0.141	21.54	0.143	21.62	0.145
		25	0	21.48	0.141	21.54	0.143	21.61	0.145
	16QAM	1	0	21.58	0.144	<b>21.76</b>	<b>0.150</b>	21.67	0.147
		1	12	21.58	0.144	21.72	0.149	21.69	0.148
		1	24	21.66	0.147	21.66	0.147	21.69	0.148
		12	0	20.46	0.111	20.54	0.113	20.61	0.115
		12	6	20.50	0.112	20.55	0.114	20.71	0.118
		12	13	20.51	0.112	20.53	0.113	20.67	0.117
		25	0	20.49	0.112	20.54	0.113	20.67	0.117
LTE Band 7									
Bandwidth (MHz)	Modulation	RB Size	RB Offset	Conducted Output Power					
				20800 (2 505.0 MHz)		21100 (2 535.0 MHz)		21400 (2 565.0 MHz)	
				(dB m)	(W)	(dB m)	(W)	(dB m)	(W)
10	QPSK	1	0	22.38	0.173	22.43	0.175	22.35	0.172
		1	25	22.27	0.169	<b>22.47</b>	<b>0.177</b>	22.31	0.170
		1	49	22.22	0.167	22.45	0.176	22.33	0.171
		25	0	21.55	0.143	21.57	0.144	21.49	0.141
		25	12	21.51	0.142	21.53	0.142	21.45	0.140
		25	25	21.46	0.140	21.50	0.141	21.51	0.142
		50	0	21.45	0.140	21.56	0.143	21.50	0.141
	16QAM	1	0	21.63	0.146	21.70	0.148	21.69	0.148
		1	25	21.58	0.144	<b>21.81</b>	<b>0.152</b>	21.65	0.146
		1	49	21.43	0.139	21.67	0.147	21.45	0.140
		25	0	20.52	0.113	20.64	0.116	20.48	0.112
		25	12	20.51	0.112	20.60	0.115	20.45	0.111
		25	25	20.48	0.112	20.56	0.114	20.47	0.111
		50	0	20.53	0.113	20.56	0.114	20.54	0.113



LTE Band 7									
Bandwidth (MHz)	Modulation	RB Size	RB Offset	Conducted Output Power					
				20825 (2 507.5 MHz)		21100 (2 535.0 MHz)		21375 (2 562.5 MHz)	
				(dB m)	(W)	(dB m)	(W)	(dB m)	(W)
15	QPSK	1	0	22.64	0.184	<b>22.65</b>	<b>0.184</b>	22.57	0.181
		1	36	22.44	0.175	22.65	0.184	22.51	0.178
		1	74	22.56	0.180	22.64	0.184	22.46	0.176
		36	0	21.63	0.146	21.73	0.149	21.69	0.148
		36	18	21.64	0.146	21.71	0.148	21.67	0.147
		36	37	21.65	0.146	21.70	0.148	21.58	0.144
		75	0	21.57	0.144	21.69	0.148	21.64	0.146
	16QAM	1	0	21.85	0.153	<b>21.92</b>	<b>0.156</b>	21.92	0.156
		1	36	21.69	0.148	21.88	0.154	21.73	0.149
		1	74	21.81	0.152	21.92	0.156	21.81	0.152
		36	0	20.64	0.116	20.77	0.119	20.68	0.117
		36	18	20.72	0.118	20.75	0.119	20.66	0.116
		36	37	20.73	0.118	20.71	0.118	20.60	0.115
		75	0	20.57	0.114	20.73	0.118	20.68	0.117
LTE Band 7									
Bandwidth (MHz)	Modulation	RB Size	RB Offset	Conducted Output Power					
				20850 (2 510.0 MHz)		21100 (2 535.0 MHz)		21350 (2 560.0 MHz)	
				(dB m)	(W)	(dB m)	(W)	(dB m)	(W)
20	QPSK	1	0	22.52	0.179	22.62	0.183	<b>22.70</b>	<b>0.186</b>
		1	50	22.55	0.180	22.55	0.180	22.59	0.182
		1	99	22.43	0.175	22.54	0.179	22.43	0.175
		50	0	21.63	0.146	21.68	0.147	21.73	0.149
		50	25	21.66	0.147	21.76	0.150	21.67	0.147
		50	50	21.64	0.146	21.72	0.149	21.66	0.147
		100	0	21.56	0.143	21.73	0.149	21.69	0.148
	16QAM	1	0	21.75	0.150	<b>22.00</b>	<b>0.158</b>	21.84	0.153
		1	50	21.82	0.152	21.88	0.154	21.87	0.154
		1	99	21.68	0.147	21.76	0.150	21.83	0.152
		50	0	20.72	0.118	20.72	0.118	20.74	0.119
		50	25	20.68	0.117	20.79	0.120	20.68	0.117
		50	50	20.74	0.119	20.81	0.121	20.64	0.116
		100	0	20.56	0.114	20.76	0.119	20.68	0.117

LTE Band 12									
Bandwidth (MHz)	Modulation	RB Size	RB Offset	Conducted Output Power					
				23017 (699.7 MHz)		23095 (707.5 MHz)		23173 (715.3 MHz)	
				(dB m)	(W)	(dB m)	(W)	(dB m)	(W)
1.4	QPSK	1	0	22.10	0.162	22.05	0.160	21.99	0.158
		1	3	<b>22.21</b>	<b>0.166</b>	22.05	0.160	21.98	0.158
		1	5	22.12	0.163	22.02	0.159	21.97	0.157
		3	0	21.99	0.158	21.93	0.156	21.85	0.153
		3	2	22.02	0.159	22.05	0.160	21.82	0.152
		3	3	21.96	0.157	22.02	0.159	21.83	0.152
		6	0	21.13	0.130	21.12	0.129	21.01	0.126
	16QAM	1	0	21.15	0.130	21.16	0.131	21.15	0.130
		1	3	21.26	0.134	21.19	0.132	21.14	0.130
		1	5	<b>21.27</b>	<b>0.134</b>	21.14	0.130	21.07	0.128
		3	0	20.98	0.125	21.17	0.131	21.14	0.130
		3	2	21.06	0.128	21.26	0.134	21.23	0.133
		3	3	21.03	0.127	21.26	0.134	21.19	0.132
		6	0	20.18	0.104	20.19	0.104	20.03	0.101
LTE Band 12									
Bandwidth (MHz)	Modulation	RB Size	RB Offset	Conducted Output Power					
				23025 (700.5 MHz)		23095 (707.5 MHz)		23165 (714.5 MHz)	
				(dB m)	(W)	(dB m)	(W)	(dB m)	(W)
3	QPSK	1	0	21.99	0.158	21.99	0.158	21.93	0.156
		1	7	22.10	0.162	22.07	0.161	22.01	0.159
		1	14	<b>22.14</b>	<b>0.164</b>	22.02	0.159	21.93	0.156
		8	0	21.19	0.132	21.21	0.132	21.03	0.127
		8	4	21.22	0.132	21.22	0.132	21.08	0.128
		8	7	21.19	0.132	21.14	0.130	21.11	0.129
		15	0	21.09	0.129	21.21	0.132	21.04	0.127
	16QAM	1	0	21.21	0.132	21.22	0.132	21.19	0.132
		1	7	21.32	0.136	21.31	0.135	21.17	0.131
		1	14	<b>21.45</b>	<b>0.140</b>	21.33	0.136	21.23	0.133
		8	0	20.23	0.105	20.23	0.105	20.13	0.103
		8	4	20.27	0.106	20.22	0.105	20.11	0.103
		8	7	20.19	0.104	20.27	0.106	20.12	0.103
		15	0	20.19	0.104	20.19	0.104	20.03	0.101

LTE Band 12/17									
Bandwidth (MHz)	Modulation	RB Size	RB Offset	Conducted Output Power					
				23035 (701.5 MHz)		23095 (707.5 MHz)		23155 (713.5 MHz)	
				(dB m)	(W)	(dB m)	(W)	(dB m)	(W)
5	QPSK	1	0	21.98	0.158	21.93	0.156	21.96	0.157
		1	12	<b>22.08</b>	<b>0.161</b>	22.02	0.159	21.94	0.156
		1	24	22.01	0.159	22.03	0.160	21.93	0.156
		12	0	21.15	0.130	21.12	0.129	21.03	0.127
		12	6	21.22	0.132	21.21	0.132	21.06	0.128
		12	13	21.16	0.131	21.13	0.130	21.04	0.127
		25	0	21.14	0.130	21.14	0.130	21.03	0.127
	16QAM	1	0	21.26	0.134	21.22	0.132	21.23	0.133
		1	12	<b>21.34</b>	<b>0.136</b>	21.27	0.134	21.21	0.132
		1	24	21.19	0.132	21.26	0.134	21.17	0.131
		12	0	20.12	0.103	20.09	0.102	20.08	0.102
		12	6	20.22	0.105	20.22	0.105	20.06	0.101
		12	13	20.12	0.103	20.11	0.103	20.09	0.102
		25	0	20.18	0.104	20.17	0.104	20.03	0.101
LTE Band 12/17									
Bandwidth (MHz)	Modulation	RB Size	RB Offset	Conducted Output Power					
				23060 (704.0 MHz)		23095 (707.5 MHz)		23130 (711.0 MHz)	
				(dB m)	(W)	(dB m)	(W)	(dB m)	(W)
10	QPSK	1	0	<b>22.12</b>	<b>0.163</b>	22.07	0.161	21.99	0.158
		1	25	22.02	0.159	21.92	0.156	21.97	0.157
		1	49	21.96	0.157	21.99	0.158	21.85	0.153
		25	0	21.12	0.129	21.13	0.130	21.16	0.131
		25	12	21.14	0.130	21.15	0.130	21.09	0.129
		25	25	21.07	0.128	21.11	0.129	21.07	0.128
		50	0	21.12	0.129	21.17	0.131	21.06	0.128
	16QAM	1	0	<b>21.38</b>	<b>0.137</b>	21.31	0.135	21.32	0.136
		1	25	21.24	0.133	21.23	0.133	21.22	0.132
		1	49	21.23	0.133	21.23	0.133	21.08	0.128
		25	0	20.17	0.104	20.13	0.103	20.12	0.103
		25	12	20.15	0.104	20.17	0.104	20.15	0.104
		25	25	20.09	0.102	20.15	0.104	20.07	0.102
		50	0	20.16	0.104	20.14	0.103	20.13	0.103

LTE Band 13									
Bandwidth (MHz)	Modulation	RB Size	RB Offset	Conducted Output Power					
				23205 (779.5 MHz)		23230 (782.0 MHz)		23255 (784.5 MHz)	
				(dB m)	(W)	(dB m)	(W)	(dB m)	(W)
5	QPSK	1	0	<b>22.05</b>	<b>0.160</b>	22.02	0.159	21.89	0.155
		1	12	21.95	0.157	21.96	0.157	21.84	0.153
		1	24	21.91	0.155	21.94	0.156	21.79	0.151
		12	0	21.03	0.127	20.90	0.123	21.02	0.126
		12	6	21.05	0.127	20.89	0.123	21.01	0.126
		12	13	21.01	0.126	20.95	0.124	20.91	0.123
		25	0	21.03	0.127	20.90	0.123	20.96	0.125
	16QAM	1	0	<b>21.17</b>	<b>0.131</b>	21.16	0.131	21.16	0.131
		1	12	21.17	0.131	21.12	0.129	21.17	0.131
		1	24	21.11	0.129	21.15	0.130	21.14	0.130
		12	0	20.01	0.100	19.95	0.099	20.07	0.102
		12	6	20.01	0.100	19.97	0.099	20.04	0.101
		12	13	19.98	0.100	19.94	0.099	19.99	0.100
		25	0	20.08	0.102	19.97	0.099	19.98	0.100
LTE Band 13									
Bandwidth (MHz)	Modulation	RB Size	RB Offset	Conducted Output Power					
						23230 (782.0 MHz)			
						(dB m)	(W)		
10	QPSK	1	0	-	-	<b>22.04</b>	<b>0.160</b>	-	-
		1	25	-	-	21.84	0.153	-	-
		1	49	-	-	21.85	0.153	-	-
		25	0	-	-	21.01	0.126	-	-
		25	12	-	-	20.98	0.125	-	-
		25	25	-	-	20.96	0.125	-	-
		50	0	-	-	20.97	0.125	-	-
	16QAM	1	0	-	-	<b>21.20</b>	<b>0.132</b>	-	-
		1	25	-	-	21.08	0.128	-	-
		1	49	-	-	20.96	0.125	-	-
		25	0	-	-	20.02	0.100	-	-
		25	12	-	-	19.98	0.100	-	-
		25	25	-	-	19.95	0.099	-	-
		50	0	-	-	20.04	0.101	-	-

## 4. Occupied Bandwidth

### 4.1. Limit

CFR 47, Section FCC §2.1049 and IC RSS-Gen Issue 5 6.7.

### 4.2. Test Procedure

#### FCC

The test follows section 5.4.4 of ANSI C63.26-2015.

- a. The spectrum analyzer center frequency is set to the nominal EUT channel center frequency. The frequency span for the spectrum analyzer shall be set wide enough to capture all modulation. products including the emission skirts (typically a span of  $1.5 \times \text{OBW}$  is sufficient).
- b. The nominal IF filter 3 dB bandwidth (RBW) shall be in the range of 1 % to 5 % of the anticipated OBW, and the VBW shall be set  $\geq 3 \times \text{RBW}$ .
- c. Set the reference level of the instrument as required to prevent the signal amplitude from exceeding the maximum spectrum analyzer input mixer level for linear operation. See guidance provided in 4.2.3.
- d. Set the detection mode to peak, and the trace mode to max-hold.
- e. If the instrument does not have a 99 % OBW function, recover the trace data points and sum directly in linear power terms. Place the recovered amplitude data points, beginning at the lowest frequency, in a running sum until 0.5 % of the total is reached. Record that frequency as the lower OBW frequency. Repeat the process until 99.5 % of the total is reached and record that frequency as the upper OBW frequency. The 99 % power OBW can be determined by computing the difference these two frequencies.
- f. The OBW shall be reported and plot(s) of the measuring instrument display shall be provided with the test report. The frequency and amplitude axis and scale shall be clearly labeled. Tabular data can be reported in addition to the plot(s).

**IC**

The test follows section 6.7 of RSS-Gen Issue 5.

The following conditions shall be observed for measuring the occupied bandwidth and  $x$  dB bandwidth:

- The transmitter shall be operated at its maximum carrier power measured under normal test conditions.
- The span of the spectrum analyzer shall be set large enough to capture all products of the modulation process, including the emission skirts, around the carrier frequency, but small enough to avoid having other emissions (e.g. on adjacent channels) within the span.
- The detector of the spectrum analyzer shall be set to "Sample". However, a peak, or peak hold, may be used in place of the sampling detector since this usually produces a wider bandwidth than the actual bandwidth (worst-case measurement). Use of a peak hold (or "Max Hold") may be necessary to determine the occupied /  $x$  dB bandwidth if the device is not transmitting continuously.
- The resolution bandwidth (RBW) shall be in the range of 1 % to 5 % of the actual occupied /  $x$  dB bandwidth and the video bandwidth (VBW) shall not be smaller than three times the RBW value. Video averaging is not permitted.

Note: It may be necessary to repeat the measurement a few times until the RBW and VBW are in compliance with the above requirement.

For the 99 % emission bandwidth, the trace data points are recovered and directly summed in linear power level terms. The recovered amplitude data points, beginning at the lowest frequency, are placed in a running sum until 0.5 % of the total is reached, and that frequency recorded. The process is repeated for the highest frequency data points (starting at the highest frequency, at the right side of the span, and going down in frequency). This frequency is then recorded. The difference between the two recorded frequencies is the occupied bandwidth (or the 99 % emission bandwidth).

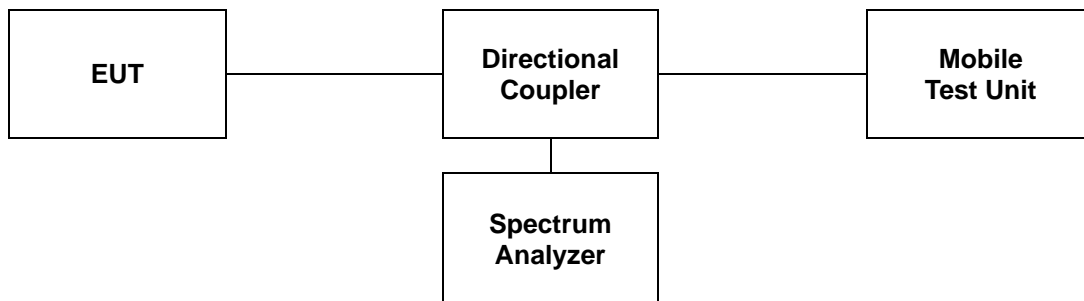

### 4.3 Test Results

Ambient temperature : (23 ± 1) °C  
 Relative humidity : 47 ± 2 %

Band	Bandwidth (MHz)	Frequency (MHz)	Occupied Bandwidth (MHz)		
			QPSK	16QAM	
2	1.4	1 880.0	1.094	1.094	
	3		2.673	2.679	
	5		4.496	4.505	
	10		8.931	8.931	
	15		13.427	13.457	
	20		17.902	17.902	
66/4	1.4	1 745.0	1.088	1.094	
	3		2.673	2.679	
	5		4.486	4.476	
	10		8.951	8.931	
	15		13.427	13.427	
	20		17.902	17.902	
5	1.4	836.5	1.094	1.091	
	3		2.673	2.673	
	5		4.496	4.496	
	10		8.951	8.931	
7	5	2 535.0	4.496	4.496	
	10		8.931	8.911	
	15		13.427	13.457	
	20		17.902	17.902	
12	1.4	707.5	1.091	1.091	
	3		2.673	2.679	
12/17	5		4.496	4.505	
	10		8.971	8.931	
13	5		782.0	4.505	4.486
	10			8.911	8.911