

TEST REPORT

of

FCC Part 2 Subpart J, Part 22 Subpart C/H,
Part 24 Subpart E

FCC ID: YZP-GN3000

Equipment Under Test : Telematics Module

Model Name : LTD-GN3000

Variant Model Name(s) : -

Applicant : LG Innotek Co., Ltd.

Manufacturer : LG Innotek Co., Ltd.

Date of Receipt : 2024.02.15

Date of Test(s) : 2024.02.16 ~ 2024.08.28

Date of Issue : 2024.10.07

In the configuration tested, the EUT complied with the standards specified above. This test report does not assure KOLAS accreditation.

- 1) The results of this test report are effective only to the items tested.
- 2) The SGS Korea is not responsible for the sampling, the results of this test report apply to the sample as received.
- 3) This test report cannot be reproduced, except in full, without prior written permission of the Company.
- 4) The data marked ※ in this report was provided by the customer and may affect the validity of the test results.

We are responsible for all the information of this test report except for the data(※) provided by the customer.

Tested by:



Dave Kim

Technical
Manager:



Patrick Kang

SGS Korea Co., Ltd. Gunpo Laboratory



INDEX

<u>Table of Contents</u>	Page
1. General Information -----	3
2. E.R.P. / E.I.R.P. & Radiated Spurious Emissions -----	10
3. Conducted Output Power -----	19
4. Occupied Bandwidth -----	22
5. Peak-Average Ratio -----	25
6. Spurious Emissions at Antenna Terminal -----	30
7. Band Edge -----	34
8. Frequency Stability -----	38

1. General Information

1.1. Testing Laboratory

SGS Korea Co., Ltd. (Gunpo Laboratory)

- 10-2, LS-ro 182beon-gil, Gunpo-si, Gyeonggi-do, Korea, 15807
- 4, LS-ro 182beon-gil, Gunpo-si, Gyeonggi-do, Korea, 15807
- Designation number: KR0150

All SGS services are rendered in accordance with the applicable SGS conditions of service available on request and accessible at <http://www.sgs.com/en/Terms-and-Conditions.aspx>.

Phone No. : +82 31 688 0901

Fax No. : +82 31 688 0921

1.2. Details of Applicant

Applicant : LG Innotek Co., Ltd.

Address : 30 Magokjungang 10-ro, Gangseo-gu, seoul, Republic Of Korea, 07996

Contact Person : Jeong, In-chang

Phone No. : +82 10 2326 9972

1.3. Details of Manufacturer

Company : Same as applicant

Address : Same as applicant

Factory1 : PT. LG INNOTEK INDONESIA

Factory1 Adress : Bekasi International Industrial Estate, Blok C8 No. 12 & 12A, Desa Cibatu, Cikarang Selatan, Bekasi 17750, Jawa Barat - Indonesia

Factory2 : LG Innotek Co., Ltd.

Factory2 Adress : 26, Hanamsandan 5beon-ro, Gwangsan-gu, Gwangju, Republic of Korea, 62229

1.4. Description of EUT

Kind of Product	Telematics Module
Model Name	LTD-GN3000
Serial Number	Conducted: C1 Radiated: R1
Power Supply	DC 4.00 V
Rated Power	WCDMA V: 24 dB m GSM 850: 33 dB m GSM 1900: 30 dB m
Frequency Range	WCDMA V: 824 MHz ~ 849 MHz GSM 850: 824 MHz ~ 849 MHz GSM 1900: 1 850 MHz ~ 1 910 MHz
Modulation Technique	BPSK, QPSK, GMSK, 8PSK
Antenna Type	Dipole Antenna
Antenna Gain*	824 MHz ~ 849 MHz: 1.99 dB i 1 850 MHz ~ 1 910 MHz: 1.90 dB i
H/W Version	A.4
S/W Version	01N_TCM

1.5. Test Equipment List

Equipment	Manufacturer	Model	S/N	Cal. Date	Cal. Interval	Cal. Due
Spectrum Analyzer	R&S	FSV30	100955	Mar. 08, 2024	Annual	Mar. 08, 2025
Spectrum Analyzer	Agilent	N9030A	US51350132	Nov. 27, 2023	Annual	Nov. 27, 2024
Signal Generator	R&S	SMA100B	106887	Oct. 06, 2023	Annual	Oct. 06, 2024
DC Power Supply	R&S	HMP2020	102133	Apr. 23, 2024	Annual	Apr. 23, 2025
Mobile Test Unit	R&S	CMW 500	144034	Feb. 28, 2024	Annual	Feb. 28, 2025
Temperature Chamber	ESPEC CORP.	PL-2J	15004184	Jun. 03, 2024	Annual	Jun. 03, 2025
BRIDGE COUPLER	MARKI MICROWAVE INC	CBR16-0012	1542	May 13, 2024	Annual	May 13, 2025
Directional Coupler	KRYTAR	152613	140973	Jun. 07, 2024	Annual	Jun. 07, 2025
Power Sensor	Anritsu	MA2411B	1207272	May 29, 2024	Annual	May 29, 2025
Power Sensor	Anritsu	ML2495A	1223004	May 29, 2024	Annual	May 29, 2025
Low Pass Filter	Mini-Circuits	NLP-1200+	V 8979400903-1	May 17, 2024	Annual	May 17, 2025
High Pass Filter	Wainwright Instrument GmbH	WHKX10-900-1000-18000-40SS	7	Feb. 27, 2024	Annual	Feb. 27, 2025
High Pass Filter	Wainwright Instrument GmbH	WHKX3.0/18G-6SS	21	Jun. 07, 2024	Annual	Jun. 07, 2025
High Pass Filter	Wainwright Instrument GmbH	WHNX7.5/26.5G-6SS	11	Oct. 17, 2023	Annual	Oct. 17, 2024
Preamplifier	H.P.	8447F	2944A03909	Aug. 04, 2023	Annual	Aug. 09, 2025
Preamplifier	R&S	SCU 18F	101058	Dec. 07, 2023	Annual	Dec. 07, 2024
Preamplifier	MITEQ Inc.	JS44-18004000-35-8P	1546891	Oct. 06, 2023	Annual	Oct. 06, 2024
Test Receiver	R&S	ESU26	100109	Jan. 16, 2024	Annual	Jan. 16, 2025
Loop Antenna	Schwarzbeck Mess-Elektronik	FMZB 1519	1519-039	Aug. 21, 2023	Biennial	Aug. 21, 2025
Bilog Antenna	Schwarzbeck Mess-Elektronik	VULB9163	9163-437	May 29, 2024	Annual	May 29, 2025
Horn Antenna	R&S	HF906	100326	Feb. 19, 2024	Annual	Feb. 19, 2025
Horn Antenna	Schwarzbeck Mess-Elektronik	BBHA 9170	9170-540	Dec. 05, 2023	Annual	Dec. 05, 2024
Antenna Master	Innco systems GmbH	MA4640-XP-ET	MA4640/536/383 30516/L	N.C.R.	N/A	N.C.R.
Turn Table	Innco systems GmbH	DS 1200S	N/A	N.C.R.	N/A	N.C.R.
Controller	Innco systems GmbH	CONTROLLER CO3000-4P	CO3000/963/383 30516/L	N.C.R.	N/A	N.C.R.
Anechoic Chamber	SY Corporation	L x W x H (9.6 m x 6.4 m x 6.6 m)	N/A	N.C.R.	N/A	N.C.R.
Coaxial Cable	RADIALL	TESTPRO 3	182287	Apr. 12, 2024	Semi-Annual	Oct. 12, 2024
Coaxial Cable	RADIALL	TESTPRO 3	182288	Apr. 12, 2024	Semi-Annual	Oct. 12, 2024
Coaxial Cable	RADIALL	TESTPRO 3	182291	Apr. 12, 2024	Semi-Annual	Oct. 12, 2024
Coaxial Cable	SENSORVIEW	NMST-13A26-NMST-5 m	TPC2402190004	Apr. 03, 2024	Semi-Annual	Oct. 03, 2024
Coaxial Cable	SENSORVIEW	NMST-13A26-NMST-10 m	TPC2402190001	Apr. 03, 2024	Semi-Annual	Oct. 03, 2024

Note;

- For equipment listed above that has a calibration date or calibration due date that falls within the test date range, care was taken to ensure that this equipment was used after the calibration date and before the calibration due date.
- Equipment after the calibration due date was not used for testing.

1.6. Summary of Test Results

The EUT has been tested according to the following specifications:

APPLIED STANDARD: FCC Part 2, 22 and 24		
Section(s)	Test Item	Result
§2.1046 §22.913(a)(5) §24.232(c)	E.R.P. / E.I.R.P.	Complied
§2.1053 §22.917(a) §24.238(a)	Radiated Spurious Emissions	Complied
§2.1046	Conducted Output Power	Complied
§2.1049	Occupied Bandwidth	Complied
§22.913(d) §24.232(d) §27.50(d)(5)	Peak-Average Ratio	Complied
§2.1051 §22.917(a) §24.238(a)	Spurious Emission at Antenna Terminal	Complied
§22.917(a) §24.238(a)	Band Edge	Complied
§2.1055 §22.355 §24.235	Frequency Stability	Complied

1.7. Sample Calculation for Offset

Where relevant, the following sample calculation is provided:

1.7.1. Conducted Test

Offset value (dB) = Directional Coupler (dB) + Cable loss (dB)

1.7.2. Radiation test

- E.I.R.P. (dB m) = Measured level (dB μ V) + Antenna factor (dB/m) + Cable loss (dB) + 20 Log D - 104.8;
 where D is the measurement distance in meters.
- E.R.P (dB m) = E.I.R.P. (dB m) - 2.15 (dB)

1.8. Worst Case Configuration and Mode

GSM

The worst-case is based on the average conducted output power measurement investigation results. output power measurements were measured on GSM, GPRS, EDGE Mode. All testing was performed using GSM and EDGE mode, except frequency stability, spurious radiated emission spurious and emission at antenna terminal were tested only GSM mode as worst case.

The radiated test of the EUT was investigated in three orthogonal orientations X, Y, and Z, and the worst case data is reported.

WCDMA

The worst-case is based on the average conducted output power measurement investigation results. output power measurements were measured on RMC, HSDPA, HSUPA, HSPA+ and DC-HSPA Modulation. All testing was performed using RMC and HSDPA modulations, except spurious radiated emission spurious and emission at antenna terminal were tested only RMC modulation as worst case. The worst-case is based on the average conducted output power measurement investigation results.

The radiated test of the EUT was investigated in three orthogonal orientations X, Y, and Z, and the worst case data is reported.

1.9. Measurement Configuration

Test Items	Band	Test Channel			Modulation				
		Low	Mid	High	RMC	HSUPA	HSDPA	DC-HSPA	HSPA+
Conducted Output Power	WCDMA Band V	V	V	V	V	V	V	V	V
Frequency Stability	WCDMA Band V	-	V	-	V	-	-	-	-
Occupied Bandwidth	WCDMA Band V	-	V	-	V	-	V	-	-
Peak to Average Ratio	WCDMA Band V	V	V	V	V	-	V	-	-
Band Edge	WCDMA Band V	V	-	V	V	-	V	-	-
Spurious Emission at Antenna Terminal and Radiated Spurious Emissions	WCDMA Band V	Worst case							

Test Items	Band	Test Channel			Modulation		
		Low	Mid	High	VOICE	GPRS	EGPRS
Conducted Output Power	GSM 850	V	V	V	V	V	V
	GSM 1900	V	V	V	V	V	V
Frequency Stability	GSM 850	-	V	-	V	-	-
	GSM 1900	-	V	-	V	-	-
Occupied Bandwidth	GSM 850	-	V	-	V	-	V
	GSM 1900	-	V	-	V	-	V
Peak to Average Ratio	GSM 850	V	V	V	V	-	V
	GSM 1900	V	V	V	V	-	V
Band Edge	GSM 850	V	-	V	V	-	V
	GSM 1900	V	-	V	V	-	V
Spurious Emission at Antenna Terminal and Radiated Spurious Emissions	GSM 850	Worst case					
	GSM 1900	Worst case					

1.10. Measurement Uncertainty

Where relevant, the following measurement uncertainty levels have been estimated for tests performed on the apparatus:

Parameter	Uncertainty	
Conducted Output Power	0.33 dB	
Occupied Bandwidth	0.05 MHz	
Conducted Spurious Emissions	0.99 dB	
Peak to Average Ratio	0.66 dB	
Frequency Stability	116 Hz	
Radiated Emission, 9 kHz to 30 MHz	H	3.60 dB
	V	3.60 dB
Radiated Emission, below 1 GHz	H	4.60 dB
	V	4.90 dB
Radiated Emission, above 1 GHz	H	3.90 dB
	V	3.80 dB

All measurement uncertainty values are shown with a coverage factor of $k=2$ to indicate a 95 % level of confidence.

1.11. Test Report Revision

Revision	Report Number	Date of Issue	Description
0	F690501-RF-RTL005287	2024.08.28	Initial
1	F690501-RF-RTL005287-1	2024.10.07	Software version information changed

1.12. Emission Designator and Max Power

WCDMA

Band	Modulation	Low Freq. (MHz)	Upper Freq. (MHz)	Conducted Power (dB m)	Ant. Gain (dB i)	E.R.P. / E.I.R.P. Average (dB m)	E.R.P. / E.I.R.P. Average (W)	Emission Designator
WCDMA V	RMC	826.4	846.6	23.65	1.99	23.49	0.223	4M16F9W
	HSDPA			22.66		22.50	0.178	4M16F9W

GSM

Band	Modulation	Low Freq. (MHz)	Upper Freq. (MHz)	Conducted Power (dB m)	Ant. Gain (dB i)	E.R.P. / E.I.R.P. Average (dB m)	E.R.P. / E.I.R.P. Average (W)	Emission Designator
GSM 850	VOICE	824.2	848.8	32.95	1.99	23.76	0.238	232KGXW
	EDGE			32.85		23.66	0.232	239KG7W
GSM 1900	VOICE	1 850.2	1 909.8	29.11	1.90	21.98	0.158	240KGXW
	EDGE			29.10		21.97	0.157	242KG7W

2. E.R.P / E.I.R.P. & Radiated Spurious Emissions

2.1. Test setup

The diagram below shows the test setup that is utilized to make the measurements for emission from 9 kHz to 30 MHz.

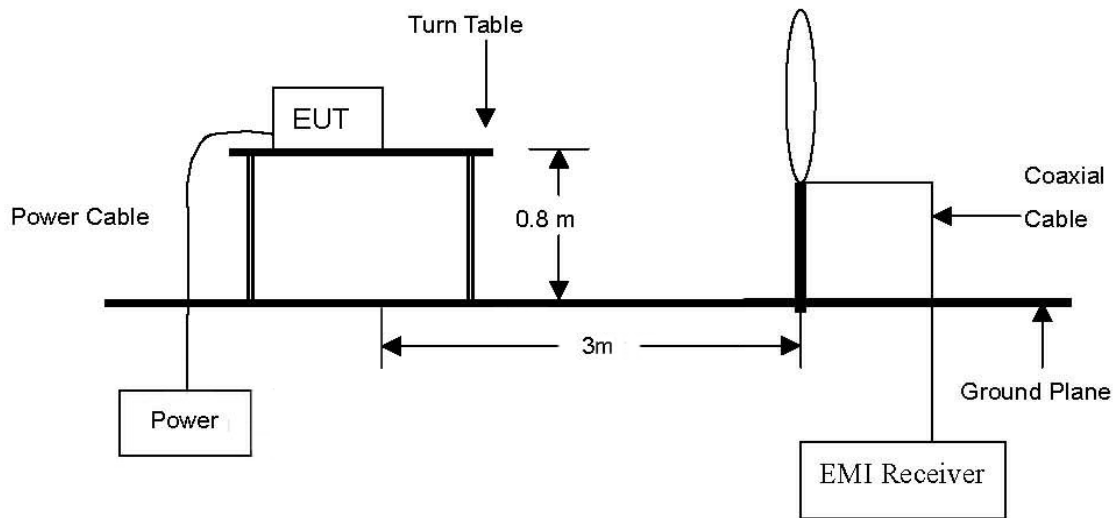

The diagram below shows the test setup that is utilized to make the measurements for emission from 30 MHz to 1 GHz Emissions.

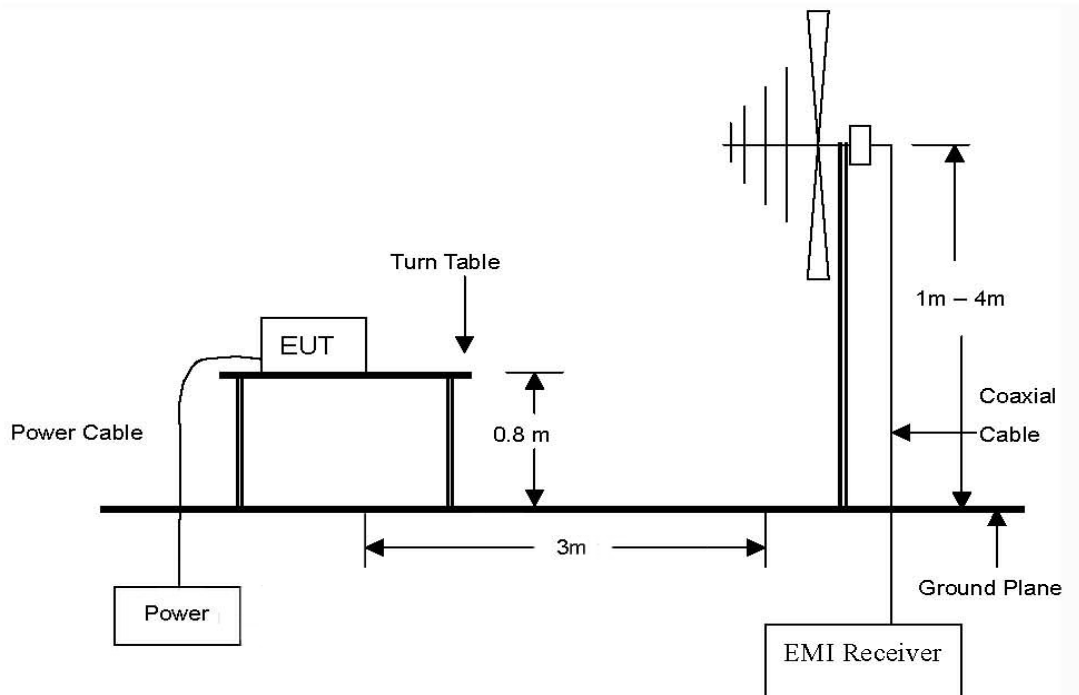

The diagram below shows the test setup that is utilized to make the measurements for emission from 1 GHz to 20 GHz Emissions.

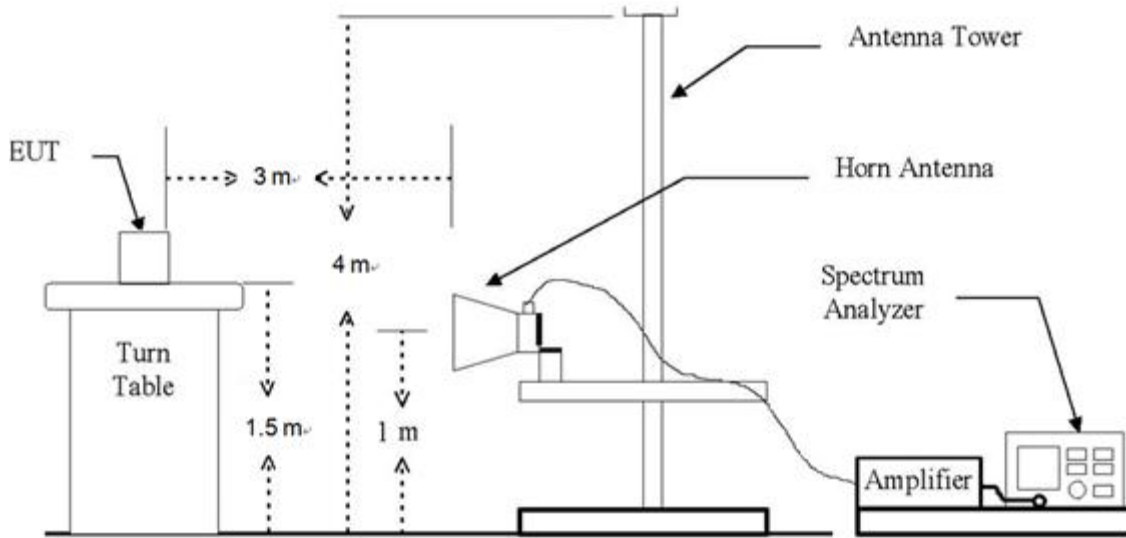

2.2. Limit

2.2.1. Limit of E.R.P. / E.I.R.P.

- §22.913(a)(5), the ERP of mobile transmitters and auxiliary test transmitters must not exceed 7 watts.
- §24.232(c), mobile and portable stations are limited to 2 watts EIRP and the equipment must employ a means for limiting power to the minimum necessary for successful communications.

2.2.2. Limit of Radiated Spurious Emissions

- §22.917(a), the power of any emission outside of the authorized operating frequency ranges must be attenuated below the transmitting power (P) by a factor of at least $43 + 10\log(P)$ dB.
- §24.238(a), the power of any emission outside of the authorized operating frequency ranges must be attenuated below the transmitting power (P) by a factor of at least $43 + 10 \log(P)$ dB.

2.3. Test Procedure

2.3.1. E.R.P. or E.I.R.P. from conducted RF output power

According to subclause 5.2.5.5 of ANSI C63.26-2015 E.R.P. and E.I.R.P. are defined as the product of the power supplied to the antenna and its gain.

The relevant equation for determining the E.R.P. or E.I.R.P. from the conducted RF output power measured using the guidance provided above is:

$$E.R.P. \text{ or } E.I.R.P. = P_{Meas} + G_T$$

where:

E.R.P. or E.I.R.P. = effective radiated power or equivalent isotropically radiated power, respectively (expressed in the same units as P_{Meas} , typically dBW or dBm);

P_{Meas} = measured transmitter output power or PSD, in dBm or dBW;

G_T = gain of the transmitting antenna, in dBd (ERP) or dBi (EIRP);

2.3.2. Radiated Spurious Emissions

The test based on ANSI/TIA 603E: 2016 and ANSI C63.26-2015 and KDB 971168 D01 Power Meas License Digital Systems v03r01.

1. On a test site, the EUT shall be placed at 0.8 m or 1.5 m height on a turn table, and in the position close to normal use as declared by the applicant.
2. The test antenna shall be oriented initially for vertical polarization located 3 m from EUT to correspond to the fundamental frequency of the transmitter.
3. The output of the test antenna shall be connected to the measuring receiver and the peak detector is used for the measurement.
4. Radiated spurious emissions measurement method was set as follows:
 RBW = 100 kHz for emissions below 1 GHz and 1 MHz for emissions above 1 GHz, VBW \geq 3 x RBW,
 Detector = RMS, trace mode = max hold, per the guidelines of KDB 971168 D01 Power Meas License Digital Systems v03r01.
5. The transmitter shall be switched on, the measuring receiver shall be tuned to the frequency of the transmitter under test.
6. The test antenna shall be raised and lowered through the specified range of height until the maximum signal level is detected by the measuring receiver.
7. The transmitter shall be rotated through 360° in the horizontal plane, until the maximum signal level is detected by the measuring receiver.
8. The test antenna shall be raised and lowered again through the specified range of height until the maximum signal level is detected by the measuring receiver.
9. The maximum signal level detected by the measuring receiver shall be noted.
10. In necessary, the input attenuator setting on the measuring receiver shall be adjusted in order to increase the sensitivity of the measuring receiver.
11. The test antenna shall be raised and lowered through the specified range of height to ensure that the maximum signal is received.
12. The measurement shall be repeated with the test antenna orientated for horizontal polarization.

2.4. Test results

Ambient temperature : (23 ± 1) °C
 Relative humidity : 47 % R.H.

2.4.1. E.R.P. / E.I.R.P.

WCDMA

Band	Frequency (MHz)	Maximum Conducted Power (dB m)	Maximum Conducted Power (W)	Antenna Gain (dB i)	Maximum E.I.R.P. (dB m)	Maximum E.I.R.P. (W)	Maximum E.R.P. (dB m)	Maximum E.R.P. (W)	Limit
WCDMA V	824 ~ 849	23.65	0.232	1.99	25.64	0.366	23.49	0.223	7 W E.R.P.

GSM

Band	Frequency (MHz)	Maximum Conducted Power (dB m)	Maximum Conducted Power (W)	Antenna Gain (dB i)	Maximum E.I.R.P. (dB m)	Maximum E.I.R.P. (W)	Maximum E.R.P. (dB m)	Maximum E.R.P. (W)	Limit
GSM 850	824 ~ 849	32.95	1.972	1.99	23.76	0.238			7 W E.R.P.
GSM 1900	1 850 ~ 1 910	29.11	0.815	1.90			21.98	0.158	2 W E.I.R.P.

Remark;

1. E.I.R.P. (dB m) = Maximum Conducted Average Power (dB m) + Antenna Gain (dB i)
2. E.R.P. (dB m) = E.I.R.P. (dB m) - 2.15 (dB); where E.R.P. and E.I.R.P. are expressed in consistent units.

2.4.2. Radiated Spurious Emissions

WCDMA V

Frequency (MHz)	Measured Level (dB μ V)	Ant. Pol.	AF (dB/m)	AMP+CL (dB)	E (dB μ V/m)	CF (dB)	E.R.P. (dB m)	Limit (dB m)	Margin (dB)
Low Channel (826.4 MHz)									
1 651.52	52.21	H	25.83	-36.59	41.45	-97.41	-55.96	-13	42.96
1 654.32	45.64	V	25.88	-36.53	34.99	-97.41	-62.42	-13	49.42
2 476.20	79.77	H	28.30	-33.05	75.02	-97.41	-22.40	-13	9.40
2 475.25	77.15	V	28.30	-32.99	72.46	-97.41	-24.95	-13	11.95
3 301.00	44.94	H	31.00	-32.90	43.04	-97.41	-54.37	-13	41.37
3 302.25	43.04	V	31.00	-32.91	41.13	-97.41	-56.28	-13	43.28
4 129.90	53.33	H	32.10	-29.63	55.80	-97.41	-41.61	-13	28.61
4 126.55	53.38	V	32.10	-29.47	56.01	-97.41	-41.40	-13	28.40
5 781.20	52.13	H	34.26	-28.29	58.10	-97.41	-39.32	-13	26.32
5 781.35	45.82	V	34.26	-28.27	51.81	-97.41	-45.60	-13	32.60
Above 5 800.00	Not detected	-	-	-	-	-	-	-	-
Middle Channel (836.6 MHz)									
1 675.18	51.77	H	26.25	-36.18	41.84	-97.41	-55.57	-13	42.57
1 670.60	44.86	V	26.17	-36.26	34.77	-97.41	-62.64	-13	49.64
2 509.90	79.67	H	28.44	-34.37	73.74	-97.41	-23.67	-13	10.67
2 509.45	77.37	V	28.44	-34.37	71.44	-97.41	-25.97	-13	12.97
3 343.55	42.11	H	31.00	-32.80	40.31	-97.41	-57.10	-13	44.10
3 343.35	41.01	V	31.00	-32.81	39.20	-97.41	-58.21	-13	45.21
4 180.00	54.27	H	32.10	-31.25	55.12	-97.41	-42.29	-13	29.29
4 181.20	54.86	V	32.10	-31.25	55.71	-97.41	-41.70	-13	28.70
5 855.15	52.65	H	34.42	-28.76	58.31	-97.41	-39.10	-13	26.10
5 853.45	43.82	V	34.41	-28.78	49.45	-97.41	-47.96	-13	34.96
Above 5 900.00	Not detected	-	-	-	-	-	-	-	-

Frequency (MHz)	Measured Level (dB μ V)	Ant. Pol.	AF (dB/m)	AMP+CL (dB)	E (dB μ V/m)	CF (dB)	E.R.P. (dB m)	Limit (dB m)	Margin (dB)
High Channel (846.6 MHz)									
1 690.88	50.96	H	26.54	-36.24	41.26	-97.41	-56.15	-13	43.15
1 690.62	47.15	V	26.53	-36.24	37.44	-97.41	-59.97	-13	46.97
2 539.15	68.64	H	28.56	-33.97	63.23	-97.41	-34.18	-13	21.18
2 539.75	66.64	V	28.56	-33.96	61.24	-97.41	-36.17	-13	23.17
3 381.80	41.42	H	31.00	-32.64	39.78	-97.41	-57.63	-13	44.63
3 380.70	39.76	V	31.00	-32.67	38.09	-97.41	-59.32	-13	46.32
4 232.50	48.22	H	32.10	-29.22	51.10	-97.41	-46.31	-13	33.31
4 234.10	48.25	V	32.10	-29.33	51.02	-97.41	-46.40	-13	33.40
5 925.75	49.48	H	34.60	-27.60	56.48	-97.41	-40.93	-13	27.93
5 922.50	39.38	V	34.60	-27.50	46.48	-97.41	-50.93	-13	37.93
Above 6 000.00	Not detected	-	-	-	-	-	-	-	-

GSM 850_VOICE

Frequency (MHz)	Measured Level (dB μ V)	Ant. Pol.	AF (dB/m)	AMP+CL (dB)	E (dB μ V/m)	CF (dB)	E.R.P. (dB m)	Limit (dB m)	Margin (dB)
Low Channel (824.2 MHz)									
1 648.49	60.13	H	25.79	-36.60	49.32	-97.41	-48.09	-13	35.09
1 648.44	57.45	V	25.79	-36.60	46.64	-97.41	-50.77	-13	37.77
2 472.42	73.89	H	28.29	-33.10	69.08	-97.41	-28.34	-13	15.34
2 472.36	68.64	V	28.29	-33.10	63.83	-97.41	-33.58	-13	20.58
Above 2 500.00	Not detected	-	-	-	-	-	-	-	-
Middle Channel (836.6 MHz)									
1 673.03	59.10	H	26.21	-36.21	49.10	-97.41	-48.31	-13	35.31
1 673.22	59.65	V	26.22	-36.21	49.66	-97.41	-47.75	-13	34.75
2 509.66	70.67	H	28.44	-34.37	64.74	-97.41	-32.67	-13	19.67
2 509.81	65.72	V	28.44	-34.37	59.79	-97.41	-37.62	-13	24.62
Above 2 600.00	Not detected	-	-	-	-	-	-	-	-
High Channel (848.8 MHz)									
1 697.53	56.65	H	26.66	-36.26	47.05	-97.41	-50.36	-13	37.36
1 697.70	58.13	V	26.66	-36.26	48.53	-97.41	-48.88	-13	35.88
2 546.56	71.73	H	28.59	-33.79	66.53	-97.41	-30.89	-13	17.89
2 546.46	65.54	V	28.59	-33.79	60.34	-97.41	-37.07	-13	24.07
Above 2 600.00	Not detected	-	-	-	-	-	-	-	-

GSM 1900_VOICE

Frequency (MHz)	Measured Level (dB μ V)	Ant. Pol.	AF (dB/m)	AMP+CL (dB)	E (dB μ V/m)	CF (dB)	E.I.R.P. (dB m)	Limit (dB m)	Margin (dB)
Low Channel (1 850.2 MHz)									
Below 1 000.00	Not detected	-	-	-	-	-	-	-	-
Above 1 000.00	Not detected	-	-	-	-	-	-	-	-
Middle Channel (1 880.0 MHz)									
Below 1 000.00	Not detected	-	-	-	-	-	-	-	-
Above 1 000.00	Not detected	-	-	-	-	-	-	-	-
High Channel (1 909.8 MHz)									
Below 1 000.00	Not detected	-	-	-	-	-	-	-	-
Above 1 000.00	Not detected	-	-	-	-	-	-	-	-

Remark;

1. AF = Antenna Factor, CL = Cable Loss, CF = Conversion Factor.
2. E (dB μ V/m) = Measured Level (dB μ V) + Antenna Factor (dB/m) + Cable Loss (dB) + AMP (dB).
3. E.I.R.P. (dB m) = E (dB μ V/m) + CF (dB).
4. E.R.P. (dB m) = E (dB μ V/m) + CF (dB) - 2.15 (dB); where E.R.P. and E.I.R.P. are expressed in consistent units.
5. CF (dB) = 20 log D - 104.8; where D is the measurement distance in meters, According to ANSI C63.26-2015 5.2.7 and KDB 971168 D01 v03r01 5.8.4
6. The frequency spectrum is examined from 9 kHz to the 10th harmonic of the fundamental frequency of the transmitter. No other spurious and harmonic emissions were reported greater than listed emissions above table.

3. Conducted Output Power

3.1. Limit

CFR 47, Section FCC §2.1046.

3.2. Test Procedure

Output power shall be measured at the RF output terminals for all configurations.

1. The RF output of the transmitter was connected to the input of the mobile test unit in order to establish communication with the EUT.
2. The EUT was set up for the max. output power with pseudo random data modulation by using mobile test unit parameters.
3. This EUT was tested under all configurations and the highest power was investigated and reported.

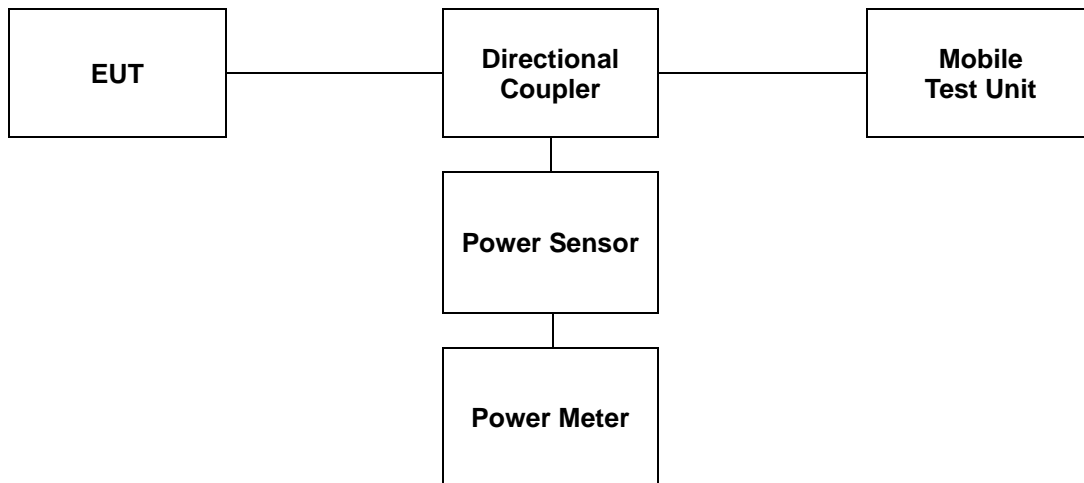

3.3. Test Result

Ambient temperature : (23 ± 1) °C
 Relative humidity : 47 % R.H.

WCDMA V							
Mode	3GPP 34.121 Subtest	Conducted Output Power					
		4132 (826.4 MHz)		4183 (836.6 MHz)		4233 (846.6 MHz)	
		(dB m)	(W)	(dB m)	(W)	(dB m)	(W)
Release 99	12.2 Kbps RMC	23.56	0.227	23.59	0.229	23.65	0.232
HSDPA	Subtest 1	22.50	0.178	22.61	0.182	22.66	0.185
	Subtest 2	22.52	0.179	22.61	0.182	22.63	0.183
	Subtest 3	22.04	0.160	22.12	0.163	22.16	0.164
	Subtest 4	22.02	0.159	22.08	0.161	22.15	0.164
HSUPA	Subtest 1	22.52	0.179	22.59	0.182	21.79	0.151
	Subtest 2	20.47	0.111	20.58	0.114	20.67	0.117
	Subtest 3	21.50	0.141	21.59	0.144	21.54	0.143
	Subtest 4	20.49	0.112	20.59	0.115	20.67	0.117
	Subtest 5	22.52	0.179	22.61	0.182	22.62	0.183
DC-HSPA	Subtest 1	22.12	0.163	22.05	0.160	21.93	0.156
	Subtest 2	22.43	0.175	22.46	0.176	22.31	0.170
	Subtest 3	22.34	0.171	22.29	0.169	22.15	0.164
	Subtest 4	22.51	0.178	22.52	0.179	22.33	0.171
HSPA+		22.49	0.177	22.44	0.175	22.28	0.169

GSM 850							
Mode		Conducted Output Power					
		128 (824.2 MHz)		190 (836.6 MHz)		251 (848.8 MHz)	
		(dB m)	(W)	(dB m)	(W)	(dB m)	(W)
VOICE		32.47	1.766	32.59	1.816	<u>32.95</u>	<u>1.972</u>
GPRS	1 Tx slot	32.43	1.750	32.51	1.782	32.91	1.954
	2 Tx slot	32.21	1.663	32.11	1.626	32.80	1.905
	3 Tx slot	31.85	1.531	31.70	1.479	32.55	1.799
	4 Tx slot	31.55	1.429	31.53	1.422	31.78	1.507
EGPRS	1 Tx slot	32.35	1.718	32.42	1.746	<u>32.85</u>	<u>1.928</u>
	2 Tx slot	32.15	1.641	32.22	1.667	32.62	1.828
	3 Tx slot	31.75	1.496	31.91	1.552	32.47	1.766
	4 Tx slot	31.55	1.429	31.65	1.462	31.71	1.483

GSM 1900							
Mode		Conducted Output Power					
		512 (1 850.2 MHz)		661 (1 880.0 MHz)		810 (1 909.8 MHz)	
		(dB m)	(W)	(dB m)	(W)	(dB m)	(W)
VOICE		<u>29.11</u>	<u>0.815</u>	28.25	0.668	28.33	0.681
GPRS	1 Tx slot	29.10	0.813	28.15	0.653	28.30	0.676
	2 Tx slot	28.95	0.785	28.05	0.638	28.21	0.662
	3 Tx slot	28.89	0.774	28.07	0.641	28.05	0.638
	4 Tx slot	28.83	0.764	28.16	0.655	28.06	0.640
EGPRS	1 Tx slot	<u>29.10</u>	<u>0.813</u>	28.06	0.640	28.55	0.716
	2 Tx slot	29.02	0.798	28.13	0.650	28.41	0.693
	3 Tx slot	28.85	0.767	28.21	0.662	28.36	0.685
	4 Tx slot	28.70	0.741	28.28	0.673	28.25	0.668

4. Occupied Bandwidth

4.1. Limit

CFR 47, Section FCC §2.1049.

4.2. Test Procedure

The test follows section 5.4.4 of ANSI C63.26-2015.

- a. The spectrum analyzer center frequency is set to the nominal EUT channel center frequency. The frequency span for the spectrum analyzer shall be set wide enough to capture all modulation products including the emission skirts (typically a span of $1.5 \times \text{OBW}$ is sufficient).
- b. The nominal IF filter 3 dB bandwidth (RBW) shall be in the range of 1 % to 5 % of the anticipated OBW, and the VBW shall be set $\geq 3 \times \text{RBW}$.
- c. Set the reference level of the instrument as required to prevent the signal amplitude from exceeding the maximum spectrum analyzer input mixer level for linear operation. See guidance provided in 4.2.3.
- d. Set the detection mode to peak, and the trace mode to max-hold.
- e. If the instrument does not have a 99 % OBW function, recover the trace data points and sum directly in linear power terms. Place the recovered amplitude data points, beginning at the lowest frequency, in a running sum until 0.5 % of the total is reached. Record that frequency as the lower OBW frequency. Repeat the process until 99.5 % of the total is reached and record that frequency as the upper OBW frequency. The 99 % power OBW can be determined by computing the difference between these two frequencies.
- f. The OBW shall be reported and plot(s) of the measuring instrument display shall be provided with the test report. The frequency and amplitude axis and scale shall be clearly labeled. Tabular data can be reported in addition to the plot(s).

For the 99 % emission bandwidth, the trace data points are recovered and directly summed in linear power level terms. The recovered amplitude data points, beginning at the lowest frequency, are placed in a running sum until 0.5 % of the total is reached, and that frequency recorded. The process is repeated for the highest frequency data points (starting at the highest frequency, at the right side of the span, and going down in frequency). This frequency is then recorded. The difference between the two recorded frequencies is the occupied bandwidth (or the 99 % emission bandwidth).

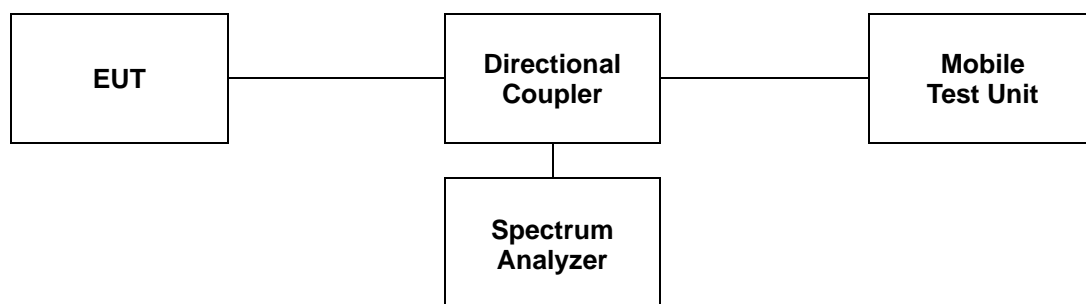

4.3 Test Results

Ambient temperature : (23 ± 1) °C
 Relative humidity : 47 % R.H.

Band	Mode	Frequency (MHz)	Occupied Bandwidth (MHz)
WCDMA V	RMC	836.6	4.156
	HSDPA		4.156

Band	Mode	Frequency (MHz)	Occupied Bandwidth (MHz)
GSM 850	VOICE	836.6	0.232
	EDGE		0.239
GSM 1900	VOICE	1 880.0	0.240
	EDGE		0.242

- Test plots

WCDMA

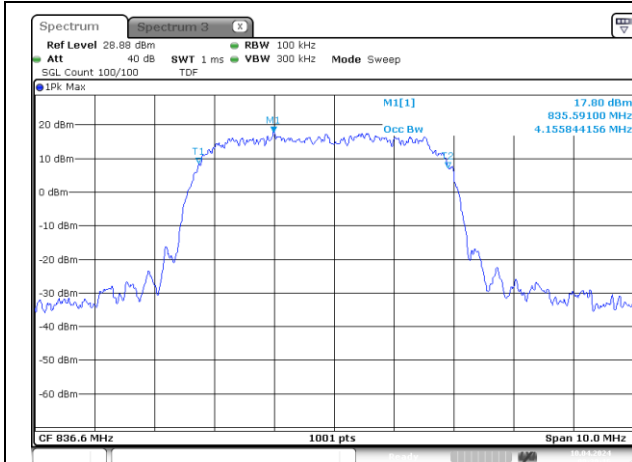

WCDMA V RMC Middle Channel

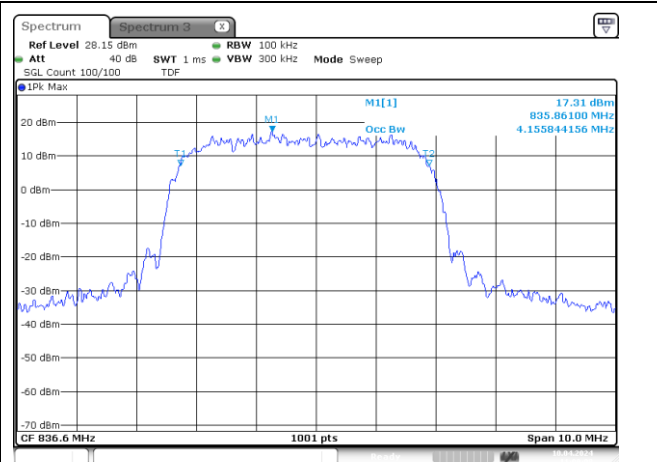

WCDMA V HSDPA Middle Channel

GSM

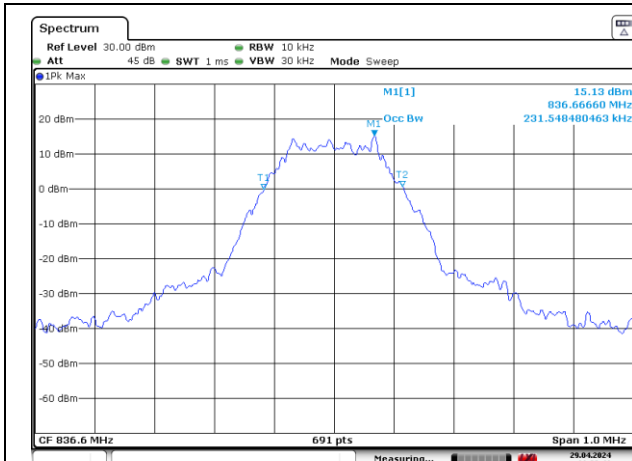

GSM 850 VOICE Middle Channel

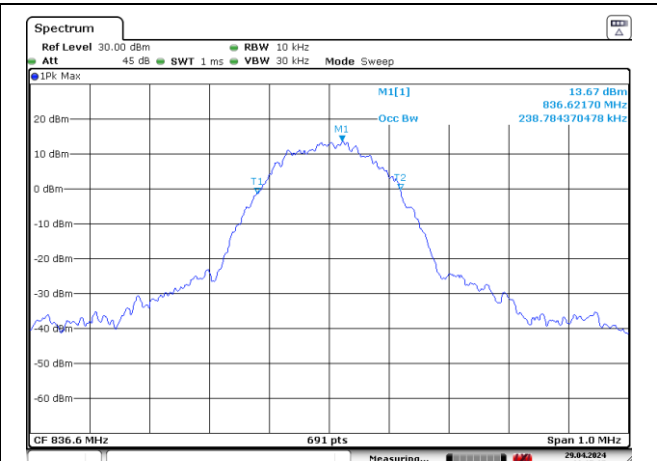

GSM 850 EDGE Middle Channel

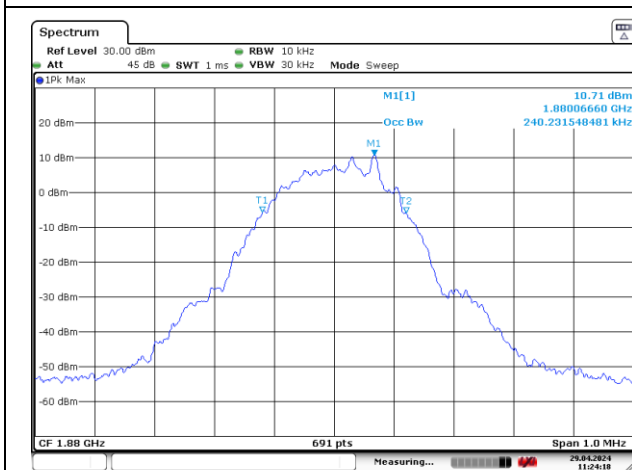

GSM 1900 VOICE Middle Channel

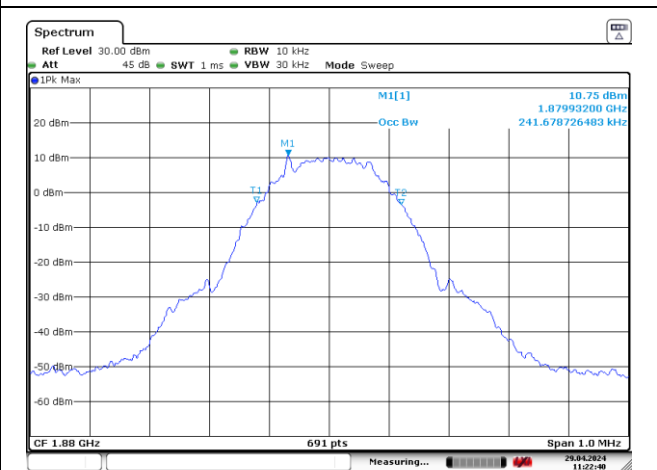

GSM 1900 EDGE Middle Channel

5. Peak-Average Ratio

5.1. Limit

- §22.913(d) Measurement of the ERP of Cellular base transmitters and repeaters must be made using an average power measurement technique. The peak-to-average ratio (PAR) of the transmission must not exceed 13 dB.

- §24.232(d), power measurements for transmissions by stations authorized under this section may be made either in accordance with a Commission-approved average power technique or in compliance with paragraph (e) of this section. In both instances, equipment employed must be authorized in accordance with the provisions of §24.51. In measuring transmissions in this band using an average power technique, the peak-to-average ratio (PAR) of the transmission may not exceed 13 dB.

5.2. Test Procedure

The test follows section 5.2.3.4 of ANSI C63.26-2015.

See instrumentation-specific application literature for further guidance regarding use of the CCDF capability. The following guidelines are offered for performing a CCDF measurement.

- a. Set resolution/measurement bandwidth \geq OBW or specified reference bandwidth.
- b. Set the number of counts to a value that stabilizes the measured CCDF curve.
- c. Set the measurement interval as follows:
 - 1) For continuous transmissions, set to greater of $[10 \times (\text{number of points in sweep}) \times (\text{transmission symbol period})]$ or 1 ms.
 - 2) For burst transmissions, employ an external trigger that is synchronized with the EUT burst timing sequence, or use the internal burst trigger with a trigger level that allows the burst to stabilize. Set the measurement interval to a time that is less than or equal to the burst duration.
 - 3) If there are several carriers in a single antenna port, the peak power shall be determined for each individual carrier (by disabling the other carriers while measuring the required carrier) and the total peak power calculated from the sum of the individual carrier peak powers.
- d. Record the maximum PAPR level associated with a probability of 0.1 %.
- e. The peak power level is calculated from the sum of the PAPR value from step d) to the measured average power.

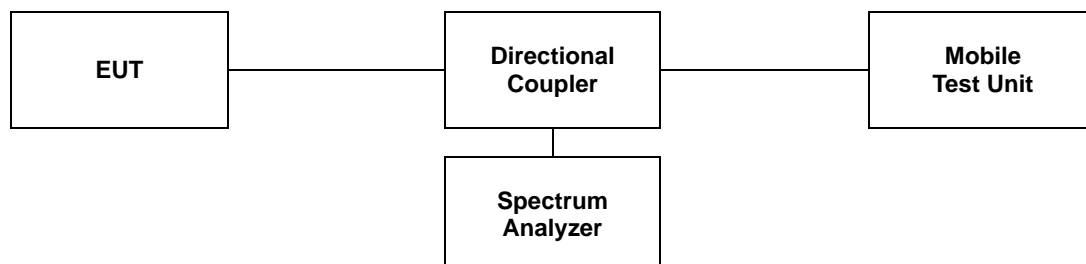

5.3 Test Results

Ambient temperature : (23 ± 1) °C
 Relative humidity : 47 % R.H.

Band	Mode	Frequency (MHz)	PAR (dB)
WCDMA V	RMC	826.4	2.58
		836.6	3.13
		846.6	2.87
	HSDPA	826.4	2.96
		836.6	3.57
		846.6	3.07

Band	Mode	Frequency (MHz)	PAR (dB)
GSM 850	VOICE	824.2	3.04
		836.6	3.10
		848.8	3.13
	EDGE	824.2	3.01
		836.6	3.16
		848.8	3.13
GSM 1900	VOICE	1 850.2	4.03
		1 880.0	3.83
		1 909.8	3.68
	EDGE	1 850.2	4.03
		1 880.0	3.83
		1 909.8	3.71

- Test plots

WCDMA V

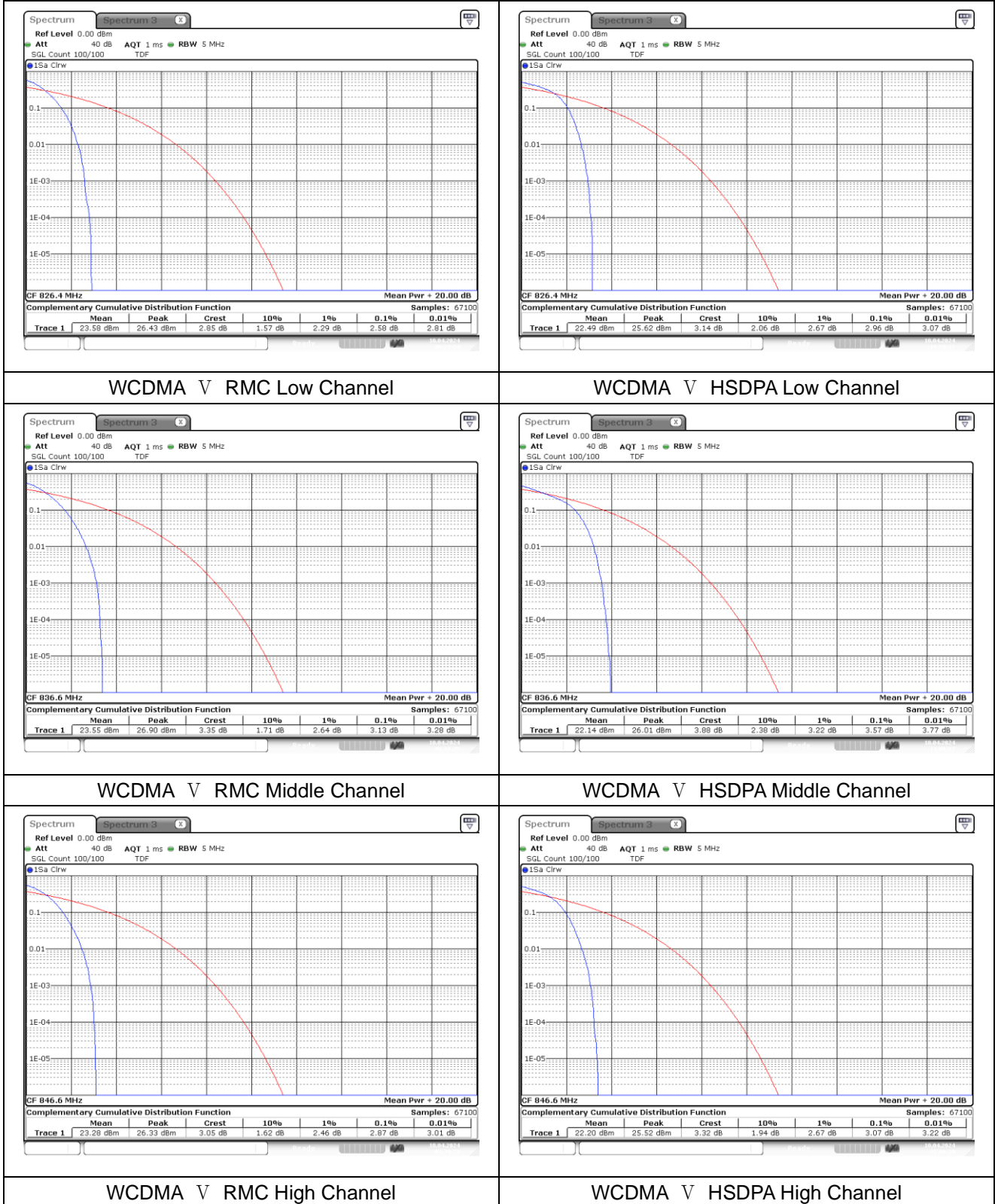

GSM 850

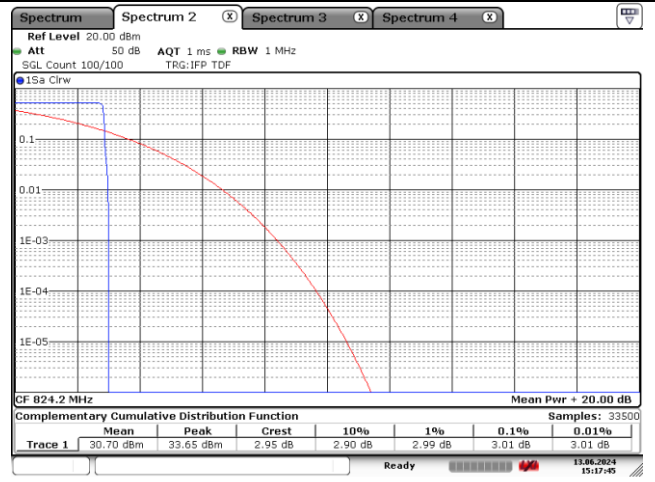
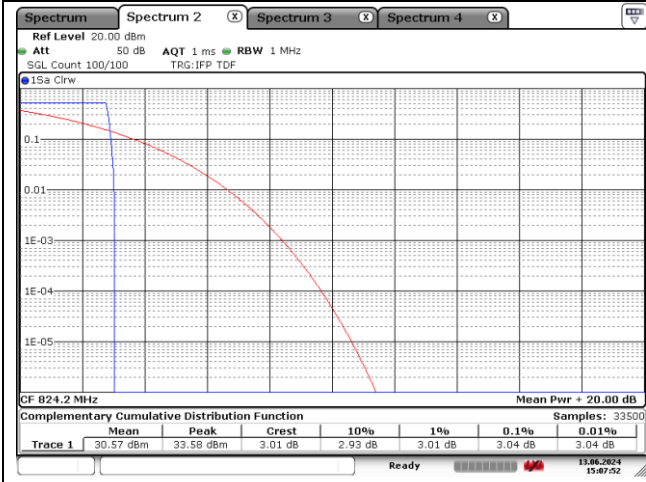

GSM 850 VOICE Low Channel

GSM 850 EDGE Low Channel

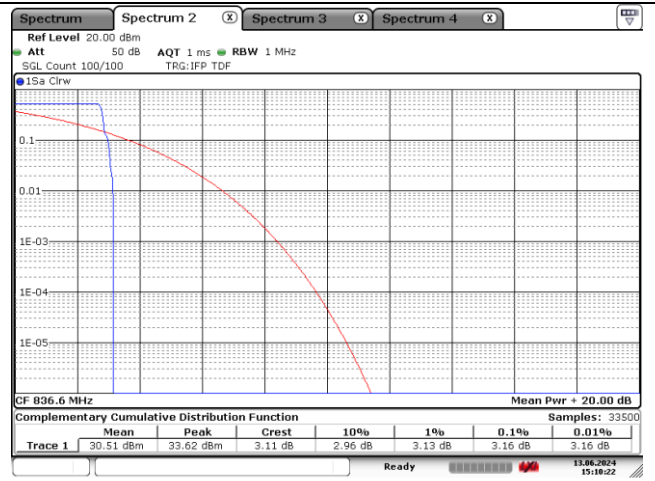
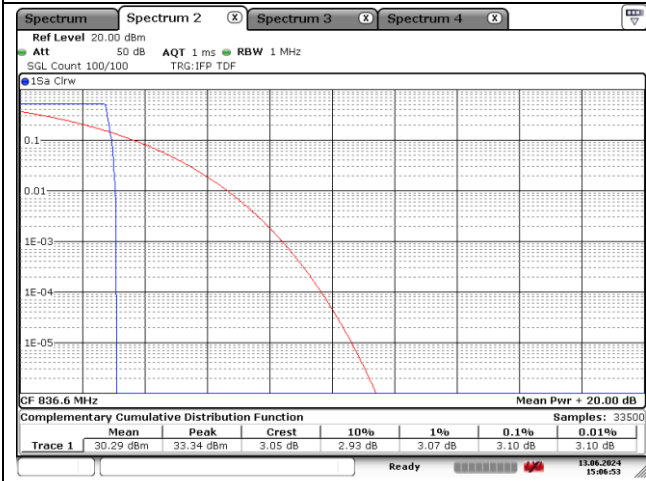

GSM 850 VOICE Middle Channel

GSM 850 EDGE Middle Channel

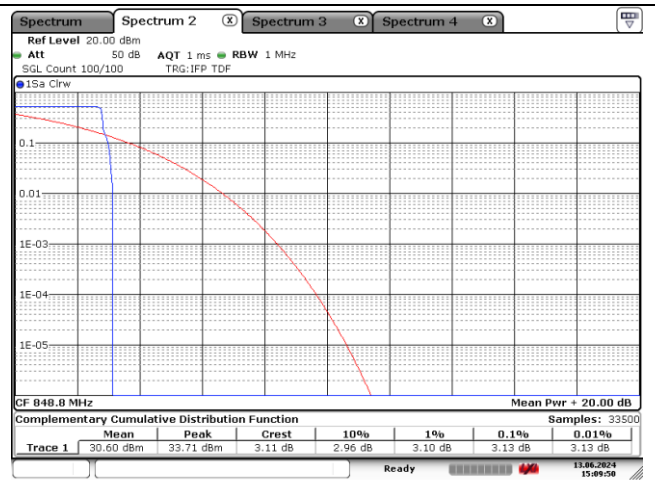
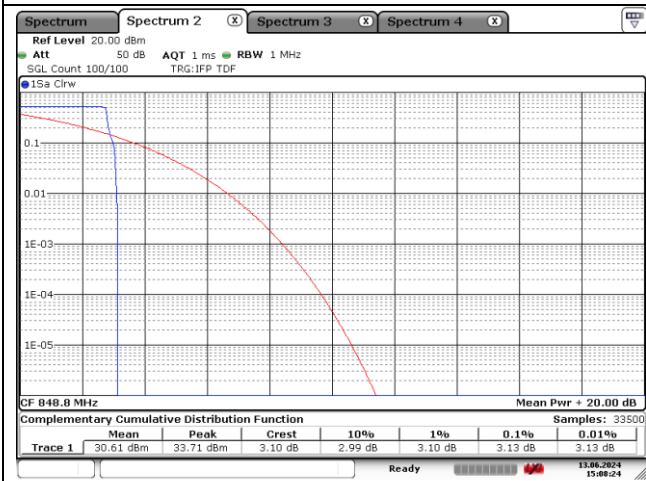

GSM 850 VOICE High Channel

GSM 850 EDGE High Channel

GSM 1900

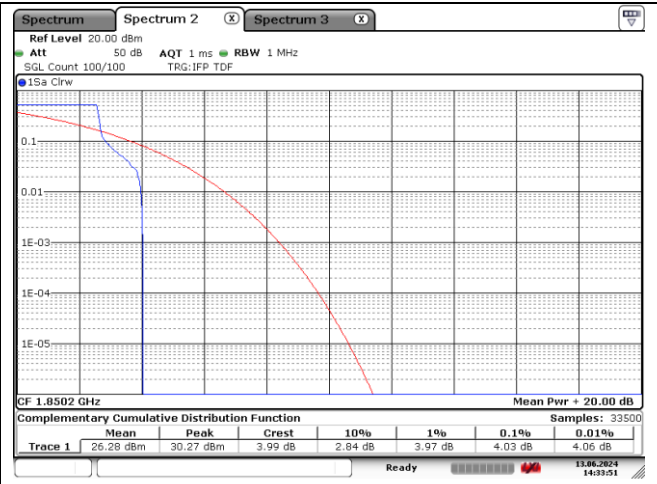
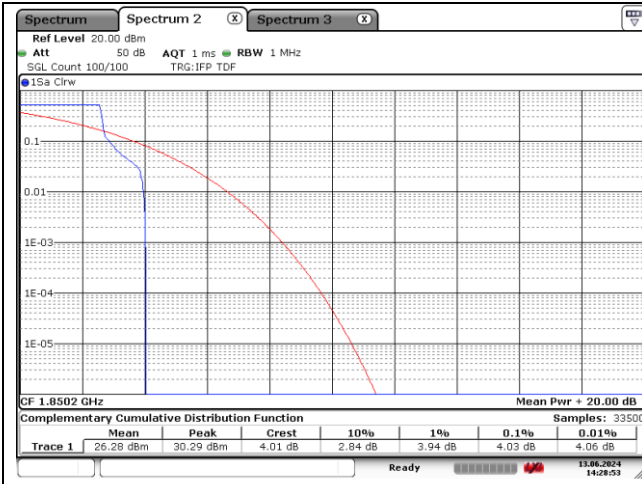

GSM 1900 VOICE Low Channel

GSM 1900 EDGE Low Channel

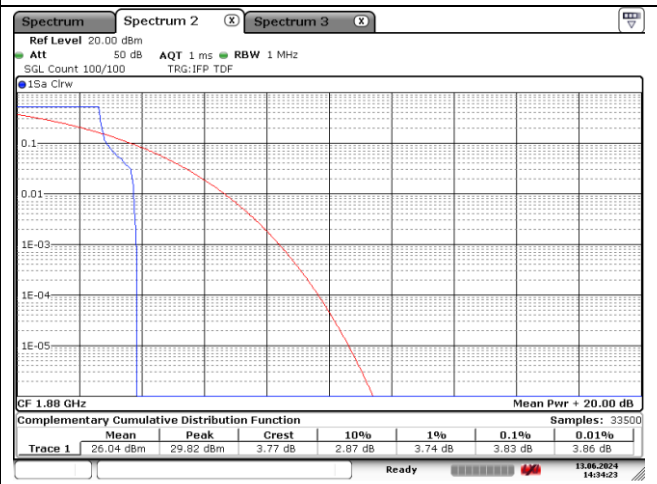
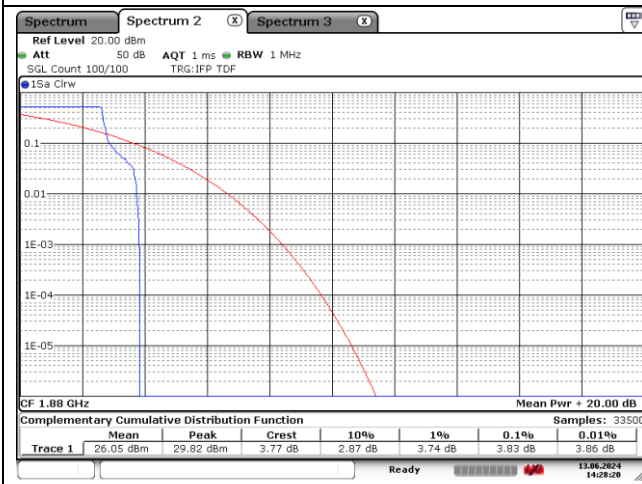

GSM 1900 VOICE Middle Channel

GSM 1900 EDGE Middle Channel

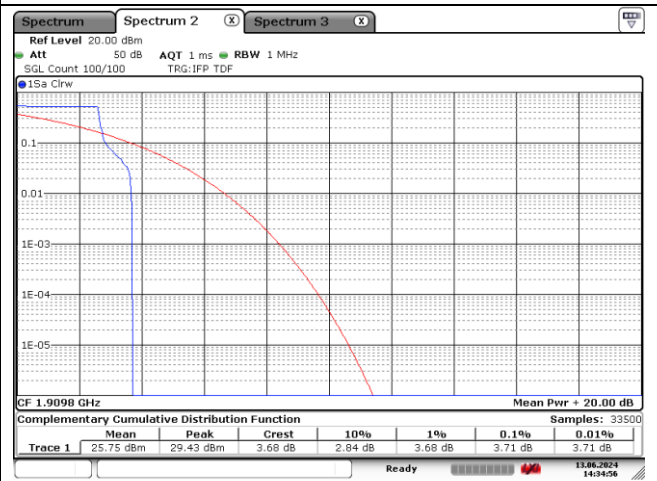
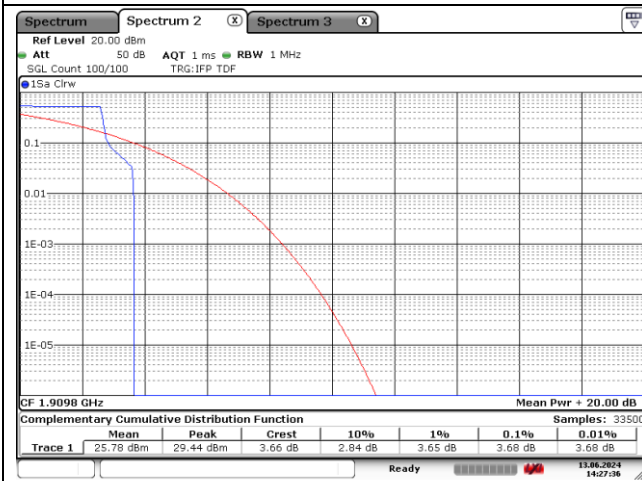

GSM 1900 VOICE High Channel

GSM 1900 EDGE High Channel

6. Spurious Emissions at Antenna Terminal

6.1. Limit

- §22.917(a), the power of any emission outside of the authorized operating frequency ranges must be attenuated below the transmitting power (P) by a factor of at least $43 + 10\log(P)$ dB.

- §24.238(a), the power of any emission outside of the authorized operating frequency ranges must be attenuated below the transmitting power (P) by a factor of at least $43 + 10 \log(P)$ dB.

6.2. Test Procedure

The test follows section 5.7 of ANSI C63.26-2015.

1. Start frequency was set to 9 kHz and stop frequency was set to at least 10* the fundamental frequency.
2. Detector = RMS.
3. Trace mode = Max hold.
4. Sweep time = Auto couple.
5. The trace was allowed to stabilize.
6. Please see notes below for RBW and VBW settings.
7. For plots showing conducted spurious emissions from 9 kHz to 20 GHz, all path loss of wide frequency range was investigated and compensated to spectrum analyzer as TDF function.

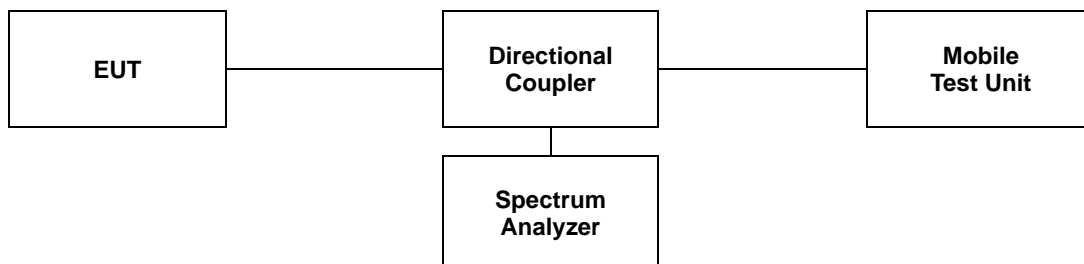

Note;

Compliance with the applicable limits is based on the use of measurement instrumentation employing a resolution bandwidth of 100 kHz or greater for frequencies less than 1 GHz and frequencies greater than 1 GHz. However, in the 1 MHz bands immediately outside and adjacent to the frequency block a resolution bandwidth of at least one percent of the emission bandwidth of the fundamental emission of the transmitter may be employed. The emission bandwidth is defined as the width of the signal between two point, one below the carrier center frequency and one above the carrier center frequency, outside of which all emission are attenuated at least 26 dB below the transmitter power.

6.3. Test Results

Ambient temperature : (23 ± 1) °C
 Relative humidity : 47 % R.H.

- Test plots

WCDMA ▾

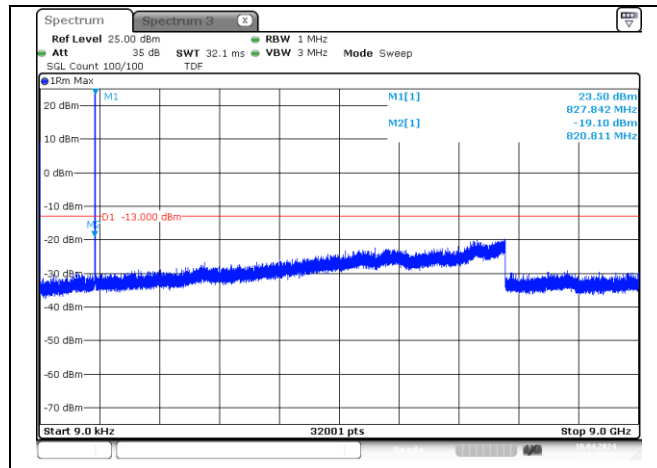

WCDMA ▾ RMC Low channel

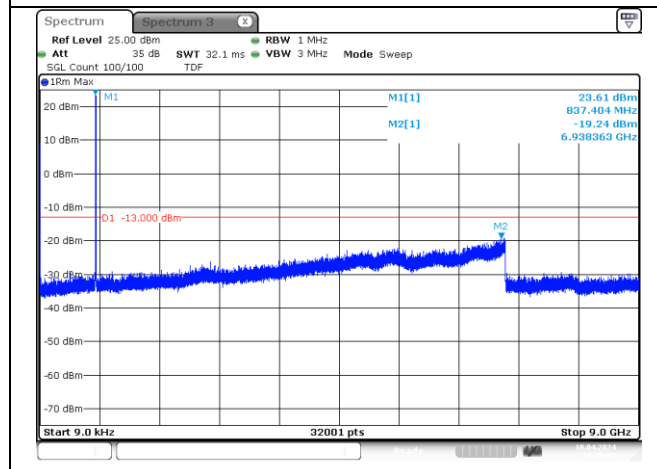

WCDMA ▾ RMC Middle channel

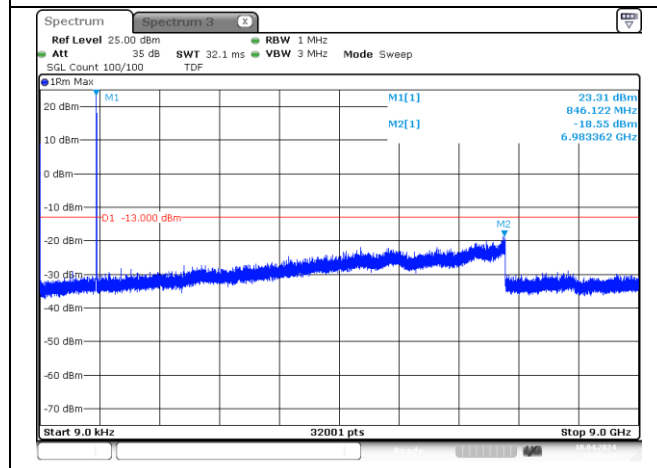

WCDMA ▾ RMC High channel

GSM 850

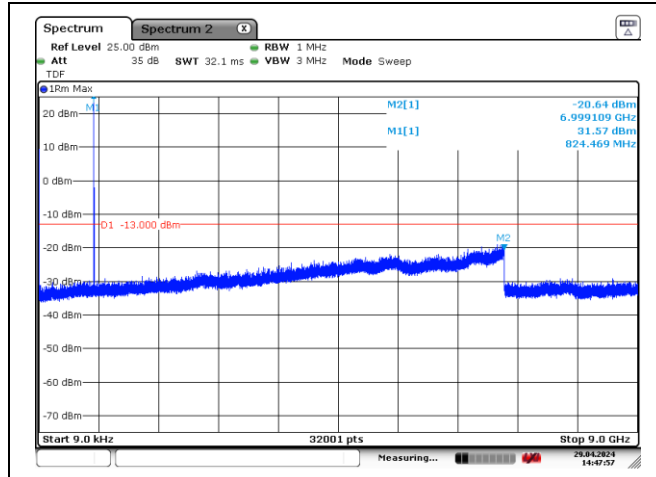

GSM 850 VOICE Low Channel

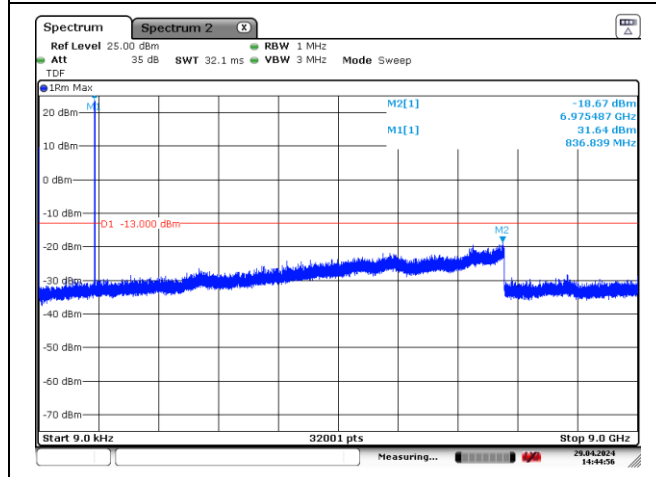

GSM 850 VOICE Middle Channel

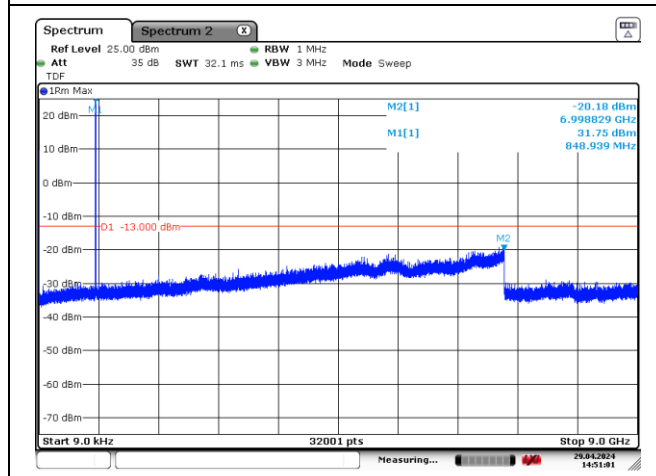

GSM 850 VOICE High Channel

GSM 1900

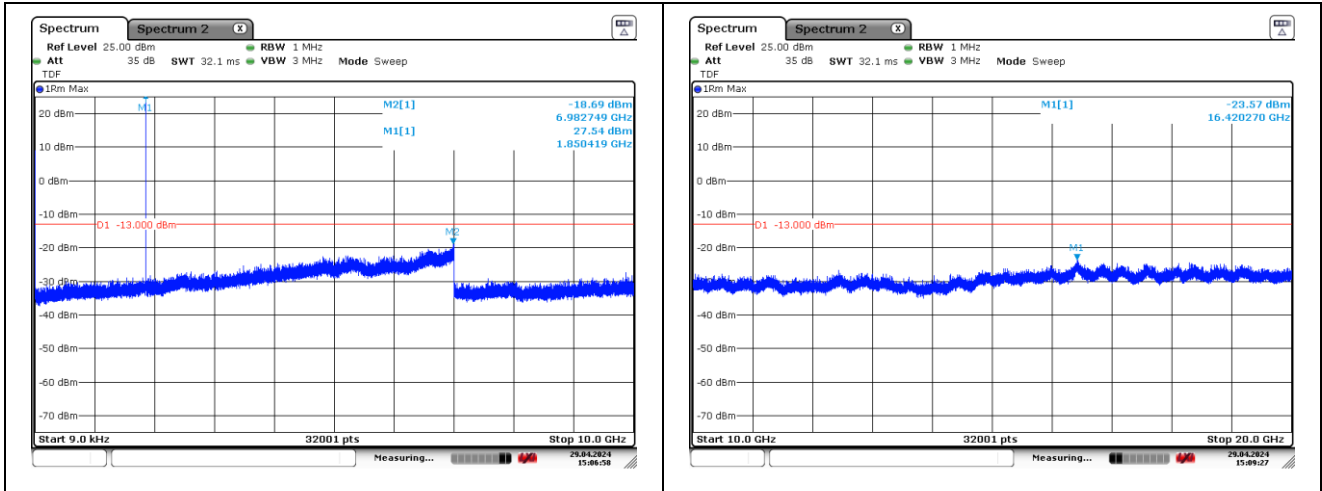

GSM 1900 VOICE Low Channel

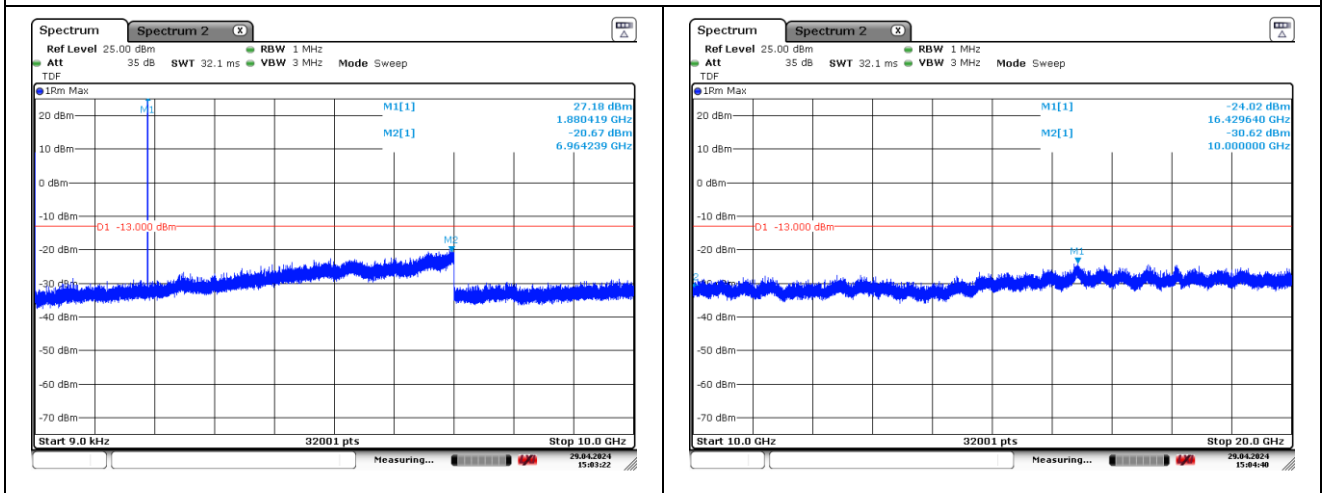

GSM 1900 VOICE Middle Channel

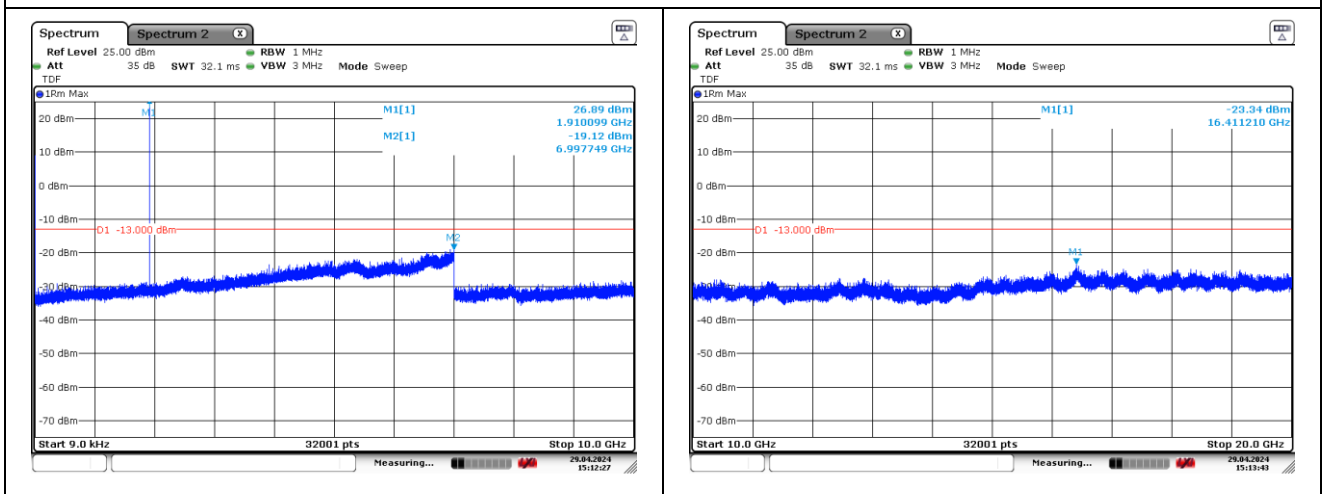

GSM 1900 VOICE High Channel

7. Band Edge

7.1. Limit

- §22.917(a), the power of any emission outside of the authorized operating frequency ranges must be attenuated below the transmitting power (P) by a factor of at least $43 + 10\log(P)$ dB.
- §24.238(a), the power of any emission outside of the authorized operating frequency ranges must be attenuated below the transmitting power (P) by a factor of at least $43 + 10 \log(P)$ dB.

7.2. Test Procedure

The test follows section 5.7 of ANSI C63.26-2015.

- a. Span was set large enough so as to capture all out of band emissions near the band edge.
- b. RBW ≥ 1 % of OBW
- c. VBW $\geq 3 \times$ RBW.
- d. Detector = RMS.
- e. Trace mode = Average.
- f. Sweep time = Auto.
- g. The trace was allowed to stabilize.
- h. All path loss of frequency range was investigated and compensated to spectrum analyzer as TDF function.

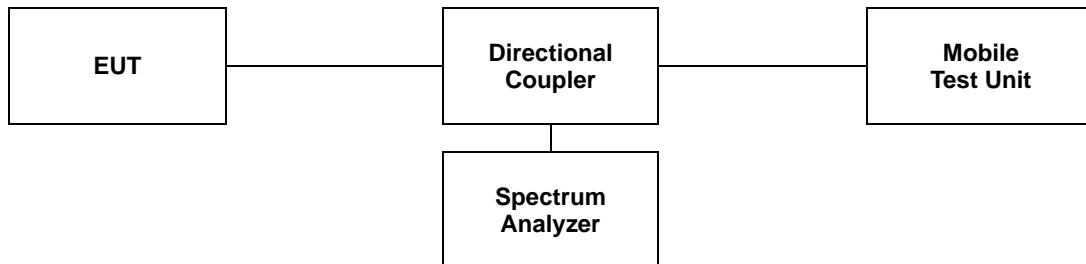

7.3. Test Results

Ambient temperature : (23 ± 1) °C
 Relative humidity : 47 % R.H.

- Test plots

WCDMA V

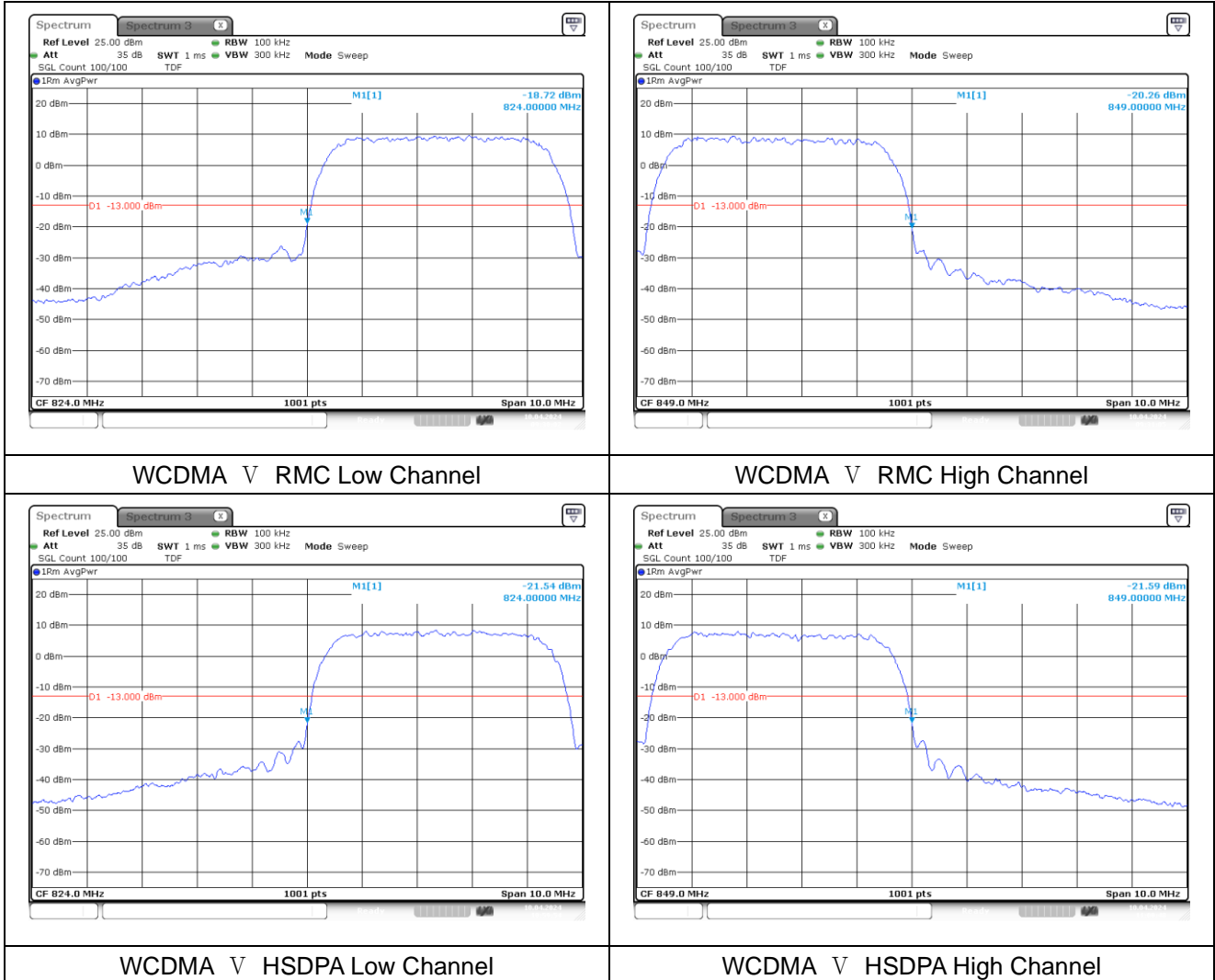

GSM 850

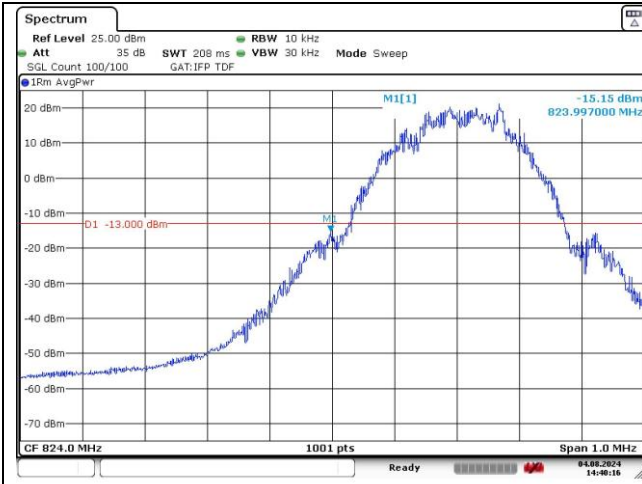

GSM 850 VOICE Low Channel

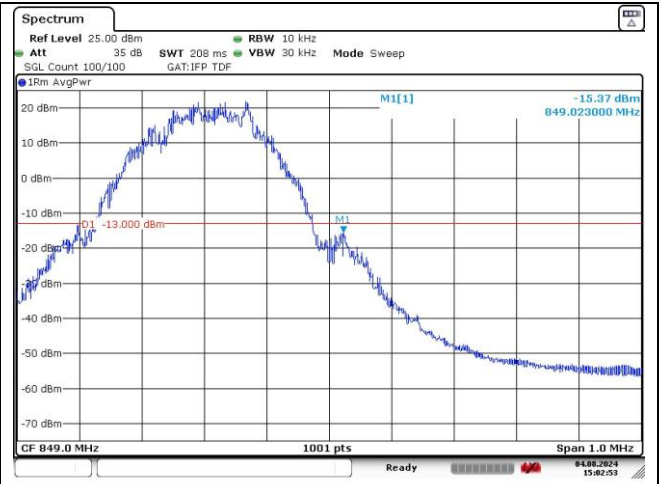

GSM 850 VOICE High Channel

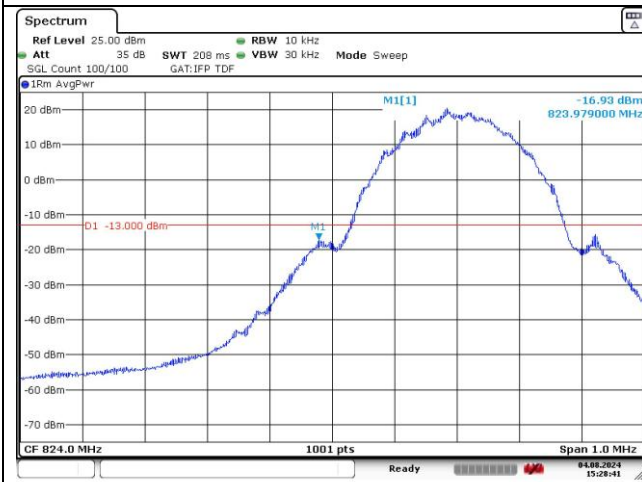

GSM 850 EDGE Low Channel

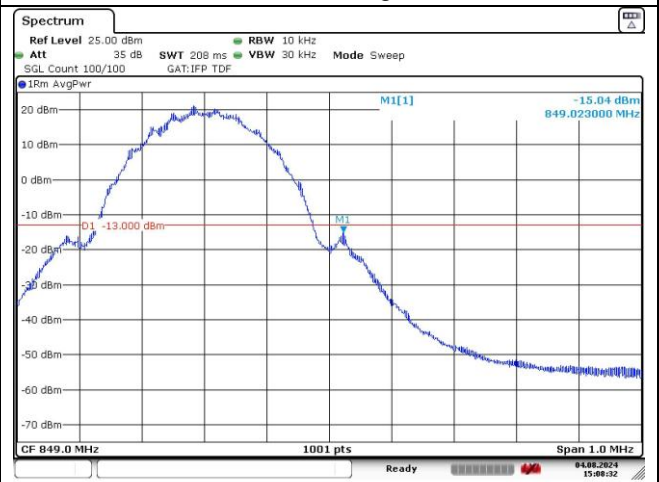

GSM 850 EDGE High Channel

GSM 1900

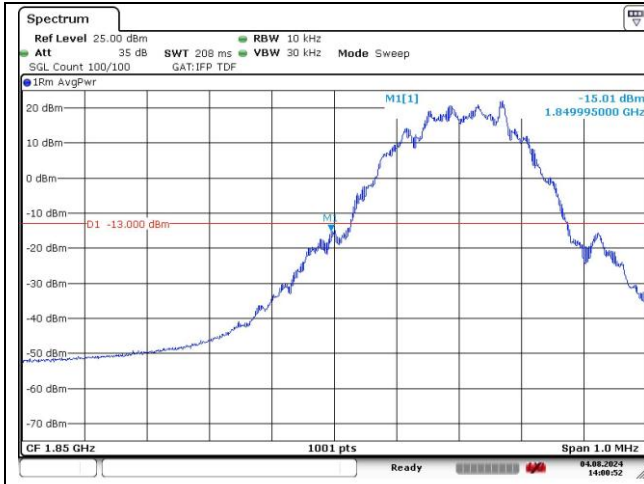

GSM 1900 VOICE Low Channel

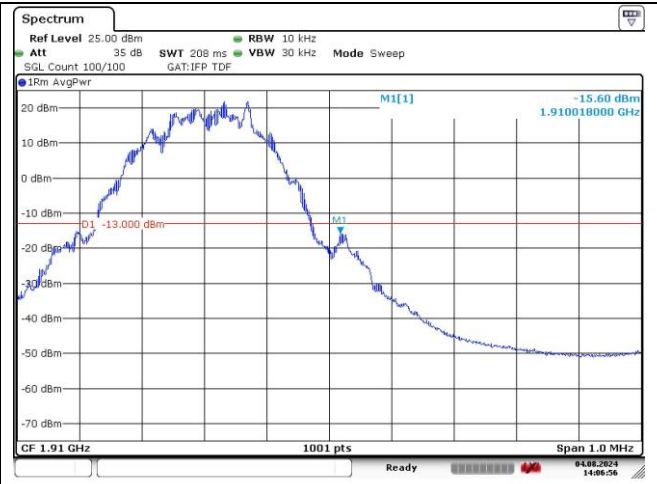

GSM 1900 VOICE High Channel

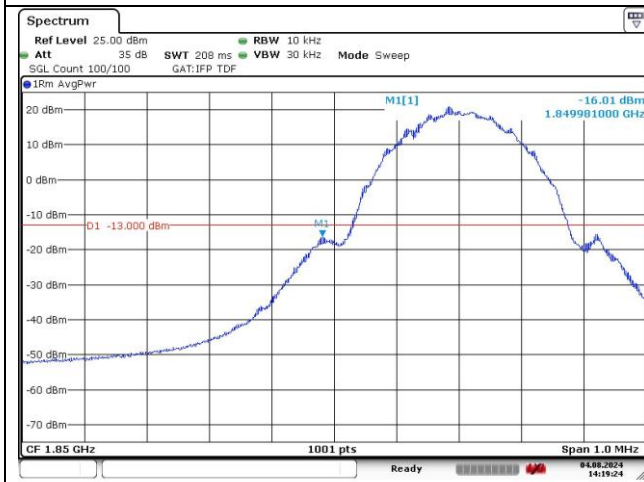

GSM 1900 EDGE Low Channel

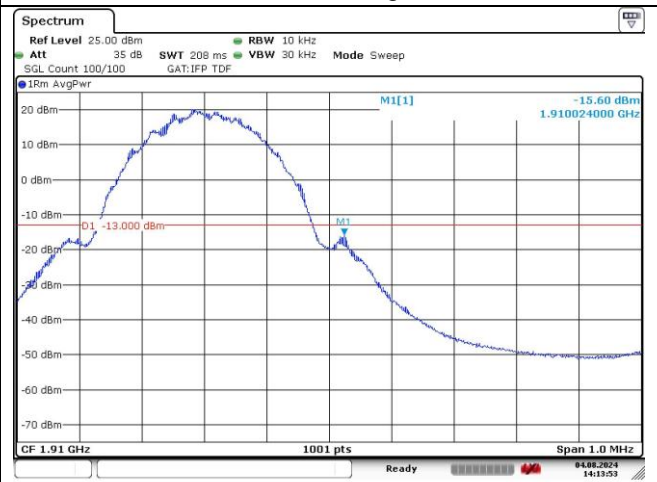

GSM 1900 EDGE High Channel

8. Frequency Stability

8.1. Limit

- § 2.1055 (a), § 2.1055 (d) & following:

- §22.355, the carrier frequency of each transmitter in the Public Mobile Services must be maintained within the tolerances given in Table of this section.

For Mobile devices operating in the 824 to 849 MHz band at a power level less than or equal to 3 Watts, the limit specified in Table C-1 is +/- 2.5 ppm.

- §24.235, the frequency stability shall be sufficient to ensure that the fundamental emission stays within the authorized frequency block.

8.2. Test Procedure

1. Frequency Stability vs. Temperature: The equipment under test was connected to an external DC power supply and the RF output was connected to a Mobile Test Unit via feed-through attenuators.
2. The EUT was placed inside the temperature chamber.
3. After the temperature stabilized for approximately 20 minutes, the frequency output was recorded from Mobile Test Unit.

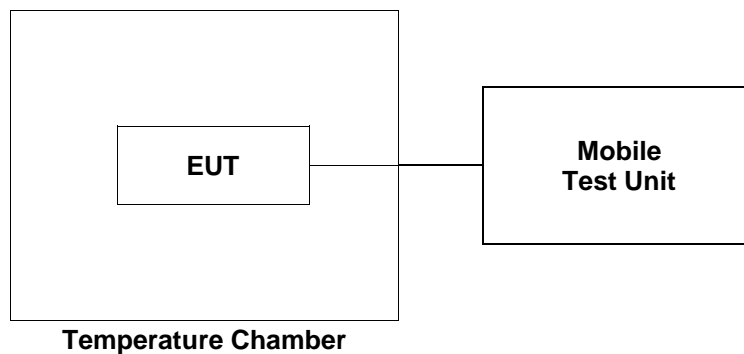

8.3. Test Results

Ambient temperature : (23 ± 1) °C
 Relative humidity : 47 % R.H.

WCDMA V mode at middle channel

Reference Frequency: 836.6 MHz			
Frequency Stability versus Temperature			
Environment Temperature (°C)	Power Supplied (V)	Frequency Measure with Time Elapse	
		Frequency Error (Hz)	ppm
50	4.00	12.23	-0.004 04
40		13.24	-0.002 83
30		15.27	-0.000 41
20(Ref.)		15.61	-
10		11.79	-0.004 57
0		14.93	-0.000 81
-10		15.39	-0.000 26
-20		14.08	-0.001 83
-30		14.87	-0.000 88
Frequency Stability versus Power Supply			
Environment Temperature (°C)	Power Supplied (V)	Frequency Measure with Time Elapse	
		Frequency Error (Hz)	ppm
20	3.40 (85%)	11.40	-0.005 03
	4.60 (115%)	14.40	-0.001 45

GSM 850 mode at middle channel

Reference Frequency: 836.6 MHz			
Frequency Stability versus Temperature			
Environment Temperature (°C)	Power Supplied (V)	Frequency Measure with Time Elapse	
		Frequency Error (Hz)	ppm
50	4.00	11.38	-0.005 04
40		12.01	-0.004 29
30		11.28	-0.005 16
20(Ref.)		15.60	-
10		14.82	-0.000 93
0		11.71	-0.004 65
-10		13.02	-0.003 08
-20		13.93	-0.002 00
-30		11.83	-0.004 51
Frequency Stability versus Power Supply			
Environment Temperature (°C)	Power Supplied (V)	Frequency Measure with Time Elapse	
		Frequency Error (Hz)	ppm
20	3.40 (85%)	15.83	0.000 27
	4.60 (115%)	14.93	-0.000 80

GSM 1900 mode at middle channel

Reference Frequency: 1 880.0 MHz			
Frequency Stability versus Temperature			
Environment Temperature (°C)	Power Supplied (V)	Frequency Measure with Time Elapse	
		Frequency Error (Hz)	ppm
50	4.00	34.84	0.001 80
40		35.33	0.002 06
30		34.82	0.001 79
20(Ref.)		31.46	-
10		35.45	0.002 12
0		34.95	0.001 86
-10		34.56	0.001 65
-20		33.05	0.000 85
-30		35.69	0.002 25
Frequency Stability versus Power Supply			
Environment Temperature (°C)	Power Supplied (V)	Frequency Measure with Time Elapse	
		Frequency Error (Hz)	ppm
20	3.40 (85%)	35.52	0.002 16
	4.60 (115%)	32.26	0.000 43

- End of the Test Report -