

TEST REPORT

of

FCC Part 2 Subpart J, Part 22 Subpart C/H,
Part 24 Subpart E, Part 27 Subpart C and Part 90 Subpart S

FCC ID: YZP-GN3000

Equipment Under Test : Telematics Module
Model Name : LTD-GN3000
Variant Model Name(s) : -
Applicant : LG Innotek Co., Ltd.
Manufacturer : LG Innotek Co., Ltd.
Date of Receipt : 2024.02.15
Date of Test(s) : 2024.02.16 ~ 2024.08.28
Date of Issue : 2024.08.28

In the configuration tested, the EUT complied with the standards specified above. This test report does not assure KOLAS accreditation.

- 1) The results of this test report are effective only to the items tested.
- 2) The SGS Korea is not responsible for the sampling, the results of this test report apply to the sample as received.
- 3) This test report cannot be reproduced, except in full, without prior written permission of the Company.
- 4) The data marked ※ in this report was provided by the customer and may affect the validity of the test results.

We are responsible for all the information of this test report except for the data(※) provided by the customer.

Tested by:



Dave Kim

Technical
Manager:



Patrick Kang

SGS Korea Co., Ltd. Gunpo Laboratory

INDEX

<u>Table of Contents</u>	Page
1. General Information	3
2. E.R.P. / E.I.R.P. & Radiated Spurious Emissions	18
3. Conducted Output Power	38
4. Occupied Bandwidth	61
5. Peak-Average Ratio	79
6. Spurious Emissions at Antenna Terminal	91
7. Band Edge and Emission Mask	99
8. Frequency Stability	141

1. General Information

1.1. Testing Laboratory

SGS Korea Co., Ltd. (Gunpo Laboratory)
 - 10-2, LS-ro 182beon-gil, Gunpo-si, Gyeonggi-do, Korea, 15807
 - 4, LS-ro 182beon-gil, Gunpo-si, Gyeonggi-do, Korea, 15807
 - Designation number: KR0150

All SGS services are rendered in accordance with the applicable SGS conditions of service available on request and accessible at <http://www.sgs.com/en/Terms-and-Conditions.aspx>.

Phone No. : +82 31 688 0901
 Fax No. : +82 31 688 0921

1.2. Details of Applicant

Applicant : LG Innotek Co., Ltd.
 Address : 30 Magokjungang 10-ro, Gangseo-gu, seoul, Republic Of Korea, 07996
 Contact Person : Jeong, In-chang
 Phone No. : +82 10 2326 9972

1.3. Details of Manufacturer

Company : Same as applicant
 Address : Same as applicant
 Factory1 : PT. LG INNOTEK INDONESIA
 Factory1 Adress : Bekasi International Industrial Estate, Blok C8 No. 12 & 12A, Desa Cibatu, Cikarang Selatan, Bekasi 17750, Jawa Barat - Indonesia
 Factory2 : LG Innotek Co., Ltd.
 Factory2 Adress : 26, Hanamsandan 5beon-ro, Gwangsan-gu, Gwangju, Republic of Korea, 62229

1.4. Description of EUT

Kind of Product	Telematics Module
Model Name	LTD-GN3000
Serial Number	Conducted: C1 Radiated: R1
Power Supply	DC 4.00 V
Rated Power	LTE Band 2, 4, 5, 7, 25, 26, 38, 41, 66 : 23 dB m
Frequency Range	LTE Band 2: 1 850 MHz ~ 1 910 MHz LTE Band 4: 1 710 MHz ~ 1 755 MHz LTE Band 5: 824 MHz ~ 849 MHz LTE Band 7: 2 500 MHz ~ 2 570 MHz LTE Band 25: 1 850 MHz ~ 1 915 MHz LTE Band 26: 814 MHz ~ 849 MHz LTE Band 38: 2 570 MHz ~ 2 620 MHz LTE Band 41: 2 496 MHz ~ 2 690 MHz LTE Band 66: 1 710 MHz ~ 1 780 MHz
Uplink CA Bands	5B, 7C, 38C, 41C, 66B, 66C 2A-5A, 4A-5A, 5A-7A, 5A-25A, 5A-66A, 25A-26A
Modulation Technique	QPSK, 16QAM, 64QAM, 256QAM
Antenna Type	Dipole Antenna
Antenna Gain	Refer to the clause 1.17
H/W Version	A.4
S/W Version	01L_TCM

1.5. Test Equipment List

Equipment	Manufacturer	Model	S/N	Cal. Date	Cal. Interval	Cal. Due
Spectrum Analyzer	R&S	FSV30	100955	Mar. 08, 2024	Annual	Mar. 08, 2025
Spectrum Analyzer	R&S	FSW43	100637	Apr. 08, 2024	Annual	Apr. 08, 2025
Spectrum Analyzer	Agilent	N9030A	US51350132	Nov. 27, 2023	Annual	Nov. 27, 2024
Signal Generator	R&S	SMA100B	106887	Oct. 06, 2023	Annual	Oct. 06, 2024
DC Power Supply	R&S	HMP2020	102133	Apr. 23, 2024	Annual	Apr. 23, 2025
Communication test station	Anritsu	MT8000A	6261867312	Apr. 08, 2024	Annual	Apr. 08, 2025
Communication Analyzer	Anritsu	MT8821C	6262192291	Feb. 08, 2024	Annual	Feb. 08, 2025
Temperature Chamber	ESPEC CORP.	PL-2J	15004184	Jun. 03, 2024	Annual	Jun. 03, 2025
BRIDGE COUPLER	MARKI MICROWAVE INC	CBR16-0012	1542	May 13, 2024	Annual	May 13, 2025
Directional Coupler	KRYTAR	152613	140973	Jun. 07, 2024	Annual	Jun. 07, 2025
Power Sensor	Anritsu	MA2411B	1207272	May 29, 2024	Annual	May 29, 2025
Power Sensor	Anritsu	ML2495A	1223004	May 29, 2024	Annual	May 29, 2025
Low Pass Filter	Mini-Circuits	NLP-1200+	V 8979400903-1	May 17, 2024	Annual	May 17, 2025
High Pass Filter	Wainwright Instrument GmbH	WHKX10-900-1000-18000-40SS	7	Feb. 27, 2024	Annual	Feb. 27, 2025
High Pass Filter	Wainwright Instrument GmbH	WHKX3.0/18G-6SS	21	Jun. 07, 2024	Annual	Jun. 07, 2025
High Pass Filter	Wainwright Instrument GmbH	WHNX7.5/26.5G-6SS	11	Oct. 17, 2023	Annual	Oct. 17, 2024
Preamplifier	H.P.	8447F	2944A03909	Aug. 04, 2023	Annual	Aug. 09, 2025
Preamplifier	R&S	SCU 18F	101058	Dec. 07, 2023	Annual	Dec. 07, 2024
Preamplifier	MITEQ Inc.	JS44-18004000-35-8P	1546891	Oct. 06, 2023	Annual	Oct. 06, 2024
Test Receiver	R&S	ESU26	100109	Jan. 16, 2024	Annual	Jan. 16, 2025
Loop Antenna	Schwarzbeck Mess-Elektronik	FMZB 1519	1519-039	Aug. 21, 2023	Biennial	Aug. 21, 2025
Bilog Antenna	Schwarzbeck Mess-Elektronik	VULB9163	9163-437	May 29, 2024	Annual	May 29, 2025
Horn Antenna	R&S	HF906	100326	Feb. 19, 2024	Annual	Feb. 19, 2025
Horn Antenna	Schwarzbeck Mess-Elektronik	BBHA 9170	9170-540	Dec. 05, 2023	Annual	Dec. 05, 2024
Antenna Master	Innco systems GmbH	MA4640-XP-ET	MA4640/536/383 30516/L	N.C.R.	N/A	N.C.R.
Turn Table	Innco systems GmbH	DS 1200S	N/A	N.C.R.	N/A	N.C.R.
Controller	Innco systems GmbH	CONTROLLER CO3000-4P	CO3000/963/383 30516/L	N.C.R.	N/A	N.C.R.
Anechoic Chamber	SY Corporation	L x W x H (9.6 m x 6.4 m x 6.6 m)	N/A	N.C.R.	N/A	N.C.R.
Coaxial Cable	RADIALL	TESTPRO 3	182287	Apr. 12, 2024	Semi-Annual	Oct. 12, 2024
Coaxial Cable	RADIALL	TESTPRO 3	182288	Apr. 12, 2024	Semi-Annual	Oct. 12, 2024
Coaxial Cable	RADIALL	TESTPRO 3	182291	Apr. 12, 2024	Semi-Annual	Oct. 12, 2024
Coaxial Cable	SENSORVIEW	NMST-13A26-NMST-5 m	TPC2402190004	Apr. 03, 2024	Semi-Annual	Oct. 03, 2024
Coaxial Cable	SENSORVIEW	NMST-13A26-NMST-10 m	TPC2402190001	Apr. 03, 2024	Semi-Annual	Oct. 03, 2024

Note;

- For equipment listed above that has a calibration date or calibration due date that falls within the test date range, care was taken to ensure that this equipment was used after the calibration date and before the calibration due date.
- Equipment after the calibration due date was not used for testing.

1.6. Summary of Test Results

The EUT has been tested according to the following specifications:

APPLIED STANDARD: FCC Part 2, 22, 24, 27 and 90		
Section	Test Item(s)	Result
§22.913(a)(5) §24.232(c) §27.50(d)(4) §27.50(h)(2) §90.635(b)	E.R.P. / E.I.R.P.	Complied ¹⁾
§22.917(a) §24.238(a) §27.53(h)(1) §27.53(m)(4) §90.691(a)	Spurious Radiated Emission	Complied
§2.1046	Conducted Output Power	Complied ¹⁾
§2.1049	Occupied Bandwidth	Complied ¹⁾
§22.913(d) §24.232(d) §27.50(d)(5)	Peak-Average Ratio	Complied ¹⁾
§22.917(a) §24.238(a) §27.53(h)(1) §27.53(m)(4) §90.691(a)	Spurious Emission at Antenna Terminal	Complied ¹⁾
§22.917(a) §24.238(a) §27.53(h)(1) §27.53(m)(4) §90.691(a)	Band Edge and Emission Mask	Complied ¹⁾
§2.1055 §22.355 §24.235 §27.54 §90.213(a)	Frequency Stability	Complied ¹⁾

Note;

1) The test items of inter band CA were covered by LTE single carrier due to the CA power is reduced according to 3GPP MPR

1.7. Sample Calculation for Offset

Where relevant, the following sample calculation is provided:

1.7.1. Conducted Test

Offset value (dB) = Directional Coupler (dB) + Cable loss (dB)

1.7.2. Radiation test

- E.I.R.P. (dB m) = Measured level (dB μ V) + Antenna factor (dB/m) + Cable loss (dB) + 20 Log D - 104.8;
 where D is the measurement distance in meters.
- E.R.P. (dB m) = E.I.R.P. (dB m) - 2.15 (dB)

1.8. Worst Case Configuration and Mode

The worst-case is based on the conducted output power measurement investigation results. All testing was performed using QPSK and 16QAM modulations. However, the spurious radiated emission and spurious at antenna terminal were only performed on bandwidth and RB offset (with RB size 1) with the highest conducted power in QPSK.

The peak to average ratio were tested only 256QAM modulation as worst case.

The radiation test of the EUT was investigated in three orthogonal orientations X, Y, and Z, and the worst case data is reported.

1.9. Introduction of Test Data Reuse

This report referenced from the FCC ID: YZP-GN1000.

The applicant takes full responsibility that the test data as referenced in this report represent compliance for this FCC ID.

1.10. Difference

Model name	Description
LTD-GN1000	- Reference model - Single modular
LTD-GN3000	- The PCB and component placement are the same, but the filter has been changed.

1.11. Reference Detail

Reference applicant that contains the reused reference data in the individual test reports:

Equipment class	Reference FCC ID	Application type	Reference test report number	Exhibit type	Variant test report number	Data reuse
PCB	YZP-GN1000	Original grant	F690501-RF-RTL005195 (LTE)	Test report	F690501-RF-RTL005288 (LTE)	All
			F690501-RF-RTL005197 (LTE ULCA)		F690501-RF-RTL005289 (LTE ULCA)	
			F690501-RF-RTL005199 (NR FDD)		F690501-RF-RTL005290 (NR FDD)	
			F690501-RF-RTL005201 (NR TDD)		F690501-RF-RTL005291 (NR TDD)	

1.12. Spot Check Data

After confirming through in the band that the performance of the FCC ID: YZP-GN1000 remains representative of FCC ID: YZP-GN1000.

The test data of FCC ID: YZP-GN1000 being submitted for this application to cover LTE features.

Test item	Band	Frequency (MHz)	Limit	Original model	Spot check model	Deviation (dB)
				LTD-GN1000	LTD-GN3000	
				FCC ID: YZP-GN1000	FCC ID: YZP-GN3000	
Conducted Output Power	5B	829.0	2 W E.I.R.P.	23.21 dB m	23.18 dB m	-0.03
		836.2				
	7C	2 530.1	2 W E.I.R.P.	23.52 dB m	23.37 dB m	-0.15
		2 544.5				
	41C	2 667.5	7 W E.R.P.	23.40 dB m	23.45 dB m	0.05
		2 682.5				
	66B	1 717.5	100 W E.R.P.	23.13 dB m	23.24 dB m	0.11
		1 726.8				
	66C	1 720.0	2 W E.I.R.P.	23.05 dB m	22.74 dB m	-0.31
		1 734.4				
Band edge	5B	826.5	-13 dB m	-17.01 dB m	-19.32 dB m	-2.31
		830.4				
	7C	2 540.2	-25 dB m	-28.77 dB m	-30.63 dB m	-1.86
		2 560.0				
	41C	2 503.8	-13 dB m	-25.73 dB m	-28.19 dB m	-2.46
		2 520.9				
	66B	1 715.0	-13 dB m	-23.96 dB m	-25.12 dB m	-1.16
		1 722.2				
	66C	1 717.5	-25 dB m	-25.11 dB m	-25.43 dB m	-0.32
		1 732.5				
Radiated Spurious Emissions	5B	829.0	-13 dB m	-25.50 dB m	-28.05 dB m	-2.55
		836.2				
	7C	2 530.1	-25 dB m	-37.18 dB m	-37.73 dB m	-0.55
		2 544.5				
	41C	2 667.5	-25 dB m	-37.99 dB m	-38.14 dB m	-0.15
		2 682.5				
	66B	1 717.5	-13 dB m	-40.71 dB m	-43.20 dB m	-2.49
		1 726.8				
	66C	1 720.0	-13 dB m	Not detected	Not detected	-
		1 734.4				
	2A-5A	1 860.0	-13 dB m	-42.63 dB m	-42.86 dB m	-0.23
		836.5				
	4A-5A	1 732.5	-13 dB m	-39.33 dB m	-37.70 dB m	1.63
		836.5				
	5A-7A	836.0	-13 dB m	-36.49 dB m	-36.25 dB m	0.24
		2 535.0				
	5A-25A	836.5	-13 dB m	-26.78 dB m	-26.42 dB m	0.36
		1 860.0				
5A-66A	836.5	-13 dB m	-37.47 dB m	-37.84 dB m	-0.37	
	1 745.0					
25A-26A	1 860.0	-13 dB m	-20.58 dB m	-20.83 dB m	-0.25	
	831.5					

Test item	Band	Frequency (MHz)	Limit	Original model	Spot check model	Deviation (dB)
				LTD-GN1000	LTD-GN3000	
				FCC ID: YZP-GN1000	FCC ID: YZP-GN3000	
Conducted Spurious Emission	5B	829.0	-13 dB m	-18.15 dB m	-18.58 dB m	-0.43
		836.2				
	7C	2 530.1	-25 dB m	-35.02 dB m	-35.30 dB m	-0.28
		2 544.5				
	41C	2 667.5	-25 dB m	-34.88 dB m	-35.51 dB m	-0.63
		2 682.5				
	66B	1 717.5	-13 dB m	-18.40 dB m	-18.22 dB m	0.18
		1 726.8				
	66C	1 720.0	-13 dB m	-18.25 dB m	-18.63 dB m	-0.38
		1 734.4				
Peak-Average Ratio	5B	831.6	-13 dB	7.30 dB	7.36 dB	0.06
		841.5				
	7C	2 525.1		7.28 dB	7.13 dB	-0.15
		2 554.9				
	41C	2 585.9		7.19 dB	7.01 dB	-0.18
		2 597.9				
	66B	1 750.3		7.25 dB	7.19 dB	-0.06
		1 757.5				
	66C	1 747.6		7.33 dB	7.22 dB	-0.11
		1 764.7				
Test item	Band	Frequency (MHz)	Limit	Original model	Spot check model	Deviation (ppm)
				LTD-GN1000	LTD-GN3000	
				FCC ID: YZP-GN1000	FCC ID: YZP-GN3000	
Stability	5B	834.1	±2.5 ppm	0.017 98 ppm	0.008 14 ppm	-0.009 84
		838.0		0.007 46 ppm	0.005 63 ppm	-0.001 83
	7C	2 525.6		-0.005 16 ppm	0.007 96 ppm	0.013 12
		2 540.0		0.008 56 ppm	0.005 36 ppm	-0.003 20
	41C	2 583.8		0.020 38 ppm	0.012 40 ppm	-0.007 98
		2 595.5		-0.004 91 ppm	0.008 56 ppm	0.013 47
	66B	1 752.6		-0.013 77 ppm	0.005 36 ppm	0.019 13
		1 757.4		0.011 30 ppm	0.013 11 ppm	0.001 81
	66C	1 749.9		-0.011 99 ppm	0.006 68 ppm	0.018 67
		1 759.9		-0.002 94 ppm	0.005 36 ppm	0.008 30

Test item	Band	Frequency (MHz)	Bandwidth	Original model		Spot check model		Deviation	
				LTD-GN1000		LTD-GN3000		(MHz)	
				QPSK (MHz)	16QAM (MHz)	QPSK (MHz)	16QAM (MHz)	QPSK	16QAM
Occupied Bandwidth	5B	835.0	Lowest Bandwidth	7.473	7.453	7.453	7.473	-0.020	0.020
		838.9							
		831.6	Highest Bandwidth	18.781	18.741	18.781	18.781	0.000	0.040
		841.5							
	7C	2 527.5	Lowest Bandwidth	22.927	22.977	23.077	23.127	0.150	0.150
		2 542.5							
		2 525.1	Highest Bandwidth	37.642	37.722	37.882	37.882	0.240	0.160
		2 544.9							
	41C	2 588.1	Lowest Bandwidth	23.176	23.127	23.176	23.176	0.000	0.049
		2 600.1							
		2 583.1	Highest Bandwidth	37.802	37.722	37.882	37.962	0.080	0.240
		2 602.9							
	66B	1 752.6	Lowest Bandwidth	9.251	9.251	9.231	9.231	-0.020	-0.020
		1 757.4							
		1 750.1	Highest Bandwidth	18.741	18.262	18.821	18.821	0.080	0.559
		1 760.0							
	66C	1 750.1	Lowest Bandwidth	23.027	23.077	23.127	23.127	0.100	0.050
		1 762.1							
		1 745.1	Highest Bandwidth	37.882	37.562	37.722	37.802	-0.160	0.240
		1 764.9							

Note;

Comparison of two models, upper deviation is within 3 dB range and all test results are under FCC technical limits.

1.13. The Test Channel Details

The EUT supports with carrier aggregation uplink. Intra-Band contiguous specification as below

E-UTRA Intra-Band CA configuration / Bandwidth combination set			
E-UTRA CA Configuration	Channel bandwidth for carrier (MHz)	Channel bandwidth for carrier (MHz)	Maximum aggregated bandwidth (MHz)
CA_5B	3	5	8
	5	3	
	5	10	15
	10	5	
	10	10	
CA_7C	10	20	30
	20	10	
	15	15	
	15	10	25
	20	15	35
	20	20	40
CA_38C	15	15	30
	20	20	40
CA_41C	5	20	25
	20	5	
	10	15	
	15	10	
	10	20	30
	20	10	
	15	15	
	15	20	
20	15	35	
20	20	40	
CA_66B	5	5	10
	5	10	15
	10	5	
	5	15	
	15	5	20
10	10		
CA_66C	10	15	25
	15	10	
	20	5	
	5	20	30
	10	20	
	20	10	
	15	15	
	15	20	35
	20	15	
20	20	40	

1.14. Measurement Configuration

Intra-Band

Test Items	Band	Test Channel			Bandwidth (MHz)								Modulation				RB #		
		Low	Mid	High	8	10	15	20	25	30	35	40	QPSK	16QAM	64QAM	256QAM	1	Half	Full
Conducted Output Power	5B	V	V	V	V		V	V					V	V	-	-	V	-	V
	7C	V	V	V					V	V	V	V	V	V	-	-	V	-	V
	38C	V	V	V						V		V	V	V	-	-	V	-	V
	41C	V	V	V					V	V	V	V	V	V	-	-	V	-	V
	66B	V	V	V		V	V	V					V	V	-	-	V	-	V
	66C	V	V	V					V	V	V	V	V	V	-	-	V	-	V
Frequency Stability	5B	-	V	-	V		V	V					V	-	-	-	-	-	V
	7C	-	V	-					V	V	V	V	V	-	-	-	-	-	V
	38C	-	V	-						V		V	V	-	-	-	-	-	V
	41C	-	V	-					V	V	V	V	V	-	-	-	-	-	V
	66B	-	V	-		V	V	V					V	-	-	-	-	-	V
	66C	-	V	-					V	V	V	V	V	-	-	-	-	-	V
Occupied Bandwidth	5B	-	V	-	V		V	V					V	V	-	-	-	-	V
	7C	-	V	-					V	V	V	V	V	V	-	-	-	-	V
	38C	-	V	-						V		V	V	V	-	-	-	-	V
	41C	-	V	-					V	V	V	V	V	V	-	-	-	-	V
	66B	-	V	-		V	V	V					V	V	-	-	-	-	V
	66C	-	V	-					V	V	V	V	V	V	-	-	-	-	V
Peak-to-Average Ratio	5B	V	V	V	V		V	V					-	-	-	V	-	-	V
	7C	V	V	V					V	V	V	V	-	-	-	V	-	-	V
	38C	V	V	V						V		V	-	-	-	V	-	-	V
	41C	V	V	V					V	V	V	V	-	-	-	V	-	-	V
	66B	V	V	V		V	V	V					-	-	-	V	-	-	V
	66C	V	V	V					V	V	V	V	-	-	-	V	-	-	V

Test Items	Band	Test Channel			Bandwidth (MHz)								Modulation				RB #		
		Low	Mid	High	8	10	15	20	25	30	35	40	QPSK	16QAM	64QAM	256QAM	1	Half	Full
Band edge	5B	V	-	V	V		V	V					V	V	-	-	-	-	V
	7C	V	-	V					V	V	V	V	V	V	-	-	-	-	V
	38C	V	-	V						V		V	V	V	-	-	-	-	V
	41C	V	-	V					V	V	V	V	V	V	-	-	-	-	V
	66B	V	-	V		V	V	V					V	V	-	-	-	-	V
	66C	V	-	V					V	V	V	V	V	V	-	-	-	-	V
Spurious at antenna terminal & Radiated Spurious Emissions	5B	V	V	V	Worst Case														
	7C	V	V	V	Worst Case														
	38C	V	V	V	Worst Case														
	41C	V	V	V	Worst Case														
	66B	V	V	V	Worst Case														
	66C	V	V	V	Worst Case														

Inter-Band

Test Items	Band	Test Channel			Bandwidth (MHz)						Modulation				RB #		
		Low	Mid	High	1.4	3	5	10	15	20	QPSK	16QAM	64QAM	256QAM	1	Half	Full
Radiated Spurious Emissions	2A-5A	V	V	V	Worst Case												
	4A-5A	V	V	V	Worst Case												
	5A-7A	V	V	V	Worst Case												
	5A-25A	V	V	V	Worst Case												
	5A-66A	V	V	V	Worst Case												
	25A-26A	V	V	V	Worst Case												

1.15. Measurement Uncertainty

Where relevant, the following measurement uncertainty levels have been estimated for tests performed on the apparatus:

Parameter	Uncertainty	
Conducted Output Power	0.33 dB	
Occupied Bandwidth	0.05 MHz	
Conducted Spurious Emissions	0.99 dB	
Peak to Average Ratio	0.66 dB	
Frequency Stability	116 Hz	
Radiated Emission, 9 kHz to 30 MHz	H	3.60 dB
	V	3.60 dB
Radiated Emission, below 1 GHz	H	4.60 dB
	V	4.90 dB
Radiated Emission, above 1 GHz	H	3.90 dB
	V	3.80 dB

All measurement uncertainty values are shown with a coverage factor of $k=2$ to indicate a 95 % level of confidence.

1.16. Test Report Revision

Revision	Report Number	Date of Issue	Description
0	F690501-RF-RTL005289	2024.08.20	Initial

1.17. Antenna Designation

Ant. Type	Ant. No	Support Band	
		LTE	NR
Dipole Antenna	Ant.1	2, 4, 5, 7, 25, 26, 38, 41, 66	2, 5, 7, 25, 26, 38, 41, 66
	Ant.2		77, 78

Band	Operating Frequency (MHz)	Antenna Peak Gain (dB i)	
		Ant. 1	Ant. 2
LTE 25/2 NR 25/2 GSM 1 900	1 850 ~ 1 915	1.90	
LTE 66/4 NR 66	1 710 ~ 1 780	4.20	
LTE 26/5 NR 26/5 WCDMA V GSM 850	824 ~ 849	1.99	
LTE 26 NR 26	814 ~ 824	0.72	
LTE 7 NR 7	2 500 ~ 2 570	4.43	
LTE 38 NR 38	2 570 ~ 2 620	3.35	
LTE 41 NR 41	2 496 ~ 2 690	4.43	
NR 77	3 450 ~ 3 550		4.69
	3 700 ~ 3 980		4.90
NR 78	3 450 ~ 3 550		4.69
	3 700 ~ 3 800		4.90

1.18. Emission Designator and Max Power

Band	Band width (MHz)	Modulation	Low Freq. (MHz)	Upper Freq. (MHz)	Conducted Average (dB m)	Ant. Gain (dB i)	E.R.P. / E.I.R.P. Average (dB m)	E.R.P. / E.I.R.P. Average (W)	Emission Designator		
CA_5B	3+5	QPSK	825.6	846.5	23.11	1.99	22.95	0.197	7M47G7D		
		16QAM			22.69		22.53	0.179	7M43D7D		
	5+3	QPSK	826.5	847.4	23.15		22.99	0.199	7M47G7D		
		16QAM			22.78		22.62	0.183	7M45D7D		
	5+10	QPSK	826.8	844.0	23.12		22.96	0.198	13M8G7D		
		16QAM			22.68		22.52	0.179	14M0D7D		
	10+5	QPSK	829.0	846.2	23.21		23.05	0.202	13M9G7D		
		16QAM			22.79		22.63	0.183	13M8D7D		
	10+10	QPSK	829.0	844.0	23.16		23.00	0.200	18M8G7D		
		16QAM			22.92		22.76	0.189	18M7D7D		
	CA_7C	10+20	QPSK	2 505.5	2 560.0		23.41	4.43	27.84	0.608	27M9G7D
			16QAM				23.05		27.48	0.560	27M9D7D
20+10		QPSK	2 510.0	2 564.5	23.52	27.95	0.624		27M9G7D		
		16QAM			22.89	27.32	0.540		27M9D7D		
15+15		QPSK	2 507.5	2 562.5	23.31	27.74	0.594		28M5G7D		
		16QAM			22.87	27.30	0.537		28M5D7D		
15+10		QPSK	2 507.5	2 564.7	23.45	27.88	0.614		22M9G7D		
		16QAM			23.11	27.54	0.568		23M0D7D		
15+20		QPSK	2 507.8	2 560.0	23.33	27.76	0.597		32M9G7D		
		16QAM			22.94	27.37	0.546		32M7D7D		
20+15		QPSK	2 510.0	2 562.2	23.34	27.77	0.598		32M6G7D		
		16QAM			23.05	27.48	0.560		32M8D7D		
20+20		QPSK	2 510.0	2 560.0	23.43	27.86	0.611		37M6G7D		
		16QAM			23.02	27.45	0.556		37M7D7D		
CA_38C		15+15	QPSK	2 577.5	2 612.5	22.73	3.35		26.08	0.406	28M7G7D
			16QAM			22.36			25.71	0.372	28M7D7D
	20+20	QPSK	2 580.0	2 610.0	22.69	26.04		0.402	37M6G7D		
		16QAM			22.33	25.68		0.370	37M8D7D		

Band	Band width (MHz)	Modulation	Low Freq. (MHz)	Upper Freq. (MHz)	Conducted Average (dB m)	Ant. Gain (dB i)	E.R.P. / E.I.R.P. Average (dB m)	E.R.P. / E.I.R.P. Average (W)	Emission Designator
CA_41C	5+20	QPSK	2 499.3	2 680.0	23.38	4.43	27.81	0.604	22M9G7D
		16QAM			22.45		26.88	0.488	22M8D7D
	20+5	QPSK	2 506.0	2 686.7	23.31		27.74	0.594	22M8G7D
		16QAM			22.32		26.75	0.473	22M8D7D
	10+15	QPSK	2 501.3	2 682.5	23.13		27.56	0.570	23M1G7D
		16QAM			22.21		26.64	0.461	23M0D7D
	15+10	QPSK	2 503.5	2 684.7	23.18		27.61	0.577	23M2G7D
		16QAM			22.15		26.58	0.455	23M1D7D
	10+20	QPSK	2 501.5	2 680.0	23.39		27.82	0.605	28M1G7D
		16QAM			22.08		26.51	0.448	28M1D7D
	20+10	QPSK	2 506.0	2 684.5	23.23		27.66	0.583	28M1G7D
		16QAM			22.09		26.52	0.449	28M1D7D
	15+15	QPSK	2 503.5	2 682.5	23.40		27.83	0.607	28M8G7D
		16QAM			22.05		26.48	0.445	28M6D7D
	15+20	QPSK	2 503.8	2 680.0	23.32		27.75	0.596	32M9G7D
		16QAM			22.12		26.55	0.452	33M0D7D
	20+15	QPSK	2 506.0	2 682.2	23.21		27.64	0.581	32M9G7D
		16QAM			22.05		26.48	0.445	33M0D7D
	20+20	QPSK	2 506.0	2 680.0	23.16		27.59	0.574	37M8G7D
		16QAM			22.45		26.88	0.488	37M7D7D

Band	Band width (MHz)	Modulation	Low Freq. (MHz)	Upper Freq. (MHz)	Conducted Average (dB m)	Ant. Gain (dB i)	E.R.P. / E.I.R.P. Average (dB m)	E.R.P. / E.I.R.P. Average (W)	Emission Designator		
CA_66B	5+5	QPSK	1 712.5	1 777.5	23.06	4.20	27.26	0.532	9M25G7D		
		16QAM			22.67		26.87	0.486	9M25D7D		
	5+10	QPSK	1 712.8	1 775.0	22.76		26.96	0.497	13M9G7D		
		16QAM			22.31		26.51	0.448	13M8D7D		
	10+5	QPSK	1 715.0	1 777.2	23.11		27.31	0.538	13M9G7D		
		16QAM			22.69		26.89	0.489	14M0D7D		
	5+15	QPSK	1 713.0	1 772.5	23.12		27.32	0.540	18M1G7D		
		16QAM			22.71		26.91	0.491	18M1D7D		
	15+5	QPSK	1 717.5	1 777.0	23.13		27.33	0.541	18M3G7D		
		16QAM			22.74		26.94	0.494	18M3D7D		
	10+10	QPSK	1 715.0	1 775.0	22.98		27.18	0.522	18M7G7D		
		16QAM			22.49		26.69	0.467	18M3D7D		
	CA_66C	10+15	QPSK	1 715.3	1 772.5		22.75	4.20	26.95	0.495	23M0G7D
			16QAM				22.43		26.63	0.460	23M1D7D
15+10		QPSK	1 717.5	1 774.7	22.56	26.76	0.474		23M0G7D		
		16QAM			22.09	26.29	0.426		23M1D7D		
10+20		QPSK	1 715.5	1 770.0	22.59	26.79	0.478		27M9G7D		
		16QAM			22.34	26.54	0.451		28M0D7D		
20+10		QPSK	1 720.0	1 774.5	23.05	27.25	0.531		28M1G7D		
		16QAM			22.54	26.74	0.472		28M1D7D		
15+15		QPSK	1 717.5	1 772.5	22.73	26.93	0.493		28M6G7D		
		16QAM			22.23	26.43	0.440		28M6D7D		
15+20		QPSK	1 717.8	1 770.0	22.67	26.87	0.486		32M8G7D		
		16QAM			22.32	26.52	0.449		32M9D7D		
20+15		QPSK	1 720.0	1 772.2	22.84	27.04	0.506		33M1G7D		
		16QAM			22.11	26.31	0.428		32M9D7D		
20+5		QPSK	1 720.0	1 776.7	22.80	27.00	0.501		22M8G7D		
		16QAM			22.32	26.52	0.449		22M8D7D		
5+20		QPSK	1 713.3	1 770.0	22.78	26.98	0.499		22M7G7D		
		16QAM			22.32	26.52	0.449		22M8D7D		
20+20		QPSK	1 720.0	1 770.0	22.79	26.99	0.500		37M9G7D		
		16QAM			22.31	26.51	0.448		37M6D7D		

2. E.R.P. / E.I.R.P. & Radiated Spurious Emissions

2.1. Test setup

The diagram below shows the test setup that is utilized to make the measurements for emission from 9 kHz to 30 MHz.

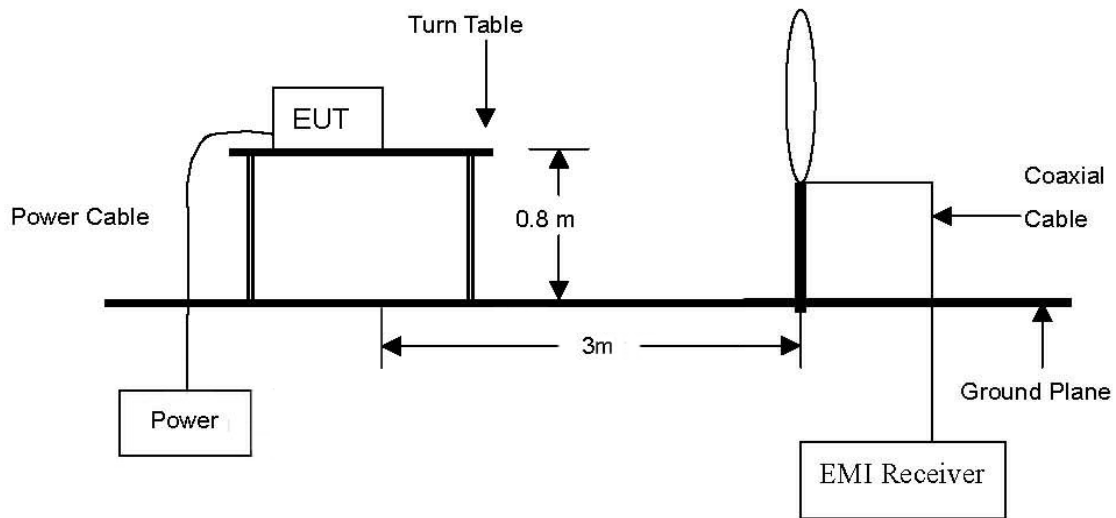

The diagram below shows the test setup that is utilized to make the measurements for emission from 30 MHz to 1 GHz Emissions.

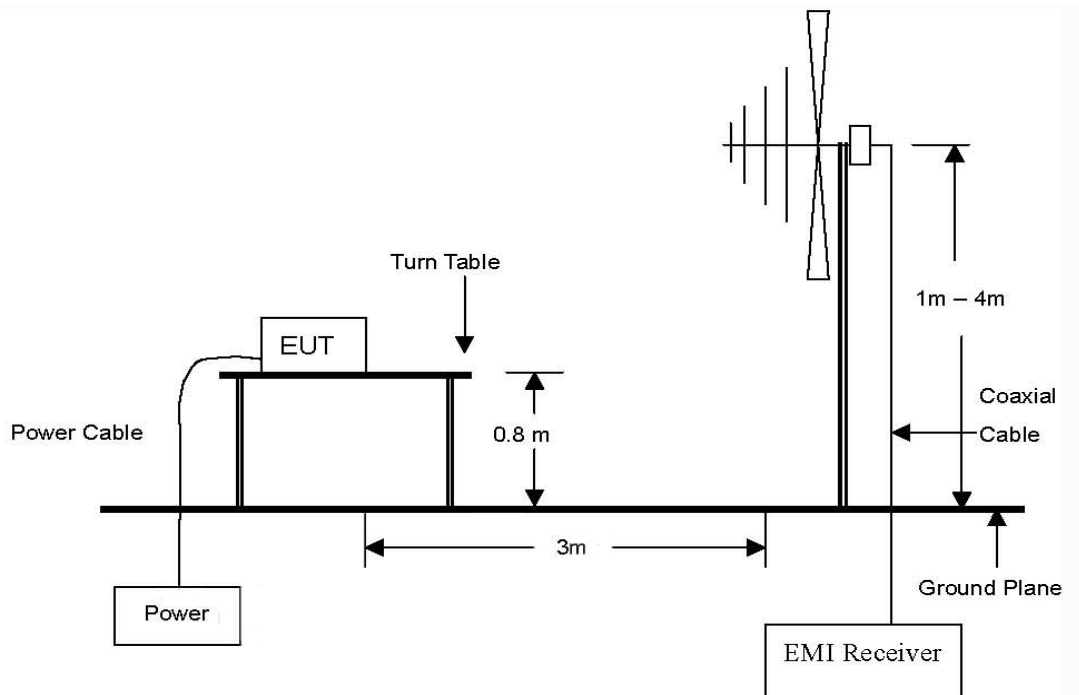

The diagram below shows the test setup that is utilized to make the measurements for emission from 1 GHz to 26 GHz Emissions.

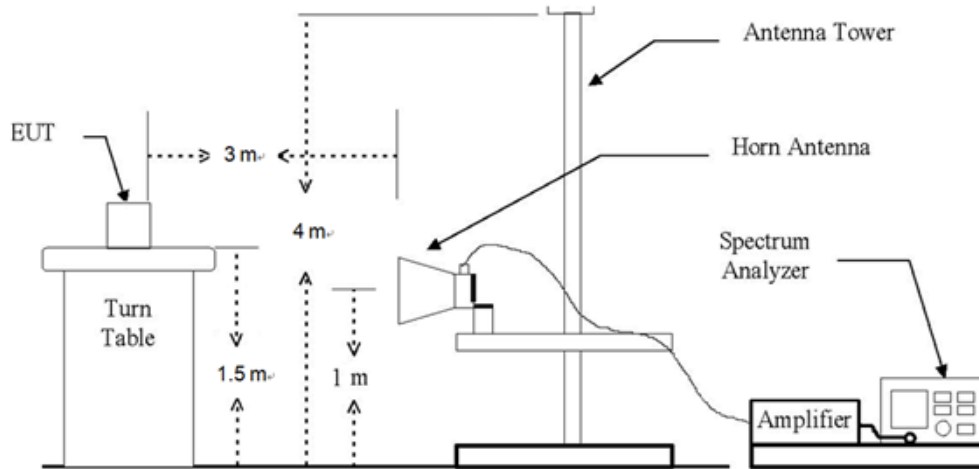

2.2. Limit

2.2.1. Limit of E.R.P. / E.I.R.P.

- §22.913(a)(5), the ERP of mobile transmitters and auxiliary test transmitters must not exceed 7 watts.
- §24.232(c), mobile and portable stations are limited to 2 watts EIRP and the equipment must employ a means for limiting power to the minimum necessary for successful communications.
- §27.50(d)(4), fixed, mobile, and portable (hand-held) stations operating in the 1 710-1 755 MHz band and mobile and portable stations operating in the 1 695-1 710 MHz and 1 755-1 780 MHz bands are limited to 1 watt EIRP.
- §27.50(h)(2), Mobile and other user stations. Mobile stations are limited to 2.0 watts EIRP. All user stations are limited to 2.0 watts transmitter output power.
- §90.635(b), the maximum output power of the transmitter for mobile stations is 100 watts (20 dBW).

2.2.2. Limit of Spurious Radiated Emission

- §22.917(a), the power of any emission outside of the authorized operating frequency ranges must be attenuated below the transmitting power (P) by a factor of at least $43 + 10\log(P)$ dB.

- §24.238(a), the power of any emission outside of the authorized operating frequency ranges must be attenuated below the transmitting power (P) by a factor of at least $43 + 10 \log(P)$ dB.

- §27.53(h)(1), for operations in the 1 695-1 710 MHz, 1 710-1 755 MHz, 1 755-1 780 MHz, 1 915-1 920 MHz, 1 995-2 000 MHz, 2 000-2 020 MHz, 2 110-2 155 MHz, 2 155-2 180 MHz, and 2 180-2 200 bands, the power of any emission outside a licensee's frequency block shall be attenuated below the transmitter power (P) in watts by at least $43 + 10 \log_{10} (P)$ dB.

- §27.53(m)(4), for mobile digital stations, the attenuation factor shall be not less than $40 + 10 \log_{10} (P)$ dB on all frequencies between the channel edge and 5 megahertz from the channel edge, $43 + 10 \log_{10} (P)$ dB on all frequencies between 5 megahertz and X megahertz from the channel edge, and $55 + 10 \log_{10} (P)$ dB on all frequencies more than X megahertz from the channel edge, where X is the greater of 6 megahertz or the actual emission bandwidth as defined in paragraph (m)(6) of this section. In addition, the attenuation factor shall not be less than $43 + 10 \log_{10} (P)$ dB on all frequencies between 2 490.5 MHz and 2 496 MHz and $55 + 10 \log_{10} (P)$ dB at or below 2 490.5 MHz. Mobile Satellite Service licensees operating on frequencies below 2 495 MHz may also submit a documented interference complaint against BRS licensees operating on channel BRS Channel 1 on the same terms and conditions as adjacent channel BRS or EBS licensees.

- §90.691(a), out-of-band emission requirement shall apply only to the "outer" channels included in an EA license and to spectrum adjacent to interior channels used by incumbent licensees. The emission limits are as follows:

(1) For any frequency removed from the EA licensee's frequency block by up to and including 37.5 kHz, the power of any emission shall be attenuated below the transmitter power (P) in watts by at least $116 \text{ Log}_{10} (f / 6.1)$ decibels or $50 + 10 \text{ Log}_{10} (P)$ decibels or 80 decibels, whichever is the lesser attenuation, where f is the frequency removed from the center of the outer channel in the block in kilohertz and where f is greater than 12.5 kHz.

(2) For any frequency removed from the EA licensee's frequency block greater than 37.5 kHz, the power of any emission shall be attenuated below the transmitter power (P) in watts by at least $43 + 10 \text{ Log}_{10} (P)$ decibels or 80 decibels, whichever is the lesser attenuation, where f is the frequency removed from the center of the outer channel in the block in kilohertz and where f is greater than 37.5 kHz.

2.3. Test Procedure

2.3.1. E.R.P. or E.I.R.P. from conducted RF output power

According to subclause 5.2.5.5 of ANSI C63.26-2015 E.R.P. and E.I.R.P. are defined as the product of the power supplied to the antenna and its gain.

The relevant equation for determining the E.R.P. or E.I.R.P. from the conducted RF output power measured using the guidance provided above is:

$$E.R.P. \text{ or } E.I.R.P. = P_{Meas} + G_T$$

where:

E.R.P. or E.I.R.P. = effective radiated power or equivalent isotropically radiated power, respectively (expressed in the same units as P_{Meas} , typically dBW or dBm);

P_{Meas} = measured transmitter output power or PSD, in dBm or dBW;

G_T = gain of the transmitting antenna, in dBd (ERP) or dBi (EIRP);

2.3.2. Radiated Spurious Emissions

The test based on ANSI/TIA 603E: 2016 and ANSI C63.26-2015 and KDB 971168 D01 Power Meas License Digital Systems v03r01.

1. On a test site, the EUT shall be placed at 0.8 m or 1.5 m height on a turn table, and in the position close to normal use as declared by the applicant.
2. The test antenna shall be oriented initially for vertical polarization located 3 m from EUT to correspond to the fundamental frequency of the transmitter.
3. The output of the test antenna shall be connected to the measuring receiver and the peak detector is used for the measurement.
4. Radiated spurious emissions measurement method was set as follows:
 RBW = 100 kHz for emissions below 1 GHz and 1 MHz for emissions above 1 GHz, VBW ≥ 3 x RBW,
 Detector = RMS, trace mode = max hold, per the guidelines of KDB 971168 D01 Power Meas License Digital Systems v03r01.
5. The transmitter shall be switched on, the measuring receiver shall be tuned to the frequency of the transmitter under test.
6. The test antenna shall be raised and lowered through the specified range of height until the maximum signal level is detected by the measuring receiver.
7. The transmitter shall be rotated through 360° in the horizontal plane, until the maximum signal level is detected by the measuring receiver.
8. The test antenna shall be raised and lowered again through the specified range of height until the maximum signal level is detected by the measuring receiver.
9. The maximum signal level detected by the measuring receiver shall be noted.
10. In necessary, the input attenuator setting on the measuring receiver shall be adjusted in order to increase the sensitivity of the measuring receiver.
11. The test antenna shall be raised and lowered through the specified range of height to ensure that the maximum signal is received.
12. The measurement shall be repeated with the test antenna orientated for horizontal polarization.

2.4. Test results

Ambient temperature : (23 ± 1) °C
 Relative humidity : 47 % R.H.

2.4.1. E.R.P. / E.I.R.P.

Band	Frequency (MHz)	Maximum Conducted Power (dB m)	Maximum Conducted Power (W)	Antenna Gain (dB i)	Maximum E.I.R.P. (dB m)	Maximum E.I.R.P. (W)	Maximum E.R.P. (dB m)	Maximum E.R.P. (W)	Limit
5B	824 ~ 849	23.21	0.209	1.99	25.20	0.331	23.05	0.202	7 W E.R.P.
7C	2 500 ~ 2 570	23.52	0.225	4.43	27.95	0.624			2 W E.I.R.P.
38C	2 570 ~ 2 620	22.73	0.187	3.35	26.08	0.406			2 W E.I.R.P.
41C	2 496 ~ 2 690	23.40	0.219	4.43	27.83	0.607			2 W E.I.R.P.
66B	1 710 ~ 1 755	23.13	0.206	4.20	27.33	0.541			1 W E.I.R.P.
66C	1 710 ~ 1 755	23.05	0.202	4.20	27.25	0.531			1 W E.I.R.P.

Remark;

1. E.I.R.P. (dB m) = Maximum Conducted Power (dB m) + Antenna Gain (dB i)
2. E.R.P. (dB m) = E.I.R.P. (dB m) - 2.15 (dB); where E.R.P. and E.I.R.P. are expressed in consistent units.

2.4.2. Radiated spurious emissions
Intra-Band
ULCA 5B

Frequency (MHz)	Measured Level (dB μ V)	Ant. Pol.	AF (dB/m)	AMP+CL (dB)	E (dB μ V/m)	CF (dB)	E.R.P. (dB m)	Limit (dB m)	Margin (dB)
PCC 10 MHz + SCC 5 MHz_ Low Channel (829.0 MHz + 836.2 MHz)									
1 666.85	52.43	H	26.10	-36.32	42.21	-97.41	-55.21	-13	42.21
1 666.63	57.25	V	26.10	-36.33	47.02	-97.41	-50.39	-13	37.39
2 500.40	72.97	H	28.40	-34.40	66.97	-97.41	-30.44	-13	17.44
2 500.10	77.92	V	28.40	-34.40	71.92	-97.41	-25.50	-13	12.50
4 167.00	55.41	H	32.10	-31.06	56.45	-97.41	-40.96	-13	27.96
4 167.08	59.01	V	32.10	-31.06	60.05	-97.41	-37.36	-13	24.36
5 833.98	49.92	H	34.37	-28.83	55.46	-97.41	-41.95	-13	28.95
5 833.80	53.90	V	34.37	-28.83	59.44	-97.41	-37.97	-13	24.97
Above 5 900.00	Not detected	-	-	-	-	-	-	-	-
PCC 10 MHz + SCC 5 MHz_ Middle Channel (834.0 MHz + 841.2 MHz)									
1 676.83	50.68	H	26.28	-36.19	40.77	-97.41	-56.64	-13	43.64
1 676.82	55.17	V	26.28	-36.19	45.26	-97.41	-52.15	-13	39.15
2 515.40	68.41	H	28.46	-34.35	62.52	-97.41	-34.89	-13	21.89
2 515.26	68.42	V	28.46	-34.35	62.53	-97.41	-34.89	-13	21.89
4 192.12	52.96	H	32.10	-31.20	53.86	-97.41	-43.55	-13	30.55
4 192.10	58.97	V	32.10	-31.20	59.87	-97.41	-37.54	-13	24.54
5 868.86	48.94	H	34.48	-28.60	54.82	-97.41	-42.59	-13	29.59
5 869.04	52.38	V	34.48	-28.60	58.26	-97.41	-39.15	-13	26.15
Above 5 900.00	Not detected	-	-	-	-	-	-	-	-
PCC 10 MHz + SCC 5 MHz_ High Channel (839.0 MHz + 846.2 MHz)									
1 686.85	50.68	H	26.46	-36.23	40.91	-97.41	-56.50	-13	43.50
1 686.78	55.17	V	26.46	-36.23	45.40	-97.41	-52.01	-13	39.01
2 530.34	68.41	H	28.52	-34.18	62.75	-97.41	-34.66	-13	21.66
2 530.18	68.42	V	28.52	-34.19	62.75	-97.41	-34.67	-13	21.67
4 216.88	49.10	H	32.10	-29.53	51.67	-97.41	-45.74	-13	32.74
4 217.04	54.72	V	32.10	-29.51	57.31	-97.41	-40.10	-13	27.10
5 903.80	47.13	H	34.60	-26.73	55.00	-97.41	-42.41	-13	29.41
5 903.86	49.17	V	34.60	-26.73	57.04	-97.41	-40.37	-13	27.37
Above 6 000.00	Not detected	-	-	-	-	-	-	-	-

ULCA_7C

Frequency (MHz)	Measured Level (dB μ V)	Ant. Pol.	AF (dB/m)	AMP+CL (dB)	E (dB μ V/m)	CF (dB)	E.I.R.P. (dB m)	Limit (dB m)	Margin (dB)
PCC 20 MHz + SCC 10 MHz_Low Channel (2 510.0 MHz + 2 524.4 MHz)									
5 037.48	51.58	V	33.40	-28.59	56.39	-95.26	-38.87	-25	13.87
7 556.66	42.54	V	36.00	-27.05	51.49	-95.26	-43.77	-25	18.77
Above 7 600.00	Not detected	-	-	-	-	-	-	-	-
PCC 20 MHz + SCC 10 MHz_Middle Channel (2 530.1 MHz + 2 544.5 MHz)									
5 077.90	54.55	V	33.46	-29.93	58.08	-95.26	-37.18	-25	12.18
7 617.05	42.96	V	36.00	-27.56	51.40	-95.26	-43.86	-25	18.86
Above 7 700.00	Not detected	-	-	-	-	-	-	-	-
PCC 20 MHz + SCC 10 MHz_High Channel (2 550.1 MHz + 2 564.5 MHz)									
5 118.20	52.39	V	33.54	-29.96	55.97	-95.26	-39.29	-25	14.29
7 676.95	38.85	V	35.95	-26.46	48.34	-95.26	-46.93	-25	21.93
Above 7 700.00	Not detected	-	-	-	-	-	-	-	-

ULCA_38C

Frequency (MHz)	Measured Level (dB μ V)	Ant. Pol.	AF (dB/m)	AMP+CL (dB)	E (dB μ V/m)	CF (dB)	E.R.P. (dB m)	Limit (dB m)	Margin (dB)
PCC 15 MHz + SCC 15 MHz_Low Channel (2 577.5 MHz + 2 592.5 MHz)									
Below 1 000.00	Not detected	-	-	-	-	-	-	-	-
Above 1 000.00	Not detected	-	-	-	-	-	-	-	-
PCC 15 MHz + SCC 15 MHz_Middle Channel (2 587.5 MHz + 2 602.5 MHz)									
Below 1 000.00	Not detected	-	-	-	-	-	-	-	-
Above 1 000.00	Not detected	-	-	-	-	-	-	-	-
PCC 15 MHz + SCC 15 MHz_High Channel (2 597.5 MHz + 2 612.5 MHz)									
Below 1 000.00	Not detected	-	-	-	-	-	-	-	-
Above 1 000.00	Not detected	-	-	-	-	-	-	-	-

ULCA_41C

Frequency (MHz)	Measured Level (dB μ V)	Ant. Pol.	AF (dB/m)	AMP+CL (dB)	E (dB μ V/m)	CF (dB)	E.I.R.P. (dB m)	Limit (dB m)	Margin (dB)
PCC 15 MHz + SCC 15 MHz_Low Channel (2 503.5 MHz + 2 518.5 MHz)									
5 020.44	36.74	V	33.40	-28.82	41.32	-95.26	-53.94	-25	28.94
7 530.52	39.13	H	36.04	-27.41	47.76	-95.26	-47.50	-25	22.50
7 530.16	44.23	V	36.04	-27.42	52.85	-95.26	-42.41	-25	17.41
Above 7 600.00	Not detected	-	-	-	-	-	-	-	-
PCC 15 MHz + SCC 15 MHz_Middle Channel (2 585.5 MHz + 2 600.5 MHz)									
5 184.20	38.42	V	33.67	-29.47	42.62	-95.26	-52.64	-25	27.64
7 773.12	34.65	H	36.00	-26.30	44.35	-95.26	-50.91	-25	25.91
7 776.34	39.08	V	36.00	-26.16	48.92	-95.26	-46.34	-25	21.34
Above 7 800.00	Not detected	-	-	-	-	-	-	-	-
PCC 15 MHz + SCC 15 MHz_High Channel (2 667.5 MHz + 2 682.5 MHz)									
5 348.20	40.48	V	34.00	-28.65	45.83	-95.26	-49.43	-25	24.43
8 022.42	43.24	H	36.20	-26.76	52.68	-95.26	-42.58	-25	17.58
8 022.64	47.82	V	36.20	-26.75	57.27	-95.26	-37.99	-25	12.99
Above 8 100.00	Not detected	-	-	-	-	-	-	-	-

ULCA_66B

Frequency (MHz)	Measured Level (dB μ V)	Ant. Pol.	AF (dB/m)	AMP+CL (dB)	E (dB μ V/m)	CF (dB)	E.I.R.P. (dB m)	Limit (dB m)	Margin (dB)
PCC 15 MHz + SCC 5 MHz_ Low Channel (1 717.5 MHz + 1 726.8 MHz)									
5 172.68	39.06	V	33.65	-29.26	43.45	-95.26	-51.81	-13	38.81
Above 5 200.00	Not detected	-	-	-	-	-	-	-	-
PCC 15 MHz + SCC 5 MHz_ Middle Channel (1 752.6 MHz + 1 761.9 MHz)									
5 277.99	44.17	V	33.91	-29.08	49.00	-95.26	-46.26	-13	33.26
Above 5 300.00	Not detected	-	-	-	-	-	-	-	-
PCC 15 MHz + SCC 5 MHz_ High Channel (1 767.7 MHz + 1 777.0 MHz)									
5 323.00	49.11	V	34.00	-28.56	54.55	-95.26	<u>-40.71</u>	-13	27.71
Above 5 400.00	Not detected	-	-	-	-	-	-	-	-

ULCA_66C

Frequency (MHz)	Measured Level (dB μ V)	Ant. Pol.	AF (dB/m)	AMP+CL (dB)	E (dB μ V/m)	CF (dB)	E.I.R.P. (dB m)	Limit (dB m)	Margin (dB)
PCC 20 MHz + SCC 10 MHz_ Low Channel (1 720.0 MHz + 1 734.4 MHz)									
Below 1 000.00	Not detected	-	-	-	-	-	-	-	-
Above 1 000.00	Not detected	-	-	-	-	-	-	-	-
PCC 20 MHz + SCC 10 MHz_ Middle Channel (1 750.1 MHz + 1 764.5 MHz)									
Below 1 000.00	Not detected	-	-	-	-	-	-	-	-
Above 1 000.00	Not detected	-	-	-	-	-	-	-	-
PCC 20 MHz + SCC 10 MHz_ High Channel (1 760.1 MHz + 1 774.5 MHz)									
Below 1 000.00	Not detected	-	-	-	-	-	-	-	-
Above 1 000.00	Not detected	-	-	-	-	-	-	-	-

**Inter-Band
 ULCA_2A-5A**

Frequency (MHz)	Measured Level (dB μ V)	Ant. Pol.	AF (dB/m)	AMP+CL (dB)	E (dB μ V/m)	CF (dB)	E.I.R.P. (dB m)	Limit (dB m)	Margin (dB)
PCC 20 MHz + SCC 10 MHz_ Low Channel (1 860.0 MHz + 829.0 MHz)									
3 533.01	54.00	V	31.17	-32.53	52.64	-95.26	-42.63	-13	29.63
4 562.25	45.66	V	32.00	-29.96	47.70	-95.26	-47.56	-13	34.56
5 606.63	44.10	H	34.10	-27.40	50.80	-95.26	-44.46	-13	31.46
5 606.90	44.32	V	34.10	-27.36	51.06	-95.26	-44.20	-13	31.20
Above 5 700.00	Not detected	-	-	-	-	-	-	-	-
PCC 20 MHz + SCC 10 MHz_ Middle Channel (1 880.0 MHz + 836.5 MHz)									
3 552.95	51.72	V	31.21	-32.45	50.48	-95.26	-44.78	-13	31.78
4 609.96	45.53	V	32.02	-29.72	47.83	-95.26	-47.43	-13	34.43
5 666.78	42.09	H	34.10	-29.07	47.12	-95.26	-48.14	-13	35.14
5 666.81	40.69	V	34.10	-29.07	45.72	-95.26	-49.55	-13	36.55
Above 5 700.00	Not detected	-	-	-	-	-	-	-	-
PCC 20 MHz + SCC 10 MHz_ High Channel (1 900.0 MHz + 844.0 MHz)									
3 573.20	48.68	V	31.29	-31.69	48.28	-95.26	-46.98	-13	33.98
4 657.26	44.69	V	32.13	-30.09	46.73	-95.26	-48.53	-13	35.53
5 726.91	39.86	H	34.15	-28.77	45.24	-95.26	-50.02	-13	37.02
5 726.90	39.29	V	34.15	-28.77	44.67	-95.26	-50.60	-13	37.60
Above 5 800.00	Not detected	-	-	-	-	-	-	-	-

ULCA_4A-5A

Frequency (MHz)	Measured Level (dB μ V)	Ant. Pol.	AF (dB/m)	AMP+CL (dB)	E (dB μ V/m)	CF (dB)	E.I.R.P. (dB m)	Limit (dB m)	Margin (dB)
PCC 20 MHz + SCC 10 MHz_ Low Channel (1 720.0 MHz + 829.0 MHz)									
3 360.07	50.32	H	31.00	-32.75	48.57	-95.26	-46.69	-13	33.69
3 360.23	50.60	V	31.00	-32.76	48.84	-95.26	-46.42	-13	33.42
4 246.64	45.94	H	32.10	-30.11	47.93	-95.26	-47.33	-13	34.33
4 246.92	47.86	V	32.10	-30.13	49.83	-95.26	-45.43	-13	32.43
5 133.41	40.94	V	33.57	-29.87	44.64	-95.26	-50.62	-13	37.62
Above 5 200.00	Not detected	-	-	-	-	-	-	-	-
PCC 20 MHz + SCC 10 MHz_ Middle Channel (1 732.5 MHz + 836.5 MHz)									
3 387.78	51.35	H	31.00	-32.48	49.87	-95.26	-45.39	-13	32.39
3 387.79	53.33	V	31.00	-32.48	51.85	-95.26	-43.41	-13	30.41
4 279.28	53.75	H	32.10	-30.78	55.07	-95.26	-40.19	-13	27.19
4 279.33	54.61	V	32.10	-30.78	55.93	-95.26	-39.33	-13	26.33
5 170.74	42.36	V	33.64	-29.30	46.70	-95.26	-48.56	-13	35.56
Above 5 200.00	Not detected	-	-	-	-	-	-	-	-
PCC 20 MHz + SCC 10 MHz_ High Channel (1 745.0 MHz + 844.0 MHz)									
3 415.38	52.30	H	31.00	-31.60	51.70	-95.26	-43.56	-13	30.56
3 415.38	53.82	V	31.00	-31.60	53.22	-95.26	-42.04	-13	29.04
4 311.85	56.15	H	32.10	-30.69	57.56	-95.26	-37.70	-13	24.70
4 311.80	53.87	V	32.10	-30.69	55.28	-95.26	-39.99	-13	26.99
5 207.99	41.12	V	33.72	-30.00	44.84	-95.26	-50.42	-13	37.42
Above 5 300.00	Not detected	-	-	-	-	-	-	-	-

ULCA_5A-7A

Frequency (MHz)	Measured Level (dB μ V)	Ant. Pol.	AF (dB/m)	AMP+CL (dB)	E (dB μ V/m)	CF (dB)	E.I.R.P. (dB m)	Limit (dB m)	Margin (dB)
PCC 10 MHz + SCC 20 MHz_ Low Channel (829.0 MHz + 2 510.0 MHz)									
4 212.99	56.58	V	32.10	-29.91	58.77	-95.26	-36.49	-25	11.49
5 907.64	46.75	H	34.60	-26.88	54.47	-95.26	-40.80	-25	15.80
5 907.60	47.66	V	34.60	-26.88	55.38	-95.26	-39.88	-25	14.88
Above 6 000.00	Not detected	-	-	-	-	-	-	-	-
PCC 10 MHz + SCC 20 MHz_ Middle Channel (836.5 MHz + 2 535.0 MHz)									
4 255.80	56.14	V	32.10	-30.44	57.80	-95.26	-37.46	-25	12.46
5 919.95	49.13	H	34.60	-27.39	56.34	-95.26	-38.92	-25	13.92
5 967.81	48.93	V	34.64	-28.49	55.08	-95.26	-40.18	-25	15.18
Above 6 000.00	Not detected	-	-	-	-	-	-	-	-
PCC 10 MHz + SCC 20 MHz_ High Channel (844.0 MHz + 2 560.0 MHz)									
4 298.07	54.63	V	32.10	-30.61	56.12	-95.26	-39.14	-25	14.14
5 977.40	42.48	H	34.65	-28.97	48.16	-95.26	-47.10	-25	22.10
5 977.36	50.44	V	34.65	-28.97	56.12	-95.26	-39.14	-25	14.14
Above 6 000.00	Not detected	-	-	-	-	-	-	-	-

ULCA_5A-25A

Frequency (MHz)	Measured Level (dB μ V)	Ant. Pol.	AF (dB/m)	AMP+CL (dB)	E (dB μ V/m)	CF (dB)	E.I.R.P. (dB m)	Limit (dB m)	Margin (dB)
PCC 10 MHz + SCC 20 MHz_ Low Channel (829.0 MHz + 1 860.0 MHz)									
3 078.60	53.60	H	30.16	-32.82	50.94	-95.26	-44.33	-13	31.33
3 078.53	57.15	V	30.16	-32.82	54.49	-95.26	-40.77	-13	27.77
3 518.05	57.08	H	31.14	-32.51	55.71	-95.26	-39.56	-13	26.56
3 517.96	69.85	V	31.14	-32.51	68.48	-95.26	-26.78	-13	13.78
4 122.91	61.92	H	32.10	-29.31	64.71	-95.26	-30.55	-13	17.55
4 123.12	63.72	V	32.10	-29.32	66.50	-95.26	-28.76	-13	15.76
4 562.26	51.31	V	32.00	-29.96	53.35	-95.26	-41.91	-13	28.91
5 167.38	48.81	V	33.63	-29.38	53.06	-95.26	-42.21	-13	29.21
5 772.06	50.42	H	34.24	-28.84	55.82	-95.26	-39.44	-13	26.44
6 816.36	48.08	V	35.43	-27.30	56.21	-95.26	-39.05	-13	26.05
7 421.34	41.37	V	36.26	-27.72	49.91	-95.26	-45.35	-13	32.35
8 026.02	37.60	V	36.20	-26.70	47.10	-95.26	-48.16	-13	35.16
8 465.66	40.48	V	36.40	-27.57	49.31	-95.26	-45.95	-13	32.95
Above 8 500.00	Not detected	-	-	-	-	-	-	-	-
PCC 10 MHz + SCC 20 MHz_ Middle Channel (836.5 MHz + 1 882.5 MHz)									
3 100.94	53.92	H	30.20	-31.84	52.28	-95.26	-42.98	-13	29.98
3 101.22	58.52	V	30.20	-31.84	56.88	-95.26	-38.38	-13	25.38
3 555.70	61.04	H	31.22	-32.34	59.92	-95.26	-35.34	-13	22.34
3 555.68	68.00	V	31.22	-32.34	66.88	-95.26	-28.38	-13	15.38
4 160.36	63.78	H	32.10	-30.87	65.01	-95.26	-30.26	-13	17.26
4 160.42	65.48	V	32.10	-30.87	66.71	-95.26	-28.55	-13	15.55
4 614.96	48.25	V	32.03	-29.43	50.85	-95.26	-44.41	-13	31.41
5 219.62	47.92	V	33.74	-30.09	51.57	-95.26	-43.69	-13	30.69
5 824.62	52.37	H	34.35	-28.78	57.94	-95.26	-37.32	-13	24.32
6 884.25	48.20	V	35.50	-27.24	56.46	-95.26	-38.80	-13	25.80
7 488.84	43.71	V	36.12	-27.59	52.24	-95.26	-43.02	-13	30.02
8 093.48	40.24	V	36.29	-27.01	49.52	-95.26	-45.74	-13	32.74
8 547.74	42.54	V	36.50	-26.32	52.72	-95.26	-42.54	-13	29.54
Above 8 600.00	Not detected	-	-	-	-	-	-	-	-

Frequency (MHz)	Measured Level (dB μ V)	Ant. Pol.	AF (dB/m)	AMP+CL (dB)	E (dB μ V/m)	CF (dB)	E.I.R.P. (dB m)	Limit (dB m)	Margin (dB)
PCC 10 MHz + SCC 20 MHz_ High Channel (844.0 MHz + 1 905.0 MHz)									
3 123.61	54.38	H	30.25	-31.79	52.84	-95.26	-42.42	-13	29.42
3 123.77	54.45	V	30.25	-31.79	52.91	-95.26	-42.35	-13	29.35
3 593.04	62.84	H	31.37	-31.08	63.13	-95.26	-32.13	-13	19.13
3 593.12	64.72	V	31.37	-31.08	65.01	-95.26	-30.25	-13	17.25
4 197.97	59.49	H	32.10	-31.17	60.42	-95.26	-34.84	-13	21.84
4 197.71	65.07	V	32.10	-31.17	66.00	-95.26	-29.26	-13	16.26
4 667.28	46.38	V	32.17	-30.01	48.54	-95.26	-46.72	-13	33.72
5 272.27	48.14	V	33.89	-29.19	52.84	-95.26	-42.42	-13	29.42
5 877.13	45.80	H	34.51	-28.37	51.94	-95.26	-43.32	-13	30.32
6 951.39	48.88	V	35.60	-27.58	56.90	-95.26	-38.36	-13	25.36
7 556.38	41.64	V	36.00	-27.05	50.59	-95.26	-44.67	-13	31.67
8 161.21	40.42	V	36.40	-26.13	50.69	-95.26	-44.57	-13	31.57
8 630.68	45.98	V	36.60	-27.30	55.28	-95.26	-39.98	-13	26.98
Above 8 700.00	Not detected	-	-	-	-	-	-	-	-

ULCA_5A-66A

Frequency (MHz)	Measured Level (dB μ V)	Ant. Pol.	AF (dB/m)	AMP+CL (dB)	E (dB μ V/m)	CF (dB)	E.I.R.P. (dB m)	Limit (dB m)	Margin (dB)
PCC 10 MHz + SCC 20 MHz_ Low Channel (829.0 MHz + 1 720.0 MHz)									
3 360.13	48.71	H	31.00	-32.75	46.96	-95.26	-48.30	-13	35.30
3 360.12	52.40	V	31.00	-32.75	50.65	-95.26	-44.61	-13	31.61
4 246.75	45.18	H	32.10	-30.12	47.16	-95.26	-48.10	-13	35.10
4 246.62	53.02	V	32.10	-30.11	55.01	-95.26	-40.25	-13	27.25
Above 4 300.00	Not detected	-	-	-	-	-	-	-	-
PCC 10 MHz + SCC 20 MHz_ Middle Channel (836.5 MHz + 1 745.0 MHz)									
3 400.25	48.88	H	31.00	-32.15	47.73	-95.26	-47.54	-13	34.54
3 400.36	53.71	V	31.00	-32.15	52.56	-95.26	-42.70	-13	29.70
4 304.37	54.52	H	32.10	-30.63	55.99	-95.26	-39.28	-13	26.28
4 304.65	52.53	V	32.10	-30.63	54.00	-95.26	-41.26	-13	28.26
Above 4 400.00	Not detected	-	-	-	-	-	-	-	-
PCC 10 MHz + SCC 20 MHz_ High Channel (844.0 MHz + 1 770.0 MHz)									
3 440.39	52.19	H	31.00	-31.91	51.28	-95.26	-43.98	-13	30.98
3 440.28	54.42	V	31.00	-31.91	53.51	-95.26	-41.75	-13	28.75
4 361.73	55.86	H	32.10	-30.17	57.79	-95.26	-37.47	-13	24.47
4 361.47	55.83	V	32.10	-30.19	57.74	-95.26	-37.52	-13	24.52
Above 4 400.00	Not detected	-	-	-	-	-	-	-	-

ULCA_25A-26A

Frequency (MHz)	Measured Level (dB μ V)	Ant. Pol.	AF (dB/m)	AMP+CL (dB)	E (dB μ V/m)	CF (dB)	E.I.R.P. (dB m)	Limit (dB m)	Margin (dB)
PCC 20 MHz + SCC 10 MHz_ Low Channel (1 860.0 MHz + 829.0 MHz)									
3 080.28	60.35	V	30.16	-32.74	57.77	-95.26	-37.49	-13	24.49
3 518.26	76.05	H	31.14	-32.51	74.68	-95.26	-20.58	-13	7.58
3 518.52	67.72	V	31.14	-32.51	66.35	-95.26	-28.91	-13	15.91
4 124.00	58.54	H	32.10	-29.35	61.29	-95.26	-33.97	-13	20.97
4 124.34	65.39	V	32.10	-29.36	68.13	-95.26	-27.13	-13	14.13
4 562.61	52.12	H	32.00	-29.98	54.14	-95.26	-41.13	-13	28.13
4 562.69	53.00	V	32.00	-29.98	55.02	-95.26	-40.24	-13	27.24
5 168.34	48.66	H	33.64	-29.36	52.94	-95.26	-42.33	-13	29.33
5 168.28	53.93	V	33.64	-29.36	58.21	-95.26	-37.05	-13	24.05
6 212.65	45.72	V	34.80	-27.38	53.14	-95.26	-42.12	-13	29.12
6 818.12	50.43	V	35.44	-27.22	58.65	-95.26	-36.61	-13	23.61
Above 6 900.00	Not detected	-	-	-	-	-	-	-	-
PCC 20 MHz + SCC 10 MHz_ Middle Channel (1 882.5 MHz + 836.5 MHz)									
3 057.65	58.99	V	30.12	-31.75	57.36	-95.26	-37.90	-13	24.90
3 540.94	74.73	H	31.18	-32.54	73.37	-95.26	-21.89	-13	8.89
3 541.13	64.58	V	31.18	-32.55	63.21	-95.26	-32.05	-13	19.05
4 124.23	58.61	H	32.10	-29.36	61.35	-95.26	-33.91	-13	20.91
4 124.06	65.09	V	32.10	-29.35	67.84	-95.26	-27.42	-13	14.42
4 607.93	49.74	H	32.02	-29.83	51.93	-95.26	-43.33	-13	30.33
4 607.74	49.68	V	32.02	-29.84	51.86	-95.26	-43.40	-13	30.40
5 190.87	47.14	H	33.68	-29.67	51.15	-95.26	-44.12	-13	31.12
5 190.72	51.32	V	33.68	-29.67	55.33	-95.26	-39.93	-13	26.93
6 257.28	43.94	V	34.80	-28.35	50.39	-95.26	-44.87	-13	31.87
6 840.07	48.06	V	35.48	-27.79	55.75	-95.26	-39.52	-13	26.52
Above 6 900.00	Not detected	-	-	-	-	-	-	-	-

Frequency (MHz)	Measured Level (dB μ V)	Ant. Pol.	AF (dB/m)	AMP+CL (dB)	E (dB μ V/m)	CF (dB)	E.I.R.P. (dB m)	Limit (dB m)	Margin (dB)
PCC 20 MHz + SCC 10 MHz_ High Channel (1 905.0 MHz + 844.0 MHz)									
3 034.80	56.32	V	30.10	-32.44	53.98	-95.26	-41.28	-13	28.28
3 563.74	70.79	H	31.25	-32.04	70.00	-95.26	-25.26	-13	12.26
3 563.66	62.81	V	31.25	-32.05	62.01	-95.26	-33.25	-13	20.25
4 124.11	56.70	H	32.10	-29.35	59.45	-95.26	-35.81	-13	22.81
4 124.06	64.28	V	32.10	-29.35	67.03	-95.26	-28.23	-13	15.23
4 652.86	50.56	H	32.11	-30.13	52.54	-95.26	-42.72	-13	29.72
4 652.80	49.55	V	32.11	-30.13	51.53	-95.26	-43.73	-13	30.73
5 213.24	44.80	H	33.73	-30.04	48.49	-95.26	-46.77	-13	33.77
5 213.36	51.28	V	33.73	-30.04	54.97	-95.26	-40.29	-13	27.29
6 302.34	42.04	V	34.80	-27.71	49.13	-95.26	-46.13	-13	33.13
6 863.05	48.84	V	35.50	-27.80	56.54	-95.26	-38.73	-13	25.73
Above 6 900.00	Not detected	-	-	-	-	-	-	-	-

Remark;

1. AF = Antenna Factor, CL = Cable Loss, CF = Conversion Factor.
2. E (dB μ V/m) = Measured Level (dB μ V) + Antenna Factor (dB/m) + AMP (dB) + Cable Loss (dB).
3. E.I.R.P. (dB m) = E (dB μ V/m) + CF (dB).
4. E.R.P. (dB m) = E (dB μ V/m) + CF (dB) - 2.15 (dB); where E.R.P. and E.I.R.P. are expressed in consistent units.
5. CF (dB) = 20 log D - 104.8; where D is the measurement distance in meters, According to KDB 971168 D01 v03r01 5.8.4.
6. The frequency spectrum is examined from 9 kHz to the 10th harmonic of the fundamental frequency of the transmitter. No other spurious and harmonic emissions were reported greater than listed emissions above table.

3. Conducted Output Power

3.1. Limit

CFR 47, Section FCC §2.1046

3.2. Test Procedure

Output power shall be measured at the RF output terminals for all configurations.

1. The RF output of the transmitter was connected to the input of the mobile test unit in order to establish communication with the EUT.
2. The EUT was set up for the max. output power with pseudo random data modulation by using mobile test unit parameters.
3. The measurement performed using a wideband RF power meter.
4. This EUT was tested under all configurations and the highest power was investigated and reported.

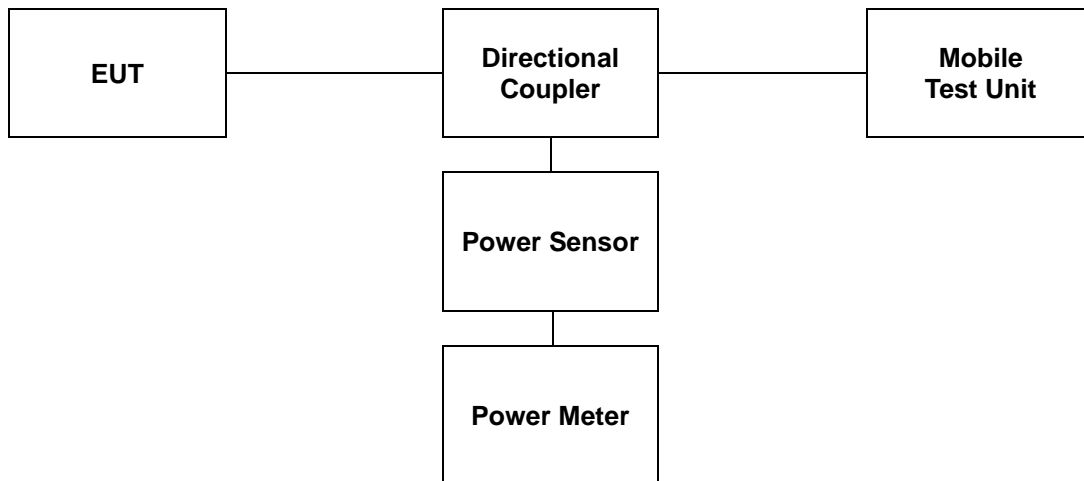

3.3. Test Result

Ambient temperature : (23 ± 1) °C
 Relative humidity : 47 % R.H.

ULCA 5B												
Ch.	PCC					SCC					Power	
	BW [MHz]	Freq. [MHz]	Ch.	RB	RB Offset	BW [MHz]	Freq. [MHz]	Ch.	RB	RB Offset	(dB m)	(W)
Low	3	825.6	20416	1	14	5	825.6	20455	1	0	23.05	0.202
	5	826.5	20425	1	24	3	830.4	20464	1	0	23.15	0.207
	5	826.8	20428	1	24	10	834.0	20500	1	0	23.12	0.205
	10	829.0	20450	1	49	5	836.2	20522	1	0	23.21	0.209
	10	829.0	20450	1	49	10	838.9	20549	1	0	23.16	0.207
Middle	3	834.1	20501	1	14	5	838.0	20540	1	0	23.11	0.205
	5	835.0	20510	1	24	3	838.9	20549	1	0	23.14	0.206
	5	831.8	20478	1	24	10	839.0	20550	1	0	23.10	0.204
	10	834.0	20500	1	49	5	841.2	20572	1	0	23.17	0.207
	10	831.6	20476	1	49	10	841.5	20575	1	0	23.11	0.205
High	3	842.6	20586	1	14	5	846.5	20625	1	0	23.10	0.204
	5	843.5	20595	1	24	3	847.4	20634	1	0	23.05	0.202
	5	836.8	20528	1	24	10	844.0	20600	1	0	23.03	0.201
	10	839.0	20550	1	49	5	846.2	20622	1	0	23.09	0.204
	10	834.1	20501	1	49	10	844.0	20600	1	0	23.14	0.206

Note;

QPSK Modulation with 1 RB

ULCA 5B												
Ch.	PCC					SCC					Power	
	BW [MHz]	Freq. [MHz]	Ch.	RB	RB Offset	BW [MHz]	Freq. [MHz]	Ch.	RB	RB Offset	(dB m)	(W)
Low	3	825.6	20416	1	14	5	825.6	20455	1	0	22.68	0.185
	5	826.5	20425	1	24	3	830.4	20464	1	0	22.72	0.187
	5	826.8	20428	1	24	10	834.0	20500	1	0	22.62	0.183
	10	829.0	20450	1	49	5	836.2	20522	1	0	22.51	0.178
	10	829.0	20450	1	49	10	838.9	20549	1	0	22.45	0.176
Middle	3	834.1	20501	1	14	5	838.0	20540	1	0	22.69	0.186
	5	835.0	20510	1	24	3	838.9	20549	1	0	22.78	0.190
	5	831.8	20478	1	24	10	839.0	20550	1	0	22.68	0.185
	10	834.0	20500	1	49	5	841.2	20572	1	0	22.69	0.186
	10	831.6	20476	1	49	10	841.5	20575	1	0	22.92	0.196
High	3	842.6	20586	1	14	5	846.5	20625	1	0	22.57	0.181
	5	843.5	20595	1	24	3	847.4	20634	1	0	22.65	0.184
	5	836.8	20528	1	24	10	844.0	20600	1	0	22.46	0.176
	10	839.0	20550	1	49	5	846.2	20622	1	0	22.79	0.190
	10	834.1	20501	1	49	10	844.0	20600	1	0	22.51	0.178

Note;

16QAM Modulation with 1 RB

ULCA 5B												
Ch.	PCC					SCC					Power	
	BW [MHz]	Freq. [MHz]	Ch.	RB	RB Offset	BW [MHz]	Freq. [MHz]	Ch.	RB	RB Offset	(dB m)	(W)
Low	3	825.6	20416	15	0	5	825.6	20455	25	0	21.85	0.153
	5	826.5	20425	25	0	3	830.4	20464	15	0	22.41	0.174
	5	826.8	20428	25	0	10	834.0	20500	50	0	22.30	0.170
	10	829.0	20450	50	0	5	836.2	20522	25	0	22.35	0.172
	10	829.0	20450	50	0	10	838.9	20549	50	0	22.35	0.172
Middle	3	834.1	20501	15	0	5	838.0	20540	25	0	22.25	0.168
	5	835.0	20510	25	0	3	838.9	20549	15	0	22.40	0.174
	5	831.8	20478	25	0	10	839.0	20550	50	0	22.07	0.161
	10	834.0	20500	50	0	5	841.2	20572	25	0	22.51	0.178
	10	831.6	20476	50	0	10	841.5	20575	50	0	22.40	0.174
High	3	842.6	20586	15	0	5	846.5	20625	25	0	22.20	0.166
	5	843.5	20595	25	0	3	847.4	20634	15	0	22.09	0.162
	5	836.8	20528	25	0	10	844.0	20600	50	0	22.25	0.168
	10	839.0	20550	50	0	5	846.2	20622	25	0	22.08	0.161
	10	834.1	20501	50	0	10	844.0	20600	50	0	22.45	0.176

Note;

QPSK Modulation with Full RB

ULCA 5B												
Ch.	PCC					SCC					Power	
	BW [MHz]	Freq. [MHz]	Ch.	RB	RB Offset	BW [MHz]	Freq. [MHz]	Ch.	RB	RB Offset	(dB m)	(W)
Low	3	825.6	20416	15	0	5	825.6	20455	25	0	21.12	0.129
	5	826.5	20425	25	0	3	830.4	20464	15	0	21.73	0.149
	5	826.8	20428	25	0	10	834.0	20500	50	0	21.54	0.143
	10	829.0	20450	50	0	5	836.2	20522	25	0	21.72	0.149
	10	829.0	20450	50	0	10	838.9	20549	50	0	21.60	0.145
Middle	3	834.1	20501	15	0	5	838.0	20540	25	0	21.56	0.143
	5	835.0	20510	25	0	3	838.9	20549	15	0	21.81	0.152
	5	831.8	20478	25	0	10	839.0	20550	50	0	21.72	0.149
	10	834.0	20500	50	0	5	841.2	20572	25	0	21.96	0.157
	10	831.6	20476	50	0	10	841.5	20575	50	0	21.92	0.156
High	3	842.6	20586	15	0	5	846.5	20625	25	0	21.53	0.142
	5	843.5	20595	25	0	3	847.4	20634	15	0	21.81	0.152
	5	836.8	20528	25	0	10	844.0	20600	50	0	21.72	0.149
	10	839.0	20550	50	0	5	846.2	20622	25	0	21.89	0.155
	10	834.1	20501	50	0	10	844.0	20600	50	0	21.73	0.149

Note;

16QAM Modulation with Full RB

ULCA 7C												
Ch.	PCC					SCC					Power	
	BW [MHz]	Freq. [MHz]	Ch.	RB	RB Offset	BW [MHz]	Freq. [MHz]	Ch.	RB	RB Offset	(dB m)	(W)
Low	10	2 505.5	20805	1	49	20	2 519.9	20949	1	0	23.35	0.216
	20	2 510.0	20850	1	99	10	2 524.4	20994	1	0	23.02	0.200
	15	2 507.5	20825	1	74	15	2 522.5	20975	1	0	23.31	0.214
	15	2 507.5	20825	1	74	10	2 519.5	20945	1	0	23.45	0.221
	15	2 507.8	20828	1	74	20	2 524.9	20999	1	0	23.27	0.212
	20	2 510.0	20850	1	99	15	2 527.1	21021	1	0	23.34	0.216
	20	2 510.0	20850	1	99	20	2 529.8	21048	1	0	23.43	0.220
Middle	10	2 525.6	21006	1	49	20	2 540.0	21150	1	0	23.41	0.219
	20	2 530.1	21051	1	99	10	2 544.5	21195	1	0	23.52	0.225
	15	2 527.5	21025	1	74	15	2 542.5	21175	1	0	23.27	0.212
	15	2 530.1	21051	1	74	10	2 542.1	21171	1	0	23.36	0.217
	15	2 525.3	21003	1	74	20	2 542.4	21174	1	0	23.33	0.215
	20	2 527.6	21026	1	99	15	2 544.7	21197	1	0	23.21	0.209
	20	2 525.1	21001	1	99	20	2 544.9	21199	1	0	23.16	0.207
High	10	2 545.6	21206	1	49	20	2 560.0	21350	1	0	22.98	0.199
	20	2 550.1	21251	1	99	10	2 564.5	21395	1	0	22.86	0.193
	15	2 547.5	21225	1	74	15	2 562.5	21375	1	0	23.15	0.207
	15	2 552.7	21277	1	74	10	2 564.7	21397	1	0	23.05	0.202
	15	2 542.9	21179	1	74	20	2 560.0	21350	1	0	22.97	0.198
	20	2 545.1	21201	1	99	15	2 562.2	21372	1	0	23.07	0.203
	20	2 540.2	21152	1	99	20	2 560.0	21350	1	0	23.11	0.205

Note;

QPSK Modulation with 1 RB