



RT 1000

Deployment Guide

January 31, 2012

Part Number: 90-0004

R03.h



© 2010-2012 Wireless Seismic, Inc. All rights reserved.

All other brands, company names, product names, trademarks or service marks referenced in this material are the property of their respective owners, who may or may not be affiliated with, connected to, or sponsored by Wireless Seismic, Inc.

Wireless Seismic, Inc.'s trademarks, registered trademarks or trade dress may not be used in connection with any product or service that is not the property of Wireless Seismic, Inc., in any manner that is likely to cause confusion among customers, or in any manner that disparages or discredits Wireless Seismic, Inc. The products and services described in this material may not be available in all regions.

All information supplied in this Deployment Guide regarding weights, sizes, performance, functionality and other technical information of any kind is approximate and shall be taken as generally representing our products. We may modify our products, discontinue products or add new products at any time and without providing an update to this Deployment Guide.

NOTHING CONTAINED IN THIS DEPLOYMENT GUIDE SHALL BE CONSIDERED A REPRESENTATION OR WARRANTY MADE BY WIRELESS SEISMIC, INC. ("WIRELESS SEISMIC") CONCERNING ANY PRODUCT DESCRIBED HEREIN, OR OTHERWISE. EXCEPT FOR THE WARRANTIES THAT MAY BE PROVIDED IN A SEPARATE AGREEMENT BETWEEN YOU AND WIRELESS SEISMIC, WIRELESS SEISMIC MAKES NO REPRESENTATION OR WARRANTY OF ANY KIND AND NO WARRANTY, CONDITION OR REPRESENTATION, WHETHER EXPRESS, IMPLIED, ORAL OR STATUTORY, IS PROVIDED TO YOU OR ANY THIRD PARTY. WITHOUT LIMITING THE FOREGOING, WIRELESS SEISMIC EXPRESSLY EXCLUDES AND DISCLAIMS ANY WARRANTY, CONDITION OR REPRESENTATION: (1) OF MERCHANTABILITY, FITNESS FOR A PARTICULAR PURPOSE, TITLE, SATISFACTORY QUALITY, OR ARISING FROM A COURSE OF DEALING, USAGE, OR TRADE PRACTICE; (2) THAT ANY PRODUCTS (INCLUDING SOFTWARE) WILL BE FREE FROM INFRINGEMENT OR VIOLATION OF ANY RIGHTS, INCLUDING INTELLECTUAL PROPERTY RIGHTS, OF THIRD PARTIES; OR (3) THAT THE OPERATION OF ANY PRODUCT (INCLUDING SOFTWARE) WILL BE UNINTERRUPTED OR ERROR FREE. THIS DISCLAIMER AND EXCLUSION SHALL APPLY EVEN IF THE EXPRESS WARRANTIES HEREIN FAIL OF THEIR ESSENTIAL PURPOSE.

To order additional copies of this document, send an email to your sales representative requesting the following:

- ◆ Part Number: 90-0004-PDF
 - ◆ Part Number: 90-0004-Paper
-



Table of Contents

1. Overview	9
1.1 About this Guide	9
1.2 Who Should Use this Guide	9
1.3 Related Documents	9
1.4 Getting Help	9
2. Layout	11
2.1 Prerequisites	11
2.2 Getting Ready	11
2.3 Preparing the Equipment	13
2.4 Setting Up the Central Recording System	13
2.4.1 Setting up the Computer	13
2.4.2 Connecting to the Source Controller	13
2.4.3 Source Interface Cables	20
2.4.4 Trigger Pin-Outs	22
2.5 Laying Out the Equipment	25
2.5.1 Prerequisites	25
2.5.2 Assembling the Ground Equipment	26
2.5.3 Placing the WRU in the Field	28
2.5.4 Placing the BSU in the Field	30
3. Backhaul	31
3.1 Overview	31
3.2 Backhaul Components	35
3.2.1 BSU Components	35
3.2.1.1 BSU	35
3.2.1.2 PoE Switch Unit	36
3.2.1.3 Battery and Power Supply	37
3.2.1.4 Cables	38
3.2.2 Antennas	39
3.2.3 Radio Kit Components	39
3.2.3.1 FM1100 Radio	40
3.2.3.2 FM3100 Radio	41
3.2.4 Mast Kit Components	41
3.2.4.1 Mast	42
3.2.4.2 Base	42
3.2.4.3 Bag	45
3.2.4.4 Backpack Kit	45

3.3	Configure the Radios	46
3.3.1	Create a Private Network.	46
3.3.2	Setting NIC Priority.	54
3.3.3	Configure the Radio	56
3.3.4	Restore your Network Settings.	59
3.3.5	Using the Fluidmesh Interface to Scan	59
3.3.6	Using the Fluidmesh Interface to Ping	59
3.4	Setting up the Backhaul Equipment	59
3.5	Installing Two Radios on the Mast	63
3.6	Removing the Backhaul Equipment	64
3.7	Use Cases or Example Deployments	64
4.	Demobilization	68
4.1	Overview	68
4.2	Removing the WRU from the Field.	68
4.3	Disassemble the WRU	69
5.	Maintaining the Equipment	71
5.1	Units	71
5.2	Antennas	71
5.3	Geophones	71
5.4	Cautions.	72
6.	Troubleshooting and Tips	73
6.1	Best Practices	73
6.1.1	24 Ah Batteries	73
6.1.2	PoE	73
6.1.3	Urban Environments	73
6.1.4	Ethernet Cables	74
6.1.5	Antennas	74
6.2	Troubleshooting	74
6.2.1	Fluidmesh Radios	74
7.	Batteries	75
7.1	Lithium Ion Batteries	75
7.1.1	Specifications.	75
7.1.2	Handling and Safety Guidelines	76
7.1.3	Transportation	77
7.1.4	Storage.	78
7.2	Charging Lithium Ion Batteries	79
7.2.1	Charging Precautions	79
7.2.2	Battery Charger	80
7.3	BSU Battery	81
8.	Batteries	82
8.1	Batteries au lithium-ion	82
8.1.1	Spécifications.	82
8.1.2	Directives en matière de manipulation et de sécurité	83
8.1.3	Transport	84

8.1.4 Entreposage	86
8.2 Chargement des batteries au lithium-ion.	87
8.2.1 Précautions de chargement.	87
8.2.2 Chargeur de batterie	87
8.3 BSU de batterie	89
A. Legal Information	90
A.1 FCC Rules and Regulations Compliance.	90
A.2 Industry Canada Compliance	91
B. L'information juridique	92
B.1 Conformité avec les règles et règlements de la FCC	92
B.2 Industrie Canada Conformité.	93
C. Fluidmesh Radio Specifications	94
C.1 The Fluidmesh Mito Series.	94
C.2 Fluidmesh 1100 with MITO Technology	96
C.3 Fluidmesh 3100 with MITO Technology	97
C.4 MITO Series General Characteristics.	98
D. LED Indicators	100
E. Weighted Mast	106
E.1 Specifications.	106
E.2 Hardware Supplied	107
E.3 Assembly Instructions.	108
Index	109

List of Figures

Figure 2–1	Pelton Vib Pro Interface Card in Slot	15
Figure 2–2	Pelton Vib Pro Interface Card	15
Figure 2–3	Pelton Vib Pro Interface Card Assembly Drawing	16
Figure 2–4	Pelton Vib Pro Jumpers	17
Figure 2–5	Pelton Analog Output Connection	18
Figure 2–6	BSU Analog Input Connection	18
Figure 2–7	Pelton Vib Pro TimeBrk Act	19
Figure 2–8	Pelton Vib Pro StartDelay	20
Figure 2–9	PELTON SOURCE CONTROL (60-0015) Cable	21
Figure 2–10	WRU	25
Figure 2–11	BSU	25
Figure 2–12	Geophone	25
Figure 2–13	Battery Latch	27
Figure 2–14	Installing the Battery	27
Figure 2–15	Installing the Geophone	28
Figure 2–16	Installing the Antenna	28
Figure 2–17	Power on the Unit	29
Figure 2–18	Place the Unit	29
Figure 3–1	Possible LTU Components	32
Figure 3–2	Central Recording Truck Components	33
Figure 3–3	Single Backhaul Data Direction	34
Figure 3–4	Backhaul Components Packed for Transport	35
Figure 3–5	Base Station Unit (BSU)	36
Figure 3–6	PoE	37
Figure 3–7	Protective Battery Case	38
Figure 3–8	Protective Ethernet Connector	38
Figure 3–9	Channel Color Example	40
Figure 3–10	FM1100 Radio	40
Figure 3–11	FM3100 Radio	41
Figure 3–12	Mast (55-0008)	42
Figure 3–13	Base (55-0007)	43
Figure 3–14	Assembled Backhaul Mast	44
Figure 3–15	Base (70-0070)	45
Figure 3–16	Fluidmesh Radio Private Network	47
Figure 3–17	Control Panel, Network and Internet	48
Figure 3–18	Control Panel, Network and Sharing Center	49
Figure 3–19	Control Panel, Change Adapter Settings	50
Figure 3–20	Control Panel, LAN Properties	51
Figure 3–21	Control Panel, Networking Properties	52
Figure 3–22	Control Panel, IP Address	53
Figure 3–23	Advanced Network Settings Menu	55
Figure 3–24	LAN Hierarchy	55
Figure 3–25	Radio Login Window	56
Figure 3–26	Radio Home Window, Mesh End	57
Figure 3–27	Fluidmesh MeshWizard Interface	58
Figure 3–28	Mast on a Slope	60
Figure 3–29	Base and Wind Orientation	61
Figure 3–30	Securing Lines to Large Cleat	62
Figure 3–31	Backhaul Antenna Erected	62

Figure 3–32	Two-Radio Installation.....	63
Figure 3–33	2D Single Backhaul.....	65
Figure 3–34	3D Dual Backhaul, Two Root Nodes.....	66
Figure 3–35	2D Single Backhaul, Star Configuration	67
Figure 4–1	Power Off the Unit	68
Figure 4–2	Undeployed Unit.....	69
Figure 4–3	Removing the Antenna.....	70
Figure 4–4	Removing the Geophone	70
Figure 4–5	Removing the Battery	70
Figure 7–1	Example Battery Shipping Label	78
Figure 7–2	Battery Charger	80
Figure 7–3	Serial Number Label and LED Indicator.....	81
Figure E–1	Weighted Mast	107
Figure E–2	Tripod Assembly – Front View	108

List of Tables

Table 2–1	PELTON SOURCE CONTROL (60-0015) Cable Pin List	20
Table 2–2	BSU DATA-POWER (60-0007) Cable Pin List.....	22
Table 2–3	SIU Source Control (60-0004) Cable Pin List.....	23
Table 2–4	BSU at Recording Truck (60-0012) Cable Pin List	24
Table 3–1	Base Station Unit Kit	35
Table 3–2	Antenna Specifications.....	39
Table 3–3	Radio Kit.....	39
Table 3–4	Mast Kit.....	41
Table 3–5	Fluidmesh Radio LEDs.....	47
Table 6–1	Troubleshooting Fluidmesh Radios.....	74
Table 7–1	Lithium Ion Battery Specifications	75
Table A–1	Antenna Specifications.....	90
Table D–1	WRU LED Status Indications	100
Table D–2	WRU LED Error Indications	102
Table D–3	BSU LED Discipline Indications.....	103

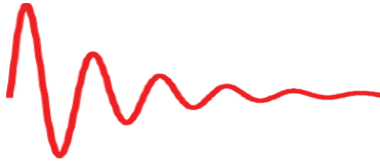

1.1 About this Guide

This document provides information on how to deploy the RT 1000 in the field.

1.2 Who Should Use this Guide

The expected users of this document are as follows:

- ◆ Crew (Layout/Troubleshooters)
- ◆ Technician (LTU)
- ◆ Bosses (Line Crew)

1.3 Related Documents

RT 1000-related documents are as follows:

- ◆ **“RT 1000 Documents Guide” (90-0001)** – Lists all of the RT 1000 documents with a brief description of each.
- ◆ **“RT 1000 Glossary” (90-0012)** – Lists and defines RT 1000 terms and acronyms. Includes some general seismic and geologic terms and acronyms.
- ◆ **Installation Guide (90-0003)** – TBD

1.4 Getting Help

To get help on the RT 1000 Central Recording System, consult the online help. You can find the help documents by clicking the help icon in the user interface, or by navigating to the following directory:

```
C:\wsi\rt1000\vx.y\server\help\index.htm
```

Where vx.y is the version number (for example, v1.3).

To get help on the RT 1000 deployment, consult this document.

1. Overview

Getting Help

If you cannot find the answers you need, please contact Wireless Seismic, Inc. Customer Support at:

13100 Southwest Freeway, Suite 150
Sugar Land, TX 77478
(832) 532-5048

support@wirelesseismic.com

5Mbps Draft

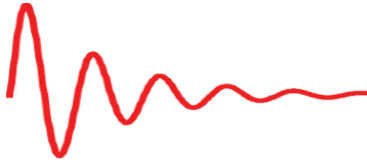

This chapter describes how to prepare (mobilization) and layout (install) the ground electronics.

2.1 Prerequisites

In preparation for mobilization, define the following:

- ◆ Survey
- ◆ Backhaul plan
- ◆ TBD

2.2 Getting Ready

Collect all of the following:

NOTE

Please refer to "Antenna Specifications" on page 90 for the list of supported antennas. Use of accessories other than those specified in this document is not supported or warranted.

- ◆ RT 1000 ground equipment (05-0002):
 - 1 Mbps WRUs (10-0001)
 - 5 Mbps WRUs (10-0017)

NOTE

You cannot mix 1Mbps WRUs and 5Mbps WRUs in the same spread. You must use all of the same type.

- LTUs (see "3. Backhaul" on page 31)

2. Layout

Getting Ready



NOTE

The LTU includes the Base Station Unit (BSU), the Power over Ethernet (PoE), the battery, the backhaul, and the mast.

- One of the following antennas:
 - ▶ 9 dBi antenna (65-0067)
 - ▶ 7 dBi antenna (6060-001-01)
 - ▶ 5 dBi antenna (65-0023)
 - ▶ 2 dBi antenna (65-0025)
- Geophones
- WRU Batteries (0400-001-01)
- WRU Dummy Batteries (55-0009)
- Battery Charging System (10-0008)
- Battery Charger Shelf (10-0011) (optional)
- Antenna Extenders
- Fiber Backhaul
- Tools
- Manuals
- Consumables
- Spares (15-0003)
 - ▶ Mast Parts
 - ▶ Base Parts
 - ▶ Guy Lines
 - ▶ Antennas
 - ▶ Batteries
 - ▶ Cables
 - ▶ Connectors



NOTE

The batteries (when fully discharged) require 8 hours of continuous charging in the battery charger connected to an AC source; therefore, the battery charger will be located at the staging area or in town.

- ◆ Non-RT 1000 ground equipment:
 - Recording truck:
 - ▶ Power source (diesel, benzene or other type of fueled generator)
 - ▶ Heating, cooling and ventilation system
 - ▶ Antenna masts for voice radio, Data telemetry, source control, and possibly satellite phone and/or internet

- ▶ Shock-mounted rack for PC, displays, servers, network devices, output devices, and so on
- ▶ Thermal plotter or equivalent
- ▶ Desk, chairs, small refrigerator, and coffeepot
- ▶ Computer, monitors, keyboard, mice, and so on
- ▶ External interfaces for installing and testing
- Safety equipment (vests, hard hats, and so on)
- Source controllers/Source Interface Unit (SIU)
- Any other third-party equipment
- Any other shot-related equipment
- Two-way radios

2.3 Preparing the Equipment

Ensure that the central recording system has the latest software available installed (see in the *RT 1000 Release Notes*).

Ensure that the ground equipment has the latest firmware available installed (see in the *RT 1000 Release Notes*).

Ensure that the industry standard best practices are followed for securing the equipment for transport.

2.4 Setting Up the Central Recording System

You can prepare the Central Recording System (CRS) hardware and software while the ground equipment is being placed in the field.

Set up the computer and peripheral equipment in the central recording system truck or trailer.

2.4.1 Setting up the Computer

Set up the CRS computer according to the instructions in the *RT 1000 Installation Guide*.

2.4.2 Connecting to the Source Controller

This section describes how to connect a source controller or Source Interface Unit (SIU) to the CRS. This release uses a Pelton Vib Pro™ source encoder/decoder.

See *“Central Recording Truck Components”* on page 33 for an illustration of the connected components.

You must configure the following items on the Pelton Vib Pro:

2. Layout

Setting Up the Central Recording System

- ◆ Interface card jumpers
 - Isolated remote start (J3, J4)
 - Negative-edge timebreak (J5, J6)
- ◆ Menu settings
 - **Start Delay** = 1000
 - **TimeBrk Act** = LOW
 - Make a note of the **VibratorID**. It must be entered as a parameter in the CSS. (MAIN MENU → 1. JOB PROFILE → 7. VibratorID)



NOTE

Detailed instructions on using the Pelton Vib Pro are beyond the scope of this document.

To connect and configure the Pelton Vib Pro:

- 1 Prerequisites:
 - The central recording system computer is installed
 - The CSS software is running
 - The Vib Pro is powered down
- 2 Open the back of the Vib Pro and remove the interface card. Use proper anti-static precautions. Refer to the Pelton documentation as necessary.

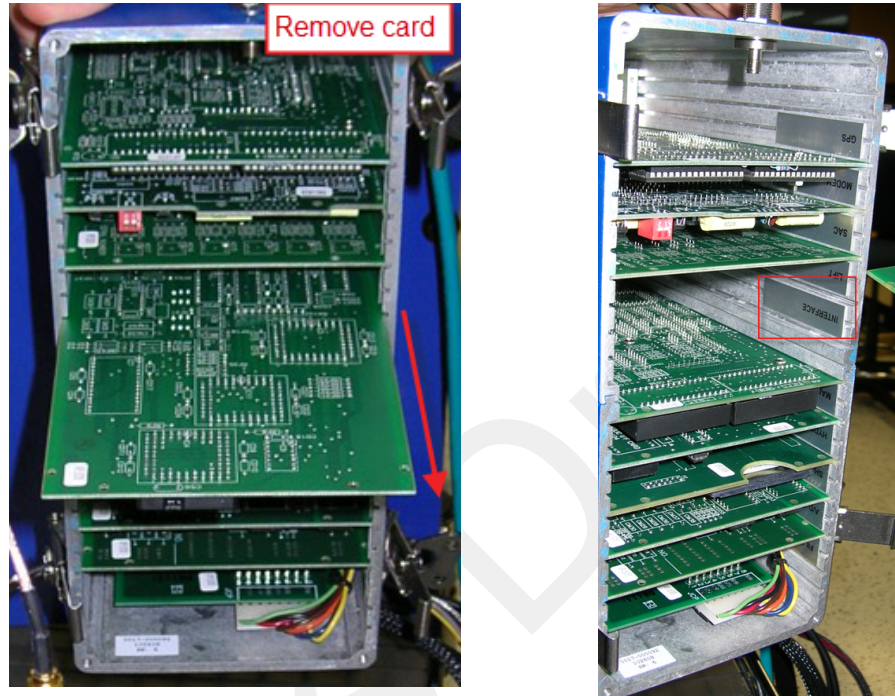

Figure 2–1 Pelton Vib Pro Interface Card in Slot

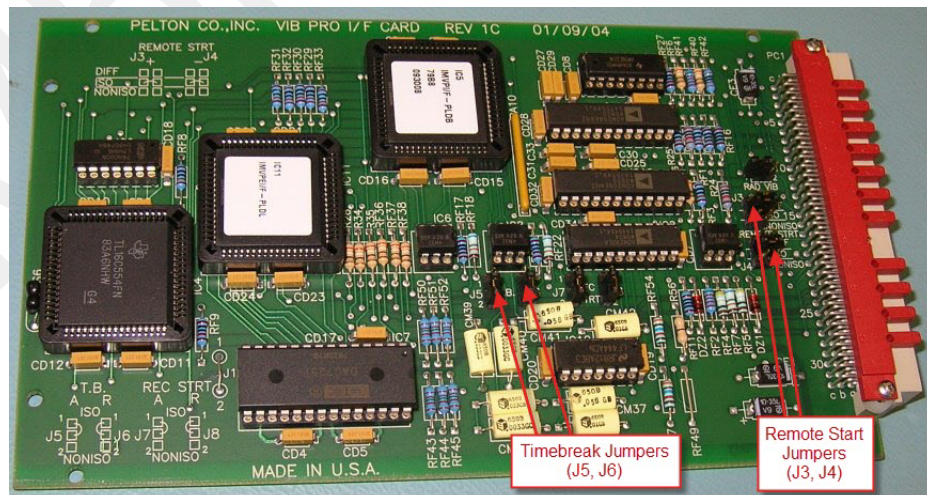

Figure 2–2 Pelton Vib Pro Interface Card

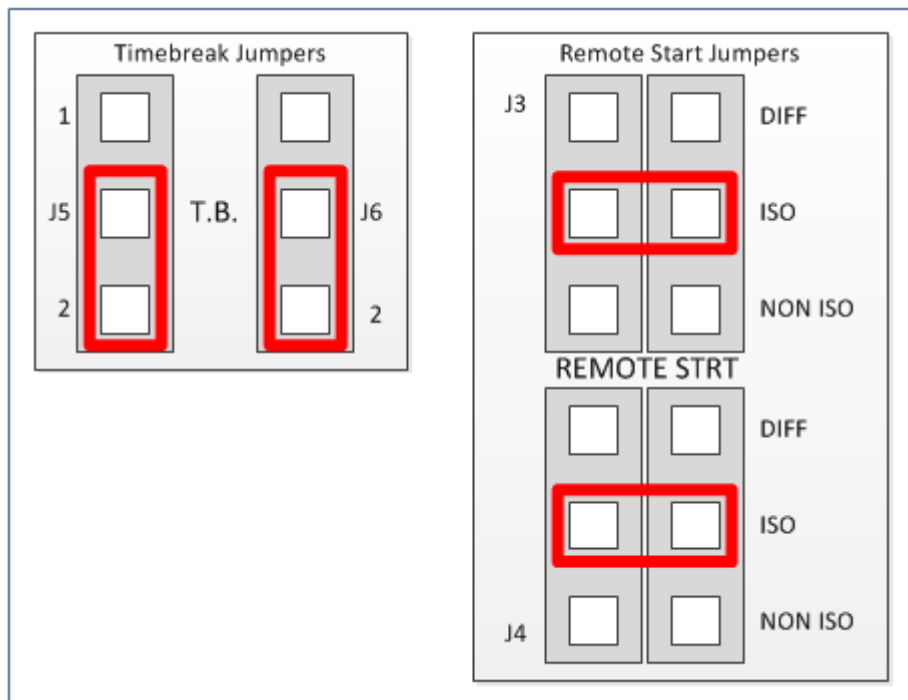

Figure 2–4 Pelton Vib Pro Jumpers

- 4 Slide the interface card into the Pelton Vib Pro and close the case.
- 5 Connect the Pelton analog output (JF: 27-pin connector) to the WRU's analog input (geophone connector) as shown in the following figures:

2. Layout

Setting Up the Central Recording System

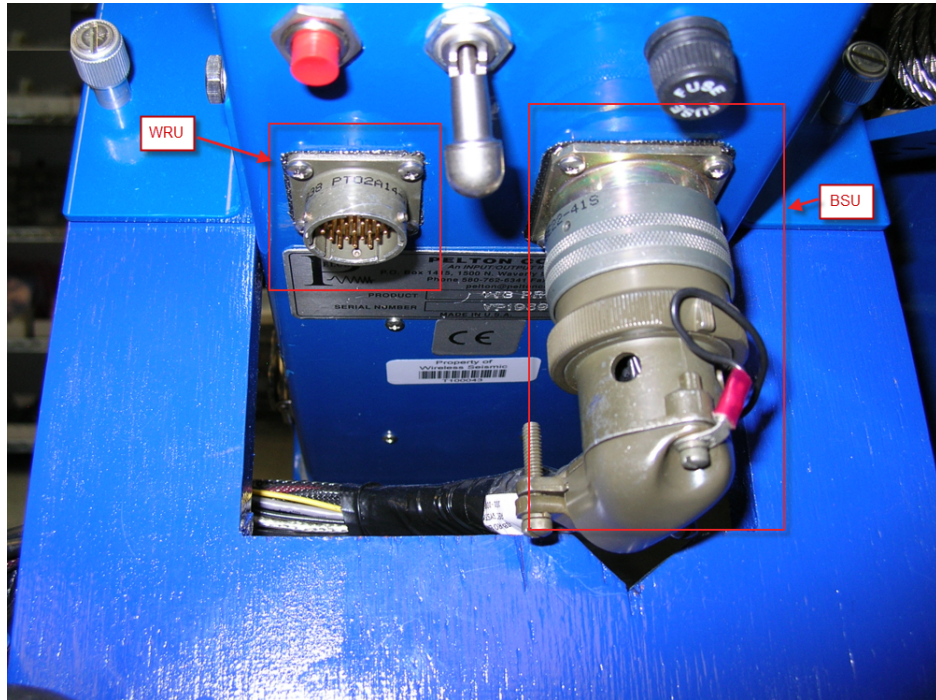

Figure 2-5 Pelton Analog Output Connection



Figure 2-6 BSU Analog Input Connection

- 6 Connect the Pelton Vib Pro JE Connector to the WRU analog input (geophone connector).
- 7 Power on the Pelton Vib Pro.
- 8 Set **TimeBrk Act=LOW**
(Start → Menu (B) → MORE → 15. HARDWARE SETUP → 1. TimeBrk Act : HIGH).

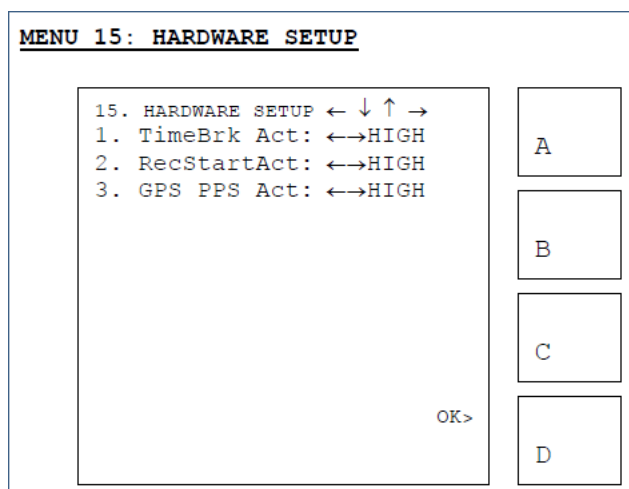

Figure 2–7 Pelton Vib Pro TimeBrk Act

- 9 Set the **Start Delay=1000**
(Start → Menu (B) → MORE → 10. RADIO → 11. StartDelay : 01000).

2. Layout

Setting Up the Central Recording System

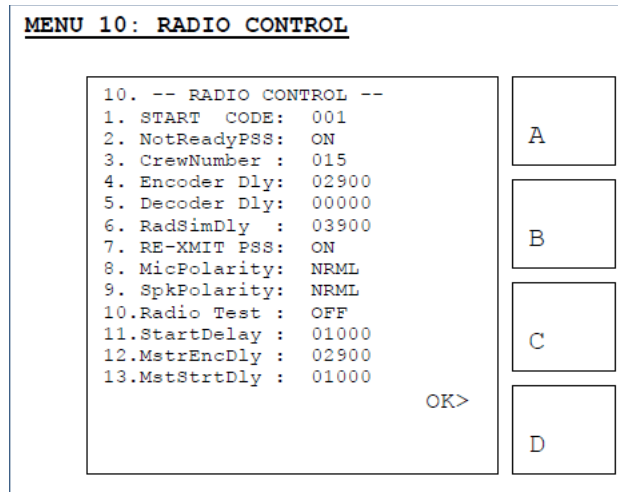

Figure 2–8 Pelton Vib Pro StartDelay

2.4.3 Source Interface Cables

The following table and figure show the cable used to connect the Pelton Vib Pro to the BSU and WRU.

Table 2–1 PELTON SOURCE CONTROL (60-0015) Cable Pin List

Signal Name	Wire Color	27-Pin Connector	RJ45 Plug	18-Pin Connector	2-Pin Connector
TX+	WHT/ORG * (WHT/GRN)	R	1	—	—
TX-	ORG * (GRN)	P	2	—	—
RX+	WHT/GRN * (WHT/ORG)	N	3	—	—
RX-	GRN * (ORG)	M	6	—	—
5V EXTERNAL NON ISO START	BLU	B	—	J	—
EXTERNAL START RETURN	GRN	A	—	K	—
5V TRIGGER IN 1	BRN	K	—	G	—
TRIGGER 1 RETURN	WHT	X	—	H	—

Table 2–1 PELTON SOURCE CONTROL (60-0015) Cable Pin List (cont.)

Signal Name	Wire Color	27-Pin Connector	RJ45 Plug	18-Pin Connector	2-Pin Connector
PWR	WHT/BLU (WHT/BLU)	b	5	—	—
PWR	BLU (BLU)	c	4	—	—
GND	WHT/BRN (WHT/BRN)	a	7	—	—
GND	BRN (BRN)	d	8	—	—
INPUT +	RED	—	—	—	N
INPUT -	BLU	—	—	—	U or A

WHT = White, ORG = Orange, GRN = Green, BLU = Blue, BRN = Brown, BLK = Black, YEL = Yellow

* Connect per Pin Numbers

Wire colors in parenthesis are for Ethernet cable wired per T-586A standard.

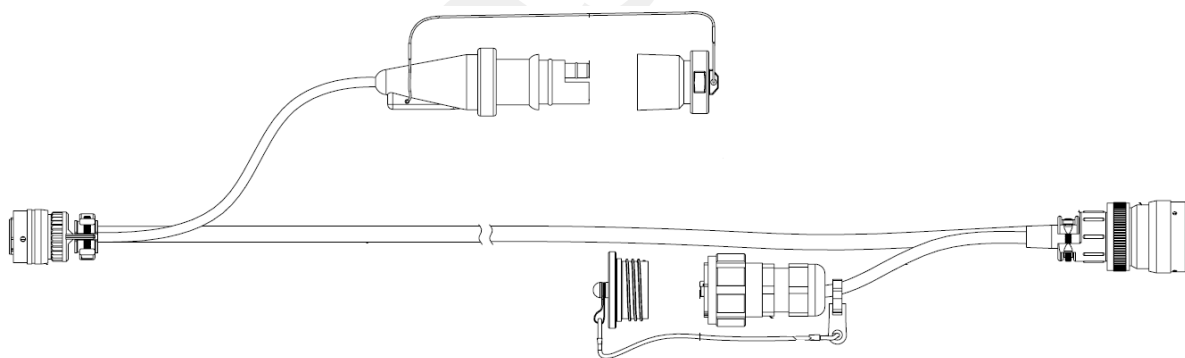

Figure 2–9 PELTON SOURCE CONTROL (60-0015) Cable

2. Layout

Setting Up the Central Recording System

2.4.4 Trigger Pin-Outs

The following tables show the signals on each pin for the three possible cables used to connect a trigger to the CSS computer:

Table 2–2 BSU DATA-POWER (60-0007) Cable Pin List

Signal Name	Wire Color	27-Pin Connector	Twisted Pair
TX+	WHT/ORG * (WHT/GRN)	R	Twisted Pair
TX-	ORG * (GRN)	P	
RX+	WHT/GRN * (WHT/ORG)	N	Twisted Pair
RX-	GRN * (ORG)	M	
5V EXTERNAL NON ISO START	RED	B	Twisted Pair
EXTERNAL START RETURN	BLK	A	
EXT START ISO OUT	BLU	E	Twisted Pair
EXT START ISO RETURN	BLK	U	
5V TRIGGER IN 1	RED	K	Twisted Pair
TRIGGER 1 RETURN	WHT	X	
PWR	RED	b	
PWR	RED	c	
GND	BLK	a	
GND	BLK	d	

WHT = White, ORG = Orange, GRN = Green, BLU = Blue, BRN = Brown, BLK= Black, YEL = Yellow

* Connect per Pin Numbers

Wire colors in parenthesis are for Ethernet cable wired per T-586A standard.

The following cable (60-0004) has not yet been implemented.

Table 2–3 SIU Source Control (60-0004) Cable Pin List

Signal Name	Wire Color	27-Pin Connector
5V0 EXTERNAL START	RED	B
EXT. START RETURN	BLK	A
RS232 TX OUT	WHT	C
RX/TX RETURNS	BLK	S
RS232 RX IN	GRN	D
RX/TX RETURNS	BLK	T
EXT START ISO OUT	BLU	E
EXT START ISO RETURN	BLK	U
GND DIG (JUMPTRACK NO)	YEL	F
GND DIG (JUMPTRACK NO)	BLK	G
5V0 TRIGGER IN 3	BRN	H
TRIGGER RETURN	BLK	V
5V0 TRIGGER IN 2	ORG	J
TRIGGER RETURN	BLK	W
5V0 TRIGGER IN 1	RED	K
TRIGGER RETURN	WHT	X
—	—	L
TX+	WHT/ORG* (WHT/GRN)	R
TXN	ORG* (GRN/WHT)	P
RX+	WHT/GRN* (WHT/ORG)	N
RXY	GRN* (ORG/WHT)	M
—	—	Y
—	—	Z
PWR	RED	c
PWR	RED	b

2. Layout

Setting Up the Central Recording System

Table 2–3 SIU Source Control (60-0004) Cable Pin List (cont.)

Signal Name	Wire Color	27-Pin Connector
GND	BLK	a
GND	BLK	d

WHT = White, ORG = Orange, GRN = Green, BLU = Blue, BRN = Brown, BLK = Black, YEL = Yellow
 * Connect per Pin Numbers
 Wire colors in parenthesis are for Ethernet cable wired per T-586A standard.

The following cable (60-0012) has not yet been implemented.

Table 2–4 BSU at Recording Truck (60-0012) Cable Pin List

Signal Name	Wire Color	27-Pin Connector
TX+	WHT/ORG * (WHT/GRN)	R
TX-	ORG * (GRN/WHT)	P
RX+	WHT/GRN * (WHT/ORG)	N
RX-	GRN * (ORG/WHT)	M
PWR	WHT/BLU (WHT/BLU)	b
PWR	BLU (BLU)	c
GND	WHT/BRN (WHT/BRN)	a
GND	BRN (BRN)	d
Free Leads		
5V EXTERNAL NON ISO START	BLU	B
RETURN EXTERNAL NON ISO START	GRN	A
5V TRIGGER IN 1	BRN	K
TRIGGER 1 RETURN	WHT	X

Table 2–4 BSU at Recording Truck (60-0012) Cable Pin List (cont.)

Signal Name	Wire Color	27-Pin Connector
WHT = White, ORG = Orange, GRN = Green, BLU = Blue, BRN = Brown, BLK= Black, YEL = Yellow		
* Connect per Pin Numbers		
Wire colors in parenthesis are for Ethernet cable wired per T-586A standard.		

2.5 Laying Out the Equipment

You can lay out the ground equipment while the central recording system hardware and software is being prepared.

The WRU is shown in the following figure:

Illustration TBD

Figure 2–10 WRU

The BSU is shown in the following figure:

Illustration TBD

Figure 2–11 BSU

An example geophone is shown in the following figure

Illustration TBD

Figure 2–12 Geophone

2.5.1 Prerequisites

You can attach the batteries, antennas, and geophones to the ground equipment prior to going into to the field, or as you place each unit. If you are assembling as you place the units, ensure that you have sufficient quantities for each unit, plus a few spares.

The RT 1000 shall be used with only the supplied antennas (*Table A–1 Antenna Specifications, on page 90*) attached to the WRU with an integrated type N male connector.

- ◆ The RT 1000 antennas shall be installed and handled by professionals specifically designated for this purpose.
- ◆ Changes or modifications not expressly approved by Wireless Seismic, Inc. can void the users’s authority to operate the equipment.

2. Layout

Laying Out the Equipment



WARNING

In order to comply with FCC radio frequency (RF) exposure requirements, the RT 1000 units must be installed so that a minimum separation distance of 20 cm is maintained between the antenna(s) and all persons at all times during normal operation.



WARNING AVERTISSE MENT

Afin de se conformer aux normes de la FCC en matière d'exposition aux radiofréquences (RF), les unités RT 1000 doivent être installées de manière à garder en permanence une distance minimale de 20 cm entre la ou les antennes et toute personne en mode de fonctionnement normal.

2.5.2 Assembling the Ground Equipment

This section describes the process to assemble the ground equipment prior to deployment.

To assemble the ground equipment:

- 1** Gather the equipment:
 - WRU or BSU
 - Antenna
 - Geophone
 - Batteries
- 2** Gather any special tools:
 - Optional: Nylon grip pliers
 - Optional: Loctite® 222
- 3** Attach one or more batteries to the WRU.
 - Press the battery into the connector.
 - Flip the bail over the molded area on the end of the battery.
 - Press the lever until the catch snaps to lock it in place.

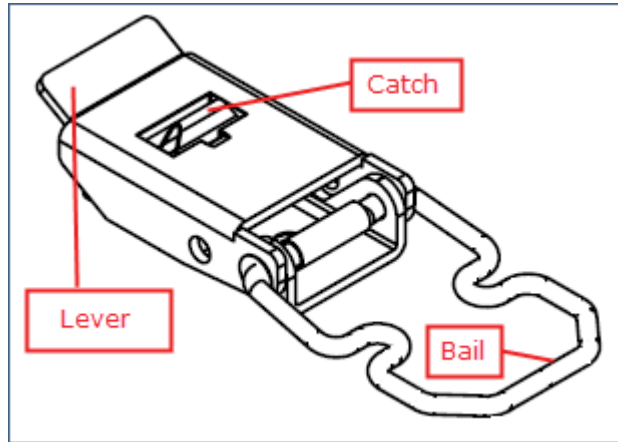

Figure 2–13 Battery Latch



Figure 2–14 Installing the Battery

- 4 Attach the geophone to the WRU.

2. Layout

Laying Out the Equipment



Figure 2–15 Installing the Geophone

- 5 Attach the antenna to the WRU or BSU. Ensure that the antenna connection is clean, and the antenna is snug and does not wobble.

TBD

Figure 2–16 Installing the Antenna



TIP

When determining which antenna to use (5 dBi, 7 dBi, 9dBi), consider the distance between WRUs, and how much vegetation is in the area.

For distances of 10 m to 30 m, use a 5 dBi antenna.

Distances of 30 m or greater, use a 7 dBi antenna.

For sudden elevation changes, such as cliffs, use a 2 dBi or 5 dBi antenna.

In special situations such as tall grass and dense vegetation, or distances of 55 m or greater, use a 9 dBi antenna.

2.5.3 Placing the WRU in the Field

This section describes the process to ready the ground equipment for interaction with the central recording system (deployment).

To deploy the WRU:

- 1 Prerequisites:
 - The WRU is assembled with battery, geophone, and antenna

 **NOTE**

If you are using a WRU as a Repeater, the deployment instructions are the same, except a geophone is not required. Repeaters are added to the line segment in the Spread Manager. See the RT 1000 Operator Guide for more information.

If a geophone is not connected, you can skip the geophone test. See "D. LED Indicators" on page 100 for more information on skipping the test and the relevant LED status indicators.

- 2 Pick up the WRU and point the geophone connector end towards the ground as shown in the following figure. After a few seconds, all of the LEDs illuminate:

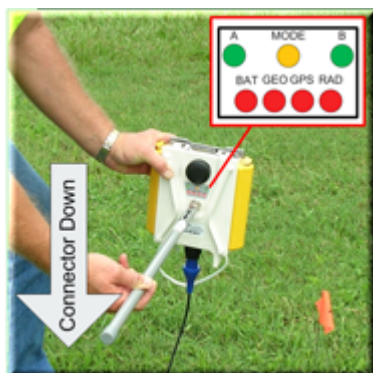

Figure 2–17 Power on the Unit

- 3 Place the unit flat on the ground as shown in the following figure:



Figure 2–18 Place the Unit

2. Layout

Laying Out the Equipment

- 4 The unit will begin a series of internal and external tests. The LEDs on the top of the unit indicate the current test and whether the unit passes or fails each test.



NOTE

See “D. LED Indicators” on page 100 for an explanation of the LED status and error conditions.

If a WRU self test fails, the WRU will continue to the next test.

You can skip a self-test by tipping the WRU geophone down and then returning it to the upright position (flat on the ground).

2.5.4 Placing the BSU in the Field

The BSU is part of the backhaul configuration. See “3. Backhaul” on page 31 for more information.



3.1 Overview

In network communications, the *backhaul* is the part of the network that contains the links and equipment between the core network and the sub networks.

Wireless mesh networking is a method where each radio node in the network captures and disseminates its own data as well as serves as a relay for other radio nodes in the network sending data along a path, *hopping* from one node to the next.

Power over Ethernet (PoE) is a technology that passes electrical power along an Ethernet cable. PoE is used where DC power is not available and USB unsuitable. Power can be supplied at the end of a network span or somewhere in the middle. PoE *switches* supply power at the end of a span. PoE *injectors* supply power somewhere between the PoE switch and the powered device. They inject power and do not affect the data.

The RT 1000 Central Recording System is a fully connected mesh network of Wireless Remote Units (WRUs) that communicate in a relay pattern (bucket-brigade or string-of-pearls) with a Line Tap Unit (LTU) on the 2.4 GHz Industrial, Scientific, and Medical (ISM) radio band.

The LTU is composed of the following:

- ◆ Base Station Unit (BSU)
- ◆ Power over Ethernet (PoE)

CAUTION

Ensure that the PoE box is placed on the ground, or that a grounding cable is attached to avoid causing damage to the internal electronics during use.

- ◆ 24 Ah DC Battery or Power Supply
- ◆ Cables
- ◆ Mast, mast base, and guy-wires
- ◆ 5.8 GHz backhaul radios
- ◆ Antennas

3. Backhaul

Overview

The LTU communicates by way of the BSU with the Central Software System (CSS) computer in the central recording truck along a backhaul on the 5.8 GHz ISM radio band. Some smaller systems may not require a backhaul.

The Central Software System (CSS) communicates with the field units via the backhaul radios. The backhaul radios act as access points for the BSUs.

The following figure illustrates the possible LTU components:

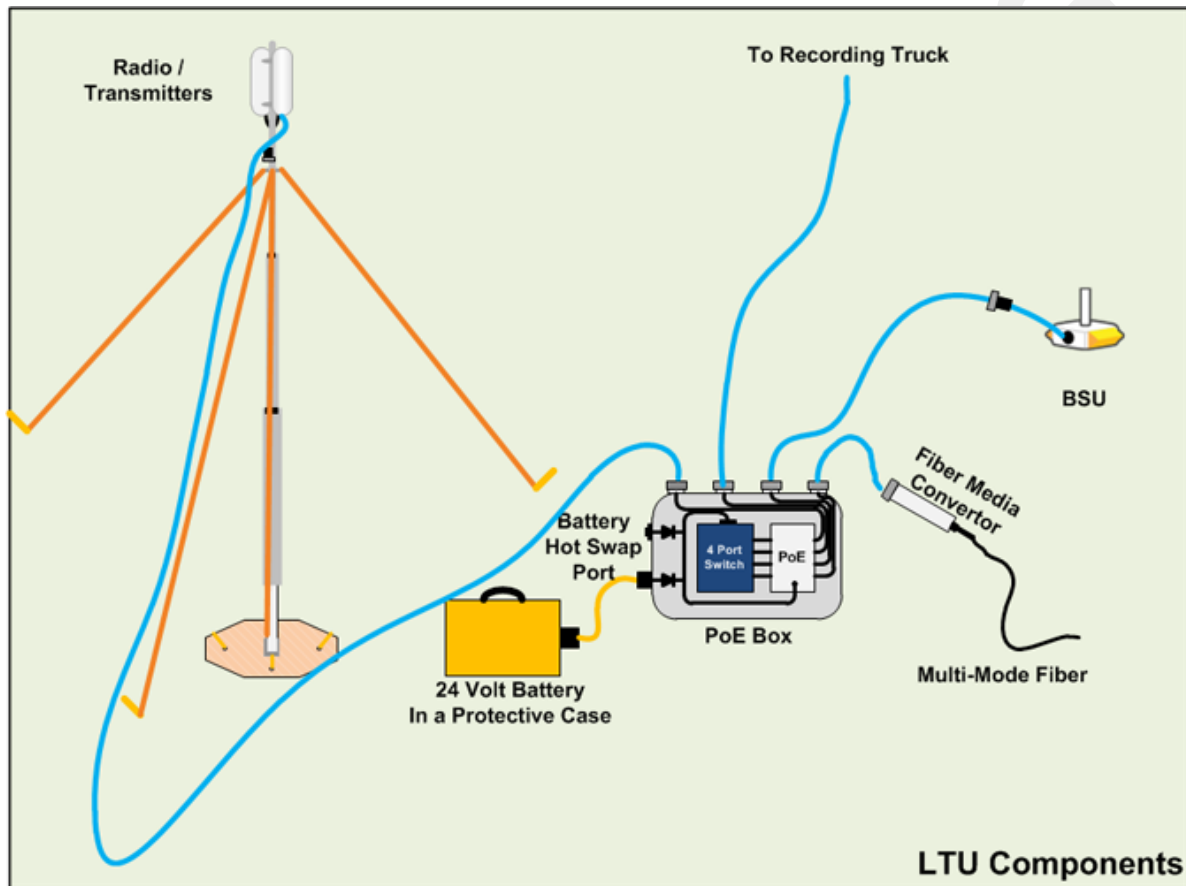

Figure 3–1 Possible LTU Components

The following figure illustrates the central recording truck components:

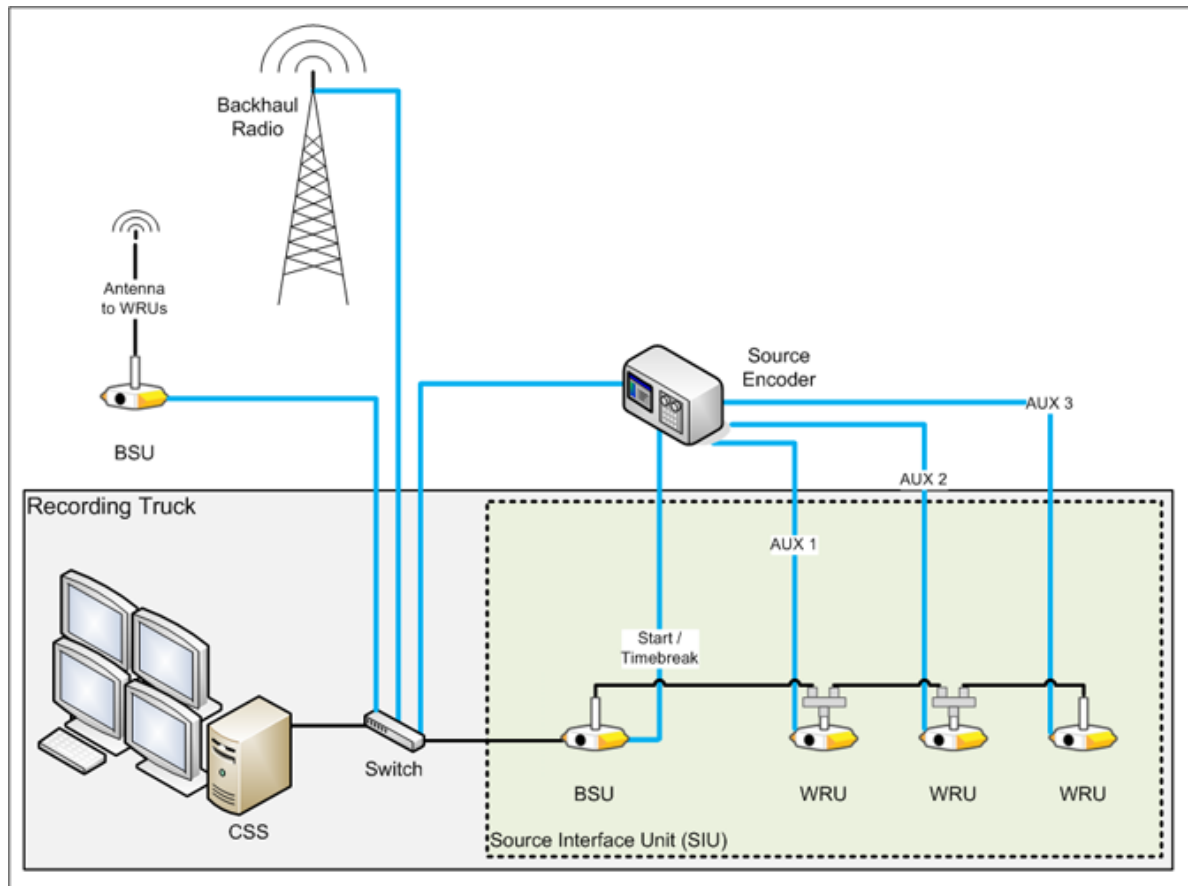

Figure 3–2 Central Recording Truck Components

NOTE

There can be from one to three WRUs in the Recording Truck as part of the SIU.

The following figure illustrates the components and data flow for a four-line, single-backhaul line with two root nodes example:

3. Backhaul

Overview

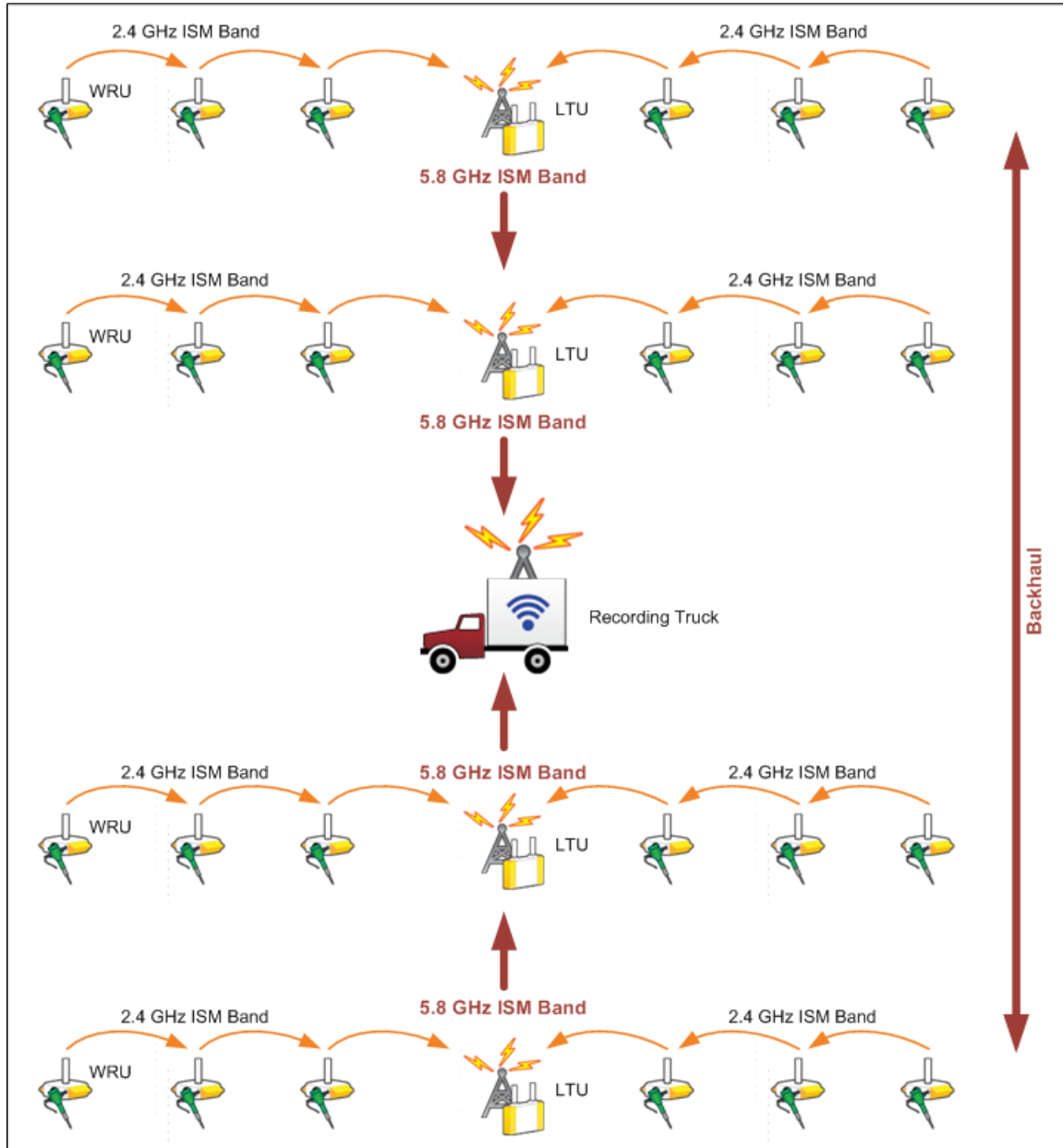

Figure 3–3 Single Backhaul Data Direction

3.2 Backhaul Components

The backhaul components are either *remote* backhaul components or *central* backhaul components. Remote components are the components that are not physically located next to the recording truck. Central components are physically located at the recording truck. Both remote and central backhauls are composed of the following:

- ◆ Base Station Unit (BSU) Kit
- ◆ Antenna
- ◆ Radio Kit
- ◆ Mast Kit

The following figure shows the backhaul components packed for transport:

TBD

Figure 3–4 Backhaul Components Packed for Transport

3.2.1 BSU Components

The following table lists the BSU kit components:

Table 3–1 Base Station Unit Kit

Remote Backhaul Components		Central Backhaul Components	
Item	Reference	Item	Reference
BSU (10-0009)	<i>"BSU" on page 35</i>	BSU (10-0009)	<i>"BSU" on page 35</i>
PoE Switch Unit (10-0012)	<i>"PoE Switch Unit" on page 36</i>	PoE Switch Unit (10-0012)	<i>"PoE Switch Unit" on page 36</i>
Battery (10-0015)	<i>"Battery and Power Supply" on page 37</i>	Power Supply, 24 V (75-0017)	<i>"Battery and Power Supply" on page 37</i>
Cable Assembly, BSU-to-PoE Switch (60-0008)	<i>"Cables" on page 38</i>	Cable Assembly, BSU at truck (60-0012)	<i>"Cables" on page 38</i>
Cable, PoE Switch-to-Battery (60-0011)	<i>"Cables" on page 38</i>	Cable, Power Supply-to-PoE (# TBD)	<i>"Cables" on page 38</i>
		Ethernet Cable, 25 ft (65-0046)	<i>"Cables" on page 38</i>

3.2.1.1 BSU

The Base Station Unit (BSU) is shown in the following figure:

3. Backhaul

Backhaul Components



Figure 3–5 Base Station Unit (BSU)

Before the Central Software System can communicate with the BSU, you must set up the backhaul.

 **NOTE**

See “D. LED Indicators” on page 100 for an explanation of the LED status and error conditions.

3.2.1.2 PoE Switch Unit

Power over Ethernet (PoE) is a technology that passes electrical power along an Ethernet cable. PoE is used where DC power is not available and USB unsuitable.

Power can be supplied at the end of a network span or somewhere in the middle. PoE switches supply power at the end of a span. PoE injectors supply power somewhere between the PoE switch and the powered device. They inject power and do not affect the data.

The PoE is shown in the following figure:



Figure 3–6 PoE

3.2.1.3 Battery and Power Supply

Power is supplied to the LTU components by way of a 24 Ah DC battery or power supply.



The backhaul power requirements vary depending on the hardware in use and period of use. For example, you may be using one or two radios. Supply enough power to ensure there is enough power for the entire duration of the time you are using the backhaul.

A 24 Ah battery is adequate if a recharged battery is installed for every 12 hours of use.

Wireless Seismic, Inc. recommends using a protective battery case as shown in the following figure:

3. Backhaul

Backhaul Components



Figure 3–7 Protective Battery Case

3.2.1.4 Cables

The following cables are used in the backhaul:

- ◆ BSU-to-PoE Switch 27-pin to RJ45 (60-0008)
- ◆ BSU at Recording Truck 27-pin to RJ45 (60-0012)
- ◆ PoE Switch-to-Battery 2-pin to 2-pin (60-0011)
- ◆ Power Supply-to-PoE (# TBD)
- ◆ Ethernet Cable, 25 ft (65-0046)
- ◆ TBD – Fiber Optic Cable

To ensure a protected connection, be sure to use an Ethernet cable with a protective shell (65-0051) when connecting Ethernet cables to the PoE. An example is shown in the following figure:



Figure 3–8 Protective Ethernet Connector

3.2.2 Antennas

The following table lists the supported antennas for the BSUs and the WRUs. The remote and central backhauls use the same antennas:

Table 3–2 Antenna Specifications

Model	Frequency (MHz)	Gain	Vertical Bandwidth	Weight	Dimension (Length x Diameter)
WSI 65-0067	2400-2485	9 dBi	14°	0.8 lbs 0.5 kg	27 x 0.6 in 690 x 15 mm
WSI 6060-001-01	2400-2485	7 dBi	18°	0.6 lbs 0.3 kg	21 x 0.6 in 540 x 15 mm
WSI 65-0023	2400-2485	5 dBi	25°	0.5 lbs 0.2 kg	12 x 0.6 in 355 x 15 mm
WSI 65-0025	2400-2485	2 dBi @ 2.4	120°	1.6 oz 45.4 g	7.6 x 0.5 in 193 x 12.7 mm

The Fluidmesh radios have built-in antennas (see *“Radio Kit Components”* on page 39 for details).

There is an *auto-power-leveling* feature built into the firmware. It works in conjunction with the RSSI parameters to keep the power at a defined level.

3.2.3 Radio Kit Components

The following table lists the Radio Kit components:

Table 3–3 Radio Kit

Remote Backhaul Components		Central Backhaul Components	
Item	Reference	Item	Reference
Radio, Fluidmesh® FM1100 (75-0014)	<i>“FM1100 Radio” on page 40</i>	Radio, Fluidmesh® FM3100 (75-0014)	<i>“FM1100 Radio” on page 40</i>
Software, Fluidmesh® FM1100-30 (47-0006)	<i>“FM3100 Radio” on page 41</i>	Software, Fluidmesh® FM3100-30 (47-00067)	<i>“FM3100 Radio” on page 41</i>

Refer to the Fluidmesh datasheet for FCC information and other technical specifications on the FM1100 and FM3100 radios. See one of the following locations for details:

- ◆ http://www.fluidmesh.com/press-room/product-literature/doc_details/160-fluidmesh-mito-series
- ◆ *“C. Fluidmesh Radio Specifications” on page 94*

The Fluidmesh radios can operate on at 4.9 GHz, and 5.1 - 5.8 GHz. The preferred frequency is configured through a user interface (see *“Configure the Radios”* on page 46 for instructions).

3. Backhaul

Backhaul Components

Each radio is assigned a color that represents the channel assignment, allowing field personnel to quickly orient the radios in the proper direction. An example is shown in the following figure:

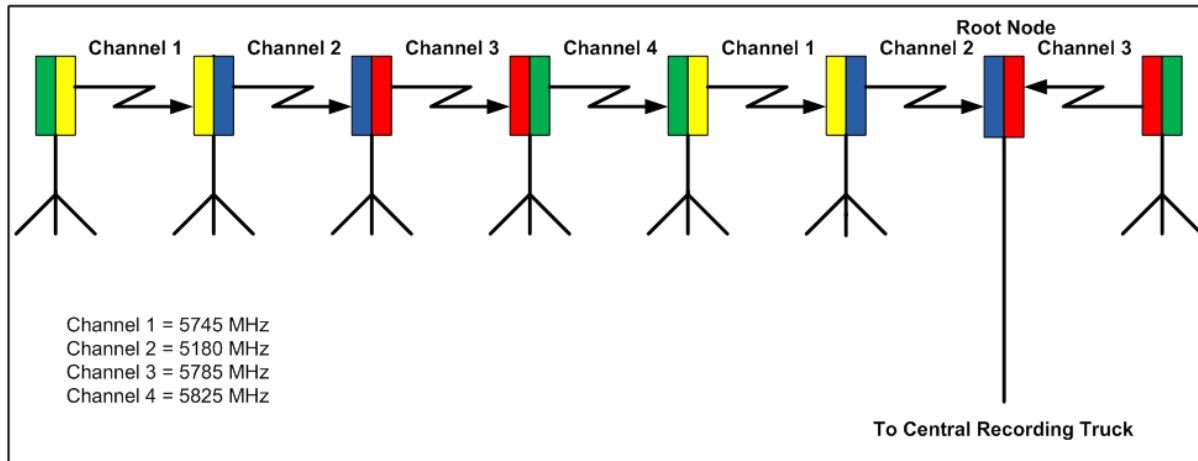

Figure 3–9 Channel Color Example

The Fluidmesh default IP address is 192.168.0.10.

3.2.3.1 FM1100 Radio

The FM1100 radio is used on the masts for the remote backhauls and is shown in the following figure:

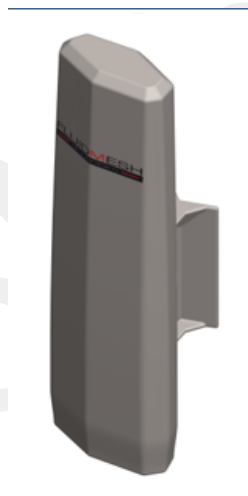

Figure 3–10 FM1100 Radio