



FCC TEST REPORT (15.247)

REPORT NO.: RF121213E08

MODEL NO.: OAP9112A-17, ECWO5110, ECWO5110-L,
SMC2980W-AN, SMC2891W-AN,
SMC2890W-AN-L, SMC2891W-AN-L

FCC ID: YZKSMC2891WAN

RECEIVED: Dec. 13, 2012

TESTED: Jan. 03 to 11, 2013

ISSUED: Jan. 29, 2013

APPLICANT: Edgecore Networks Corporation.

ADDRESS: No.1, Creation Rd. III, Hsinchu Science
Park, Hsinchu 30077, Taiwan, R.O.C

ISSUED BY: Bureau Veritas Consumer Products Services
(H.K.) Ltd., Taoyuan Branch Hsin Chu Laboratory

LAB ADDRESS : No. 81-1, Lu Liao Keng, 9th Ling, Wu Lung Tsuen,
Chiung Lin Hsiang, Hsin Chu Hsien 307, Taiwan,
R.O.C.

TEST LOCATION (1): No. 81-1, Lu Liao Keng, 9th Ling, Wu Lung Tsuen,
Chiung Lin Hsiang, Hsin Chu Hsien 307, Taiwan,
R.O.C.

TEST LOCATION (2): No. 49, Ln. 206, Wende Rd., Shangshan Tsuen,
Chiung Lin Hsiang, Hsin Chu Hsien 307, Taiwan,
R.O.C.

This report should not be used by the client to claim
product certification, approval, or endorsement by TAF
or any government agencies.



This report is for your exclusive use. Any copying or replication of this report to or for any other person or entity, or use of our name or trademark, is permitted only with our prior written permission. This report sets forth our findings solely with respect to the test samples identified herein. The results set forth in this report are not indicative or representative of the quality or characteristics of the lot from which a test sample was taken or any similar or identical product unless specifically and expressly noted. Our report includes all of the tests requested by you and the results thereof based upon the information that you provided to us. You have 60 days from date of issuance of this report to notify us of any material error or omission caused by our negligence, provided, however, that such notice shall be in writing and shall specifically address the issue you wish to raise. A failure to raise such issue within the prescribed time shall constitute your unqualified acceptance of the completeness of this report, the tests conducted and the correctness of the report contents. Unless specific mention, the uncertainty of measurement has been explicitly taken into account to declare the compliance or non-compliance to the specification



A D T

Table of Contents

RELEASE CONTROL RECORD	5
1. CERTIFICATION	6
2. SUMMARY OF TEST RESULTS	7
2.1 MEASUREMENT UNCERTAINTY	8
3. GENERAL INFORMATION	9
3.1 GENERAL DESCRIPTION OF EUT	9
3.2 DESCRIPTION OF TEST MODES	12
3.2.1 TEST MODE APPLICABILITY AND TESTED CHANNEL DETAIL	13
3.3 GENERAL DESCRIPTION OF APPLIED STANDARDS	16
3.4 DESCRIPTION OF SUPPORT UNITS	17
3.5 CONFIGURATION OF SYSTEM UNDER TEST	17
4. TEST TYPES AND RESULTS (FOR 2.4GHz, 2.400 ~ 2.4835GHz Band)	18
4.1 CONDUCTED EMISSION MEASUREMENT	18
4.1.1 LIMITS OF CONDUCTED EMISSION MEASUREMENT	18
4.1.2 TEST INSTRUMENTS	18
4.1.3 TEST PROCEDURES	19
4.1.4 DEVIATION FROM TEST STANDARD	19
4.1.5 TEST SETUP	19
4.1.6 EUT OPERATING CONDITIONS	20
4.1.7 TEST RESULTS	21
4.2 RADIATED EMISSION AND BANDEDGE MEASUREMENT	23
4.2.1 LIMITS OF RADIATED EMISSION AND BANDEDGE MEASUREMENT	23
4.2.2 TEST INSTRUMENTS	24
4.2.3 TEST PROCEDURES	26
4.2.4 DEVIATION FROM TEST STANDARD	26
4.2.5 TEST SETUP	27
4.2.6 EUT OPERATING CONDITIONS	27
4.2.7 TEST RESULTS	28
4.3 6dB BANDWIDTH MEASUREMENT	41
4.3.1 LIMITS OF 6dB BANDWIDTH MEASUREMENT	41
4.3.2 TEST INSTRUMENTS	41
4.3.3 TEST PROCEDURE	41
4.3.4 DEVIATION FROM TEST STANDARD	41
4.3.5 TEST SETUP	41
4.3.6 EUT OPERATING CONDITIONS	41
4.3.7 TEST RESULTS	42
4.4 CONDUCTED OUTPUT POWER MEASUREMENT	43
4.4.1 LIMITS OF MAXIMUM PEAK OUTPUT POWER MEASUREMENT	43
4.4.2 INSTRUMENTS	43
4.4.3 TEST PROCEDURES	43
4.4.4 DEVIATION FROM TEST STANDARD	43
4.4.5 TEST SETUP	43
4.4.6 EUT OPERATING CONDITIONS	43
4.4.7 TEST RESULTS	44
4.5 POWER SPECTRAL DENSITY MEASUREMENT	45
4.5.1 LIMITS OF POWER SPECTRAL DENSITY MEASUREMENT	45
4.5.2 TEST INSTRUMENTS	45
4.5.3 TEST PROCEDURE	45
4.5.4 DEVIATION FROM TEST STANDARD	45
4.5.5 TEST SETUP	45



4.5.6	EUT OPERATING CONDITION.....	45
4.5.7	TEST RESULTS.....	46
4.6	CONDUCTED OUT-BAND EMISSION MEASUREMENT.....	47
4.6.1	LIMITS OF CONDUCTED OUT-BAND EMISSION MEASUREMENT.....	47
4.6.2	TEST INSTRUMENTS.....	47
4.6.3	TEST PROCEDURE.....	47
4.6.4	DEVIATION FROM TEST STANDARD.....	48
4.6.5	TEST SETUP.....	48
4.6.6	EUT OPERATING CONDITION.....	48
4.6.7	TEST RESULTS.....	48
5.	TEST TYPES AND RESULTS (FOR 5gHz, 5.725~5.850GHz Band).....	55
5.1	CONDUCTED EMISSION MEASUREMENT.....	55
5.1.1	LIMITS OF CONDUCTED EMISSION MEASUREMENT.....	55
5.1.2	TEST INSTRUMENTS.....	55
5.1.3	TEST PROCEDURES.....	56
5.1.4	DEVIATION FROM TEST STANDARD.....	56
5.1.5	TEST SETUP.....	56
5.1.6	EUT OPERATING CONDITIONS.....	57
5.1.7	TEST RESULTS.....	58
5.2	RADIATED AND BANDEDGE EMISSION MEASUREMENT.....	60
5.2.1	LIMITS OF RADIATED AND BANDEDGE EMISSION MEASUREMENT.....	60
5.2.2	TEST INSTRUMENTS.....	61
5.2.3	TEST PROCEDURES.....	62
5.2.4	DEVIATION FROM TEST STANDARD.....	62
5.2.5	TEST SETUP.....	63
5.2.6	EUT OPERATING CONDITIONS.....	63
5.2.7	TEST RESULTS.....	64
5.3	6dB BANDWIDTH MEASUREMENT.....	73
5.3.1	LIMITS OF 6dB BANDWIDTH MEASUREMENT.....	73
5.3.2	TEST INSTRUMENTS.....	73
5.3.3	TEST PROCEDURE.....	73
5.3.4	DEVIATION FROM TEST STANDARD.....	73
5.3.5	TEST SETUP.....	73
5.3.6	EUT OPERATING CONDITIONS.....	73
5.3.7	TEST RESULTS.....	74
5.4	CONDUCTED OUTPUT POWER MEASUREMENT.....	75
5.4.1	LIMITS OF CONDUCTED OUTPUT POWER MEASUREMENT.....	75
5.4.2	INSTRUMENTS.....	75
5.4.3	TEST PROCEDURES.....	75
5.4.4	DEVIATION FROM TEST STANDARD.....	75
5.4.5	TEST SETUP.....	75
5.4.6	EUT OPERATING CONDITIONS.....	75
5.4.7	TEST RESULTS.....	76
5.5	POWER SPECTRAL DENSITY MEASUREMENT.....	77
5.5.1	LIMITS OF POWER SPECTRAL DENSITY MEASUREMENT.....	77
5.5.2	TEST INSTRUMENTS.....	77
5.5.3	TEST PROCEDURE.....	77
5.5.4	DEVIATION FROM TEST STANDARD.....	77
5.5.5	TEST SETUP.....	77
5.5.6	EUT OPERATING CONDITION.....	77
5.5.7	TEST RESULTS.....	78
5.6	CONDUCTED OUT-BAND EMISSION MEASUREMENT.....	79



A D T

5.6.1	LIMITS OF CONDUCTED OUT-BAND EMISSION MEASUREMENT.....	79
5.6.2	TEST INSTRUMENTS.....	79
5.6.3	TEST PROCEDURE.....	79
5.6.4	DEVIATION FROM TEST STANDARD.....	80
5.6.5	TEST SETUP	80
5.6.6	EUT OPERATING CONDITION.....	80
5.6.7	TEST RESULTS	80
6.	PHOTOGRAPHS OF THE TEST CONFIGURATION.....	86
7.	INFORMATION ON THE TESTING LABORATORIES	87
8.	APPENDIX A - MODIFICATIONS RECORDERS FOR ENGINEERING CHANGES TO THE EUT BY THE LAB.....	88



A D T

RELEASE CONTROL RECORD

ISSUE NO.	REASON FOR CHANGE	DATE ISSUED
RF121213E08	Original release	Jan. 29, 2013



1. CERTIFICATION

PRODUCT: 802.11a/b/g/n Outdoor Dual Band Wireless Access Point

BRAND NAME: Accton, Edge-corE, SMC

MODEL NO.: OAP9112A-17, ECWO5110, ECWO5110-L, SMC2980W-AN, SMC2891W-AN, SMC2890W-AN-L, SMC2891W-AN-L

TEST SAMPLE: R&D SAMPLE

APPLICANT: Edgecore Networks Corporation.

TESTED: Jan. 03 to 11, 2013

STANDARDS: FCC Part 15, Subpart C (Section 15.247)
ANSI C63.10-2009

The above equipment (Model: OAP9112A-17) has been tested by **Bureau Veritas Consumer Products Services (H.K.) Ltd., Taoyuan Branch**, and found compliance with the requirement of the above standards. The test record, data evaluation & Equipment Under Test (EUT) configurations represented herein are true and accurate accounts of the measurements of the sample's EMC characteristics under the conditions specified in this report.

PREPARED BY :  , **DATE:** Jan. 29, 2013
(Lori Chung, Specialist)

APPROVED BY :  , **DATE:** Jan. 29, 2013
(May Chen, Deputy Manager)



A D T

2. SUMMARY OF TEST RESULTS

The EUT has been tested according to the following specifications:

For 2.4GHz, 2400~2483.5MHz Band

APPLIED STANDARD: FCC PART 15, SUBPART C (SECTION 15.247)			
STANDARD SECTION	TEST TYPE	RESULT	REMARK
15.207	AC Power Conducted Emission	PASS	Meet the requirement of limit. Minimum passing margin is -7.83dB at 3.41797MHz
15.247(d) 15.209	Radiated Emissions	PASS	Meet the requirement of limit. Minimum passing margin is -0.5dB at 2483.50MHz
15.247(d)	Band Edge Measurement	PASS	Meet the requirement of limit.
15.247(a)(2)	6dB bandwidth	PASS	Meet the requirement of limit.
15.247(b)	Conducted Output power	PASS	Meet the requirement of limit.
15.247(e)	Power Spectral Density	PASS	Meet the requirement of limit.
15.203	Antenna Requirement	PASS	Antenna connectors are N-Female, I-PEX and N-MALE not a standard connector.

For 5GHz, 5725~5850MHz Band

APPLIED STANDARD: FCC PART 15, SUBPART C (SECTION 15.247)			
STANDARD SECTION	TEST TYPE	RESULT	REMARK
15.207	AC Power Conducted Emission	PASS	Meet the requirement of limit. Minimum passing margin is -8.30dB at 3.34766MHz
15.247(d) 15.209	Radiated Emissions	PASS	Meet the requirement of limit. Minimum passing margin is -0.7dB at 5382.20MHz
15.247(d)	Band Edge Measurement	PASS	Meet the requirement of limit.
15.247(a)(2)	6dB bandwidth	PASS	Meet the requirement of limit.
15.247(b)	Conducted Output power	PASS	Meet the requirement of limit.
15.247(e)	Power Spectral Density	PASS	Meet the requirement of limit.
15.203	Antenna Requirement	PASS	Antenna connectors are N-Female, I-PEX and N-MALE not a standard connector.

NOTE: The EUT was operating in 2.400 ~ 2.4835GHz, 5.15~5.25GHz and 5.725~5.850GHz frequencies band. This report was recorded the RF parameters including 2.400 ~ 2.4835GHz and 5.725~5.850GHz. For the 5.15~5.25GHz RF parameters was recorded in another test report.



A D T

2.1 MEASUREMENT UNCERTAINTY

Where relevant, the following measurement uncertainty levels have been estimated for tests performed on the EUT as specified in CISPR 16-4-2:

This uncertainty represents an expanded uncertainty expressed at approximately the 95% confidence level using a coverage factor of $k=2$.

Measurement	Value
Conducted emissions	2.98 dB
Radiated emissions (30MHz-1GHz)	5.59 dB
Radiated emissions (1GHz -6GHz) for Chamber G	3.56 dB
Radiated emissions (1GHz -6GHz) for Chamber H	3.84 dB
Radiated emissions (6GHz -18GHz) for Chamber G	4.10 dB
Radiated emissions (6GHz -18GHz) for Chamber H	4.09 dB
Radiated emissions (18GHz -40GHz)	4.24 dB



A D T

3. GENERAL INFORMATION

3.1 GENERAL DESCRIPTION OF EUT

PRODUCT	802.11a/b/g/n Outdoor Dual Band Wireless Access Point
MODEL NO.	OAP9112A-17, ECWO5110, ECWO5110-L, SMC2980W-AN, SMC2891W-AN, SMC2890W-AN-L, SMC2891W-AN-L
POWER SUPPLY	DC 55V from POE
MODULATION TYPE	CCK, DQPSK, DBPSK for DSSS 64QAM, 16QAM, QPSK, BPSK for OFDM
MODULATION TECHNOLOGY	DSSS,OFDM
TRANSFER RATE	802.11b: up to 11Mbps 802.11a / g: up to 54Mbps 802.11n: up to 300Mbps
OPERATING FREQUENCY	For 15.407 802.11a/n: 5.18 ~ 5.24GHz
	For 15.247 802.11b/g/n: 2.412 ~ 2.462GHz 802.11a/n: 5.745 ~ 5.825GHz
NUMBER OF CHANNEL	For 15.407 4 for 802.11a, 802.11n (HT20) 2 for 802.11n (HT40)
	For 15.247 (2.4GHz) 11 for 802.11b, 802.11g, 802.11n (HT20) 7 for 802.11n (HT40) For 15.247 (5GHz) 5 for 802.11a, 802.11n (HT20) 2 for 802.11n (HT40)



A D T

MAXIMUM OUTPUT POWER	<p>For 15.407 802.11a: 16.982mW 802.11n (HT20): 12.142mW 802.11n (HT40): 12.082mW</p> <p>For 15.247 (2.4GHz) 802.11b: 147.911mW 802.11g: 141.254mW 802.11n (HT20): 129.268mW 802.11n (HT40): 60.463mW</p> <p>For 15.247 (5GHz) 802.11a: 83.176mW 802.11n (HT20): 126.225mW 802.11n (HT40): 126.325mW</p>
ANTENNA TYPE	Please see NOTE
DATA CABLE	NA
I/O PORTS	Refer to user's manual
ASSOCIATED DEVICES	NA

NOTE:

- There are 2.4GHz and 5GHz WLAN technology used for the EUT. The test report of EUT listed as below table:

Function	Report No.
WLAN	RF121213E08 (15.247) RF121213E08-1(15.407)

- The EUT has three brand names and seven model names which are identical to each other in all aspects except for the following table:

Brand Name	Model No.	Description
Accton	OAP9112A-17	for different marketing
Edge-corE	ECWO5110	
	ECWO5110-L	
SMC	SMC2980W-AN	
	SMC2891W-AN	
	SMC2890W-AN-L	
	SMC2891W-AN-L	

From the above models, model: **OAP9112A-17** was selected as representative model for the test and its data was recorded in this report.



A D T

3. The EUT must be supplied with a POE as below information:

POE (Only for test does not sale)		
Brand	Model No.	Spec.
MOTOROLA	PD-7001G	AC Input : 100-240V, 0.8A, 50-60Hz DC Output : 55V, 0.57A

4. The antennas provided to the EUT, please refer to the following table:

For 2.4GHz								
Transmitter Circuit	Brand	Model name	Gain (dBi) Exclude cable loss	Antenna Type	Connector	Frequency range (MHz to MHz)	Cable Loss (dB)	Cable Length (mm)
Chain (0)	Accton	120G0000	3.38	Omni-Directional	N-MALE	2412~2483.5	2.2	210
Chain (1)	Accton	0051A						
For 5GHz								
Transmitter Circuit	Brand	Model name	Gain (dBi) Exclude cable loss	Antenna Type	Connector	Frequency range (MHz to MHz)	Cable Loss (dB)	Cable Length (mm)
Chain (0)	Accton	120G0000 0052A	12.62	PANEL	N-Female	5150~5875	2.1	1500
Chain (1)	Accton	120G0000 0050A	12.05	PANEL	I-PEX	5150~5875	1.7	160

Note: For 5GHz antennas, there are two antennas will transmit simultaneously (one is Vertical and another is Horizontal).

5. The EUT incorporates a MIMO function without beam forming.

MODULATION MODE	TX/RX FUNCTION
802.11a	1TX/1RX
802.11b	1TX/1RX
802.11g	1TX/1RX
802.11n (HT20)	2TX/2RX
802.11n (HT40)	2TX/2RX

6. Conducted emission and radiated emission of the simultaneous operation (2.4GHz & 5GHz) has been evaluated and no non-compliance was found.

7. When the EUT operating in 802.11n, the software operation, which is defined by manufacturer, MCS (Modulation and Coding Schemes) from 0 to 15.

8. The above EUT information was declared by the manufacturer and for more detailed features description, please refer to the manufacturer's specifications or User's Manual.



A D T

3.2 DESCRIPTION OF TEST MODES

Operated in 2400 ~ 2483.5MHz band:

11 channels are provided for 802.11b, 802.11g, 802.11n (HT20):

CHANNEL	FREQUENCY	CHANNEL	FREQUENCY
1	2412MHz	7	2442MHz
2	2417MHz	8	2447MHz
3	2422MHz	9	2452MHz
4	2427MHz	10	2457MHz
5	2432MHz	11	2462MHz
6	2437MHz		

7 channels are provided for 802.11n (HT40):

CHANNEL	FREQUENCY	CHANNEL	FREQUENCY
3	2422MHz	7	2442MHz
4	2427MHz	8	2447MHz
5	2432MHz	9	2452MHz
6	2437MHz		

Operated in 5725 ~ 5850MHz band:

5 channels are provided for 802.11a, 802.11n (HT20):

CHANNEL	FREQUENCY	CHANNEL	FREQUENCY
149	5745 MHz	161	5805 MHz
153	5765 MHz	165	5825 MHz
157	5785 MHz		

2 channels are provided for 802.11n (HT40):

CHANNEL	FREQUENCY
151	5755 MHz
159	5795 MHz

3.2.1 TEST MODE APPLICABILITY AND TESTED CHANNEL DETAIL

EUT CONFIGURE MODE	APPLICABLE TO					DESCRIPTION
	PLC	RE < 1G	RE ≥ 1G	APCM	OB	
-	√	√	√	√	√	-

Where **PLC**: Power Line Conducted Emission **RE < 1G**: Radiated Emission below 1GHz
RE ≥ 1G: Radiated Emission above 1GHz **APCM**: Antenna Port Conducted Measurement
OB: Conducted Out-Band Emission Measurement

Note: The EUT had been pre-tested on the positioned of each 2 axis. The worst case was found when positioned on **Y-plane**.

POWER LINE CONDUCTED EMISSION TEST:

- Pre-Scan has been conducted to determine the worst-case mode from all possible combinations between available modulations, data rates and antenna ports (if EUT with antenna diversity architecture).
- Following channel(s) was (were) selected for the final test as listed below.

MODE	AVAILABLE CHANNEL	TESTED CHANNEL	MODULATION TECHNOLOGY	MODULATION TYPE	DATA RATE (Mbps)
802.11b	1 to 11	6	DSSS	DBPSK	1
For 5 GHz 802.11n (HT20)	149 to 165	149	OFDM	BPSK	6.5

RADIATED EMISSION TEST (BELOW 1 GHz):

- Pre-Scan has been conducted to determine the worst-case mode from all possible combinations between available modulations, data rates and antenna ports (if EUT with antenna diversity architecture).
- Following channel(s) was (were) selected for the final test as listed below.

MODE	AVAILABLE CHANNEL	TESTED CHANNEL	MODULATION TECHNOLOGY	MODULATION TYPE	DATA RATE (Mbps)
802.11b	1 to 11	6	DSSS	DBPSK	1
For 5 GHz 802.11n (HT20)	149 to 165	149	OFDM	BPSK	6.5



A D T

RADIATED EMISSION TEST (ABOVE 1 GHz):

- Pre-Scan has been conducted to determine the worst-case mode from all possible combinations between available modulations, data rates and antenna ports (if EUT with antenna diversity architecture).
- Following channel(s) was (were) selected for the final test as listed below.

MODE	AVAILABLE CHANNEL	TESTED CHANNEL	MODULATION TECHNOLOGY	MODULATION TYPE	DATA RATE (Mbps)
802.11b	1 to 11	1, 6, 11	DSSS	DBPSK	1
802.11g	1 to 11	1, 6, 11	OFDM	BPSK	6
For 2.4 GHz 802.11n (HT20)	1 to 11	1, 6, 11	OFDM	BPSK	6.5
For 2.4 GHz 802.11n (HT40)	3 to 9	3, 6, 9	OFDM	BPSK	13.5
802.11a	149 to 165	149, 157, 165	OFDM	BPSK	6
For 5 GHz 802.11n (HT20)	149 to 165	149, 157, 165	OFDM	BPSK	6.5
For 5 GHz 802.11n (HT40)	151 to 159	151, 159	OFDM	BPSK	13.5

ANTENNA PORT CONDUCTED MEASUREMENT:

- Pre-Scan has been conducted to determine the worst-case mode from all possible combinations between available modulations, data rates and antenna ports (if EUT with antenna diversity architecture).
- Following channel(s) was (were) selected for the final test as listed below.

MODE	AVAILABLE CHANNEL	TESTED CHANNEL	MODULATION TECHNOLOGY	MODULATION TYPE	DATA RATE (Mbps)
802.11b	1 to 11	1, 6, 11	DSSS	DBPSK	1
802.11g	1 to 11	1, 6, 11	OFDM	BPSK	6
For 2.4 GHz 802.11n (HT20)	1 to 11	1, 6, 11	OFDM	BPSK	6.5
For 2.4 GHz 802.11n (HT40)	3 to 9	3, 6, 9	OFDM	BPSK	13.5
802.11a	149 to 165	149, 157, 165	OFDM	BPSK	6
For 5 GHz 802.11n (HT20)	149 to 165	149, 157, 165	OFDM	BPSK	6.5
For 5 GHz 802.11n (HT40)	151 to 159	151, 159	OFDM	BPSK	13.5



A D T

CONDUCTED OUT-BAND EMISSION MEASUREMENT:

- Pre-Scan has been conducted to determine the worst-case mode from all possible combinations between available modulations, data rates and antenna ports (if EUT with antenna diversity architecture).
- Following channel(s) was (were) selected for the final test as listed below.

MODE	AVAILABLE CHANNEL	TESTED CHANNEL	MODULATION TECHNOLOGY	MODULATION TYPE	DATA RATE (Mbps)
802.11b	1 to 11	1, 6, 11	DSSS	DBPSK	1
802.11g	1 to 11	1, 6, 11	OFDM	BPSK	6
For 2.4 GHz 802.11n (HT20)	1 to 11	1, 6, 11	OFDM	BPSK	6.5
For 2.4 GHz 802.11n (HT40)	3 to 9	3, 6, 9	OFDM	BPSK	13.5
802.11a	149 to 165	149, 157, 165	OFDM	BPSK	6
For 5 GHz 802.11n (HT20)	149 to 165	149, 157, 165	OFDM	BPSK	6.5
For 5 GHz 802.11n (HT40)	151 to 159	151, 159	OFDM	BPSK	13.5

TEST CONDITION:

APPLICABLE TO	ENVIRONMENTAL CONDITIONS	INPUT POWER	TESTED BY
PLC	25deg. C, 52%RH	120Vac, 60Hz	Timmy Hu
RE<1G	25deg. C, 67%RH	120Vac, 60Hz	Robert Cheng
RE ³ 1G	26deg. C, 75%RH	120Vac, 60Hz	Robert Cheng
	23deg. C, 66%RH	120Vac, 60Hz	Robert Cheng
APCM	25deg. C, 60%RH	120Vac, 60Hz	Amos Chuang
OB	25deg. C, 60%RH	120Vac, 60Hz	Amos Chuang

3.3 GENERAL DESCRIPTION OF APPLIED STANDARDS

The EUT is a RF product. According to the specifications of the manufacturer, it must comply with the requirements of the following standards:

FCC Part 15, Subpart C. (15.247)

558074 D01 DTS Meas Guidance

662911 D01 Multiple Transmitter Output

ANSI C63.10-2009

All test items have been performed and recorded as per the above standards.

Note: The EUT has been verified to comply with the requirements of FCC Part 15, Subpart B, Class B (DoC). The test report has been issued separately.

3.4 DESCRIPTION OF SUPPORT UNITS

The EUT has been tested as an independent unit together with other necessary accessories or support units. The following support units or accessories were used to form a representative test configuration during the tests.

NO.	PRODUCT	BRAND	MODEL NO.	SERIAL NO.	FCC ID
1	NOTEBOOK COMPUTER	DELL	PP32LA	FSLB32S	FCC DoC

NO.	SIGNAL CABLE DESCRIPTION OF THE ABOVE SUPPORT UNITS
1	UTP cable (3m)

NOTE: All power cords of the above support units are non shielded (1.8m).

3.5 CONFIGURATION OF SYSTEM UNDER TEST

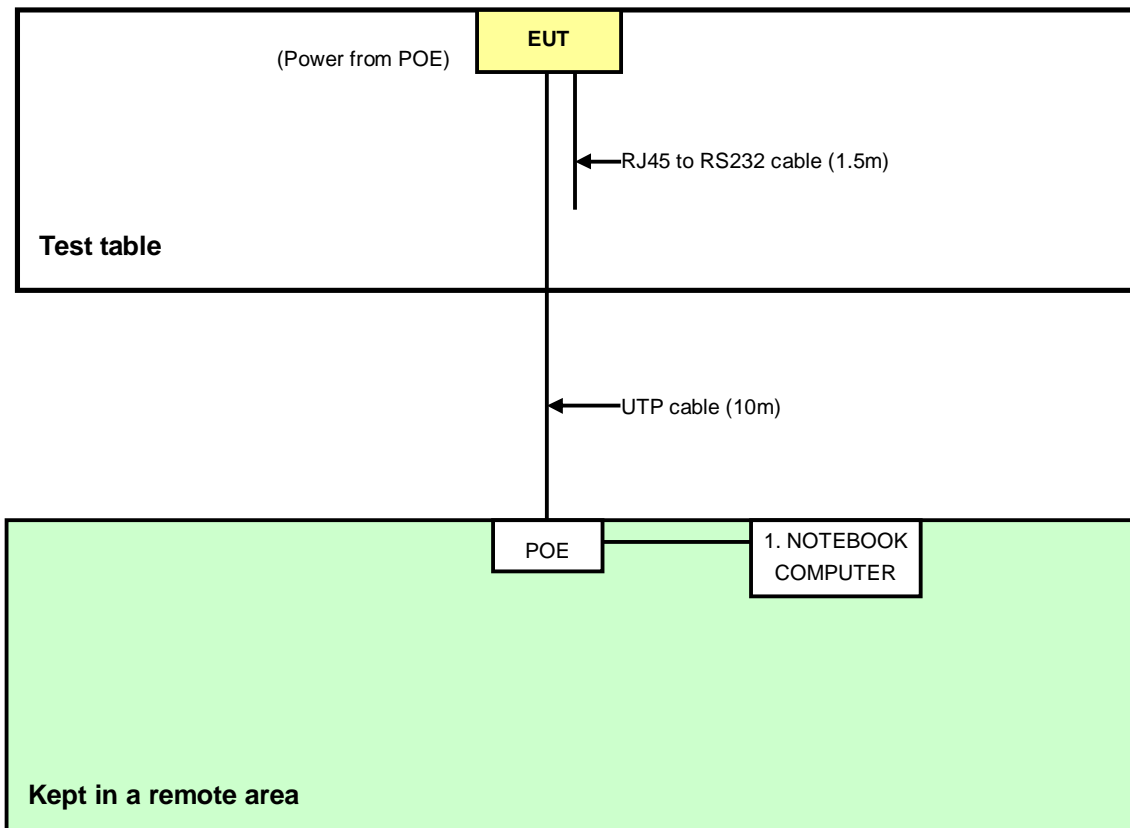



A D T

4. TEST TYPES AND RESULTS (FOR 2.4GHz, 2.400 ~ 2.4835GHz Band)

4.1 CONDUCTED EMISSION MEASUREMENT

4.1.1 LIMITS OF CONDUCTED EMISSION MEASUREMENT

FREQUENCY OF EMISSION (MHz)	CONDUCTED LIMIT (dB μ V)	
	Quasi-peak	Average
0.15-0.5	66 to 56	56 to 46
0.5-5	56	46
5-30	60	50

- NOTE:**
1. The lower limit shall apply at the transition frequencies.
 2. The limit decreases in line with the logarithm of the frequency in the range of 0.15 to 0.50 MHz.

4.1.2 TEST INSTRUMENTS

DESCRIPTION & MANUFACTURER	MODEL NO.	SERIAL NO.	CALIBRATED DATE	CALIBRATED UNTIL
Test Receiver ROHDE & SCHWARZ	ESCS 30	100287	Feb. 29, 2012	Feb. 28, 2013
Line-Impedance Stabilization Network (for EUT) SCHWARZBECK	NSLK 8127	8127-523	Sep. 19, 2012	Sep. 20, 2013
Line-Impedance Stabilization Network (for Peripheral) ROHDE & SCHWARZ	ESH3-Z5	848773/004	Oct. 29, 2012	Oct. 28, 2013
RF Cable (JYEBAO)	5DFB	COACAB-002	Aug. 05, 2012	Aug. 04, 2013
50 ohms Terminator	50	3	Oct. 23, 2012	Oct. 22, 2013
Software ADT	BV ADT_Cond_V7.3.7 .3	NA	NA	NA

Note:

1. The calibration interval of the above test instruments is 12 months and the calibrations are traceable to NML/ROC and NIST/USA.
2. The test was performed in Shielded Room No. A.
3. The VCCI Con A Registration No. is C-817.
4. Tested Date: Jan. 03, 2013

4.1.3 TEST PROCEDURES

- a. The EUT was placed 0.4 meters from the conducting wall of the shielded room with EUT being connected to the power mains through a line impedance stabilization network (LISN). Other support units were connected to the power mains through another LISN.
- b. The two LISNs provide 50 ohm/ 50uH of coupling impedance for the measuring instrument.
- c. Both lines of the power mains connected to the EUT were checked for maximum conducted interference.
- d. The frequency range from 150kHz to 30MHz was searched. Emission levels under (Limit - 20dB) were not recorded.

NOTE:

1. The resolution bandwidth of test receiver is 9kHz for Quasi-peak detection (QP) & Average detection (AV).

4.1.4 DEVIATION FROM TEST STANDARD

No deviation

4.1.5 TEST SETUP

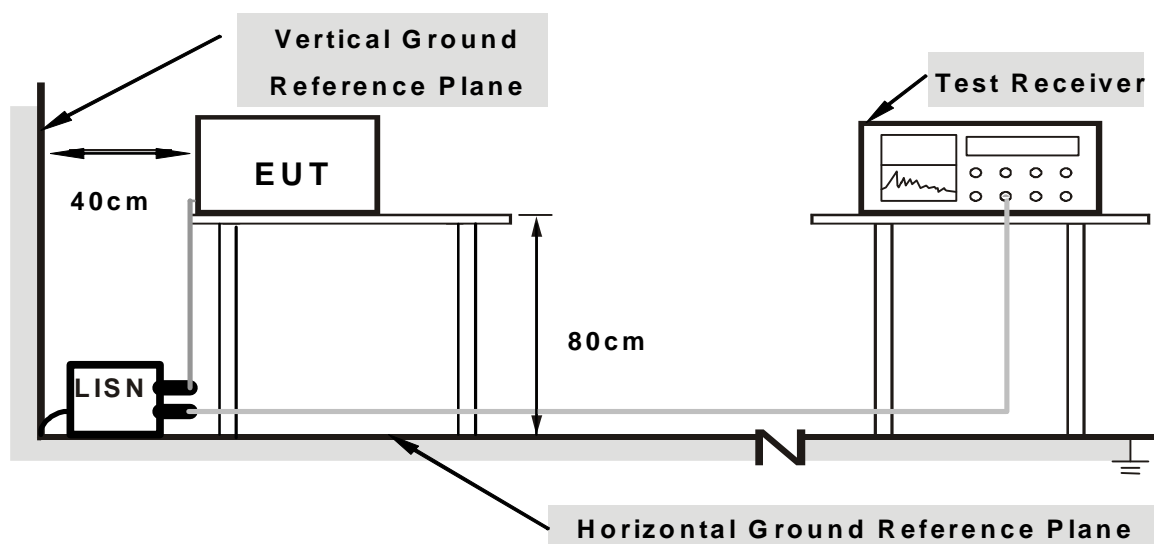

Note: 1. Support units were connected to second LISN.

For the actual test configuration, please refer to the related item – Photographs of the Test Configuration.



A D T

4.1.6 EUT OPERATING CONDITIONS

1. Turn on the power of EUT.
2. The communication partner run test program “art2_ver_2_20BIN.exe” to enable EUT under transmission/receiving condition continuously at specific channel frequency.

4.1.7 TEST RESULTS

PHASE	Line (L)	DETECTOR FUNCTION	Quasi-Peak (QP) / Average (AV)
--------------	----------	--------------------------	--------------------------------

No	Freq. [MHz]	Corr. Factor (dB)	Reading Value [dB (uV)]		Emission Level [dB (uV)]		Limit [dB (uV)]		Margin (dB)	
			Q.P.	AV.	Q.P.	AV.	Q.P.	AV.	Q.P.	AV.
			1	0.16172	0.10	40.40	40.00	40.50	40.10	65.38
2	0.27109	0.13	40.56	31.97	40.69	32.10	61.08	51.08	-20.40	-18.99
3	2.59766	0.26	41.16	34.39	41.42	34.65	56.00	46.00	-14.58	-11.35
4	2.73438	0.26	43.60	33.78	43.86	34.04	56.00	46.00	-12.14	-11.96
5	3.41797	0.29	44.25	37.88	44.54	38.17	56.00	46.00	-11.46	-7.83
6	12.82031	0.69	40.06	38.17	40.75	38.86	60.00	50.00	-19.25	-11.14

REMARKS:

1. Q.P. and AV. are abbreviations of quasi-peak and average individually.
2. The emission levels of other frequencies were very low against the limit.
3. Margin value = Emission level - Limit value
4. Correction factor = Insertion loss + Cable loss
5. Emission Level = Correction Factor + Reading Value.

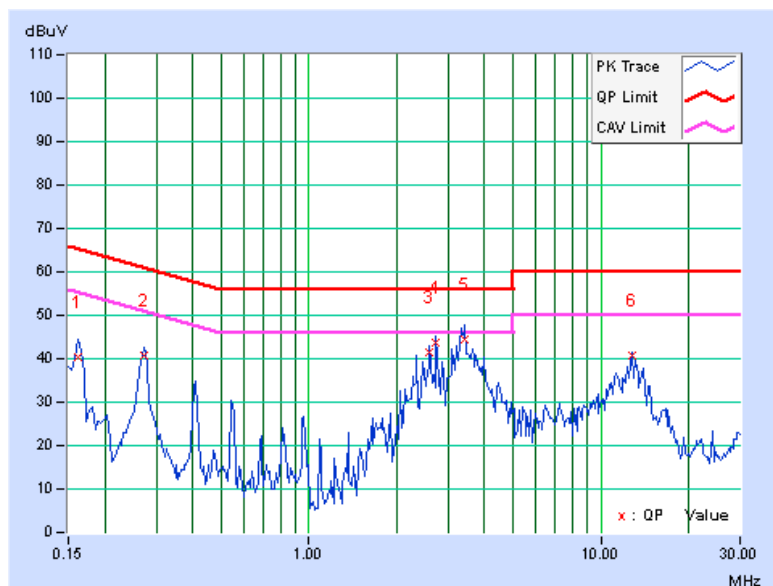

PHASE	Neutral (N)	DETECTOR FUNCTION	Quasi-Peak (QP) / Average (AV)
--------------	-------------	--------------------------	--------------------------------

No	Freq. [MHz]	Corr. Factor (dB)	Reading Value [dB (uV)]		Emission Level [dB (uV)]		Limit [dB (uV)]		Margin (dB)	
			Q.P.	AV.	Q.P.	AV.	Q.P.	AV.	Q.P.	AV.
	1	0.16562	0.15	39.85	39.48	40.00	39.63	65.18	55.18	-25.18
2	0.27109	0.16	38.19	36.35	38.35	36.51	61.08	51.08	-22.73	-14.57
3	2.73438	0.30	44.25	35.07	44.55	35.37	56.00	46.00	-11.45	-10.63
4	3.32813	0.32	42.97	36.61	43.29	36.93	56.00	46.00	-12.71	-9.07
5	3.90234	0.35	39.17	30.34	39.52	30.69	56.00	46.00	-16.48	-15.31
6	12.82031	0.62	39.05	37.17	39.67	37.79	60.00	50.00	-20.33	-12.21

REMARKS:

1. Q.P. and AV. are abbreviations of quasi-peak and average individually.
2. The emission levels of other frequencies were very low against the limit.
3. Margin value = Emission level - Limit value
4. Correction factor = Insertion loss + Cable loss
5. Emission Level = Correction Factor + Reading Value.

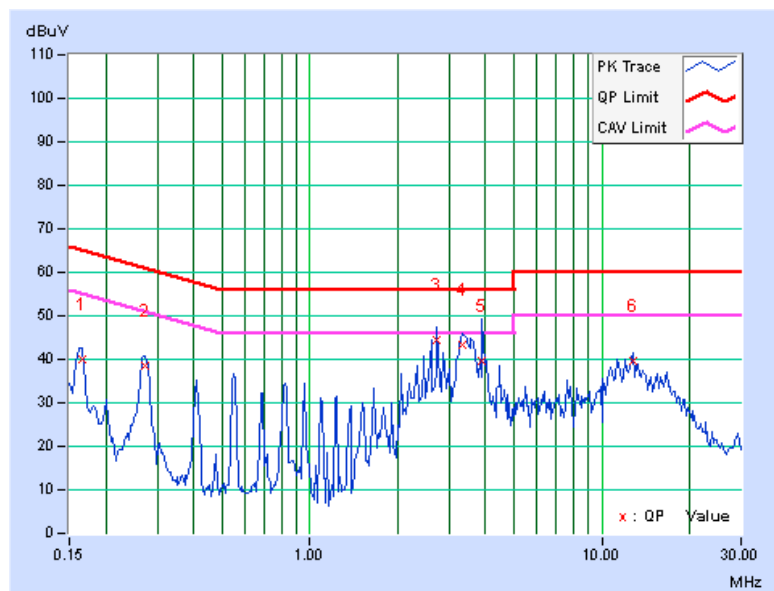



A D T

4.2 RADIATED EMISSION AND BANDEGE MEASUREMENT

4.2.1 LIMITS OF RADIATED EMISSION AND BANDEGE MEASUREMENT

Radiated emissions which fall in the restricted bands must comply with the radiated emission limits specified as below table. Other emissions shall be at least 30dB below the highest level of the desired power:

Frequencies (MHz)	Field strength (microvolts/meter)	Measurement distance (meters)
0.009-0.490	2400/F(kHz)	300
0.490-1.705	24000/F(kHz)	30
1.705-30.0	30	30
30-88	100	3
88-216	150	3
216-960	200	3
Above 960	500	3

NOTE:

1. The lower limit shall apply at the transition frequencies.
2. Emission level (dBuV/m) = 20 log Emission level (uV/m).
3. For frequencies above 1000MHz, the field strength limits are based on average detector, however, the peak field strength of any emission shall not exceed the maximum permitted average limits, specified above by more than 20dB under any condition of modulation.



A D T

4.2.2 TEST INSTRUMENTS

For below 1GHz

DESCRIPTION & MANUFACTURER	MODEL NO.	SERIAL NO.	CALIBRATED DATE	CALIBRATED UNTIL
Spectrum Analyzer Agilent	E4446A	MY48250254	July 09, 2012	July 08, 2013
Pre-Selector Agilent	N9039A	MY46520311	July 09, 2012	July 08, 2013
Signal Generator Agilent	N5181A	MY49060517	July 09, 2012	July 08, 2013
Pre-Amplifier Mini-Circuits	ZFL-1000VH2 B	AMP-ZFL-03	Nov. 14, 2012	Nov. 13, 2013
Pre-Amplifier Agilent	8449B	3008A02578	June 26, 2012	June 25, 2013
Pre-Amplifier SPACEK LABS	SLKKa-48-6	9K16	Nov. 14, 2012	Nov. 13, 2013
Trilog Broadband Antenna SCHWARZBECK	VULB 9168	9168-360	Apr. 09, 2012	Apr. 08, 2013
Horn_Antenna AISI	AIH.8018	0000320091110	Nov. 19, 2012	Nov. 18, 2013
Horn_Antenna SCHWARZBECK	BBHA 9170	9170-424	Oct. 12, 2012	Oct. 11, 2013
RF Cable	NA	RF104-201 RF104-203 RF104-204	Dec. 25, 2012	Dec. 24, 2013
RF Cable	NA	CHGCAB_001	Oct. 06, 2012	Oct. 05, 2013
Software	ADT_Radiated _V8.7.05	NA	NA	NA
Antenna Tower & Turn Table CT	NA	NA	NA	NA

Note:

1. The calibration interval of the above test instruments is 12 months and the calibrations are traceable to NML/ROC and NIST/USA.
2. The horn antenna, preamplifier (model: 8449B) are used only for the measurement of emission frequency above 1GHz if tested.
- 3 The test was performed in 966 Chamber No. G.
4. The FCC Site Registration No. is 966073.
- 5 The VCCI Site Registration No. is G-137.
- 6 The CANADA Site Registration No. is IC 7450H-2.
- 7 Tested Date: Jan. 04, 2013



A D T

For above 1GHz

DESCRIPTION & MANUFACTURER	MODEL NO.	SERIAL NO.	CALIBRATED DATE	CALIBRATED UNTIL
Spectrum Analyzer Agilent	E4446A	MY48250253	Sep. 03, 2012	Sep. 02, 2013
Pre-Selector Agilent	N9039A	MY46520310	Sep. 03, 2012	Sep. 02, 2013
Signal Generator Agilent	N5181A	MY49060347	July 24, 2012	July 23, 2013
Pre-Amplifier Mini-Circuits	ZFL-1000VH2 B	AMP-ZFL-04	Nov. 14, 2012	Nov. 13, 2013
Pre-Amplifier Agilent	8449B	3008A02465	Feb. 27, 2012	Feb. 26, 2013
SPACEK LABS	SLKKa-48-6	9K16	Nov. 14, 2012	Nov. 13, 2013
Trilog Broadband Antenna SCHWARZBECK	VULB 9168	9168-361	Apr. 06, 2012	Apr. 05, 2013
Horn_Antenna AISI	AIH.8018	0000220091110	Nov. 27, 2012	Nov. 26, 2013
Horn_Antenna SCHWARZBECK	BBHA 9170	9170-424	Oct. 12, 2012	Oct. 11, 2013
RF Cable	NA	RF104-205 RF104-207 RF104-202	Dec. 26, 2012	Dec. 25, 2013
RF Cable	NA	CHHCAB_001	Oct. 07, 2012	Oct. 06, 2013
Software	ADT_Radiated _V8.7.05	NA	NA	NA
Antenna Tower & Turn Table CT	NA	NA	NA	NA

Note:

1. The calibration interval of the above test instruments is 12 months and the calibrations are traceable to NML/ROC and NIST/USA.
2. The horn antenna, preamplifier (model: 8449B) are used only for the measurement of emission frequency above 1GHz if tested.
- 3 The test was performed in 966 Chamber No. H.
4. The FCC Site Registration No. is 797305.
- 5 The CANADA Site Registration No. is IC 7450H-3.
- 6 Tested Date: Jan. 07, 2013

4.2.3 TEST PROCEDURES

- a. The EUT was placed on the top of a rotating table 0.8 meters above the ground at 3 meter chamber room for test. The table was rotated 360 degrees to determine the position of the highest radiation.
- b. The EUT was set 3 meters away from the interference-receiving antenna, which was mounted on the top of a variable-height antenna tower.
- c. The height of antenna is varied from one meter to four meters above the ground to determine the maximum value of the field strength. Both horizontal and vertical polarizations of the antenna are set to make the measurement.
- d. For each suspected emission, the EUT was arranged to its worst case and then the antenna was tuned to heights from 1 meter to 4 meters and the rotatable table was turned from 0 degrees to 360 degrees to find the maximum reading.
- e. The test-receiver system was set to quasi-peak detect function and specified bandwidth with maximum hold mode when the test frequency is below 1 GHz.
- f. The test-receiver system was set to peak and average detect function and specified bandwidth with maximum hold mode when the test frequency is above 1 GHz. If the peak reading value also meets average limit, measurement with the average detector is unnecessary.

NOTE:

1. The resolution bandwidth and video bandwidth of test receiver/spectrum analyzer is 120kHz for Quasi-peak detection (QP) at frequency below 1GHz.
2. The resolution bandwidth of test receiver/spectrum analyzer is 1 MHz and the video bandwidth is 3 MHz for Peak detection (PK) at frequency above 1GHz.
3. The resolution bandwidth of test receiver/spectrum analyzer is 1 MHz and the video bandwidth is 10 Hz for Average detection (AV) at frequency above 1GHz.
4. All modes of operation were investigated and the worst-case emissions are reported.

4.2.4 DEVIATION FROM TEST STANDARD

No deviation

4.2.5 TEST SETUP

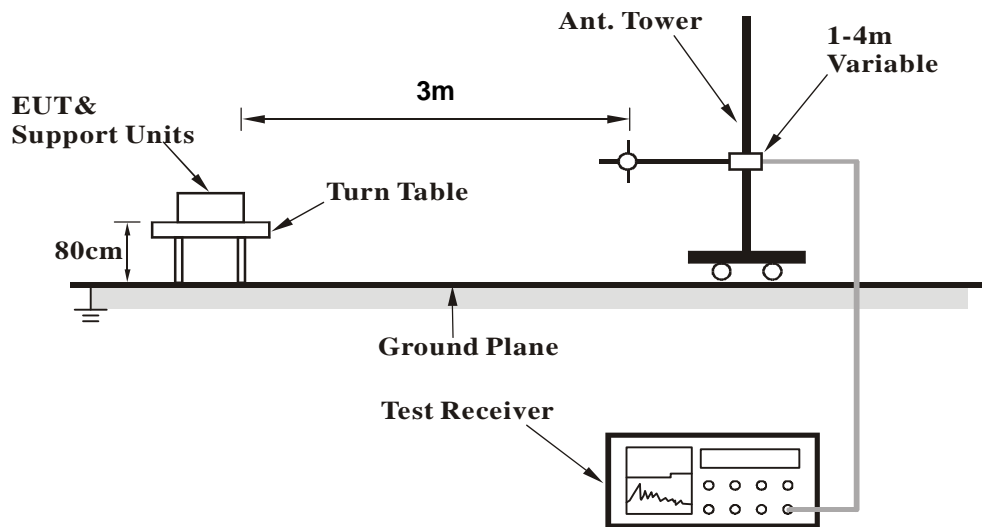

For the actual test configuration, please refer to the related item – Photographs of the Test Configuration.

4.2.6 EUT OPERATING CONDITIONS

Same as 4.1.6

4.2.7 TEST RESULTS

BELOW 1GHz WORST-CASE DATA

802.11b

CHANNEL	TX Channel 6	DETECTOR FUNCTION	Quasi-Peak (QP)
FREQUENCY RANGE	Below 1GHz		

ANTENNA POLARITY & TEST DISTANCE: HORIZONTAL AT 3 M								
NO.	FREQ. (MHz)	EMISSION LEVEL (dBuV/m)	LIMIT (dBuV/m)	MARGIN (dB)	ANTENNA HEIGHT (m)	TABLE ANGLE (Degree)	RAW VALUE (dBuV)	CORRECTION FACTOR (dB/m)
1	75.00	35.4 QP	40.0	-4.6	2.00 H	94	24.24	11.16
2	124.97	37.2 QP	43.5	-6.3	1.50 H	123	24.27	12.91
3	199.46	35.3 QP	43.5	-8.2	1.00 H	216	24.11	11.21
4	250.03	37.1 QP	46.0	-8.9	1.00 H	305	23.76	13.35
5	750.01	34.8 QP	46.0	-11.2	1.00 H	335	9.87	24.91
6	799.98	34.1 QP	46.0	-12.0	1.00 H	333	8.13	25.92
ANTENNA POLARITY & TEST DISTANCE: VERTICAL AT 3 M								
NO.	FREQ. (MHz)	EMISSION LEVEL (dBuV/m)	LIMIT (dBuV/m)	MARGIN (dB)	ANTENNA HEIGHT (m)	TABLE ANGLE (Degree)	RAW VALUE (dBuV)	CORRECTION FACTOR (dB/m)
1	85.30	33.8 QP	40.0	-6.2	2.00 V	0	24.72	9.12
2	124.97	34.3 QP	43.5	-9.3	2.00 V	197	21.34	12.91
3	185.61	36.0 QP	43.5	-7.5	1.00 V	20	23.51	12.46
4	223.74	35.7 QP	46.0	-10.3	1.00 V	351	23.49	12.20
5	250.03	35.3 QP	46.0	-10.7	2.00 V	360	21.98	13.35
6	500.02	36.8 QP	46.0	-9.2	2.00 V	358	16.43	20.39

REMARKS:

1. Emission level (dBuV/m) = Raw Value (dBuV) + Correction Factor (dB/m).
2. Correction Factor (dB/m) = Antenna Factor (dB/m) + Cable Factor (dB).
3. The other emission levels were very low against the limit.
4. Margin value = Emission level – Limit value.



A D T

ABOVE 1GHz DATA

802.11b

CHANNEL	TX Channel 1	DETECTOR FUNCTION	Peak (PK)
FREQUENCY RANGE	1GHz ~ 25GHz		Average (AV)

ANTENNA POLARITY & TEST DISTANCE: HORIZONTAL AT 3 M

NO.	FREQ. (MHz)	EMISSION LEVEL (dBuV/m)	LIMIT (dBuV/m)	MARGIN (dB)	ANTENNA HEIGHT (m)	TABLE ANGLE (Degree)	RAW VALUE (dBuV)	CORRECTION FACTOR (dB/m)
1	2390.00	57.9 PK	74.0	-16.1	1.04 H	288	25.12	32.78
2	2390.00	44.9 AV	54.0	-9.1	1.04 H	288	12.12	32.78
3	*2412.00	99.2 PK			1.04 H	288	66.36	32.84
4	*2412.00	96.4 AV			1.04 H	288	63.56	32.84
5	4824.00	49.9 PK	74.0	-24.1	1.18 H	269	7.63	42.27
6	4824.00	44.4 AV	54.0	-9.6	1.18 H	269	2.13	42.27

ANTENNA POLARITY & TEST DISTANCE: VERTICAL AT 3 M

NO.	FREQ. (MHz)	EMISSION LEVEL (dBuV/m)	LIMIT (dBuV/m)	MARGIN (dB)	ANTENNA HEIGHT (m)	TABLE ANGLE (Degree)	RAW VALUE (dBuV)	CORRECTION FACTOR (dB/m)
1	2390.00	61.3 PK	74.0	-12.7	1.00 V	346	28.52	32.78
2	2390.00	52.6 AV	54.0	-1.4	1.00 V	346	19.82	32.78
3	*2412.00	110.8 PK			1.00 V	346	77.96	32.84
4	*2412.00	108.3 AV			1.00 V	346	75.46	32.84
5	4824.00	51.3 PK	74.0	-22.7	1.00 V	166	9.03	42.27
6	4824.00	46.7 AV	54.0	-7.3	1.00 V	166	4.43	42.27

REMARKS:

1. Emission level (dBuV/m) = Raw Value (dBuV) + Correction Factor (dB/m).
2. Correction Factor (dB/m) = Antenna Factor (dB/m) + Cable Factor (dB).
3. The other emission levels were very low against the limit.
4. Margin value = Emission level – Limit value.
5. " * ": Fundamental frequency.



A D T

CHANNEL	TX Channel 6	DETECTOR FUNCTION	Peak (PK)
FREQUENCY RANGE	1GHz ~ 25GHz		Average (AV)

ANTENNA POLARITY & TEST DISTANCE: HORIZONTAL AT 3 M

NO.	FREQ. (MHz)	EMISSION LEVEL (dBuV/m)	LIMIT (dBuV/m)	MARGIN (dB)	ANTENNA HEIGHT (m)	TABLE ANGLE (Degree)	RAW VALUE (dBuV)	CORRECTION FACTOR (dB/m)
1	2390.00	57.0 PK	74.0	-17.0	1.01 H	289	24.22	32.78
2	2390.00	44.9 AV	54.0	-9.1	1.01 H	289	12.12	32.78
3	*2437.00	103.8 PK			1.01 H	289	70.89	32.91
4	*2437.00	101.3 AV			1.01 H	289	68.39	32.91
5	2483.50	57.3 PK	74.0	-16.7	1.01 H	289	24.27	33.03
6	2483.50	45.1 AV	54.0	-8.9	1.01 H	289	12.07	33.03
7	4874.00	50.1 PK	74.0	-23.9	1.16 H	248	7.78	42.32
8	4874.00	44.3 AV	54.0	-9.7	1.16 H	248	1.98	42.32
9	7311.00	52.4 PK	74.0	-21.6	1.00 H	108	5.45	46.95
10	7311.00	41.2 AV	54.0	-12.8	1.00 H	108	-5.75	46.95

ANTENNA POLARITY & TEST DISTANCE: VERTICAL AT 3 M

NO.	FREQ. (MHz)	EMISSION LEVEL (dBuV/m)	LIMIT (dBuV/m)	MARGIN (dB)	ANTENNA HEIGHT (m)	TABLE ANGLE (Degree)	RAW VALUE (dBuV)	CORRECTION FACTOR (dB/m)
1	2390.00	61.0 PK	74.0	-13.0	1.00 V	346	28.22	32.78
2	2390.00	49.6 AV	54.0	-4.4	1.00 V	346	16.82	32.78
3	*2437.00	115.4 PK			1.00 V	345	82.49	32.91
4	*2437.00	112.6 AV			1.00 V	345	79.69	32.91
5	2483.50	60.8 PK	74.0	-13.2	1.00 V	346	27.77	33.03
6	2483.50	47.0 AV	54.0	-7.0	1.00 V	346	13.97	33.03
7	4874.00	51.1 PK	74.0	-22.9	1.02 V	344	8.78	42.32
8	4874.00	46.7 AV	54.0	-7.3	1.02 V	344	4.38	42.32
9	7311.00	52.3 PK	74.0	-21.7	1.01 V	140	5.35	46.95
10	7311.00	41.3 AV	54.0	-12.7	1.01 V	140	-5.65	46.95

REMARKS:

1. Emission level (dBuV/m) = Raw Value (dBuV) + Correction Factor (dB/m).
2. Correction Factor (dB/m) = Antenna Factor (dB/m) + Cable Factor (dB).
3. The other emission levels were very low against the limit.
4. Margin value = Emission level – Limit value.
5. " * ": Fundamental frequency.



A D T

CHANNEL	TX Channel 11	DETECTOR FUNCTION	Peak (PK)
FREQUENCY RANGE	1GHz ~ 25GHz		Average (AV)

ANTENNA POLARITY & TEST DISTANCE: HORIZONTAL AT 3 M

NO.	FREQ. (MHz)	EMISSION LEVEL (dBuV/m)	LIMIT (dBuV/m)	MARGIN (dB)	ANTENNA HEIGHT (m)	TABLE ANGLE (Degree)	RAW VALUE (dBuV)	CORRECTION FACTOR (dB/m)
1	*2462.00	99.7 PK			1.00 H	291	66.73	32.97
2	*2462.00	97.4 AV			1.00 H	291	64.43	32.97
3	2483.50	57.8 PK	74.0	-16.2	1.00 H	291	24.77	33.03
4	2483.50	46.1 AV	54.0	-7.9	1.00 H	291	13.07	33.03
5	4924.00	50.6 PK	74.0	-23.4	1.17 H	259	8.28	42.32
6	4924.00	44.9 AV	54.0	-9.1	1.17 H	259	2.58	42.32
7	7386.00	52.4 PK	74.0	-21.6	1.00 H	97	5.21	47.19
8	7386.00	41.1 AV	54.0	-12.9	1.00 H	97	-6.09	47.19

ANTENNA POLARITY & TEST DISTANCE: VERTICAL AT 3 M

NO.	FREQ. (MHz)	EMISSION LEVEL (dBuV/m)	LIMIT (dBuV/m)	MARGIN (dB)	ANTENNA HEIGHT (m)	TABLE ANGLE (Degree)	RAW VALUE (dBuV)	CORRECTION FACTOR (dB/m)
1	*2462.00	110.8 PK			1.17 V	337	77.83	32.97
2	*2462.00	108.4 AV			1.17 V	337	75.43	32.97
3	2483.50	63.3 PK	74.0	-10.7	1.16 V	343	30.27	33.03
4	2483.50	53.4 AV	54.0	-0.6	1.16 V	343	20.37	33.03
5	4924.00	50.7 PK	74.0	-23.3	1.00 V	130	8.38	42.32
6	4924.00	46.9 AV	54.0	-7.1	1.00 V	130	4.58	42.32
7	7386.00	52.6 PK	74.0	-21.4	1.09 V	179	5.41	47.19
8	7386.00	41.4 AV	54.0	-12.6	1.09 V	179	-5.79	47.19

REMARKS:

1. Emission level (dBuV/m) = Raw Value (dBuV) + Correction Factor (dB/m).
2. Correction Factor (dB/m) = Antenna Factor (dB/m) + Cable Factor (dB).
3. The other emission levels were very low against the limit.
4. Margin value = Emission level – Limit value.
5. " * " : Fundamental frequency.



A D T

802.11g

CHANNEL	TX Channel 1	DETECTOR FUNCTION	Peak (PK)
FREQUENCY RANGE	1GHz ~ 25GHz		Average (AV)

ANTENNA POLARITY & TEST DISTANCE: HORIZONTAL AT 3 M

NO.	FREQ. (MHz)	EMISSION LEVEL (dBuV/m)	LIMIT (dBuV/m)	MARGIN (dB)	ANTENNA HEIGHT (m)	TABLE ANGLE (Degree)	RAW VALUE (dBuV)	CORRECTION FACTOR (dB/m)
1	2390.00	58.3 PK	74.0	-15.7	1.04 H	288	25.52	32.78
2	2390.00	46.1 AV	54.0	-7.9	1.04 H	288	13.32	32.78
3	*2412.00	100.1 PK			1.04 H	288	67.26	32.84
4	*2412.00	89.7 AV			1.04 H	288	56.86	32.84
5	4824.00	47.3 PK	74.0	-26.7	1.00 H	12	5.03	42.27
6	4824.00	36.3 AV	54.0	-17.7	1.00 H	12	-5.97	42.27

ANTENNA POLARITY & TEST DISTANCE: VERTICAL AT 3 M

NO.	FREQ. (MHz)	EMISSION LEVEL (dBuV/m)	LIMIT (dBuV/m)	MARGIN (dB)	ANTENNA HEIGHT (m)	TABLE ANGLE (Degree)	RAW VALUE (dBuV)	CORRECTION FACTOR (dB/m)
1	2390.00	66.4 PK	74.0	-7.6	1.00 V	345	33.62	32.78
2	2390.00	53.1 AV	54.0	-0.9	1.00 V	345	20.32	32.78
3	*2412.00	112.4 PK			1.00 V	345	79.56	32.84
4	*2412.00	100.2 AV			1.00 V	345	67.36	32.84
5	4824.00	48.3 PK	74.0	-25.7	1.00 V	153	6.03	42.27
6	4824.00	36.2 AV	54.0	-17.8	1.00 V	153	-6.07	42.27

REMARKS:

1. Emission level (dBuV/m) = Raw Value (dBuV) + Correction Factor (dB/m).
2. Correction Factor (dB/m) = Antenna Factor (dB/m) + Cable Factor (dB).
3. The other emission levels were very low against the limit.
4. Margin value = Emission level – Limit value.
5. " * ": Fundamental frequency.



A D T

CHANNEL	TX Channel 6	DETECTOR FUNCTION	Peak (PK)
FREQUENCY RANGE	1GHz ~ 25GHz		Average (AV)

ANTENNA POLARITY & TEST DISTANCE: HORIZONTAL AT 3 M

NO.	FREQ. (MHz)	EMISSION LEVEL (dBuV/m)	LIMIT (dBuV/m)	MARGIN (dB)	ANTENNA HEIGHT (m)	TABLE ANGLE (Degree)	RAW VALUE (dBuV)	CORRECTION FACTOR (dB/m)
1	2390.00	56.5 PK	74.0	-17.5	1.01 H	290	23.72	32.78
2	2390.00	45.1 AV	54.0	-8.9	1.01 H	290	12.32	32.78
3	*2437.00	106.7 PK			1.01 H	290	73.79	32.91
4	*2437.00	95.8 AV			1.01 H	290	62.89	32.91
5	2483.50	57.5 PK	74.0	-16.5	1.01 H	290	24.47	33.03
6	2483.50	44.9 AV	54.0	-9.1	1.01 H	290	11.87	33.03
7	4874.00	47.6 PK	74.0	-26.4	1.00 H	15	5.28	42.32
8	4874.00	36.5 AV	54.0	-17.5	1.00 H	15	-5.82	42.32
9	7311.00	55.5 PK	74.0	-18.5	1.00 H	251	8.55	46.95
10	7311.00	44.2 AV	54.0	-9.8	1.00 H	251	-2.75	46.95

ANTENNA POLARITY & TEST DISTANCE: VERTICAL AT 3 M

NO.	FREQ. (MHz)	EMISSION LEVEL (dBuV/m)	LIMIT (dBuV/m)	MARGIN (dB)	ANTENNA HEIGHT (m)	TABLE ANGLE (Degree)	RAW VALUE (dBuV)	CORRECTION FACTOR (dB/m)
1	2390.00	66.5 PK	74.0	-7.5	1.00 V	347	33.72	32.78
2	2390.00	50.3 AV	54.0	-3.7	1.00 V	347	17.52	32.78
3	*2437.00	118.4 PK			1.00 V	347	85.49	32.91
4	*2437.00	106.3 AV			1.00 V	347	73.39	32.91
5	2483.50	67.8 PK	74.0	-6.2	1.15 V	339	34.77	33.03
6	2483.50	49.5 AV	54.0	-4.5	1.15 V	339	16.47	33.03
7	4874.00	48.1 PK	74.0	-25.9	1.00 V	155	5.78	42.32
8	4874.00	36.3 AV	54.0	-17.7	1.00 V	155	-6.02	42.32
9	7311.00	56.1 PK	74.0	-17.9	1.00 V	213	9.15	46.95
10	7311.00	44.1 AV	54.0	-9.9	1.00 V	213	-2.85	46.95

REMARKS:

1. Emission level (dBuV/m) = Raw Value (dBuV) + Correction Factor (dB/m).
2. Correction Factor (dB/m) = Antenna Factor (dB/m) + Cable Factor (dB).
3. The other emission levels were very low against the limit.
4. Margin value = Emission level – Limit value.
5. " * ": Fundamental frequency.



A D T

CHANNEL	TX Channel 11	DETECTOR FUNCTION	Peak (PK)
FREQUENCY RANGE	1GHz ~ 25GHz		Average (AV)

ANTENNA POLARITY & TEST DISTANCE: HORIZONTAL AT 3 M

NO.	FREQ. (MHz)	EMISSION LEVEL (dBuV/m)	LIMIT (dBuV/m)	MARGIN (dB)	ANTENNA HEIGHT (m)	TABLE ANGLE (Degree)	RAW VALUE (dBuV)	CORRECTION FACTOR (dB/m)
1	*2462.00	100.1 PK			1.00 H	285	67.13	32.97
2	*2462.00	89.6 AV			1.00 H	285	56.63	32.97
3	2483.50	58.0 PK	74.0	-16.0	1.00 H	285	24.97	33.03
4	2483.50	46.2 AV	54.0	-7.8	1.00 H	285	13.17	33.03
5	4924.00	48.2 PK	74.0	-25.8	1.00 H	14	5.88	42.32
6	4924.00	36.3 AV	54.0	-17.7	1.00 H	14	-6.02	42.32
7	7386.00	55.3 PK	74.0	-18.7	1.00 H	251	8.11	47.19
8	7386.00	44.1 AV	54.0	-9.9	1.00 H	251	-3.09	47.19

ANTENNA POLARITY & TEST DISTANCE: VERTICAL AT 3 M

NO.	FREQ. (MHz)	EMISSION LEVEL (dBuV/m)	LIMIT (dBuV/m)	MARGIN (dB)	ANTENNA HEIGHT (m)	TABLE ANGLE (Degree)	RAW VALUE (dBuV)	CORRECTION FACTOR (dB/m)
1	*2462.00	112.3 PK			1.16 V	340	79.33	32.97
2	*2462.00	100.5 AV			1.16 V	340	67.53	32.97
3	2483.50	68.3 PK	74.0	-5.7	1.16 V	336	35.27	33.03
4	2483.50	53.3 AV	54.0	-0.7	1.16 V	336	20.27	33.03
5	4924.00	48.5 PK	74.0	-25.5	1.00 V	151	6.18	42.32
6	4924.00	36.3 AV	54.0	-17.7	1.00 V	151	-6.02	42.32
7	7386.00	56.3 PK	74.0	-17.7	1.00 V	221	9.11	47.19
8	7386.00	44.3 AV	54.0	-9.7	1.00 V	221	-2.89	47.19

REMARKS:

1. Emission level (dBuV/m) = Raw Value (dBuV) + Correction Factor (dB/m).
2. Correction Factor (dB/m) = Antenna Factor (dB/m) + Cable Factor (dB).
3. The other emission levels were very low against the limit.
4. Margin value = Emission level – Limit value.
5. " * " : Fundamental frequency.



A D T

802.11n (HT20)

CHANNEL	TX Channel 1	DETECTOR FUNCTION	Peak (PK)
FREQUENCY RANGE	1GHz ~ 25GHz		Average (AV)

ANTENNA POLARITY & TEST DISTANCE: HORIZONTAL AT 3 M								
NO.	FREQ. (MHz)	EMISSION LEVEL (dBuV/m)	LIMIT (dBuV/m)	MARGIN (dB)	ANTENNA HEIGHT (m)	TABLE ANGLE (Degree)	RAW VALUE (dBuV)	CORRECTION FACTOR (dB/m)
1	2390.00	57.6 PK	74.0	-16.4	1.00 H	150	24.82	32.78
2	2390.00	46.6 AV	54.0	-7.4	1.00 H	150	13.82	32.78
3	*2412.00	100.8 PK			1.00 H	150	67.96	32.84
4	*2412.00	90.3 AV			1.00 H	150	57.46	32.84
5	4824.00	48.8 PK	74.0	-25.2	1.00 H	13	6.53	42.27
6	4824.00	36.1 AV	54.0	-17.9	1.00 H	13	-6.17	42.27
ANTENNA POLARITY & TEST DISTANCE: VERTICAL AT 3 M								
NO.	FREQ. (MHz)	EMISSION LEVEL (dBuV/m)	LIMIT (dBuV/m)	MARGIN (dB)	ANTENNA HEIGHT (m)	TABLE ANGLE (Degree)	RAW VALUE (dBuV)	CORRECTION FACTOR (dB/m)
1	2390.00	69.8 PK	74.0	-4.2	1.00 V	216	37.02	32.78
2	2390.00	53.2 AV	54.0	-0.8	1.00 V	216	20.42	32.78
3	*2412.00	112.9 PK			1.00 V	215	80.06	32.84
4	*2412.00	101.6 AV			1.00 V	215	68.76	32.84
5	4824.00	49.1 PK	74.0	-24.9	1.00 V	153	6.83	42.27
6	4824.00	36.3 AV	54.0	-17.7	1.00 V	153	-5.97	42.27

REMARKS:

1. Emission level (dBuV/m) = Raw Value (dBuV) + Correction Factor (dB/m).
2. Correction Factor (dB/m) = Antenna Factor (dB/m) + Cable Factor (dB).
3. The other emission levels were very low against the limit.
4. Margin value = Emission level – Limit value.
5. " * ": Fundamental frequency.



A D T

CHANNEL	TX Channel 6	DETECTOR FUNCTION	Peak (PK)
FREQUENCY RANGE	1GHz ~ 25GHz		Average (AV)

ANTENNA POLARITY & TEST DISTANCE: HORIZONTAL AT 3 M

NO.	FREQ. (MHz)	EMISSION LEVEL (dBuV/m)	LIMIT (dBuV/m)	MARGIN (dB)	ANTENNA HEIGHT (m)	TABLE ANGLE (Degree)	RAW VALUE (dBuV)	CORRECTION FACTOR (dB/m)
1	2390.00	56.6 PK	74.0	-17.4	1.00 H	288	23.82	32.78
2	2390.00	44.9 AV	54.0	-9.1	1.00 H	288	12.12	32.78
3	*2437.00	108.0 PK			1.00 H	288	75.09	32.91
4	*2437.00	94.1 AV			1.00 H	288	61.19	32.91
5	2483.50	57.5 PK	74.0	-16.5	1.00 H	288	24.47	33.03
6	2483.50	45.1 AV	54.0	-8.9	1.00 H	288	12.07	33.03
7	4874.00	49.1 PK	74.0	-24.9	1.00 H	10	6.78	42.32
8	4874.00	36.3 AV	54.0	-17.7	1.00 H	10	-6.02	42.32
9	7311.00	55.6 PK	74.0	-18.4	1.00 H	253	8.65	46.95
10	7311.00	44.3 AV	54.0	-9.7	1.00 H	253	-2.65	46.95

ANTENNA POLARITY & TEST DISTANCE: VERTICAL AT 3 M

NO.	FREQ. (MHz)	EMISSION LEVEL (dBuV/m)	LIMIT (dBuV/m)	MARGIN (dB)	ANTENNA HEIGHT (m)	TABLE ANGLE (Degree)	RAW VALUE (dBuV)	CORRECTION FACTOR (dB/m)
1	2390.00	71.2 PK	74.0	-2.8	1.00 V	350	38.42	32.78
2	2390.00	51.5 AV	54.0	-2.5	1.00 V	350	18.72	32.78
3	*2437.00	116.5 PK			1.00 V	350	83.59	32.91
4	*2437.00	105.3 AV			1.00 V	350	72.39	32.91
5	2483.50	71.5 PK	74.0	-2.5	1.38 V	348	38.47	33.03
6	2483.50	51.9 AV	54.0	-2.1	1.38 V	348	18.87	33.03
7	4874.00	50.1 PK	74.0	-23.9	1.00 V	153	7.78	42.32
8	4874.00	37.4 AV	54.0	-16.6	1.00 V	153	-4.92	42.32
9	7311.00	56.1 PK	74.0	-17.9	1.00 V	222	9.15	46.95
10	7311.00	44.2 AV	54.0	-9.8	1.00 V	222	-2.75	46.95

REMARKS:

1. Emission level (dBuV/m) = Raw Value (dBuV) + Correction Factor (dB/m).
2. Correction Factor (dB/m) = Antenna Factor (dB/m) + Cable Factor (dB).
3. The other emission levels were very low against the limit.
4. Margin value = Emission level – Limit value.
5. " * ": Fundamental frequency.



A D T

CHANNEL	TX Channel 11	DETECTOR FUNCTION	Peak (PK)
FREQUENCY RANGE	1GHz ~ 25GHz		Average (AV)

ANTENNA POLARITY & TEST DISTANCE: HORIZONTAL AT 3 M

NO.	FREQ. (MHz)	EMISSION LEVEL (dBuV/m)	LIMIT (dBuV/m)	MARGIN (dB)	ANTENNA HEIGHT (m)	TABLE ANGLE (Degree)	RAW VALUE (dBuV)	CORRECTION FACTOR (dB/m)
1	*2462.00	99.2 PK			1.00 H	287	66.23	32.97
2	*2462.00	88.4 AV			1.00 H	287	55.43	32.97
3	2483.50	58.6 PK	74.0	-15.4	1.00 H	287	25.57	33.03
4	2483.50	45.3 AV	54.0	-8.7	1.00 H	287	12.27	33.03
5	4924.00	48.6 PK	74.0	-25.4	1.00 H	15	6.28	42.32
6	4924.00	36.2 AV	54.0	-17.8	1.00 H	15	-6.12	42.32
7	7386.00	55.3 PK	74.0	-18.7	1.00 H	251	8.11	47.19
8	7386.00	44.2 AV	54.0	-9.8	1.00 H	251	-2.99	47.19

ANTENNA POLARITY & TEST DISTANCE: VERTICAL AT 3 M

NO.	FREQ. (MHz)	EMISSION LEVEL (dBuV/m)	LIMIT (dBuV/m)	MARGIN (dB)	ANTENNA HEIGHT (m)	TABLE ANGLE (Degree)	RAW VALUE (dBuV)	CORRECTION FACTOR (dB/m)
1	*2462.00	110.3 PK			1.14 V	208	77.33	32.97
2	*2462.00	99.8 AV			1.14 V	208	66.83	32.97
3	2483.50	70.3 PK	74.0	-3.7	1.14 V	208	37.27	33.03
4	2483.50	53.5 AV	54.0	-0.5	1.14 V	208	20.47	33.03
5	4924.00	49.6 PK	74.0	-24.4	1.00 V	151	7.28	42.32
6	4924.00	36.5 AV	54.0	-17.5	1.00 V	151	-5.82	42.32
7	7386.00	56.3 PK	74.0	-17.7	1.00 V	224	9.11	47.19
8	7386.00	44.3 AV	54.0	-9.7	1.00 V	224	-2.89	47.19

REMARKS:

1. Emission level (dBuV/m) = Raw Value (dBuV) + Correction Factor (dB/m).
2. Correction Factor (dB/m) = Antenna Factor (dB/m) + Cable Factor (dB).
3. The other emission levels were very low against the limit.
4. Margin value = Emission level – Limit value.
5. " * " : Fundamental frequency.



A D T

802.11n (HT40)

CHANNEL	TX Channel 3	DETECTOR FUNCTION	Peak (PK)
FREQUENCY RANGE	1GHz ~ 25GHz		Average (AV)

ANTENNA POLARITY & TEST DISTANCE: HORIZONTAL AT 3 M

NO.	FREQ. (MHz)	EMISSION LEVEL (dBuV/m)	LIMIT (dBuV/m)	MARGIN (dB)	ANTENNA HEIGHT (m)	TABLE ANGLE (Degree)	RAW VALUE (dBuV)	CORRECTION FACTOR (dB/m)
1	2390.00	56.6 PK	74.0	-17.4	1.01 H	283	23.82	32.78
2	2390.00	44.9 AV	54.0	-9.1	1.01 H	283	12.12	32.78
3	*2422.00	93.7 PK			1.01 H	283	60.83	32.87
4	*2422.00	83.6 AV			1.01 H	283	50.73	32.87
5	4844.00	48.1 PK	74.0	-25.9	1.00 H	20	5.81	42.29
6	4844.00	36.3 AV	54.0	-17.7	1.00 H	20	-5.99	42.29
7	7266.00	55.4 PK	74.0	-18.6	1.00 H	253	8.59	46.81
8	7266.00	44.2 AV	54.0	-9.8	1.00 H	253	-2.61	46.81

ANTENNA POLARITY & TEST DISTANCE: VERTICAL AT 3 M

NO.	FREQ. (MHz)	EMISSION LEVEL (dBuV/m)	LIMIT (dBuV/m)	MARGIN (dB)	ANTENNA HEIGHT (m)	TABLE ANGLE (Degree)	RAW VALUE (dBuV)	CORRECTION FACTOR (dB/m)
1	2390.00	69.8 PK	74.0	-4.2	1.17 V	217	37.02	32.78
2	2390.00	53.4 AV	54.0	-0.6	1.17 V	217	20.62	32.78
3	*2422.00	107.4 PK			1.17 V	217	74.53	32.87
4	*2422.00	95.0 AV			1.17 V	217	62.13	32.87
5	4844.00	49.5 PK	74.0	-24.5	1.00 V	153	7.21	42.29
6	4844.00	36.3 AV	54.0	-17.7	1.00 V	153	-5.99	42.29
7	7266.00	56.1 PK	74.0	-17.9	1.00 V	223	9.29	46.81
8	7266.00	44.3 AV	54.0	-9.7	1.00 V	223	-2.51	46.81

REMARKS:

1. Emission level (dBuV/m) = Raw Value (dBuV) + Correction Factor (dB/m).
2. Correction Factor (dB/m) = Antenna Factor (dB/m) + Cable Factor (dB).
3. The other emission levels were very low against the limit.
4. Margin value = Emission level – Limit value.
5. " * ": Fundamental frequency.



A D T

CHANNEL	TX Channel 6	DETECTOR FUNCTION	Peak (PK)
FREQUENCY RANGE	1GHz ~ 25GHz		Average (AV)

ANTENNA POLARITY & TEST DISTANCE: HORIZONTAL AT 3 M

NO.	FREQ. (MHz)	EMISSION LEVEL (dBuV/m)	LIMIT (dBuV/m)	MARGIN (dB)	ANTENNA HEIGHT (m)	TABLE ANGLE (Degree)	RAW VALUE (dBuV)	CORRECTION FACTOR (dB/m)
1	2390.00	57.7 PK	74.0	-16.3	1.00 H	290	24.92	32.78
2	2390.00	44.8 AV	54.0	-9.2	1.00 H	290	12.02	32.78
3	*2437.00	98.4 PK			1.00 H	290	65.49	32.91
4	*2437.00	87.6 AV			1.00 H	290	54.69	32.91
5	2483.50	56.9 PK	74.0	-17.1	1.00 H	290	23.87	33.03
6	2483.50	45.1 AV	54.0	-8.9	1.00 H	290	12.07	33.03
7	4874.00	47.9 PK	74.0	-26.1	1.00 H	21	5.58	42.32
8	4874.00	36.4 AV	54.0	-17.6	1.00 H	21	-5.92	42.32
9	7311.00	55.7 PK	74.0	-18.3	1.00 H	251	8.75	46.95
10	7311.00	44.3 AV	54.0	-9.7	1.00 H	251	-2.65	46.95

ANTENNA POLARITY & TEST DISTANCE: VERTICAL AT 3 M

NO.	FREQ. (MHz)	EMISSION LEVEL (dBuV/m)	LIMIT (dBuV/m)	MARGIN (dB)	ANTENNA HEIGHT (m)	TABLE ANGLE (Degree)	RAW VALUE (dBuV)	CORRECTION FACTOR (dB/m)
1	2390.00	66.7 PK	74.0	-7.3	1.00 V	330	33.92	32.78
2	2390.00	53.0 AV	54.0	-1.0	1.00 V	330	20.22	32.78
3	*2437.00	112.3 PK			1.31 V	224	79.39	32.91
4	*2437.00	99.6 AV			1.31 V	224	66.69	32.91
5	2483.50	63.8 PK	74.0	-10.2	1.31 V	224	30.77	33.03
6	2483.50	51.4 AV	54.0	-2.6	1.31 V	224	18.37	33.03
7	4874.00	55.9 PK	74.0	-18.1	1.00 V	147	13.58	42.32
8	4874.00	36.6 AV	54.0	-17.4	1.00 V	147	-5.72	42.32
9	7311.00	56.5 PK	74.0	-17.5	1.00 V	219	9.55	46.95
10	7311.00	44.1 AV	54.0	-9.9	1.00 V	219	-2.85	46.95

REMARKS:

1. Emission level (dBuV/m) = Raw Value (dBuV) + Correction Factor (dB/m).
2. Correction Factor (dB/m) = Antenna Factor (dB/m) + Cable Factor (dB).
3. The other emission levels were very low against the limit.
4. Margin value = Emission level – Limit value.
5. " * ": Fundamental frequency.



A D T

CHANNEL	TX Channel 9	DETECTOR FUNCTION	Peak (PK)
FREQUENCY RANGE	1GHz ~ 25GHz		Average (AV)

ANTENNA POLARITY & TEST DISTANCE: HORIZONTAL AT 3 M

NO.	FREQ. (MHz)	EMISSION LEVEL (dBuV/m)	LIMIT (dBuV/m)	MARGIN (dB)	ANTENNA HEIGHT (m)	TABLE ANGLE (Degree)	RAW VALUE (dBuV)	CORRECTION FACTOR (dB/m)
1	*2452.00	94.3 PK			1.00 H	289	61.35	32.95
2	*2452.00	82.7 AV			1.00 H	289	49.75	32.95
3	2483.50	57.3 PK	74.0	-16.7	1.00 H	289	24.27	33.03
4	2483.50	45.7 AV	54.0	-8.3	1.00 H	289	12.67	33.03
5	4904.00	48.6 PK	74.0	-25.4	1.00 H	18	6.26	42.34
6	4904.00	36.5 AV	54.0	-17.5	1.00 H	18	-5.84	42.34
7	7356.00	55.6 PK	74.0	-18.4	1.00 H	249	8.51	47.09
8	7356.00	44.1 AV	54.0	-9.9	1.00 H	249	-2.99	47.09

ANTENNA POLARITY & TEST DISTANCE: VERTICAL AT 3 M

NO.	FREQ. (MHz)	EMISSION LEVEL (dBuV/m)	LIMIT (dBuV/m)	MARGIN (dB)	ANTENNA HEIGHT (m)	TABLE ANGLE (Degree)	RAW VALUE (dBuV)	CORRECTION FACTOR (dB/m)
1	*2452.00	107.0 PK			1.14 V	329	74.05	32.95
2	*2452.00	94.7 AV			1.14 V	329	61.75	32.95
3	2483.50	69.9 PK	74.0	-4.1	1.14 V	329	36.87	33.03
4	2483.50	53.5 AV	54.0	-0.5	1.14 V	329	20.47	33.03
5	4904.00	55.3 PK	74.0	-18.7	1.00 V	149	12.96	42.34
6	4904.00	36.5 AV	54.0	-17.5	1.00 V	149	-5.84	42.34
7	7356.00	56.5 PK	74.0	-17.5	1.00 V	221	9.41	47.09
8	7356.00	44.3 AV	54.0	-9.7	1.00 V	221	-2.79	47.09

REMARKS:

1. Emission level (dBuV/m) = Raw Value (dBuV) + Correction Factor (dB/m).
2. Correction Factor (dB/m) = Antenna Factor (dB/m) + Cable Factor (dB).
3. The other emission levels were very low against the limit.
4. Margin value = Emission level – Limit value.
5. " * ": Fundamental frequency.



A D T

4.3 6dB BANDWIDTH MEASUREMENT

4.3.1 LIMITS OF 6dB BANDWIDTH MEASUREMENT

The minimum of 6dB Bandwidth Measurement is 0.5 MHz.

4.3.2 TEST INSTRUMENTS

DESCRIPTION & MANUFACTURER	MODEL NO.	SERIAL NO.	CALIBRATED DATE	CALIBRATED UNTIL
R&S SPECTRUM ANALYZER	FSP40	100037	Nov. 01, 2012	Oct. 31, 2013

Note:

1. The calibration interval of the above test instruments is 12 months and the calibrations are traceable to NML/ROC and NIST/USA.
2. Tested date : Jan. 11, 2013

4.3.3 TEST PROCEDURE

1. Set resolution bandwidth (RBW) = approximately 1% of the emission bandwidth
2. Set the video bandwidth (VBW) $\geq 3 \times$ RBW, Detector = Peak.
3. Trace mode = max hold.
4. Sweep = auto couple.
5. Measure the maximum width of the emission that is constrained by the frequencies associated with the two amplitude points (upper and lower) that are attenuated by 6 dB relative to the maximum level measured in the fundamental emission

4.3.4 DEVIATION FROM TEST STANDARD

No deviation

4.3.5 TEST SETUP

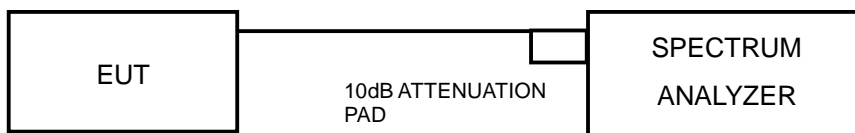

4.3.6 EUT OPERATING CONDITIONS

The software provided by client to enable the EUT under transmission condition continuously at lowest, middle and highest channel frequencies individually.



A D T

4.3.7 TEST RESULTS

802.11b

CHANNEL	FREQUENCY (MHz)	6dB BANDWIDTH (MHz)	MINIMUM LIMIT (MHz)	PASS / FAIL
1	2412	10.89	0.5	PASS
6	2437	9.68	0.5	PASS
11	2462	10.20	0.5	PASS

802.11g

CHANNEL	FREQUENCY (MHz)	6dB BANDWIDTH (MHz)	MINIMUM LIMIT (MHz)	PASS / FAIL
1	2412	16.63	0.5	PASS
6	2437	16.61	0.5	PASS
11	2462	16.63	0.5	PASS

802.11n (HT20)

CHANNEL	CHANNEL FREQUENCY (MHz)	6dB BANDWIDTH (MHz)		MINIMUM LIMIT (MHz)	PASS / FAIL
		CHAIN 0	CHAIN 1		
1	2412	17.87	17.83	0.5	PASS
6	2437	17.85	17.81	0.5	PASS
11	2462	17.87	17.83	0.5	PASS

802.11n (HT40)

CHANNEL	CHANNEL FREQUENCY (MHz)	6dB BANDWIDTH (MHz)		MINIMUM LIMIT (MHz)	PASS / FAIL
		CHAIN 0	CHAIN 1		
3	2422	36.61	36.58	0.5	PASS
6	2437	36.64	36.59	0.5	PASS
9	2452	36.65	36.65	0.5	PASS

4.4 CONDUCTED OUTPUT POWER MEASUREMENT

4.4.1 LIMITS OF MAXIMUM PEAK OUTPUT POWER MEASUREMENT

For systems using digital modulation in the 2400–2483.5 MHz band: 1 Watt (30dBm)

Per KDB 662911 D01 Multiple Transmitter Output v01r02 Method of conducted output power measurement on IEEE 802.11 devices,

- Array Gain = 0 dB (i.e., no array gain) for NANT \leq 4;
- Array Gain = 0 dB (i.e., no array gain) for channel widths \geq 40 MHz for any NANT;
- Array Gain = $5 \log(\text{NANT}/\text{NSS})$ dB or 3 dB, whichever is less for 20-MHz channel widths with NANT \geq 5.

For power measurements on all other devices: Array Gain = $10 \log(\text{NANT}/\text{NSS})$ dB.

4.4.2 INSTRUMENTS

DESCRIPTION & MANUFACTURER	MODEL NO.	SERIAL NO.	CALIBRATED DATE	CALIBRATED UNTIL
Power Meter	ML2495A	0824006	May 10, 2012	May 09, 2013
Power Sensor	MA2411B	0738172	May 10, 2012	May 09, 2013

- Note:**
1. The calibration interval of the above test instruments is 12 months and the calibrations are traceable to NML/ROC and NIST/USA.
 2. Tested date : Jan. 11, 2013

4.4.3 TEST PROCEDURES

A average power sensor was used on the output port of the EUT. A power meter was used to read the response of the average power sensor. Record the average power level.

4.4.4 DEVIATION FROM TEST STANDARD

No deviation.

4.4.5 TEST SETUP

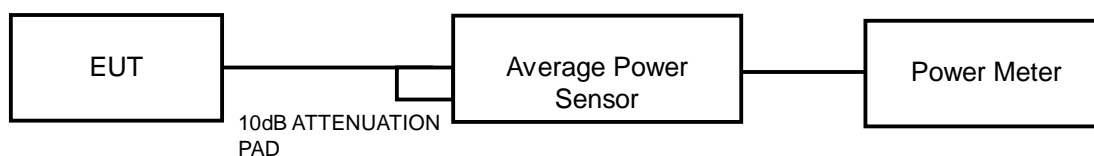

4.4.6 EUT OPERATING CONDITIONS

Same as Item 4.3.6



A D T

4.4.7 TEST RESULTS

802.11b

CHANNEL	FREQUENCY (MHz)	AVERAGE POWER (mW)	AVERAGE POWER (dBm)	LIMIT (dBm)	PASS/FAIL
1	2412	54.954	17.40	30	PASS
6	2437	147.911	21.70	30	PASS
11	2462	60.256	17.80	30	PASS

802.11g

CHANNEL	FREQUENCY (MHz)	AVERAGE POWER (mW)	AVERAGE POWER (dBm)	LIMIT (dBm)	PASS/FAIL
1	2412	38.905	15.90	30	PASS
6	2437	141.254	21.50	30	PASS
11	2462	33.884	15.30	30	PASS

802.11n (HT20)

CHAN.	FREQUENCY (MHz)	AVERAGE POWER (dBm)		TOTAL POWER (mW)	TOTAL POWER (dBm)	LIMIT (dBm)	PASS / FAIL
		CHAIN 0	CHAIN 1				
1	2412	13.30	13.70	44.822	16.51	30	PASS
6	2437	17.90	18.30	129.268	21.11	30	PASS
11	2462	12.10	12.30	33.200	15.21	30	PASS

802.11n (HT40)

CHAN.	FREQUENCY (MHz)	AVERAGE POWER (dBm)		TOTAL POWER (mW)	TOTAL POWER (dBm)	LIMIT (dBm)	PASS / FAIL
		CHAIN 0	CHAIN 1				
3	2422	10.50	11.00	23.809	13.77	30	PASS
6	2437	14.60	15.00	60.463	17.81	30	PASS
9	2452	9.70	9.90	19.105	12.81	30	PASS

4.5 POWER SPECTRAL DENSITY MEASUREMENT

4.5.1 LIMITS OF POWER SPECTRAL DENSITY MEASUREMENT

The Maximum of Power Spectral Density Measurement is 8dBm.

4.5.2 TEST INSTRUMENTS

DESCRIPTION & MANUFACTURER	MODEL NO.	SERIAL NO.	CALIBRATED DATE	CALIBRATED UNTIL
R&S Spectrum Analyzer	FSP40	100037	Nov. 01, 2012	Oct. 31, 2013

Note:

1. The calibration interval of the above test instruments is 12 months and the calibrations are traceable to NML/ROC and NIST/USA.
2. Tested date : Jan. 11, 2013

4.5.3 TEST PROCEDURE

1. Set the RBW = 3 kHz, VBW =10 kHz, Detector = power averaging (RMS) .
2. Ensure that the number of measurement points in the sweep $\geq 2 \times$ span/RBW
3. Sweep time = auto couple,
4. Employ trace averaging (RMS) mode over a minimum of 100 traces.
5. Use the peak marker function to determine the maximum amplitude level.

4.5.4 DEVIATION FROM TEST STANDARD

No deviation

4.5.5 TEST SETUP

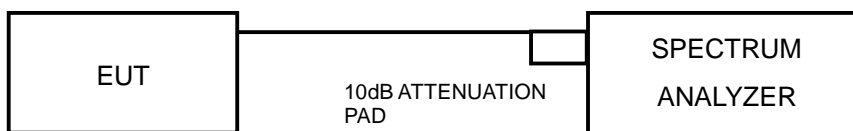

4.5.6 EUT OPERATING CONDITION

Same as Item 4.3.6



A D T

4.5.7 TEST RESULTS

802.11b

Channel	FREQUENCY (MHz)	PSD (dBm/3kHz)	Limit (dBm/3kHz)	PASS /FAIL
1	2412	-7.34	8	PASS
6	2437	-2.86	8	PASS
11	2462	-7.38	8	PASS

802.11g

Channel	FREQUENCY (MHz)	PSD (dBm/3kHz)	Limit (dBm/3kHz)	PASS /FAIL
1	2412	-10.03	8	PASS
6	2437	-4.25	8	PASS
11	2462	-11.13	8	PASS

802.11n (HT20)

TX chain	Channel	FREQ. (MHz)	PSD (dBm/3kHz)	10 log (N=2) dB	Total PSD (dBm/3kHz)	Limit (dBm/3kHz)	PASS /FAIL
0	1	2412	-13.49	3.01	-10.48	8	PASS
	6	2437	-8.11	3.01	-5.10	8	PASS
	11	2462	-14.99	3.01	-11.98	8	PASS
1	1	2412	-13.08	3.01	-10.07	8	PASS
	6	2437	-7.78	3.01	-4.77	8	PASS
	11	2462	-14.50	3.01	-11.49	8	PASS

NOTE: Directional gain = $10 \log[(10^{G1/20} + 10^{G2/20})^2 / 2] = 4.19\text{dBi} < 6\text{dBi}$, so the power density limit shall not be reduced.

802.11n (HT40)

TX chain	Channel	FREQ. (MHz)	PSD (dBm/3kHz)	10 log (N=2) dB	Total PSD (dBm/3kHz)	Limit (dBm/3kHz)	PASS /FAIL
0	3	2422	-19.30	3.01	-16.29	8	PASS
	6	2437	-14.79	3.01	-11.78	8	PASS
	9	2452	-19.78	3.01	-16.77	8	PASS
1	3	2422	-19.07	3.01	-16.06	8	PASS
	6	2437	-13.71	3.01	-10.70	8	PASS
	9	2452	-20.16	3.01	-17.15	8	PASS

NOTE: Directional gain = $10 \log[(10^{G1/20} + 10^{G2/20})^2 / 2] = 4.19\text{dBi} < 6\text{dBi}$, so the power density limit shall not be reduced.



A D T

4.6 CONDUCTED OUT-BAND EMISSION MEASUREMENT

4.6.1 LIMITS OF CONDUCTED OUT-BAND EMISSION MEASUREMENT

Below 30dB of the highest emission level of operating band (in 100kHz Resolution Bandwidth).

4.6.2 TEST INSTRUMENTS

DESCRIPTION & MANUFACTURER	MODEL NO.	SERIAL NO.	CALIBRATED DATE	CALIBRATED UNTIL
R&S Spectrum Analyzer	FSP40	100037	Nov. 01, 2012	Oct. 31, 2013

Note:

1. The calibration interval of the above test instruments is 12 months and the calibrations are traceable to NML/ROC and NIST/USA.
2. Tested date : Jan. 11, 2013

4.6.3 TEST PROCEDURE

Measurement Procedure - Reference Level

1. Set the RBW = 100 kHz.
2. Set the VBW \geq 300 kHz.
3. Detector = power average (RMS).
4. Manually set the sweep time to: $\geq 10 \times$ (number of measurement points in sweep) \times (transmission symbol period).
5. Perform the measurement over a single sweep.
6. Use the peak marker function to determine the maximum power level in any 100 kHz band segment within the fundamental EBW.

Measurement Procedure –Unwanted Emission Level

1. Set RBW = 100 kHz.
2. Set VBW \geq 300 kHz.
3. Set span to encompass the spectrum to be examined
4. Detector = power average (RMS).
5. Manually set the sweep time to $\geq 10 \times$ (number of measurement points in sweep) \times (transmission symbol period).
6. Perform the measurement over a single sweep.
7. Use the peak marker function to determine the maximum power level in any 100 kHz band segment within the fundamental EBW.

4.6.4 DEVIATION FROM TEST STANDARD

No deviation

4.6.5 TEST SETUP

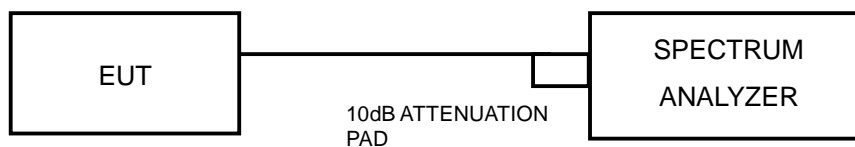

4.6.6 EUT OPERATING CONDITION

Same as Item 4.3.6

4.6.7 TEST RESULTS

The spectrum plots are attached on the following pages. D1 line indicates the highest level, and D2 line indicates the 30dB offset below D1. It shows compliance with the requirement.



A D T

802.11b:

Maximum REF

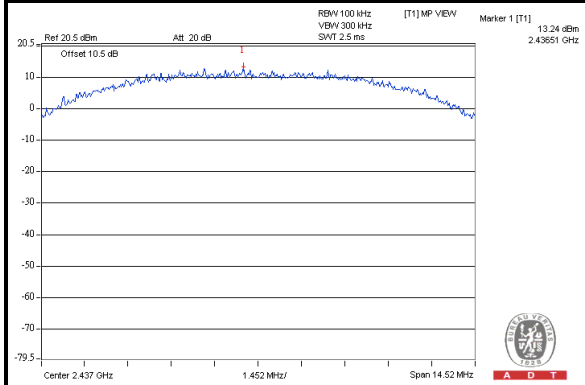

CH 1

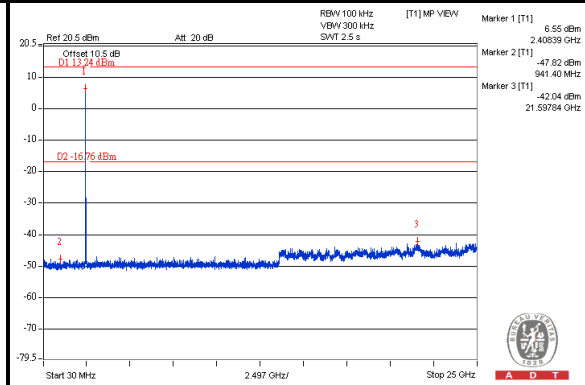

CH 6

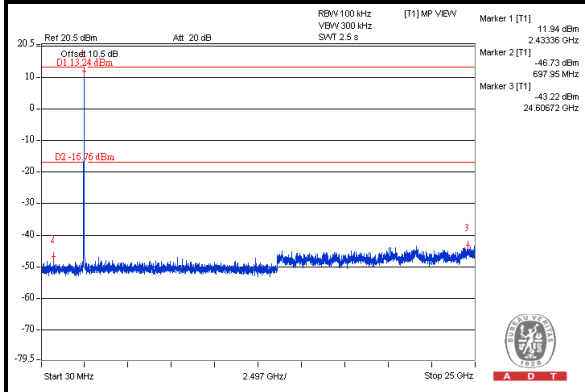

CH 11

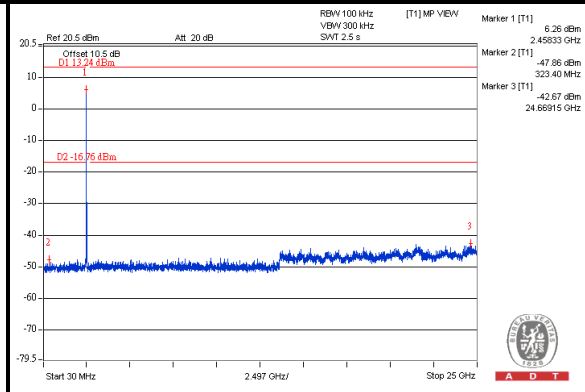



A D T

802.11g:

Maximum REF

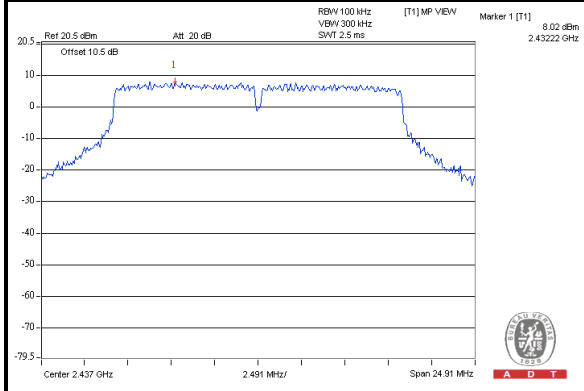

CH 1

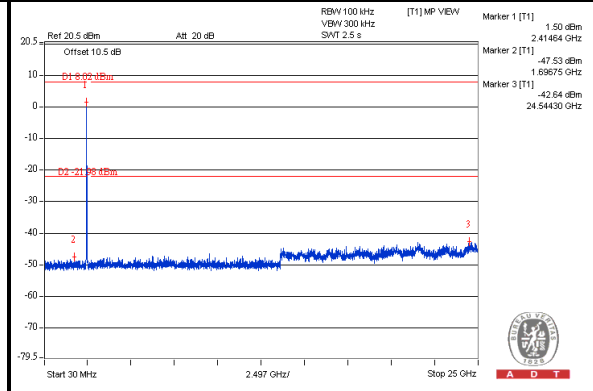

CH 6

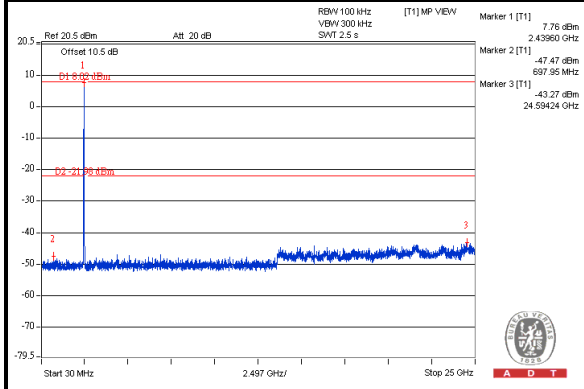

CH 11

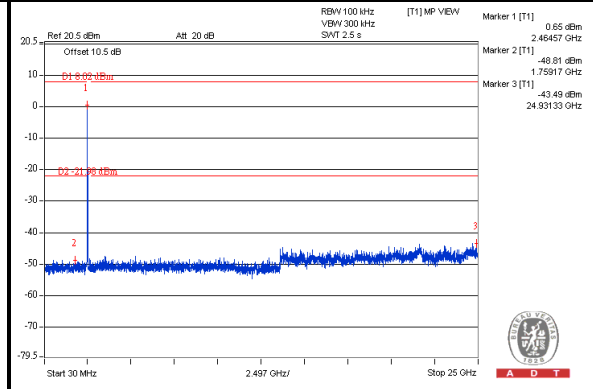



A D T

802.11n (HT20):

Chain(0)

Maximum REF

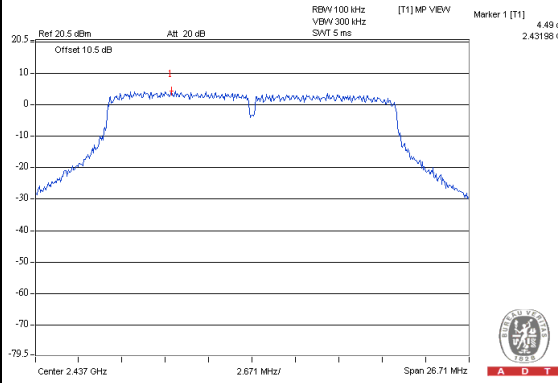

CH 1

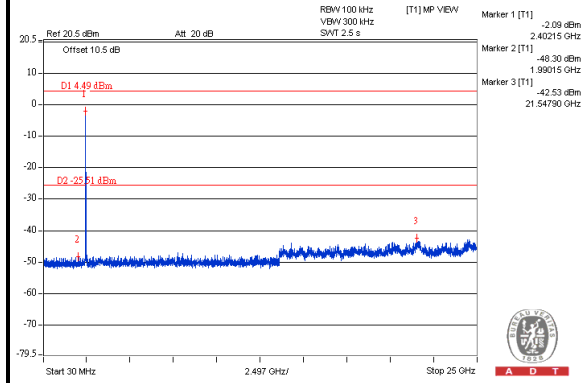

CH 6

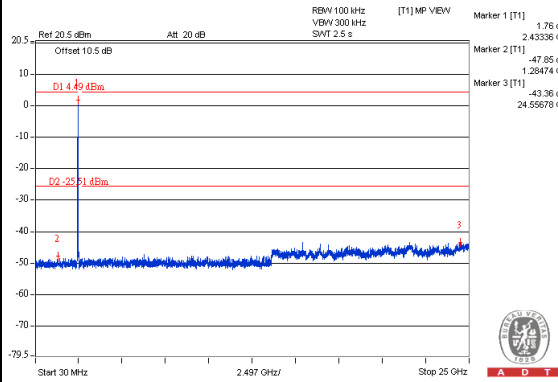

CH 11

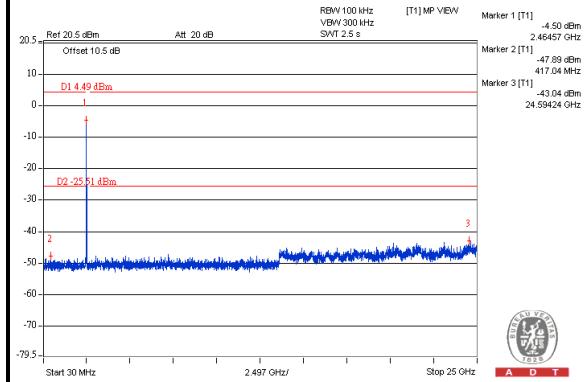



A D T

Chain(1)

Maximum REF

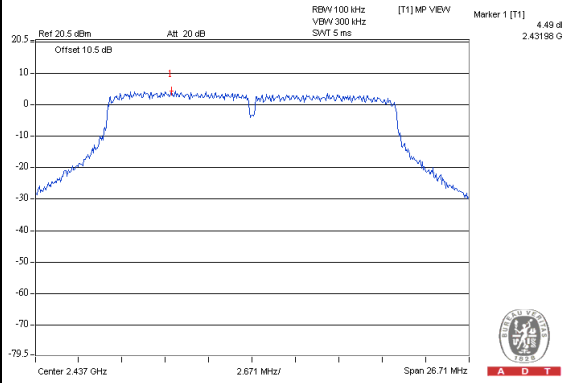

CH 1

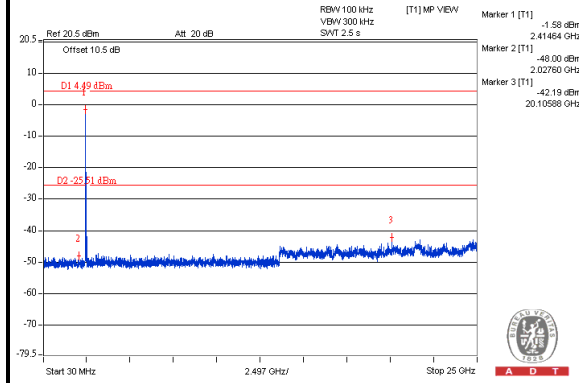

CH 6

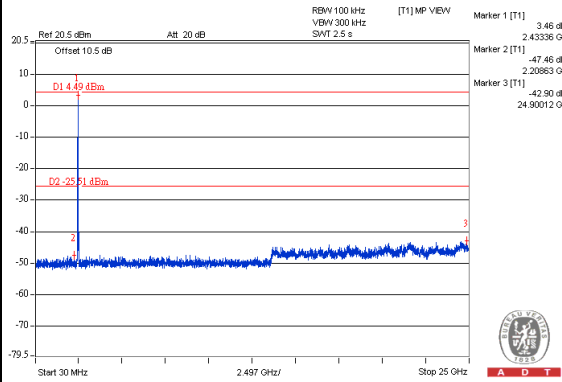

CH 11

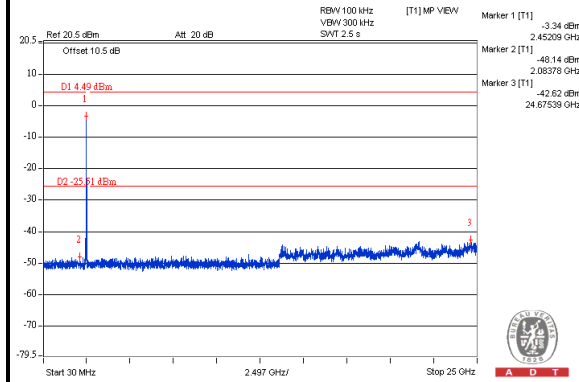



A D T

802.11n (HT40):

Chain(0)

Maximum REF

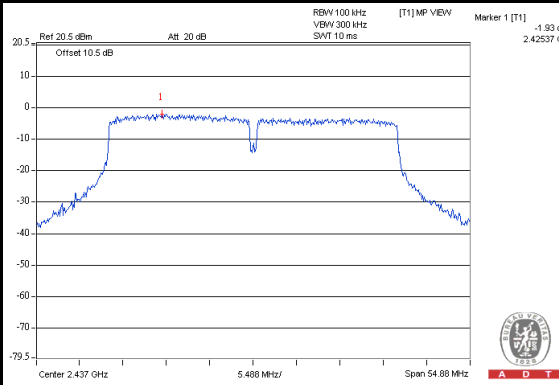

CH 3

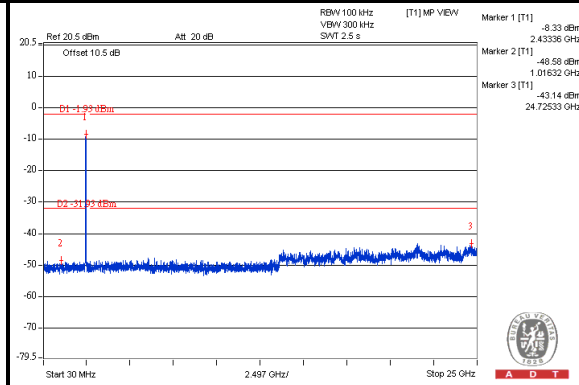

CH 6

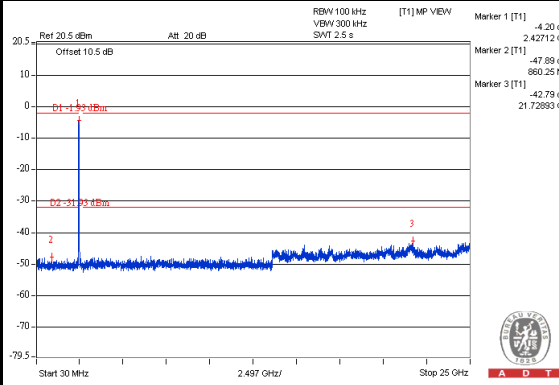

CH 9

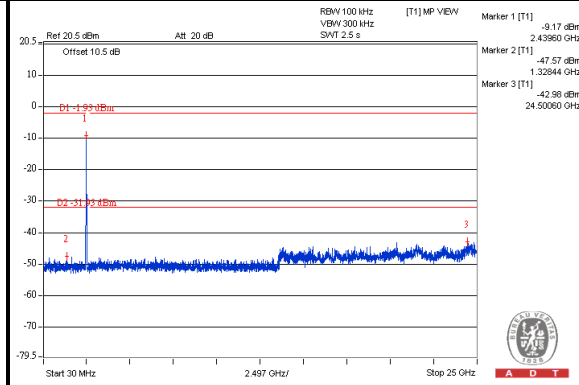



A D T

Chain(1)

Maximum REF

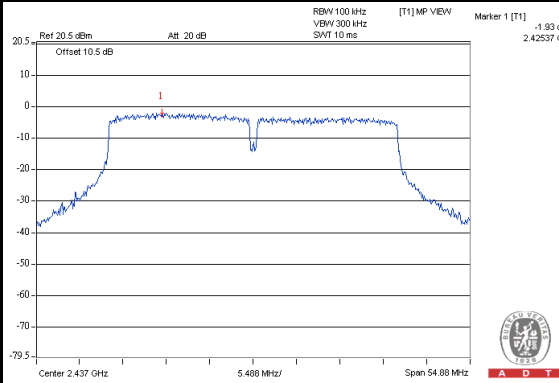

CH 3

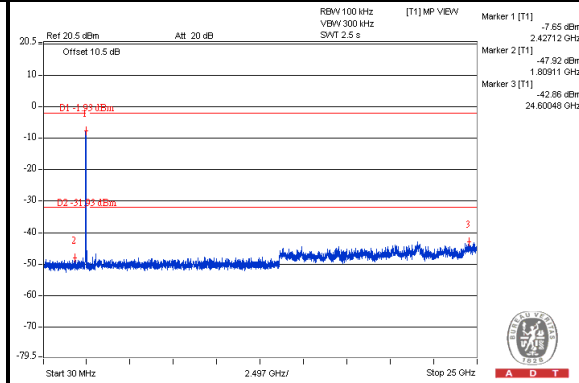

CH 6

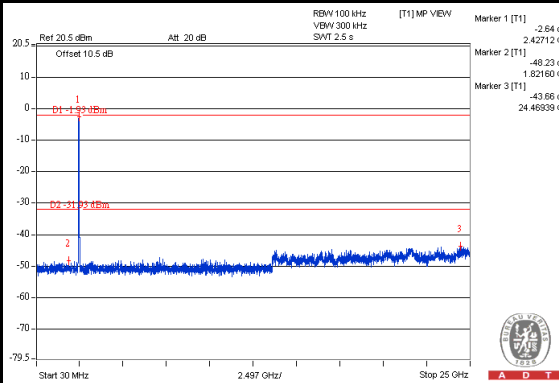

CH 9

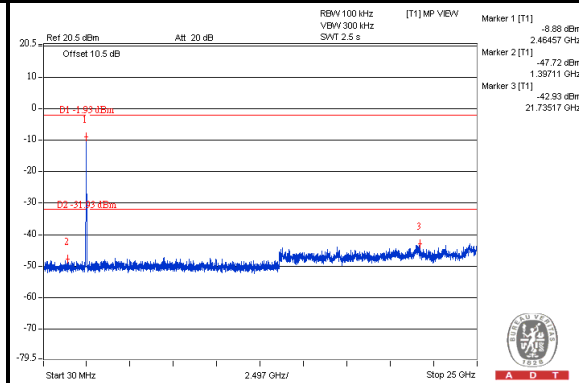



A D T

5. TEST TYPES AND RESULTS (FOR 5GHz, 5.725~5.850GHz Band)

5.1 CONDUCTED EMISSION MEASUREMENT

5.1.1 LIMITS OF CONDUCTED EMISSION MEASUREMENT

FREQUENCY OF EMISSION (MHz)	CONDUCTED LIMIT (dB μ V)	
	Quasi-peak	Average
0.15-0.5	66 to 56	56 to 46
0.5-5	56	46
5-30	60	50

- NOTE:**
1. The lower limit shall apply at the transition frequencies.
 2. The limit decreases in line with the logarithm of the frequency in the range of 0.15 to 0.50 MHz.

5.1.2 TEST INSTRUMENTS

DESCRIPTION & MANUFACTURER	MODEL NO.	SERIAL NO.	CALIBRATED DATE	CALIBRATED UNTIL
Test Receiver ROHDE & SCHWARZ	ESCS 30	100287	Feb. 29, 2012	Feb. 28, 2013
Line-Impedance Stabilization Network (for EUT) SCHWARZBECK	NSLK 8127	8127-523	Sep. 19, 2012	Sep. 20, 2013
Line-Impedance Stabilization Network (for Peripheral) ROHDE & SCHWARZ	ESH3-Z5	848773/004	Oct. 29, 2012	Oct. 28, 2013
RF Cable (JYEBAO)	5DFB	COACAB-002	Aug. 05, 2012	Aug. 04, 2013
50 ohms Terminator	50	3	Oct. 23, 2012	Oct. 22, 2013
Software ADT	BV ADT_Cond_V7.3.7 .3	NA	NA	NA

Note:

1. The calibration interval of the above test instruments is 12 months and the calibrations are traceable to NML/ROC and NIST/USA.
2. The test was performed in Shielded Room No. A.
- 3 The VCCI Con A Registration No. is C-817.
4. Tested Date: Jan. 03, 2013

5.1.3 TEST PROCEDURES

- a. The EUT was placed 0.4 meters from the conducting wall of the shielded room with EUT being connected to the power mains through a line impedance stabilization network (LISN). Other support units were connected to the power mains through another LISN.
- b. The two LISNs provide 50 ohm/ 50uH of coupling impedance for the measuring instrument.
- c. Both lines of the power mains connected to the EUT were checked for maximum conducted interference.
- d. The frequency range from 150kHz to 30MHz was searched. Emission levels under (Limit – 20dB) were not recorded.

NOTE:

1. The resolution bandwidth of test receiver is 9kHz for Quasi-peak detection (QP) & Average detection (AV).

5.1.4 DEVIATION FROM TEST STANDARD

No deviation

5.1.5 TEST SETUP

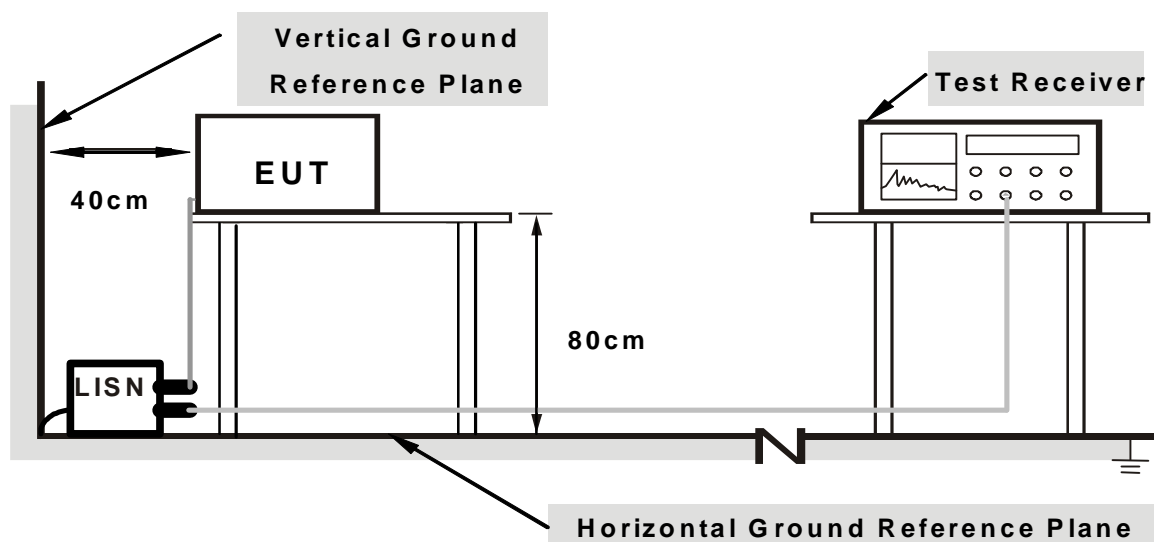

Note: 1. Support units were connected to second LISN.

For the actual test configuration, please refer to the related item – Photographs of the Test Configuration.

5.1.6 EUT OPERATING CONDITIONS

Same as the 4.1.6

5.1.7 TEST RESULTS

PHASE	Line (L)	DETECTOR FUNCTION	Quasi-Peak (QP) / Average (AV)
--------------	----------	--------------------------	--------------------------------

No	Freq. [MHz]	Corr. Factor (dB)	Reading Value		Emission Level		Limit		Margin	
			[dB (uV)]		[dB (uV)]		[dB (uV)]		(dB)	
			Q.P.	AV.	Q.P.	AV.	Q.P.	AV.	Q.P.	AV.
1	0.16172	0.10	40.82	40.41	40.92	40.51	65.38	55.38	-24.46	-14.87
2	0.27109	0.13	40.78	32.74	40.91	32.87	61.08	51.08	-20.18	-18.22
3	2.72684	0.26	43.63	33.76	43.89	34.02	56.00	46.00	-12.11	-11.98
4	3.34766	0.29	44.06	37.41	44.35	37.70	56.00	46.00	-11.65	-8.30
5	3.82031	0.31	36.00	27.14	36.31	27.45	56.00	46.00	-19.69	-18.55
6	12.82031	0.69	39.41	37.47	40.10	38.16	60.00	50.00	-19.90	-11.84

REMARKS:

1. Q.P. and AV. are abbreviations of quasi-peak and average individually.
2. The emission levels of other frequencies were very low against the limit.
3. Margin value = Emission level - Limit value
4. Correction factor = Insertion loss + Cable loss
5. Emission Level = Correction Factor + Reading Value.

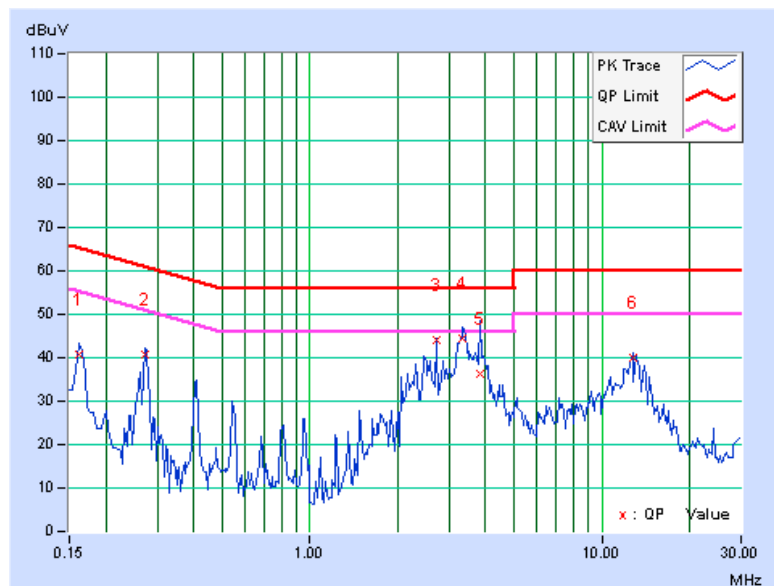



A D T

PHASE	Neutral (N)	DETECTOR FUNCTION	Quasi-Peak (QP) / Average (AV)
--------------	-------------	--------------------------	--------------------------------

No	Freq. [MHz]	Corr. Factor (dB)	Reading Value [dB (uV)]		Emission Level [dB (uV)]		Limit [dB (uV)]		Margin (dB)	
			Q.P.	AV.	Q.P.	AV.	Q.P.	AV.	Q.P.	AV.
	1	0.27109	0.16	38.40	37.36	38.56	37.52	61.08	51.08	-22.52
2	2.59375	0.29	41.44	34.09	41.73	34.38	56.00	46.00	-14.27	-11.62
3	2.73047	0.30	44.44	35.04	44.74	35.34	56.00	46.00	-11.26	-10.66
4	3.36328	0.32	42.75	36.54	43.07	36.86	56.00	46.00	-12.93	-9.14
5	3.96875	0.35	38.13	31.63	38.48	31.98	56.00	46.00	-17.52	-14.02
6	11.95313	0.59	35.16	28.58	35.75	29.17	60.00	50.00	-24.25	-20.83

REMARKS:

1. Q.P. and AV. are abbreviations of quasi-peak and average individually.
2. The emission levels of other frequencies were very low against the limit.
3. Margin value = Emission level - Limit value
4. Correction factor = Insertion loss + Cable loss
5. Emission Level = Correction Factor + Reading Value.

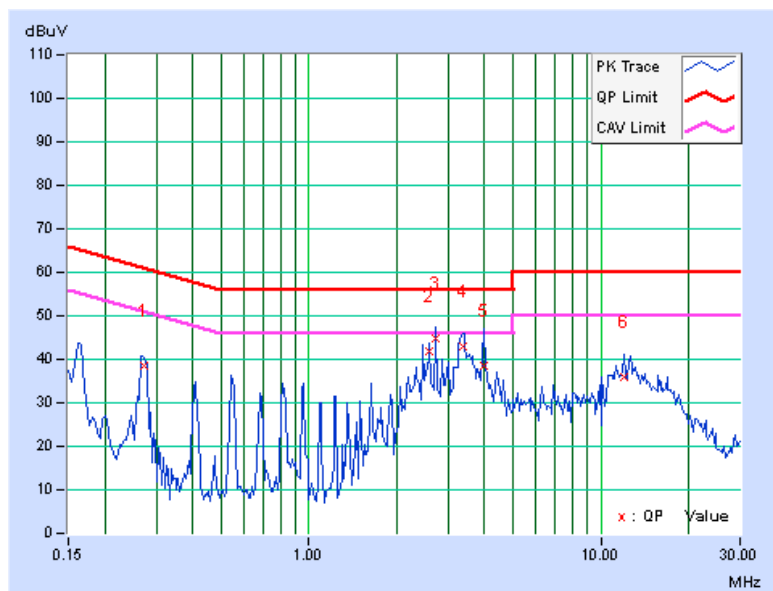

5.2 RADIATED AND BANDEDGE EMISSION MEASUREMENT

5.2.1 LIMITS OF RADIATED AND BANDEDGE EMISSION MEASUREMENT

Radiated emissions which fall in the restricted bands must comply with the radiated emission limits specified as below table. Other emissions shall be at least 30dB below the highest level of the desired power:

Frequencies (MHz)	Field strength (microvolts/meter)	Measurement distance (meters)
0.009-0.490	2400/F(kHz)	300
0.490-1.705	24000/F(kHz)	30
1.705-30.0	30	30
30-88	100	3
88-216	150	3
216-960	200	3
Above 960	500	3

NOTE:

1. The lower limit shall apply at the transition frequencies.
2. Emission level (dBuV/m) = 20 log Emission level (uV/m).
3. For frequencies above 1000MHz, the field strength limits are based on average detector, however, the peak field strength of any emission shall not exceed the maximum permitted average limits, specified above by more than 20dB under any condition of modulation.



A D T

5.2.2 TEST INSTRUMENTS

DESCRIPTION & MANUFACTURER	MODEL NO.	SERIAL NO.	CALIBRATED DATE	CALIBRATED UNTIL
Spectrum Analyzer Agilent	E4446A	MY48250254	July 09, 2012	July 08, 2013
Pre-Selector Agilent	N9039A	MY46520311	July 09, 2012	July 08, 2013
Signal Generator Agilent	N5181A	MY49060517	July 09, 2012	July 08, 2013
Pre-Amplifier Mini-Circuits	ZFL-1000VH2 B	AMP-ZFL-03	Nov. 14, 2012	Nov. 13, 2013
Pre-Amplifier Agilent	8449B	3008A02578	June 26, 2012	June 25, 2013
Pre-Amplifier SPACEK LABS	SLKka-48-6	9K16	Nov. 14, 2012	Nov. 13, 2013
Trilog Broadband Antenna SCHWARZBECK	VULB 9168	9168-360	Apr. 09, 2012	Apr. 08, 2013
Horn_Antenna AISi	AIH.8018	0000320091110	Nov. 19, 2012	Nov. 18, 2013
Horn_Antenna SCHWARZBECK	BBHA 9170	9170-424	Oct. 12, 2012	Oct. 11, 2013
RF Cable	NA	RF104-201 RF104-203 RF104-204	Dec. 25, 2012	Dec. 24, 2013
RF Cable	NA	CHGCAB_001	Oct. 06, 2012	Oct. 05, 2013
Software	ADT_Radiated _V8.7.05	NA	NA	NA
Antenna Tower & Turn Table CT	NA	NA	NA	NA

Note:

1. The calibration interval of the above test instruments is 12 months and the calibrations are traceable to NML/ROC and NIST/USA.
2. The horn antenna, preamplifier (model: 8449B) are used only for the measurement of emission frequency above 1GHz if tested.
- 3 The test was performed in 966 Chamber No. G.
4. The FCC Site Registration No. is 966073.
- 5 The VCCI Site Registration No. is G-137.
- 6 The CANADA Site Registration No. is IC 7450H-2.
- 7 Tested Date: Jan. 04, 2013

5.2.3 TEST PROCEDURES

- a. The EUT was placed on the top of a rotating table 0.8 meters above the ground at 3 meter chamber room for test. The table was rotated 360 degrees to determine the position of the highest radiation.
- b. The EUT was set 3 meters away from the interference-receiving antenna, which was mounted on the top of a variable-height antenna tower.
- c. The height of antenna is varied from one meter to four meters above the ground to determine the maximum value of the field strength. Both horizontal and vertical polarizations of the antenna are set to make the measurement.
- d. For each suspected emission, the EUT was arranged to its worst case and then the antenna was tuned to heights from 1 meter to 4 meters and the rotatable table was turned from 0 degrees to 360 degrees to find the maximum reading.
- e. The test-receiver system was set to quasi-peak detect function and specified bandwidth with maximum hold mode when the test frequency is below 1 GHz.
- f. The test-receiver system was set to peak and average detect function and specified bandwidth with maximum hold mode when the test frequency is above 1 GHz. If the peak reading value also meets average limit, measurement with the average detector is unnecessary.

NOTE:

1. The resolution bandwidth and video bandwidth of test receiver/spectrum analyzer is 120kHz for Quasi-peak detection (QP) at frequency below 1GHz.
2. The resolution bandwidth of test receiver/spectrum analyzer is 1 MHz and the video bandwidth is 3 MHz for Peak detection (PK) at frequency above 1GHz.
3. The resolution bandwidth of test receiver/spectrum analyzer is 1 MHz and the video bandwidth is 10 Hz for Average detection (AV) at frequency above 1GHz.
4. All modes of operation were investigated and the worst-case emissions are reported.

5.2.4 DEVIATION FROM TEST STANDARD

No deviation

5.2.5 TEST SETUP

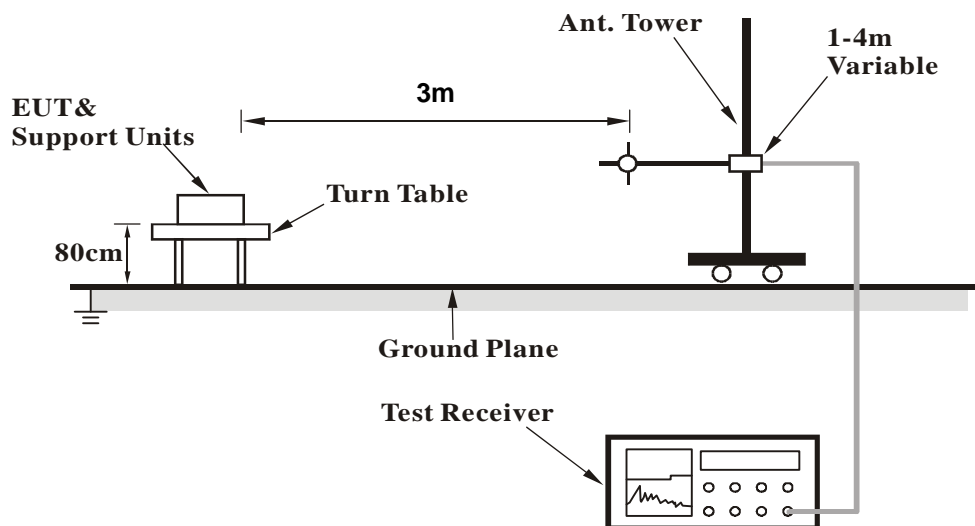

For the actual test configuration, please refer to the related item – Photographs of the Test Configuration.

5.2.6 EUT OPERATING CONDITIONS

Same as the 4.1.6

5.2.7 TEST RESULTS

BELOW 1GHz WORST-CASE DATA

802.11n (HT20)

CHANNEL	TX Channel 149	DETECTOR FUNCTION	Quasi-Peak (QP)
FREQUENCY RANGE	Below 1GHz		

ANTENNA POLARITY & TEST DISTANCE: HORIZONTAL AT 3 M

NO.	FREQ. (MHz)	EMISSION LEVEL (dBuV/m)	LIMIT (dBuV/m)	MARGIN (dB)	ANTENNA HEIGHT (m)	TABLE ANGLE (Degree)	RAW VALUE (dBuV)	CORRECTION FACTOR (dB/m)
1	72.00	35.4 QP	40.0	-4.6	2.00 H	94	23.35	12.04
2	124.90	37.1 QP	43.5	-6.4	1.50 H	123	24.19	12.90
3	199.40	35.2 QP	43.5	-8.3	1.00 H	216	24.02	11.21
4	250.00	37.1 QP	46.0	-9.0	1.00 H	305	23.70	13.35
5	750.00	34.7 QP	46.0	-11.3	1.00 H	335	9.77	24.91
6	799.90	34.0 QP	46.0	-12.0	1.00 H	333	8.08	25.92

ANTENNA POLARITY & TEST DISTANCE: VERTICAL AT 3 M

NO.	FREQ. (MHz)	EMISSION LEVEL (dBuV/m)	LIMIT (dBuV/m)	MARGIN (dB)	ANTENNA HEIGHT (m)	TABLE ANGLE (Degree)	RAW VALUE (dBuV)	CORRECTION FACTOR (dB/m)
1	84.00	33.8 QP	40.0	-6.3	2.00 V	0	24.49	9.26
2	124.91	34.2 QP	43.5	-9.3	2.00 V	197	21.28	12.90
3	185.20	35.9 QP	43.5	-7.6	1.00 V	20	23.41	12.49
4	223.60	35.6 QP	46.0	-10.4	1.00 V	351	23.43	12.19
5	250.00	35.3 QP	46.0	-10.8	2.00 V	360	21.90	13.35
6	500.00	36.7 QP	46.0	-9.3	2.00 V	358	16.35	20.39

REMARKS:

1. Emission level (dBuV/m) = Raw Value (dBuV) + Correction Factor (dB/m).
2. Correction Factor (dB/m) = Antenna Factor (dB/m) + Cable Factor (dB).
3. The other emission levels were very low against the limit.
4. Margin value = Emission level – Limit value.



ABOVE 1GHz DATA

802.11a

CHANNEL	TX Channel 149	DETECTOR FUNCTION	Peak (PK)
FREQUENCY RANGE	1GHz ~ 40GHz		Average (AV)

ANTENNA POLARITY & TEST DISTANCE: HORIZONTAL AT 3 M								
NO.	FREQ. (MHz)	EMISSION LEVEL (dBuV/m)	LIMIT (dBuV/m)	MARGIN (dB)	ANTENNA HEIGHT (m)	TABLE ANGLE (Degree)	RAW VALUE (dBuV)	CORRECTION FACTOR (dB/m)
1	5357.88	63.7 PK	74.0	-10.3	1.09 H	345	21.10	42.60
2	5357.88	52.2 AV	54.0	-1.8	1.09 H	345	9.60	42.60
3	*5745.00	117.8 PK			1.09 H	360	74.48	43.32
4	*5745.00	106.0 AV			1.09 H	360	62.68	43.32
5	11490.00	57.5 PK	74.0	-16.5	1.00 H	17	7.71	49.79
6	11490.00	45.5 AV	54.0	-8.5	1.00 H	17	-4.29	49.79

ANTENNA POLARITY & TEST DISTANCE: VERTICAL AT 3 M								
NO.	FREQ. (MHz)	EMISSION LEVEL (dBuV/m)	LIMIT (dBuV/m)	MARGIN (dB)	ANTENNA HEIGHT (m)	TABLE ANGLE (Degree)	RAW VALUE (dBuV)	CORRECTION FACTOR (dB/m)
1	5357.88	58.4 PK	74.0	-15.6	1.00 V	12	15.80	42.60
2	5357.88	48.5 AV	54.0	-5.5	1.00 V	12	5.90	42.60
3	*5745.00	105.4 PK			1.01 V	21	62.08	43.32
4	*5745.00	95.0 AV			1.01 V	21	51.68	43.32
5	11490.00	57.6 PK	74.0	-16.4	1.00 V	85	7.81	49.79
6	11490.00	45.0 AV	54.0	-9.0	1.00 V	85	-4.79	49.79

REMARKS:

1. Emission level (dBuV/m) = Raw Value (dBuV) + Correction Factor (dB/m).
2. Correction Factor (dB/m) = Antenna Factor (dB/m) + Cable Factor (dB).
3. The other emission levels were very low against the limit.
4. Margin value = Emission level – Limit value.
5. " * ": Fundamental frequency.
6. The limit value is defined as per 15.247.



A D T

CHANNEL	TX Channel 157	DETECTOR FUNCTION	Peak (PK)
FREQUENCY RANGE	1GHz ~ 40GHz		Average (AV)

ANTENNA POLARITY & TEST DISTANCE: HORIZONTAL AT 3 M

NO.	FREQ. (MHz)	EMISSION LEVEL (dBuV/m)	LIMIT (dBuV/m)	MARGIN (dB)	ANTENNA HEIGHT (m)	TABLE ANGLE (Degree)	RAW VALUE (dBuV)	CORRECTION FACTOR (dB/m)
1	5382.20	64.6 PK	74.0	-9.4	1.09 H	346	22.00	42.60
2	5382.20	53.3 AV	54.0	-0.7	1.09 H	346	10.70	42.60
3	*5785.00	118.2 PK			1.03 H	353	74.83	43.37
4	*5785.00	106.2 AV			1.03 H	353	62.83	43.37
5	11570.00	58.1 PK	74.0	-15.9	1.00 H	26	8.27	49.83
6	11570.00	45.5 AV	54.0	-8.5	1.00 H	26	-4.33	49.83

ANTENNA POLARITY & TEST DISTANCE: VERTICAL AT 3 M

NO.	FREQ. (MHz)	EMISSION LEVEL (dBuV/m)	LIMIT (dBuV/m)	MARGIN (dB)	ANTENNA HEIGHT (m)	TABLE ANGLE (Degree)	RAW VALUE (dBuV)	CORRECTION FACTOR (dB/m)
1	5382.20	58.1 PK	74.0	-15.9	1.04 V	3	15.50	42.60
2	5382.20	48.4 AV	54.0	-5.6	1.04 V	3	5.80	42.60
3	*5785.00	103.7 PK			1.01 V	33	60.33	43.37
4	*5785.00	93.8 AV			1.01 V	33	50.43	43.37
5	11570.00	57.4 PK	74.0	-16.6	1.00 V	79	7.57	49.83
6	11570.00	44.9 AV	54.0	-9.1	1.00 V	79	-4.93	49.83

REMARKS:

1. Emission level (dBuV/m) = Raw Value (dBuV) + Correction Factor (dB/m).
2. Correction Factor (dB/m) = Antenna Factor (dB/m) + Cable Factor (dB).
3. The other emission levels were very low against the limit.
4. Margin value = Emission level – Limit value.
5. " * ": Fundamental frequency.
6. The limit value is defined as per 15.247.



A D T

CHANNEL	TX Channel 165	DETECTOR FUNCTION	Peak (PK)
FREQUENCY RANGE	1GHz ~ 40GHz		Average (AV)

ANTENNA POLARITY & TEST DISTANCE: HORIZONTAL AT 3 M

NO.	FREQ. (MHz)	EMISSION LEVEL (dBuV/m)	LIMIT (dBuV/m)	MARGIN (dB)	ANTENNA HEIGHT (m)	TABLE ANGLE (Degree)	RAW VALUE (dBuV)	CORRECTION FACTOR (dB/m)
1	5381.10	64.4 PK	74.0	-9.6	1.09 H	346	21.80	42.60
2	5381.10	52.8 AV	54.0	-1.2	1.09 H	346	10.20	42.60
3	*5825.00	117.8 PK			1.06 H	360	74.33	43.47
4	*5825.00	105.7 AV			1.06 H	360	62.23	43.47
5	11650.00	57.9 PK	74.0	-16.1	1.00 H	23	7.79	50.11
6	11650.00	45.2 AV	54.0	-8.8	1.00 H	23	-4.91	50.11

ANTENNA POLARITY & TEST DISTANCE: VERTICAL AT 3 M

NO.	FREQ. (MHz)	EMISSION LEVEL (dBuV/m)	LIMIT (dBuV/m)	MARGIN (dB)	ANTENNA HEIGHT (m)	TABLE ANGLE (Degree)	RAW VALUE (dBuV)	CORRECTION FACTOR (dB/m)
1	5381.10	57.5 PK	74.0	-16.5	1.07 V	5	14.90	42.60
2	5381.10	47.8 AV	54.0	-6.2	1.07 V	5	5.20	42.60
3	*5825.00	102.8 PK			1.05 V	47	59.33	43.47
4	*5825.00	93.6 AV			1.05 V	47	50.13	43.47
5	11650.00	57.2 PK	74.0	-16.8	1.00 V	74	7.09	50.11
6	11650.00	44.9 AV	54.0	-9.1	1.00 V	74	-5.21	50.11

REMARKS:

1. Emission level (dBuV/m) = Raw Value (dBuV) + Correction Factor (dB/m).
2. Correction Factor (dB/m) = Antenna Factor (dB/m) + Cable Factor (dB).
3. The other emission levels were very low against the limit.
4. Margin value = Emission level – Limit value.
5. " * ": Fundamental frequency.
6. The limit value is defined as per 15.247.



A D T

802.11n (HT20)

CHANNEL	TX Channel 149	DETECTOR FUNCTION	Peak (PK)
FREQUENCY RANGE	1GHz ~ 40GHz		Average (AV)

ANTENNA POLARITY & TEST DISTANCE: HORIZONTAL AT 3 M

NO.	FREQ. (MHz)	EMISSION LEVEL (dBuV/m)	LIMIT (dBuV/m)	MARGIN (dB)	ANTENNA HEIGHT (m)	TABLE ANGLE (Degree)	RAW VALUE (dBuV)	CORRECTION FACTOR (dB/m)
1	5370.00	63.0 PK	74.0	-11.0	1.22 H	346	20.40	42.60
2	5370.00	51.5 AV	54.0	-2.5	1.22 H	346	8.90	42.60
3	*5745.00	116.7 PK			1.10 H	353	73.38	43.32
4	*5745.00	106.0 AV			1.10 H	353	62.68	43.32
5	11490.00	58.2 PK	74.0	-15.8	1.00 H	25	8.41	49.79
6	11490.00	45.4 AV	54.0	-8.6	1.00 H	25	-4.39	49.79

ANTENNA POLARITY & TEST DISTANCE: VERTICAL AT 3 M

NO.	FREQ. (MHz)	EMISSION LEVEL (dBuV/m)	LIMIT (dBuV/m)	MARGIN (dB)	ANTENNA HEIGHT (m)	TABLE ANGLE (Degree)	RAW VALUE (dBuV)	CORRECTION FACTOR (dB/m)
1	5370.00	62.8 PK	74.0	-11.2	1.21 V	300	20.20	42.60
2	5370.00	51.4 AV	54.0	-2.6	1.21 V	300	8.80	42.60
3	*5745.00	105.7 PK			1.00 V	35	62.38	43.32
4	*5745.00	95.2 AV			1.00 V	35	51.88	43.32
5	11490.00	58.1 PK	74.0	-15.9	1.00 V	78	8.31	49.79
6	11490.00	45.2 AV	54.0	-8.8	1.00 V	78	-4.59	49.79

REMARKS:

1. Emission level (dBuV/m) = Raw Value (dBuV) + Correction Factor (dB/m).
2. Correction Factor (dB/m) = Antenna Factor (dB/m) + Cable Factor (dB).
3. The other emission levels were very low against the limit.
4. Margin value = Emission level – Limit value.
5. " * ": Fundamental frequency.
6. The limit value is defined as per 15.247.



A D T

CHANNEL	TX Channel 157	DETECTOR FUNCTION	Peak (PK)
FREQUENCY RANGE	1GHz ~ 40GHz		Average (AV)

ANTENNA POLARITY & TEST DISTANCE: HORIZONTAL AT 3 M

NO.	FREQ. (MHz)	EMISSION LEVEL (dBuV/m)	LIMIT (dBuV/m)	MARGIN (dB)	ANTENNA HEIGHT (m)	TABLE ANGLE (Degree)	RAW VALUE (dBuV)	CORRECTION FACTOR (dB/m)
1	5383.37	63.0 PK	74.0	-11.0	1.22 H	346	20.39	42.61
2	5383.37	51.8 AV	54.0	-2.2	1.22 H	346	9.19	42.61
3	*5785.00	116.1 PK			1.00 H	360	72.73	43.37
4	*5785.00	105.6 AV			1.00 H	360	62.23	43.37
5	11570.00	57.1 PK	74.0	-16.9	1.00 H	20	7.27	49.83
6	11570.00	45.3 AV	54.0	-8.7	1.00 H	20	-4.53	49.83

ANTENNA POLARITY & TEST DISTANCE: VERTICAL AT 3 M

NO.	FREQ. (MHz)	EMISSION LEVEL (dBuV/m)	LIMIT (dBuV/m)	MARGIN (dB)	ANTENNA HEIGHT (m)	TABLE ANGLE (Degree)	RAW VALUE (dBuV)	CORRECTION FACTOR (dB/m)
1	5383.37	62.9 PK	74.0	-11.1	1.21 V	291	20.29	42.61
2	5383.37	51.5 AV	54.0	-2.5	1.21 V	291	8.89	42.61
3	*5785.00	105.0 PK			1.05 V	27	61.63	43.37
4	*5785.00	94.7 AV			1.05 V	27	51.33	43.37
5	11570.00	57.2 PK	74.0	-16.8	1.00 V	71	7.37	49.83
6	11570.00	44.9 AV	54.0	-9.1	1.00 V	71	-4.93	49.83

REMARKS:

1. Emission level (dBuV/m) = Raw Value (dBuV) + Correction Factor (dB/m).
2. Correction Factor (dB/m) = Antenna Factor (dB/m) + Cable Factor (dB).
3. The other emission levels were very low against the limit.
4. Margin value = Emission level – Limit value.
5. " * ": Fundamental frequency.
6. The limit value is defined as per 15.247.



A D T

CHANNEL	TX Channel 165	DETECTOR FUNCTION	Peak (PK)
FREQUENCY RANGE	1GHz ~ 40GHz		Average (AV)

ANTENNA POLARITY & TEST DISTANCE: HORIZONTAL AT 3 M

NO.	FREQ. (MHz)	EMISSION LEVEL (dBuV/m)	LIMIT (dBuV/m)	MARGIN (dB)	ANTENNA HEIGHT (m)	TABLE ANGLE (Degree)	RAW VALUE (dBuV)	CORRECTION FACTOR (dB/m)
1	5381.72	63.5 PK	74.0	-10.5	1.22 H	346	20.90	42.60
2	5381.72	51.6 AV	54.0	-2.4	1.22 H	346	9.00	42.60
3	*5825.00	115.2 PK			1.02 H	360	71.73	43.47
4	*5825.00	105.0 AV			1.02 H	360	61.53	43.47
5	11650.00	56.2 PK	74.0	-17.8	1.00 H	8	6.09	50.11
6	11650.00	44.4 AV	54.0	-9.6	1.00 H	8	-5.71	50.11

ANTENNA POLARITY & TEST DISTANCE: VERTICAL AT 3 M

NO.	FREQ. (MHz)	EMISSION LEVEL (dBuV/m)	LIMIT (dBuV/m)	MARGIN (dB)	ANTENNA HEIGHT (m)	TABLE ANGLE (Degree)	RAW VALUE (dBuV)	CORRECTION FACTOR (dB/m)
1	5381.72	63.1 PK	74.0	-10.9	1.16 V	288	20.50	42.60
2	5381.72	51.4 AV	54.0	-2.6	1.16 V	288	8.80	42.60
3	*5825.00	104.8 PK			1.02 V	28	61.33	43.47
4	*5825.00	94.9 AV			1.02 V	28	51.43	43.47
5	11650.00	57.3 PK	74.0	-16.7	1.00 V	56	7.19	50.11
6	11650.00	45.0 AV	54.0	-9.0	1.00 V	56	-5.11	50.11

REMARKS:

1. Emission level (dBuV/m) = Raw Value (dBuV) + Correction Factor (dB/m).
2. Correction Factor (dB/m) = Antenna Factor (dB/m) + Cable Factor (dB).
3. The other emission levels were very low against the limit.
4. Margin value = Emission level – Limit value.
5. " * ": Fundamental frequency.
6. The limit value is defined as per 15.247.



A D T

802.11n (HT40)

CHANNEL	TX Channel 151	DETECTOR FUNCTION	Peak (PK)
FREQUENCY RANGE	1GHz ~ 40GHz		Average (AV)

ANTENNA POLARITY & TEST DISTANCE: HORIZONTAL AT 3 M								
NO.	FREQ. (MHz)	EMISSION LEVEL (dBuV/m)	LIMIT (dBuV/m)	MARGIN (dB)	ANTENNA HEIGHT (m)	TABLE ANGLE (Degree)	RAW VALUE (dBuV)	CORRECTION FACTOR (dB/m)
1	5372.37	62.5 PK	74.0	-11.5	1.20 H	347	19.90	42.60
2	5372.37	51.6 AV	54.0	-2.4	1.20 H	347	9.00	42.60
3	*5755.00	113.5 PK			1.11 H	353	70.16	43.34
4	*5755.00	103.0 AV			1.11 H	353	59.66	43.34
5	11510.00	56.5 PK	74.0	-17.5	1.00 H	10	6.72	49.78
6	11510.00	44.9 AV	54.0	-9.1	1.00 H	10	-4.88	49.78
ANTENNA POLARITY & TEST DISTANCE: VERTICAL AT 3 M								
NO.	FREQ. (MHz)	EMISSION LEVEL (dBuV/m)	LIMIT (dBuV/m)	MARGIN (dB)	ANTENNA HEIGHT (m)	TABLE ANGLE (Degree)	RAW VALUE (dBuV)	CORRECTION FACTOR (dB/m)
1	5372.37	62.4 PK	74.0	-11.6	1.15 V	288	19.80	42.60
2	5372.37	50.8 AV	54.0	-3.2	1.15 V	288	8.20	42.60
3	*5755.00	103.1 PK			1.04 V	12	59.76	43.34
4	*5755.00	92.1 AV			1.04 V	12	48.76	43.34
5	11510.00	57.5 PK	74.0	-16.5	1.00 V	54	7.72	49.78
6	11510.00	45.3 AV	54.0	-8.7	1.00 V	54	-4.48	49.78

REMARKS:

1. Emission level (dBuV/m) = Raw Value (dBuV) + Correction Factor (dB/m).
2. Correction Factor (dB/m) = Antenna Factor (dB/m) + Cable Factor (dB).
3. The other emission levels were very low against the limit.
4. Margin value = Emission level – Limit value.
5. " * ": Fundamental frequency.
6. The limit value is defined as per 15.247.



A D T

CHANNEL	TX Channel 159	DETECTOR FUNCTION	Peak (PK)
FREQUENCY RANGE	1GHz ~ 40GHz		Average (AV)

ANTENNA POLARITY & TEST DISTANCE: HORIZONTAL AT 3 M

NO.	FREQ. (MHz)	EMISSION LEVEL (dBuV/m)	LIMIT (dBuV/m)	MARGIN (dB)	ANTENNA HEIGHT (m)	TABLE ANGLE (Degree)	RAW VALUE (dBuV)	CORRECTION FACTOR (dB/m)
1	5384.60	65.6 PK	74.0	-8.4	1.20 H	347	22.99	42.61
2	5384.60	53.0 AV	54.0	-1.0	1.20 H	347	10.39	42.61
3	*5795.00	113.2 PK			1.07 H	329	69.82	43.38
4	*5795.00	102.9 AV			1.07 H	329	59.52	43.38
5	11590.00	56.6 PK	74.0	-17.4	1.00 H	3	6.76	49.84
6	11590.00	45.1 AV	54.0	-8.9	1.00 H	3	-4.74	49.84

ANTENNA POLARITY & TEST DISTANCE: VERTICAL AT 3 M

NO.	FREQ. (MHz)	EMISSION LEVEL (dBuV/m)	LIMIT (dBuV/m)	MARGIN (dB)	ANTENNA HEIGHT (m)	TABLE ANGLE (Degree)	RAW VALUE (dBuV)	CORRECTION FACTOR (dB/m)
1	5384.60	62.5 PK	74.0	-11.5	1.13 V	281	19.89	42.61
2	5384.60	51.0 AV	54.0	-3.0	1.13 V	281	8.39	42.61
3	*5795.00	103.4 PK			1.02 V	10	60.02	43.38
4	*5795.00	92.3 AV			1.02 V	10	48.92	43.38
5	11590.00	57.2 PK	74.0	-16.8	1.00 V	28	7.36	49.84
6	11590.00	44.8 AV	54.0	-9.2	1.00 V	28	-5.04	49.84

REMARKS:

1. Emission level (dBuV/m) = Raw Value (dBuV) + Correction Factor (dB/m).
2. Correction Factor (dB/m) = Antenna Factor (dB/m) + Cable Factor (dB).
3. The other emission levels were very low against the limit.
4. Margin value = Emission level – Limit value.
5. " * ": Fundamental frequency.
6. The limit value is defined as per 15.247.

5.3 6dB BANDWIDTH MEASUREMENT

5.3.1 LIMITS OF 6dB BANDWIDTH MEASUREMENT

The minimum of 6dB Bandwidth Measurement is 0.5 MHz.

5.3.2 TEST INSTRUMENTS

DESCRIPTION & MANUFACTURER	MODEL NO.	SERIAL NO.	CALIBRATED DATE	CALIBRATED UNTIL
R&S SPECTRUM ANALYZER	FSP40	100037	Nov. 01, 2012	Oct. 31, 2013

Note:

1. The calibration interval of the above test instruments is 12 months and the calibrations are traceable to NML/ROC and NIST/USA.
2. Tested date : Jan. 11, 2013

5.3.3 TEST PROCEDURE

1. Set resolution bandwidth (RBW) = approximately 1% of the emission bandwidth
2. Set the video bandwidth (VBW) $\geq 3 \times$ RBW, Detector = Peak.
3. Trace mode = max hold.
4. Sweep = auto couple.
5. Measure the maximum width of the emission that is constrained by the frequencies associated with the two amplitude points (upper and lower) that are attenuated by 6 dB relative to the maximum level measured in the fundamental emission

5.3.4 DEVIATION FROM TEST STANDARD

No deviation

5.3.5 TEST SETUP

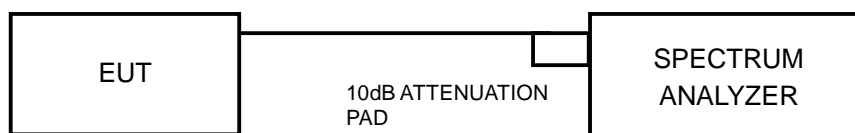

5.3.6 EUT OPERATING CONDITIONS

The software provided by client to enable the EUT under transmission condition continuously at lowest, middle and highest channel frequencies individually.



A D T

5.3.7 TEST RESULTS

802.11a

CHANNEL	FREQUENCY (MHz)	6dB BANDWIDTH (MHz)	MINIMUM LIMIT (MHz)	PASS / FAIL
149	5745	16.40	0.5	PASS
157	5785	16.41	0.5	PASS
165	5825	16.42	0.5	PASS

802.11n (HT20)

CHANNEL	CHANNEL FREQUENCY (MHz)	6dB BANDWIDTH (MHz)		MINIMUM LIMIT (MHz)	PASS / FAIL
		CHAIN 0	CHAIN 1		
149	5745	17.70	17.70	0.5	PASS
157	5785	17.66	17.69	0.5	PASS
165	5825	17.65	17.65	0.5	PASS

802.11n (HT40)

CHANNEL	CHANNEL FREQUENCY (MHz)	6dB BANDWIDTH (MHz)		MINIMUM LIMIT (MHz)	PASS / FAIL
		CHAIN 0	CHAIN 1		
151	5755	36.47	36.53	0.5	PASS
159	5795	36.40	36.51	0.5	PASS

5.4 CONDUCTED OUTPUT POWER MEASUREMENT

5.4.1 LIMITS OF CONDUCTED OUTPUT POWER MEASUREMENT

For systems using digital modulation in the 5725 –5850 MHz band: 1 Watt (30dBm)

Per KDB 662911 D01 Multiple Transmitter Output v01r02 Method of conducted output power measurement on IEEE 802.11 devices,

- Array Gain = 0 dB (i.e., no array gain) for NANT \leq 4;
- Array Gain = 0 dB (i.e., no array gain) for channel widths \geq 40 MHz for any NANT;
- Array Gain = 5 log(NANT/NSS) dB or 3 dB, whichever is less for 20-MHz channel widths with NANT \geq 5.

For power measurements on all other devices: Array Gain = 10 log(NANT/NSS) dB.

5.4.2 INSTRUMENTS

DESCRIPTION & MANUFACTURER	MODEL NO.	SERIAL NO.	CALIBRATED DATE	CALIBRATED UNTIL
Power Meter	ML2495A	0824006	May 10, 2012	May 09, 2013
Power Sensor	MA2411B	0738172	May 10, 2012	May 09, 2013

- Note:**
3. The calibration interval of the above test instruments is 12 months and the calibrations are traceable to NML/ROC and NIST/USA.
 4. Tested date : Jan. 11, 2013

5.4.3 TEST PROCEDURES

A average power sensor was used on the output port of the EUT. A power meter was used to read the response of the average power sensor. Record the average power level.

5.4.4 DEVIATION FROM TEST STANDARD

No deviation.

5.4.5 TEST SETUP

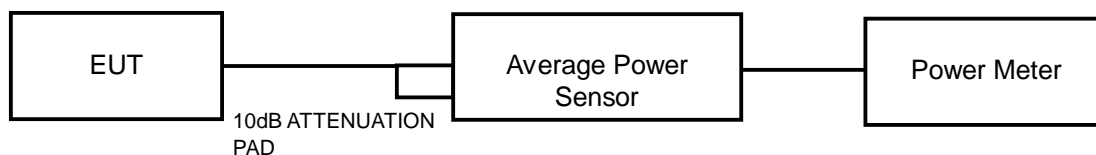

5.4.6 EUT OPERATING CONDITIONS

Same as Item 5.3.6



A D T

5.4.7 TEST RESULTS

802.11a

CHANNEL	FREQUENCY (MHz)	AVERAGE POWER (mW)	AVERAGE POWER (dBm)	LIMIT (dBm)	PASS/FAIL
149	5745	83.176	19.20	25.48	PASS
157	5785	77.625	18.90	25.48	PASS
165	5825	56.234	17.50	25.48	PASS

The directional gain is 10.52dBi, therefore the limit needs to reduce.

802.11n (HT20)

CHAN.	CHAN. FREQ. (MHz)	AVERAGE POWER (dBm)		TOTAL POWER (mW)	TOTAL POWER (dBm)	LIMIT (dBm)	PASS / FAIL
		CHAIN 0	CHAIN 1				
149	5745	18.10	17.90	126.225	21.01	25.48	PASS
157	5785	17.70	17.80	119.140	20.76	25.48	PASS
165	5825	16.50	17.00	94.787	19.77	25.48	PASS

The directional gain is 10.52dBi, therefore the limit needs to reduce.

802.11n (HT40)

CHAN.	CHAN. FREQ. (MHz)	AVERAGE POWER (dBm)		TOTAL POWER (mW)	TOTAL POWER (dBm)	LIMIT (dBm)	PASS / FAIL
		CHAIN 0	CHAIN 1				
151	5755	18.20	17.80	126.325	21.01	25.48	PASS
159	5795	17.50	17.90	117.894	20.71	25.48	PASS

The directional gain is 10.52dBi, therefore the limit needs to reduce.

5.5 POWER SPECTRAL DENSITY MEASUREMENT

5.5.1 LIMITS OF POWER SPECTRAL DENSITY MEASUREMENT

The Maximum of Power Spectral Density Measurement is 8dBm.

5.5.2 TEST INSTRUMENTS

DESCRIPTION & MANUFACTURER	MODEL NO.	SERIAL NO.	CALIBRATED DATE	CALIBRATED UNTIL
R&S Spectrum Analyzer	FSP40	100037	Nov. 01, 2012	Oct. 31, 2013

Note:

1. The calibration interval of the above test instruments is 12 months and the calibrations are traceable to NML/ROC and NIST/USA.
2. Tested date : Jan. 11, 2013

5.5.3 TEST PROCEDURE

1. Set the RBW = 3 kHz, VBW =10 kHz, Detector = power averaging (RMS) .
2. Ensure that the number of measurement points in the sweep $\geq 2 \times \text{span/RBW}$
3. Sweep time = auto couple,
4. Employ trace averaging (RMS) mode over a minimum of 100 traces.
5. Use the peak marker function to determine the maximum amplitude level.

5.5.4 DEVIATION FROM TEST STANDARD

No deviation

5.5.5 TEST SETUP

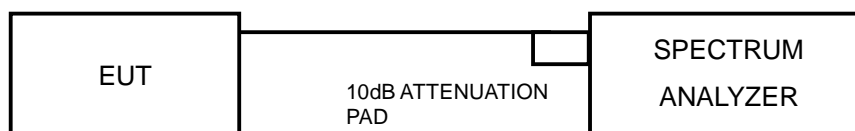

5.5.6 EUT OPERATING CONDITION

Same as Item 4.3.6



A D T

5.5.7 TEST RESULTS

802.11a

Channel	FREQUENCY (MHz)	PSD (dBm/3kHz)	Limit (dBm/3kHz)	PASS /FAIL
149	5745	-6.44	3.48	PASS
157	5785	-7.84	3.48	PASS
165	5825	-9.28	3.48	PASS

The directional gain is 10.52dBi, therefore the limit needs to reduce.

802.11n (HT20)

TX chain	Channel	FREQ. (MHz)	PSD (dBm/3kHz)	10 log (N=2) dB	Total PSD (dBm/3kHz)	Limit (dBm/3kHz)	PASS /FAIL
0	149	5745	-8.26	3.01	-5.25	3.48	PASS
	157	5785	-8.42	3.01	-5.41	3.48	PASS
	165	5825	-10.49	3.01	-7.48	3.48	PASS
1	149	5745	-8.70	3.01	-5.69	3.48	PASS
	157	5785	-8.29	3.01	-5.28	3.48	PASS
	165	5825	-8.66	3.01	-5.65	3.48	PASS

The directional gain is 10.52dBi, therefore the limit needs to reduce.

802.11n (HT40)

TX chain	Channel	FREQ. (MHz)	PSD (dBm/3kHz)	10 log (N=2) dB	Total PSD (dBm/3kHz)	Limit (dBm/3kHz)	PASS /FAIL
0	151	5755	-10.15	3.01	-7.14	3.48	PASS
	159	5795	-10.96	3.01	-7.95	3.48	PASS
1	151	5755	-10.34	3.01	-7.33	3.48	PASS
	159	5795	-10.87	3.01	-7.86	3.48	PASS

The directional gain is 10.52dBi, therefore the limit needs to reduce.

5.6 CONDUCTED OUT-BAND EMISSION MEASUREMENT

5.6.1 LIMITS OF CONDUCTED OUT-BAND EMISSION MEASUREMENT

Below 30dB of the highest emission level of operating band (in 100kHz Resolution Bandwidth).

5.6.2 TEST INSTRUMENTS

DESCRIPTION & MANUFACTURER	MODEL NO.	SERIAL NO.	CALIBRATED DATE	CALIBRATED UNTIL
R&S Spectrum Analyzer	FSP40	100037	Nov. 01, 2012	Oct. 31, 2013

Note:

1. The calibration interval of the above test instruments is 12 months and the calibrations are traceable to NML/ROC and NIST/USA.
2. Tested date : Jan. 11, 2013

5.6.3 TEST PROCEDURE

Measurement Procedure - Reference Level

1. Set the RBW = 100 kHz.
2. Set the VBW \geq 300 kHz.
3. Detector = peak.
4. Sweep time = auto couple.
5. Trace mode = max hold.
6. Allow trace to fully stabilize.
7. Use the peak marker function to determine the maximum power level in any 100 kHz band segment within the fundamental EBW.

Measurement Procedure –Unwanted Emission Level

1. Set RBW = 100 kHz.
2. Set VBW \geq 300 kHz.
3. Set span to encompass the spectrum to be examined
4. Detector = peak.
5. Trace Mode = max hold.
6. Sweep = auto couple.

5.6.4 DEVIATION FROM TEST STANDARD

No deviation

5.6.5 TEST SETUP

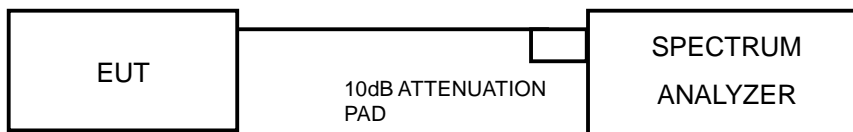

5.6.6 EUT OPERATING CONDITION

Same as Item 4.3.6

5.6.7 TEST RESULTS

The spectrum plots are attached on the following pages. D1 line indicates the highest level, and D2 line indicates the 30dB offset below D1. It shows compliance with the requirement.



A D T

802.11a

Maximum REF

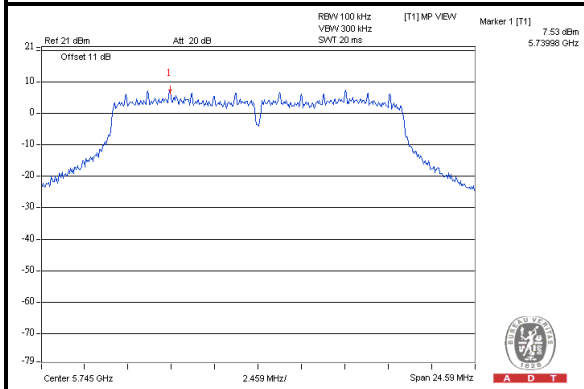

CH 149

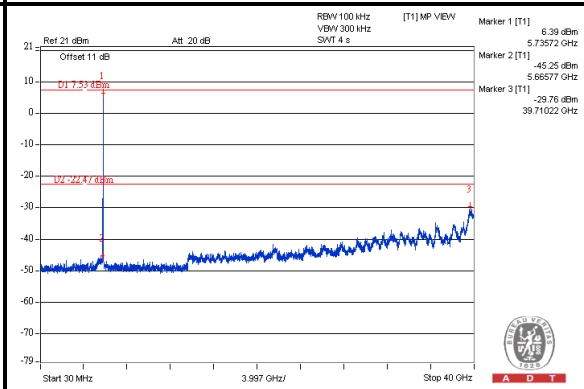

CH 157

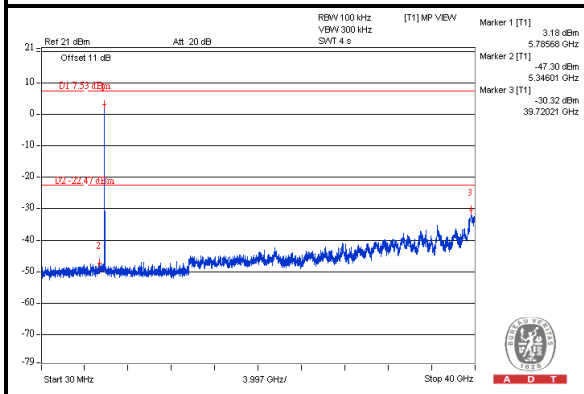

CH 165

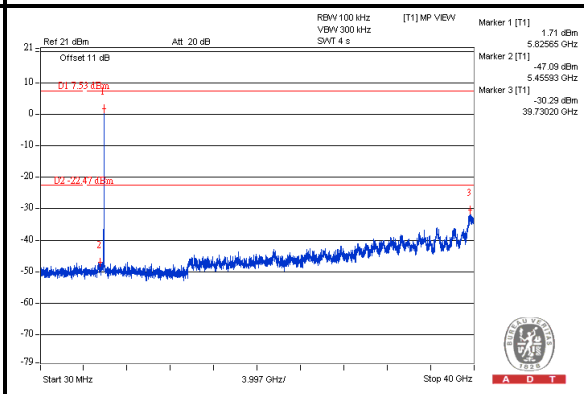



A D T

802.11n (HT20)

Chain(0)

Maximum REF

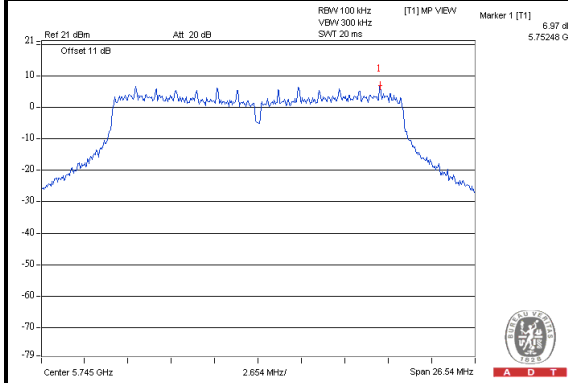

CH 149

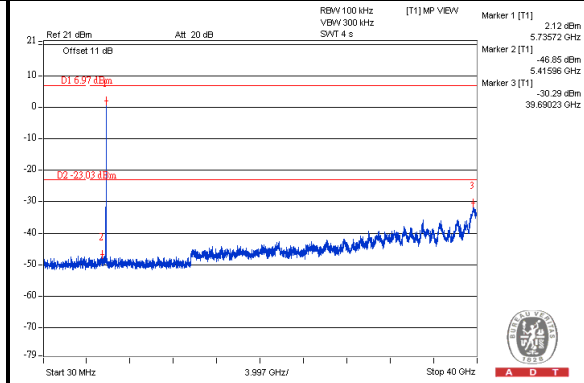

CH 157

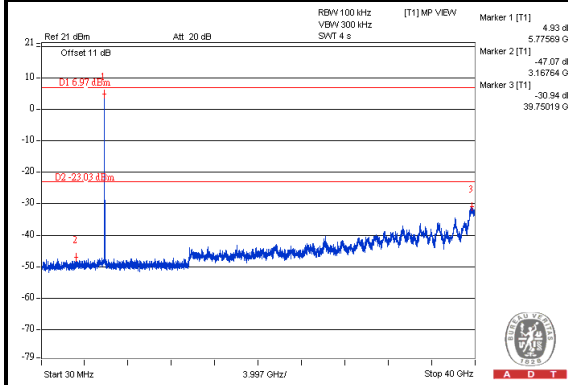

CH 165

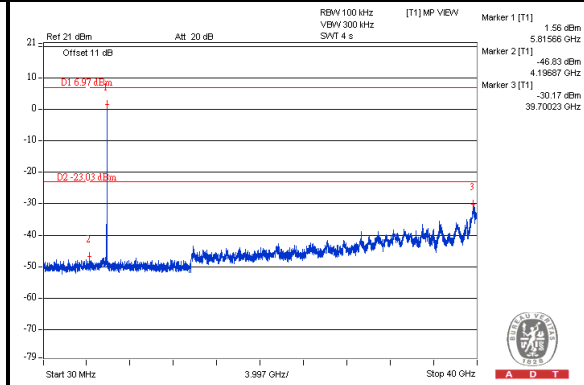



A D T

Chain(1)

Maximum REF

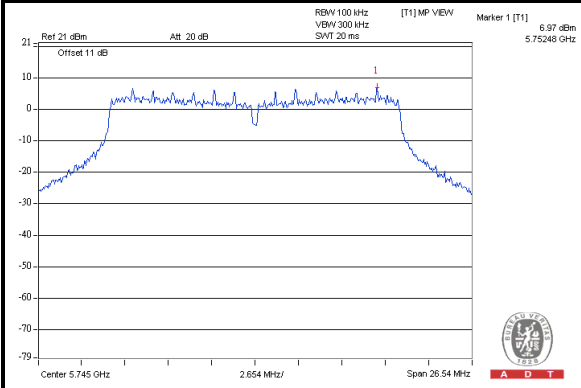

CH 149

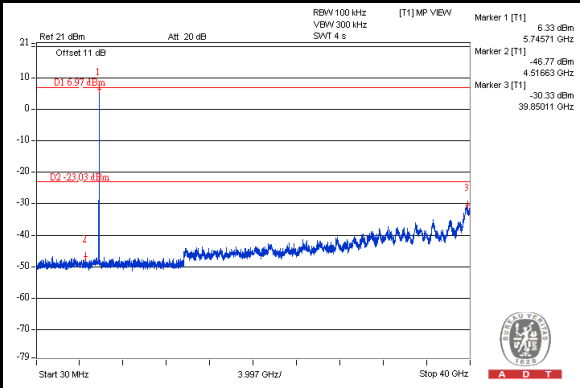

CH 157

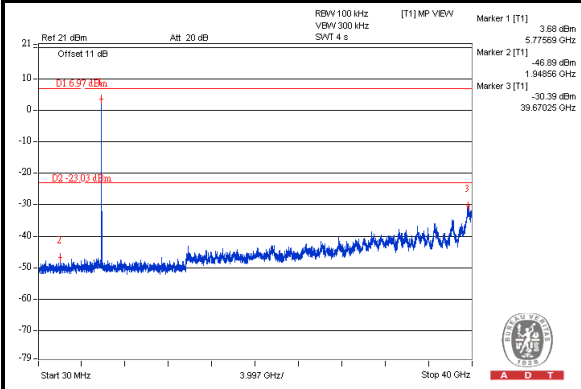

CH 165

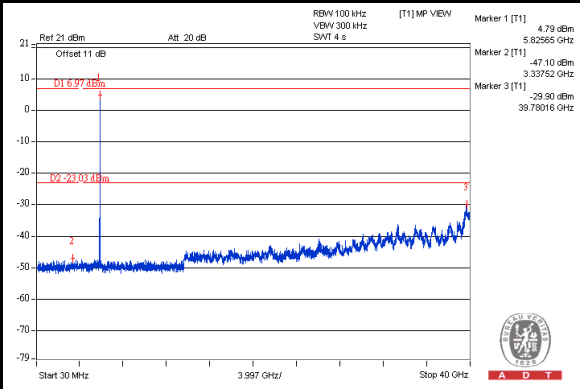



A D T

802.11n (HT40)

Chain(0)

Maximum REF

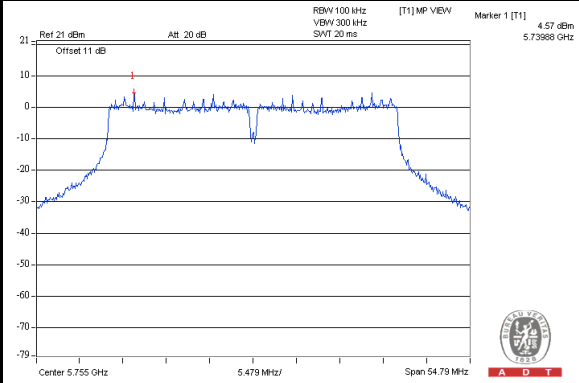

CH 151

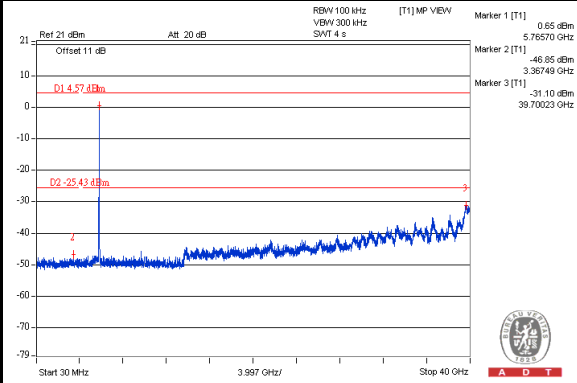

CH 159

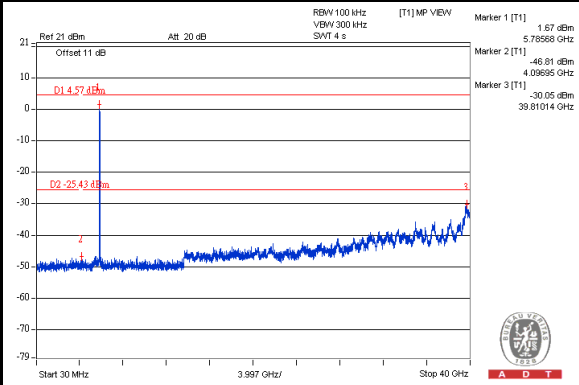



A D T

Chain(1)

Maximum REF

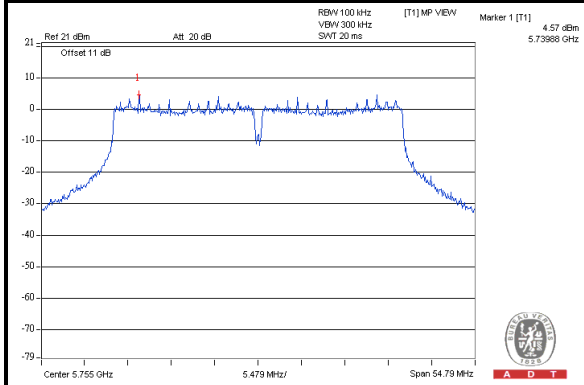

CH 151

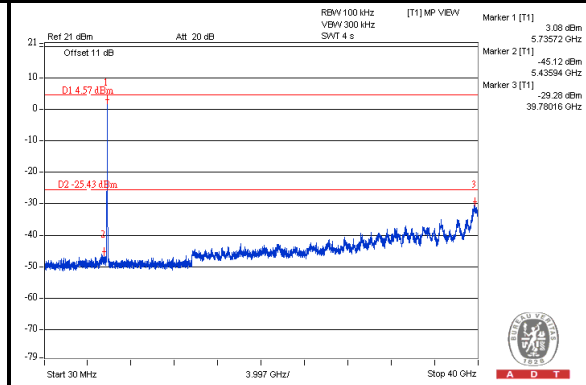

CH 159

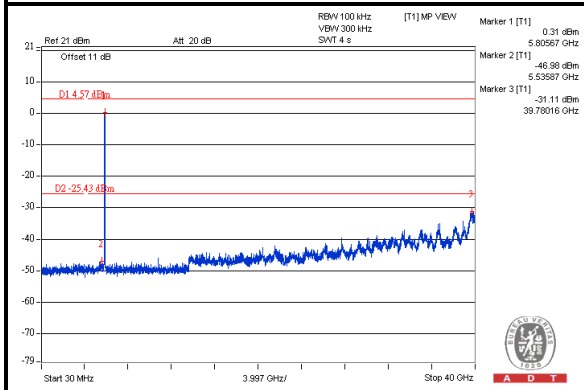



A D T

6. PHOTOGRAPHS OF THE TEST CONFIGURATION

Please refer to the attached file (Test Setup Photo).





7. INFORMATION ON THE TESTING LABORATORIES

We, Bureau Veritas Consumer Products Services (H.K.) Ltd., Taoyuan Branch, were founded in 1988 to provide our best service in EMC, Radio, Telecom and Safety consultation. Our laboratories are accredited and approved according to ISO/IEC 17025.

If you have any comments, please feel free to contact us at the following:

Linko EMC/RF Lab:

Tel: 886-2-26052180

Fax: 886-2-26052943

Hsin Chu EMC/RF Lab:

Tel: 886-3-5935343

Fax: 886-3-5935342

Hwa Ya EMC/RF/Safety/Telecom Lab:

Tel: 886-3-3183232

Fax: 886-3-3270892

Email: service.adt@tw.bureauveritas.com

Web Site: www.bureauveritas-adt.com

The address and road map of all our labs can be found in our web site also.



A D T

8. APPENDIX A - MODIFICATIONS RECORDERS FOR ENGINEERING CHANGES TO THE EUT BY THE LAB

No modifications were made to the EUT by the lab during the test.

--- END ---