

FCC Test Report

Report No.: RF180903E08

FCC ID: YZKECWO5212L

Test Model: ECWO5212-L

Received Date: Sep. 03, 2018

Test Date: Oct. 03 to 10, 2018

Issued Date: Nov. 08, 2018

Applicant: Edgecore Networks Corporation

Address: No.1, Creation 3rd Rd., Hsinchu Science Park, East Dist., Hsinchu City
30077, Taiwan, R.O.C

Issued By: Bureau Veritas Consumer Products Services (H.K.) Ltd., Taoyuan Branch
Hsin Chu Laboratory

Lab Address: E-2, No.1, Li Hsin 1st Road, Hsinchu Science Park, Hsinchu City 300,
Taiwan R.O.C.

Test Location : E-2, No.1, Li Hsin 1st Road, Hsinchu Science Park, Hsinchu City 300,
Taiwan R.O.C.

**FCC Registration /
Designation Number:** 723255 / TW2022



This report is for your exclusive use. Any copying or replication of this report to or for any other person or entity, or use of our name or trademark, is permitted only with our prior written permission. This report sets forth our findings solely with respect to the test samples identified herein. The results set forth in this report are not indicative or representative of the quality or characteristics of the lot from which a test sample was taken or any similar or identical product unless specifically and expressly noted. Our report includes all of the tests requested by you and the results thereof based upon the information that you provided to us. You have 60 days from date of issuance of this report to notify us of any material error or omission caused by our negligence, provided, however, that such notice shall be in writing and shall specifically address the issue you wish to raise. A failure to raise such issue within the prescribed time shall constitute your unqualified acceptance of the completeness of this report, the tests conducted and the correctness of the report contents. Unless specific mention, the uncertainty of measurement has been explicitly taken into account to declare the compliance or non-compliance to the specification. The report must not be used by the client to claim product certification, approval, or endorsement by TAF or any government agencies.

Table of Contents

Release Control Record	4
1 Certificate of Conformity	5
2 Summary of Test Results	6
2.1 Measurement Uncertainty	6
2.2 Modification Record	6
3 General Information	7
3.1 General Description of EUT	7
3.2 Description of Test Modes	9
3.2.1 Test Mode Applicability and Tested Channel Detail	10
3.3 Duty Cycle of Test Signal	12
3.4 Description of Support Units	13
3.4.1 Configuration of System under Test	14
3.5 General Description of Applied Standards	16
4 Test Types and Results	17
4.1 Radiated Emission and Bandedge Measurement	17
4.1.1 Limits of Radiated Emission and Bandedge Measurement	17
4.1.2 Test Instruments	18
4.1.3 Test Procedures	19
4.1.4 Deviation from Test Standard	19
4.1.5 Test Setup	20
4.1.6 EUT Operating Conditions	21
4.1.7 Test Results	22
4.2 Conducted Emission Measurement	36
4.2.1 Limits of Conducted Emission Measurement	36
4.2.2 Test Instruments	36
4.2.3 Test Procedures	37
4.2.4 Deviation from Test Standard	37
4.2.5 Test Setup	37
4.2.6 EUT Operating Conditions	37
4.2.7 Test Results	38
4.3 6dB Bandwidth Measurement	40
4.3.1 Limits of 6dB Bandwidth Measurement	40
4.3.2 Test Setup	40
4.3.3 Test Instruments	40
4.3.4 Test Procedure	40
4.3.5 Deviation from Test Standard	40
4.3.6 EUT Operating Conditions	40
4.3.7 Test Result	41
4.4 Occupied Bandwidth Measurement	43
4.4.1 Test Setup	43
4.4.2 Test Instruments	43
4.4.3 Test Procedure	43
4.4.4 Deviation from Test Standard	43
4.4.5 EUT Operating Conditions	43
4.4.6 Test Results	44
4.5 Conducted Output Power Measurement	46
4.5.1 Limits of Conducted Output Power Measurement	46
4.5.2 Test Setup	46
4.5.3 Test Instruments	46
4.5.4 Test Procedures	46
4.5.5 Deviation from Test Standard	46
4.5.6 EUT Operating Conditions	46
4.5.7 Test Results	47

4.6	Power Spectral Density Measurement.....	49
4.6.1	Limits of Power Spectral Density Measurement	49
4.6.2	Test Setup.....	49
4.6.3	Test Instruments	49
4.6.4	Test Procedure	49
4.6.5	Deviation from Test Standard	49
4.6.6	EUT Operating Condition	49
4.6.7	Test Results	50
4.7	Conducted Out of Band Emission Measurement.....	53
4.7.1	Limits of Conducted Out of Band Emission Measurement.....	53
4.7.2	Test Setup.....	53
4.7.3	Test Instruments	53
4.7.4	Test Procedure	53
4.7.5	Deviation from Test Standard	53
4.7.6	EUT Operating Condition	53
4.7.7	Test Results	53
5	Pictures of Test Arrangements.....	62
	Appendix – Information on the Testing Laboratories	63

Release Control Record

Issue No.	Description	Date Issued
RF180903E08	Original release.	Nov. 08, 2018

1 Certificate of Conformity

Product: 11ac dual band IP68 Access Point with external antenna

Brand: Edgecore

Test Model: ECWO5212-L

Sample Status: ENGINEERING SAMPLE

Applicant: Edgecore Networks Corporation

Test Date: Oct. 03 to 10, 2018

Standards: 47 CFR FCC Part 15, Subpart C (Section 15.247)
ANSI C63.10: 2013

The above equipment has been tested by **Bureau Veritas Consumer Products Services (H.K.) Ltd., Taoyuan Branch**, and found compliance with the requirement of the above standards. The test record, data evaluation & Equipment Under Test (EUT) configurations represented herein are true and accurate accounts of the measurements of the sample's EMC characteristics under the conditions specified in this report.

Prepared by : Mary Ko , **Date:** Nov. 08, 2018
Mary Ko / Specialist

Approved by : May Chen , **Date:** Nov. 08, 2018
May Chen / Manager

2 Summary of Test Results

47 CFR FCC Part 15, Subpart C (Section 15.247)			
FCC Clause	Test Item	Result	Remarks
15.207	AC Power Conducted Emission	PASS	Meet the requirement of limit. Minimum passing margin is -9.42dB at 0.22031MHz.
15.205 / 15.209 / 15.247(d)	Radiated Emissions and Band Edge Measurement	PASS	Meet the requirement of limit. Minimum passing margin is -0.1dB at 2483.50MHz, 2498.80MHz.
15.247(d)	Antenna Port Emission	PASS	Meet the requirement of limit.
15.247(a)(2)	6dB bandwidth	PASS	Meet the requirement of limit.
15.247(b)	Conducted power	PASS	Meet the requirement of limit.
15.247(e)	Power Spectral Density	PASS	Meet the requirement of limit.
15.203	Antenna Requirement	PASS	No antenna connector is used.
-	Occupied Bandwidth Measurement	-	Reference only

2.1 Measurement Uncertainty

Where relevant, the following measurement uncertainty levels have been estimated for tests performed on the EUT as specified in CISPR 16-4-2:

Measurement	Frequency	Expanded Uncertainty (k=2) (\pm)
Conducted Emissions at mains ports	150kHz ~ 30MHz	1.84 dB
Radiated Emissions up to 1 GHz	30MHz ~ 1GHz	5.33 dB
Radiated Emissions above 1 GHz	1GHz ~ 6GHz	5.10 dB
	6GHz ~ 18GHz	4.85 dB
	18GHz ~ 40GHz	5.24 dB

2.2 Modification Record

There were no modifications required for compliance.

3 General Information

3.1 General Description of EUT

Product	11ac dual band IP68 Access Point with external antenna
Brand	Edgecore
Test Model	ECWO5212-L
Status of EUT	ENGINEERING SAMPLE
Power Supply Rating	48Vdc from POE
Modulation Type	CCK, DQPSK, DBPSK for DSSS 64QAM, 16QAM, QPSK, BPSK for OFDM 256QAM for OFDM in 11ac mode only
Modulation Technology	DSSS, OFDM
Transfer Rate	802.11b: up to 11Mbps 802.11a/g: up to 54Mbps 802.11n: up to 300Mbps 802.11ac: up to 866.7Mbps
Operating Frequency	2.4GHz: 2.412 ~ 2.462GHz 5GHz: 5.18GHz ~ 5.24GHz, 5.745GHz ~ 5.825GHz
Number of Channel	2.4GHz: 802.11b, 802.11g, 802.11n (HT20): 11 802.11n (HT40): 7 5GHz: 802.11a, 802.11n (HT20), 802.11ac (VHT20): 9 802.11n (HT40), 802.11ac (VHT40): 4 802.11ac (VHT80): 2
Output Power	2.4GHz: 491.547mW 5.18 ~ 5.24GHz: 520.72mW 5.745 ~ 5.825GHz: 396.962mW
Antenna Type	Refer to Note
Antenna Connector	Refer to Note
Accessory Device	NA
Data Cable Supplied	NA

Note:

1. The EUT has below radios as following table:

Radio 1	Radio 2
WLAN (2.4GHz) - Internal Antenna	WLAN (5GHz) - External Antenna

2. Simultaneously transmission condition.

Condition	Technology	
1	WLAN (2.4GHz) - Internal Antenna	WLAN (5GHz) - External Antenna

Note: The emission of the simultaneous operation has been evaluated and no non-compliance was found.

3. The EUT must be supplied with a POE as following table:

POE (Only for test not for sale)			
No.	Brand	Model No.	Spec.
1	GOSPELL DIGITAL TECHNOLOGY CO.,LTD	G0720-480-050	Input: 100-240Vac, 0.75 Max, 50/60Hz Output: 48Vdc, 0.5A

4. The antennas provided to the EUT, please refer to the following table:

Antenna No.	Chain No.	Antenna Net Gain (dBi)	Frequency range (GHz)	Antenna Type	Connector Type	Cable Length (mm)
Internal Antenna	2.4G Chain0	4.5	2.4~2.4835	Print PCB	NA	-
	2.4G Chain1	5.4	2.4~2.4835	Print PCB	NA	-
External Antenna	5G Chain0	5.58	5.15~5.85	Dipole	R-SMA	260
	5G Chain1	5.58	5.15~5.85	Dipole	R-SMA	100

5. The EUT incorporates a MIMO function.

2.4GHz Band		
MODULATION MODE	DATA RATE (MCS)	TX & RX CONFIGURATION
802.11b	1 ~ 11Mbps	2TX 2RX
802.11g	6 ~ 54Mbps	2TX 2RX
802.11n (HT20)	MCS 0~7	2TX 2RX
	MCS 8~15	2TX 2RX
802.11n (HT40)	MCS 0~7	2TX 2RX
	MCS 8~15	2TX 2RX
5GHz Band		
MODULATION MODE	DATA RATE (MCS)	TX & RX CONFIGURATION
802.11a	6 ~ 54Mbps	2TX 2RX
802.11n (HT20)	MCS 0~7	2TX 2RX
	MCS 8~15	2TX 2RX
802.11n (HT40)	MCS 0~7	2TX 2RX
	MCS 8~15	2TX 2RX
802.11ac (VHT20)	MCS 0~8, Nss=1	2TX 2RX
	MCS 0~8, Nss=2	2TX 2RX
802.11ac (VHT40)	MCS 0~9, Nss=1	2TX 2RX
	MCS 0~9, Nss=2	2TX 2RX
802.11ac (VHT80)	MCS 0~9, Nss=1	2TX 2RX
	MCS 0~9, Nss=2	2TX 2RX

6. The above EUT information is declared by manufacturer and for more detailed features description, please refer to the manufacturer's specifications or user's manual.

3.2 Description of Test Modes

11 channels are provided for 802.11b, 802.11g and 802.11n (HT20):

Channel	Frequency	Channel	Frequency
1	2412MHz	7	2442MHz
2	2417MHz	8	2447MHz
3	2422MHz	9	2452MHz
4	2427MHz	10	2457MHz
5	2432MHz	11	2462MHz
6	2437MHz		

7 channels are provided for 802.11n (HT40):

Channel	Frequency	Channel	Frequency
3	2422MHz	7	2442MHz
4	2427MHz	8	2447MHz
5	2432MHz	9	2452MHz
6	2437MHz		

3.2.1 Test Mode Applicability and Tested Channel Detail

EUT CONFIGURE MODE	APPLICABLE TO				DESCRIPTION
	RE \geq 1G	RE<1G	PLC	APCM	
-	√	√	√	√	-

Where **RE \geq 1G**: Radiated Emission above 1GHz & Bandedge Measurement
RE<1G: Radiated Emission below 1GHz
PLC: Power Line Conducted Emission
APCM: Antenna Port Conducted Measurement

Radiated Emission Test (Above 1GHz):

- Pre-Scan has been conducted to determine the worst-case mode from all possible combinations between available modulations, data rates and antenna ports (if EUT with antenna diversity architecture).
- Following channel(s) was (were) selected for the final test as listed below.

MODE	AVAILABLE CHANNEL	TESTED CHANNEL	MODULATION TECHNOLOGY	MODULATION TYPE	DATA RATE (Mbps)
802.11b	1 to 11	1, 6, 11	DSSS	DBPSK	1
802.11g	1 to 11	1, 6, 11	OFDM	BPSK	6
802.11n (HT20)	1 to 11	1, 6, 11	OFDM	BPSK	6.5
802.11n (HT40)	3 to 9	3, 6, 9	OFDM	BPSK	13.5

Radiated Emission Test (Below 1GHz):

- Pre-Scan has been conducted to determine the worst-case mode from all possible combinations between available modulations, data rates and antenna ports (if EUT with antenna diversity architecture).
- Following channel(s) was (were) selected for the final test as listed below.

MODE	AVAILABLE CHANNEL	TESTED CHANNEL	MODULATION TECHNOLOGY	MODULATION TYPE	DATA RATE (Mbps)
802.11g	1 to 11	1	OFDM	BPSK	6

Power Line Conducted Emission Test:

- Pre-Scan has been conducted to determine the worst-case mode from all possible combinations between available modulations, data rates and antenna ports (if EUT with antenna diversity architecture).
- Following channel(s) was (were) selected for the final test as listed below.

MODE	AVAILABLE CHANNEL	TESTED CHANNEL	MODULATION TECHNOLOGY	MODULATION TYPE	DATA RATE (Mbps)
802.11g	1 to 11	1	OFDM	BPSK	6

Antenna Port Conducted Measurement:

- This item includes all test value of each mode, but only includes spectrum plot of worst value of each mode.
- Pre-Scan has been conducted to determine the worst-case mode from all possible combinations between available modulations, data rates and antenna ports (if EUT with antenna diversity architecture).
- Following channel(s) was (were) selected for the final test as listed below.

MODE	AVAILABLE CHANNEL	TESTED CHANNEL	MODULATION TECHNOLOGY	MODULATION TYPE	DATA RATE (Mbps)
802.11b	1 to 11	1, 6, 11	DSSS	DBPSK	1
802.11g	1 to 11	1, 6, 11	OFDM	BPSK	6
802.11n (HT20)	1 to 11	1, 6, 11	OFDM	BPSK	6.5
802.11n (HT40)	3 to 9	3, 6, 9	OFDM	BPSK	13.5

Test Condition:

Applicable To	Environmental Conditions	Input Power (system)	Tested By
RE \geq 1G	22deg. C, 65%RH	120Vac, 60Hz	Steven Chiang
RE $<$ 1G	21deg. C, 66%RH	120Vac, 60Hz	Steven Chiang
PLC	25deg. C, 75%RH	120Vac, 60Hz	Andy Ho
APCM	25deg. C, 60%RH	120Vac, 60Hz	Anderson Chen

3.3 Duty Cycle of Test Signal

If duty cycle of test signal is $\geq 98\%$, duty factor is not required.

If duty cycle of test signal is $< 98\%$, duty factor shall be considered.

802.11b: Duty cycle = $12.238/12.3 = 0.995$

802.11g: Duty cycle = $2.021/2.092 = 0.966$, Duty factor = $10 * \log(1/0.966) = 0.15$

802.11n (HT20): Duty cycle = $1.888/1.956 = 0.965$, Duty factor = $10 * \log(1/0.965) = 0.15$

802.11n (HT40): Duty cycle = $0.926/0.966 = 0.959$, Duty factor = $10 * \log(1/0.959) = 0.18$

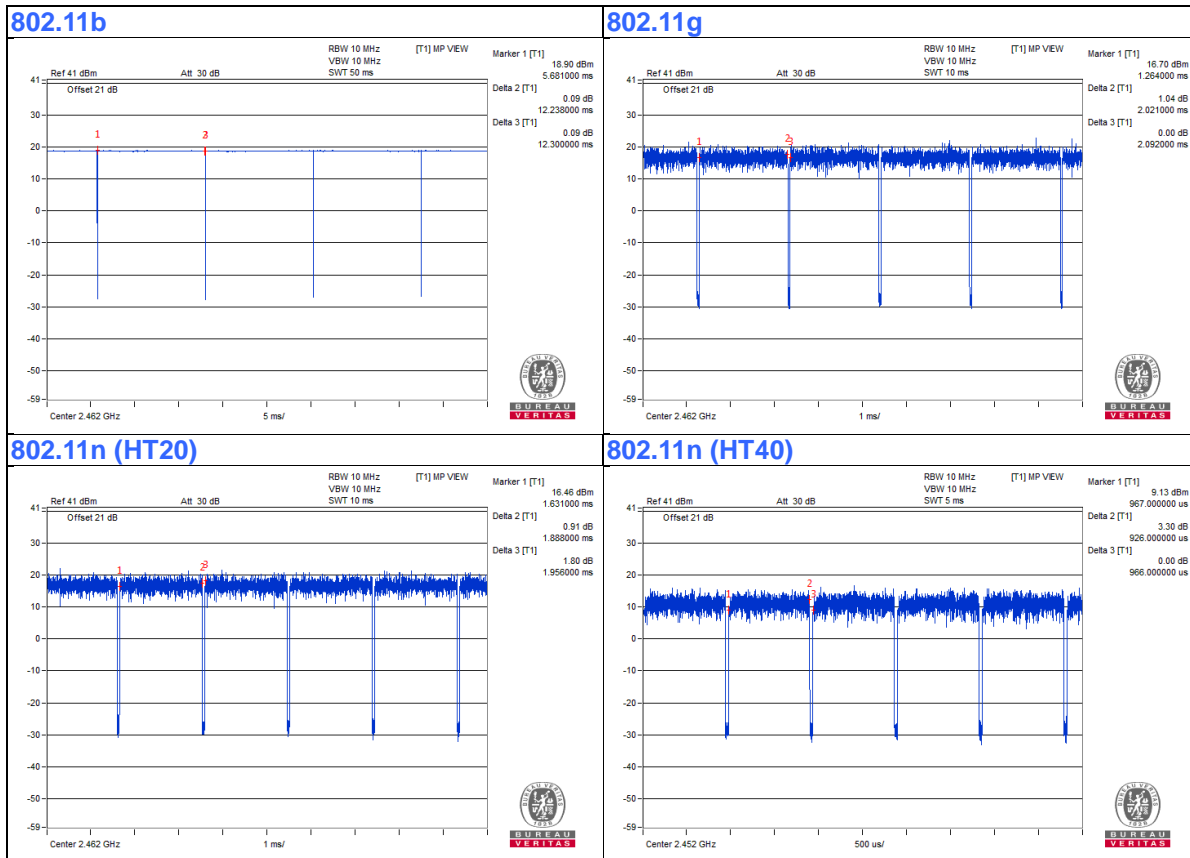

3.4 Description of Support Units

The EUT has been tested as an independent unit together with other necessary accessories or support units. The following support units or accessories were used to form a representative test configuration during the tests.

ID	Product	Brand	Model No.	Serial No.	FCC ID	Remarks
A.	Laptop	DELL	E6420	B92T3R1	FCC DoC	Provided by Lab
B.	Laptop	HP	Pavilion 14-ab023TU	5CD5340WXZ	NA	Provided by Lab
C.	POE Adapter	GOSPELL DIGITAL TECHNOLOGY CO.,LTD	G0720-480-050	NA	NA	Supplied by client

Note:

1. All power cords of the above support units are non-shielded (1.8m).

ID	Descriptions	Qty.	Length (m)	Shielding (Yes/No)	Cores (Qty.)	Remarks
1.	RJ-45 Cable	1	10	No	0	Provided by Lab
2.	RJ-45 Cable	1	10	No	0	Provided by Lab
3.	RJ-45 Cable	1	1	No	0	Provided by Lab
4.	AC Cable	1	1.8	No	0	Supplied by client
5.	Grounding cable	1	1.8	No	0	Provided by Lab

3.4.1 Configuration of System under Test

For conducted emission test:

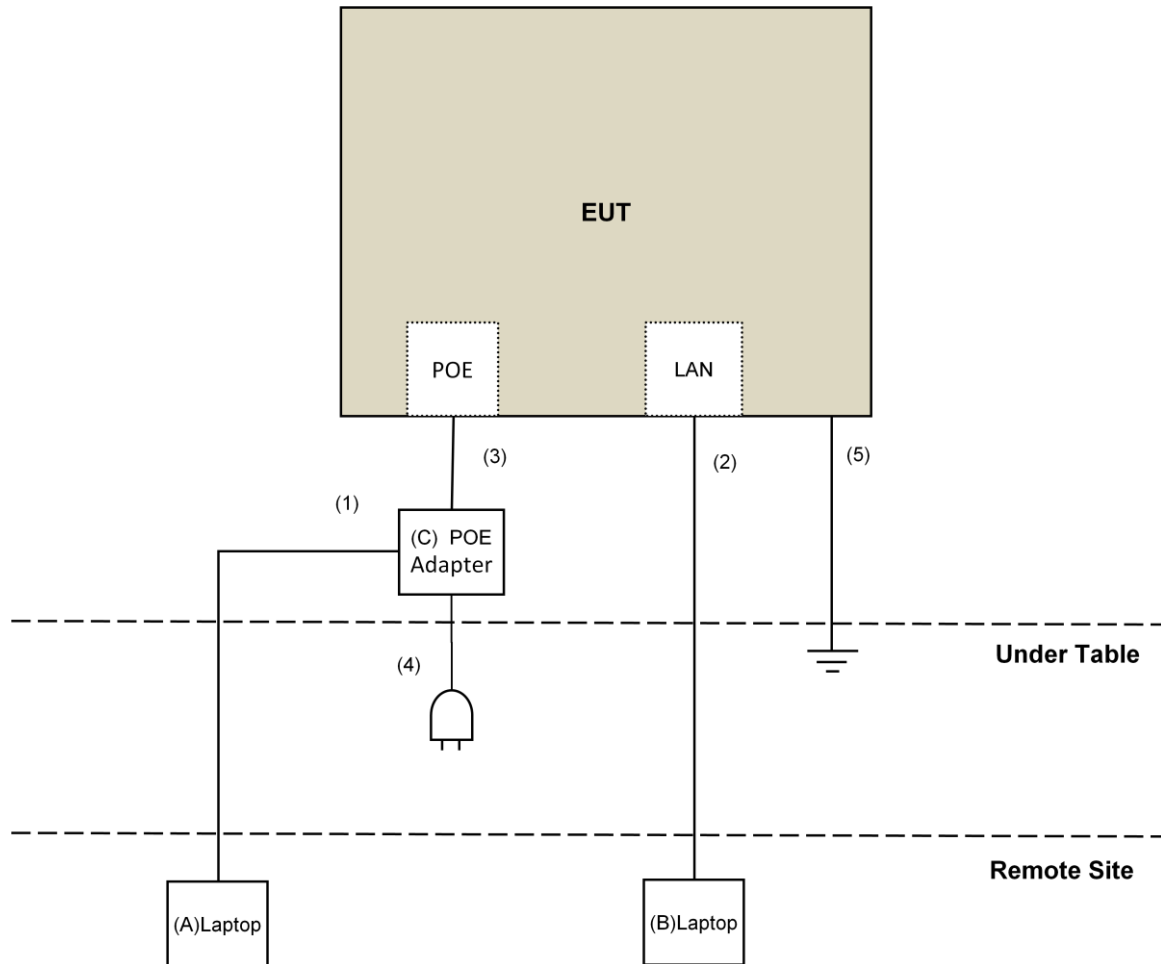

For radiated emission test:

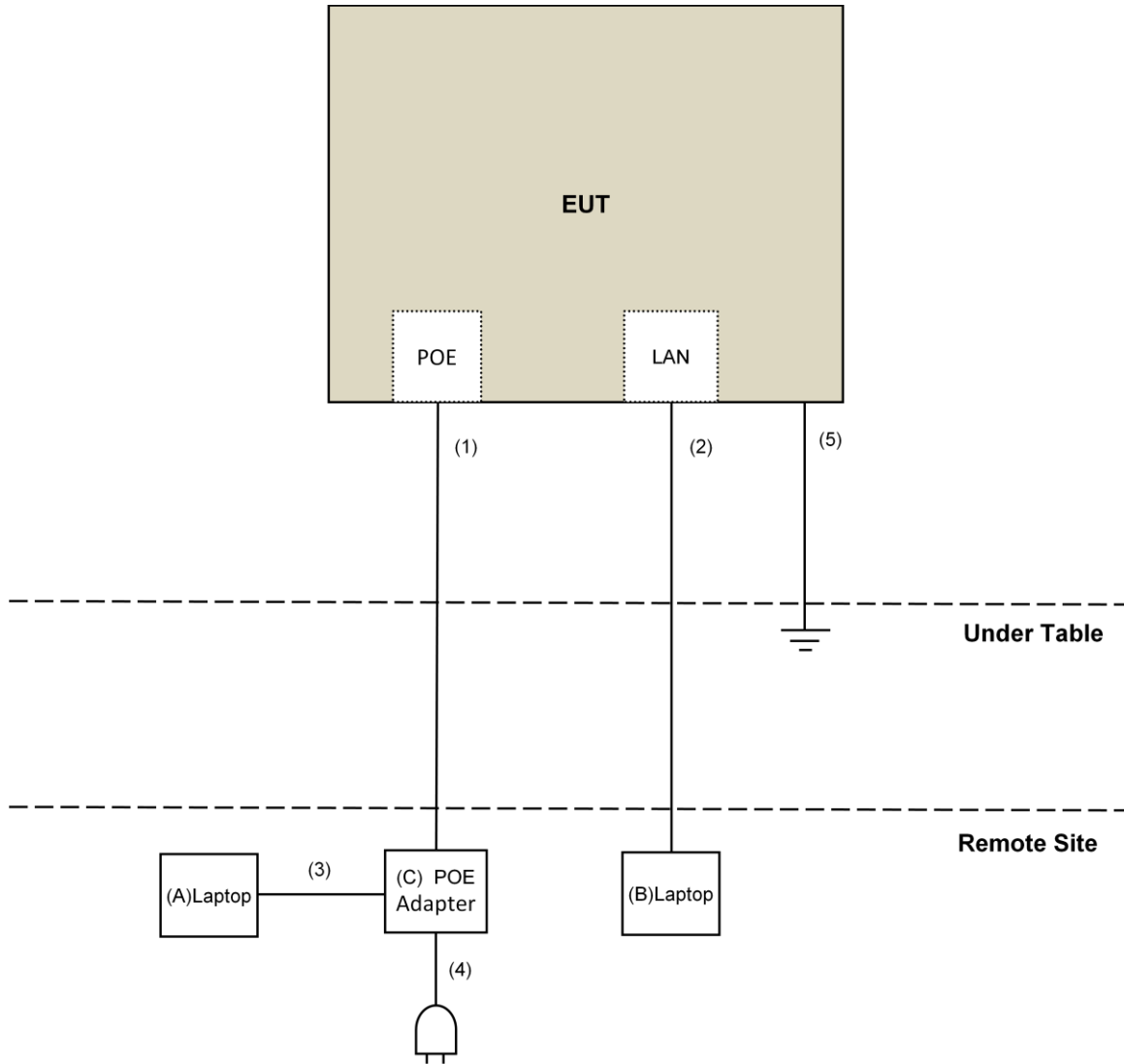

3.5 General Description of Applied Standards

The EUT is a RF Product. According to the specifications of the manufacturer, it must comply with the requirements of the following standards:

FCC Part 15, Subpart C (15.247)
KDB 558074 D01 15.247 Meas Guidance v05
KDB 662911 D01 Multiple Transmitter Output v02r01
ANSI C63.10-2013

All test items have been performed and recorded as per the above standards.

4 Test Types and Results

4.1 Radiated Emission and Bandedge Measurement

4.1.1 Limits of Radiated Emission and Bandedge Measurement

Radiated emissions which fall in the restricted bands must comply with the radiated emission limits specified as below table. Other emissions shall be at least 20dB below the highest level of the desired power:

Frequencies (MHz)	Field Strength (microvolts/meter)	Measurement Distance (meters)
0.009 ~ 0.490	2400/F(kHz)	300
0.490 ~ 1.705	24000/F(kHz)	30
1.705 ~ 30.0	30	30
30 ~ 88	100	3
88 ~ 216	150	3
216 ~ 960	200	3
Above 960	500	3

NOTE:

1. The lower limit shall apply at the transition frequencies.
2. Emission level (dBuV/m) = 20 log Emission level (uV/m).
3. For frequencies above 1000MHz, the field strength limits are based on average detector, however, the peak field strength of any emission shall not exceed the maximum permitted average limits, specified above by more than 20dB under any condition of modulation.

4.1.2 Test Instruments

DESCRIPTION & MANUFACTURER	MODEL NO.	SERIAL NO.	CALIBRATED DATE	CALIBRATED UNTIL
Test Receiver Keysight	N9038A	MY54450088	July 05, 2018	July 04, 2019
Pre-Amplifier EMCI	EMC001340	980142	Feb. 09, 2018	Feb. 08, 2019
Loop Antenna ^(*) Electro-Metrics	EM-6879	264	Dec. 16, 2016	Dec. 15, 2018
RF Cable	NA	LOOPCAB-001	Jan. 15, 2018	Jan. 14, 2019
RF Cable	NA	LOOPCAB-002	Jan. 15, 2018	Jan. 14, 2019
Pre-Amplifier Mini-Circuits	ZFL-1000VH2B	AMP-ZFL-01	Nov. 09, 2017	Nov. 08, 2018
Trilog Broadband Antenna SCHWARZBECK	VULB 9168	9168-406	Nov. 29, 2017	Nov. 28, 2018
RF Cable	8D	966-4-1	Mar. 21, 2018	Mar. 20, 2019
RF Cable	8D	966-4-2	Mar. 21, 2018	Mar. 20, 2019
RF Cable	8D	966-4-3	Mar. 21, 2018	Mar. 20, 2019
Fixed attenuator Mini-Circuits	UNAT-5+	PAD-3m-4-01	Sep. 27, 2018	Sep. 26, 2019
Horn_Antenna SCHWARZBECK	BBHA 9120D	9120D-783	Dec. 12, 2017	Dec. 11, 2018
Pre-Amplifier Mini-Circuits	ZVA-183-S+	AMP-ZVA-03	May 10, 2018	May 09, 2019
RF Cable	EMC104-SM-SM-1200	160923	Jan. 29, 2018	Jan. 28, 2019
RF Cable	EMC104-SM-SM-2000	150318	Jan. 29, 2018	Jan. 28, 2019
RF Cable	EMC104-SM-SM-5000	150321	Jan. 29, 2018	Jan. 28, 2019
Pre-Amplifier EMCI	EMC184045SE	980387	Jan. 29, 2018	Jan. 28, 2019
Horn_Antenna SCHWARZBECK	BBHA 9170	BBHA9170608	Dec. 14, 2017	Dec. 13, 2018
RF Cable	EMC102-KM-KM-1200	160925	Jan. 29, 2018	Jan. 28, 2019
Software	ADT_Radiated_V8.7.08	NA	NA	NA
Boresight Antenna Tower & Turn Table Max-Full	MF-7802BS	MF780208530	NA	NA
Spectrum Analyzer R&S	FSV40	100964	June 20, 2018	June 19, 2019
Power meter Anritsu	ML2495A	1014008	May 09, 2018	May 08, 2019
Power sensor Anritsu	MA2411B	0917122	May 09, 2018	May 08, 2019

Note:

1. The calibration interval of the above test instruments is 12 months and the calibrations are traceable to NML/ROC and NIST/USA.
2. *The calibration interval of the above test instruments is 24 months and the calibrations are traceable to NML/ROC and NIST/USA.
3. The test was performed in 966 Chamber No. 4.
4. The CANADA Site Registration No. is 20331-2
5. Loop antenna was used for all emissions below 30 MHz.
6. Tested Date: Oct. 03 to 06, 2018

4.1.3 Test Procedures

For Radiated emission below 30MHz

- a. The EUT was placed on the top of a rotating table 0.8 meters above the ground at a 3 meter chamber room. The table was rotated 360 degrees to determine the position of the highest radiation.
- b. The EUT was set 3 meters away from the interference-receiving antenna, which was mounted on the top of a variable-height antenna tower.
- c. Parallel, perpendicular, and ground-parallel orientations of the antenna are set to make the measurement.
- d. For each suspected emission, the EUT was arranged to its worst case and the rotatable table was turned from 0 degrees to 360 degrees to find the maximum reading.
- e. The test-receiver system was set to Quasi-Peak Detect Function and Specified Bandwidth with Maximum Hold Mode.

NOTE:

1. The resolution bandwidth and video bandwidth of test receiver/spectrum analyzer is 9kHz at frequency below 30MHz.

For Radiated emission above 30MHz

- a. The EUT was placed on the top of a rotating table 0.8 meters (for 30MHz ~ 1GHz) / 1.5 meters (for above 1GHz) above the ground at 3 meter chamber room for test. The table was rotated 360 degrees to determine the position of the highest radiation.
- b. The EUT was set 3 meters away from the interference-receiving antenna, which was mounted on the top of a variable-height antenna tower.
- c. The height of antenna is varied from one meter to four meters above the ground to determine the maximum value of the field strength. Both horizontal and vertical polarizations of the antenna are set to make the measurement.
- d. For each suspected emission, the EUT was arranged to its worst case and then the antenna was tuned to heights from 1 meter to 4 meters and the rotatable table was turned from 0 degrees to 360 degrees to find the maximum reading.
- e. The test-receiver system was set to quasi-peak detect function and specified bandwidth with maximum hold mode when the test frequency is below 1 GHz.
- f. The test-receiver system was set to peak and average detects function and specified bandwidth with maximum hold mode when the test frequency is above 1 GHz. If the peak reading value also meets average limit, measurement with the average detector is unnecessary.

Note:

1. The resolution bandwidth and video bandwidth of test receiver/spectrum analyzer is 120kHz for Quasi-peak detection (QP) at frequency below 1GHz.
2. The resolution bandwidth of test receiver/spectrum analyzer is 1 MHz and the video bandwidth is 3 MHz for Peak detection (PK) at frequency above 1GHz.
3. The resolution bandwidth of test receiver/spectrum analyzer is 1MHz and the video bandwidth is $\geq 1/T$ (Duty cycle < 98%) or 10Hz (Duty cycle $\geq 98\%$) for Average detection (AV) at frequency above 1GHz.
4. All modes of operation were investigated and the worst-case emissions are reported.

4.1.4 Deviation from Test Standard

No deviation.

4.1.5 Test Setup

For Radiated emission below 30MHz

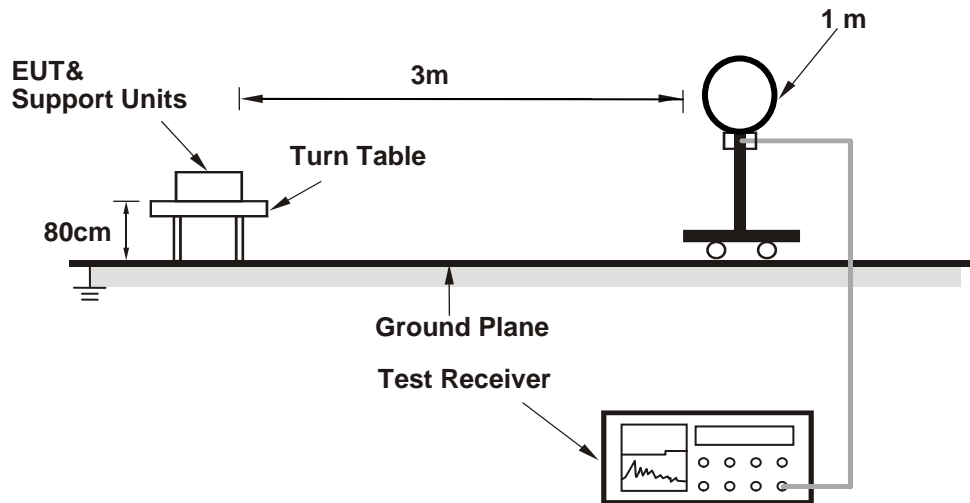

For Radiated emission 30MHz to 1GHz

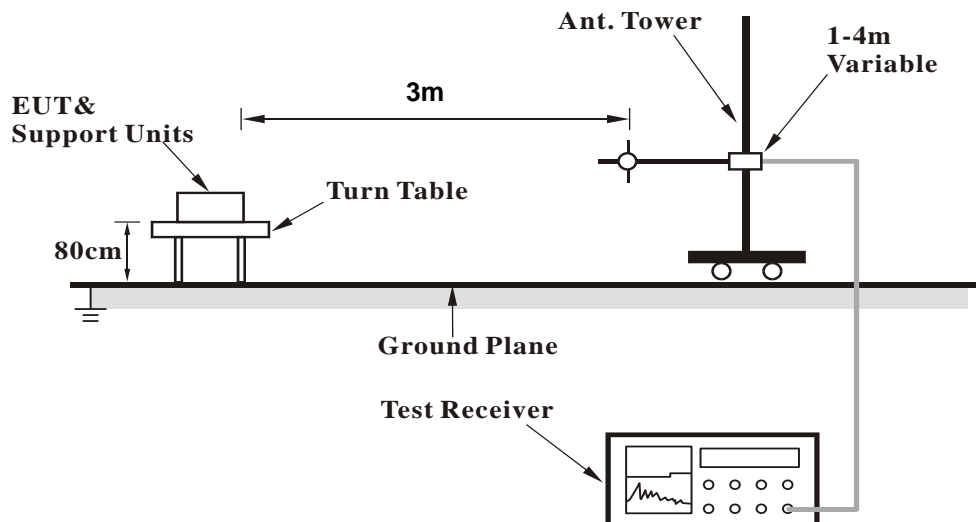

For Radiated emission above 1GHz

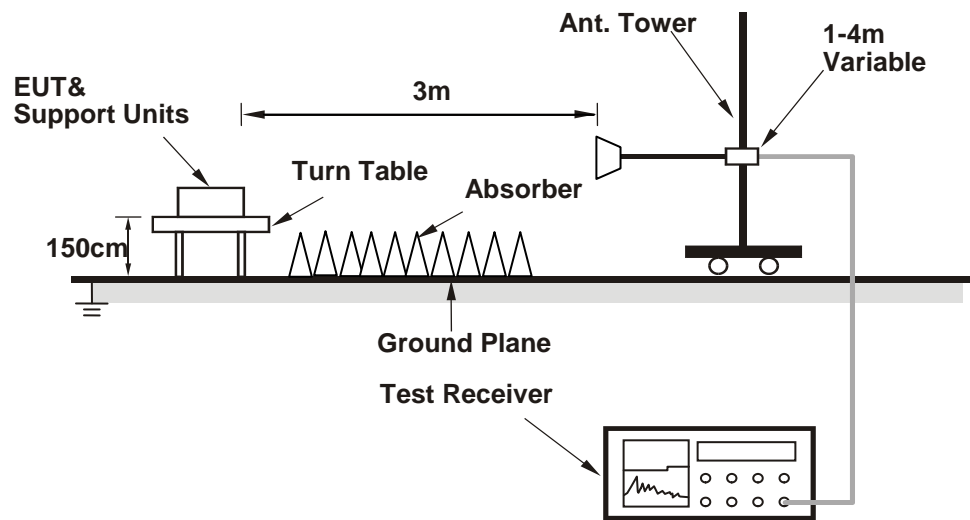

For the actual test configuration, please refer to the attached file (Test Setup Photo).

4.1.6 EUT Operating Conditions

- a. Connected the EUT with the Laptop which is placed on remote site.
- b. Controlling software (Art2-GUI (2.3)) has been activated to set the EUT on specific status.

4.1.7 Test Results

Above 1GHz Data :

802.11b

CHANNEL	TX Channel 1	DETECTOR FUNCTION	Peak (PK)
FREQUENCY RANGE	1GHz ~ 25GHz		Average (AV)

ANTENNA POLARITY & TEST DISTANCE: HORIZONTAL AT 3 M

NO.	FREQ. (MHz)	EMISSION LEVEL (dBuV/m)	LIMIT (dBuV/m)	MARGIN (dB)	ANTENNA HEIGHT (m)	TABLE ANGLE (Degree)	RAW VALUE (dBuV)	CORRECTION FACTOR (dB/m)
1	2373.60	63.6 PK	74.0	-10.4	1.92 H	155	65.7	-2.1
2	2373.60	52.0 AV	54.0	-2.0	1.92 H	155	54.1	-2.1
3	2390.00	62.8 PK	74.0	-11.2	1.92 H	155	65.0	-2.2
4	2390.00	50.7 AV	54.0	-3.3	1.92 H	155	52.9	-2.2
5	*2412.00	109.0 PK			1.92 H	155	111.4	-2.4
6	*2412.00	107.3 AV			1.92 H	155	109.7	-2.4
7	4824.00	54.7 PK	74.0	-19.3	1.38 H	341	52.9	1.8
8	4824.00	53.8 AV	54.0	-0.2	1.38 H	341	52.0	1.8

ANTENNA POLARITY & TEST DISTANCE: VERTICAL AT 3 M

NO.	FREQ. (MHz)	EMISSION LEVEL (dBuV/m)	LIMIT (dBuV/m)	MARGIN (dB)	ANTENNA HEIGHT (m)	TABLE ANGLE (Degree)	RAW VALUE (dBuV)	CORRECTION FACTOR (dB/m)
1	2373.60	63.5 PK	74.0	-10.5	1.65 V	81	65.6	-2.1
2	2373.60	52.6 AV	54.0	-1.4	1.65 V	81	54.7	-2.1
3	2390.00	62.5 PK	74.0	-11.5	1.65 V	81	64.7	-2.2
4	2390.00	50.4 AV	54.0	-3.6	1.65 V	81	52.6	-2.2
5	*2412.00	108.8 PK			1.65 V	81	111.2	-2.4
6	*2412.00	107.2 AV			1.65 V	81	109.6	-2.4
7	4824.00	51.1 PK	74.0	-22.9	1.73 V	4	49.3	1.8
8	4824.00	49.3 AV	54.0	-4.7	1.73 V	4	47.5	1.8

REMARKS:

1. Emission Level(dBuV/m) = Raw Value(dBuV) + Correction Factor(dB/m)
2. Correction Factor(dB/m) = Antenna Factor(dB/m) + Cable Factor(dB) – Pre-Amplifier Factor(dB)
3. The other emission levels were very low against the limit.
4. Margin value = Emission Level – Limit value
5. " * ": Fundamental frequency.

CHANNEL	TX Channel 6	DETECTOR FUNCTION	Peak (PK)
FREQUENCY RANGE	1GHz ~ 25GHz		Average (AV)

ANTENNA POLARITY & TEST DISTANCE: HORIZONTAL AT 3 M

NO.	FREQ. (MHz)	EMISSION LEVEL (dBuV/m)	LIMIT (dBuV/m)	MARGIN (dB)	ANTENNA HEIGHT (m)	TABLE ANGLE (Degree)	RAW VALUE (dBuV)	CORRECTION FACTOR (dB/m)
1	*2437.00	109.3 PK			2.22 H	152	111.9	-2.6
2	*2437.00	107.2 AV			2.22 H	152	109.8	-2.6
3	4874.00	54.9 PK	74.0	-19.1	1.34 H	339	52.9	2.0
4	4874.00	53.8 AV	54.0	-0.2	1.34 H	339	51.8	2.0
5	7311.00	45.3 PK	74.0	-28.7	1.57 H	299	36.9	8.4
6	7311.00	35.3 AV	54.0	-18.7	1.57 H	299	26.9	8.4

ANTENNA POLARITY & TEST DISTANCE: VERTICAL AT 3 M

NO.	FREQ. (MHz)	EMISSION LEVEL (dBuV/m)	LIMIT (dBuV/m)	MARGIN (dB)	ANTENNA HEIGHT (m)	TABLE ANGLE (Degree)	RAW VALUE (dBuV)	CORRECTION FACTOR (dB/m)
1	*2437.00	109.0 PK			1.78 V	77	111.6	-2.6
2	*2437.00	106.8 AV			1.78 V	77	109.4	-2.6
3	4874.00	51.8 PK	74.0	-22.2	1.70 V	357	49.8	2.0
4	4874.00	50.1 AV	54.0	-3.9	1.70 V	357	48.1	2.0
5	7311.00	44.4 PK	74.0	-29.6	1.51 V	11	36.0	8.4
6	7311.00	34.6 AV	54.0	-19.4	1.51 V	11	26.2	8.4

REMARKS:

1. Emission Level(dBuV/m) = Raw Value(dBuV) + Correction Factor(dB/m)
2. Correction Factor(dB/m) = Antenna Factor(dB/m) + Cable Factor(dB) – Pre-Amplifier Factor(dB)
3. The other emission levels were very low against the limit.
4. Margin value = Emission Level – Limit value
5. " * ": Fundamental frequency.

CHANNEL	TX Channel 11	DETECTOR FUNCTION	Peak (PK)
FREQUENCY RANGE	1GHz ~ 25GHz		Average (AV)

ANTENNA POLARITY & TEST DISTANCE: HORIZONTAL AT 3 M

NO.	FREQ. (MHz)	EMISSION LEVEL (dBuV/m)	LIMIT (dBuV/m)	MARGIN (dB)	ANTENNA HEIGHT (m)	TABLE ANGLE (Degree)	RAW VALUE (dBuV)	CORRECTION FACTOR (dB/m)
1	*2462.00	108.7 PK			2.37 H	152	111.3	-2.6
2	*2462.00	106.5 AV			2.37 H	152	109.1	-2.6
3	2483.50	62.8 PK	74.0	-11.2	2.37 H	152	65.2	-2.4
4	2483.50	51.3 AV	54.0	-2.7	2.37 H	152	53.7	-2.4
5	4924.00	54.4 PK	74.0	-19.6	1.05 H	332	52.4	2.0
6	4924.00	53.2 AV	54.0	-0.8	1.05 H	332	51.2	2.0
7	7386.00	44.9 PK	74.0	-29.1	1.55 H	286	36.3	8.6
8	7386.00	34.8 AV	54.0	-19.2	1.55 H	286	26.2	8.6

ANTENNA POLARITY & TEST DISTANCE: VERTICAL AT 3 M

NO.	FREQ. (MHz)	EMISSION LEVEL (dBuV/m)	LIMIT (dBuV/m)	MARGIN (dB)	ANTENNA HEIGHT (m)	TABLE ANGLE (Degree)	RAW VALUE (dBuV)	CORRECTION FACTOR (dB/m)
1	*2462.00	109.3 PK			2.00 V	68	111.9	-2.6
2	*2462.00	107.1 AV			2.00 V	68	109.7	-2.6
3	2483.50	65.7 PK	74.0	-8.3	2.00 V	68	68.1	-2.4
4	2483.50	53.6 AV	54.0	-0.4	2.00 V	68	56.0	-2.4
5	4924.00	50.0 PK	74.0	-24.0	1.78 V	11	48.0	2.0
6	4924.00	48.5 AV	54.0	-5.5	1.78 V	11	46.5	2.0
7	7386.00	43.9 PK	74.0	-30.1	1.46 V	9	35.3	8.6
8	7386.00	34.4 AV	54.0	-19.6	1.46 V	9	25.8	8.6

REMARKS:

1. Emission Level(dBuV/m) = Raw Value(dBuV) + Correction Factor(dB/m)
2. Correction Factor(dB/m) = Antenna Factor(dB/m) + Cable Factor(dB) – Pre-Amplifier Factor(dB)
3. The other emission levels were very low against the limit.
4. Margin value = Emission Level – Limit value
5. " * ": Fundamental frequency.

802.11g

CHANNEL	TX Channel 1	DETECTOR FUNCTION	Peak (PK)
FREQUENCY RANGE	1GHz ~ 25GHz		Average (AV)

ANTENNA POLARITY & TEST DISTANCE: HORIZONTAL AT 3 M

NO.	FREQ. (MHz)	EMISSION LEVEL (dBuV/m)	LIMIT (dBuV/m)	MARGIN (dB)	ANTENNA HEIGHT (m)	TABLE ANGLE (Degree)	RAW VALUE (dBuV)	CORRECTION FACTOR (dB/m)
1	2390.00	67.7 PK	74.0	-6.3	1.48 H	139	69.9	-2.2
2	2390.00	53.7 AV	54.0	-0.3	1.48 H	139	55.9	-2.2
3	*2412.00	112.9 PK			1.48 H	139	115.3	-2.4
4	*2412.00	102.5 AV			1.48 H	139	104.9	-2.4
5	4824.00	60.0 PK	74.0	-14.0	1.19 H	348	58.2	1.8
6	4824.00	47.8 AV	54.0	-6.2	1.19 H	348	46.0	1.8

ANTENNA POLARITY & TEST DISTANCE: VERTICAL AT 3 M

NO.	FREQ. (MHz)	EMISSION LEVEL (dBuV/m)	LIMIT (dBuV/m)	MARGIN (dB)	ANTENNA HEIGHT (m)	TABLE ANGLE (Degree)	RAW VALUE (dBuV)	CORRECTION FACTOR (dB/m)
1	2390.00	66.4 PK	74.0	-7.6	1.60 V	74	68.6	-2.2
2	2390.00	52.3 AV	54.0	-1.7	1.60 V	74	54.5	-2.2
3	*2412.00	112.1 PK			1.60 V	74	114.5	-2.4
4	*2412.00	101.7 AV			1.60 V	74	104.1	-2.4
5	4824.00	55.4 PK	74.0	-18.6	1.64 V	3	53.6	1.8
6	4824.00	42.4 AV	54.0	-11.6	1.64 V	3	40.6	1.8

REMARKS:

1. Emission Level(dBuV/m) = Raw Value(dBuV) + Correction Factor(dB/m)
2. Correction Factor(dB/m) = Antenna Factor(dB/m) + Cable Factor(dB) – Pre-Amplifier Factor(dB)
3. The other emission levels were very low against the limit.
4. Margin value = Emission Level – Limit value
5. " * ": Fundamental frequency.

CHANNEL	TX Channel 6	DETECTOR FUNCTION	Peak (PK)
FREQUENCY RANGE	1GHz ~ 25GHz		Average (AV)

ANTENNA POLARITY & TEST DISTANCE: HORIZONTAL AT 3 M

NO.	FREQ. (MHz)	EMISSION LEVEL (dBuV/m)	LIMIT (dBuV/m)	MARGIN (dB)	ANTENNA HEIGHT (m)	TABLE ANGLE (Degree)	RAW VALUE (dBuV)	CORRECTION FACTOR (dB/m)
1	2390.00	61.1 PK	74.0	-12.9	1.47 H	139	63.3	-2.2
2	2390.00	49.0 AV	54.0	-5.0	1.47 H	139	51.2	-2.2
3	*2437.00	109.8 PK			1.47 H	139	112.4	-2.6
4	*2437.00	99.4 AV			1.47 H	139	102.0	-2.6
5	2483.50	66.7 PK	74.0	-7.3	1.47 H	139	69.1	-2.4
6	2483.50	53.9 AV	54.0	-0.1	1.47 H	139	56.3	-2.4
7	4874.00	59.2 PK	74.0	-14.8	1.24 H	336	57.2	2.0
8	4874.00	46.7 AV	54.0	-7.3	1.24 H	336	44.7	2.0
9	7311.00	45.0 PK	74.0	-29.0	1.57 H	315	36.6	8.4
10	7311.00	34.9 AV	54.0	-19.1	1.57 H	315	26.5	8.4

ANTENNA POLARITY & TEST DISTANCE: VERTICAL AT 3 M

NO.	FREQ. (MHz)	EMISSION LEVEL (dBuV/m)	LIMIT (dBuV/m)	MARGIN (dB)	ANTENNA HEIGHT (m)	TABLE ANGLE (Degree)	RAW VALUE (dBuV)	CORRECTION FACTOR (dB/m)
1	2390.00	59.9 PK	74.0	-14.1	1.67 V	66	62.1	-2.2
2	2390.00	47.7 AV	54.0	-6.3	1.67 V	66	49.9	-2.2
3	*2437.00	109.1 PK			1.67 V	66	111.7	-2.6
4	*2437.00	98.7 AV			1.67 V	66	101.3	-2.6
5	2483.50	66.8 PK	74.0	-7.2	1.67 V	66	69.2	-2.4
6	2483.50	52.5 AV	54.0	-1.5	1.67 V	66	54.9	-2.4
7	4874.00	54.2 PK	74.0	-19.8	1.68 V	12	52.2	2.0
8	4874.00	41.2 AV	54.0	-12.8	1.68 V	12	39.2	2.0
9	7311.00	43.4 PK	74.0	-30.6	1.53 V	22	35.0	8.4
10	7311.00	33.2 AV	54.0	-20.8	1.53 V	22	24.8	8.4

REMARKS:

1. Emission Level(dBuV/m) = Raw Value(dBuV) + Correction Factor(dB/m)
2. Correction Factor(dB/m) = Antenna Factor(dB/m) + Cable Factor(dB) – Pre-Amplifier Factor(dB)
3. The other emission levels were very low against the limit.
4. Margin value = Emission Level – Limit value
5. " * ": Fundamental frequency.

CHANNEL	TX Channel 11	DETECTOR FUNCTION	Peak (PK)
FREQUENCY RANGE	1GHz ~ 25GHz		Average (AV)

ANTENNA POLARITY & TEST DISTANCE: HORIZONTAL AT 3 M

NO.	FREQ. (MHz)	EMISSION LEVEL (dBuV/m)	LIMIT (dBuV/m)	MARGIN (dB)	ANTENNA HEIGHT (m)	TABLE ANGLE (Degree)	RAW VALUE (dBuV)	CORRECTION FACTOR (dB/m)
1	*2462.00	110.4 PK			1.51 H	136	113.0	-2.6
2	*2462.00	100.5 AV			1.51 H	136	103.1	-2.6
3	2483.50	71.8 PK	74.0	-2.2	1.51 H	136	74.2	-2.4
4	2483.50	51.6 AV	54.0	-2.4	1.51 H	136	54.0	-2.4
5	2498.80	69.2 PK	74.0	-4.8	1.51 H	136	71.5	-2.3
6	2498.80	53.9 AV	54.0	-0.1	1.51 H	136	56.2	-2.3
7	4924.00	59.2 PK	74.0	-14.8	1.23 H	345	57.2	2.0
8	4924.00	47.0 AV	54.0	-7.0	1.23 H	345	45.0	2.0
9	7386.00	45.3 PK	74.0	-28.7	1.59 H	314	36.7	8.6
10	7386.00	35.4 AV	54.0	-18.6	1.59 H	314	26.8	8.6

ANTENNA POLARITY & TEST DISTANCE: VERTICAL AT 3 M

NO.	FREQ. (MHz)	EMISSION LEVEL (dBuV/m)	LIMIT (dBuV/m)	MARGIN (dB)	ANTENNA HEIGHT (m)	TABLE ANGLE (Degree)	RAW VALUE (dBuV)	CORRECTION FACTOR (dB/m)
1	*2462.00	109.5 PK			1.60 V	85	112.1	-2.6
2	*2462.00	99.6 AV			1.60 V	85	102.2	-2.6
3	2483.50	70.4 PK	74.0	-3.6	1.60 V	85	72.8	-2.4
4	2483.50	50.2 AV	54.0	-3.8	1.60 V	85	52.6	-2.4
5	2498.80	68.1 PK	74.0	-5.9	1.60 V	85	70.4	-2.3
6	2498.80	52.7 AV	54.0	-1.3	1.60 V	85	55.0	-2.3
7	4924.00	54.6 PK	74.0	-19.4	1.69 V	1	52.6	2.0
8	4924.00	41.4 AV	54.0	-12.6	1.69 V	1	39.4	2.0
9	7386.00	43.6 PK	74.0	-30.4	1.53 V	32	35.0	8.6
10	7386.00	33.5 AV	54.0	-20.5	1.53 V	32	24.9	8.6

REMARKS:

1. Emission Level(dBuV/m) = Raw Value(dBuV) + Correction Factor(dB/m)
2. Correction Factor(dB/m) = Antenna Factor(dB/m) + Cable Factor(dB) – Pre-Amplifier Factor(dB)
3. The other emission levels were very low against the limit.
4. Margin value = Emission Level – Limit value
5. " * ": Fundamental frequency.

802.11n (HT20)

CHANNEL	TX Channel 1	DETECTOR FUNCTION	Peak (PK)
FREQUENCY RANGE	1GHz ~ 25GHz		Average (AV)

ANTENNA POLARITY & TEST DISTANCE: HORIZONTAL AT 3 M

NO.	FREQ. (MHz)	EMISSION LEVEL (dBuV/m)	LIMIT (dBuV/m)	MARGIN (dB)	ANTENNA HEIGHT (m)	TABLE ANGLE (Degree)	RAW VALUE (dBuV)	CORRECTION FACTOR (dB/m)
1	2390.00	66.1 PK	74.0	-7.9	1.67 H	145	68.3	-2.2
2	2390.00	53.7 AV	54.0	-0.3	1.67 H	145	55.9	-2.2
3	*2412.00	112.3 PK			1.67 H	145	114.7	-2.4
4	*2412.00	102.2 AV			1.67 H	145	104.6	-2.4
5	4824.00	58.9 PK	74.0	-15.1	1.23 H	328	57.1	1.8
6	4824.00	46.3 AV	54.0	-7.7	1.23 H	328	44.5	1.8

ANTENNA POLARITY & TEST DISTANCE: VERTICAL AT 3 M

NO.	FREQ. (MHz)	EMISSION LEVEL (dBuV/m)	LIMIT (dBuV/m)	MARGIN (dB)	ANTENNA HEIGHT (m)	TABLE ANGLE (Degree)	RAW VALUE (dBuV)	CORRECTION FACTOR (dB/m)
1	2390.00	66.7 PK	74.0	-7.3	1.67 V	68	68.9	-2.2
2	2390.00	52.4 AV	54.0	-1.6	1.67 V	68	54.6	-2.2
3	*2412.00	111.6 PK			1.67 V	68	114.0	-2.4
4	*2412.00	101.5 AV			1.67 V	68	103.9	-2.4
5	4824.00	54.1 PK	74.0	-19.9	1.74 V	4	52.3	1.8
6	4824.00	40.9 AV	54.0	-13.1	1.74 V	4	39.1	1.8

REMARKS:

1. Emission Level(dBuV/m) = Raw Value(dBuV) + Correction Factor(dB/m)
2. Correction Factor(dB/m) = Antenna Factor(dB/m) + Cable Factor(dB) – Pre-Amplifier Factor(dB)
3. The other emission levels were very low against the limit.
4. Margin value = Emission Level – Limit value
5. " * ": Fundamental frequency.

CHANNEL	TX Channel 6	DETECTOR FUNCTION	Peak (PK)
FREQUENCY RANGE	1GHz ~ 25GHz		Average (AV)

ANTENNA POLARITY & TEST DISTANCE: HORIZONTAL AT 3 M

NO.	FREQ. (MHz)	EMISSION LEVEL (dBuV/m)	LIMIT (dBuV/m)	MARGIN (dB)	ANTENNA HEIGHT (m)	TABLE ANGLE (Degree)	RAW VALUE (dBuV)	CORRECTION FACTOR (dB/m)
1	2390.00	60.3 PK	74.0	-13.7	1.61 H	145	62.5	-2.2
2	2390.00	48.3 AV	54.0	-5.7	1.61 H	145	50.5	-2.2
3	*2437.00	110.0 PK			1.61 H	145	112.6	-2.6
4	*2437.00	99.4 AV			1.61 H	145	102.0	-2.6
5	2483.50	65.8 PK	74.0	-8.2	1.61 H	145	68.2	-2.4
6	2483.50	53.6 AV	54.0	-0.4	1.61 H	145	56.0	-2.4
7	4874.00	59.3 PK	74.0	-14.7	1.26 H	327	57.3	2.0
8	4874.00	46.9 AV	54.0	-7.1	1.26 H	327	44.9	2.0
9	7311.00	45.5 PK	74.0	-28.5	1.63 H	311	37.1	8.4
10	7311.00	35.3 AV	54.0	-18.7	1.63 H	311	26.9	8.4

ANTENNA POLARITY & TEST DISTANCE: VERTICAL AT 3 M

NO.	FREQ. (MHz)	EMISSION LEVEL (dBuV/m)	LIMIT (dBuV/m)	MARGIN (dB)	ANTENNA HEIGHT (m)	TABLE ANGLE (Degree)	RAW VALUE (dBuV)	CORRECTION FACTOR (dB/m)
1	2390.00	58.6 PK	74.0	-15.4	1.67 V	84	60.8	-2.2
2	2390.00	46.6 AV	54.0	-7.4	1.67 V	84	48.8	-2.2
3	*2437.00	109.3 PK			1.67 V	84	111.9	-2.6
4	*2437.00	98.7 AV			1.67 V	84	101.3	-2.6
5	2483.50	66.4 PK	74.0	-7.6	1.67 V	84	68.8	-2.4
6	2483.50	52.1 AV	54.0	-1.9	1.67 V	84	54.5	-2.4
7	4874.00	54.2 PK	74.0	-19.8	1.69 V	23	52.2	2.0
8	4874.00	41.0 AV	54.0	-13.0	1.69 V	23	39.0	2.0
9	7311.00	43.6 PK	74.0	-30.4	1.55 V	19	35.2	8.4
10	7311.00	33.1 AV	54.0	-20.9	1.55 V	19	24.7	8.4

REMARKS:

1. Emission Level(dBuV/m) = Raw Value(dBuV) + Correction Factor(dB/m)
2. Correction Factor(dB/m) = Antenna Factor(dB/m) + Cable Factor(dB) – Pre-Amplifier Factor(dB)
3. The other emission levels were very low against the limit.
4. Margin value = Emission Level – Limit value
5. " * ": Fundamental frequency.

CHANNEL	TX Channel 11	DETECTOR FUNCTION	Peak (PK)
FREQUENCY RANGE	1GHz ~ 25GHz		Average (AV)

ANTENNA POLARITY & TEST DISTANCE: HORIZONTAL AT 3 M

NO.	FREQ. (MHz)	EMISSION LEVEL (dBuV/m)	LIMIT (dBuV/m)	MARGIN (dB)	ANTENNA HEIGHT (m)	TABLE ANGLE (Degree)	RAW VALUE (dBuV)	CORRECTION FACTOR (dB/m)
1	*2462.00	111.5 PK			1.62 H	144	114.1	-2.6
2	*2462.00	101.1 AV			1.62 H	144	103.7	-2.6
3	2483.50	72.2 PK	74.0	-1.8	1.62 H	144	74.6	-2.4
4	2483.50	53.1 AV	54.0	-0.9	1.62 H	144	55.5	-2.4
5	2498.80	67.2 PK	74.0	-6.8	1.62 H	144	69.5	-2.3
6	2498.80	53.9 AV	54.0	-0.1	1.62 H	144	56.2	-2.3
7	4924.00	59.4 PK	74.0	-14.6	1.29 H	326	57.4	2.0
8	4924.00	47.1 AV	54.0	-6.9	1.29 H	326	45.1	2.0
9	7386.00	45.5 PK	74.0	-28.5	1.57 H	312	36.9	8.6
10	7386.00	35.2 AV	54.0	-18.8	1.57 H	312	26.6	8.6

ANTENNA POLARITY & TEST DISTANCE: VERTICAL AT 3 M

NO.	FREQ. (MHz)	EMISSION LEVEL (dBuV/m)	LIMIT (dBuV/m)	MARGIN (dB)	ANTENNA HEIGHT (m)	TABLE ANGLE (Degree)	RAW VALUE (dBuV)	CORRECTION FACTOR (dB/m)
1	*2462.00	111.0 PK			1.69 V	77	113.6	-2.6
2	*2462.00	100.5 AV			1.69 V	77	103.1	-2.6
3	2483.50	69.5 PK	74.0	-4.5	1.69 V	77	71.9	-2.4
4	2483.50	51.8 AV	54.0	-2.2	1.69 V	77	54.2	-2.4
5	2498.80	65.7 PK	74.0	-8.3	1.69 V	77	68.0	-2.3
6	2498.80	52.6 AV	54.0	-1.4	1.69 V	77	54.9	-2.3
7	4924.00	53.9 PK	74.0	-20.1	1.71 V	19	51.9	2.0
8	4924.00	40.9 AV	54.0	-13.1	1.71 V	19	38.9	2.0
9	7386.00	43.6 PK	74.0	-30.4	1.59 V	10	35.0	8.6
10	7386.00	33.2 AV	54.0	-20.8	1.59 V	10	24.6	8.6

REMARKS:

1. Emission Level(dBuV/m) = Raw Value(dBuV) + Correction Factor(dB/m)
2. Correction Factor(dB/m) = Antenna Factor(dB/m) + Cable Factor(dB) – Pre-Amplifier Factor(dB)
3. The other emission levels were very low against the limit.
4. Margin value = Emission Level – Limit value
5. " * ": Fundamental frequency.

802.11n (HT40)

CHANNEL	TX Channel 3	DETECTOR FUNCTION	Peak (PK)
FREQUENCY RANGE	1GHz ~ 25GHz		Average (AV)

ANTENNA POLARITY & TEST DISTANCE: HORIZONTAL AT 3 M								
NO.	FREQ. (MHz)	EMISSION LEVEL (dBuV/m)	LIMIT (dBuV/m)	MARGIN (dB)	ANTENNA HEIGHT (m)	TABLE ANGLE (Degree)	RAW VALUE (dBuV)	CORRECTION FACTOR (dB/m)
1	2390.00	65.0 PK	74.0	-9.0	1.68 H	143	67.2	-2.2
2	2390.00	53.5 AV	54.0	-0.5	1.68 H	143	55.7	-2.2
3	*2422.00	105.9 PK			1.68 H	143	108.4	-2.5
4	*2422.00	95.5 AV			1.68 H	143	98.0	-2.5
5	4844.00	58.8 PK	74.0	-15.2	1.29 H	339	57.0	1.8
6	4844.00	46.3 AV	54.0	-7.7	1.29 H	339	44.5	1.8
7	7266.00	45.3 PK	74.0	-28.7	1.61 H	321	37.1	8.2
8	7266.00	35.2 AV	54.0	-18.8	1.61 H	321	27.0	8.2

ANTENNA POLARITY & TEST DISTANCE: VERTICAL AT 3 M								
NO.	FREQ. (MHz)	EMISSION LEVEL (dBuV/m)	LIMIT (dBuV/m)	MARGIN (dB)	ANTENNA HEIGHT (m)	TABLE ANGLE (Degree)	RAW VALUE (dBuV)	CORRECTION FACTOR (dB/m)
1	2390.00	64.1 PK	74.0	-9.9	1.66 V	96	66.3	-2.2
2	2390.00	52.6 AV	54.0	-1.4	1.66 V	96	54.8	-2.2
3	*2422.00	105.3 PK			1.66 V	96	107.8	-2.5
4	*2422.00	94.9 AV			1.66 V	96	97.4	-2.5
5	4844.00	54.5 PK	74.0	-19.5	1.65 V	6	52.7	1.8
6	4844.00	41.6 AV	54.0	-12.4	1.65 V	6	39.8	1.8
7	7266.00	44.1 PK	74.0	-29.9	1.53 V	8	35.9	8.2
8	7266.00	33.7 AV	54.0	-20.3	1.53 V	8	25.5	8.2

REMARKS:

1. Emission Level(dBuV/m) = Raw Value(dBuV) + Correction Factor(dB/m)
2. Correction Factor(dB/m) = Antenna Factor(dB/m) + Cable Factor(dB) – Pre-Amplifier Factor(dB)
3. The other emission levels were very low against the limit.
4. Margin value = Emission Level – Limit value
5. " * ": Fundamental frequency.

CHANNEL	TX Channel 6	DETECTOR FUNCTION	Peak (PK)
FREQUENCY RANGE	1GHz ~ 25GHz		Average (AV)

ANTENNA POLARITY & TEST DISTANCE: HORIZONTAL AT 3 M

NO.	FREQ. (MHz)	EMISSION LEVEL (dBuV/m)	LIMIT (dBuV/m)	MARGIN (dB)	ANTENNA HEIGHT (m)	TABLE ANGLE (Degree)	RAW VALUE (dBuV)	CORRECTION FACTOR (dB/m)
1	2390.00	63.5 PK	74.0	-10.5	1.45 H	141	65.7	-2.2
2	2390.00	51.0 AV	54.0	-3.0	1.45 H	141	53.2	-2.2
3	*2437.00	109.1 PK			1.45 H	141	111.7	-2.6
4	*2437.00	98.7 AV			1.45 H	141	101.3	-2.6
5	2483.50	66.6 PK	74.0	-7.4	1.45 H	141	69.0	-2.4
6	2483.50	53.9 AV	54.0	-0.1	1.45 H	141	56.3	-2.4
7	4874.00	60.5 PK	74.0	-13.5	1.21 H	321	58.5	2.0
8	4874.00	48.0 AV	54.0	-6.0	1.21 H	321	46.0	2.0
9	7311.00	45.5 PK	74.0	-28.5	1.52 H	320	37.1	8.4
10	7311.00	35.7 AV	54.0	-18.3	1.52 H	320	27.3	8.4

ANTENNA POLARITY & TEST DISTANCE: VERTICAL AT 3 M

NO.	FREQ. (MHz)	EMISSION LEVEL (dBuV/m)	LIMIT (dBuV/m)	MARGIN (dB)	ANTENNA HEIGHT (m)	TABLE ANGLE (Degree)	RAW VALUE (dBuV)	CORRECTION FACTOR (dB/m)
1	2390.00	62.3 PK	74.0	-11.7	1.61 V	67	64.5	-2.2
2	2390.00	49.8 AV	54.0	-4.2	1.61 V	67	52.0	-2.2
3	*2437.00	108.7 PK			1.61 V	67	111.3	-2.6
4	*2437.00	98.3 AV			1.61 V	67	100.9	-2.6
5	2483.50	65.4 PK	74.0	-8.6	1.61 V	67	67.8	-2.4
6	2483.50	52.7 AV	54.0	-1.3	1.61 V	67	55.1	-2.4
7	4874.00	54.9 PK	74.0	-19.1	1.68 V	12	52.9	2.0
8	4874.00	41.9 AV	54.0	-12.1	1.68 V	12	39.9	2.0
9	7311.00	44.0 PK	74.0	-30.0	1.55 V	7	35.6	8.4
10	7311.00	33.9 AV	54.0	-20.1	1.55 V	7	25.5	8.4

REMARKS:

1. Emission Level(dBuV/m) = Raw Value(dBuV) + Correction Factor(dB/m)
2. Correction Factor(dB/m) = Antenna Factor(dB/m) + Cable Factor(dB) – Pre-Amplifier Factor(dB)
3. The other emission levels were very low against the limit.
4. Margin value = Emission Level – Limit value
5. " * ": Fundamental frequency.

CHANNEL	TX Channel 9	DETECTOR FUNCTION	Peak (PK)
FREQUENCY RANGE	1GHz ~ 25GHz		Average (AV)

ANTENNA POLARITY & TEST DISTANCE: HORIZONTAL AT 3 M

NO.	FREQ. (MHz)	EMISSION LEVEL (dBuV/m)	LIMIT (dBuV/m)	MARGIN (dB)	ANTENNA HEIGHT (m)	TABLE ANGLE (Degree)	RAW VALUE (dBuV)	CORRECTION FACTOR (dB/m)
1	*2452.00	107.0 PK			1.67 H	141	109.6	-2.6
2	*2452.00	96.1 AV			1.67 H	141	98.7	-2.6
3	2483.50	67.3 PK	74.0	-6.7	1.67 H	141	69.7	-2.4
4	2483.50	53.9 AV	54.0	-0.1	1.67 H	141	56.3	-2.4
5	4904.00	59.8 PK	74.0	-14.2	1.22 H	350	57.8	2.0
6	4904.00	47.1 AV	54.0	-6.9	1.22 H	350	45.1	2.0
7	7356.00	45.2 PK	74.0	-28.8	1.61 H	306	36.6	8.6
8	7356.00	35.0 AV	54.0	-19.0	1.61 H	306	26.4	8.6

ANTENNA POLARITY & TEST DISTANCE: VERTICAL AT 3 M

NO.	FREQ. (MHz)	EMISSION LEVEL (dBuV/m)	LIMIT (dBuV/m)	MARGIN (dB)	ANTENNA HEIGHT (m)	TABLE ANGLE (Degree)	RAW VALUE (dBuV)	CORRECTION FACTOR (dB/m)
1	*2452.00	106.7 PK			1.64 V	78	109.3	-2.6
2	*2452.00	95.7 AV			1.64 V	78	98.3	-2.6
3	2483.50	66.1 PK	74.0	-7.9	1.64 V	78	68.5	-2.4
4	2483.50	52.6 AV	54.0	-1.4	1.64 V	78	55.0	-2.4
5	4904.00	53.9 PK	74.0	-20.1	1.62 V	25	51.9	2.0
6	4904.00	41.0 AV	54.0	-13.0	1.62 V	25	39.0	2.0
7	7356.00	43.2 PK	74.0	-30.8	1.55 V	34	34.6	8.6
8	7356.00	33.1 AV	54.0	-20.9	1.55 V	34	24.5	8.6

REMARKS:

1. Emission Level(dBuV/m) = Raw Value(dBuV) + Correction Factor(dB/m)
2. Correction Factor(dB/m) = Antenna Factor(dB/m) + Cable Factor(dB) – Pre-Amplifier Factor(dB)
3. The other emission levels were very low against the limit.
4. Margin value = Emission Level – Limit value
5. " * ": Fundamental frequency.

Below 1GHz Data:

802.11g

CHANNEL	TX Channel 1	DETECTOR FUNCTION	Quasi-Peak (QP)
FREQUENCY RANGE	9kHz ~ 1GHz		

ANTENNA POLARITY & TEST DISTANCE: HORIZONTAL AT 3 M

NO.	FREQ. (MHz)	EMISSION LEVEL (dBuV/m)	LIMIT (dBuV/m)	MARGIN (dB)	ANTENNA HEIGHT (m)	TABLE ANGLE (Degree)	RAW VALUE (dBuV)	CORRECTION FACTOR (dB/m)
1	130.20	39.5 QP	43.5	-4.0	2.00 H	70	48.5	-9.0
2	156.73	36.3 QP	43.5	-7.2	1.50 H	256	43.8	-7.5
3	253.12	33.9 QP	46.0	-12.1	1.00 H	78	42.7	-8.8
4	325.00	33.2 QP	46.0	-12.8	1.00 H	301	39.4	-6.2
5	374.69	37.8 QP	46.0	-8.2	1.00 H	123	42.6	-4.8
6	412.50	32.2 QP	46.0	-13.8	1.00 H	331	36.1	-3.9

REMARKS:

1. Emission Level(dBuV/m) = Raw Value(dBuV) + Correction Factor(dB/m)
2. Correction Factor(dB/m) = Antenna Factor(dB/m) + Cable Factor(dB) – Pre-Amplifier Factor(dB)
3. Margin value = Emission Level – Limit value
4. The emission levels were very low against the limit of frequency range 9kHz~30MHz: the amplitude of spurious emissions attenuated more than 20 dB below the permissible value to be report.

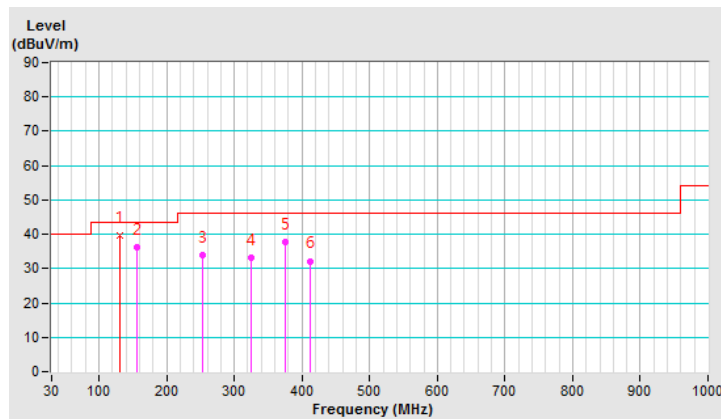

CHANNEL	TX Channel 1	DETECTOR FUNCTION	Quasi-Peak (QP)
FREQUENCY RANGE	9kHz ~ 1GHz		

ANTENNA POLARITY & TEST DISTANCE: VERTICAL AT 3 M

NO.	FREQ. (MHz)	EMISSION LEVEL (dBuV/m)	LIMIT (dBuV/m)	MARGIN (dB)	ANTENNA HEIGHT (m)	TABLE ANGLE (Degree)	RAW VALUE (dBuV)	CORRECTION FACTOR (dB/m)
1	134.13	37.4 QP	43.5	-6.1	1.50 V	215	46.1	-8.7
2	174.99	36.0 QP	43.5	-7.5	1.00 V	165	44.8	-8.8
3	325.00	34.9 QP	46.0	-11.1	1.50 V	135	41.1	-6.2
4	379.88	39.3 QP	46.0	-6.7	1.50 V	136	44.0	-4.7
5	650.00	38.8 QP	46.0	-7.2	1.50 V	360	37.4	1.4
6	934.23	34.7 QP	46.0	-11.3	1.50 V	58	28.7	6.0

REMARKS:

1. Emission Level(dBuV/m) = Raw Value(dBuV) + Correction Factor(dB/m)
2. Correction Factor(dB/m) = Antenna Factor(dB/m) + Cable Factor(dB) – Pre-Amplifier Factor(dB)
3. Margin value = Emission Level – Limit value
4. The emission levels were very low against the limit of frequency range 9kHz~30MHz: the amplitude of spurious emissions attenuated more than 20 dB below the permissible value to be report.

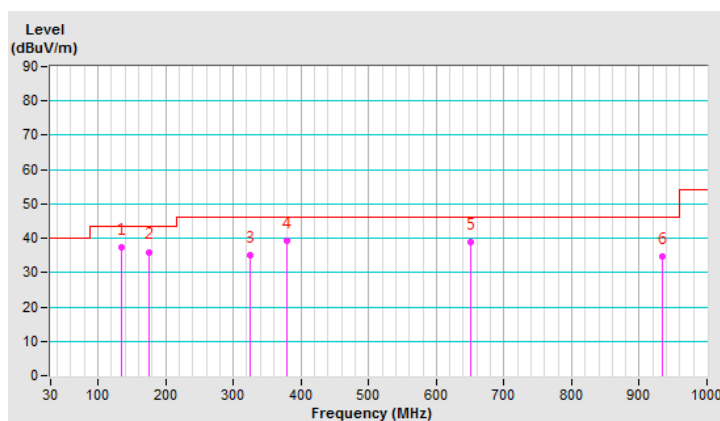

4.2 Conducted Emission Measurement

4.2.1 Limits of Conducted Emission Measurement

Frequency (MHz)	Conducted Limit (dBuV)	
	Quasi-peak	Average
0.15 - 0.5	66 - 56	56 - 46
0.50 - 5.0	56	46
5.0 - 30.0	60	50

Note: 1. The lower limit shall apply at the transition frequencies.

2. The limit decreases in line with the logarithm of the frequency in the range of 0.15 to 0.50MHz.

4.2.2 Test Instruments

DESCRIPTION & MANUFACTURER	MODEL NO.	SERIAL NO.	CALIBRATED DATE	CALIBRATED UNTIL
Test Receiver R&S	ESCS 30	847124/029	Nov. 01, 2017	Oct. 31, 2018
Line-Impedance Stabilization Network (for EUT) R&S	ESH3-Z5	848773/004	Nov. 15, 2017	Nov. 14, 2018
Line-Impedance Stabilization Network (for Peripheral) R&S	ENV216	100072	June 04, 2018	June 03, 2019
50 ohms Terminator	N/A	EMC-04	Nov. 01, 2017	Oct. 31, 2018
RF Cable	5D-FB	COCCAB-001	Sep. 28, 2018	Sep. 27, 2019
Fixed attenuator EMCI	STI02-2200-10	003	Mar. 16, 2018	Mar. 15, 2019
Software BVADT	BVADT_Cond_ V7.3.7.4	NA	NA	NA

Note:

1. The calibration interval of the above test instruments are 12 months and the calibrations are traceable to NML/ROC and NIST/USA.
2. The test was performed in Conduction 1.
3. Tested Date: Oct. 10, 2018

4.2.3 Test Procedures

- The EUT was placed 0.4 meters from the conducting wall of the shielded room with EUT being connected to the power mains through a line impedance stabilization network (LISN). Other support units were connected to the power mains through another LISN. The two LISNs provide 50 ohm/ 50uH of coupling impedance for the measuring instrument.
- Both lines of the power mains connected to the EUT were checked for maximum conducted interference.
- The frequency range from 150kHz to 30MHz was searched. Emission levels under (Limit - 20dB) was not recorded.

NOTE: The resolution bandwidth and video bandwidth of test receiver is 9kHz for quasi-peak detection (QP) and average detection (AV) at frequency 0.15MHz-30MHz.

4.2.4 Deviation from Test Standard

No deviation.

4.2.5 Test Setup

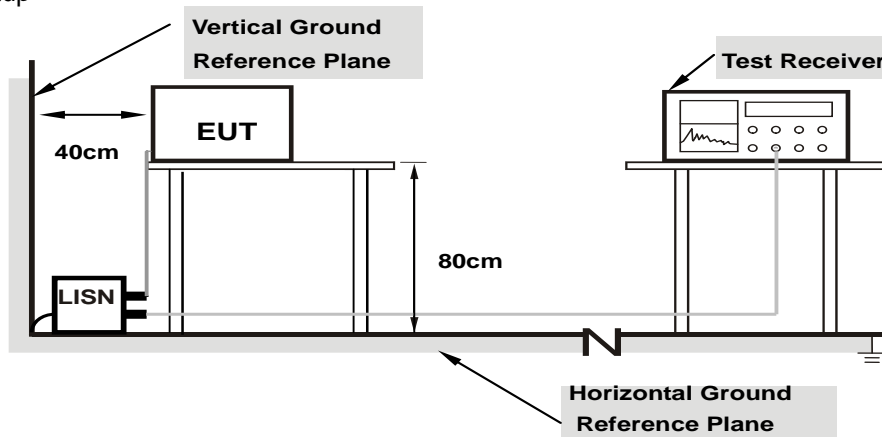

Note: 1.Support units were connected to second LISN.

For the actual test configuration, please refer to the attached file (Test Setup Photo).

4.2.6 EUT Operating Conditions

Same as 4.1.6.

4.2.7 Test Results

Phase	Line (L)	Detector Function	Quasi-Peak (QP) / Average (AV)
-------	----------	-------------------	--------------------------------

No	Freq.	Corr.	Reading Value		Emission Level		Limit		Margin	
	[MHz]	Factor	[dB (uV)]		[dB (uV)]		[dB (uV)]		(dB)	
		(dB)	Q.P.	AV.	Q.P.	AV.	Q.P.	AV.	Q.P.	AV.
1	0.16953	10.04	39.95	25.28	49.99	35.32	64.98	54.98	-14.99	-19.66
2	0.22031	10.07	41.59	33.32	51.66	43.39	62.81	52.81	-11.15	-9.42
3	0.27500	10.08	27.61	10.96	37.69	21.04	60.97	50.97	-23.28	-29.93
4	0.32188	10.09	22.38	3.05	32.47	13.14	59.66	49.66	-27.19	-36.52
5	3.60547	10.25	23.71	10.89	33.96	21.14	56.00	46.00	-22.04	-24.86
6	14.76563	10.82	25.66	20.11	36.48	30.93	60.00	50.00	-23.52	-19.07

REMARKS:

1. Q.P. and AV. are abbreviations of quasi-peak and average individually.
2. The emission levels of other frequencies were very low against the limit.
3. Margin value = Emission level - Limit value
4. Correction factor = Insertion loss + Cable loss
5. Emission Level = Correction Factor + Reading Value.

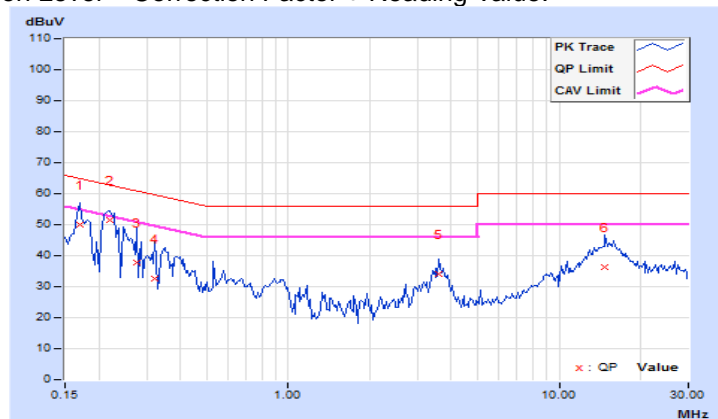

Phase	Neutral (N)	Detector Function	Quasi-Peak (QP) / Average (AV)
-------	-------------	-------------------	--------------------------------

No	Freq. [MHz]	Corr. Factor	Reading Value [dB (uV)]		Emission Level [dB (uV)]		Limit [dB (uV)]		Margin (dB)	
		(dB)	Q.P.	AV.	Q.P.	AV.	Q.P.	AV.	Q.P.	AV.
	1	0.16562	9.95	36.57	17.65	46.52	27.60	65.18	55.18	-18.66
2	0.22031	9.96	39.26	29.45	49.22	39.41	62.81	52.81	-13.59	-13.40
3	0.32188	9.98	18.70	0.89	28.68	10.87	59.66	49.66	-30.98	-38.79
4	0.88828	10.02	15.00	4.03	25.02	14.05	56.00	46.00	-30.98	-31.95
5	3.56250	10.12	24.44	13.27	34.56	23.39	56.00	46.00	-21.44	-22.61
6	17.69141	10.79	24.85	19.62	35.64	30.41	60.00	50.00	-24.36	-19.59

REMARKS:

1. Q.P. and AV. are abbreviations of quasi-peak and average individually.
2. The emission levels of other frequencies were very low against the limit.
3. Margin value = Emission level - Limit value
4. Correction factor = Insertion loss + Cable loss
5. Emission Level = Correction Factor + Reading Value.

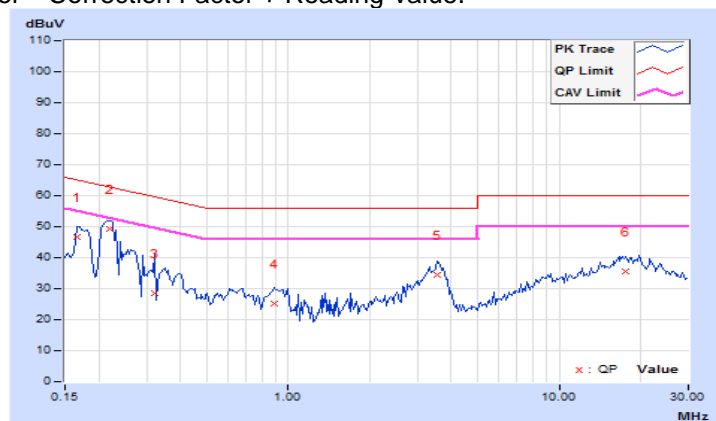

4.3 6dB Bandwidth Measurement

4.3.1 Limits of 6dB Bandwidth Measurement

The minimum of 6dB Bandwidth Measurement is 0.5 MHz.

4.3.2 Test Setup

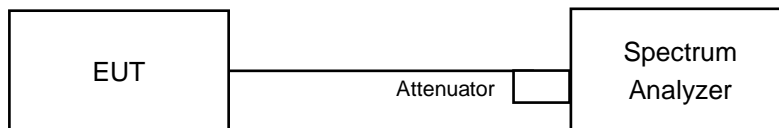

4.3.3 Test Instruments

Refer to section 4.1.2 to get information of above instrument.

4.3.4 Test Procedure

- a. Set resolution bandwidth (RBW) = 100kHz
- b. Set the video bandwidth (VBW) $\geq 3 \times$ RBW, Detector = Peak.
- c. Trace mode = max hold.
- d. Sweep = auto couple.
- e. Measure the maximum width of the emission that is constrained by the frequencies associated with the two amplitude points (upper and lower) that are attenuated by 6 dB relative to the maximum level measured in the fundamental emission

4.3.5 Deviation from Test Standard

No deviation.

4.3.6 EUT Operating Conditions

The software provided by client to enable the EUT under transmission condition continuously at lowest, middle and highest channel frequencies individually.

4.3.7 Test Result

802.11b

Channel	Frequency (MHz)	6dB Bandwidth (MHz)		Minimum Limit (MHz)	Pass / Fail
		Chain 0	Chain 1		
1	2412	7.08	7.10	0.5	Pass
6	2437	7.09	6.62	0.5	Pass
11	2462	7.12	7.05	0.5	Pass

802.11g

Channel	Frequency (MHz)	6dB Bandwidth (MHz)		Minimum Limit (MHz)	Pass / Fail
		Chain 0	Chain 1		
1	2412	15.16	15.16	0.5	Pass
6	2437	15.16	15.14	0.5	Pass
11	2462	15.14	15.11	0.5	Pass

802.11n (HT20)

Channel	Frequency (MHz)	6dB Bandwidth (MHz)		Minimum Limit (MHz)	Pass / Fail
		Chain 0	Chain 1		
1	2412	15.16	15.16	0.5	Pass
6	2437	15.13	15.14	0.5	Pass
11	2462	15.15	15.17	0.5	Pass

802.11n (HT40)

Channel	Frequency (MHz)	6dB Bandwidth (MHz)		Minimum Limit (MHz)	Pass / Fail
		Chain 0	Chain 1		
3	2422	32.67	27.57	0.5	Pass
6	2437	33.85	32.57	0.5	Pass
9	2452	33.85	31.37	0.5	Pass

Spectrum Plot of Worst Value

802.11b / Chain 1 : CH6

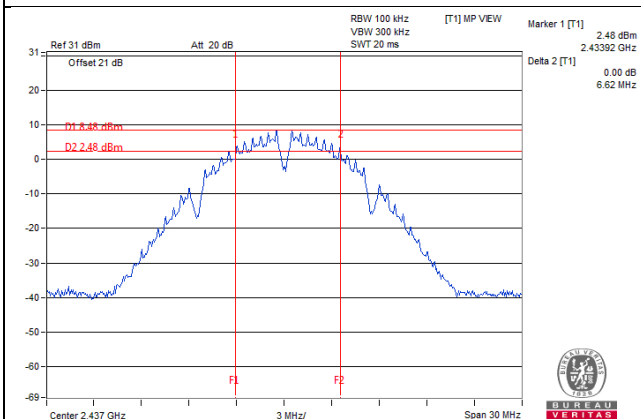

802.11g / Chain 1 : CH11

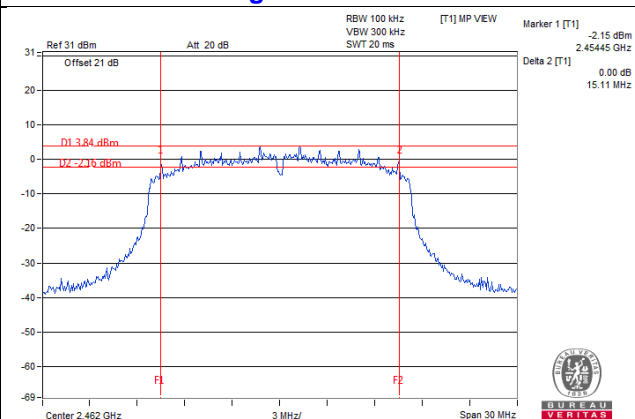

802.11n (HT20) / Chain 0 : CH6

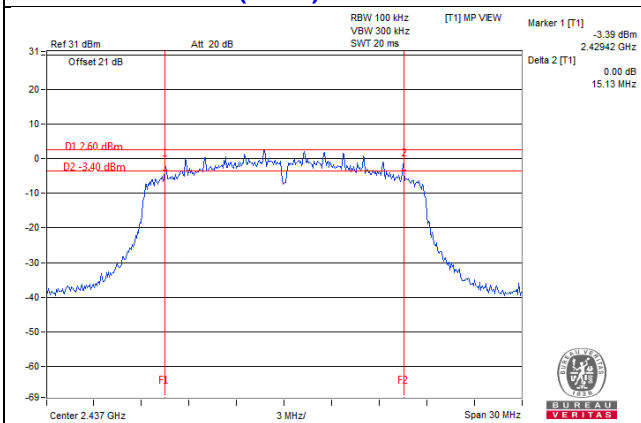

802.11n (HT40) / Chain 1 : CH3

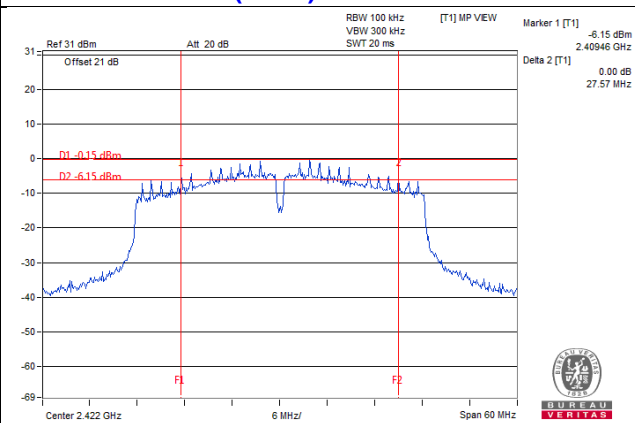

4.4 Occupied Bandwidth Measurement

4.4.1 Test Setup

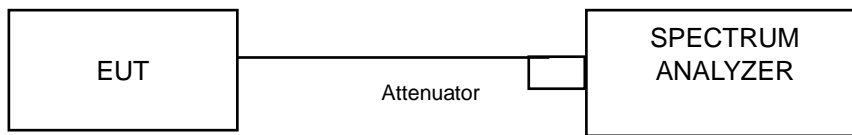

4.4.2 Test Instruments

Refer to section 4.1.2 to get information of above instrument.

4.4.3 Test Procedure

The transmitter output was connected to the spectrum analyzer through an attenuator. The bandwidth of the fundamental frequency was measured by spectrum analyzer with resolution bandwidth in the range of 1% to 5% of the anticipated emission bandwidth, and a video bandwidth at least 3x the resolution bandwidth and set the detector to sampling. The width of a frequency band such that, below the lower and above the upper frequency limits, the mean powers emitted are each equal to a specified percentage 0.5 %of the total mean power of a given emission.

4.4.4 Deviation from Test Standard

No deviation.

4.4.5 EUT Operating Conditions

The software provided by client to enable the EUT under transmission condition continuously at lowest, middle and highest channel frequencies individually.

4.4.6 Test Results

802.11b

Channel	Frequency (MHz)	Occupied Bandwidth (MHz)	
		Chain 0	Chain 1
1	2412	11.88	11.76
6	2437	11.64	11.52
11	2462	12.00	11.16

802.11g

Channel	Frequency (MHz)	Occupied Bandwidth (MHz)	
		Chain 0	Chain 1
1	2412	16.32	16.20
6	2437	16.20	16.20
11	2462	16.20	16.20

802.11n (HT20)

Channel	Frequency (MHz)	Occupied Bandwidth (MHz)	
		Chain 0	Chain 1
1	2412	17.40	17.40
6	2437	17.40	17.40
11	2462	17.52	17.52

802.11n (HT40)

Channel	Frequency (MHz)	Occupied Bandwidth (MHz)	
		Chain 0	Chain 1
3	2422	36.24	36.24
6	2437	36.24	36.00
9	2452	36.24	36.00

Spectrum Plot of Worst Value

802.11b / Chain 0 : CH11

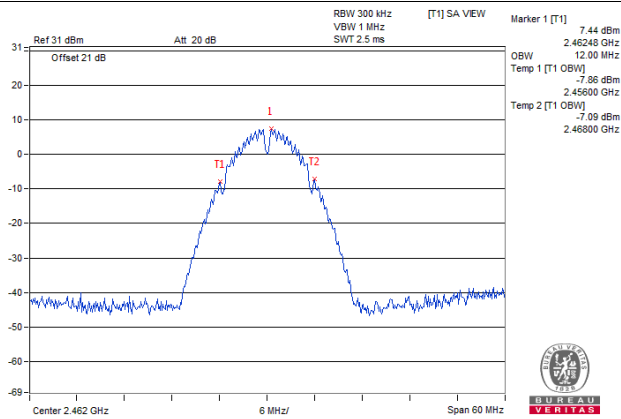

802.11g / Chain 0 : CH1

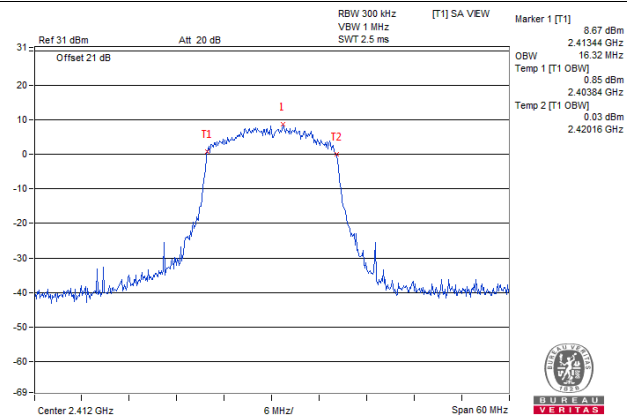

802.11n (HT20) / Chain 0 : CH11

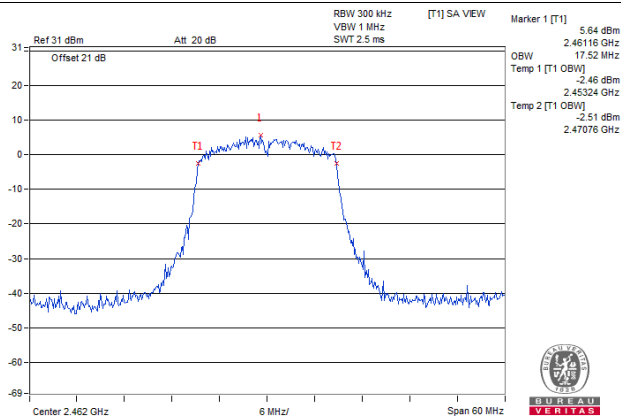

802.11n (HT40) / Chain 0 : CH3

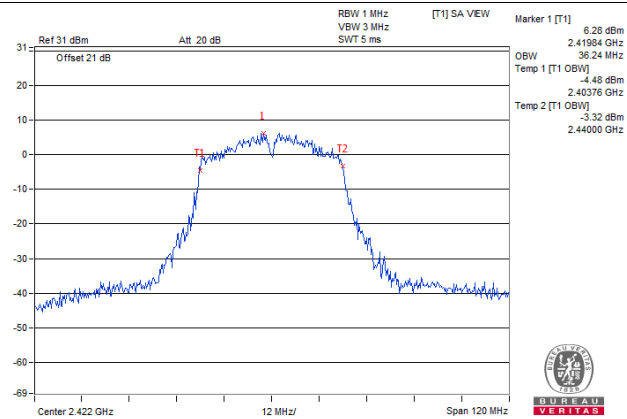

4.5 Conducted Output Power Measurement

4.5.1 Limits of Conducted Output Power Measurement

For systems using digital modulation in the 2400–2483.5 MHz bands: 1 Watt (30dBm)

Per KDB 662911 D01 Multiple Transmitter Output Method of conducted output power measurement on IEEE 802.11 devices,

Array Gain = 0 dB (i.e., no array gain) for $N_{ANT} \leq 4$;

Array Gain = 0 dB (i.e., no array gain) for channel widths ≥ 40 MHz for any N_{ANT} ;

Array Gain = $5 \log(N_{ANT}/N_{SS})$ dB or 3 dB, whichever is less for 20-MHz channel widths with $N_{ANT} \geq 5$.

For power measurements on all other devices: Array Gain = $10 \log(N_{ANT}/N_{SS})$ dB.

4.5.2 Test Setup

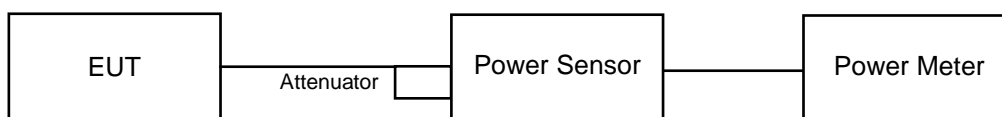

4.5.3 Test Instruments

Refer to section 4.1.2 to get information of above instrument.

4.5.4 Test Procedures

A peak power sensor was used on the output port of the EUT. A power meter was used to read the response of the peak power sensor. Record the power level.

Average power sensor was used to perform output power measurement, trigger and gating function of wide band power meter is enabled to measure max output power of TX on burst. Duty factor is not added to measured value.

4.5.5 Deviation from Test Standard

No deviation.

4.5.6 EUT Operating Conditions

Same as Item 4.3.6.

4.5.7 Test Results

FOR PEAK POWER
802.11b

Chan.	Freq. (MHz)	Peak Power (dBm)		Total Power (mW)	Total Power (dBm)	Limit (dBm)	Pass / Fail
		Chain 0	Chain 1				
1	2412	18.57	18.19	137.862	21.39	30.00	Pass
6	2437	18.83	18.30	143.992	21.58	30.00	Pass
11	2462	17.76	16.95	109.249	20.38	30.00	Pass

802.11g

Chan.	Freq. (MHz)	Peak Power (dBm)		Total Power (mW)	Total Power (dBm)	Limit (dBm)	Pass / Fail
		Chain 0	Chain 1				
1	2412	23.85	23.96	491.547	26.92	30.00	Pass
6	2437	19.80	20.37	204.392	23.10	30.00	Pass
11	2462	21.12	21.00	255.313	24.07	30.00	Pass

802.11n (HT20)

Chan.	Freq. (MHz)	Peak Power (dBm)		Total Power (mW)	Total Power (dBm)	Limit (dBm)	Pass / Fail
		Chain 0	Chain 1				
1	2412	22.65	22.71	370.715	25.69	30.00	Pass
6	2437	18.69	18.90	151.586	21.81	30.00	Pass
11	2462	21.15	20.81	250.821	23.99	30.00	Pass

802.11n (HT40)

Chan.	Freq. (MHz)	Peak Power (dBm)		Total Power (mW)	Total Power (dBm)	Limit (dBm)	Pass / Fail
		Chain 0	Chain 1				
3	2422	17.74	18.23	125.956	21.00	30.00	Pass
6	2437	20.86	23.03	322.808	25.09	30.00	Pass
9	2452	18.32	18.20	133.989	21.27	30.00	Pass

FOR AVERAGE POWER
802.11b

Chan.	Frequency (MHz)	Avg. Power (dBm)		Total Power (mW)	Total Power (dBm)
		Chain 0	Chain 1		
1	2412	15.31	15.02	65.732	18.18
6	2437	15.53	15.48	71.045	18.52
11	2462	14.59	14.17	54.896	17.40

802.11g

Chan.	Frequency (MHz)	Avg. Power (dBm)		Total Power (mW)	Total Power (dBm)
		Chain 0	Chain 1		
1	2412	15.86	16.08	79.099	18.98
6	2437	12.16	12.53	34.35	15.36
11	2462	13.40	13.40	43.756	16.41

802.11n (HT20)

Chan.	Frequency (MHz)	Avg. Power (dBm)		Total Power (mW)	Total Power (dBm)
		Chain 0	Chain 1		
1	2412	14.77	15.37	64.427	18.09
6	2437	11.92	12.05	31.592	15.00
11	2462	12.97	13.01	39.814	16.00

802.11n (HT40)

Chan.	Frequency (MHz)	Avg. Power (dBm)		Total Power (mW)	Total Power (dBm)
		Chain 0	Chain 1		
3	2422	10.80	11.34	25.637	14.09
6	2437	13.88	14.15	50.436	17.03
9	2452	11.15	11.15	26.064	14.16

4.6 Power Spectral Density Measurement

4.6.1 Limits of Power Spectral Density Measurement

The Maximum of Power Spectral Density Measurement is 8dBm in any 3 kHz.

4.6.2 Test Setup

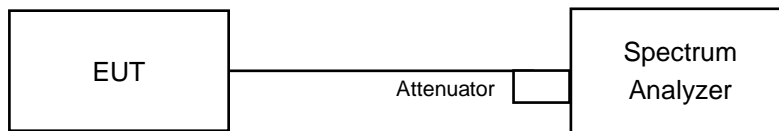

4.6.3 Test Instruments

Refer to section 4.1.2 to get information of above instrument.

4.6.4 Test Procedure

- a. Set analyzer center frequency to DTS channel center frequency.
- b. Set the span to 1.5 times the DTS bandwidth.
- c. Set the RBW to: $3 \text{ kHz} \leq \text{RBW} \leq 100 \text{ kHz}$.
- d. Set the VBW $\geq 3 \times \text{RBW}$.
- e. Detector = peak.
- f. Sweep time = auto couple.
- g. Trace mode = max hold.
- h. Allow trace to fully stabilize.
- i. Use the peak marker function to determine the maximum amplitude level within the RBW.

4.6.5 Deviation from Test Standard

No deviation.

4.6.6 EUT Operating Condition

Same as Item 4.3.6

4.6.7 Test Results

802.11b

TX chain	Channel	Freq. (MHz)	PSD (dBm/3kHz)	10 log (N=2) dB	Total PSD (dBm/3kHz)	Limit (dBm/3kHz)	Pass /Fail
0	1	2412	-6.20	3.01	-3.19	6.03	Pass
	6	2437	-6.08	3.01	-3.07	6.03	Pass
	11	2462	-7.99	3.01	-4.98	6.03	Pass
1	1	2412	-7.15	3.01	-4.14	6.03	Pass
	6	2437	-6.09	3.01	-3.08	6.03	Pass
	11	2462	-6.19	3.01	-3.18	6.03	Pass

Note: 1. Directional gain = $10 \log[(10^{G0/20} + 10^{G1/20})^2 / 2] = 7.97\text{dBi} > 6\text{dBi}$, so the power density limit shall be reduced to $8-(7.97-6) = 6.03\text{dBm}$.

802.11g

TX chain	Channel	Freq. (MHz)	PSD (dBm/3kHz)	10 log (N=2) dB	Total PSD (dBm/3kHz)	Limit (dBm/3kHz)	Pass /Fail
0	1	2412	-8.11	3.01	-5.10	6.03	Pass
	6	2437	-11.45	3.01	-8.44	6.03	Pass
	11	2462	-9.84	3.01	-6.83	6.03	Pass
1	1	2412	-8.26	3.01	-5.25	6.03	Pass
	6	2437	-11.48	3.01	-8.47	6.03	Pass
	11	2462	-9.97	3.01	-6.96	6.03	Pass

Note: 1. Directional gain = $10 \log[(10^{G0/20} + 10^{G1/20})^2 / 2] = 7.97\text{dBi} > 6\text{dBi}$, so the power density limit shall be reduced to $8-(7.97-6) = 6.03\text{dBm}$.

802.11n (HT20)

TX chain	Channel	Freq. (MHz)	PSD (dBm/3kHz)	10 log (N=2) dB	Total PSD (dBm/3kHz)	Limit (dBm/3kHz)	Pass /Fail
0	1	2412	-8.22	3.01	-5.21	6.03	Pass
	6	2437	-11.26	3.01	-8.25	6.03	Pass
	11	2462	-10.76	3.01	-7.75	6.03	Pass
1	1	2412	-9.31	3.01	-6.30	6.03	Pass
	6	2437	-11.37	3.01	-8.36	6.03	Pass
	11	2462	-11.94	3.01	-8.93	6.03	Pass

Note: 1. Directional gain = $10 \log[(10^{G0/20} + 10^{G1/20})^2 / 2] = 7.97\text{dBi} > 6\text{dBi}$, so the power density limit shall be reduced to $8-(7.97-6) = 6.03\text{dBm}$.

802.11n (HT40)

TX chain	Channel	Freq. (MHz)	PSD (dBm/3kHz)	10 log (N=2) dB	Total PSD (dBm/3kHz)	Limit (dBm/3kHz)	Pass /Fail
0	3	2422	-14.86	3.01	-11.85	6.03	Pass
	6	2437	-11.49	3.01	-8.48	6.03	Pass
	9	2452	-14.73	3.01	-11.72	6.03	Pass
1	3	2422	-15.97	3.01	-12.96	6.03	Pass
	6	2437	-13.98	3.01	-10.97	6.03	Pass
	9	2452	-15.39	3.01	-12.38	6.03	Pass

Note: 1. Directional gain = $10 \log[(10^{G0/20} + 10^{G1/20})^2 / 2] = 7.97\text{dBi} > 6\text{dBi}$, so the power density limit shall be reduced to $8 - (7.97 - 6) = 6.03\text{dBm}$.

Spectrum Plot of Worst Value

802.11b / Chain 0 : CH6

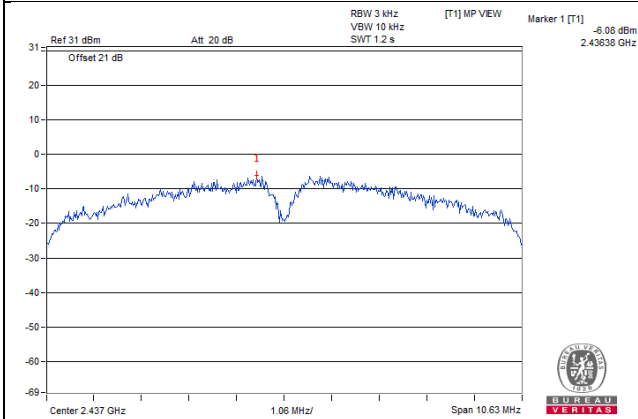

802.11g / Chain 0 : CH1

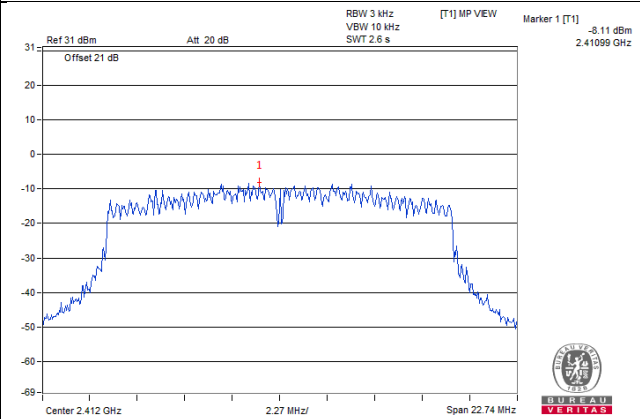

802.11n (HT20) / Chain 0 : CH1

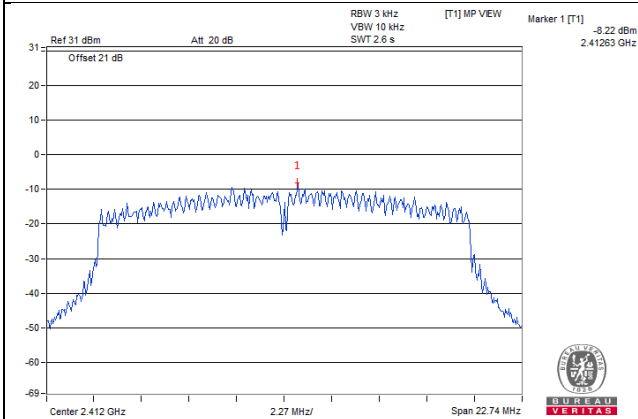

802.11n (HT40) / Chain 0 : CH6

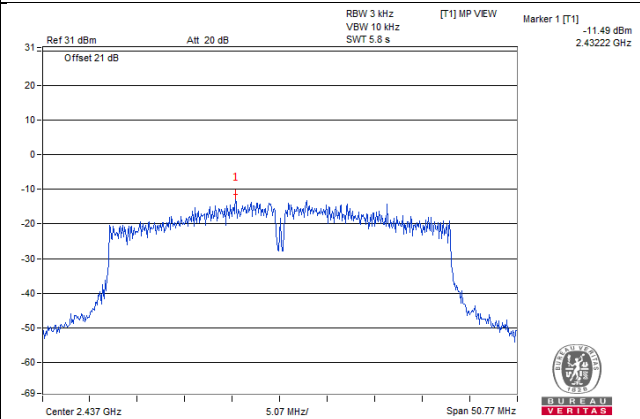

4.7 Conducted Out of Band Emission Measurement

4.7.1 Limits of Conducted Out of Band Emission Measurement

Below -20dB of the highest emission level of operating band (in 100kHz Resolution Bandwidth).

4.7.2 Test Setup

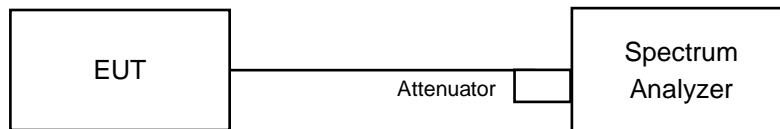

4.7.3 Test Instruments

Refer to section 4.1.2 to get information of above instrument.

4.7.4 Test Procedure

MEASUREMENT PROCEDURE REF

1. Set the RBW = 100 kHz.
2. Set the VBW \geq 300 kHz.
3. Detector = peak.
4. Sweep time = auto couple.
5. Trace mode = max hold.
6. Allow trace to fully stabilize.
7. Use the peak marker function to determine the maximum power level in any 100 kHz band segment within the fundamental EBW.

MEASUREMENT PROCEDURE OOBE

1. Set RBW = 100 kHz.
2. Set VBW \geq 300 kHz.
3. Detector = peak.
4. Sweep = auto couple.
5. Trace Mode = max hold.
6. Allow trace to fully stabilize.
7. Use the peak marker function to determine the maximum amplitude level.

4.7.5 Deviation from Test Standard

No deviation.

4.7.6 EUT Operating Condition

Same as Item 4.3.6

4.7.7 Test Results

The spectrum plots are attached on the following pages. D1 line indicates the highest level, and D2 line indicates the 20dB offset below D1. It shows compliance with the requirement.

802.11b

Chain 0

CH 1

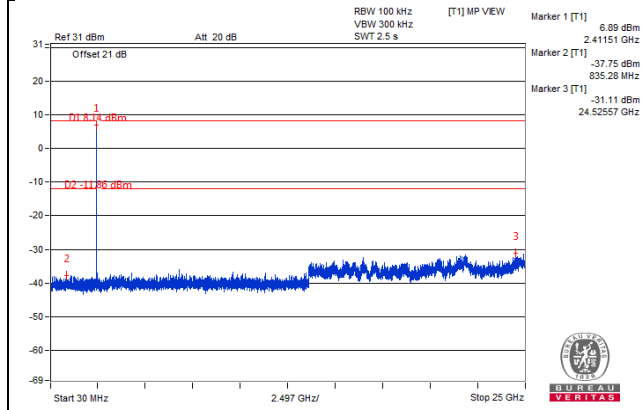
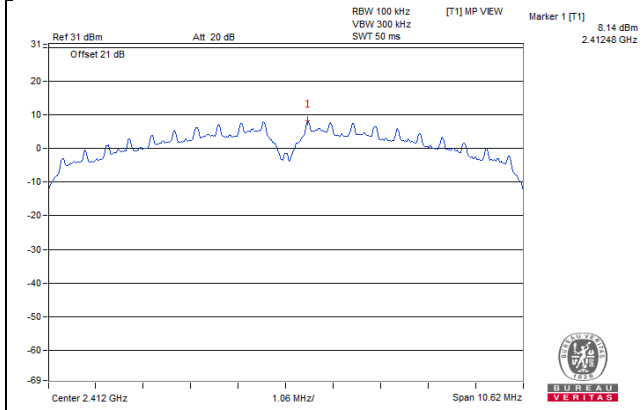

CH 6

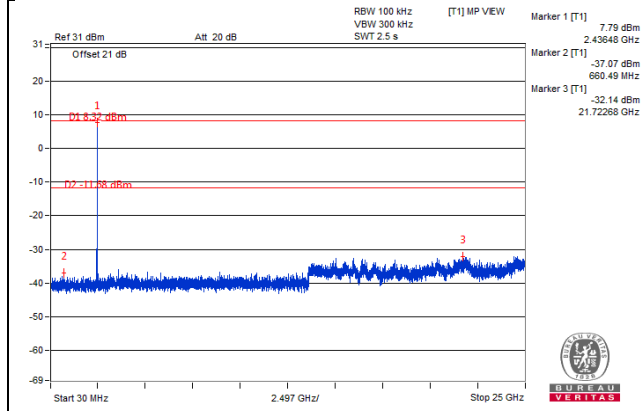
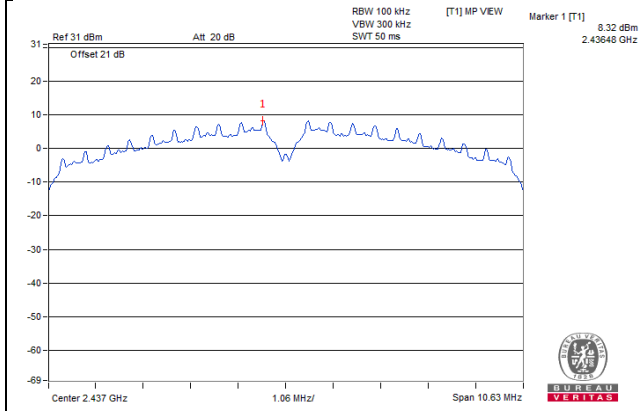

CH 11

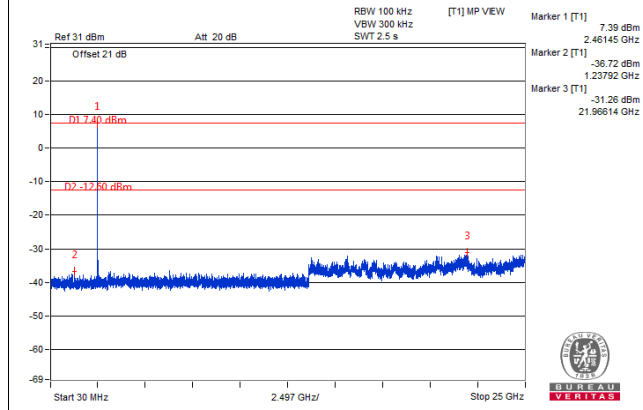
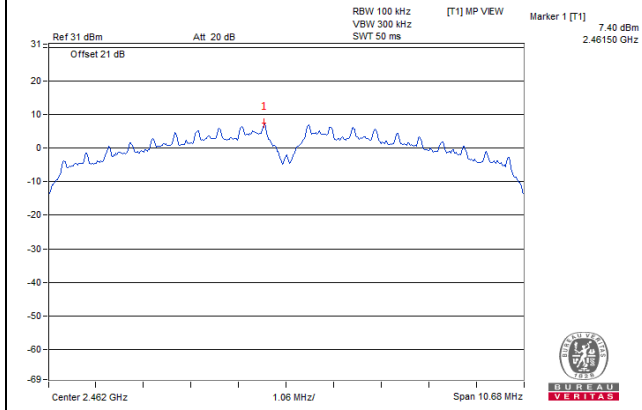

CH 1 Band edge

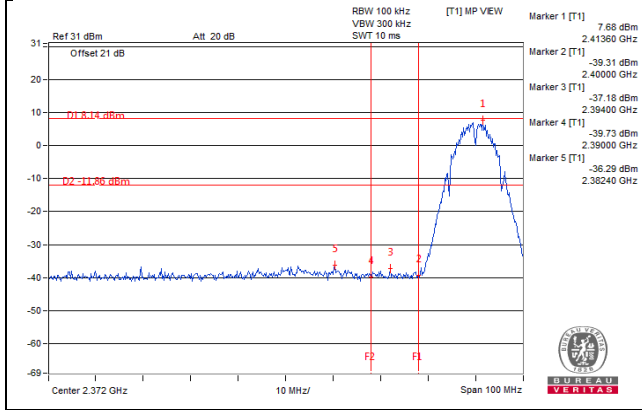

CH 11 Band edge

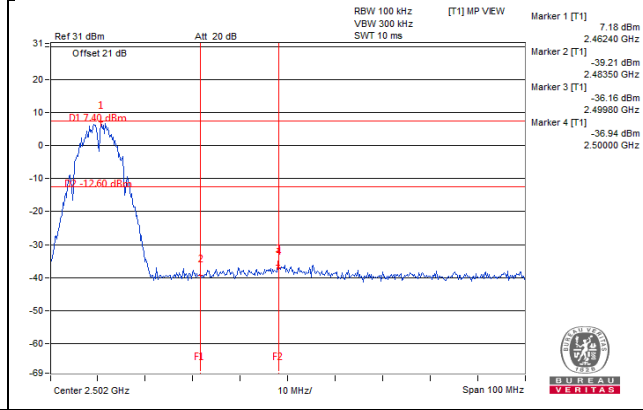

Chain 1

CH 1

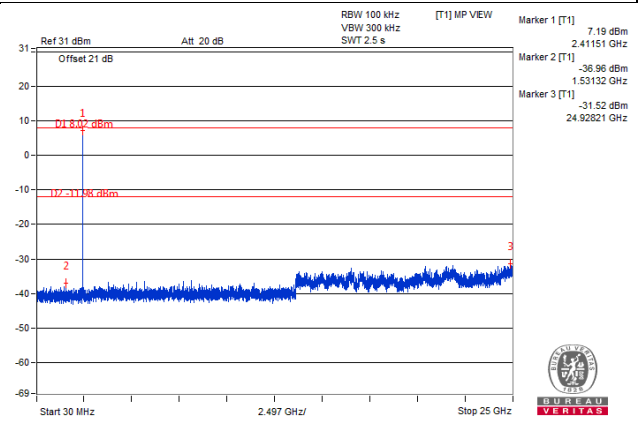
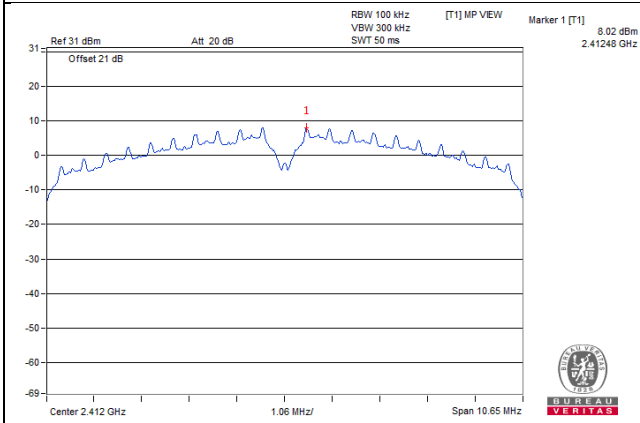

CH 6

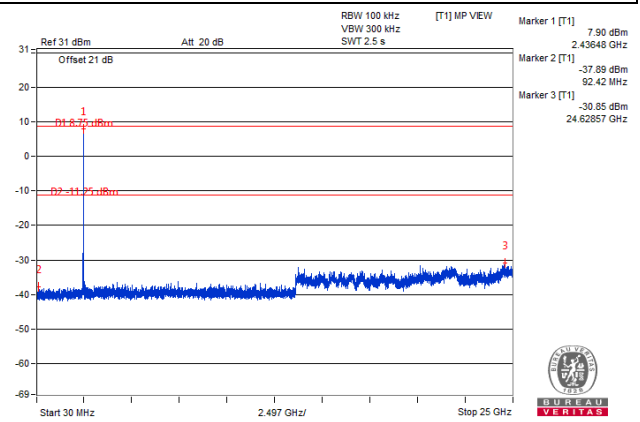
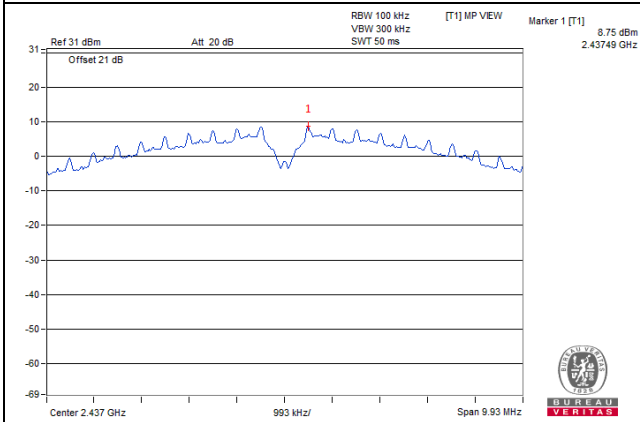

CH 11

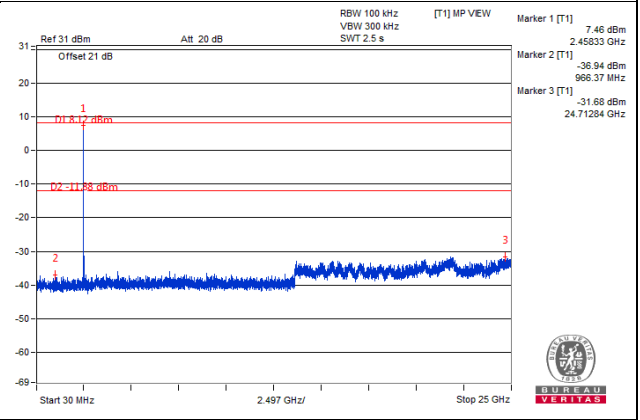
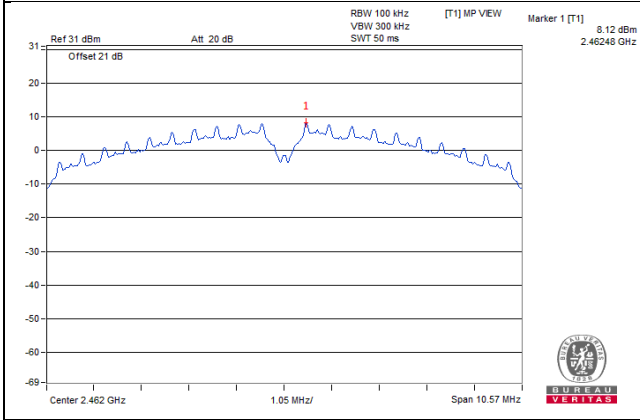

CH 1 Band edge

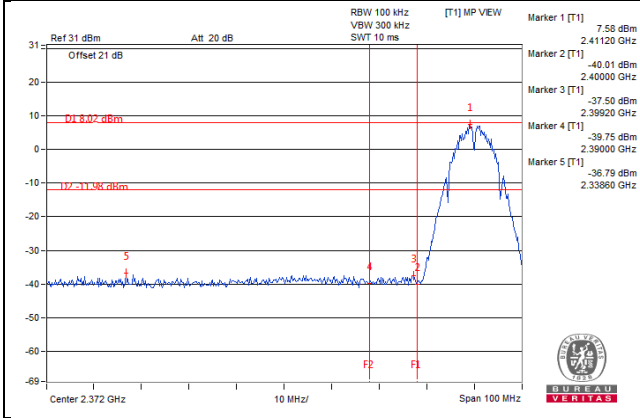

CH 11 Band edge

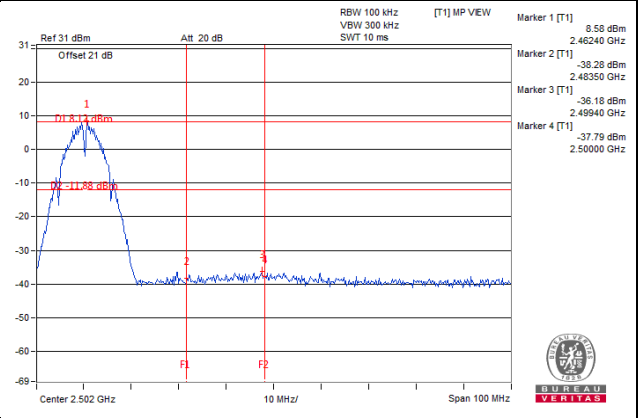

802.11g
Chain 0

CH 1

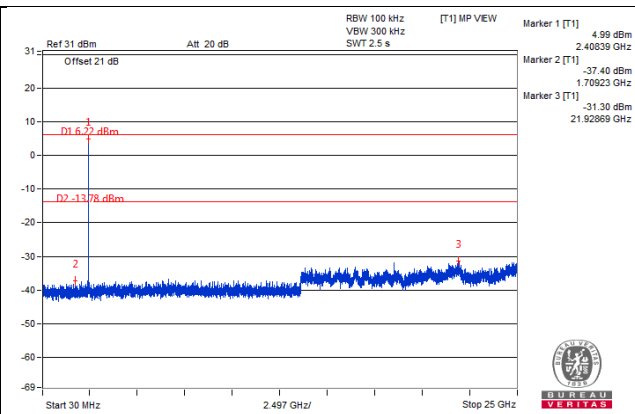
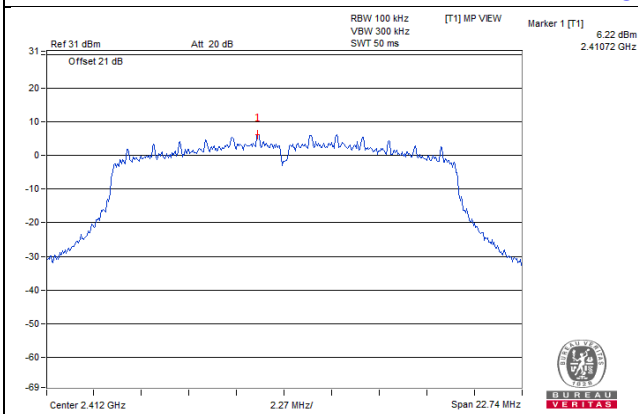

CH 6

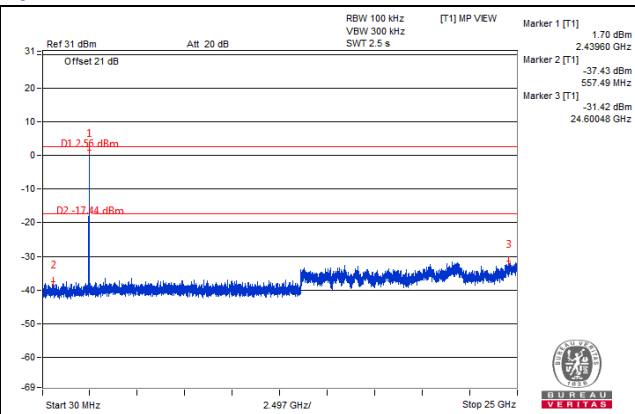
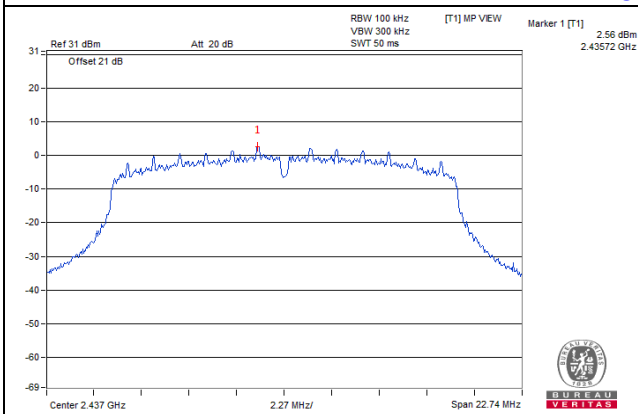

CH 11

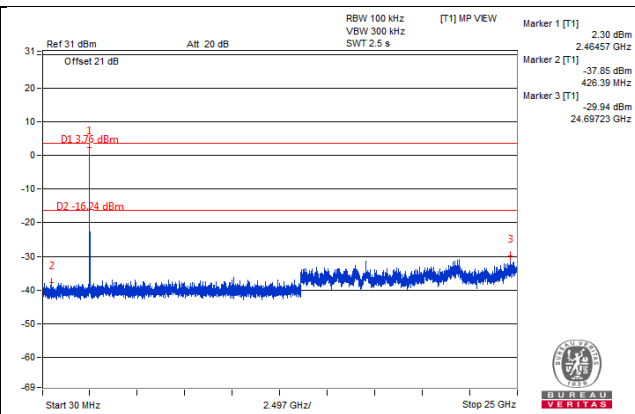
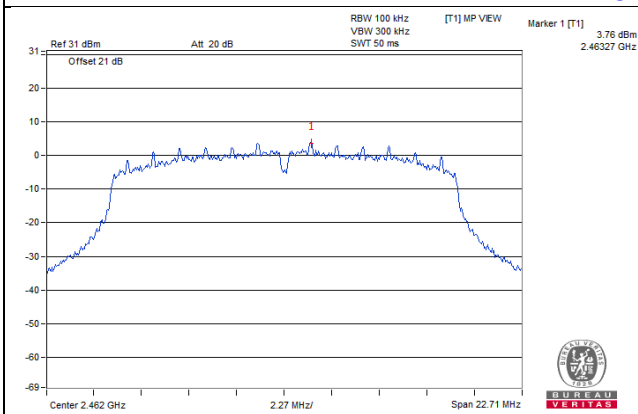

CH 1 Band edge

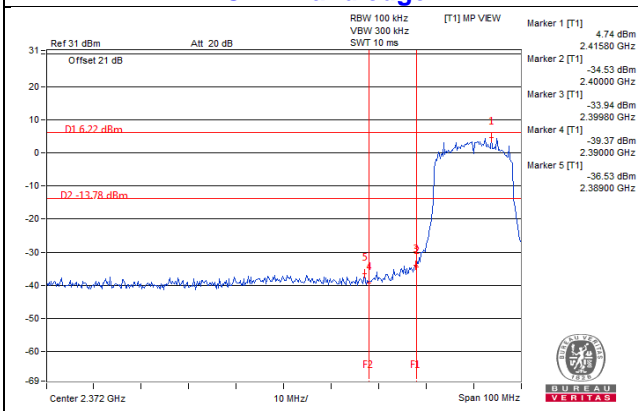

CH 11 Band edge

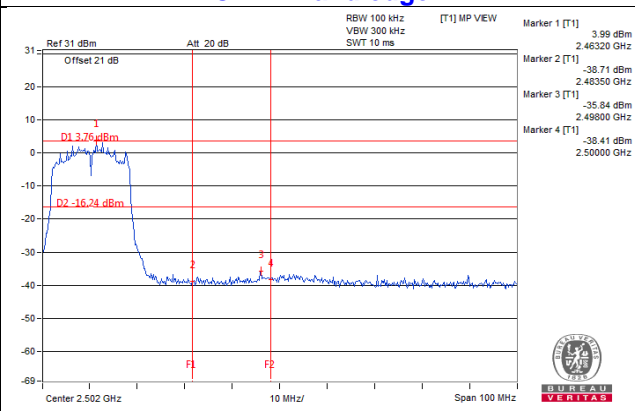

Chain 1

CH 1

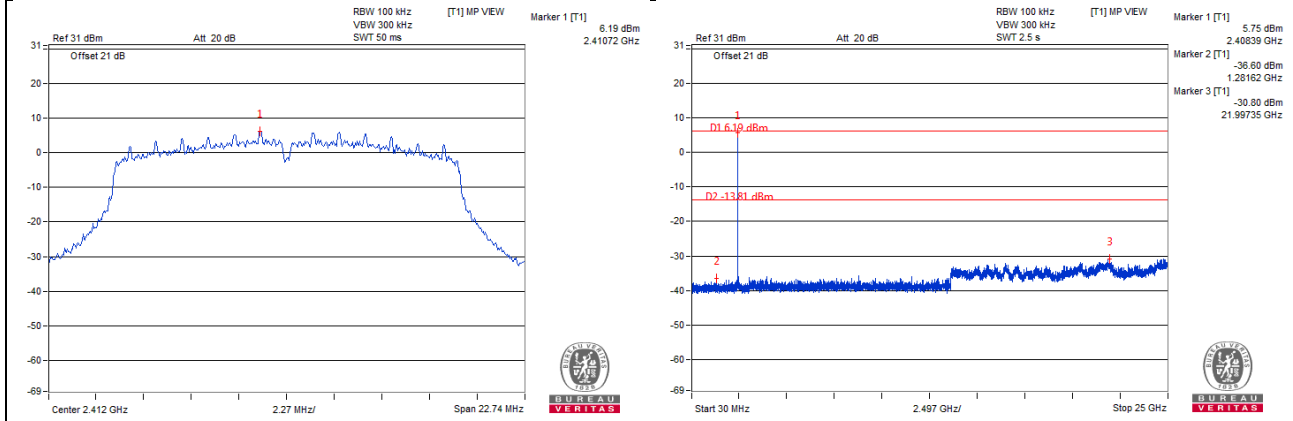

CH 6

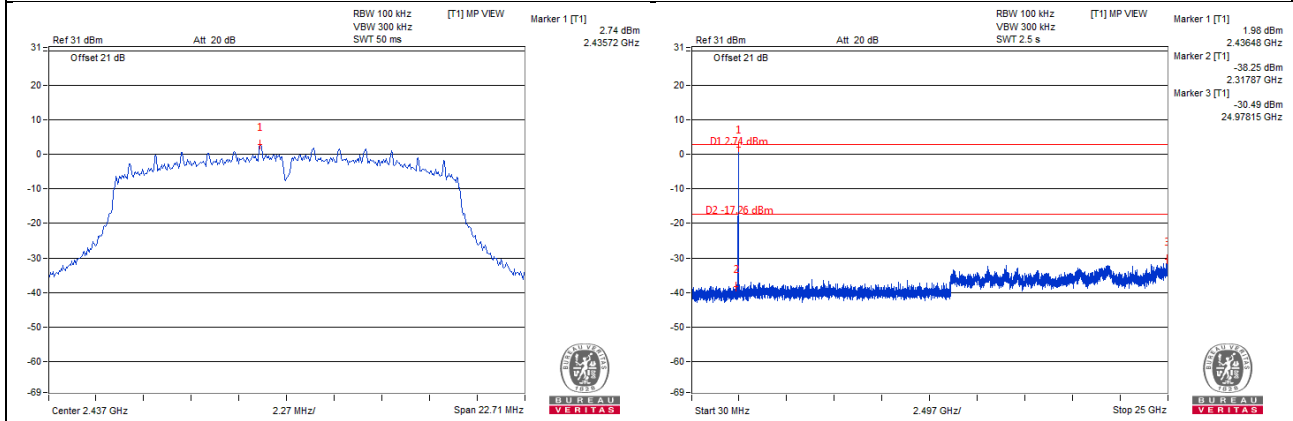

CH 11

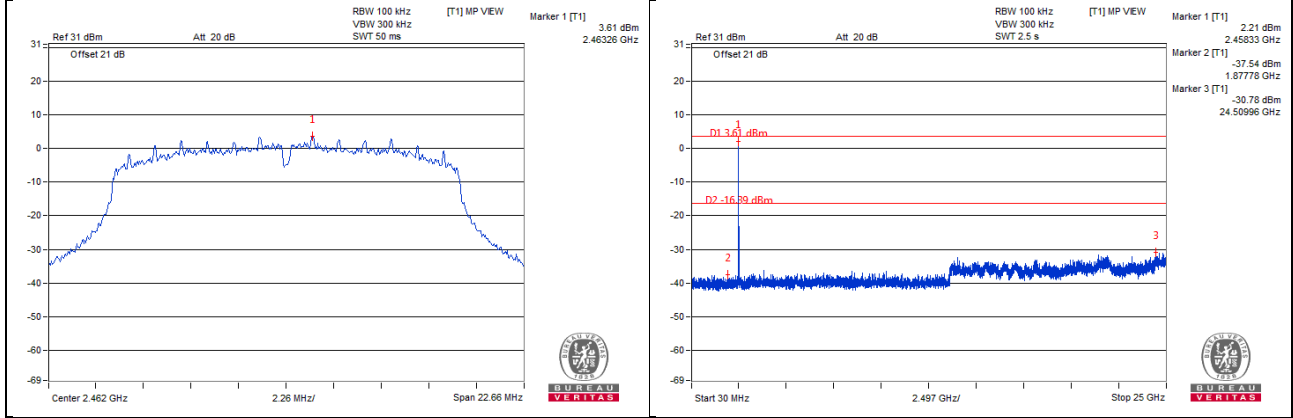

CH 1 Band edge

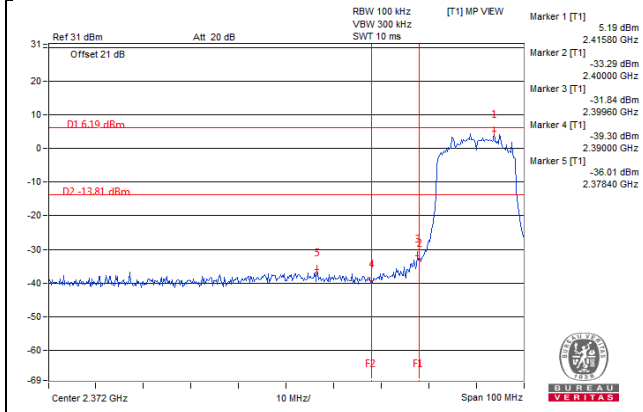

CH 11 Band edge

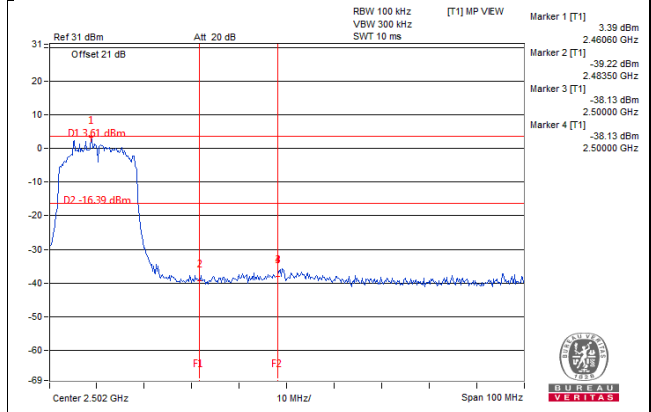

802.11n (HT20)
Chain 0

CH 1

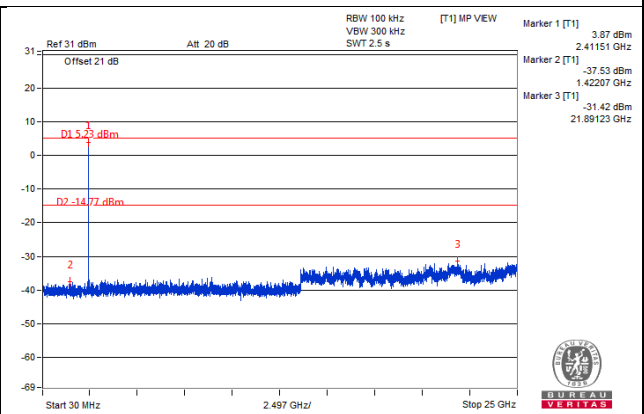
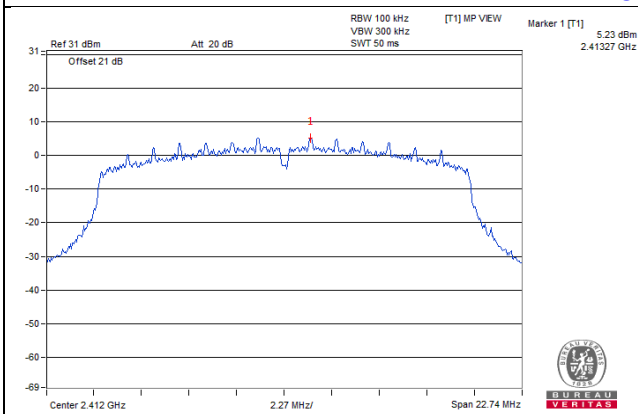

CH 6

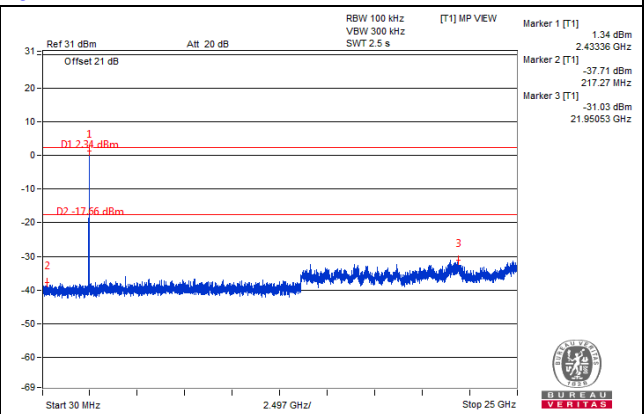
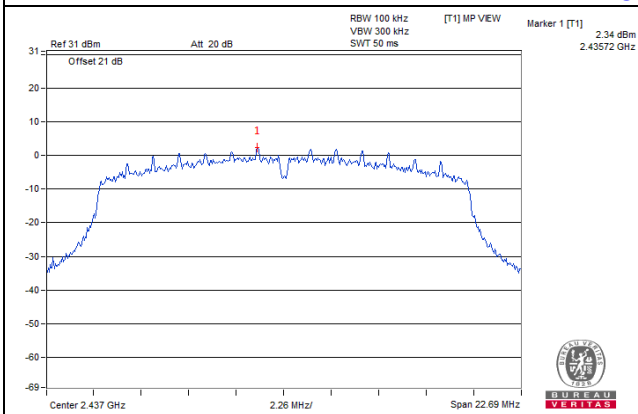

CH 11

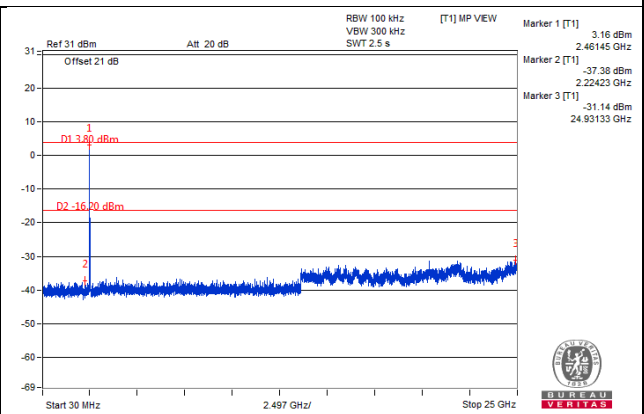
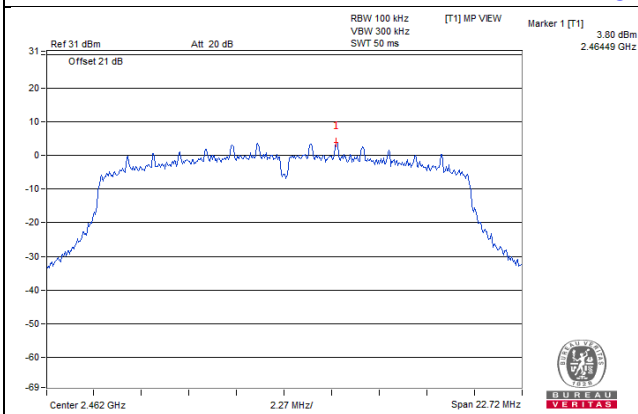

CH 1 Band edge

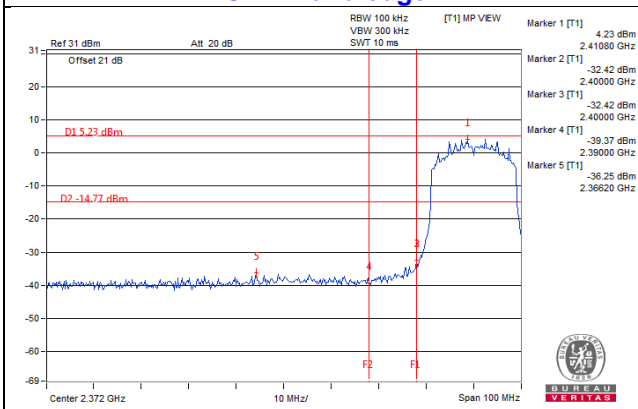

CH 11 Band edge

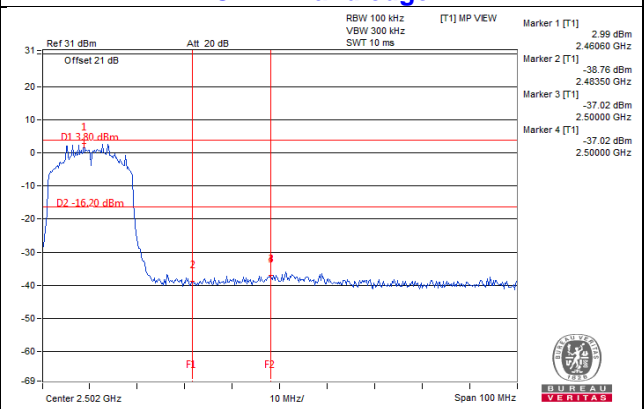

Chain 1

CH 1

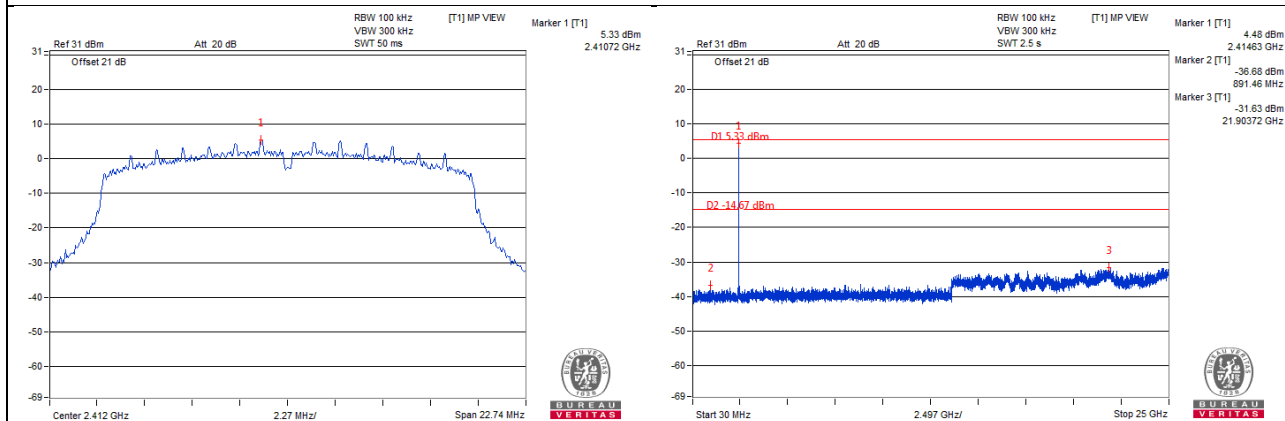

CH 6

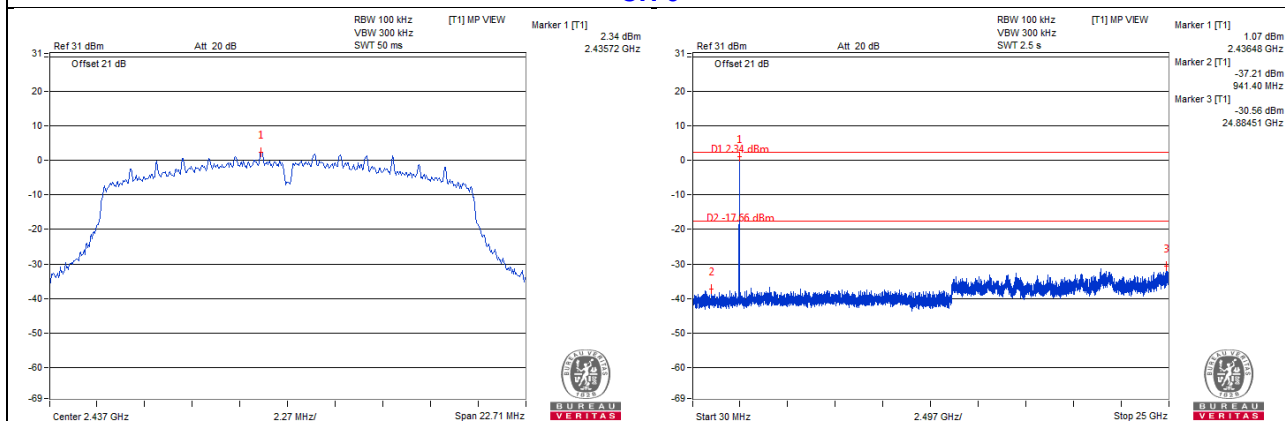

CH 11

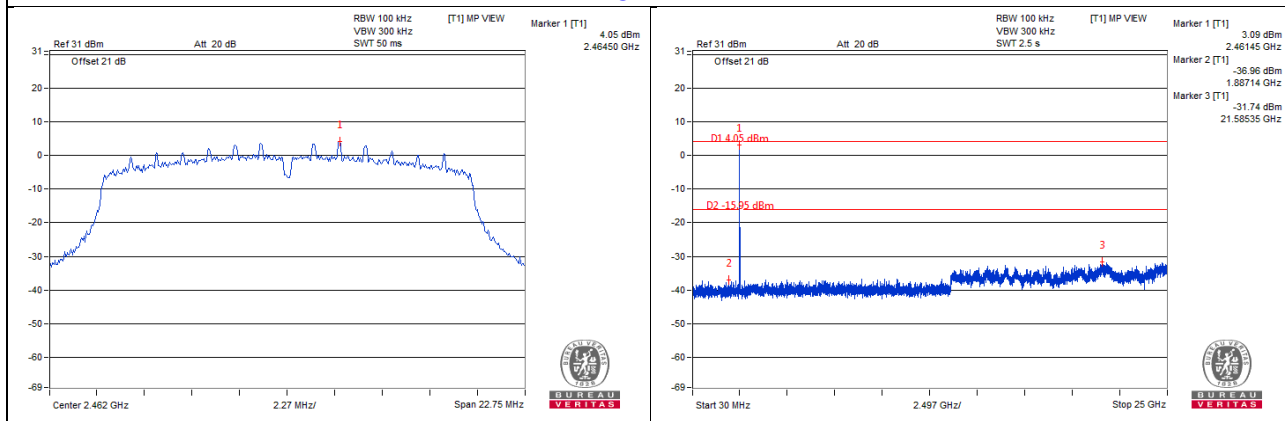

CH 1 Band edge

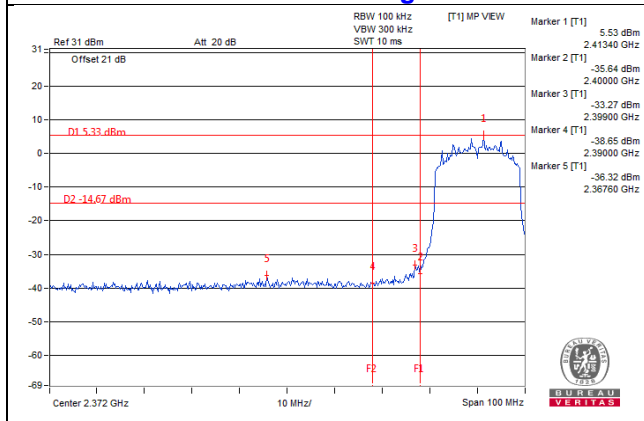

CH 11 Band edge

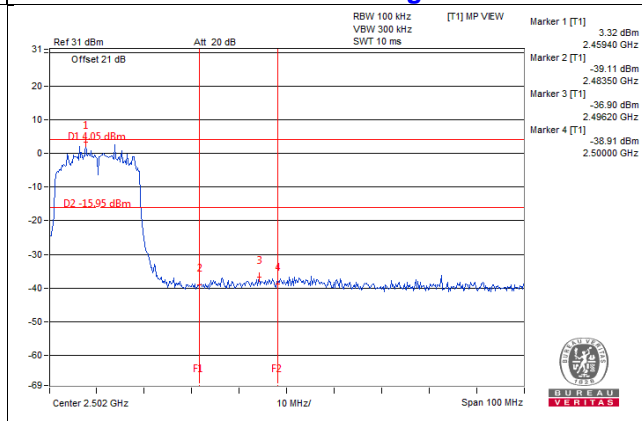

802.11n (HT40)
Chain 0

CH 3

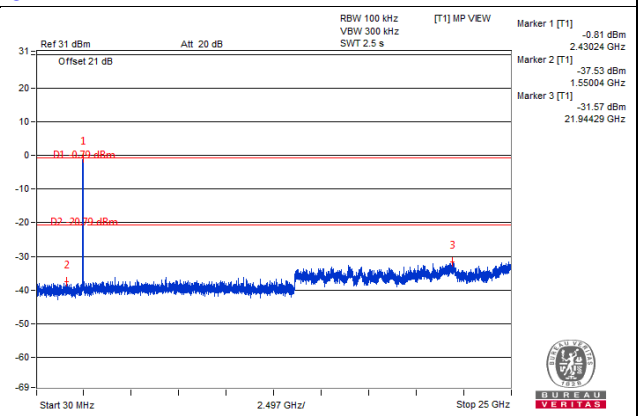
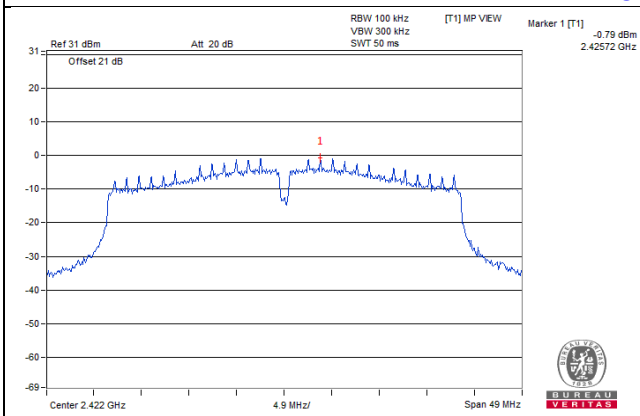

CH 6

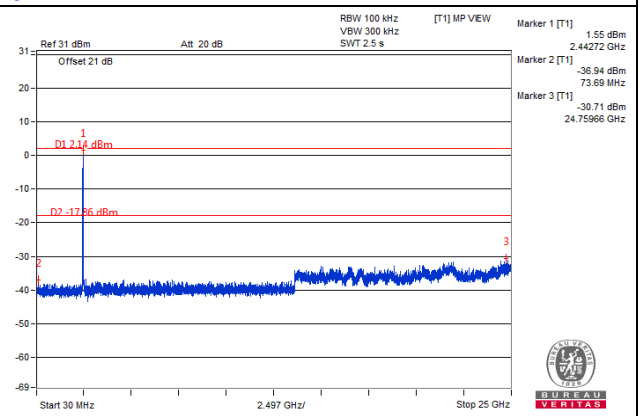
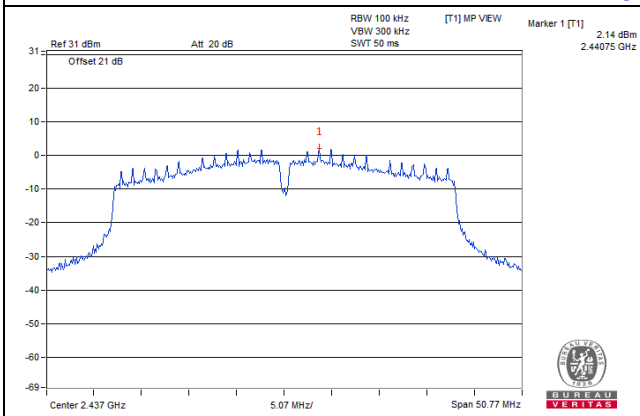

CH 9

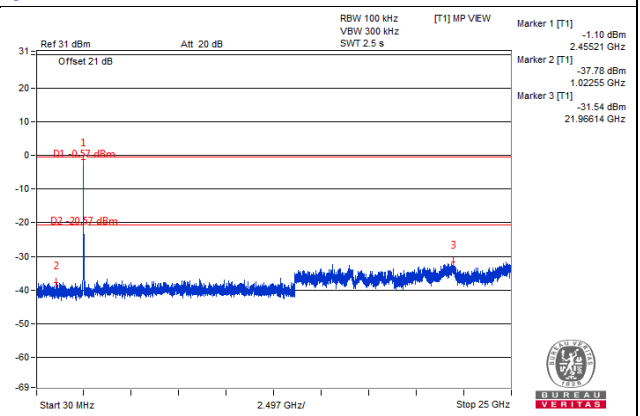
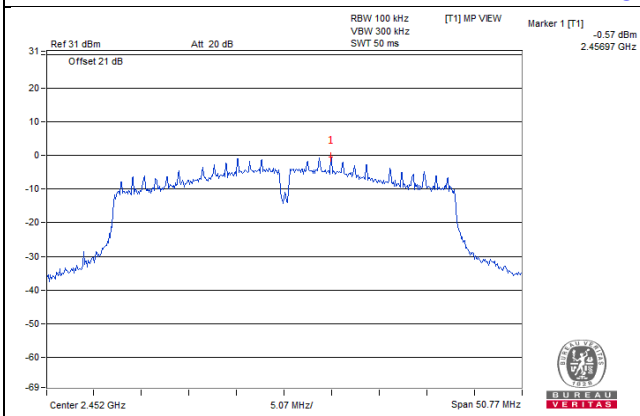

CH 3 Band edge

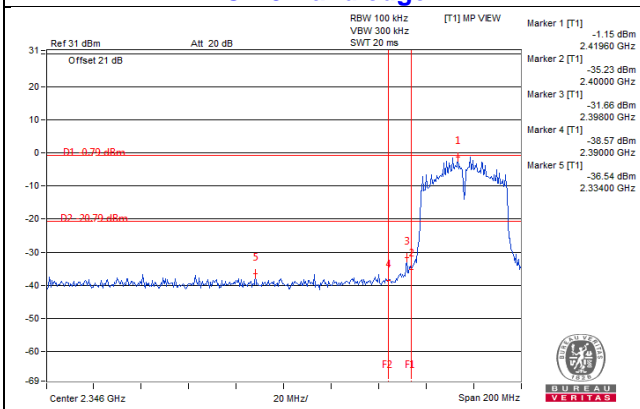

CH 9 Band edge

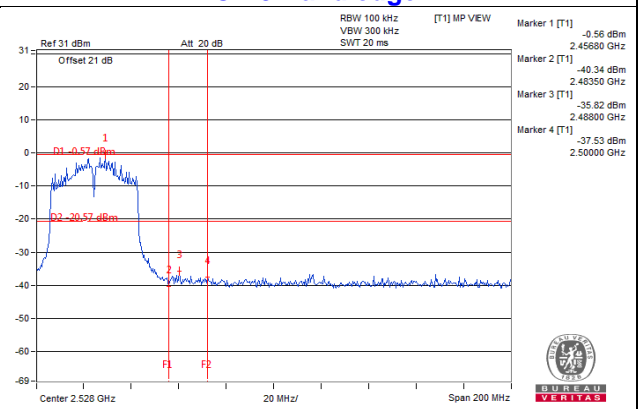

Chain 1

CH 3

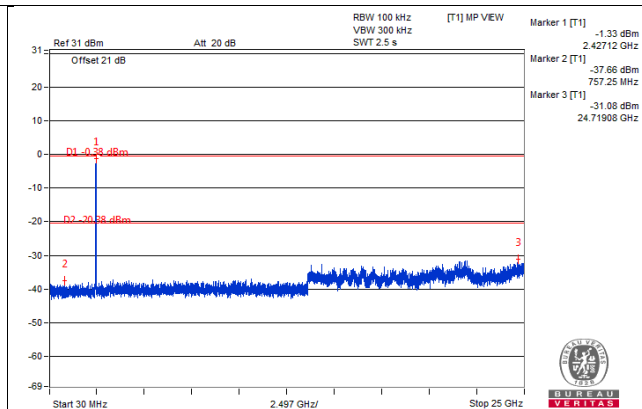
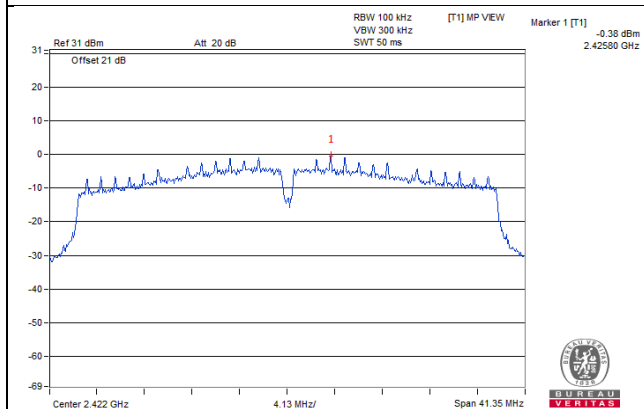

CH 6

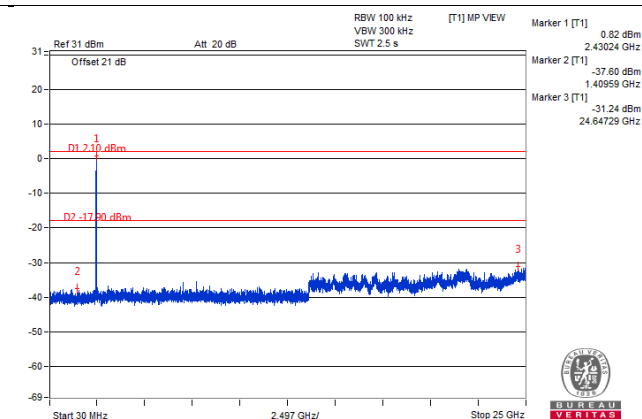
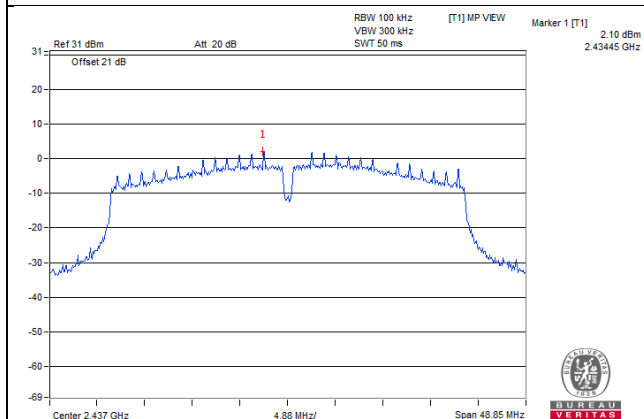

CH 9

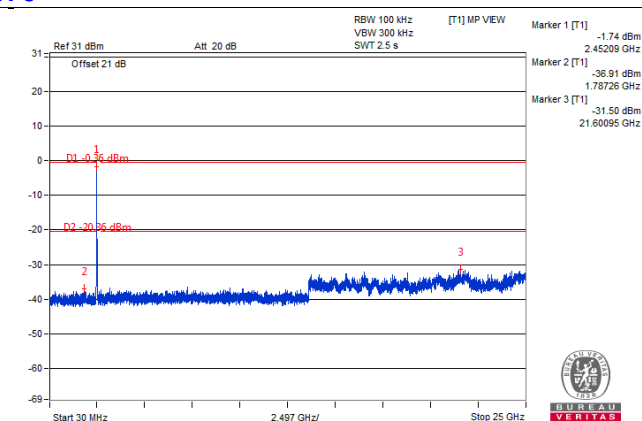
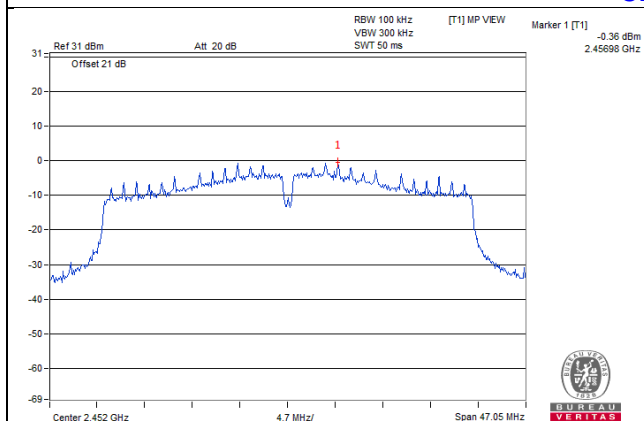

CH 3 Band edge

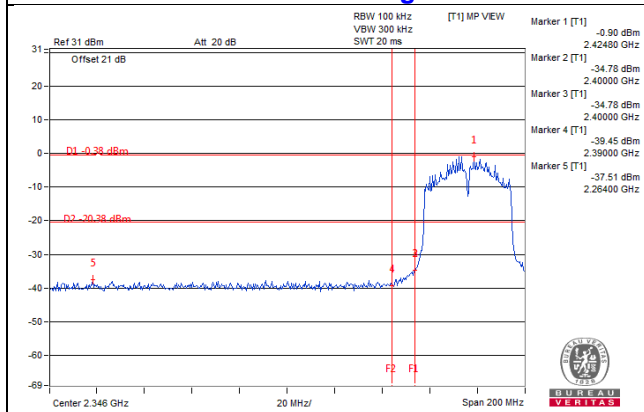

CH 9 Band edge

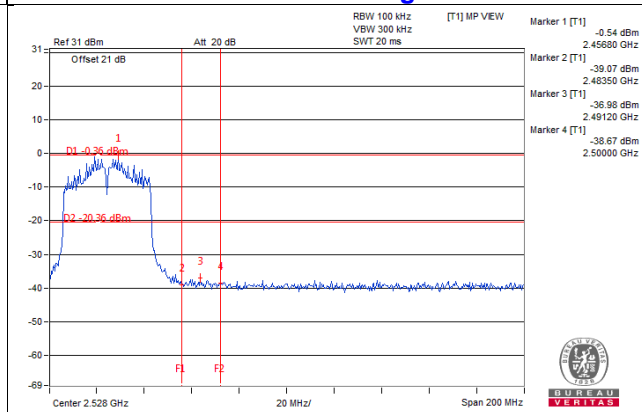

5 Pictures of Test Arrangements

Please refer to the attached file (Test Setup Photo).

Appendix – Information on the Testing Laboratories

We, Bureau Veritas Consumer Products Services (H.K.) Ltd., Taoyuan Branch, were founded in 1988 to provide our best service in EMC, Radio, Telecom and Safety consultation. Our laboratories are FCC recognized accredited test firms and accredited according to ISO/IEC 17025.

If you have any comments, please feel free to contact us at the following:

Linkou EMC/RF Lab

Tel: 886-2-26052180

Fax: 886-2-26051924

Hsin Chu EMC/RF/Telecom Lab

Tel: 886-3-6668565

Fax: 886-3-6668323

Hwa Ya EMC/RF/Safety Lab

Tel: 886-3-3183232

Fax: 886-3-3270892

Email: service.adt@tw.bureauveritas.com

Web Site: www.bureauveritas-adt.com

The address and road map of all our labs can be found in our web site also.

--- END ---