

FCC Test Report

Report No.: RF140423C02B-1

FCC ID: YZKECW5210L

Test Model: ECW5210-L

Received Date: Oct. 26, 2017

Test Date: Nov. 11, 2017

Issued Date: Nov. 16, 2017

Applicant: Edgecore Networks Corporation

Address: No. 1 Creation Rd. III, Hsinchu Science Park, Hsinchu 30077, Taiwan

Issued By: Bureau Veritas Consumer Products Services (H.K.) Ltd., Taoyuan Branch

Lab Address: No. 47-2, 14th Ling, Chia Pau Vil., Lin Kou Dist., New Taipei City, Taiwan
(R.O.C)

Test Location: No. 19, Hwa Ya 2nd Rd, Wen Hwa Tsuen, Kwei Shan Hsiang, Taoyuan
Hsien 333, Taiwan, R.O.C.

**FCC Registration /
Designation Number:** 788550 / TW0003



This report is for your exclusive use. Any copying or replication of this report to or for any other person or entity, or use of our name or trademark, is permitted only with our prior written permission. This report sets forth our findings solely with respect to the test samples identified herein. The results set forth in this report are not indicative or representative of the quality or characteristics of the lot from which a test sample was taken or any similar or identical product unless specifically and expressly noted. Our report includes all of the tests requested by you and the results thereof based upon the information that you provided to us. You have 60 days from date of issuance of this report to notify us of any material error or omission caused by our negligence, provided, however, that such notice shall be in writing and shall specifically address the issue you wish to raise. A failure to raise such issue within the prescribed time shall constitute your unqualified acceptance of the completeness of this report, the tests conducted and the correctness of the report contents. Unless specific mention, the uncertainty of measurement has been explicitly taken into account to declare the compliance or non-compliance to the specification. The report must not be used by the client to claim product certification, approval, or endorsement by TAF or any government agencies.

Table of Contents

Release Control Record	4
1 Certificate of Conformity	5
2 Summary of Test Results	6
2.1 Measurement Uncertainty	6
2.2 Modification Record	6
3 General Information	7
3.1 General Description of EUT	7
3.2 Description of Test Modes.....	9
3.2.1 Test Mode Applicability and Tested Channel Detail	10
3.3 Duty Cycle of Test Signal	12
3.4 Description of Support Units	14
3.4.1 Configuration of System under Test	14
3.5 General Description of Applied Standards.....	15
4 Test Types and Results	16
4.1 Radiated Emission and Bandedge Measurement	16
4.1.1 Limits of Radiated Emission and Bandedge Measurement	16
4.1.2 Limits of Unwanted Emission Out of the Restricted Bands	17
4.1.3 Test Instruments	18
4.1.4 Test Procedures.....	20
4.1.5 Deviation from Test Standard	20
4.1.6 Test Set Up	21
4.1.7 EUT Operating Conditions.....	22
4.1.8 Test Results	23
4.2 Conducted Emission Measurement.....	43
4.2.1 Limits of Conducted Emission Measurement	43
4.2.2 Test Instruments	43
4.2.3 Test Procedures.....	44
4.2.4 Deviation from Test Standard	44
4.2.5 Test Setup.....	44
4.2.6 EUT Operating Conditions.....	44
4.2.7 Test Results	45
4.3 Transmit Power Measurement.....	47
4.3.1 Limits of Transmit Power Measurement	47
4.3.2 Test Setup.....	47
4.3.3 Test Instruments	48
4.3.4 Test Procedure	48
4.3.5 Deviation from Test Standard	48
4.3.6 EUT Operating Conditions.....	48
4.3.7 Test Result	49
4.4 Occupied Bandwidth Measurement.....	52
4.4.1 Test Setup.....	52
4.4.2 Test Instruments	52
4.4.3 Test Procedure	52
4.4.4 Test Results	53
4.5 Peak Power Spectral Density Measurement	55
4.5.1 Limits of Peak Power Spectral Density Measurement	55
4.5.2 Test Setup.....	55
4.5.3 Test Instruments	55
4.5.4 Test Procedures.....	55
4.5.5 Deviation from Test Standard	56
4.5.6 EUT Operating Conditions.....	56
4.5.7 Test Results	57
4.6 Frequency Stability	62

4.6.1	Limit of Frequency Stability Measurement	62
4.6.2	Test Setup.....	62
4.6.3	Test Instruments	62
4.6.4	Test Procedure	62
4.6.5	Deviation from Test Standard	62
4.6.6	EUT Operating Condition	62
4.6.7	Test Results	63
4.7	6 dB Bandwidth Measurement.....	64
4.7.1	Limits of 6 dB Bandwidth Measurement.....	64
4.7.2	Test Setup.....	64
4.7.3	Test Instruments	64
4.7.4	Test Procedure	64
4.7.5	Deviation from Test Standard	64
4.7.6	EUT Operating Condition	64
4.7.7	Test Results	65
5	Pictures of Test Arrangements.....	67
	Annex A- Radiated Out of Band Emisison (OOBE) Measurement (For U-NII-3 band)	68
	Appendix – Information on the Testing Laboratories	71

Release Control Record

Issue No.	Description	Date Issued
RF140423C02B-1	Original Release	Nov. 16, 2017

1 Certificate of Conformity

Product: Enterprise Access Point

Brand: Edgecore

Test Model: ECW5210-L

Sample Status: Production Unit

Applicant: Edgecore Networks Corporation

Test Date: Nov. 11, 2017

Standards: 47 CFR FCC Part 15, Subpart E (Section 15.407)
ANSI C63.10:2013

The above equipment has been tested by **Bureau Veritas Consumer Products Services (H.K.) Ltd., Taoyuan Branch**, and found compliance with the requirement of the above standards. The test record, data evaluation & Equipment Under Test (EUT) configurations represented herein are true and accurate accounts of the measurements of the sample's RF characteristics under the conditions specified in this report.

Prepared by :

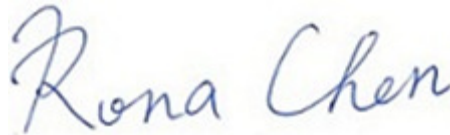

Date: Nov. 16, 2017

Rona Chen / Specialist

Approved by :

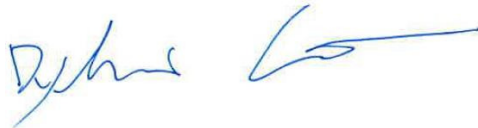

Date: Nov. 16, 2017

Dylan Chiou / Project Engineer

2 Summary of Test Results

47 CFR FCC Part 15, Subpart E (Section 15.407)			
FCC Clause	Test Item	Result	Remarks
15.407(b)(6)	AC Power Conducted Emissions	Pass	Meet the requirement of limit. Minimum passing margin is -7.35 dB at 0.15781 MHz.
15.407(b) (1/2/3/4(i/ii)/6)	Radiated Emissions & Band Edge Measurement	Pass	Meet the requirement of limit. Minimum passing margin is -1.18 dB at 5150 MHz.
15.407(a)(1/2/3)	Max Average Transmit Power	Pass	Meet the requirement of limit.
---	Occupied Bandwidth Measurement	-	Reference only
15.407(a)(1/2/3)	Peak Power Spectral Density	Pass	Meet the requirement of limit.
15.407(e)	6 dB Bandwidth	Pass	Meet the requirement of limit. (U-NII-3 Band only)
15.407(g)	Frequency Stability	Pass	Meet the requirement of limit.
15.203	Antenna Requirement	Pass	No antenna connector is used.

*For U-NII-3 band compliance with rule part 15.407(b)(4)(i), the OOB test plots were recorded in Annex A.

2.1 Measurement Uncertainty

Where relevant, the following measurement uncertainty levels have been estimated for tests performed on the EUT as specified in CISPR 16-4-2:

Measurement	Frequency	Expanded Uncertainty (k=2) (\pm)
Conducted Emissions at mains ports	150 kHz ~ 30 MHz	2.44 dB
Radiated Emissions up to 1 GHz	30 MHz ~ 200 MHz	2.93 dB
	200 MHz ~ 1000 MHz	2.95 dB
Radiated Emissions above 1 GHz	1 GHz ~ 18 GHz	2.26 dB
	18 GHz ~ 40 GHz	1.94 dB

2.2 Modification Record

There were no modifications required for compliance.

3 General Information

3.1 General Description of EUT

Product	Enterprise Access Point
Brand	Edgecore
Test Model	ECW5210-L
Status of EUT	Production Unit
Power Supply Rating	12Vdc (Adapter)
Modulation Type	256QAM, 64QAM, 16QAM, QPSK, BPSK
Modulation Technology	OFDM
Transfer Rate	802.11a: 54.0/ 48.0/ 36.0/ 24.0/ 18.0/ 12.0/ 9.0/ 6.0 Mbps 802.11n: up to MCS7 802.11ac: up to V9
Operating Frequency	5180 ~ 5240 MHz, 5745 ~ 5825 MHz
Number of Channel	5180 ~ 5240 MHz: 4 for 802.11a, 802.11n (HT20) 2 for 802.11n (HT40) 1 for 802.11ac (VHT80) 5745 ~ 5825 MHz: 5 for 802.11a, 802.11n (HT20) 2 for 802.11n (HT40) 1 for 802.11ac (VHT80)
Output Power	39.628 mW for 5180 ~ 5240 MHz 97.674 mW for 5745 ~ 5825 MHz
Antenna Type	Refer to Note as below
Antenna Connector	N/A
Accessory Device	Refer to Note as below
Data Cable Supplied	Refer to Note as below

Note:

- The antenna information is listed as below.

Antenna Type	Antenna Model	Band	Frequency Band	Tx Antenna	Antenna Gain
PCB	AP331AI	sercomm	5180 ~ 5240	1	4.67
				2	4.1
				3	3.94
			5745 ~ 5825	1	4.42
				2	4.5
				3	3.98

- The EUT contains following accessory devices.

Item	Brand	Model	Specification
Adapter	Asian	WA-30B12	I/P: 100-240Vac, 50-60Hz, 0.8A O/P: 12Vdc, 2.5A AC power code 1.5m

3. The EUT incorporates a MIMO function. Physically, the EUT provides 3 completed transmitters and 3 receivers.

Modulation Mode	Tx Function
802.11a	1TX
802.11n (HT20)	3TX
802.11n (HT40)	3TX
802.11ac (VHT80)	3TX

4. The above EUT information is declared by manufacturer and for more detailed features description, please refer to the manufacturer's specifications or user's manual.

3.2 Description of Test Modes

For 5180 ~ 5240 MHz

4 channels are provided for 802.11a, 802.11n (HT20):

Channel	Frequency (MHz)	Channel	Frequency (MHz)
36	5180	44	5220
40	5200	48	5240

2 channels are provided for 802.11n (HT40):

Channel	Frequency (MHz)	Channel	Frequency (MHz)
38	5190	46	5230

1 channel is provided for 802.11ac (VHT80):

Channel	Frequency (MHz)
42	5210

For 5745 ~ 5825 MHz:

5 channels are provided for 802.11a, 802.11n (HT20):

Channel	Frequency (MHz)	Channel	Frequency (MHz)
149	5745	161	5805
153	5765	165	5825
157	5785		

2 channels are provided for 802.11n (HT40):

Channel	Frequency (MHz)	Channel	Frequency (MHz)
151	5755	159	5795

1 channel is provided for 802.11ac (VHT80):

Channel	Frequency (MHz)
155	5775

3.2.1 Test Mode Applicability and Tested Channel Detail

EUT Configure Mode	Applicable To				Description
	RE \geq 1G	RE $<$ 1G	PLC	APCM	
-	√	√	√	√	-

Where **RE \geq 1G**: Radiated Emission above 1 GHz **RE $<$ 1G**: Radiated Emission below 1 GHz
PLC: Power Line Conducted Emission **APCM**: Antenna Port Conducted Measurement

Note: The EUT had been pre-tested on the positioned of each 3 axis. The worst case was found when positioned on **Z-plane** for U-NII-1 and **X-plane** for U-NII-3.

Radiated Emission Test (Above 1 GHz):

- Pre-Scan has been conducted to determine the worst-case mode from all possible combinations between available modulations, data rates and antenna ports (if EUT with antenna diversity architecture).
- Following channel(s) was (were) selected for the final test as listed below.

EUT Configure Mode	Frequency Band (MHz)	Mode	Available Channel	Tested Channel	Modulation Technology	Modulation Type	Data Rate (Mbps)
-	5180-5240	802.11a	36 to 48	36, 44, 48	OFDM	BPSK	6.0
-		802.11n (HT20)	36 to 48	36, 44, 48	OFDM	BPSK	MCS0
-		802.11n (HT40)	38 to 46	38, 46	OFDM	BPSK	MCS0
-		802.11ac (VHT80)	42	42	OFDM	BPSK	MCS0
-	5745-5825	802.11a	149 to 165	149, 157, 165	OFDM	BPSK	6.0
-		802.11n (HT20)	149 to 165	149, 157, 165	OFDM	BPSK	MCS0
-		802.11n (HT40)	151 to 159	151, 159	OFDM	BPSK	MCS0
-		802.11ac (VHT80)	155	155	OFDM	BPSK	MCS0

Radiated Emission Test (Below 1 GHz):

- Pre-Scan has been conducted to determine the worst-case mode from all possible combinations between available modulations, data rates and antenna ports (if EUT with antenna diversity architecture).
- Following channel(s) was (were) selected for the final test as listed below.

EUT Configure Mode	Frequency Band (MHz)	Mode	Available Channel	Tested Channel	Modulation Technology	Modulation Type	Data Rate (Mbps)
-	5180-5240	802.11ac (VHT80)	42	42	OFDM	BPSK	MCS0
-	5745-5825	802.11a	149 to 165	149	OFDM	BPSK	6.0

Power Line Conducted Emission Test:

- Pre-Scan has been conducted to determine the worst-case mode from all possible combinations between available modulations, data rates and antenna ports (if EUT with antenna diversity architecture).
- Following channel(s) was (were) selected for the final test as listed below.

EUT Configure Mode	Frequency Band (MHz)	Mode	Available Channel	Tested Channel	Modulation Technology	Modulation Type	Data Rate (Mbps)
-	5180-5240	802.11ac (VHT80)	42	42	OFDM	BPSK	MCS0

- This item includes all test value of each mode, but only includes spectrum plot of worst value of each mode.
- Pre-Scan has been conducted to determine the worst-case mode from all possible combinations between available modulations, data rates and antenna ports (if EUT with antenna diversity architecture).
- Following channel(s) was (were) selected for the final test as listed below.

EUT Configure Mode	Frequency Band (MHz)	Mode	Available Channel	Tested Channel	Modulation Technology	Modulation Type	Data Rate (Mbps)
-	5180-5240	802.11a	36 to 48	36, 44, 48	OFDM	BPSK	6.0
-		802.11n (HT20)	36 to 48	36, 44, 48	OFDM	BPSK	MCS0
-		802.11n (HT40)	38 to 46	38, 46	OFDM	BPSK	MCS0
-		802.11ac (VHT80)	42	42	OFDM	BPSK	MCS0
-	5745-5825	802.11a	149 to 165	149, 157, 165	OFDM	BPSK	6.0
-		802.11n (HT20)	149 to 165	149, 157, 165	OFDM	BPSK	MCS0
-		802.11n (HT40)	151 to 159	151, 159	OFDM	BPSK	MCS0
-		802.11ac (VHT80)	155	155	OFDM	BPSK	MCS0

Test Condition:

Applicable To	Environmental Conditions	Input Power	Tested by
RE \geq 1G	25 deg. C, 65 % RH	120 Vac, 60 Hz	Greg Lin
RE $<$ 1G	25 deg. C, 65 % RH	120 Vac, 60 Hz	Greg Lin
PLC	25 deg. C, 65 % RH	120 Vac, 60 Hz	Anson Lin
APCM	25 deg. C, 65 % RH	120 Vac, 60 Hz	Luke Chen

3.3 Duty Cycle of Test Signal

For U-NII-1 Band

MODULATION TYPE: BPSK

802.11a: Duty cycle = 2.023/2.089 = 0.968, Duty factor = $10 \cdot \log(1/0.968) = 0.14$

802.11n (HT20): Duty cycle = 1.883/1.955 = 0.963, Duty factor = $10 \cdot \log(1/0.963) = 0.16$

802.11n (HT40): Duty cycle = 0.584/0.681 = 0.858, Duty factor = $10 \cdot \log(1/0.858) = 0.66$

802.11ac (VHT80): Duty cycle = 0.288/0.384 = 0.750, Duty factor = $10 \cdot \log(1/0.750) = 1.25$

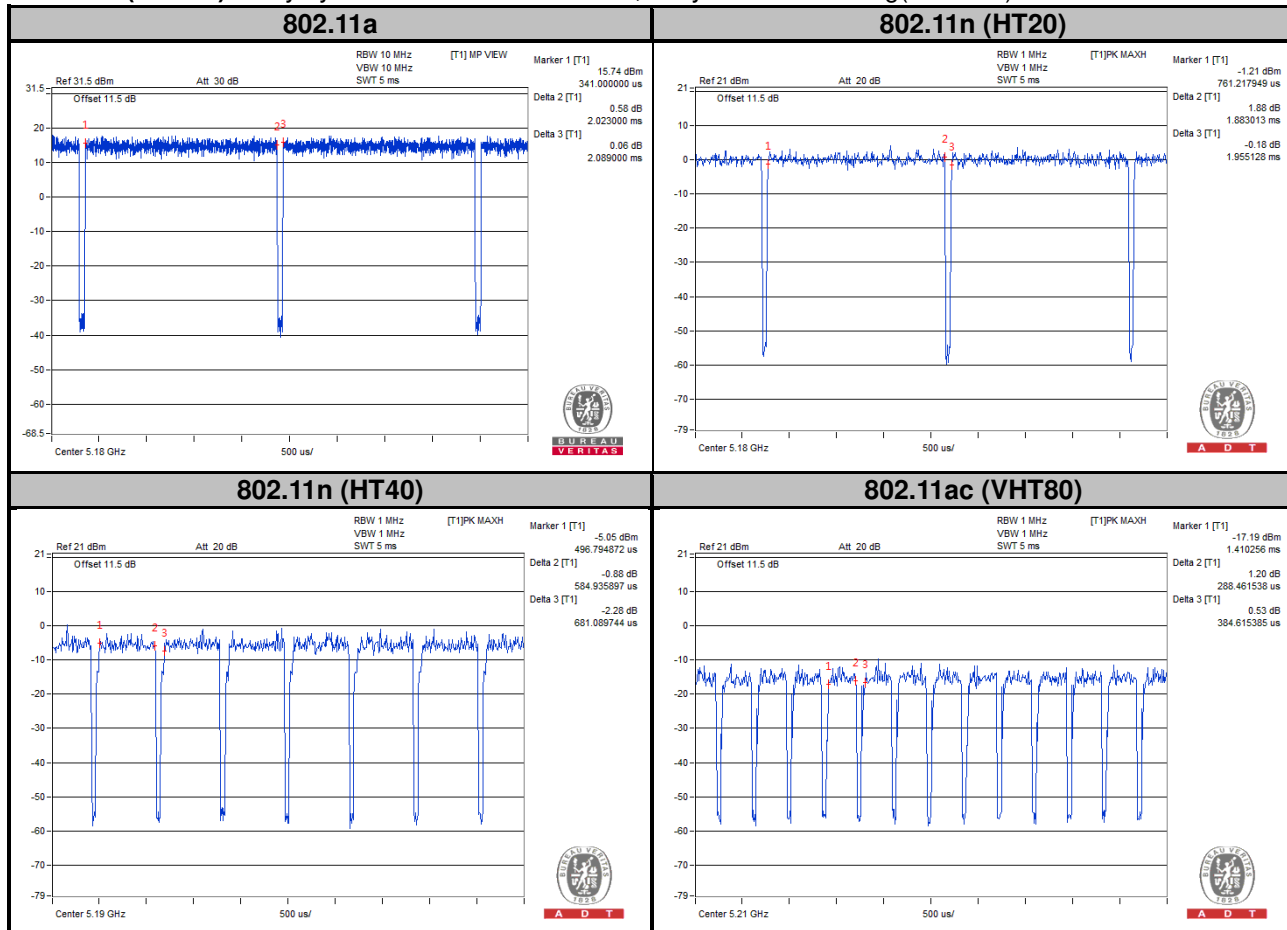

For U-NII-3 Band

MODULATION TYPE: BPSK

802.11a: Duty cycle = 2.025/2.091 = 0.968, Duty factor = $10 * \log(1/0.968) = 0.14$

802.11n (HT20): Duty cycle = 1.886/1.951 = 0.967, Duty factor = $10 * \log(1/0.967) = 0.15$

802.11n (HT40): Duty cycle = 0.621/0.705 = 0.881, Duty factor = $10 * \log(1/0.881) = 0.55$

802.11ac (VHT80): Duty cycle = 0.313/0.386 = 0.811, Duty factor = $10 * \log(1/0.811) = 0.91$

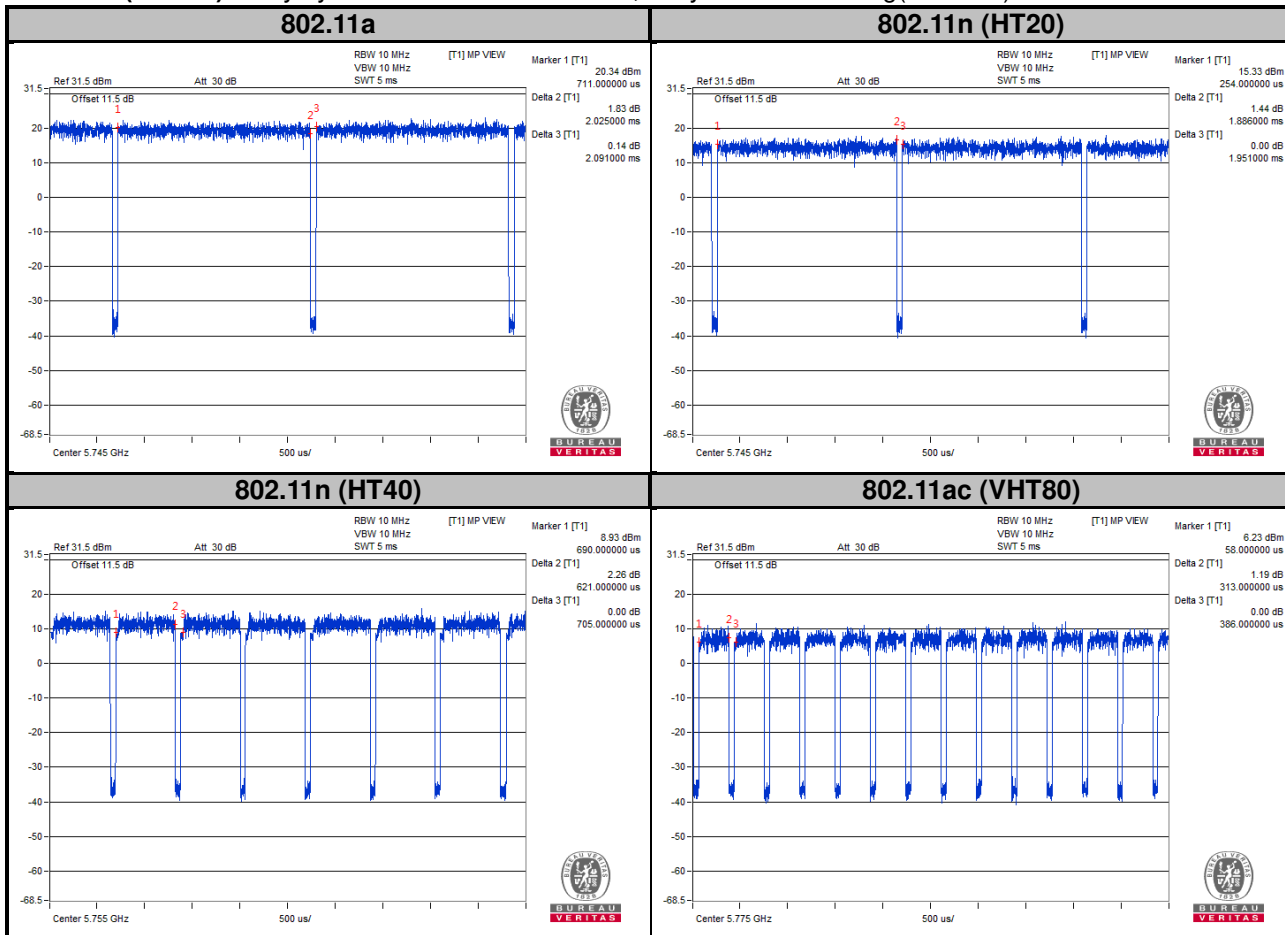

3.4 Description of Support Units

The EUT has been tested as an independent unit together with other necessary accessories or support units. The following support units or accessories were used to form a representative test configuration during the tests.

No.	Product	Brand	Model No.	Serial No.	FCC ID
1.	Notebook	DELL	E6420	D3T96R1	N/A
2.	POE	4ipnet	POE30G	N/A	N/A

No.	Signal Cable Description Of The Above Support Units
1.	N/A
2.	N/A

Note:

1. All power cords of the above support units are non-shielded (1.8m).

3.4.1 Configuration of System under Test

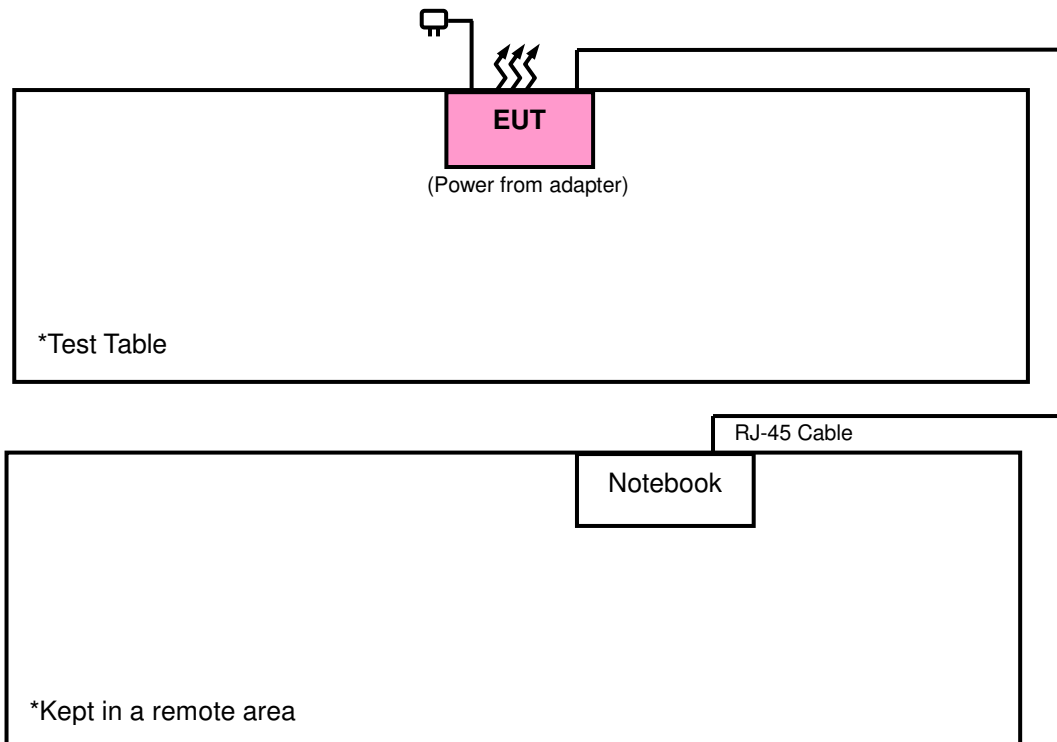

3.5 General Description of Applied Standards

The EUT is a RF Product. According to the specifications of the manufacturer, it must comply with the requirements of the following standards:

FCC Part 15, Subpart E (15.407)

789033 D02 General UNII Test Procedures New Rules v01r04

644545 D01 Guidance for IEEE 802 11ac v01r02

662911 D01 Multiple Transmitter Output v02r01

ANSI C63.10-2013

All test items have been performed and recorded as per the above standards.

Note: The EUT has been verified to comply with the requirements of FCC Part 15, Subpart B, Class B (DoC).
The test report has been issued separately.

4 Test Types and Results

4.1 Radiated Emission and Bandedge Measurement

4.1.1 Limits of Radiated Emission and Bandedge Measurement

Radiated emissions which fall in the restricted bands must comply with the radiated emission limits specified as below table. Other emissions shall be at least 20 dB below the highest level of the desired power:

Frequencies (MHz)	Field Strength (microvolts/meter)	Measurement Distance (meters)
0.009 ~ 0.490	2400/F (kHz)	300
0.490 ~ 1.705	24000/F (kHz)	30
1.705 ~ 30.0	30	30
30 ~ 88	100	3
88 ~ 216	150	3
216 ~ 960	200	3
Above 960	500	3

Note:

1. The lower limit shall apply at the transition frequencies.
2. Emission level (dBuV/m) = 20 log Emission level (uV/m).
3. For frequencies above 1000 MHz, the field strength limits are based on average detector, however, the peak field strength of any emission shall not exceed the maximum permitted average limits, specified above by more than 20 dB under any condition of modulation.

4.1.2 Limits of Unwanted Emission Out of the Restricted Bands

Applicable To		Limit	
789033 D02 General UNII Test Procedures New Rules v01r04		Field Strength at 3 m	
		PK: 74 (dBμV/m)	AV: 54 (dBμV/m)
Frequency Band	Applicable To	EIRP Limit	Equivalent Field Strength at 3 m
5150~5250 MHz	15.407(b)(1)	PK: -27 (dBm/MHz)	PK: 68.2 (dBμV/m)
5250~5350 MHz	15.407(b)(2)		
5470~5725 MHz	15.407(b)(3)		
5725~5850 MHz	15.407(b)(4)(i)	PK:-27 (dBm/MHz) ^{*1} PK:10 (dBm/MHz) ^{*2} PK:15.6 (dBm/MHz) ^{*3} PK:27 (dBm/MHz) ^{*4}	PK: 68.2 (dBμV/m) ^{*1} PK:105.2 (dBμV/m) ^{*2} PK: 110.8 (dBμV/m) ^{*3} PK:122.2 (dBμV/m) ^{*4}
	15.407(b)(4)(ii)	Emission limits in section 15.247(d)	
^{*1} beyond 75 MHz or more above of the band edge. ^{*2} below the band edge increasing linearly to 10 dBm/MHz at 25 MHz above. ^{*3} below the band edge increasing linearly to a level of 15.6 dBm/MHz at 5 MHz above. ^{*4} from 5 MHz above or below the band edge increasing linearly to a level of 27 dBm/MHz at the band edge.			

Note:

The following formula is used to convert the equipment isotropic radiated power (eirp) to field strength:

$$E = \frac{1000000\sqrt{30P}}{3} \mu\text{V/m, where } P \text{ is the eirp (Watts).}$$

4.1.3 Test Instruments

Description & Manufacturer	Model No.	Serial No.	Date of Calibration	Due Date of Calibration
Test Receiver Agilent	N9038A	MY51210203	Feb. 17, 2017	Feb. 16, 2018
Spectrum Analyzer Agilent	N9010A	MY52220314	Dec. 16, 2016	Dec. 15, 2017
Spectrum Analyzer ROHDE & SCHWARZ	FSU43	101261	Dec. 13, 2016	Dec. 12, 2017
BILOG Antenna SCHWARZBECK	VULB9168	9168-472	Dec. 26, 2016	Dec. 27, 2017
HORN Antenna SCHWARZBECK	BBHA 9120 D	9120D-969	Dec. 12, 2016	Dec. 13, 2017
HORN Antenna SCHWARZBECK	BBHA 9170	9170-480	Dec. 14, 2016	Dec. 13, 2017
Fixed Attenuator Mini-Circuits	MDCS18N-10	MDCS18N-10-01	Apr. 17, 2017	Apr. 16, 2018
Loop Antenna	HLA 6121	45745	May 19, 2017	May 18, 2018
Preamplifier EMCI	EMC001340	980201	Nov. 01, 2017	Oct. 31, 2018
Bluetooth Tester	CBT	100946	Jul. 29, 2016	Jul. 28, 2018
Preamplifier EMCI	EMC 012645	980115	Oct. 20, 2017	Oct. 19, 2018
Preamplifier EMCI	EMC 184045	980116	Oct. 20, 2017	Oct. 19, 2018
Preamplifier EMCI	EMC 330H	980112	Oct. 13, 2017	Oct. 12, 2018
Power Meter Anritsu	ML2495A	1012010	Aug. 15, 2017	Aug. 14, 2018
Power Sensor Anritsu	MA2411B	1315050	Aug. 15, 2017	Aug. 14, 2018
RF Coaxial Cable EMCI	5D-NM-BM	140903+140902	Oct. 20, 2017	Oct. 19, 2018
RF Coaxial Cable EMCI	5D-NM-BM	140901	Oct. 20, 2017	Oct. 19, 2018
RF Coaxial Cable Worken	8D-FB	Cable-Ch10-01	Oct. 20, 2017	Oct. 19, 2018
Software BV ADT	E3 6.120103	NA	NA	NA
Antenna Tower MF	MFA-440H	NA	NA	NA
Turn Table MF	MFT-201SS	NA	NA	NA
Antenna Tower & Turn Table Controller MF	MF-7802	NA	NA	NA
Temperature & Humidity Chamber	GTH-120-40-CP-A R	MAA1306-019	Sep. 08, 2017	Sep. 07, 2018
DC Power Supply Topward	33010D	807748	Oct. 25, 2016	Oct. 24, 2018
Digital Multimeter Fluke	87-III	70360742	Jun. 30, 2017	Jun. 29, 2018

- Note:
1. The calibration interval of the above test instruments is 12 / 24 months and the calibrations are traceable to NML/ROC and NIST/USA.
 2. The test was performed in HwaYa Chamber 10.
 3. The horn antenna and preamplifier (model: EMC 184045) are used only for the measurement of emission frequency above 1 GHz if tested.
 4. The IC Site Registration No. is IC7450F-10.

4.1.4 Test Procedures

- a. The EUT was placed on the top of a rotating table 0.8 meters (for below 1 GHz) / 1.5 meters (for above 1 GHz) above the ground at 3 meter chamber room for test. The table was rotated 360 degrees to determine the position of the highest radiation.
- b. The EUT was set 3 meters away from the interference-receiving antenna, which was mounted on the top of a variable-height antenna tower.
- c. The height of antenna is varied from one meter to four meters above the ground to determine the maximum value of the field strength. Both horizontal and vertical polarizations of the antenna are set to make the measurement.
- d. For each suspected emission, the EUT was arranged to its worst case and then the antenna was tuned to heights from 1 meter to 4 meters and the rotatable table was turned from 0 degrees to 360 degrees to find the maximum reading.
- e. The test-receiver system was set to quasi-peak detect function and specified bandwidth with maximum hold mode when the test frequency is below 1 GHz.
- f. The test-receiver system was set to peak and average detected function and specified bandwidth with maximum hold mode when the test frequency is above 1 GHz. If the peak reading value also meets average limit, measurement with the average detector is unnecessary.

Note:

1. The resolution bandwidth and video bandwidth of test receiver/spectrum analyzer is 120 kHz & 360 kHz for Quasi-peak detection (QP) at frequency below 1 GHz.
2. The resolution bandwidth of test receiver/spectrum analyzer is 1 MHz and the video bandwidth is 3 MHz for Peak detection (PK) at frequency above 1 GHz.
3. The resolution bandwidth of test receiver/spectrum analyzer is 1 MHz and the video bandwidth is 1/T for Average (Duty cycle < 98 %) detection at frequency above 1 GHz.
4. The resolution bandwidth of test receiver/spectrum analyzer is 1 MHz and the video bandwidth is 10 Hz (Duty cycle \geq 98 %) for Average detection (AV) at frequency above 1 GHz.
5. All modes of operation were investigated and the worst-case emissions are reported.

4.1.5 Deviation from Test Standard

No deviation.

4.1.6 Test Set Up

<Radiated emission below 30 MHz>

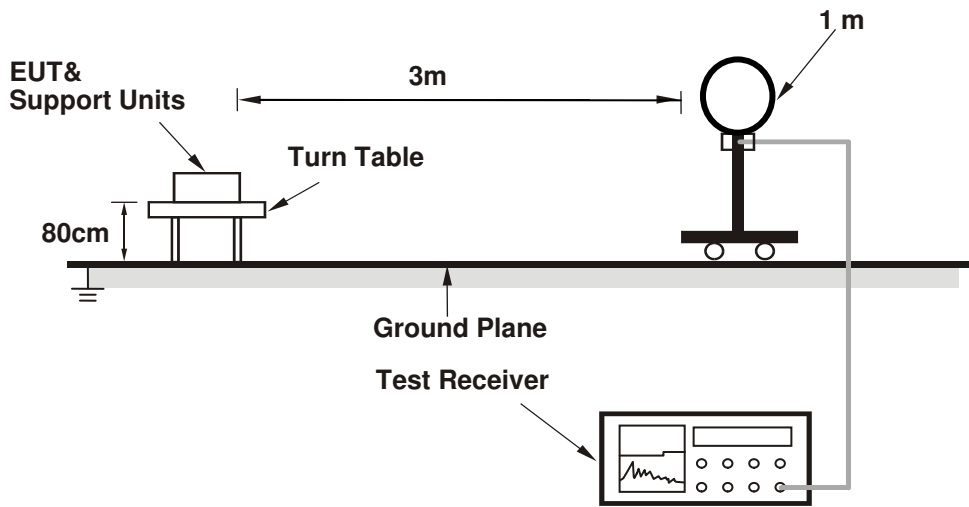

<Frequency Range below 1 GHz>

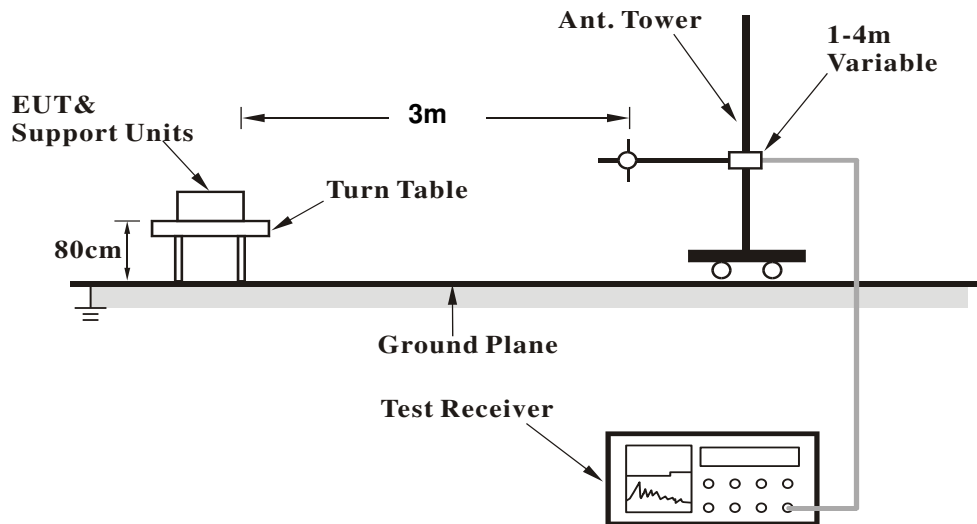

<Frequency Range above 1 GHz>

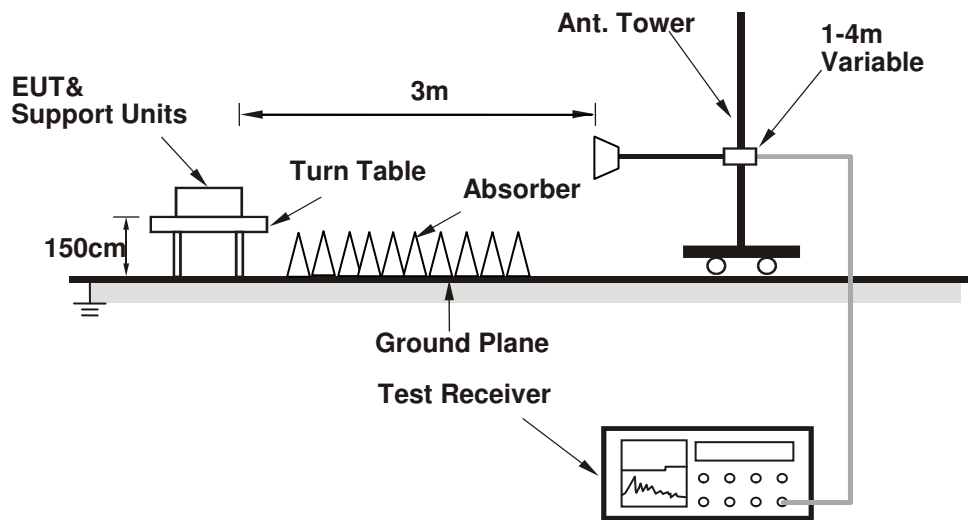

For the actual test configuration, please refer to the attached file (Test Setup Photo).

4.1.7 EUT Operating Conditions

- Placed the EUT on a testing table.
- Use the software to control the EUT under transmission condition continuously at specific channel frequency.

4.1.8 Test Results
 Above 1 GHz Data :
 802.11a

EUT Test Condition		Measurement Detail	
Channel	Channel 36	Frequency Range	1 GHz ~ 40 GHz
Input Power	120 Vac, 60 Hz	Detector Function	Peak (PK) Average (AV)
Environmental Conditions	25 deg. C, 65 % RH	Tested By	Greg Lin

Antenna Polarity & Test Distance: Horizontal at 3 m										
Frequency (MHz)	Emission Level (dBuV/m)	Read Level (dBuV)	Limit (dBuV/m)	Margin (dB)	Antenna Factor (dB/m)	Cable Loss (dB)	Preamp Factor (dB)	Antenna Height (cm)	Table Angle (Degree)	Remark
5148	43.77	35.52	54	-10.23	34.12	8.13	34	124	212	Average
5148	60.95	52.7	74	-13.05	34.12	8.13	34	124	212	Peak
5180	100.64	92.33			34.15	8.16	34	124	212	Average
5180	107.36	99.05			34.15	8.16	34	124	212	Peak
5450	45.39	36.57	54	-8.61	34.36	8.51	34.05	124	212	Average
5450	57.89	49.07	74	-16.11	34.36	8.51	34.05	124	212	Peak

Antenna Polarity & Test Distance: Vertical at 3 m										
Frequency (MHz)	Emission Level (dBuV/m)	Read Level (dBuV)	Limit (dBuV/m)	Margin (dB)	Antenna Factor (dB/m)	Cable Loss (dB)	Preamp Factor (dB)	Antenna Height (cm)	Table Angle (Degree)	Remark
5146	45.77	37.52	54	-8.23	34.12	8.13	34	101	237	Average
5146	60.64	52.39	74	-13.36	34.12	8.13	34	101	237	Peak
5180	102.07	93.76			34.15	8.16	34	101	237	Average
5180	109.03	100.72			34.15	8.16	34	101	237	Peak
5396	45.28	36.56	54	-8.72	34.32	8.44	34.04	101	237	Average
5396	57.99	49.27	74	-16.01	34.32	8.44	34.04	101	237	Peak

Remarks:

- Emission Level = Read Level + Antenna Factor + Cable Loss - Preamp Factor
 Margin value = Emission level – Limit value
- 5180 MHz: Fundamental Frequency
- *: Out of Restricted Band

EUT Test Condition		Measurement Detail	
Channel	Channel 44	Frequency Range	1 GHz ~ 40 GHz
Input Power	120 Vac, 60 Hz	Detector Function	Peak (PK) Average (AV)
Environmental Conditions	25 deg. C, 65 % RH	Tested By	Greg Lin

Antenna Polarity & Test Distance: Horizontal at 3 m										
Frequency (MHz)	Emission Level (dBuV/m)	Read Level (dBuV)	Limit (dBuV/m)	Margin (dB)	Antenna Factor (dB/m)	Cable Loss (dB)	Preamp Factor (dB)	Antenna Height (cm)	Table Angle (Degree)	Remark
5144	44.77	36.52	54	-9.23	34.12	8.13	34	124	211	Average
5144	56.98	48.73	74	-17.02	34.12	8.13	34	124	211	Peak
5220	99.6	91.21			34.17	8.22	34	124	211	Average
5220	107.53	99.14			34.17	8.22	34	124	211	Peak
5450	45.39	36.57	54	-8.61	34.36	8.51	34.05	124	211	Average
5450	56.4	47.58	74	-17.6	34.36	8.51	34.05	124	211	Peak

Antenna Polarity & Test Distance: Vertical at 3 m										
Frequency (MHz)	Emission Level (dBuV/m)	Read Level (dBuV)	Limit (dBuV/m)	Margin (dB)	Antenna Factor (dB/m)	Cable Loss (dB)	Preamp Factor (dB)	Antenna Height (cm)	Table Angle (Degree)	Remark
5112	43.72	35.52	54	-10.28	34.09	8.1	33.99	100	233	Average
5112	56.38	48.18	74	-17.62	34.09	8.1	33.99	100	233	Peak
5220	101.96	93.57			34.17	8.22	34	100	233	Average
5220	108.74	100.35			34.17	8.22	34	100	233	Peak
5366	44.2	35.56	54	-9.8	34.29	8.38	34.03	100	233	Average
5366	57.81	49.17	74	-16.19	34.29	8.38	34.03	100	233	Peak

Remarks:

- Emission Level = Read Level + Antenna Factor + Cable Loss - Preamp Factor
Margin value = Emission level – Limit value
- 5220 MHz: Fundamental Frequency
- *: Out of Restricted Band

EUT Test Condition		Measurement Detail	
Channel	Channel 48	Frequency Range	1 GHz ~ 40 GHz
Input Power	120 Vac, 60 Hz	Detector Function	Peak (PK) Average (AV)
Environmental Conditions	25 deg. C, 65 % RH	Tested By	Greg Lin

Antenna Polarity & Test Distance: Horizontal at 3 m										
Frequency (MHz)	Emission Level (dBuV/m)	Read Level (dBuV)	Limit (dBuV/m)	Margin (dB)	Antenna Factor (dB/m)	Cable Loss (dB)	Preamp Factor (dB)	Antenna Height (cm)	Table Angle (Degree)	Remark
5146	44.76	36.51	54	-9.24	34.12	8.13	34	124	208	Average
5146	56.18	47.93	74	-17.82	34.12	8.13	34	124	208	Peak
5240	100.3	91.86			34.19	8.26	34.01	124	208	Average
5240	107.87	99.43			34.19	8.26	34.01	124	208	Peak
5450	45.39	36.57	54	-8.61	34.36	8.51	34.05	124	208	Average
5450	57.46	48.64	74	-16.54	34.36	8.51	34.05	124	208	Peak

Antenna Polarity & Test Distance: Vertical at 3 m										
Frequency (MHz)	Emission Level (dBuV/m)	Read Level (dBuV)	Limit (dBuV/m)	Margin (dB)	Antenna Factor (dB/m)	Cable Loss (dB)	Preamp Factor (dB)	Antenna Height (cm)	Table Angle (Degree)	Remark
5050	44.57	36.51	54	-9.43	34.04	8	33.98	100	233	Average
5050	57.04	48.98	74	-16.96	34.04	8	33.98	100	233	Peak
5240	101.3	92.86			34.19	8.26	34.01	100	233	Average
5240	108.78	100.34			34.19	8.26	34.01	100	233	Peak
5436	45.35	36.56	54	-8.65	34.35	8.48	34.04	100	233	Average
5436	56.37	47.58	74	-17.63	34.35	8.48	34.04	100	233	Peak

Remarks:

- Emission Level = Read Level + Antenna Factor + Cable Loss - Preamp Factor
Margin value = Emission level – Limit value
- 5240 MHz: Fundamental Frequency
- *: Out of Restricted Band

EUT Test Condition		Measurement Detail	
Channel	Channel 149	Frequency Range	1 GHz ~ 40 GHz
Input Power	120 Vac, 60 Hz	Detector Function	Peak (PK) Average (AV)
Environmental Conditions	25 deg. C, 65 % RH	Tested By	Greg Lin

Antenna Polarity & Test Distance: Horizontal at 3 m							
Frequency (MHz)	Emission Level (dBuV/m)	Limit (dBuV/m)	Margin (dB)	Antenna Height (m)	Table Angle (Degree)	Raw Value (dBuV)	Correction Factor (dB/m)
#5628.80	59.4 PK	68.2	-8.8	3.63 H	348	54.7	4.7
*5745.00	112.2 PK			3.63 H	348	70.7	41.5
*5745.00	101.6 AV			3.63 H	348	60.1	41.5
#5956.00	58.4 PK	68.2	-9.8	3.63 H	348	53.6	4.8
11490.00	59.5 PK	74.0	-14.5	3.07 H	154	43.5	16.0
11490.00	47.6 AV	54.0	-6.4	3.07 H	154	31.6	16.0
Antenna Polarity & Test Distance: Vertical at 3 m							
Frequency (MHz)	Emission Level (dBuV/m)	Limit (dBuV/m)	Margin (dB)	Antenna Height (m)	Table Angle (Degree)	Raw Value (dBuV)	Correction Factor (dB/m)
#5641.60	58.3 PK	68.2	-9.9	3.99 V	243	53.6	4.7
*5745.00	106.2 PK			3.99 V	243	64.7	41.5
*5745.00	96.1 AV			3.99 V	243	54.6	41.5
#5929.60	57.0 PK	68.2	-11.2	3.99 V	243	52.2	4.8
11490.00	58.2 PK	74.0	-15.8	2.47 V	124	42.2	16.0
11490.00	46.4 AV	54.0	-7.6	2.47 V	124	30.4	16.0

Remarks:

1. Emission Level(dBuV/m) = Raw Value(dBuV) + Correction Factor(dB/m)
2. Correction Factor(dB/m) = Antenna Factor(dB/m) + Cable Factor(dB) – Pre-Amplifier Factor(dB)
3. The other emission levels were very low against the limit.
4. Margin value = Emission Level – Limit value
5. " * ": Fundamental frequency.
6. " # ": The radiated frequency is out of the restricted band.

EUT Test Condition		Measurement Detail	
Channel	Channel 157	Frequency Range	1 GHz ~ 40 GHz
Input Power	120 Vac, 60 Hz	Detector Function	Peak (PK) Average (AV)
Environmental Conditions	25 deg. C, 65 % RH	Tested By	Greg Lin

Antenna Polarity & Test Distance: Horizontal at 3 m							
Frequency (MHz)	Emission Level (dBuV/m)	Limit (dBuV/m)	Margin (dB)	Antenna Height (m)	Table Angle (Degree)	Raw Value (dBuV)	Correction Factor (dB/m)
#5631.20	57.9 PK	68.2	-10.3	3.12 H	339	53.2	4.7
*5785.00	112.1 PK			3.12 H	339	70.6	41.5
*5785.00	101.9 AV			3.12 H	339	60.4	41.5
#5963.20	58.1 PK	68.2	-10.1	3.12 H	339	53.3	4.8
11570.00	58.2 PK	74.0	-15.8	3.42 H	271	42.5	15.7
11570.00	46.5 AV	54.0	-7.5	3.42 H	271	30.8	15.7
Antenna Polarity & Test Distance: Vertical at 3 m							
Frequency (MHz)	Emission Level (dBuV/m)	Limit (dBuV/m)	Margin (dB)	Antenna Height (m)	Table Angle (Degree)	Raw Value (dBuV)	Correction Factor (dB/m)
#5615.20	56.7 PK	68.2	-11.5	3.75 V	232	51.9	4.8
*5785.00	106.4 PK			3.75 V	232	64.9	41.5
*5785.00	96.3 AV			3.75 V	232	54.8	41.5
#5928.00	57.5 PK	68.2	-10.7	3.75 V	232	52.7	4.8
11570.00	56.9 PK	74.0	-17.1	2.17 V	348	41.2	15.7
11570.00	45.4 AV	54.0	-8.6	2.17 V	348	29.7	15.7

Remarks:

1. Emission Level(dBuV/m) = Raw Value(dBuV) + Correction Factor(dB/m)
2. Correction Factor(dB/m) = Antenna Factor(dB/m) + Cable Factor(dB) – Pre-Amplifier Factor(dB)
3. The other emission levels were very low against the limit.
4. Margin value = Emission Level – Limit value
5. " * ": Fundamental frequency.
6. " # ": The radiated frequency is out of the restricted band.

EUT Test Condition		Measurement Detail	
Channel	Channel 165	Frequency Range	1 GHz ~ 40 GHz
Input Power	120 Vac, 60 Hz	Detector Function	Peak (PK) Average (AV)
Environmental Conditions	25 deg. C, 65 % RH	Tested By	Greg Lin

Antenna Polarity & Test Distance: Horizontal at 3 m							
Frequency (MHz)	Emission Level (dBuV/m)	Limit (dBuV/m)	Margin (dB)	Antenna Height (m)	Table Angle (Degree)	Raw Value (dBuV)	Correction Factor (dB/m)
#5627.20	58.0 PK	68.2	-10.2	3.67 H	321	53.3	4.7
*5825.00	111.6 PK			3.67 H	321	70.0	41.6
*5825.00	100.8 AV			3.67 H	321	59.2	41.6
#5931.20	58.0 PK	68.2	-10.2	3.67 H	321	53.2	4.8
11650.00	57.8 PK	74.0	-16.2	1.47 H	258	42.2	15.6
11650.00	46.2 AV	54.0	-7.8	1.47 H	258	30.6	15.6
Antenna Polarity & Test Distance: Vertical at 3 m							
Frequency (MHz)	Emission Level (dBuV/m)	Limit (dBuV/m)	Margin (dB)	Antenna Height (m)	Table Angle (Degree)	Raw Value (dBuV)	Correction Factor (dB/m)
#5617.60	57.7 PK	68.2	-10.5	3.76 V	233	52.9	4.8
*5825.00	106.4 PK			3.76 V	233	64.8	41.6
*5825.00	96.1 AV			3.76 V	233	54.5	41.6
#5988.80	57.6 PK	68.2	-10.6	3.76 V	233	52.8	4.8
11650.00	56.4 PK	74.0	-17.6	3.38 V	256	40.8	15.6
11650.00	45.0 AV	54.0	-9.0	3.38 V	256	29.4	15.6

Remarks:

1. Emission Level(dBuV/m) = Raw Value(dBuV) + Correction Factor(dB/m)
2. Correction Factor(dB/m) = Antenna Factor(dB/m) + Cable Factor(dB) – Pre-Amplifier Factor(dB)
3. The other emission levels were very low against the limit.
4. Margin value = Emission Level – Limit value
5. " * ": Fundamental frequency.
6. " # ": The radiated frequency is out of the restricted band.

802.11n (HT20)

EUT Test Condition		Measurement Detail	
Channel	Channel 36	Frequency Range	1 GHz ~ 40 GHz
Input Power	120 Vac, 60 Hz	Detector Function	Peak (PK) Average (AV)
Environmental Conditions	25 deg. C, 65 % RH	Tested By	Greg Lin

Antenna Polarity & Test Distance: Horizontal at 3 m

Frequency (MHz)	Emission Level (dBuV/m)	Read Level (dBuV)	Limit (dBuV/m)	Margin (dB)	Antenna Factor (dB/m)	Cable Loss (dB)	Preamp Factor (dB)	Antenna Height (cm)	Table Angle (Degree)	Remark
5148	45.82	37.57	54	-8.18	34.12	8.13	34	101	205	Average
5148	56.57	48.32	74	-17.43	34.12	8.13	34	101	205	Peak
5180	100.71	92.4			34.15	8.16	34	101	205	Average
5180	107.09	98.78			34.15	8.16	34	101	205	Peak
5424	46.38	37.61	54	-7.62	34.33	8.48	34.04	101	205	Average
5424	57.12	48.35	74	-16.88	34.33	8.48	34.04	101	205	Peak

Antenna Polarity & Test Distance: Vertical at 3 m

Frequency (MHz)	Emission Level (dBuV/m)	Read Level (dBuV)	Limit (dBuV/m)	Margin (dB)	Antenna Factor (dB/m)	Cable Loss (dB)	Preamp Factor (dB)	Antenna Height (cm)	Table Angle (Degree)	Remark
5142	46.77	38.51	54	-7.23	34.12	8.13	33.99	110	173	Average
5142	61.58	53.32	74	-12.42	34.12	8.13	33.99	110	173	Peak
5180	103.67	95.36			34.15	8.16	34	110	173	Average
5180	110.1	101.79			34.15	8.16	34	110	173	Peak
5420	46.38	37.61	54	-7.62	34.33	8.48	34.04	110	173	Average
5420	57.33	48.56	74	-16.67	34.33	8.48	34.04	110	173	Peak

Remarks:

- Emission Level = Read Level + Antenna Factor + Cable Loss - Preamp Factor
Margin value = Emission level – Limit value
- 5180 MHz: Fundamental Frequency
- *: Out of Restricted Band

EUT Test Condition		Measurement Detail	
Channel	Channel 44	Frequency Range	1 GHz ~ 40 GHz
Input Power	120 Vac, 60 Hz	Detector Function	Peak (PK) Average (AV)
Environmental Conditions	25 deg. C, 65 % RH	Tested By	Greg Lin

Antenna Polarity & Test Distance: Horizontal at 3 m										
Frequency (MHz)	Emission Level (dBuV/m)	Read Level (dBuV)	Limit (dBuV/m)	Margin (dB)	Antenna Factor (dB/m)	Cable Loss (dB)	Preamp Factor (dB)	Antenna Height (cm)	Table Angle (Degree)	Remark
5082	45.69	37.53	54	-8.31	34.07	8.07	33.98	103	205	Average
5082	56.97	48.81	74	-17.03	34.07	8.07	33.98	103	205	Peak
5220	101.76	93.37			34.17	8.22	34	103	205	Average
5220	108.42	100.03			34.17	8.22	34	103	205	Peak
5446	46.44	37.61	54	-7.56	34.36	8.51	34.04	103	205	Average
5446	56.88	48.05	74	-17.12	34.36	8.51	34.04	103	205	Peak

Antenna Polarity & Test Distance: Vertical at 3 m										
Frequency (MHz)	Emission Level (dBuV/m)	Read Level (dBuV)	Limit (dBuV/m)	Margin (dB)	Antenna Factor (dB/m)	Cable Loss (dB)	Preamp Factor (dB)	Antenna Height (cm)	Table Angle (Degree)	Remark
5150	45.82	37.57	54	-8.18	34.12	8.13	34	110	172	Average
5150	56.79	48.54	74	-17.21	34.12	8.13	34	110	172	Peak
5220	103.63	95.24			34.17	8.22	34	110	172	Average
5220	110.59	102.2			34.17	8.22	34	110	172	Peak
5420	45.38	36.61	54	-8.62	34.33	8.48	34.04	110	172	Average
5420	57.87	49.1	74	-16.13	34.33	8.48	34.04	110	172	Peak

Remarks:

- Emission Level = Read Level + Antenna Factor + Cable Loss - Preamp Factor
Margin value = Emission level – Limit value
- 5220 MHz: Fundamental Frequency
- *: Out of Restricted Band

EUT Test Condition		Measurement Detail	
Channel	Channel 48	Frequency Range	1 GHz ~ 40 GHz
Input Power	120 Vac, 60 Hz	Detector Function	Peak (PK) Average (AV)
Environmental Conditions	25 deg. C, 65 % RH	Tested By	Greg Lin

Antenna Polarity & Test Distance: Horizontal at 3 m										
Frequency (MHz)	Emission Level (dBuV/m)	Read Level (dBuV)	Limit (dBuV/m)	Margin (dB)	Antenna Factor (dB/m)	Cable Loss (dB)	Preamp Factor (dB)	Antenna Height (cm)	Table Angle (Degree)	Remark
5074	45.67	37.55	54	-8.33	34.07	8.03	33.98	101	205	Average
5074	56.54	48.42	74	-17.46	34.07	8.03	33.98	101	205	Peak
5240	100.68	92.24			34.19	8.26	34.01	101	205	Average
5240	107.77	99.33			34.19	8.26	34.01	101	205	Peak
5440	46.42	37.63	54	-7.58	34.35	8.48	34.04	101	205	Average
5440	58.43	49.64	74	-15.57	34.35	8.48	34.04	101	205	Peak

Antenna Polarity & Test Distance: Vertical at 3 m										
Frequency (MHz)	Emission Level (dBuV/m)	Read Level (dBuV)	Limit (dBuV/m)	Margin (dB)	Antenna Factor (dB/m)	Cable Loss (dB)	Preamp Factor (dB)	Antenna Height (cm)	Table Angle (Degree)	Remark
5096	45.71	37.55	54	-8.29	34.08	8.07	33.99	110	172	Average
5096	56.69	48.53	74	-17.31	34.08	8.07	33.99	110	172	Peak
5240	104.01	95.57			34.19	8.26	34.01	110	172	Average
5240	110.39	101.95			34.19	8.26	34.01	110	172	Peak
5416	46.35	37.62	54	-7.65	34.33	8.44	34.04	110	172	Average
5416	58.07	49.34	74	-15.93	34.33	8.44	34.04	110	172	Peak

Remarks:

- Emission Level = Read Level + Antenna Factor + Cable Loss - Preamp Factor
Margin value = Emission level – Limit value
- 5240 MHz: Fundamental Frequency
- *: Out of Restricted Band

Channel	Channel 149	Frequency Range	1 GHz ~ 40 GHz
Input Power	120 Vac, 60 Hz	Detector Function	Peak (PK) Average (AV)
Environmental Conditions	25 deg. C, 65 % RH	Tested By	Greg Lin

Antenna Polarity & Test Distance: Horizontal at 3 m							
Frequency (MHz)	Emission Level (dBuV/m)	Limit (dBuV/m)	Margin (dB)	Antenna Height (m)	Table Angle (Degree)	Raw Value (dBuV)	Correction Factor (dB/m)
#5632.00	58.4 PK	68.2	-9.8	3.48 H	124	53.7	4.7
*5745.00	112.1 PK			3.48 H	124	70.6	41.5
*5745.00	101.9 AV			3.48 H	124	60.4	41.5
#5932.00	58.4 PK	68.2	-9.8	3.48 H	124	53.6	4.8
11490.00	58.1 PK	74.0	-15.9	2.38 H	201	42.1	16.0
11490.00	46.6 AV	54.0	-7.4	2.38 H	201	30.6	16.0
Antenna Polarity & Test Distance: Vertical at 3 m							
Frequency (MHz)	Emission Level (dBuV/m)	Limit (dBuV/m)	Margin (dB)	Antenna Height (m)	Table Angle (Degree)	Raw Value (dBuV)	Correction Factor (dB/m)
#5643.20	57.4 PK	68.2	-10.8	4.00 V	179	52.7	4.7
*5745.00	106.7 PK			4.00 V	179	65.2	41.5
*5745.00	96.2 AV			4.00 V	179	54.7	41.5
#5970.40	57.9 PK	68.2	-10.3	4.00 V	179	53.1	4.8
11490.00	56.8 PK	74.0	-17.2	1.72 V	314	40.8	16.0
11490.00	45.4 AV	54.0	-8.6	1.72 V	314	29.4	16.0

Remarks:

1. Emission Level(dBuV/m) = Raw Value(dBuV) + Correction Factor(dB/m)
2. Correction Factor(dB/m) = Antenna Factor(dB/m) + Cable Factor(dB) – Pre-Amplifier Factor(dB)
3. The other emission levels were very low against the limit.
4. Margin value = Emission Level – Limit value
5. " * ": Fundamental frequency.
6. " # ": The radiated frequency is out of the restricted band.

EUT Test Condition		Measurement Detail	
Channel	Channel 157	Frequency Range	1 GHz ~ 40 GHz
Input Power	120 Vac, 60 Hz	Detector Function	Peak (PK) Average (AV)
Environmental Conditions	25 deg. C, 65 % RH	Tested By	Greg Lin

Antenna Polarity & Test Distance: Horizontal at 3 m							
Frequency (MHz)	Emission Level (dBuV/m)	Limit (dBuV/m)	Margin (dB)	Antenna Height (m)	Table Angle (Degree)	Raw Value (dBuV)	Correction Factor (dB/m)
#5631.20	58.2 PK	68.2	-10.0	3.50 H	118	53.5	4.7
*5785.00	113.0 PK			3.50 H	118	71.5	41.5
*5785.00	102.7 AV			3.50 H	118	61.2	41.5
#5964.00	57.6 PK	68.2	-10.6	3.50 H	118	52.8	4.8
11570.00	58.0 PK	74.0	-16.0	2.91 H	311	42.3	15.7
11570.00	46.1 AV	54.0	-7.9	2.91 H	311	30.4	15.7
Antenna Polarity & Test Distance: Vertical at 3 m							
Frequency (MHz)	Emission Level (dBuV/m)	Limit (dBuV/m)	Margin (dB)	Antenna Height (m)	Table Angle (Degree)	Raw Value (dBuV)	Correction Factor (dB/m)
#5607.20	57.2 PK	68.2	-11.0	3.80 V	183	52.4	4.8
*5785.00	107.2 PK			3.80 V	183	65.7	41.5
*5785.00	96.0 AV			3.80 V	183	54.5	41.5
#5936.00	57.0 PK	68.2	-11.2	3.80 V	183	52.2	4.8
11570.00	56.6 PK	74.0	-17.4	2.91 V	203	40.9	15.7
11570.00	45.3 AV	54.0	-8.7	2.91 V	203	29.6	15.7

Remarks:

1. Emission Level(dBuV/m) = Raw Value(dBuV) + Correction Factor(dB/m)
2. Correction Factor(dB/m) = Antenna Factor(dB/m) + Cable Factor(dB) – Pre-Amplifier Factor(dB)
3. The other emission levels were very low against the limit.
4. Margin value = Emission Level – Limit value
5. " * ": Fundamental frequency.
6. " # ": The radiated frequency is out of the restricted band.

EUT Test Condition		Measurement Detail	
Channel	Channel 165	Frequency Range	1 GHz ~ 40 GHz
Input Power	120 Vac, 60 Hz	Detector Function	Peak (PK) Average (AV)
Environmental Conditions	25 deg. C, 65 % RH	Tested By	Greg Lin

Antenna Polarity & Test Distance: Horizontal at 3 m							
Frequency (MHz)	Emission Level (dBuV/m)	Limit (dBuV/m)	Margin (dB)	Antenna Height (m)	Table Angle (Degree)	Raw Value (dBuV)	Correction Factor (dB/m)
#5618.40	58.6 PK	68.2	-9.6	3.48 H	120	53.8	4.8
*5825.00	112.5 PK			3.48 H	120	70.9	41.6
*5825.00	102.3 AV			3.48 H	120	60.7	41.6
#5939.20	57.6 PK	68.2	-10.6	3.48 H	120	52.8	4.8
11650.00	57.4 PK	74.0	-16.6	2.64 H	138	41.8	15.6
11650.00	46.3 AV	54.0	-7.7	2.64 H	138	30.7	15.6
Antenna Polarity & Test Distance: Vertical at 3 m							
Frequency (MHz)	Emission Level (dBuV/m)	Limit (dBuV/m)	Margin (dB)	Antenna Height (m)	Table Angle (Degree)	Raw Value (dBuV)	Correction Factor (dB/m)
#5605.60	57.1 PK	68.2	-11.1	3.82 V	205	52.3	4.8
*5825.00	106.2 PK			3.82 V	205	64.6	41.6
*5825.00	96.0 AV			3.82 V	205	54.4	41.6
#6000.00	56.8 PK	68.2	-11.4	3.82 V	205	52.0	4.8
11650.00	56.7 PK	74.0	-17.3	1.32 V	96	41.1	15.6
11650.00	45.1 AV	54.0	-8.9	1.32 V	96	29.5	15.6

Remarks:

1. Emission Level(dBuV/m) = Raw Value(dBuV) + Correction Factor(dB/m)
2. Correction Factor(dB/m) = Antenna Factor(dB/m) + Cable Factor(dB) – Pre-Amplifier Factor(dB)
3. The other emission levels were very low against the limit.
4. Margin value = Emission Level – Limit value
5. " * ": Fundamental frequency.
6. " # ": The radiated frequency is out of the restricted band.

802.11n (HT40)

EUT Test Condition		Measurement Detail	
Channel	Channel 38	Frequency Range	1 GHz ~ 40 GHz
Input Power	120 Vac, 60 Hz	Detector Function	Peak (PK) Average (AV)
Environmental Conditions	25 deg. C, 65 % RH	Tested By	Greg Lin

Antenna Polarity & Test Distance: Horizontal at 3 m

Frequency (MHz)	Emission Level (dBuV/m)	Read Level (dBuV)	Limit (dBuV/m)	Margin (dB)	Antenna Factor (dB/m)	Cable Loss (dB)	Preamp Factor (dB)	Antenna Height (cm)	Table Angle (Degree)	Remark
5150	46.82	38.57	54	-7.18	34.12	8.13	34	104	205	Average
5150	57.85	49.6	74	-16.15	34.12	8.13	34	104	205	Peak
5190	98.74	90.4			34.15	8.19	34	104	205	Average
5190	105.62	97.28			34.15	8.19	34	104	205	Peak
5432	46.39	37.6	54	-7.61	34.35	8.48	34.04	104	205	Average
5432	57.99	49.2	74	-16.01	34.35	8.48	34.04	104	205	Peak

Antenna Polarity & Test Distance: Vertical at 3 m

Frequency (MHz)	Emission Level (dBuV/m)	Read Level (dBuV)	Limit (dBuV/m)	Margin (dB)	Antenna Factor (dB/m)	Cable Loss (dB)	Preamp Factor (dB)	Antenna Height (cm)	Table Angle (Degree)	Remark
5150	49.91	41.66	54	-4.09	34.12	8.13	34	112	199	Average
5150	59.7	51.45	74	-14.3	34.12	8.13	34	112	199	Peak
5190	101.23	92.89			34.15	8.19	34	110	171	Average
5190	108.26	99.92			34.15	8.19	34	110	171	Peak
5430	46.39	37.6	54	-7.61	34.35	8.48	34.04	110	171	Average
5430	57.43	48.64	74	-16.57	34.35	8.48	34.04	110	171	Peak

Remarks:

- Emission Level = Read Level + Antenna Factor + Cable Loss - Preamp Factor
Margin value = Emission level – Limit value
- 5190 MHz: Fundamental Frequency
- *: Out of Restricted Band

EUT Test Condition		Measurement Detail	
Channel	Channel 46	Frequency Range	1 GHz ~ 40 GHz
Input Power	120 Vac, 60 Hz	Detector Function	Peak (PK) Average (AV)
Environmental Conditions	25 deg. C, 65 % RH	Tested By	Greg Lin

Antenna Polarity & Test Distance: Horizontal at 3 m										
Frequency (MHz)	Emission Level (dBuV/m)	Read Level (dBuV)	Limit (dBuV/m)	Margin (dB)	Antenna Factor (dB/m)	Cable Loss (dB)	Preamp Factor (dB)	Antenna Height (cm)	Table Angle (Degree)	Remark
5062	45.66	37.56	54	-8.34	34.05	8.03	33.98	104	205	Average
5062	56.48	48.38	74	-17.52	34.05	8.03	33.98	104	205	Peak
5230	99.78	91.38			34.19	8.22	34.01	104	205	Average
5230	106.12	97.72			34.19	8.22	34.01	104	205	Peak
5450	46.76	37.94	54	-7.24	34.36	8.51	34.05	104	205	Average
5450	56.95	48.13	74	-17.05	34.36	8.51	34.05	104	205	Peak

Antenna Polarity & Test Distance: Vertical at 3 m										
Frequency (MHz)	Emission Level (dBuV/m)	Read Level (dBuV)	Limit (dBuV/m)	Margin (dB)	Antenna Factor (dB/m)	Cable Loss (dB)	Preamp Factor (dB)	Antenna Height (cm)	Table Angle (Degree)	Remark
5150	47.84	39.59	54	-6.16	34.12	8.13	34	106	208	Average
5150	60.65	52.4	74	-13.35	34.12	8.13	34	106	208	Peak
5230	101.38	92.98			34.19	8.22	34.01	106	208	Average
5230	108.09	99.69			34.19	8.22	34.01	106	208	Peak
5450	46.44	37.62	54	-7.56	34.36	8.51	34.05	106	208	Average
5450	58.82	50	74	-15.18	34.36	8.51	34.05	106	208	Peak

Remarks:

- Emission Level = Read Level + Antenna Factor + Cable Loss - Preamp Factor
Margin value = Emission level – Limit value
- 5230 MHz: Fundamental Frequency
- *: Out of Restricted Band

EUT Test Condition		Measurement Detail	
Channel	Channel 151	Frequency Range	1 GHz ~ 40 GHz
Input Power	120 Vac, 60 Hz	Detector Function	Peak (PK) Average (AV)
Environmental Conditions	25 deg. C, 65 % RH	Tested By	Greg Lin

Antenna Polarity & Test Distance: Horizontal at 3 m							
Frequency (MHz)	Emission Level (dBuV/m)	Limit (dBuV/m)	Margin (dB)	Antenna Height (m)	Table Angle (Degree)	Raw Value (dBuV)	Correction Factor (dB/m)
#5611.20	58.1 PK	68.2	-10.1	3.73 H	154	53.3	4.8
*5755.00	109.1 PK			3.73 H	154	67.6	41.5
*5755.00	98.8 AV			3.73 H	154	57.3	41.5
#5950.40	57.5 PK	68.2	-10.7	3.73 H	154	52.7	4.8
11510.00	58.2 PK	74.0	-15.8	1.36 H	269	42.3	15.9
11510.00	46.6 AV	54.0	-7.4	1.36 H	269	30.7	15.9
Antenna Polarity & Test Distance: Vertical at 3 m							
Frequency (MHz)	Emission Level (dBuV/m)	Limit (dBuV/m)	Margin (dB)	Antenna Height (m)	Table Angle (Degree)	Raw Value (dBuV)	Correction Factor (dB/m)
#5609.60	57.7 PK	68.2	-10.5	3.81 V	73	52.9	4.8
*5755.00	106.3 PK			3.81 V	73	64.8	41.5
*5755.00	96.2 AV			3.81 V	73	54.7	41.5
#5948.80	58.1 PK	68.2	-10.1	3.81 V	73	53.3	4.8
11510.00	56.5 PK	74.0	-17.5	3.61 V	225	40.6	15.9
11510.00	45.2 AV	54.0	-8.8	3.61 V	225	29.3	15.9

Remarks:

1. Emission Level(dBuV/m) = Raw Value(dBuV) + Correction Factor(dB/m)
2. Correction Factor(dB/m) = Antenna Factor(dB/m) + Cable Factor(dB) – Pre-Amplifier Factor(dB)
3. The other emission levels were very low against the limit.
4. Margin value = Emission Level – Limit value
5. " * ": Fundamental frequency.
6. " # ": The radiated frequency is out of the restricted band.

EUT Test Condition		Measurement Detail	
Channel	Channel 159	Frequency Range	1 GHz ~ 40 GHz
Input Power	120 Vac, 60 Hz	Detector Function	Peak (PK) Average (AV)
Environmental Conditions	25 deg. C, 65 % RH	Tested By	Greg Lin

Antenna Polarity & Test Distance: Horizontal at 3 m							
Frequency (MHz)	Emission Level (dBuV/m)	Limit (dBuV/m)	Margin (dB)	Antenna Height (m)	Table Angle (Degree)	Raw Value (dBuV)	Correction Factor (dB/m)
#5642.40	57.7 PK	68.2	-10.5	3.71 H	119	53.0	4.7
*5795.00	110.8 PK			3.71 H	119	69.3	41.5
*5795.00	99.6 AV			3.71 H	119	58.1	41.5
#5944.80	57.1 PK	68.2	-11.1	3.71 H	119	52.3	4.8
11590.00	57.3 PK	74.0	-16.7	1.09 H	351	41.8	15.5
11590.00	46.2 AV	54.0	-7.8	1.09 H	351	30.7	15.5
Antenna Polarity & Test Distance: Vertical at 3 m							
Frequency (MHz)	Emission Level (dBuV/m)	Limit (dBuV/m)	Margin (dB)	Antenna Height (m)	Table Angle (Degree)	Raw Value (dBuV)	Correction Factor (dB/m)
#5640.00	57.6 PK	68.2	-10.6	3.85 V	82	52.9	4.7
*5795.00	106.3 PK			3.85 V	82	64.8	41.5
*5795.00	95.6 AV			3.85 V	82	54.1	41.5
#5932.80	57.3 PK	68.2	-10.9	3.85 V	82	52.5	4.8
11590.00	56.1 PK	74.0	-17.9	2.79 V	138	40.6	15.5
11590.00	44.9 AV	54.0	-9.1	2.79 V	138	29.4	15.5

Remarks:

REMARKS:

1. Emission Level(dBuV/m) = Raw Value(dBuV) + Correction Factor(dB/m)
2. Correction Factor(dB/m) = Antenna Factor(dB/m) + Cable Factor(dB) – Pre-Amplifier Factor(dB)
3. The other emission levels were very low against the limit.
4. Margin value = Emission Level – Limit value
5. " * ": Fundamental frequency.
6. " # ": The radiated frequency is out of the restricted band.

802.11ac (VHT80)

EUT Test Condition		Measurement Detail	
Channel	Channel 42	Frequency Range	1 GHz ~ 40 GHz
Input Power	120 Vac, 60 Hz	Detector Function	Peak (PK) Average (AV)
Environmental Conditions	25 deg. C, 65 % RH	Tested By	Greg Lin

Antenna Polarity & Test Distance: Horizontal at 3 m

Frequency (MHz)	Emission Level (dBuV/m)	Read Level (dBuV)	Limit (dBuV/m)	Margin (dB)	Antenna Factor (dB/m)	Cable Loss (dB)	Preamp Factor (dB)	Antenna Height (cm)	Table Angle (Degree)	Remark
5150	52.82	44.57	54	-1.18	34.12	8.13	34	146	202	Average
5150	64.82	56.57	74	-9.18	34.12	8.13	34	146	202	Peak
5210	88.75	80.39			34.17	8.19	34	101	205	Average
5210	95.69	87.33			34.17	8.19	34	101	205	Peak
5366	45.2	36.56	54	-8.8	34.29	8.38	34.03	101	205	Average
5366	53.61	44.97	74	-20.39	34.29	8.38	34.03	101	205	Peak

Antenna Polarity & Test Distance: Vertical at 3 m

Frequency (MHz)	Emission Level (dBuV/m)	Read Level (dBuV)	Limit (dBuV/m)	Margin (dB)	Antenna Factor (dB/m)	Cable Loss (dB)	Preamp Factor (dB)	Antenna Height (cm)	Table Angle (Degree)	Remark
5150	52.64	44.39	54	-1.36	34.12	8.13	34	141	173	Average
5150	61.94	53.69	74	-12.06	34.12	8.13	34	141	173	Peak
5210	89.93	81.57			34.17	8.19	34	110	172	Average
5210	97.62	89.26			34.17	8.19	34	110	172	Peak
5458	46.39	37.57	54	-7.61	34.36	8.51	34.05	110	172	Average
5458	53.56	44.74	74	-20.44	34.36	8.51	34.05	110	172	Peak

Remarks:

- Emission Level = Read Level + Antenna Factor + Cable Loss - Preamp Factor
Margin value = Emission level – Limit value
- 5210 MHz: Fundamental Frequency
- *: Out of Restricted Band

EUT Test Condition		Measurement Detail	
Channel	Channel 155	Frequency Range	1 GHz ~ 40 GHz
Input Power	120 Vac, 60 Hz	Detector Function	Peak (PK) Average (AV)
Environmental Conditions	25 deg. C, 65 % RH	Tested By	Greg Lin

Antenna Polarity & Test Distance: Horizontal at 3 m							
Frequency (MHz)	Emission Level (dBuV/m)	Limit (dBuV/m)	Margin (dB)	Antenna Height (m)	Table Angle (Degree)	Raw Value (dBuV)	Correction Factor (dB/m)
#5640.80	58.6 PK	68.2	-9.6	3.76 H	117	53.9	4.7
*5775.00	108.9 PK			3.76 H	117	67.4	41.5
*5775.00	96.0 AV			3.76 H	117	54.5	41.5
#5930.40	57.9 PK	68.2	-10.3	3.76 H	117	53.1	4.8
11550.00	57.2 PK	74.0	-16.8	2.88 H	307	41.4	15.8
11550.00	46.4 AV	54.0	-7.6	2.88 H	307	30.6	15.8
Antenna Polarity & Test Distance: Vertical at 3 m							
Frequency (MHz)	Emission Level (dBuV/m)	Limit (dBuV/m)	Margin (dB)	Antenna Height (m)	Table Angle (Degree)	Raw Value (dBuV)	Correction Factor (dB/m)
#5600.80	58.1 PK	68.2	-10.1	4.00 V	77	53.3	4.8
*5775.00	104.1 PK			4.00 V	77	62.6	41.5
*5775.00	92.0 AV			4.00 V	77	50.5	41.5
#5948.80	58.4 PK	68.2	-9.8	4.00 V	77	53.6	4.8
11550.00	56.6 PK	74.0	-17.4	1.59 V	346	40.8	15.8
11550.00	45.2 AV	54.0	-8.8	1.59 V	346	29.4	15.8

Remarks:

1. Emission Level(dBuV/m) = Raw Value(dBuV) + Correction Factor(dB/m)
2. Correction Factor(dB/m) = Antenna Factor(dB/m) + Cable Factor(dB) – Pre-Amplifier Factor(dB)
3. The other emission levels were very low against the limit.
4. Margin value = Emission Level – Limit value
5. " * ": Fundamental frequency.
6. " # ": The radiated frequency is out of the restricted band.

9 kHz ~ 30 MHz Data:

The amplitude of spurious emissions attenuated more than 20 dB below the permissible value is not required to be report.

30 MHz ~ 1 GHz Worst-Case Data:

802.11ac (VHT80)

EUT Test Condition		Measurement Detail	
Channel	Channel 42	Frequency Range	30 MHz ~ 1 GHz
Input Power	120 Vac, 60 Hz	Detector Function	Peak (PK) Quasi-peak (QP)
Environmental Conditions	25 deg. C, 65 % RH	Tested By	Greg Lin

Antenna Polarity & Test Distance: Horizontal at 3 m										
Frequency (MHz)	Emission Level (dBuV/m)	Read Level (dBuV)	Limit (dBuV/m)	Margin (dB)	Antenna Factor (dB/m)	Cable Loss (dB)	Preamp Factor (dB)	Antenna Height (cm)	Table Angle (Degree)	Remark
91.83	35.65	57.3	43.5	-7.85	9.06	1.11	31.82	102	312	Peak
168.24	32.78	53.35	43.5	-10.72	10.15	1.52	32.24	107	42	Peak
280.56	31.17	47.51	46	-14.83	13.75	2.03	32.12	132	285	Peak
339.9	39.26	53.26	46	-6.74	15.89	2.19	32.08	100	185	Peak
599.6	30.8	39.02	46	-15.2	21.1	2.87	32.19	100	320	Peak
624.8	35.18	42.32	46	-10.82	22.1	2.93	32.17	100	47	Peak
Antenna Polarity & Test Distance: Vertical at 3 m										
Frequency (MHz)	Emission Level (dBuV/m)	Read Level (dBuV)	Limit (dBuV/m)	Margin (dB)	Antenna Factor (dB/m)	Cable Loss (dB)	Preamp Factor (dB)	Antenna Height (cm)	Table Angle (Degree)	Remark
37.83	29.61	48.57	40	-10.39	12.53	0.74	32.23	108	52	Peak
94.26	36.21	57.77	43.5	-7.29	9.26	1.11	31.93	186	334	Peak
166.62	34.07	54.51	43.5	-9.43	10.29	1.52	32.25	134	49	Peak
337.8	36.09	50.18	46	-9.91	15.8	2.19	32.08	100	174	Peak
499.5	32.85	43.32	46	-13.15	19	2.63	32.1	100	332	Peak
825	38.21	43.25	46	-7.79	23.5	3.38	31.92	100	285	Peak

Remarks:

- Emission Level = Read Level + Antenna Factor + Cable Loss - Preamp Factor
Margin value = Emission level – Limit value

802.11a

EUT Test Condition		Measurement Detail	
Channel	Channel 149	Frequency Range	30 MHz ~ 1 GHz
Input Power	120 Vac, 60 Hz	Detector Function	Peak (PK) Quasi-peak (QP)
Environmental Conditions	25 deg. C, 65 % RH	Tested By	Greg Lin

Antenna Polarity & Test Distance: Horizontal at 3 m

Frequency (MHz)	Emission Level (dBuV/m)	Read Level (dBuV)	Limit (dBuV/m)	Margin (dB)	Antenna Factor (dB/m)	Cable Loss (dB)	Preamp Factor (dB)	Antenna Height (cm)	Table Angle (Degree)	Remark
96.96	32	53.36	43.5	-11.5	9.46	1.28	32.1	119	37	Peak
166.35	34.17	54.61	43.5	-9.33	10.29	1.52	32.25	134	75	Peak
284.07	33.55	49.87	46	-12.45	13.77	2.03	32.12	235	124	Peak
374.9	38.12	51.71	46	-7.88	16.3	2.26	32.15	107	88	Peak
599.6	36.98	45.2	46	-9.02	21.1	2.87	32.19	189	47	Peak
875.4	29.35	32.69	46	-16.65	24.8	3.49	31.63	132	116	Peak

Antenna Polarity & Test Distance: Vertical at 3 m

Frequency (MHz)	Emission Level (dBuV/m)	Read Level (dBuV)	Limit (dBuV/m)	Margin (dB)	Antenna Factor (dB/m)	Cable Loss (dB)	Preamp Factor (dB)	Antenna Height (cm)	Table Angle (Degree)	Remark
43.77	28.07	49.54	40	-11.93	9.85	0.9	32.22	207	61	Peak
95.07	31.29	52.7	43.5	-12.21	9.3	1.28	31.99	137	96	Peak
169.32	34.83	55.48	43.5	-8.67	10.07	1.52	32.24	164	187	Peak
374.9	31.76	45.35	46	-14.24	16.3	2.26	32.15	144	36	Peak
599.6	34.99	43.21	46	-11.01	21.1	2.87	32.19	109	167	Peak
899.2	35.07	38.07	46	-10.93	25	3.49	31.49	227	312	Peak

Remarks:

- Emission Level = Read Level + Antenna Factor + Cable Loss - Preamp Factor
Margin value = Emission level – Limit value

4.2 Conducted Emission Measurement

4.2.1 Limits of Conducted Emission Measurement

Frequency (MHz)	Conducted Limit (dBuV)	
	Quasi-peak	Average
0.15 - 0.5	66 - 56	56 - 46
0.50 - 5.0	56	46
5.0 - 30.0	60	50

- Note: 1. The lower limit shall apply at the transition frequencies.
 2. The limit decreases in line with the logarithm of the frequency in the range of 0.15 to 0.50 MHz.

4.2.2 Test Instruments

Description & Manufacturer	Model No.	Serial No.	Date Of Calibration	Due Date Of Calibration
Test Receiver ROHDE & SCHWARZ	ESCS 30	100288	Aug. 17, 2017	Aug. 16, 2018
RF signal cable (with 10dB PAD) Woken	5D-FB	Cable-cond2-01	Sep. 08, 2017	Sep. 07, 2018
LISN/AMN ROHDE & SCHWARZ (EUT)	ESH2-Z5	100100	Jan. 17, 2017	Jan. 16, 2018
LISN/AMN ROHDE & SCHWARZ (Peripheral)	ESH3-Z5	100312	Aug. 02, 2017	Aug. 01, 2018
Software ADT	BV ADT_Cond_ V7.3.7.3	NA	NA	NA

- Note: 1. The calibration interval of the above test instruments is 12 months and the calibrations are traceable to NML/ROC and NIST/USA.
 2. The test was performed in HwaYa Shielded Room 2.
 3. The VCCI Site Registration No. is C-2047.

4.2.3 Test Procedures

- a. The EUT was placed 0.4 meters from the conducting wall of the shielded room with EUT being connected to the power mains through a line impedance stabilization network (LISN). Other support units were connected to the power mains through another LISN. The two LISNs provide 50 ohm/ 50uH of coupling impedance for the measuring instrument.
- b. Both lines of the power mains connected to the EUT were checked for maximum conducted interference.
- c. The frequency range from 150 kHz to 30 MHz was searched. Emission levels under (Limit -20 dB) was not recorded.

Note: All modes of operation were investigated and the worst-case emissions are reported.

4.2.4 Deviation from Test Standard

No deviation.

4.2.5 Test Setup

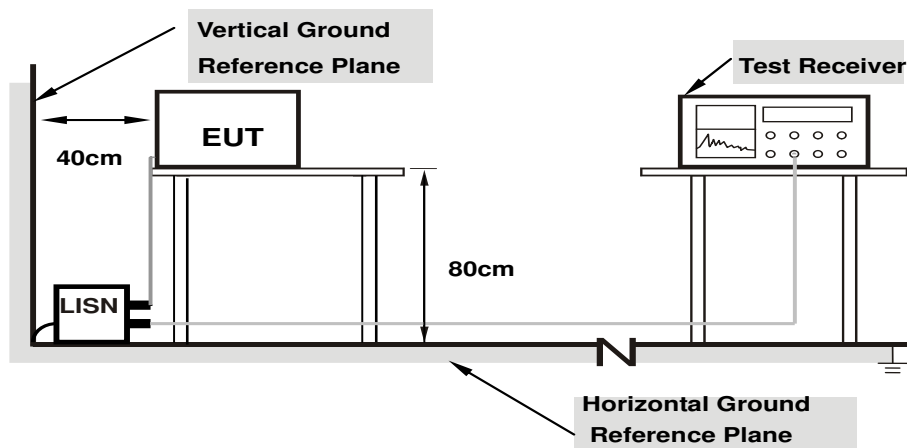

- Note:**
1. Support units were connected to second LISN.
 2. Both of LISNs (AMN) are 80 cm from EUT and at least 80 from other units and other metal planes

For the actual test configuration, please refer to the attached file (Test Setup Photo).

4.2.6 EUT Operating Conditions

- a. Placed the EUT on a testing table.
- b. Use the software to control the EUT under transmission condition continuously at specific channel frequency.

4.2.7 Test Results

Frequency Range	150kHz ~ 30MHz	Detector Function & Resolution Bandwidth	Quasi-Peak (QP), 9kHz Average (AV), 9kHz
Input Power	120Vac, 60Hz	Environmental Conditions	25°C, 65%RH
POWER SUPPLY	Adapter		

Phase Of Power : Line (L)										
No	Frequency (MHz)	Correction Factor (dB)	Reading Value (dBuV)		Emission Level (dBuV)		Limit (dBuV)		Margin (dB)	
			Q.P.	AV.	Q.P.	AV.	Q.P.	AV.	Q.P.	AV.
1	0.17734	0.27	48.08	41.09	48.35	41.36	64.61	54.61	-16.26	-13.25
2	0.32578	0.29	42.55	26.45	42.84	26.74	59.56	49.56	-16.72	-22.82
3	0.46250	0.30	45.75	30.05	46.05	30.35	56.65	46.65	-10.59	-16.29
4	0.92344	0.33	38.07	26.36	38.40	26.69	56.00	46.00	-17.60	-19.31
5	1.38672	0.35	36.18	29.04	36.53	29.39	56.00	46.00	-19.47	-16.61
6	15.01172	0.53	27.76	20.67	28.29	21.20	60.00	50.00	-31.71	-28.80

Remarks:

1. Q.P. and AV. are abbreviations of quasi-peak and average individually.
2. The emission levels of other frequencies were very low against the limit.
3. Margin value = Emission level – Limit value
4. Correction factor = Insertion loss + Cable loss
5. Emission Level = Correction Factor + Reading Value

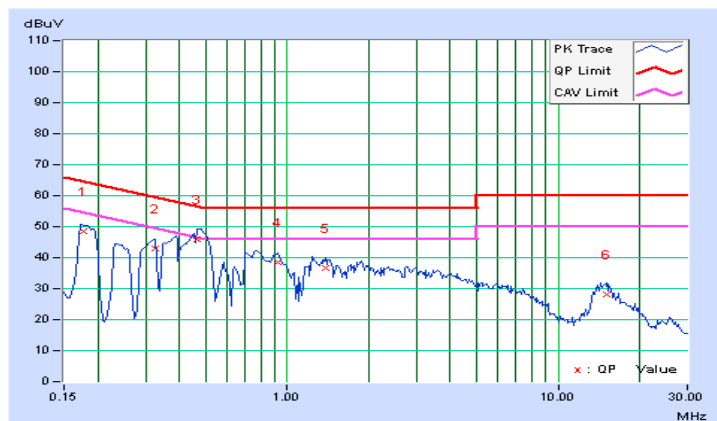

Frequency Range	150kHz ~ 30MHz	Detector Function & Resolution Bandwidth	Quasi-Peak (QP), 9kHz Average (AV), 9kHz
Input Power	120Vac, 60Hz	Environmental Conditions	25°C, 65%RH
POWER SUPPLY	Adapter		

Phase Of Power : Neutral (N)										
No	Frequency (MHz)	Correction Factor (dB)	Reading Value (dBuV)		Emission Level (dBuV)		Limit (dBuV)		Margin (dB)	
			Q.P.	AV.	Q.P.	AV.	Q.P.	AV.	Q.P.	AV.
1	0.18125	0.27	45.98	39.87	46.25	40.14	64.43	54.43	-18.17	-14.28
2	0.46250	0.30	46.60	30.97	46.90	31.27	56.65	46.65	-9.74	-15.37
3	0.75938	0.32	38.95	28.97	39.27	29.29	56.00	46.00	-16.73	-16.71
4	1.39844	0.35	35.74	27.84	36.09	28.19	56.00	46.00	-19.91	-17.81
5	6.07422	0.47	25.41	20.28	25.88	20.75	60.00	50.00	-34.12	-29.25
6	15.01563	0.57	25.79	18.61	26.36	19.18	60.00	50.00	-33.64	-30.82

Remarks:

1. Q.P. and AV. are abbreviations of quasi-peak and average individually.
2. The emission levels of other frequencies were very low against the limit.
3. Margin value = Emission level – Limit value
4. Correction factor = Insertion loss + Cable loss
5. Emission Level = Correction Factor + Reading Value

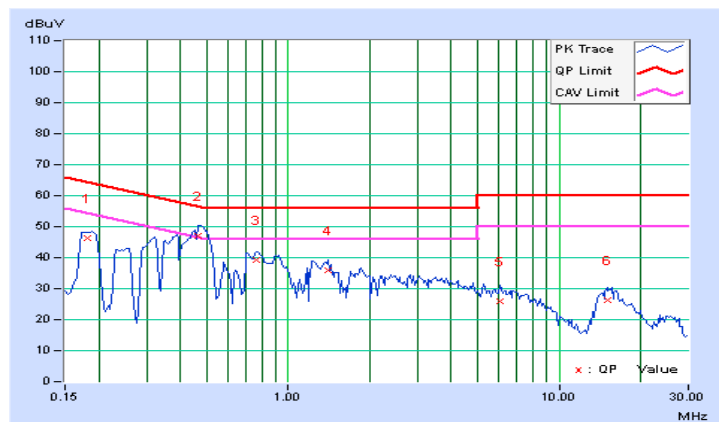

4.3 Transmit Power Measurement

4.3.1 Limits of Transmit Power Measurement

Operation Band	EUT Category		Limit
U-NII-1		Outdoor Access Point	1 Watt (30 dBm) (Max. e.i.r.p \leq 125 mW (21 dBm) at any elevation angle above 30 degrees as measured from the horizon)
		Fixed point-to-point Access Point	1 Watt (30 dBm)
	√	Indoor Access Point	1 Watt (30 dBm)
		Mobile and Portable client device	250 mW (24 dBm)
U-NII-2A	-		250 mW (24 dBm) or 11 dBm + 10 log B*
U-NII-2C	-		250 mW (24 dBm) or 11 dBm + 10 log B*
U-NII-3	√		1 Watt (30 dBm)

*B is the 26 dB emission bandwidth in megahertz

Per KDB 662911 Method of conducted output power measurement on IEEE 802.11 devices,

Array Gain = 0 dB (i.e., no array gain) for $N_{ANT} \leq 4$;

Array Gain = 0 dB (i.e., no array gain) for channel widths ≥ 40 MHz for any N_{ANT} ;

Array Gain = $5 \log(N_{ANT}/N_{SS})$ dB or 3 dB, whichever is less for 20 MHz channel widths with $N_{ANT} \geq 5$.

For power measurements on all other devices: Array Gain = $10 \log(N_{ANT}/N_{SS})$ dB.

4.3.2 Test Setup

<Power Output Measurement>

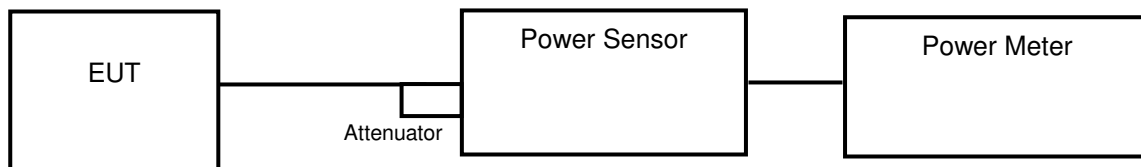

or

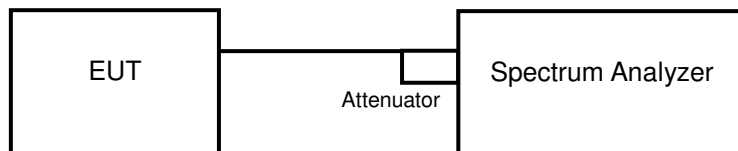

<26 dB Bandwidth>

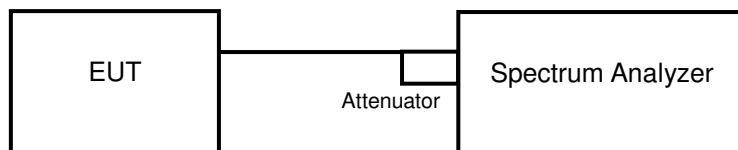

4.3.3 Test Instruments

Refer to section 4.1.2 to get information of above instrument.

4.3.4 Test Procedure

Average Power Measurement

<802.11a, 802.11n (HT20), 802.11n (HT40)>

Method PM is used to perform output power measurement, trigger and gating function of wide band power meter is enabled to measure max output power of TX on burst. Duty factor is not added to measured value.

<802.11ac (VHT80)>

Method SA-1 is used to perform output power measurement, trigger and gating function of spectrum analyzer is enabled to measure max output power of TX on burst. Duty factor is not added to measured value.

26 dB Bandwidth

- 1) Set RBW = approximately 1 % of the emission bandwidth.
- 2) Set the VBW > RBW.
- 3) Detector = Peak.
- 4) Trace mode = max hold.
- 5) Measure the maximum width of the emission that is 26 dB down from the peak of the emission. Compare this with the RBW setting of the analyzer. Readjust RBW and repeat measurement as needed until the RBW/EBW ratio is approximately 1 %.

4.3.5 Deviation from Test Standard

No deviation.

4.3.6 EUT Operating Conditions

The software provided by client to enable the EUT under transmission condition continuously at lowest, middle and highest channel frequencies individually.

4.3.7 Test Result

Power Output:
802.11a

Channel	Frequency (MHz)	Maximum Conducted Power (mW)	Maximum Conducted Power (dBm)	Power Limit (dBm)	Pass / Fail
36	5180	39.084	15.92	30	Pass
44	5220	39.628	15.98	30	Pass
48	5240	39.537	15.97	30	Pass
149	5745	94.406	19.75	30	Pass
157	5785	86.497	19.37	30	Pass
165	5825	94.624	19.76	30	Pass

802.11n (HT20)

Channel	Frequency (MHz)	Maximum Conducted Power (dBm)			Total Power (mW)	Total Power (dBm)	Power Limit (dBm)	Pass / Fail
		Chain 0	Chain 1	Chain 2				
36	5180	7.68	8.65	8.07	19.60	12.92	30	Pass
44	5220	7.89	8.43	8.46	20.13	13.04	30	Pass
48	5240	7.74	8.54	8.37	19.96	13.00	30	Pass
149	5745	14.71	15.40	15.24	97.674	19.90	30	Pass
157	5785	14.94	15.19	15.16	97.036	19.87	30	Pass
165	5825	14.32	15.22	15.20	93.419	19.70	30	Pass

802.11n (HT40)

Channel	Frequency (MHz)	Maximum Conducted Power (dBm)			Total Power (mW)	Total Power (dBm)	Power Limit (dBm)	Pass / Fail
		Chain 0	Chain 1	Chain 2				
38	5190	10.21	10.87	10.29	33.40	15.24	30	Pass
46	5230	10.31	10.84	10.69	34.60	15.39	30	Pass
151	5755	14.38	15.29	15.44	96.217	19.83	30	Pass
159	5795	14.43	15.38	15.36	96.603	19.85	30	Pass

802.11ac (VHT80)

Channel	Frequency (MHz)	Maximum Conducted Power (dBm)			Total Power (mW)	Total Power (dBm)	Power Limit (dBm)	Pass / Fail
		Chain 0	Chain 1	Chain 2				
42	5210	4.14	4.59	3.73	7.83	8.94	30	Pass
155	5775	14.10	15.24	14.39	86.603	19.38	30	Pass

26 dB Bandwidth:
802.11a

Channel	Frequency (MHz)	26 dBc Bandwidth (MHz)
36	5180	25.00
44	5220	25.93
48	5240	25.16

802.11n (HT20)

Channel	Frequency (MHz)	26 dBc Bandwidth (MHz)		
		Chain 0	Chain 1	Chain 2
36	5180	25.69	25.14	24.95
44	5220	26.40	24.96	25.29
48	5240	25.72	26.00	24.84

802.11n (HT40)

Channel	Frequency (MHz)	26 dBc Bandwidth (MHz)		
		Chain 0	Chain 1	Chain 2
38	5190	48.98	48.97	47.05
46	5230	49.69	47.89	48.19

802.11ac (VHT80)

Channel	Frequency (MHz)	26 dBc Bandwidth (MHz)		
		Chain 0	Chain 1	Chain 2
42	5210	101.01	100.82	101.02

Spectrum Plot of Worst Value

802.11a

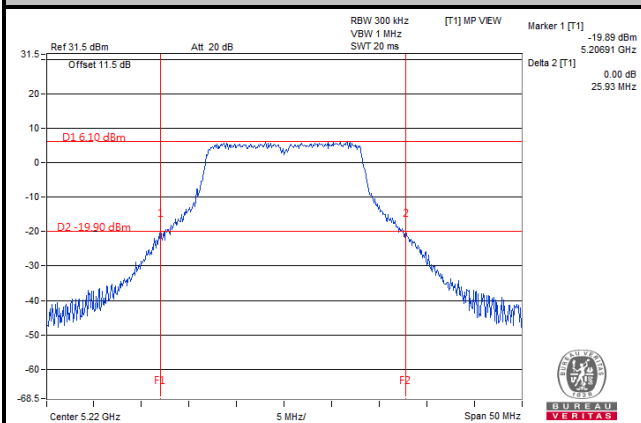

802.11n (HT20)

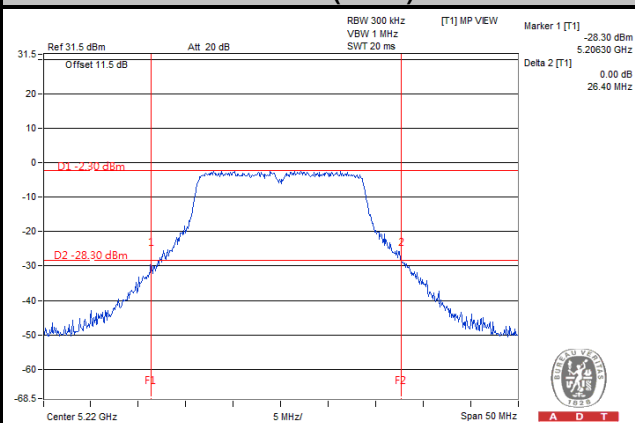

802.11n (HT40)

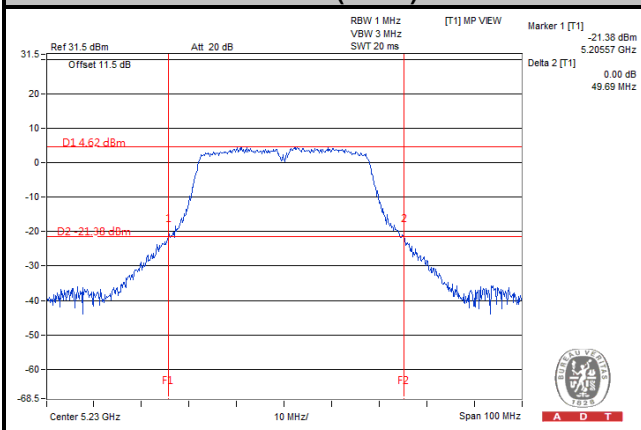

802.11ac (VHT80)

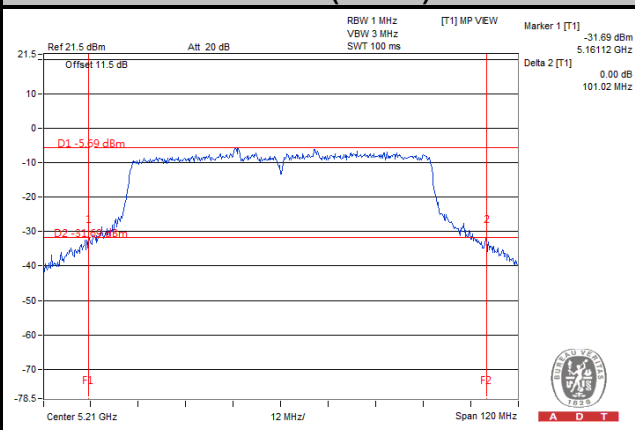

4.4 Occupied Bandwidth Measurement

4.4.1 Test Setup



4.4.2 Test Instruments

Refer to section 4.1.2 to get information of above instrument.

4.4.3 Test Procedure

The transmitter output was connected to the spectrum analyzer through an attenuator. The bandwidth of the fundamental frequency was measured by spectrum analyzer with resolution bandwidth in the range of 1 % to 5 % of the anticipated emission bandwidth, and a video bandwidth at least 3x the resolution bandwidth and set the detector to SAMPLE. The width of a frequency band such that, below the lower and above the upper frequency limits, the mean powers emitted are each equal to a specified percentage 0.5 % of the total mean power of a given emission.

4.4.4 Test Results

802.11a

Channel	Channel Frequency (MHz)	Occupied Bandwidth (MHz)
36	5180	17.16
40	5200	17.06
48	5240	17.11
149	5745	17.01
157	5785	17.00
165	5825	16.95

802.11n (HT20)

Channel	Channel Frequency (MHz)	Occupied Bandwidth (MHz)		
		Chain 0	Chain 1	Chain 2
36	5180	18.17	18.08	18.03
40	5200	18.17	18.12	18.03
48	5240	18.17	18.12	18.22
149	5745	17.88	18.07	17.88
157	5785	18.05	18.15	18.02
165	5825	17.95	18.10	18.15

802.11n (HT40)

Channel	Channel Frequency (MHz)	Occupied Bandwidth (MHz)		
		Chain 0	Chain 1	Chain 2
38	5190	37.31	37.31	37.18
46	5230	37.31	37.18	37.05
151	5755	37.00	36.69	36.85
159	5795	36.85	36.83	36.66

802.11ac (VHT80)

Channel	Channel Frequency (MHz)	Occupied Bandwidth (MHz)		
		Chain 0	Chain 1	Chain 2
42	5210	75.96	75.96	75.96
155	5775	76.20	76.12	75.96

Spectrum Plot of Worst Value

802.11a

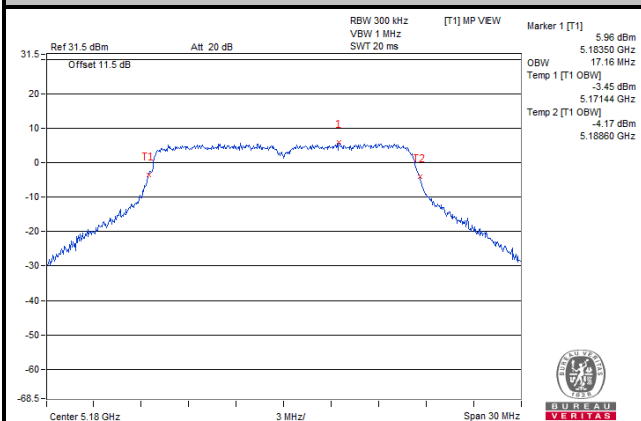

802.11n (HT20)

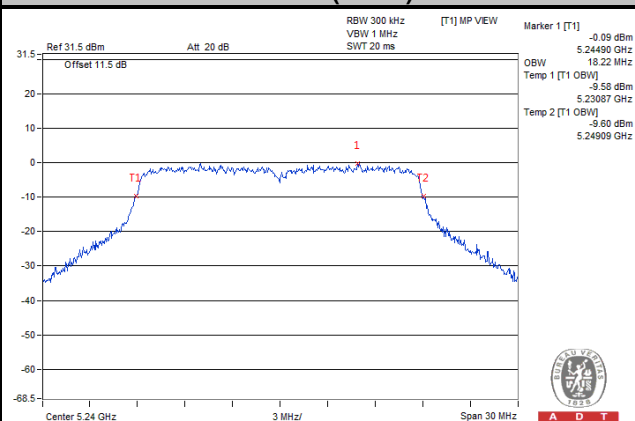

802.11n (HT40)

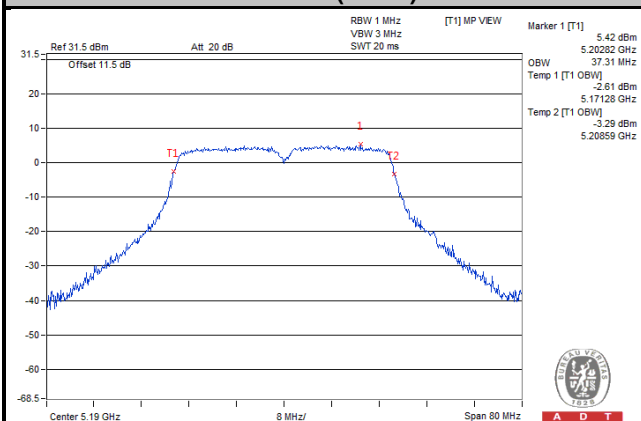

802.11ac (VHT80)

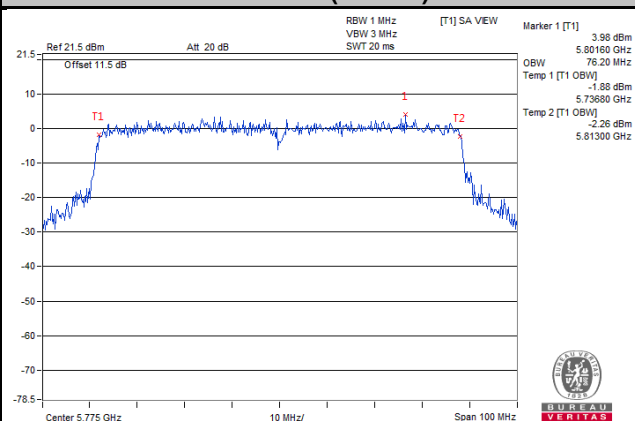

4.5 Peak Power Spectral Density Measurement

4.5.1 Limits of Peak Power Spectral Density Measurement

Operation Band	EUT Category		Limit
U-NII-1		Outdoor Access Point	17 dBm/MHz
		Fixed point-to-point Access Point	
	√	Indoor Access Point	
		Mobile and Portable client device	11 dBm/MHz
U-NII-2A		√	11 dBm/MHz
U-NII-2C		√	11 dBm/MHz
U-NII-3		√	30 dBm/500 kHz

4.5.2 Test Setup

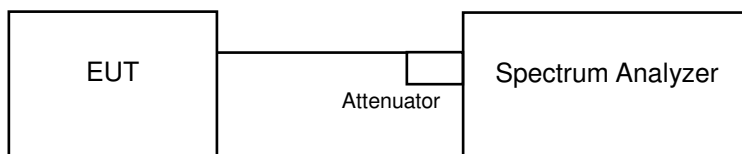

4.5.3 Test Instruments

Refer to section 4.1.3 to get information of above instrument.

4.5.4 Test Procedures

For U-NII-1 band:

Using method SA-2

1. Set span to encompass the entire emission bandwidth (EBW) of the signal.
2. Set RBW = 1 MHz, Set VBW \geq 3 RBW, Detector = RMS
3. Sweep time = auto, trigger set to "free run".
4. Trace average at least 100 traces in power averaging mode.
5. Record the max value and add 10 log (1/duty cycle)

※For U-NII-3:

1. Set span to encompass the entire emission bandwidth (EBW) of the signal.
2. Set RBW = 500 kHz, Set VBW \geq 3 RBW, Detector = RMS
3. Use the peak marker function to determine the maximum power level in any 500 kHz band segment within the fundamental EBW.
4. Sweep time = auto, trigger set to "free run".
5. Trace average at least 100 traces in power averaging mode.
6. Record the max value and add 10 log (1/duty cycle)

4.5.5 Deviation from Test Standard

No deviation.

4.5.6 EUT Operating Conditions

The software provided by client to enable the EUT under transmission condition continuously at lowest, middle and highest channel frequencies individually.

4.5.7 Test Results

For U-NII-1, U-NII-2A, U-NII-2C Band

802.11a

Channel	Frequency (MHz)	PSD w/o Duty Factor (dBm/MHz)	Duty Factor (dB)	PSD with Duty Factor (dBm/MHz)	Maximum Limit (dBm/MHz)	Pass / Fail
36	5180	2.25	0.14	2.39	11	Pass
44	5220	2.59	0.14	2.73	11	Pass
48	5240	2.49	0.14	2.63	11	Pass

Note: Refer to section 3.3 for duty cycle spectrum plot.

802.11n (HT20)

Channel	Frequency (MHz)	PSD (dBm/MHz)			Duty Factor (dB)	Total PSD with Duty Factor (dBm/MHz)	Max. Limit (dBm/MHz)	Pass / Fail
		Chain 0	Chain 1	Chain 2				
36	5180	-5.72	-3.88	-4.16	0.16	0.42	7.99	Pass
44	5220	-5.81	-3.34	-4.42	0.16	0.53	7.99	Pass
48	5240	-5.91	-3.34	-4.59	0.16	0.45	7.99	Pass

Note:

- Method 1 of power density measurement of KDB 662911 is using for calculating total power density. Total power density is summing entire spectra across corresponding frequency bins on the various outputs by computer.
- Directional gain = $10 \log[(10^{G1/20} + 10^{G2/20} + \dots + 10^{GN/20})^2 / N_{ANT}] = 9.01 \text{dBi} > 6 \text{dBi}$, so the power density limit shall be reduced to $11 - (9.01 - 6) = 7.99 \text{dBm}$.
- Refer to section 3.3 for duty cycle spectrum plot.

802.11n (HT40)

Channel	Frequency (MHz)	PSD (dBm/MHz)			Duty Factor (dB)	Total PSD with Duty Factor (dBm/MHz)	Max. Limit (dBm/MHz)	Pass / Fail
		Chain 0	Chain 1	Chain 2				
38	5190	-6.38	-4.59	-4.46	0.66	0.37	7.99	Pass
46	5230	-6.99	-4.35	-4.21	0.66	0.42	7.99	Pass

Note:

- Method 1 of power density measurement of KDB 662911 is using for calculating total power density. Total power density is summing entire spectra across corresponding frequency bins on the various outputs by computer.
- Directional gain = $10 \log[(10^{G1/20} + 10^{G2/20} + \dots + 10^{GN/20})^2 / N_{ANT}] = 9.01 \text{dBi} > 6 \text{dBi}$, so the power density limit shall be reduced to $11 - (9.01 - 6) = 7.99 \text{dBm}$.
- Refer to section 3.3 for duty cycle spectrum plot.

802.11ac (VHT80)

Channel	Frequency (MHz)	PSD (dBm/MHz)			Duty Factor (dB)	Total PSD with Duty Factor (dBm/MHz)	Max. Limit (dBm/MHz)	Pass / Fail
		Chain 0	Chain 1	Chain 2				
42	5210	-15.16	-14.25	-15.43	1.25	-8.90	7.99	Pass

Note:

- Method 1 of power density measurement of KDB 662911 is using for calculating total power density. Total power density is summing entire spectra across corresponding frequency bins on the various outputs by computer.
- Directional gain = $10 \log[(10^{G1/20} + 10^{G2/20} + \dots + 10^{GN/20})^2 / N_{ANT}] = 9.01\text{dBi} > 6\text{dBi}$, so the power density limit shall be reduced to $11 - (9.01 - 6) = 7.99\text{dBm}$.
- Refer to section 3.3 for duty cycle spectrum plot.

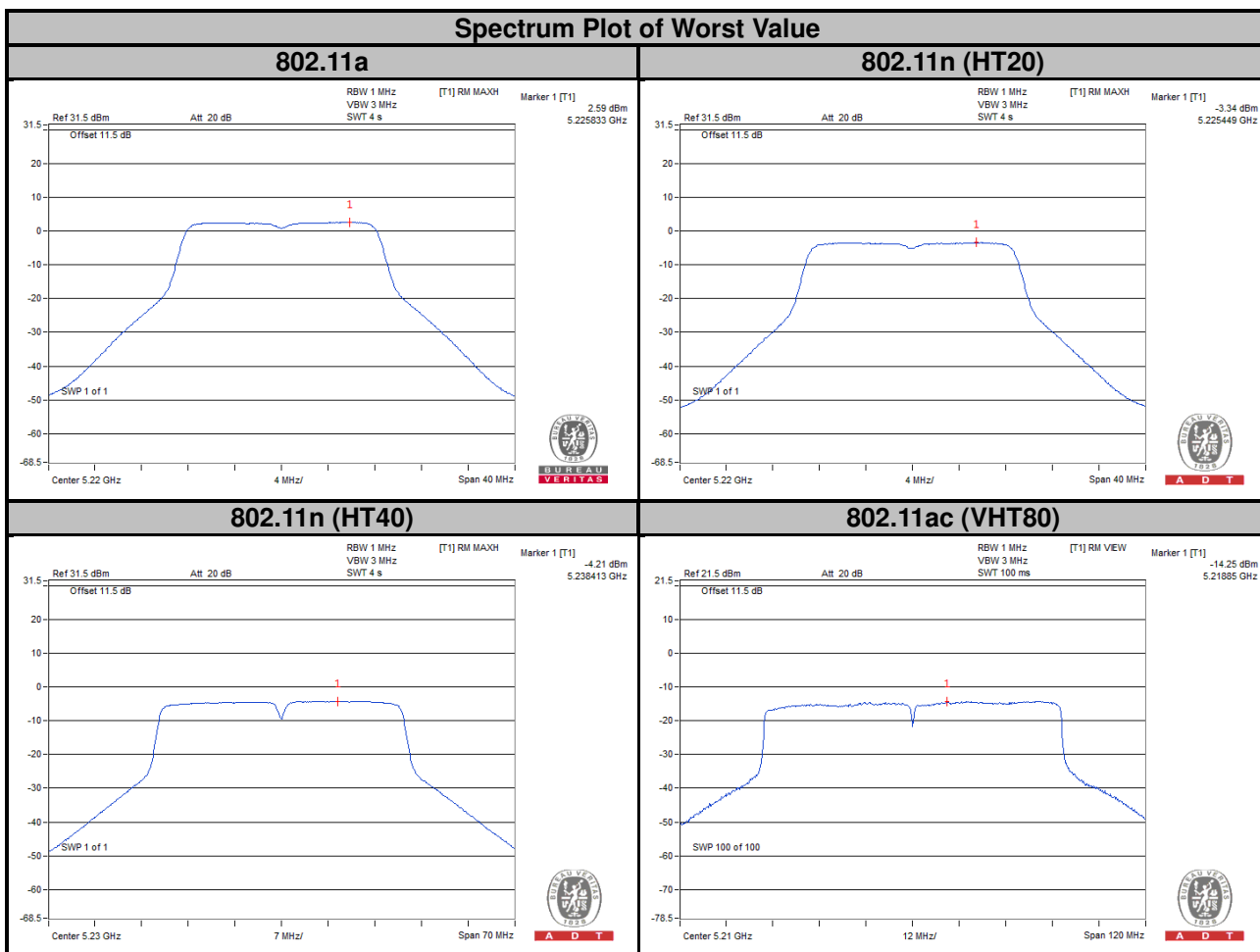

For U-NII-3 Band

802.11a

Channel	Frequency (MHz)	PSD w/o Duty Factor (dBm/500 kHz)	Duty Factor (dB)	PSD with Duty Factor (dBm/500 kHz)	Limit (dBm/500 kHz)	Pass / Fail
149	5745	3.65	0.14	3.79	30	Pass
157	5785	3.64	0.14	3.78	30	Pass
165	5825	3.98	0.14	4.12	30	Pass

Note: Refer to section 3.3 for duty cycle spectrum plot.

802.11n (HT20)

TX Chain	Channel	Frequency (MHz)	PSD (dBm/500 kHz)	10 log (N=3) dB	Duty Factor (dB)	Total PSD with Duty Factor (dBm/500 kHz)	Limit (dBm/500 kHz)	Pass / Fail
0	149	5745	-1.32	4.77	0.15	3.60	26.93	Pass
	157	5785	-0.70	4.77	0.15	4.22	26.93	Pass
	165	5825	-0.78	4.77	0.15	4.14	26.93	Pass
1	149	5745	0.10	4.77	0.15	5.02	26.93	Pass
	157	5785	0.36	4.77	0.15	5.28	26.93	Pass
	165	5825	0.67	4.77	0.15	5.59	26.93	Pass
2	149	5745	-0.73	4.77	0.15	4.19	26.93	Pass
	157	5785	-0.39	4.77	0.15	4.53	26.93	Pass
	165	5825	-0.21	4.77	0.15	4.71	26.93	Pass

Note:

- Method 1 of power density measurement of KDB 662911 is using for calculating total power density. Total power density is summing entire spectra across corresponding frequency bins on the various outputs by computer.
- Directional gain = $10 \log[(10^{G1/20} + 10^{G2/20} + \dots + 10^{GN/20})^2 / N_{ANT}] = 9.07 \text{dBi} > 6 \text{dBi}$, so the power density limit shall be reduced to $30 - (9.07 - 6) = 26.93 \text{ dBm}$.
- Refer to section 3.3 for duty cycle spectrum plot.

802.11n (HT40)

TX Chain	Channel	Frequency (MHz)	PSD (dBm/500 kHz)	10 log (N=3) dB	Duty Factor (dB)	Total PSD with Duty Factor (dBm/500 kHz)	Limit (dBm/500 kHz)	Pass / Fail
0	151	5755	-4.50	4.77	0.55	0.82	26.93	Pass
	159	5795	-4.45	4.77	0.55	0.87	26.93	Pass
1	151	5755	-3.35	4.77	0.55	1.97	26.93	Pass
	159	5795	-2.73	4.77	0.55	2.59	26.93	Pass
2	151	5755	-3.55	4.77	0.55	1.77	26.93	Pass
	159	5795	-3.01	4.77	0.55	2.31	26.93	Pass

Note:

- Method 1 of power density measurement of KDB 662911 is using for calculating total power density. Total power density is summing entire spectra across corresponding frequency bins on the various outputs by computer.
- Directional gain = $10 \log[(10^{G1/20} + 10^{G2/20} + \dots + 10^{GN/20})^2 / N_{ANT}] = 9.07\text{dBi} > 6\text{dBi}$, so the power density limit shall be reduced to $30 - (9.07 - 6) = 26.93 \text{ dBm}$.
- Refer to section 3.3 for duty cycle spectrum plot.

802.11ac (VHT80)

TX Chain	Channel	Frequency (MHz)	PSD (dBm/500 kHz)	10 log (N=3) dB	Duty Factor (dB)	Total PSD with Duty Factor (dBm/500 kHz)	Limit (dBm/500 kHz)	Pass / Fail
0	155	5775	-8.47	4.77	0.91	-2.79	26.93	Pass
1	155	5775	-6.44	4.77	0.91	-0.76	26.93	Pass
2	155	5775	-7.22	4.77	0.91	-1.54	26.93	Pass

Note:

- Method 1 of power density measurement of KDB 662911 is using for calculating total power density. Total power density is summing entire spectra across corresponding frequency bins on the various outputs by computer.
- Directional gain = $10 \log[(10^{G1/20} + 10^{G2/20} + \dots + 10^{GN/20})^2 / N_{ANT}] = 9.07\text{dBi} > 6\text{dBi}$, so the power density limit shall be reduced to $30 - (9.07 - 6) = 26.93 \text{ dBm}$.
- Refer to section 3.3 for duty cycle spectrum plot.

Spectrum Plot of Worst Value

802.11a

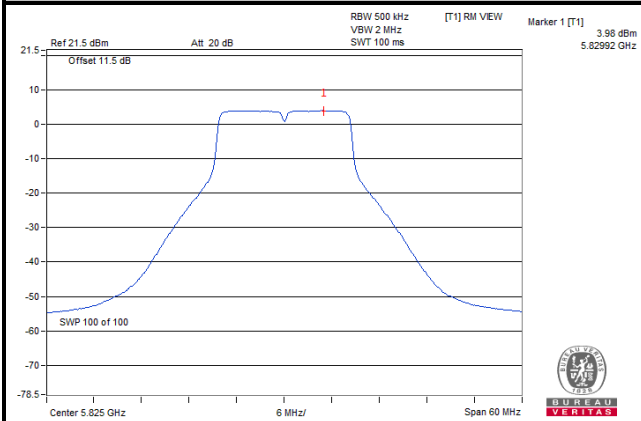

802.11n (HT20)

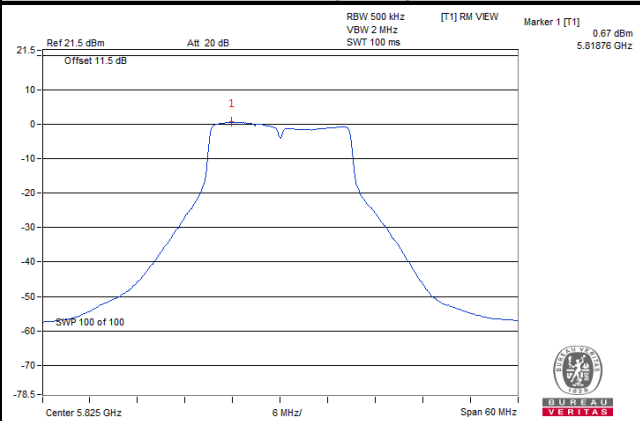

802.11n (HT40)

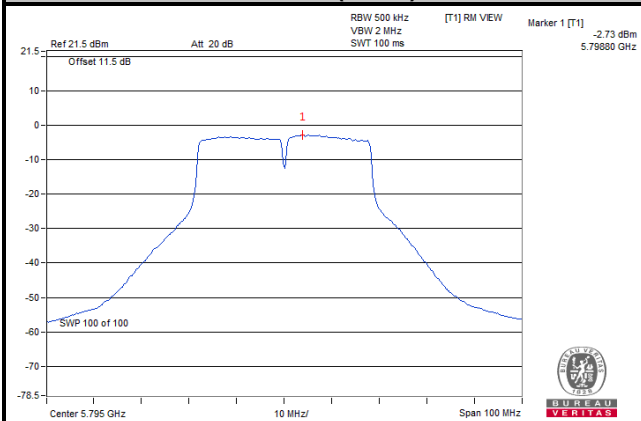

802.11ac (VHT80)

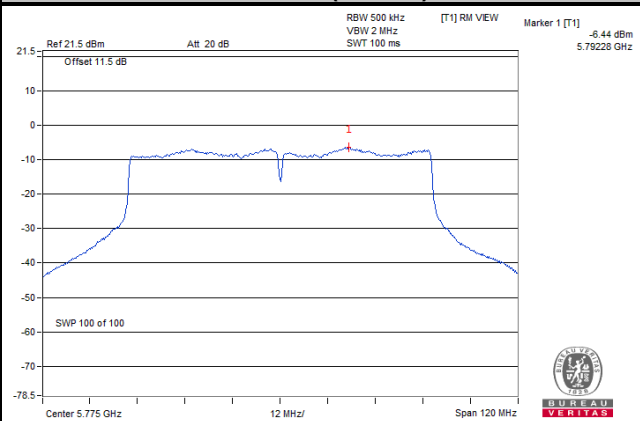

4.6 Frequency Stability

4.6.1 Limit of Frequency Stability Measurement

The frequency of the carrier signal shall be maintained within band of operation.

4.6.2 Test Setup

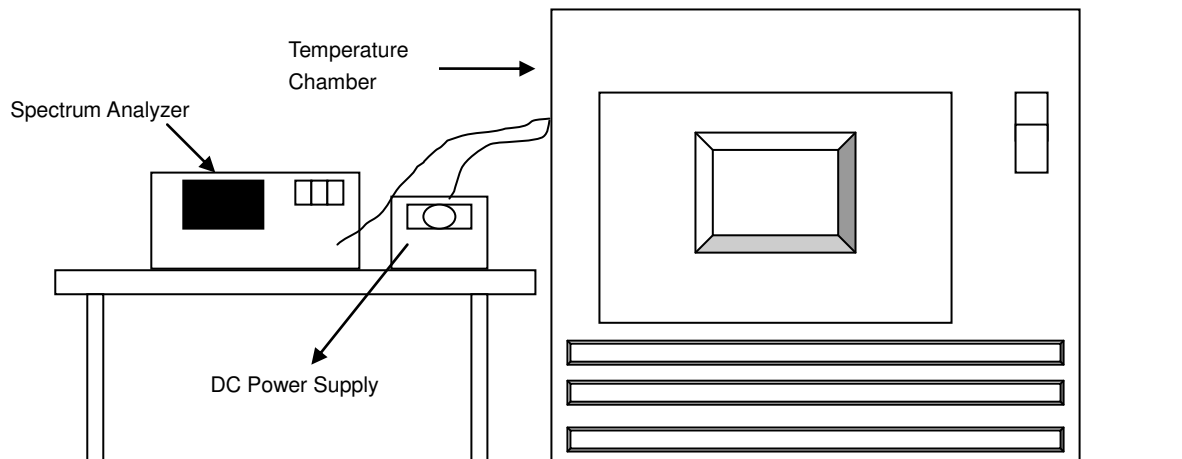

4.6.3 Test Instruments

Refer to section 4.1.3 to get information of above instrument.

4.6.4 Test Procedure

- To ensure emission at the band edge is maintained within the authorized band, those values shall be measured by radiation emissions at upper and lower frequency points, and finally compensated by frequency deviation as procedures below.
- The EUT was operated at the maximum output power, and connected to the spectrum analyzer, which is set to maximum hold function and peak detector. The peak value of the power envelope was measured and noted. The upper and lower frequency points were respectively measured relatively 10 dB lower than the measured peak value.
- The frequency deviation was calculated by adding the upper frequency point and the lower frequency point divided by two. Those detailed values of frequency deviation are provided in table below.

4.6.5 Deviation from Test Standard

No deviation.

4.6.6 EUT Operating Condition

Set the EUT transmit at un-modulation mode to test frequency stability.

4.6.7 Test Results

Frequency Stability Versus Temp.									
Operating Frequency: 5745 MHz									
Temp. (°C)	Power Supply (Vac)	0 Minute		2 Minute		5 Minute		10 Minute	
		Measured Frequency (MHz)	Frequency Drift (ppm)	Measured Frequency (MHz)	Frequency Drift (ppm)	Measured Frequency (MHz)	Frequency Drift (ppm)	Measured Frequency (MHz)	Frequency Drift (ppm)
50	120	5744.9833	-0.00029	5744.9842	-0.00028	5744.9859	-0.00025	5744.9845	-0.00027
40	120	5745.0045	0.00008	5745.0061	0.00011	5745.0093	0.00016	5745.0051	0.00009
30	120	5744.9754	-0.00043	5744.9752	-0.00043	5744.9776	-0.00039	5744.979	-0.00037
20	120	5745.0018	0.00003	5744.9982	-0.00003	5745.0023	0.00004	5745.0026	0.00005
10	120	5744.9779	-0.00038	5744.9774	-0.00039	5744.9743	-0.00045	5744.9736	-0.00046
0	120	5745.0294	0.00051	5745.0278	0.00048	5745.0305	0.00053	5745.0294	0.00051
-10	120	5744.9767	-0.00041	5744.9767	-0.00041	5744.9743	-0.00045	5744.9744	-0.00045
-20	120	5745.0142	0.00025	5745.0163	0.00028	5745.0163	0.00028	5745.0127	0.00022
-30	120	5745.017	0.00030	5745.0187	0.00033	5745.0204	0.00036	5745.0177	0.00031

Frequency Stability Versus Temp.									
Operating Frequency: 5745 MHz									
Temp. (°C)	Power Supply (Vac)	0 Minute		2 Minute		5 Minute		10 Minute	
		Measured Frequency (MHz)	Frequency Drift (ppm)	Measured Frequency (MHz)	Frequency Drift (ppm)	Measured Frequency (MHz)	Frequency Drift (ppm)	Measured Frequency (MHz)	Frequency Drift (ppm)
20	138	5745.0022	0.00004	5744.9991	-0.00002	5745.0016	0.00003	5745.003	0.00005
	120	5745.0018	0.00003	5744.9982	-0.00003	5745.0023	0.00004	5745.0026	0.00005
	102	5745.0015	0.00003	5744.9983	-0.00003	5745.0027	0.00005	5745.0026	0.00005

4.7 6 dB Bandwidth Measurement

4.7.1 Limits of 6 dB Bandwidth Measurement

The minimum of 6 dB Bandwidth Measurement is 0.5 MHz.

4.7.2 Test Setup



4.7.3 Test Instruments

Refer to section 4.1.3 to get information of above instrument.

4.7.4 Test Procedure

MEASUREMENT PROCEDURE REF

- Set resolution bandwidth (RBW) = 100 kHz
- Set the video bandwidth (VBW) $\geq 3 \times$ RBW, Detector = Peak.
- Trace mode = max hold.
- Sweep = auto couple.
- Measure the maximum width of the emission that is constrained by the frequencies associated with the two amplitude points (upper and lower) that are attenuated by 6 dB relative to the maximum level measured in the fundamental emission

4.7.5 Deviation from Test Standard

No deviation.

4.7.6 EUT Operating Condition

The software provided by client to enable the EUT under transmission condition continuously at lowest, middle and highest channel frequencies individually.

4.7.7 Test Results

802.11a

Channel	Frequency (MHz)	6 dB Bandwidth (MHz)	Minimum Limit (MHz)	Pass / Fail
149	5745	16.40	0.5	Pass
157	5785	16.38	0.5	Pass
165	5825	16.38	0.5	Pass

802.11n (HT20)

Channel	Frequency (MHz)	6 dB Bandwidth (MHz)			Minimum Limit (MHz)	Pass / Fail
		Chain 0	Chain 1	Chain 2		
149	5745	17.57	17.61	17.60	0.5	Pass
157	5785	17.62	17.36	17.61	0.5	Pass
165	5825	17.31	17.60	17.57	0.5	Pass

802.11n (HT40)

Channel	Frequency (MHz)	6 dB Bandwidth (MHz)			Minimum Limit (MHz)	Pass / Fail
		Chain 0	Chain 1	Chain 2		
151	5755	36.48	36.07	36.40	0.5	Pass
159	5795	36.40	36.38	36.37	0.5	Pass

802.11ac (VHT80)

Channel	Frequency (MHz)	6 dB Bandwidth (MHz)			Minimum Limit (MHz)	Pass / Fail
		Chain 0	Chain 1	Chain 2		
155	5775	76.46	74.99	75.41	0.5	Pass

Spectrum Plot of Worst Value

802.11a

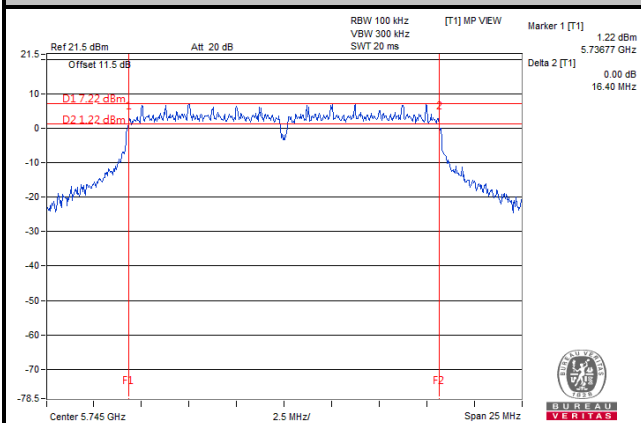

802.11n (HT20)

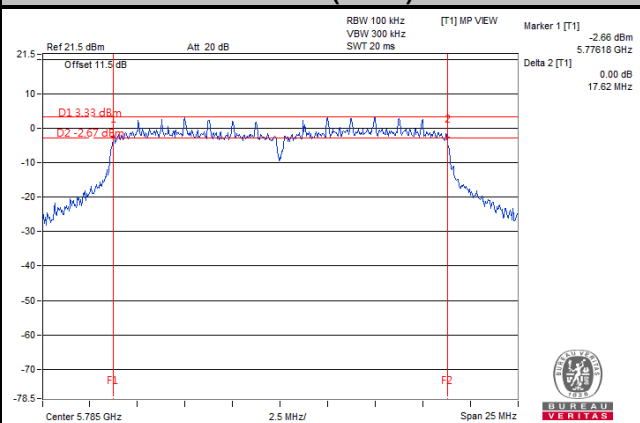

802.11n (HT40)

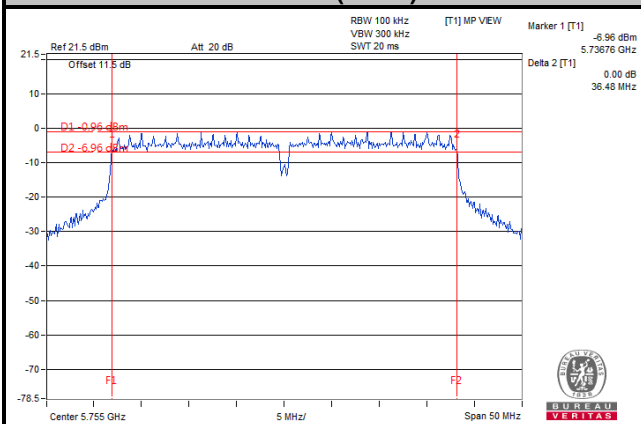

802.11ac (VHT80)

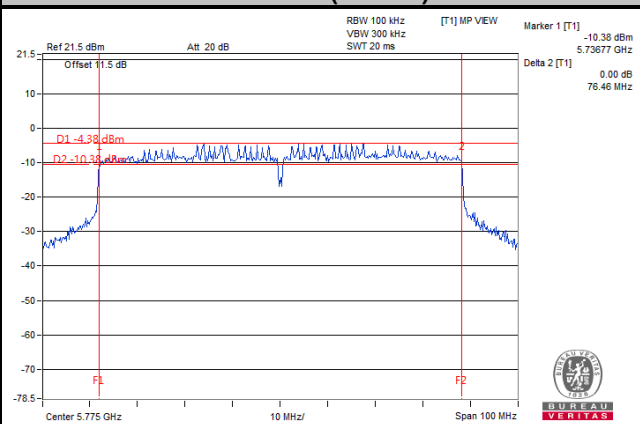

5 Pictures of Test Arrangements

Please refer to the attached file (Test Setup Photo).

Annex A- Radiated Out of Band Emisison (OOBE) Measurement (For U-NII-3 band)

802.11a

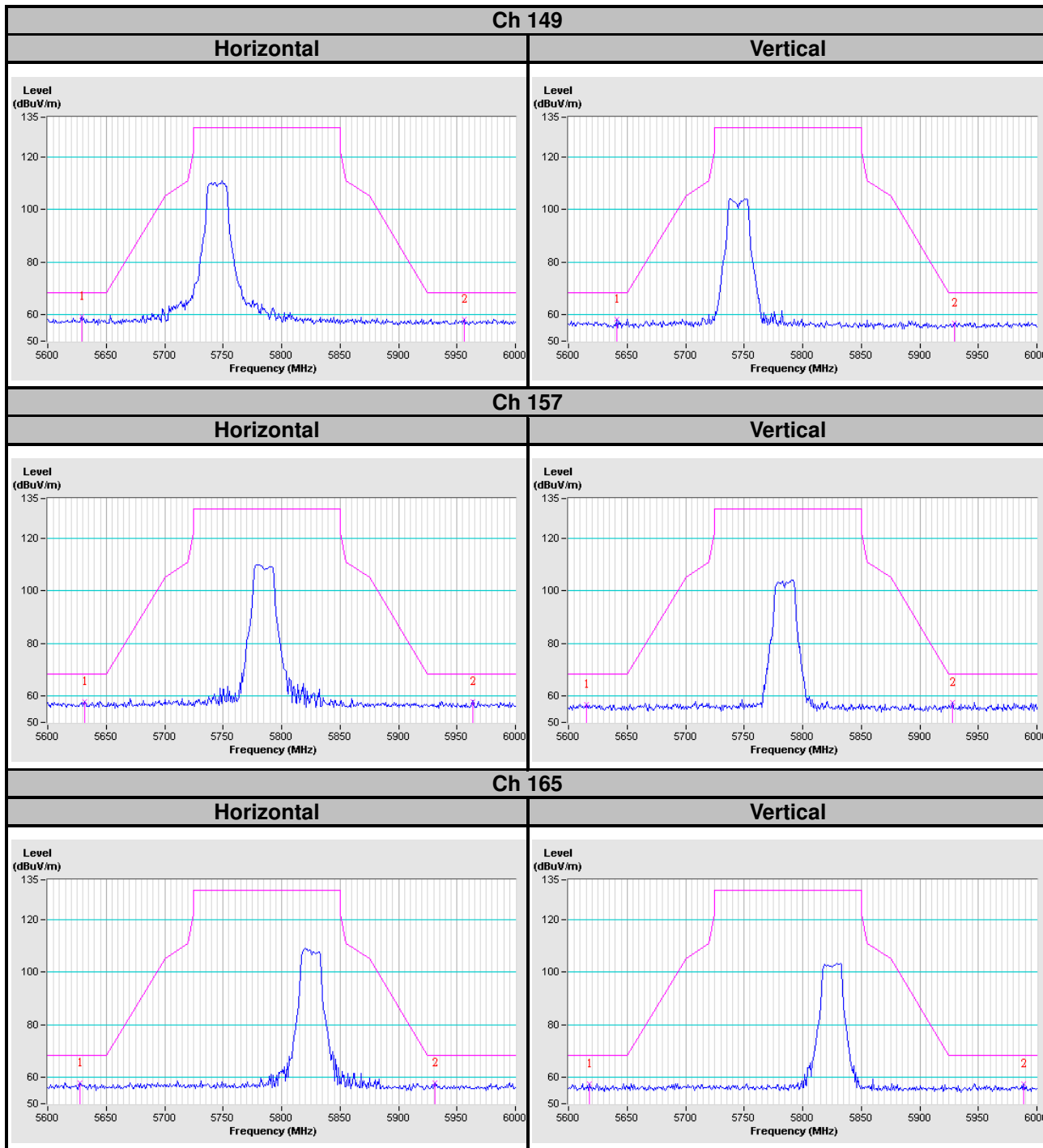

802.11n (HT20)

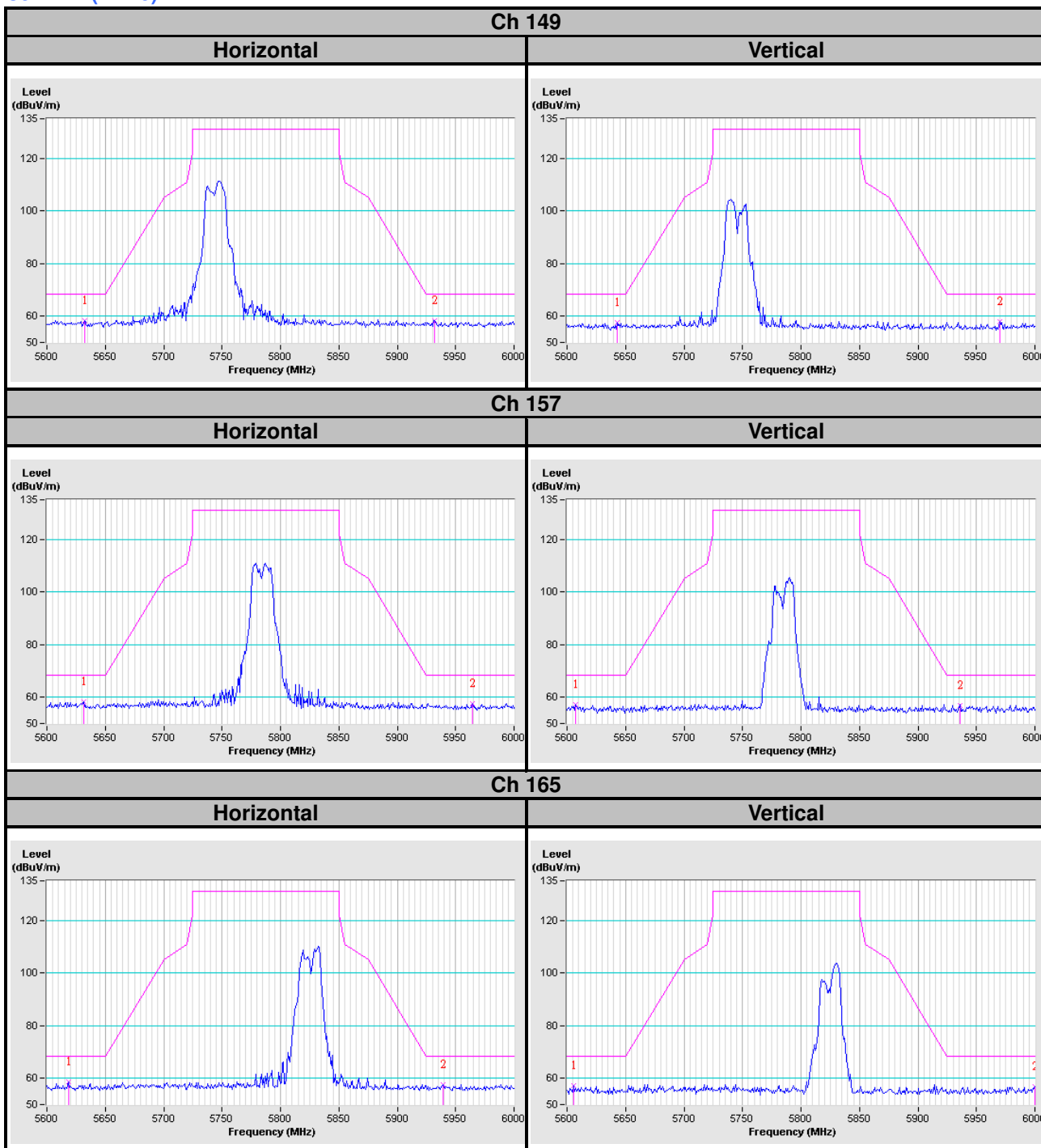

802.11n (HT40)

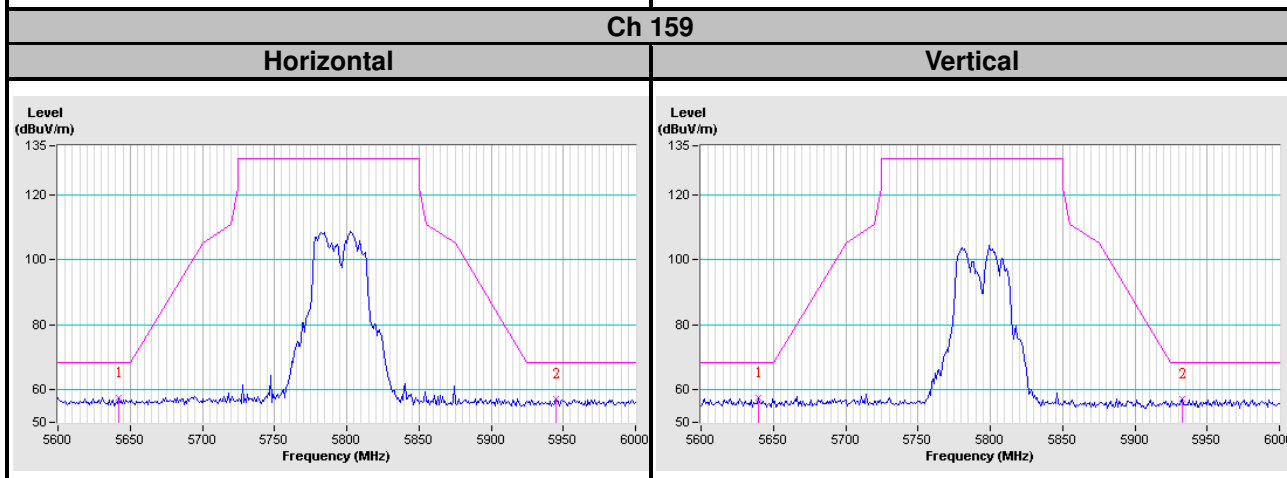
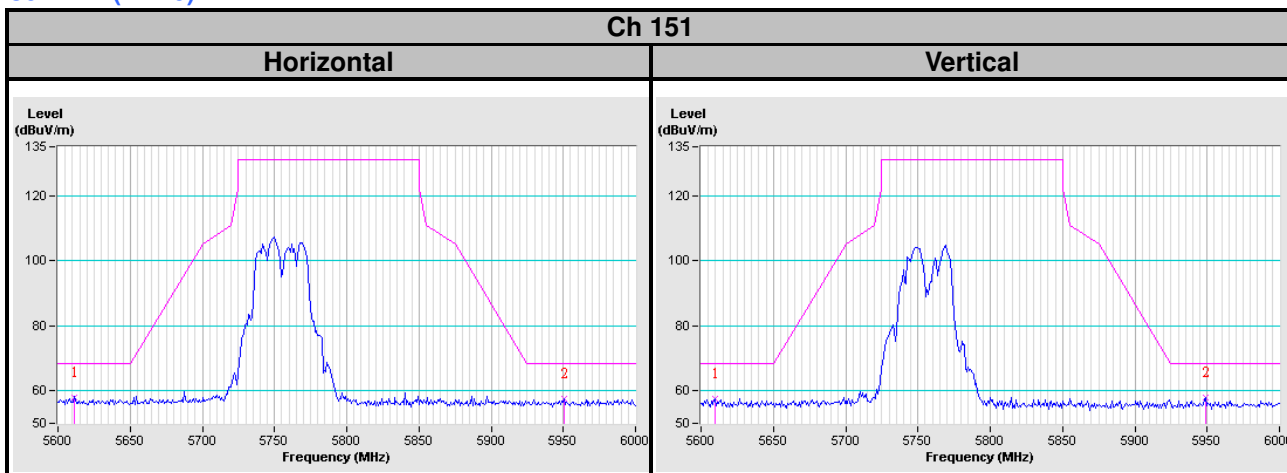

802.11ac (VHT80)

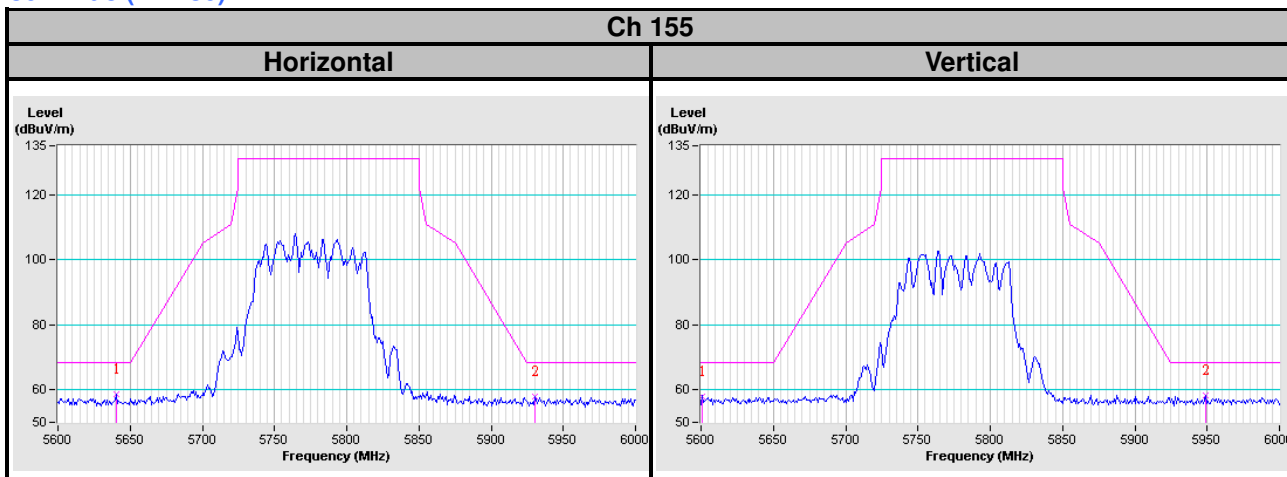

Appendix – Information on the Testing Laboratories

We, Bureau Veritas Consumer Products Services (H.K.) Ltd., Taoyuan Branch, were founded in 1988 to provide our best service in EMC, Radio, Telecom and Safety consultation. Our laboratories are FCC recognized accredited test firms and accredited according to ISO/IEC 17025.

If you have any comments, please feel free to contact us at the following:

Linko EMC/RF Lab

Tel: 886-2-26052180

Fax: 886-2-26051924

Hsin Chu EMC/RF/Telecom Lab

Tel: 886-3-6668565

Fax: 886-3-6668323

Hwa Ya EMC/RF/Safety

Tel: 886-3-3183232

Fax: 886-3-3270892

Email: service.adt@tw.bureauveritas.com

Web Site: www.bureauveritas-adt.com

The address and road map of all our labs can be found in our web site also.

--- END ---