

Manual

Product Instruction

For your safety, please read this manual carefully before using this product.

First: In order to prevent injury or damage to property, please strictly comply with the following guidelines:

- A) Warning! It may cause serious injuries or even casualties. People should consult the doctor before using implantable medical devices (such as using pacemaker). Please install your equipment 50 centimeters away from this product because it may influence the operation of implantable medical device.
- B) Attention! It may cause fever, fire and electric shock.
 - 1) Do not put the product in water or other liquids, avoid water into the product;
 - 2) Do not touch the AC adapter with wet hands to ensure the safety and integrity of the adapter
 - 3) Do not let dust accumulate on this product and adapter
 - 4) Do not use this product under ambient -10 degree C and over 40 degree C.;
 - 5) Do not use it in the places of direct sunlight or high temperature;
 - 6) Do not use the product where is slippery to avoid break down.
 - 7) Do not charge too close to magnetic sheets, magnetic recording media and precision instruments
 - 8) Do not decompose and transform this product
 - 9) Do not put anything between the wireless charging transmitter board and the charging mobile phone
 - 10) When using plugs and other connections, do not exceed the rated value
 - 11) When using, please make sure that you have connected the AC adapter correctly to avoid any damage. Unplug AC adapter from plug when stopping using it.
 - 12) Do not use travel converters
 - 13) Do not let your children use it until they know how to use it.

Second: Charging method of wireless charging

The product can be embedded in office furniture and sofa armrests.

Diagram for using and installing:

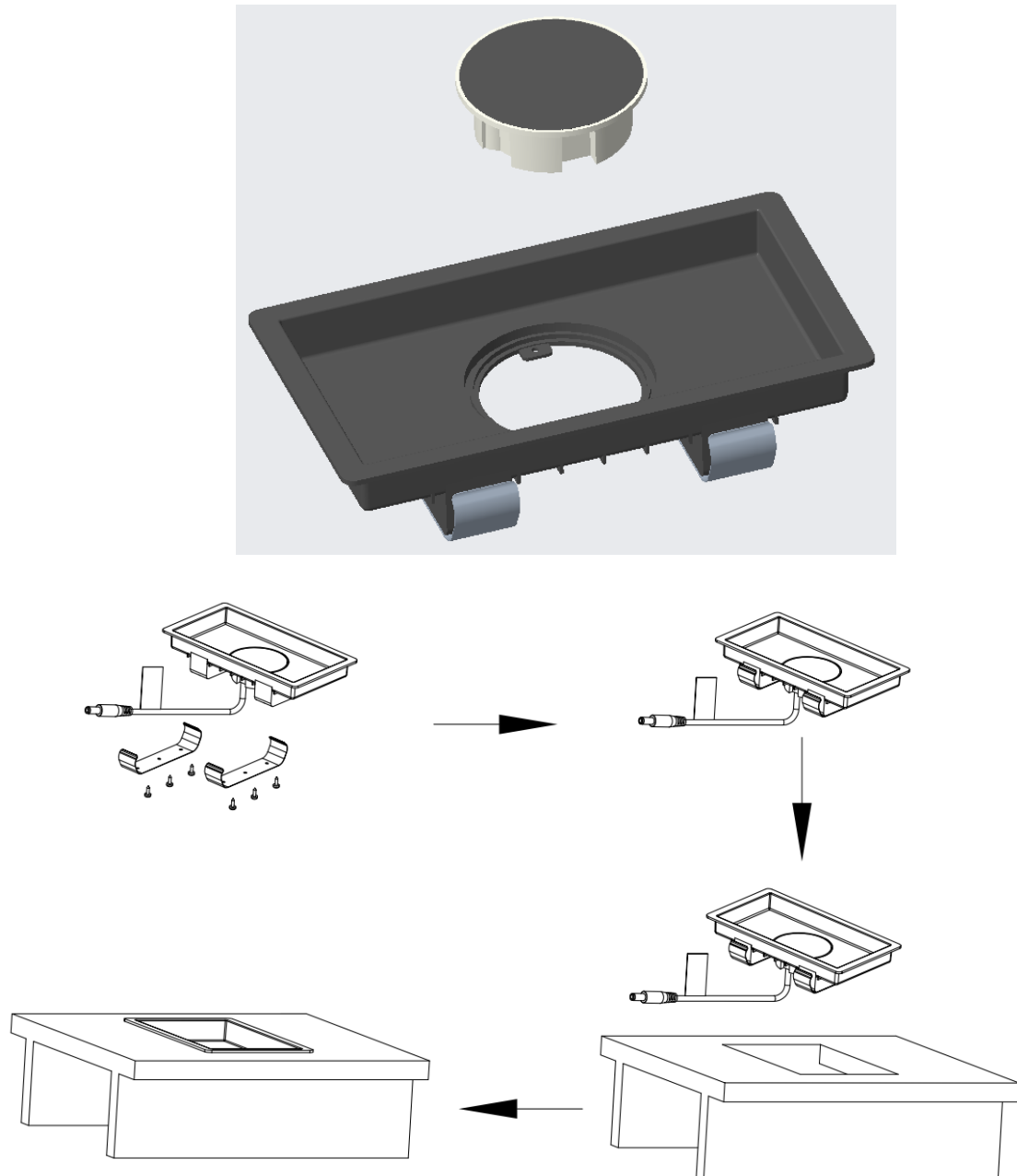

- 1) Connect the product to an adapter that with the characteristics of " 40 degree C max. and altitude of operation at 2000m whose output meets ES1, and rated "5 Vdc 2A" or "9 Vdc 1.65A" or "12 Vdc 1.2A"only and marked LPS", blue and green lights will alternately flicker when power is turned on;
- 2) If the wireless charging product detects that there is no equipment to be charged in the charging area, the product will be on standby.

- 3) Place the equipment (mobile phone) that needs to be charged in the charging area of the product, the green light is on; then the blue light will be on when it enters charging condition.
- 4) After charging, the product is standby, the blue light is on, then take it away.
- 5) If there is a metal thing in the charging area (the center of the coil), blue and green light flicker alternately and will disconnect wireless charging to protect equipment

Third: Product parameter:

P/N: WCT BR 05

Product name: Embedded wireless charger

Dimension: outer diameter is 69.7mm, inner diameter is 54.3mm, and height is 23mm

Weight: 140 g

Main function: Wireless charging launcher

Product application: All wireless charging devices under Qi standard

Charging type: One-to-one charging in corresponding area

Input voltage: DC 2A/5V, DC 1.65A/9V, DC 1.2A/12V ;

Launch distance: 2-6mm

Charging power: Input : 5V/2A, Output: 5W(Max) ;

Input : 9V/1.65A, Output: 10W(Max) ;

Input : 12V/1.2A, Output: 10W(Max) ;

Conversion efficiency : > 70%

Charging way: Induction mode

Working frequency: 110.5—148KHz

FCC Statement

This device complies with Part 15 of the FCC Rules. Operation is subject to the following two conditions:(1) This device may not cause harmful interference. (2)This device must accept any interference received, including interference that may cause undesired operation.

WARNING: Changes or modifications not expressly approved by the party responsible for compliance could void the user's authority to operate the equipment.

Note: This equipment has been tested and found to comply with the limits for a class B digital device, pursuant to Part 15 of the FCC Rules. These limits are designed to provide reasonable protection against harmful interference in a residential installation. This equipment generates uses and can radiate radio frequency energy and, if not installed and used in accordance with the instructions, may cause harmful interference to radio communications. However, there is no guarantee that interference will not occur in a particular installation. if this equipment does cause harmful interference to radio or television reception, which can be determined by turning the equipment off and on, the user is encouraged to try to correct the interference by one or more of the following measures:

- Reorient or relocate the receiving antenna.
- Increase the separation between the equipment and receiver.
- Connect the equipment into an outlet on a circuit different from that to which the receiver is connected.
- Consult the dealer or an experienced radio/TV technician for help.

FCC Radiation Exposure Statement

This equipment complied with FCC radiation exposure limits set forth for an uncontrolled environment. This equipment should be installed and operated with a minimum distance of 20 cm between the device and your body.