

名称/TYPE : A11 发射线圈 (A11 Transmitter coil)50MM

产品型号/Model NO. : ni=6.3uH ±10%

一、 线圈工艺/Winding Procese:

NO	绕组/ Winding	线规/ Wire	匝数/ Turns	绕线方向/ Winding direction	备注 /Note
1	N1	2UEW-B-0.08*105P	10TS	CCW	
2					

二. 电气性能/FEATURES:

1.测试条件 (Test conditions) : 25°C,65%RH@100KHz/1V

1.1 电感量 (Inductance)

1.11 L0A (单独线圈) =3.8uH±20% (Individual coil)

1.12 L0A(线圈+磁片)=6.5uH±10% (Coil + disk)

1.2 Q 值=90MIN

1.3 直流电阻 (DCR) : 45mΩ MAX

1.4 工作温度(Operating Temperature): -25°C~85°C

2.测试仪器(Test instrument): L: 创达 1068+1310;

DCR: 502BC;

SIZE: Callipers

3.材料清单 (Bill of materials)

NO	项目/Items	材料
1	WIRE	φ 0.08*105p 2UEW-1.15mm
2	FERRITE	50*5.3*1.0, L-shaped slot, PC95
3	GLUE	白胶(White glue)
4	SOLDER	XCD-907B

5	Adhesive	双面背胶 (Double-sided gum)
6	High temperature adhesive	8MM 高温胶带(8MM high temperature tape)

三. 电路图/CIRCUIT DIAGRAM

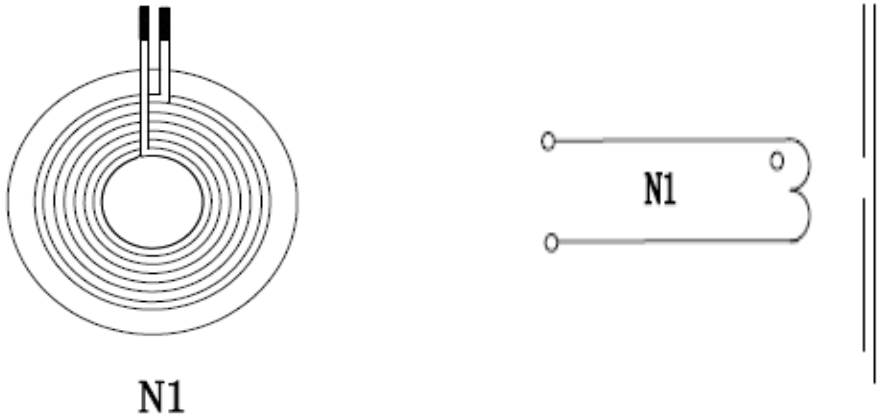

四. 外形图/OUTSIDEDIAGRA

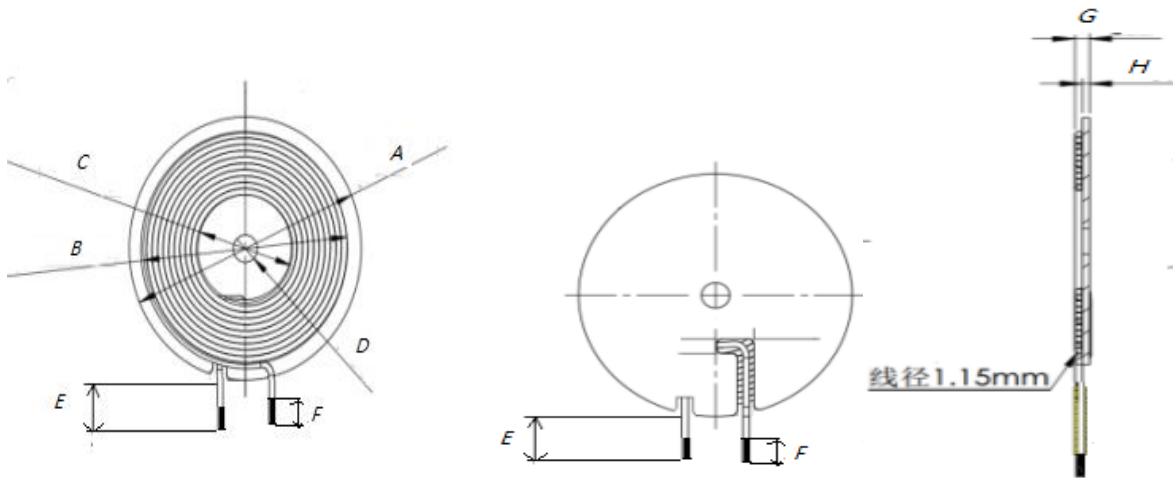

注：线圈出线位置缠绕 8MM (ref) 高温胶纸，线径 1.15mm。 (Coil exit position wound 8MM (ref) high temperature adhesive paper, wire diameter 1.15mm)

标准	A	B	C	D	E	F	G	
STD	50±0.5	42.5±1	20.5±0.5	5±0.5	50±1	3±1	2.8Max	

单位： MM