



GE Healthcare  
3000 North Grandview Blvd  
Waukesha, Wisconsin 53188

May 25<sup>th</sup>, 2011

Chief, Authorizations Branch  
Federal Communications Commission  
7435 Oakland Mills Road  
Columbia, MD 21046

Modular Approval Request Letter  
FCC ID: YYJ-5406102

To Whom It may Concern:

GE Medical Systems, LLC would like to have your authorization for singular modular certification of FCC ID YYJ-5406102. The statements in the table below explain our compliance with the eight requirements listed in 47 CFR 15.212.

47 CFR 15.212 Requirement	Statement
i	All shielding of RF emissions are mitigated by means of multilayer circuit board design that makes effective use of embedded signal layers between grounding layers for non-RF signals.
ii	Buffered data inputs are implemented within the RTU7105 chip implementation.
iii	Power regulation for the GE Healthcare 5406102 is implemented both at the circuit board level as well within the RTU7105 chip per the architecture block diagram shown below:



GE Healthcare  
 3000 North Grandview Blvd  
 Waukesha, Wisconsin 53188

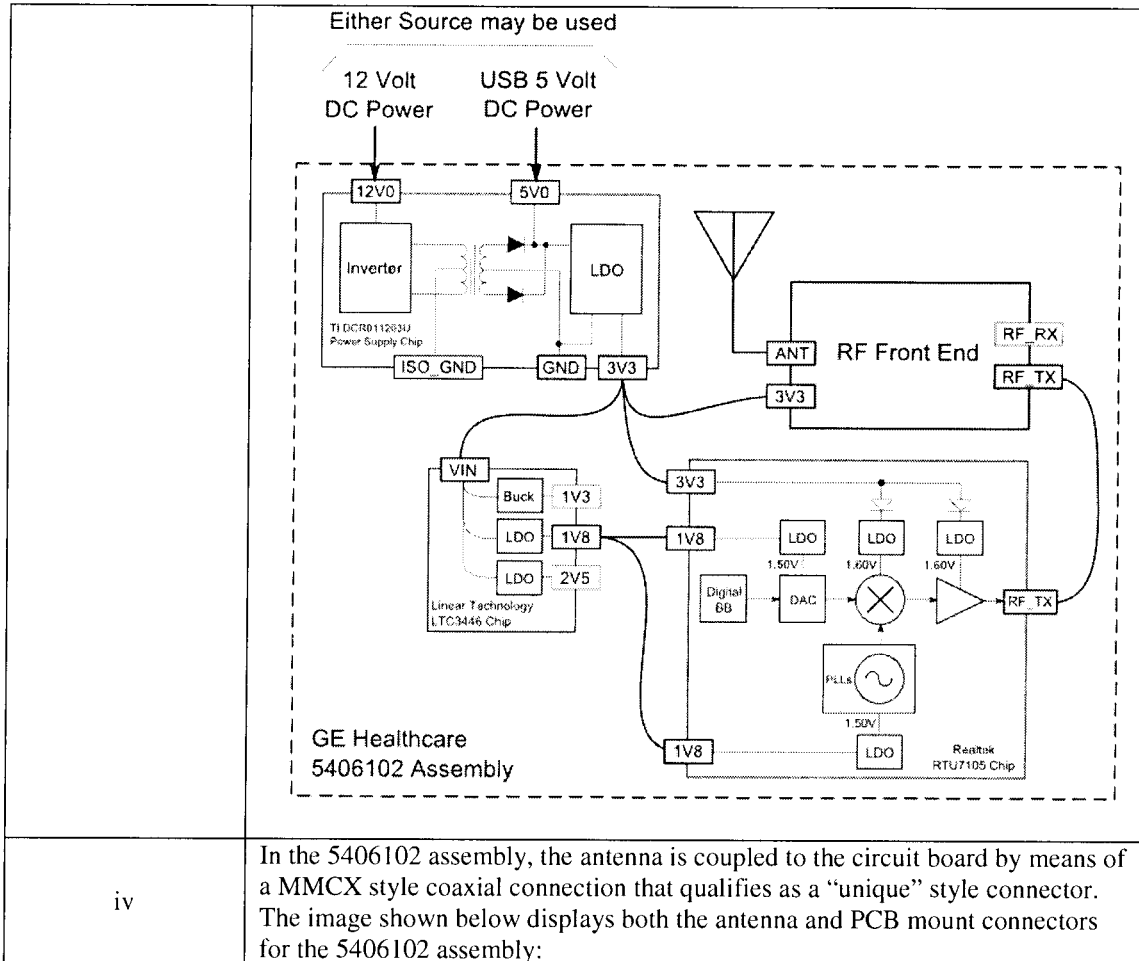

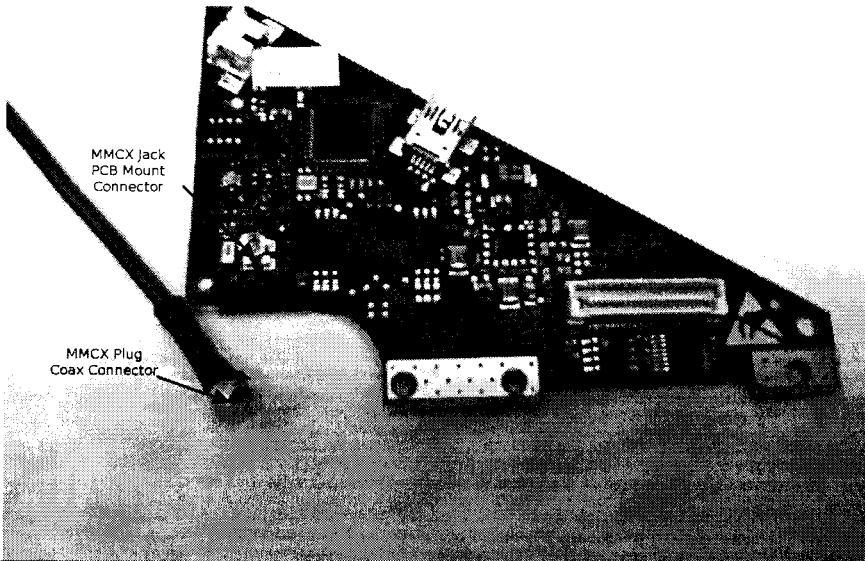
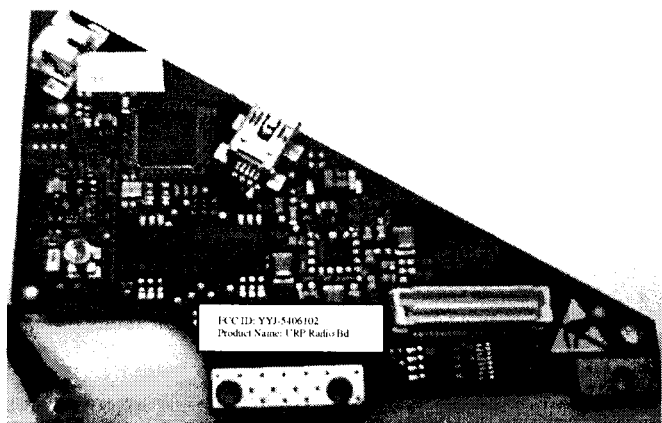

GE Healthcare  
3000 North Grandview Blvd  
Waukesha, Wisconsin 53188

	 <p>MMCX Jack PCB Mount Connector</p> <p>MMCX Plug Coax Connector</p>
v	The 5406102 assembly has been tested and verified in the stand alone configuration as detailed in the accompanying test report.
vi	The 5406102 assembly shall be labeled by means of a permanent silk screen graphic:  <p>FCC ID: YYJ5406102 Product Name: CRP Radio Id</p>
vii	The accompanying test report details all information regarding compliance with 47 CFR part 15 subsection F.
viii	The 5406102 assembly complies with Maximum Permissible Exposure requirements and its calculation as detailed in the accompanying test report.



GE Healthcare  
3000 North Grandview Blvd  
Waukesha, Wisconsin 53188

Sincerely,

A handwritten signature in black ink that reads "John L. Schmidt". The signature is written in a cursive style and includes a long horizontal flourish extending to the right.

**John L. Schmidt**  
Regulatory Affairs Lead – X-Ray  
GE Medical Systems, LLC  
Phone: 262-548-4964  
Email: [john.L.schmidt@med.ge.com](mailto:john.L.schmidt@med.ge.com)