

Poseidon Class A AIS Transceiver

Installation and Operation Manual

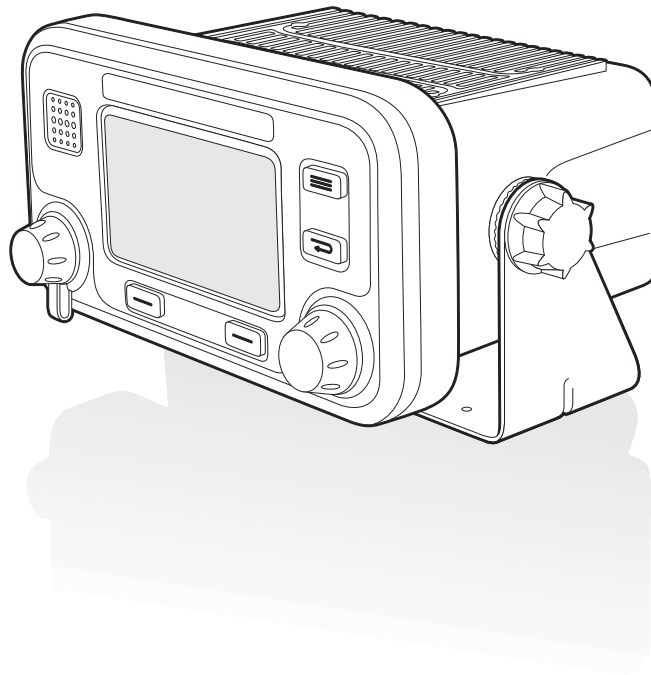

201-0009 Revision 0.4

Thank you for purchasing this AIS Class A transceiver.

This product has been engineered to offer you the highest level of performance and durability and we hope that it will provide many years of reliable service. We constantly strive to achieve the highest possible quality standards, should you encounter any problems with this product, please contact your dealer who will be pleased to offer any assistance you require.

Contents

1	Notices	7
1.1	Safety warnings	7
1.2	General notices	7
1.3	Revision information	8
2	Introduction	9
2.1	About AIS	9
2.2	Static and dynamic vessel data	10
2.3	AIS operation licensing	10
3	Operation	11
3.1	Display and controls	11
3.2	Turning the transceiver on	12
3.3	Display layout	12
3.4	Main operating screens	13
3.5	Target list	14
3.6	Own vessel and voyage data	15
3.7	Own dynamic data	15
3.8	Received messages	16
3.9	Alarms screen	16
3.10	Target plot screen	17
3.11	Working with AIS text and Safety Related Messages (SRMs)	18
3.12	Handling alarms	19
3.13	Entering text	20
3.14	Disabling the display	20
3.15	Long range messages	21
3.16	Passwords and security	23
3.17	The configuration menu	23
3.18	Inland AIS	29
4	Installation	31
4.1	What's in the box?	32
4.2	Preparing for installation	33
4.3	Installation procedures	33
4.4	Connecting the equipment	39
4.5	Configuring the Poseidon transceiver	45
4.6	Changing the password	49
4.7	Confirming correct operation	49
4.8	Regional area settings	49
4.9	Inland AIS	51
5	Technical Specifications	55
5.1	Applicable equipment standards	55
5.2	Physical	55
5.3	Environmental	55
5.4	Electrical	55

5.5	Display and user interface	56
5.6	Internal GPS	56
5.7	TDMA transmitter	56
5.8	TDMA receivers	56
5.9	DSC receiver.....	57
5.10	RF connections.....	57
5.11	Data interfaces.....	57
5.12	Power and data connector information	58
6	Technical reference	59
6.1	Interface sentences.....	59
6.2	Transmission intervals	60
6.3	Sensor data input port.....	60
6.4	Bi-directional data ports	61
6.5	Output drive capability of bi-directional ports	61
6.6	DGPS port.....	61
6.7	RS232 port.....	61
6.8	Input data sentence formats	61
6.9	Output data sentence formats.....	70
7	Drawings	74
7.1	AIS transceiver overall dimensions.....	74
7.2	Junction box overall dimensions	74
7.3	Dash mount bracket fixing holes (drill drawing) (not to scale)	75
7.4	GPS antenna drawing (not to scale).....	75
8	Annex A - ERI Ship types.....	76
9	Installation record	79
10	Warranty	83

List of figures

Figure 1	The AIS network	9
Figure 2	Transceiver front panel	11
Figure 3	Power on display sequence.....	12
Figure 4	Display layout	12
Figure 5	Selection of main operating screen	14
Figure 6	Target list screen and vessel details view	14
Figure 7	Own vessel and voyage data screen.....	15
Figure 8	Own dynamic data screen	16
Figure 9	Received messages screen.....	16
Figure 10	Message details view.....	16
Figure 11	Alarms screen.....	17
Figure 12	Alarm details view.....	17
Figure 13	Target plot screen.....	17
Figure 14	Target plot symbols	18
Figure 15	Safety Related Message notification	18
Figure 16	Message composition	19
Figure 17	Alarm notification screen	20
Figure 18	Text entry.....	21
Figure 19	Long range interrogation notification; automatic response mode enabled	22
Figure 20	Long range interrogation notification; manual response mode enabled	22
Figure 21	Long range message list and details views	22
Figure 22	Password entry screen	23
Figure 23	Main menu structure	24
Figure 24	Main menu screen	25
Figure 25	The voyage data menu	25
Figure 26	The messages menu	26
Figure 27	The user settings menu	26
Figure 28	The installation menu.....	27
Figure 29	The maintenance menu	27
Figure 30	Diagnostics menu	29
Figure 31	Typical AIS transceiver connection.....	31
Figure 32	What's in the box	32
Figure 33	AIS transceiver dimensions	34
Figure 34	Mounting the AIS transceiver.....	34
Figure 35	Panel mounting the AIS transceiver	35
Figure 36	Junction box dimensions	36
Figure 37	Mounting the junction box.....	36
Figure 38	GPS antenna location.....	37
Figure 39	GPS antenna connection.....	37
Figure 40	VHF antenna installation.....	38
Figure 41	VHF antenna connection	39
Figure 42	Connecting the junction box to the transceiver.....	39
Figure 43	Junction box connections	41
Figure 44	Example connection to external display equipment.....	43
Figure 45	Line termination options.....	43
Figure 46	Power connection	44
Figure 47	PC data (RS232) connection	45
Figure 48	Vessel dimensions measurement.....	46
Figure 49	Regional areas list screen	49
Figure 50	Regional area editing screen.....	50
Figure 51	Regional area settings confirmation screen.....	50
Figure 52	Blue sign switch connection.....	53
Figure 53	Input port schematic	60
Figure 54	Data output port schematic.....	61

1 Notices



When reading this manual please pay particular attention to warnings marked with the warning triangle symbol shown on the left. These are important messages for safety, installation and usage of the transceiver.

1.1 Safety warnings



This equipment must be installed in accordance with the instructions provided in this manual. Failure to do so will seriously affect its performance and reliability. It is strongly recommended that a trained technician installs and configures this product.



This equipment is intended as an aid to navigation and is not a replacement for proper navigational judgement. Information provided by the equipment must not be relied upon as accurate. User decisions based upon information provided by the equipment are done so entirely at the users own risk.



Do not install this equipment in a flammable atmosphere such as in an engine room or near to fuel tanks.



Do no attempt to service this equipment as doing so may cause fire, electric shock or malfunction and will invalidate the warranty. If any malfunctions are detected contact your supplier or service agent.



Do not install the transceiver where rain or water may leak onto the equipment. This product has been designed for installation and use in an environment protected from moisture.



NOT ALL SHIPS CARRY AIS. The Officer of the Watch (OOW) should always be aware that other ships and, in particular, leisure craft, fishing vessels and warships may not be fitted with AIS. Any AIS equipment fitted on other ships as a mandatory carriage requirement may also be off based on the Master's professional judgement.

1.2 General notices

1.2.1 Position source

All marine Automatic Identification System (AIS) transceivers utilise a satellite based location system such as the Global Positioning Satellite (GPS) network.

The accuracy of a GPS position fix is variable and affected by factors such as the antenna positioning, how many satellites are used to determine a position and for how long satellite information has been received.

The general term for satellite based location systems is Global Navigation Satellite System or GNSS. This manual refers to either GNSS or GPS depending on context.

1.2.2 Compass safe distance

The compass safe distance of this transceiver is 0.3m or greater for a 0.3° deviation.

1.2.3 Product category

This product is categorised as 'protected' in accordance with the definitions provided in IEC 60945.

1.2.4 Disposal of the transceiver and packaging

Please dispose of this AIS transceiver in accordance with the European WEEE Directive or with the applicable local regulations for disposal of electrical equipment. Every effort has been made to ensure the packaging for the transceiver is recyclable. Please dispose of the packaging in an environmentally friendly manner.

1.2.5 Accuracy of this manual

This manual is intended as a guide to the installation, setup and use of this product. Every effort has been made to ensure the accuracy of this manual, however due to continuous product development this manual may not be accurate in all respects, therefore no guarantee is offered. If you are in any doubt about any aspect of this product, please contact your dealer.

1.2.6 Marine Equipment Directive

The SRT Marine Technology Poseidon transceiver complies with international standards and is type approved in accordance with the European Marine Equipment Directive. The EU Declaration of Conformity is provided at the rear of this manual and lists the relevant approval standards.

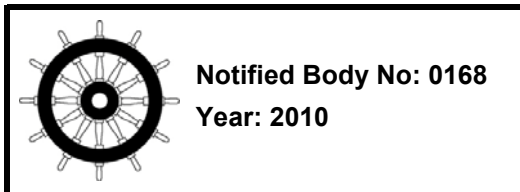

1.3 Revision information

This manual applies to the following transceiver hardware and software versions:

- Transceiver software version 050200.05.00.00
- Display software version 050400.02.00.00
- Hardware version 4.0

2 Introduction

2.1 About AIS

The marine Automatic Identification System (AIS) is a location and vessel information reporting system. It allows vessels equipped with AIS to automatically and dynamically share and regularly update their position, speed, course and other information such as vessel identity with similarly equipped vessels. Position is derived from the Global Positioning System (GPS) and communication between vessels is by Very High Frequency (VHF) digital transmissions.

There are a number of types of AIS device as follows:

- **Class A transceivers.** These are designed to be fitted to commercial vessels such as cargo ships and large passenger vessels. Class A transceivers transmit at a higher VHF signal power than class B transceivers and therefore can be received by more distant vessels, and also transmit more frequently. Class A transceivers are mandatory on all vessels over 300 gross tonnes on international voyages and certain types of passenger vessels under the SOLAS mandate.
- **Class B transceivers.** Similar to Class A transceivers in many ways, but are normally lower cost due to the less stringent performance requirements. Class B transceivers transmit at a lower power and at a lower reporting rate than Class A transceivers.
- **AIS base stations.** AIS base stations are used by Vessel Traffic Systems to monitor and control the transmissions of AIS transceivers.
- **Aids to Navigation (AtoN) transceivers.** AtoNs are transceivers mounted on buoys or other hazards to shipping which transmit details of their location to the surrounding vessels.
- **AIS receivers.** AIS receivers will generally receive transmissions from Class A transceivers, Class B transceivers, AtoNs and AIS base stations but do not transmit any information about the vessel on which they are installed.

The Poseidon transceiver is a Class A transceiver.

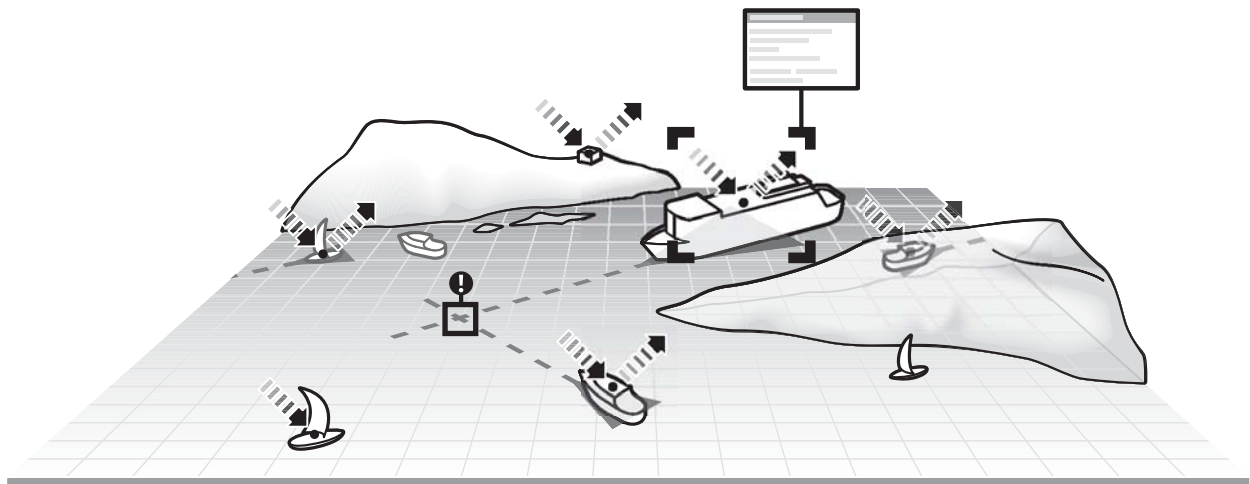

Figure 1 The AIS network

2.2 Static and dynamic vessel data

Information transmitted by an AIS transceiver is in two categories: static and dynamic data.

The vessel's dynamic data which includes location, speed over ground (SOG) and course over ground (COG) is calculated automatically using the internal GPS receiver.

Static data is information about the vessel which must be programmed into the AIS transceiver. This includes:

- Maritime Mobile Service Identity (MMSI)
- Vessel name
- Vessel call sign (if available)
- Vessel type
- Vessel dimensions

2.3 AIS operation licensing

In most countries the operation of an AIS transceiver is included under the vessel's marine VHF licence provisions. The vessel on to which the AIS transceiver is to be installed must therefore possess a current VHF radiotelephone licence which lists the AIS system, vessel Call Sign and MMSI number. Please contact the relevant authority in your country for further information regarding ship's radio licensing requirements.

3 Operation

This section assumes that the Poseidon transceiver has been installed in accordance with the instructions provided in the Installation section of this manual.

Please read the warning notices at the front of this manual before operating the AIS transceiver.

3.1 Display and controls

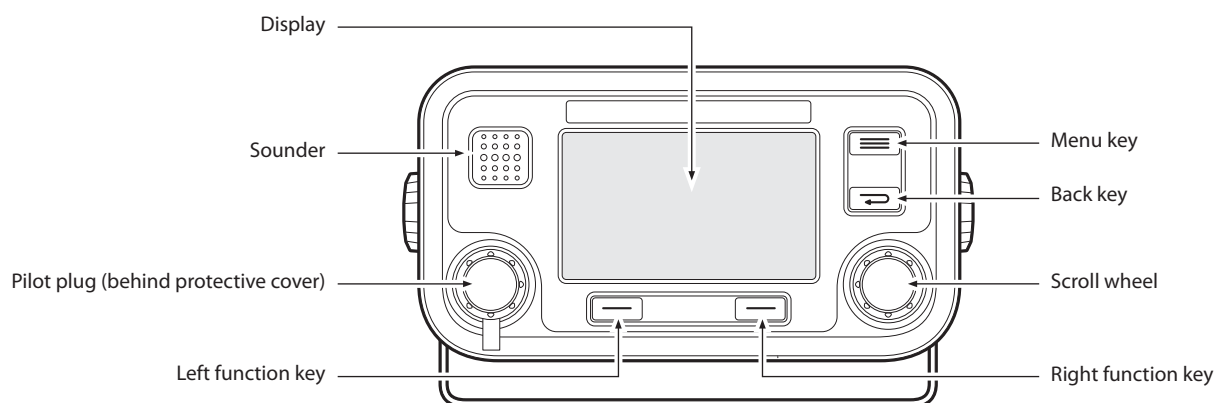

Figure 2 Transceiver front panel

The front panel of the transceiver is shown in Figure 2 with each control marked.

Menu key

This key provides access to the transceiver set up and configuration menu from any operating screen. Holding down the Menu key for more than 3 seconds will disable the display although the transceiver will continue to operate normally. Pressing any key will activate the screen.

Back key

This key cancels the current operation, moves to the previous menu level or acts as a backspace key depending on the operation being carried out.

Scroll wheel

The scroll wheel is used to select information presented on the display, select menu items and edit text and numeric information shown on the screen. The scroll wheel can also be pressed to confirm data entry.

Right and left function keys

The function of these keys is shown in the display area directly above each key. The function depends on the operation being carried out.

Sounder

The Sounder provides an audible 'beep' when a key is pressed. Key beeps can be activated or deactivated via the User Settings menu.

Pilot Plug

The pilot plug provides an AIS connection for pilots using the IMO standard pilot plug connector.

Display

The display shows essential AIS operating information and allows for configuration of the transceiver. It is recommended that the transceiver is connected to a compatible Electronic Chart Display System (ECDIS) for monitoring of AIS vessels during navigation.

3.2 Turning the transceiver on

The Poseidon transceiver does not have a power switch and is designed to be permanently powered. When power is first applied the display will show a splash screen followed by software version information. Each screen is shown for 5 seconds before the main operating screen is shown.

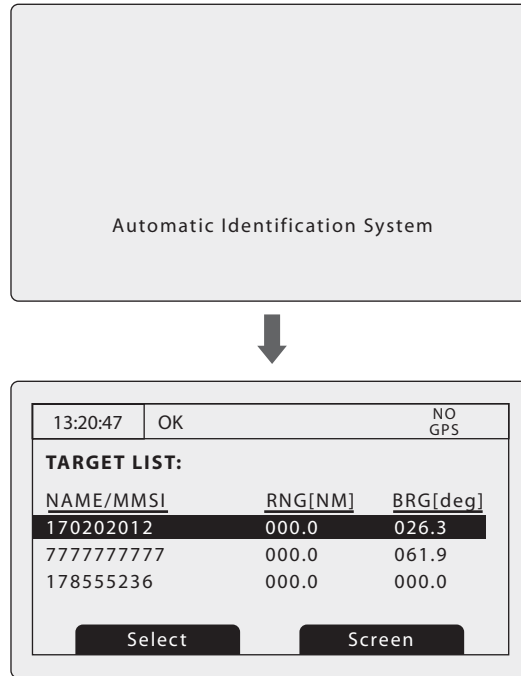

Figure 3 Power on display sequence

3.3 Display layout

The display layout is shown in Figure 4. All operating screens show the time, status bar, scroll indicators and relevant function keys. The time displayed is UTC time.

When no UTC time is available from the internal GNSS module the time display will show --:--:-- in place of the time of day.

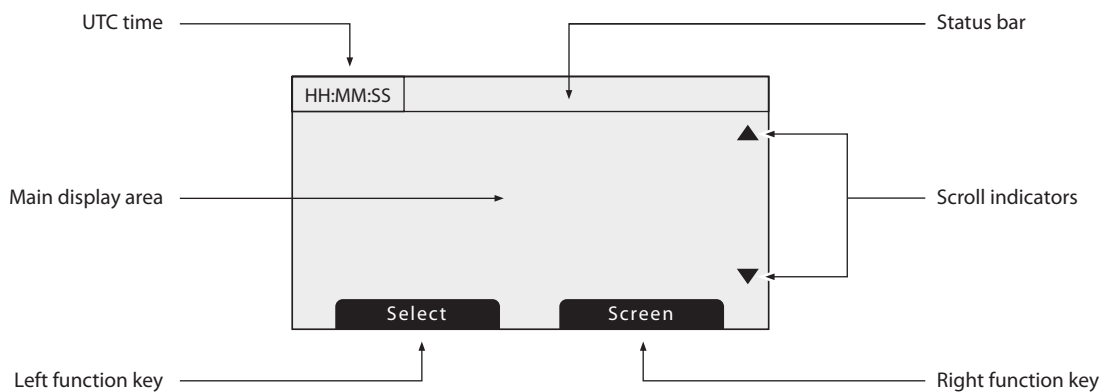

Figure 4 Display layout

3.3.1 Status bar icons

The status bar shows the current transceiver status using icons. The meaning of each icon is described in Table 1.



Icon	Description
OK	The transceiver is operating normally.
Tx	Shown for one second following each transmission.
Rx	Shown for one second following each received message.
INT GPS	Shown when the internal GPS receiver has a valid position fix.
EXT GPS	Shown when a connected external GPS receiver has a valid position fix.
INT DGPS	Shown when the internal GPS receiver has a valid differential position fix.
EXT DGPS	Shown when a connected external GPS receiver has a valid differential position fix.
NO GPS	Shown when there is no valid internal or external position fix.
	Shown when unread AIS safety related text messages are available.
	Shown flashing when an alarm is active, shown constantly when an alarm is active, but acknowledged.
1W	Shown when the transmitter is set to 1W mode.
NO TX	Shown when 'Silent mode' has been activated and the AIS transmitter is disabled
IL	Shown when the AIS transceiver is operating in 'Inland Waterways' mode.

Table 1 Status Icons

3.4 Main operating screens

In normal operation the display shows one of six main operating screens. The next screen can be selected at any time by pressing the 'Screen' function key as shown in Figure 5. The following subsections describe each of the operating screens in more detail.

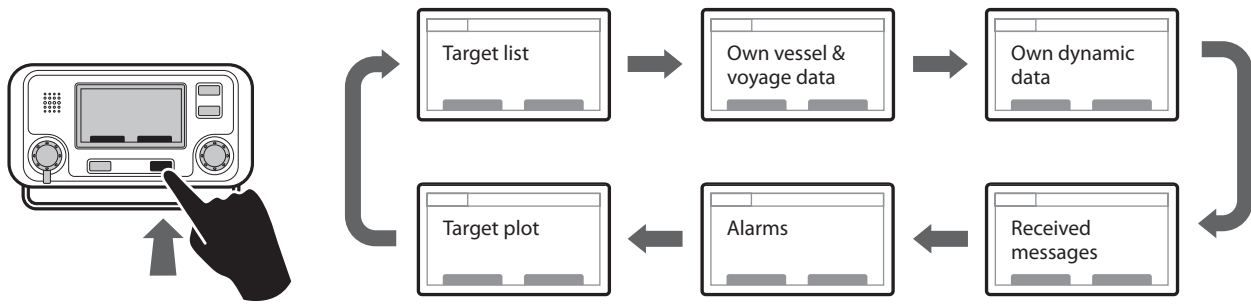

Figure 5 Selection of main operating screen

3.5 Target list

The target list screen is shown by default after power up. This screen shows the name (or MMSI), range (in nautical miles) and bearing (in degrees) of other AIS equipped vessels. The nearest vessel is shown at the top of the list. Only the 200 nearest vessels are shown in the target list, more distant vessels may be viewed if an AIS enabled external display, RADAR or ECDIS is connected to the transceiver.

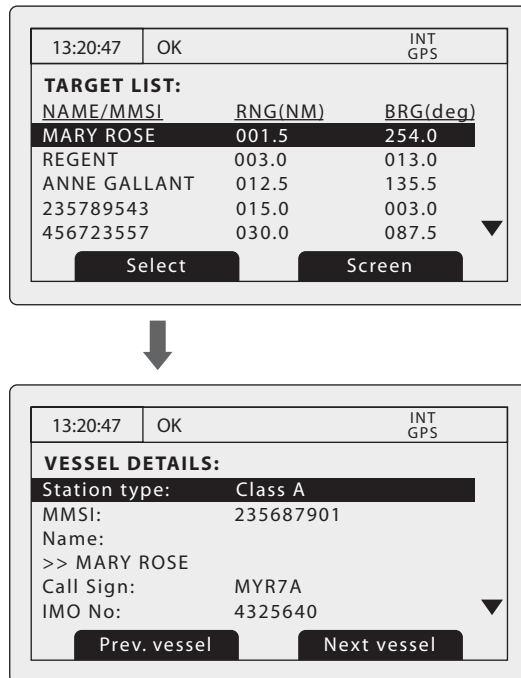

Figure 6 Target list screen and vessel details view

When the target list screen is displayed the scroll wheel can be used to move through the list. Full details of the highlighted vessel can be shown by pressing the 'Select' function key, or pushing the scroll wheel. To return to the target list from the vessel details screen press the 'Back' key. Whilst the vessel details screen is displayed it is possible to view details of the next and previous vessels in the vessel list using the left and right function keys without returning to the target list screen.

3.6 Own vessel and voyage data

This screen shows own vessel and voyage related data. This data relates to the vessel on which the transceiver is installed.

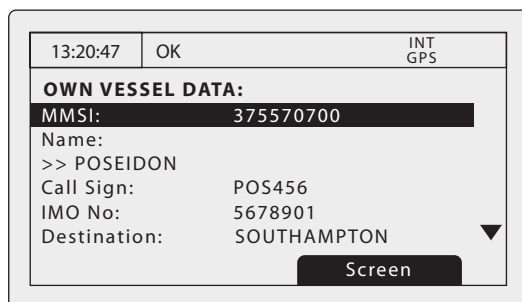

Figure 7 Own vessel and voyage data screen

The information displayed on this screen includes:

- MMSI - the Maritime Mobile Service Identity for the vessel on which the transceiver is installed.
- Vessel name
- Call sign
- Destination - the current voyage destination
- IMO Number
- ETA - Estimated Time of Arrival at the voyage destination
- Draught
- Navigational status - At anchor, underway etc
- Dimensions for internal GNSS antenna
- Crew - number of crew on board
- Type of ship/cargo

The scroll wheel can be used to highlight an item of static or voyage data. To edit voyage or installation data see the 'Voyage data' and 'Installation' menus in section 3.17 and also the installation information in section Table 8.

3.7 Own dynamic data

This screen shows current dynamic data from sensors connected to the transceiver and / or its built in GNSS receiver. This is live information that is being transmitted to other AIS equipped vessels.

The information displayed on this screen includes:

- Current date and time (UTC)
- Latitude
- Longitude
- SOG (Speed Over Ground)
- COG (Course Over Ground)
- Heading
- ROT (Rate Of Turn)
- Position accuracy
- RAIM status
- GNSS in use (internal or external)

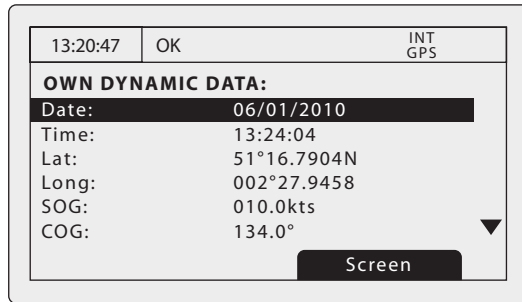

Figure 8 Own dynamic data screen

3.8 Received messages

This screen shows AIS text and Safety Related Messages (SRM) received from other AIS stations. The most recently received message is shown at the top of the list. The date and time of reception, name or MMSI of the sending station and type of message (text or SRM) are shown in the message list. To view the message content select the required message using the scroll wheel, then either press the scroll wheel or the “View” function key.

The received messages screen is shown in Figure 9 and the message details screen in Figure 10. When unread messages are available to view the message icon is shown in the status bar as described in section 3.3.1.

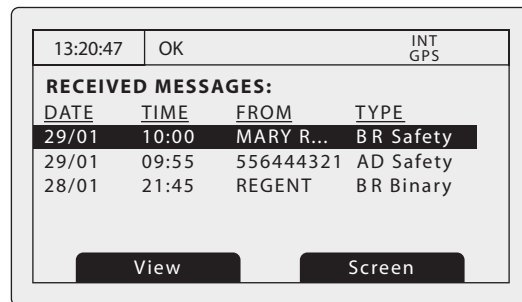

Figure 9 Received messages screen

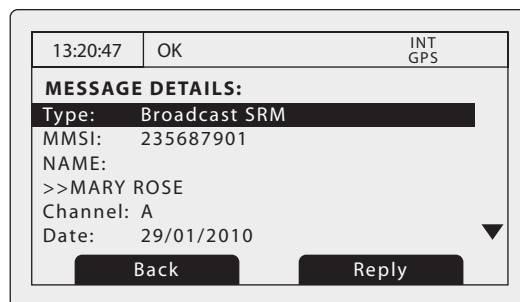

Figure 10 Message details view

3.9 Alarms screen

This screen shows the status of AIS system alarms. If an active and not yet acknowledged alarm condition exists the alarm icon in the status bar will flash. When an alarm condition occurs an acknowledgement screen will be shown immediately, this is described in section 3.12.

The alarms screen shows the date and time of activation along with a brief description of any active alarm and its acknowledge state — see Figure 11. Alarms that are active but not acknowledged by the operator have 'No' in the 'Ack' column. Once an alarm is acknowledged by the operator 'Yes' is displayed in the 'Ack' column. An individual alarm can be selected from the list using the scroll wheel and its details viewed by either pressing the scroll wheel or the "View" function key. The alarm details view is shown in Figure 12.

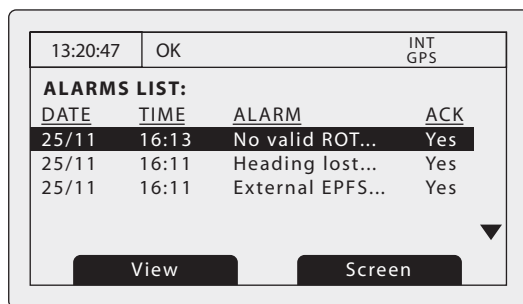

Figure 11 Alarms screen

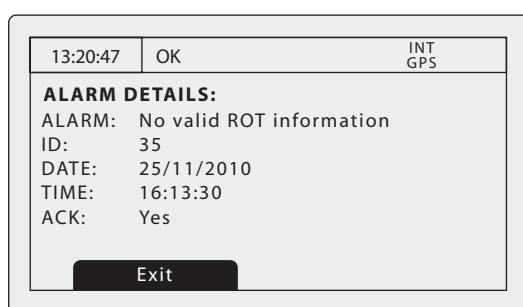

Figure 12 Alarm details view



While un-acknowledged alarm conditions are active then any connected external alarm system will remain activated.

3.10 Target plot screen

The target plot screen shows the location of other AIS equipped vessels and shore stations relative to your own vessel. The target plot screen provides a basic overview of AIS targets and should not be regarded as a substitute for display of AIS information on a dedicated electronic chart display system (ECDIS).

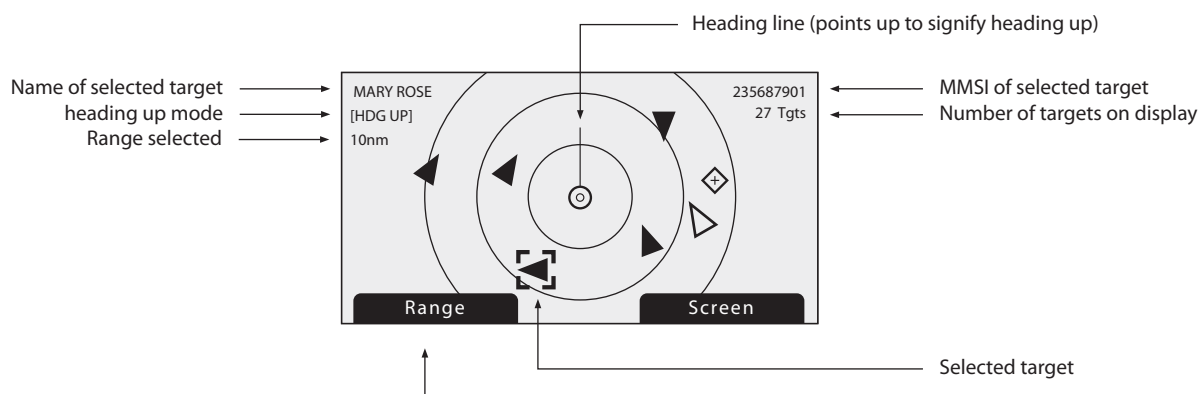

Figure 13 Target plot screen

The plot range can be adjusted by pressing the 'Range' function key which cycles through the ranges 48, 24, 12, 6, 3, 1 and 0.5nm. The range relates to radius of the outer range ring shown on the screen.

Individual targets can be selected using the scroll wheel. When selected a square outline will appear around the target, pressing the scroll wheel will display full vessel details. To return to the target plot screen from the vessel details screen press the back key.

Different symbols are displayed for an AIS target depending on the type of target and its status, these are shown in Figure 14. The own vessel symbol is always shown at the centre of the plot.

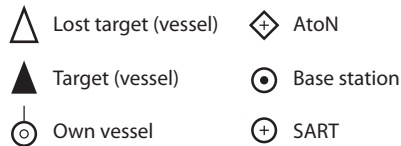

Figure 14 Target plot symbols

3.11 Working with AIS text and Safety Related Messages (SRMs)

AIS text messages and Safety Related Messages (SRMs) can be received from other AIS equipped vessels and also sent to specific vessels (addressed messages) or sent to all vessels in range (broadcast messages).

3.11.1 Receiving AIS text and Safety Related Messages

Reception of an AIS text message is indicated by the presence of the message icon in the status bar. This icon is shown whenever there are unread AIS text messages. Messages can be reviewed and replied to via the messages screen; see 3.8.

When a Safety Related Message is received the user will be notified immediately with a screen showing the message accompanied by three long beeps from the sounder. Standard text messages are not displayed on receipt, however the message icon will be displayed on the status bar.

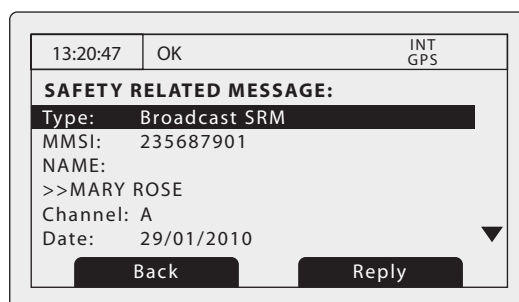

Figure 15 Safety Related Message notification

3.11.2 Sending AIS Text and Safety Related Messages

To compose a new text or Safety Related Message (SRM) press the 'Menu' key then select the 'MESSAGES' sub menu followed by the 'SEND A MESSAGE' option. The new message screen is shown in Figure 16. To send a message complete the following steps:

1. Using the scroll wheel highlight the 'TYPE' field and select the type of message you wish to send. The available options are 'Broadcast text', 'Addressed Text', 'Broadcast SRM' and 'Addressed SRM'. Click the scroll wheel to confirm the message type.
2. For addressed message types only select the 'TO' field and press the scroll wheel. Enter the MMSI of the vessel the message should be sent to using the scroll wheel. See section 3.13 for instructions on using the scroll wheel to enter data.

3. Select the 'MESSAGE' field and enter your message. Note that the length of a message is limited as follows:
 - Addressed SRM 156 characters
 - Broadcast SRM 161 characters
 - Addressed text 151 characters
 - Broadcast text 156 characters
4. Press the 'Send' function key to transmit the message.

When an addressed message is sent the addressee will return an acknowledgement on receipt of the message. If this acknowledgement is not received a warning will be displayed.

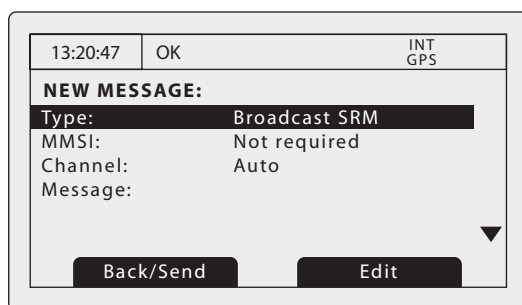

Figure 16 Message composition



Warning: Class B transceivers are permitted to receive broadcast Safety Related Messages and broadcast text messages, however this function is not mandatory. Class B transceivers are not able to receive addressed Safety Related or text messages. There is therefore no guarantee that text messages or SRMs sent to a Class B transceiver will be received.

3.12 Handling alarms

The Poseidon transceiver performs self checking functions continuously. If a self check fails an alarm will occur. Possible alarm conditions are listed in Table 2.

Alarm condition	Description
Transmitter malfunction	This alarm can occur if there is a fault with the transmitter or if the antenna VSWR exceeds allowable limits. The alarm will be cleared if the transmitter recovers normal operation or the VSWR measurement returns to an allowable value. If this alarm condition persists contact your dealer or installer.
Antenna VSWR exceeds limit	This alarm condition can occur if the VSWR (Voltage Standing Wave Ratio) of the AIS antenna exceeds pre-defined limits. This alarm is cleared if the VSWR returns to an allowable value. If this alarm condition persists contact your dealer or installer.
Receiver channel x malfunction	This alarm occurs should the receiver hardware malfunction. The receiver is identified by the value of x. If the receiver returns to normal operation this alarm will be cleared. If this alarm condition persists contact your dealer or installer.
External EPFS lost	This alarm occurs if the position from the external Electronic Position Fixing System (i.e. GNSS) is invalid or lost.
No sensor position in use	This alarm occurs if the transceiver has no valid position information from any connected sensor.

Alarm condition	Description
No valid COG information	This alarm occurs if the transceiver has no valid Course Over Ground information from any connected sensor.
No valid SOG information	This alarm occurs if the transceiver has no valid Speed Over Ground information from any connected sensor.
Heading lost or invalid	This alarm occurs if the transceiver has no valid heading information from any connected sensor, or if the heading is undefined.
No valid ROT information	This alarm occurs if the transceiver has no Rate Of Turn information from connected sensors or via internal calculation.

Table 2 Alarm conditions

A new alarm will be indicated by display of the alarm notification screen (see Figure 17). The alarm icon in the status bar will flash whilst an alarm is active and not acknowledged by the user.

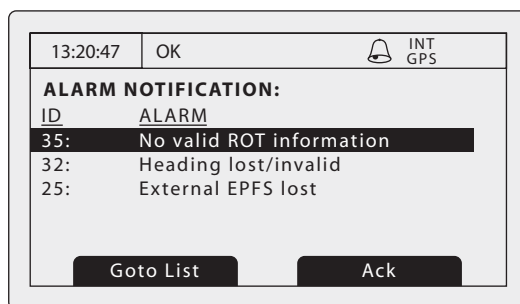

Figure 17 Alarm notification screen

From the alarm notification screen you have the option to immediately acknowledge the alarm by pressing the 'ACK' function key, or to view the active alarms list by pressing the 'Goto List' function key. Once an alarm is acknowledged it will remain in the alarms list whilst the underlying alarm condition is active. The presence of active but acknowledged alarm conditions is indicated by continuous display of the alarm icon in the status bar.

3.13 Entering text

The scroll wheel is used to enter text when updating settings or inputting new information. To enter or change the text first select the field you wish to edit using the scroll wheel. The selected field is highlighted with white text on a black background.

If the field is editable the 'Edit' function key will be shown. Either press this function key, or push the scroll wheel to enter edit mode.

If text is already present in the field a solid block will now appear at the last character position, otherwise at the first character position. Use the scroll wheel to move the block to the character position you wish to edit, then press the scroll wheel. The selection will now flash, and rotating the scroll wheel will select the character for this position. When the correct character is selected press the scroll wheel to fix the character and move to the next character position. To 'backspace' (delete) a character simply press the 'Back' key. Figure 18 explains the text entry process.

When you have completed entering text press the 'Save' function key to save the updated information.

3.14 Disabling the display

It is possible to disable the display by holding down the Menu key for more than 3 seconds. This will also switch off all display lighting around the keys and scroll wheel. Pressing any key will re-enable the display and other display lighting. Whilst the display disabled the transceiver continues to operate normally.

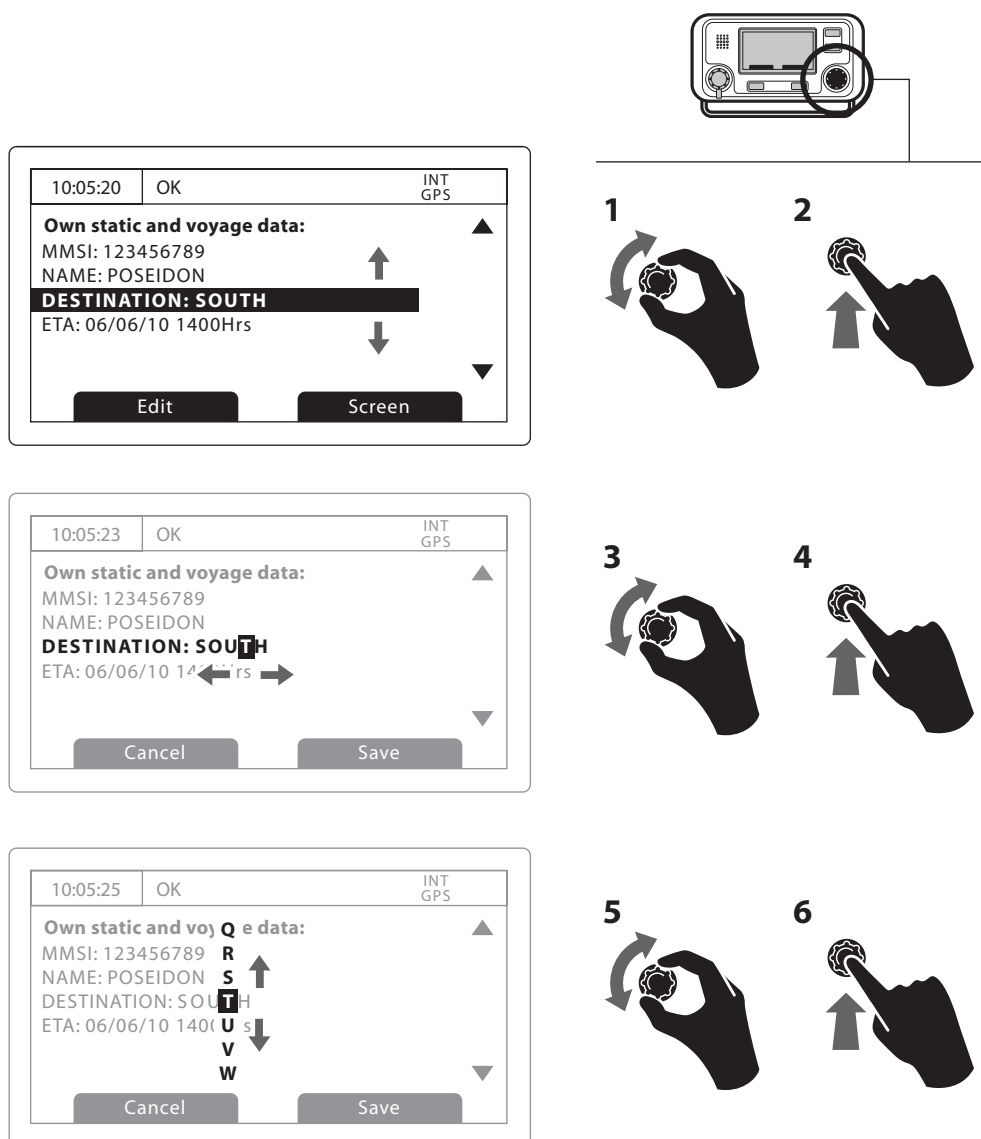

Figure 18 Text entry

3.15 Long range messages

If the Poseidon transceiver is connected to a long range communication system via the long range communications port then long range interrogations may be received. These are requests for information from a distant base station beyond normal AIS operation range.

The Poseidon transceiver can be configured to automatically respond to Long range (LR) interrogations, or you can opt to respond to any interrogation manually. Automatic response is the default setting, see section 3.17 for details of the menu option used to change this setting. Note that in automatic mode all requested information is returned if it is available.

When a Long range interrogation is received you will be alerted by a notification screen as shown in Figure 19 (when automatic response is enabled) or Figure 20 (when manual response is enabled).

In automatic response mode simply review and acknowledge the notification screen using the 'Acknowledge' function key to return to the previous operating screen. In manual response mode you should review the request and select either the 'Respond' or 'Decline' function key as appropriate.

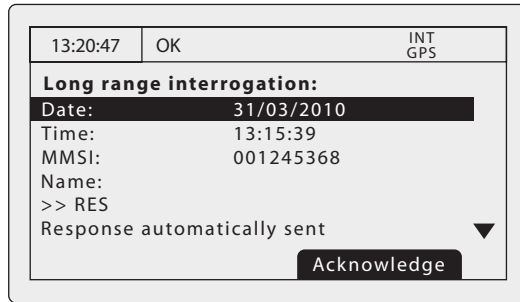

Figure 19 Long range interrogation notification; automatic response mode enabled

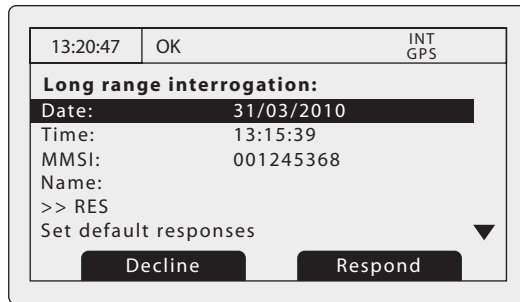

Figure 20 Long range interrogation notification; manual response mode enabled

A list of received Long range interrogation messages is available at any time via the main menu 'Messages' sub menu. See section 3.17 for more details. The Long range message list shows the time and date of reception of each message along with the sending base station's MMSI. Full details on each Long range interrogation in the list can be viewed by pressing the 'View' function key. The Long range message list and details views are shown in Figure 21.

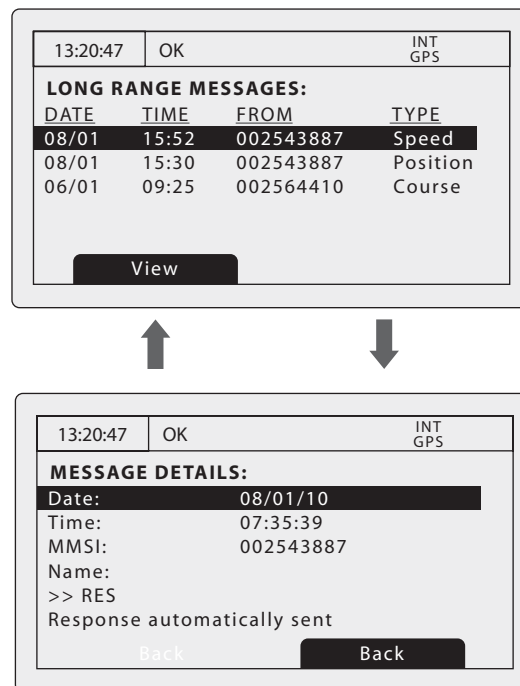

Figure 21 Long range message list and details views

3.16 Passwords and security

Certain important information stored within the transceiver can not be changed without knowledge of the password. The protected information includes:

- MMSI number
- Name of vessel
- Call sign
- IMO number
- Channel management settings
- Vessel dimensions and GNSS antenna locations
- Type of ship
- Data interface configuration

When trying to edit any of the above information you will be prompted to enter the password.



The default password is 000000. The password may have been changed during installation. For further information on changing the password refer to section Table 10.

The password entry screen is shown in Figure 22. Use the scroll wheel to select the required digit, then push the scroll wheel to edit the value of that digit. Entered password digits are masked by asterisks, when complete press the scroll wheel to enter the password.

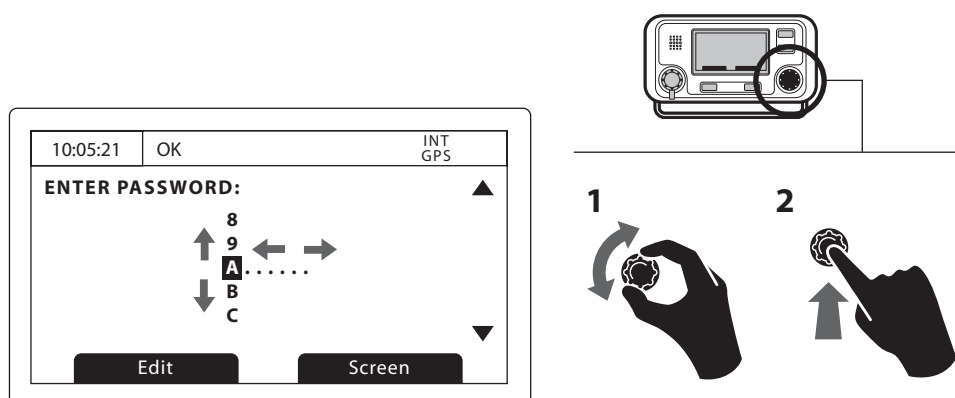

Figure 22 Password entry screen

The default password can be changed via the configuration menu '*Installation*' sub menu. Refer to section 3.17 for further details.

3.17 The configuration menu

The transceiver configuration menu can be accessed at any time by pressing the '*Menu*' key. The menu is navigated by rotating the scroll wheel to select a sub-menu or menu item, and pressing the scroll wheel to select that sub-menu or menu item. Pressing the '*Back*' key will go back to the previous menu level, or exit the menu system if you are currently viewing the top level menu. Figure 24 shows the main menu screen.

You can return to the top level menu at any time by pressing the '*Menu*' key, and exit the menu system at any time by pressing and holding the '*Back*' key for one second.

The main menu structure is shown in Figure 23. Some menu items are password protected and can only be accessed using the password (see section 3.16).

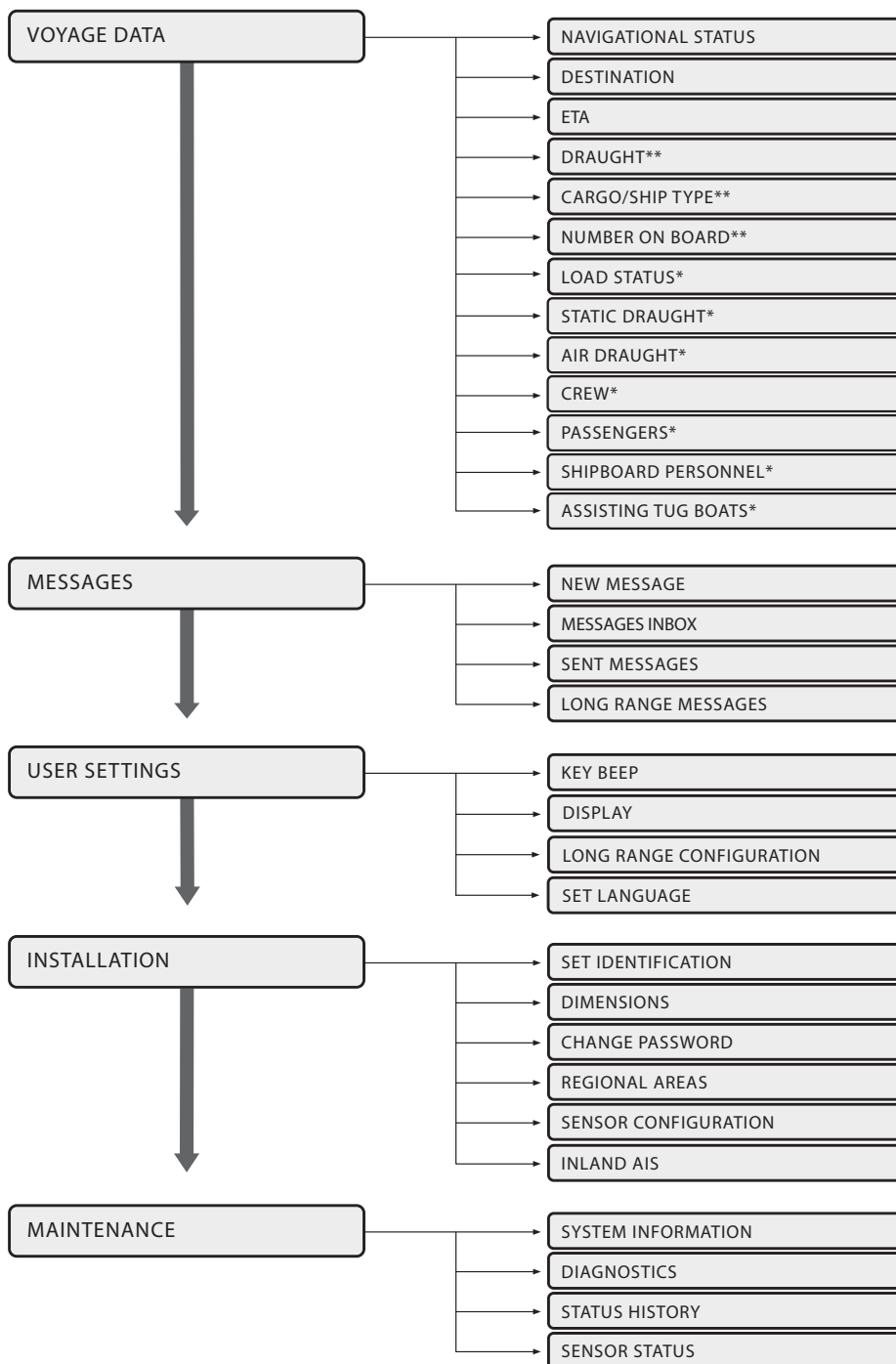

** Shown in 'High Seas' mode only

* Shown in 'Inland AIS' mode only

Figure 23 Main menu structure

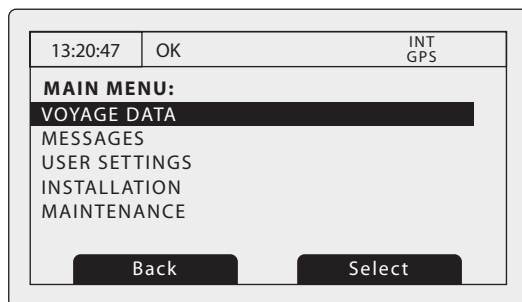

Figure 24 Main menu screen

3.17.1 Voyage data menu

The voyage data menu provides quick access to the most commonly changed AIS transceiver parameters.

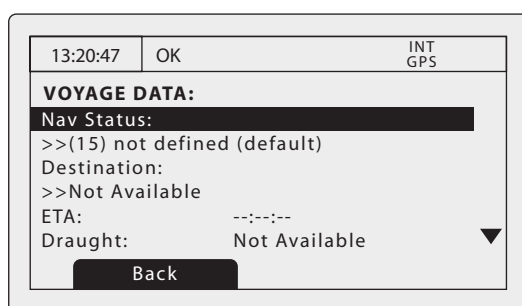

Figure 25 The voyage data menu

From this menu you can set the following parameters:

- Navigational status - select the most appropriate navigational status for your vessel from the list.
 - Under way using engine
 - At anchor
 - Not under command
 - Restricted manoeuvrability
 - Constrained by her draught
 - Moored
 - Aground
 - Engaged in fishing
 - Under way sailing
 - Not defined (default)
- Destination - enter the destination for the current voyage, 20 characters maximum.
- ETA - enter the estimated time and date of arrival at the destination. The date format is DD/MM and the time format HH:MM using a 24 hour clock and UTC time.
- Draught - enter the maximum present static draught for your vessel in metres. The format for this value is xx.x m (e.g., 02.5m). The maximum draught is 25.5m, you should enter this value if your draught exceeds 25.5m.
- Cargo/ship type - see section 4.5.3.
- Number on board - number of crew on board, up to 8191 maximum.

3.17.2 Messages menu

The messages menu provides access to AIS text and safety related message functions along with long range messaging functions.

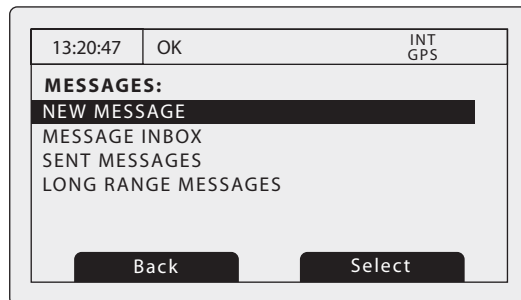

Figure 26 The messages menu

The available options are:

- New message - takes you to the message composition screen as described in 3.8.
- Message Inbox - takes you to the received message list view as described in 3.8.
- Sent messages - shows a list of recently sent messages.
- Long range messages - view a list of received long range messages as described in 3.15.

3.17.3 User settings menu

The user setting menu provides access to user configurable preferences for the Poseidon transceiver. All user settings are stored within the transceiver and will be maintained if the power supply is switched off.

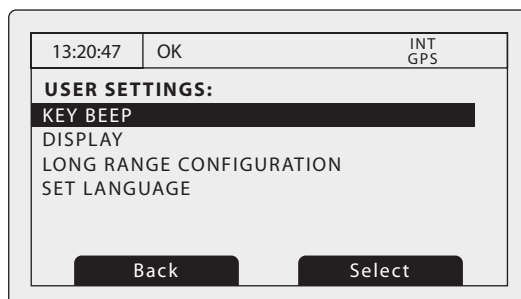

Figure 27 The user settings menu

The available options are:

- Key beep - the key press beep can be enabled or disabled.
- Display - brightness and contrast adjustment for the LCD display along with selection of day or night operating mode. In night mode the display colours are inverted (light text on a dark background). Settings for contrast and brightness are stored separately for day and night display modes and will be recalled when the display mode is changed.
- Long range message configuration - set up automatic or manual response to long range messages.
 - With automatic response enabled a reply will automatically be sent to any Long Range interrogations received. You will be notified that an interrogation has occurred as described in 3.15. This is the default setting.
 - With manual response enabled you will be given the opportunity to respond or decline to respond to any Long Range interrogations received. The notification is described in 3.15.
- Set language - select the user interface language from the available language options

3.17.4 Installation menu

The installation menu provides access to settings that are required during installation of the Poseidon transceiver. Please refer to the installation section of this manual for more detailed information on installation settings and requirements. Some settings in the installation menu are password protected and should only be adjusted by authorised personnel.

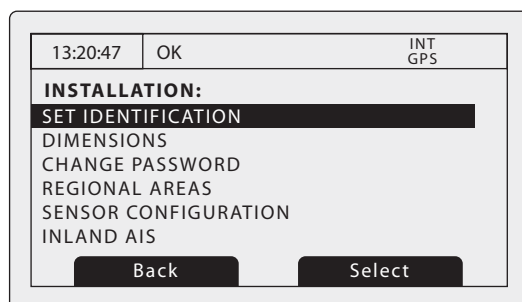

Figure 28 The installation menu

The available settings and options are:

- Set identification - entry of vessel identification information including MMSI number, name, call sign, vessel type and IMO number. This menu is password protected.
- Dimensions - entry of vessel dimensions and location of internal and external GNSS antennas. This menu is password protected.
- Change password - entry of a new password to protect installation settings. This menu is password protected.
- Regional areas - through this menu option the user can list, edit and add regional area definitions. See section 4.8. This menu is password protected.
- Sensor configuration - this sub menu allows the communication speed of the three sensor data input ports. See section 4.4.3. This menu is password protected.
- Inland AIS Settings - see section 3.18.

3.17.5 Maintenance menu

The maintenance menu provides access to Poseidon system information and operating diagnostics. These features are intended for use by authorised installers and service agents only. Access to some maintenance features are protected by the password.

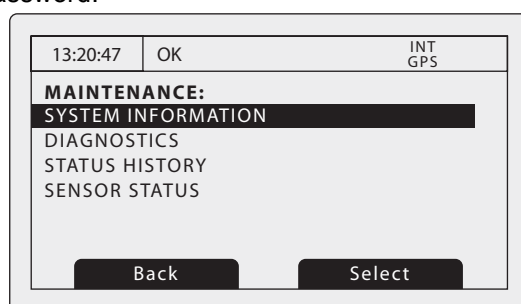

Figure 29 The maintenance menu

The available settings and options are:

- System information - selecting this item will display internal configuration information.
- Diagnostics - selecting this item will display internal diagnostic information.
- Status history - will display a list of recent transceiver status messages (AITXT). A list of possible status messages and their meaning is provided in Table 3.
- Sensor status - will display the status of external sensors.

Text message	Description
AIS: UTC clock lost	The internal GNSS receiver is not providing timing information to the AIS. Position reports will continue to be made.
AIS: external DGNSS in use	An externally connected differential GNSS is being used as AIS position source.
AIS: external GNSS in use	An externally connected GNSS is being used as AIS position source.
AIS: internal DGNSS in use (beacon)	The internal GNSS, corrected by data from a connected beacon receiver is being used as AIS position source.
AIS: internal DGNSS in use (message 17)	The internal GNSS, corrected by data from an AIS base station is being used as AIS position source.
AIS: internal GNSS in use	The internal GNSS is being used as AIS position source.
AIS: external SOG/COG in use	An external source of SOG / COG data is being used as source of speed and course data.
AIS: internal SOG/COG in use	Internal GNSS SOG / COG data is being used as source of speed and course data.
AIS: Heading valid	The connected source of heading data is valid.
AIS: Rate of Turn Indicator in use	The connected ROT sensor data is valid
AIS: Other ROT source in use	Rate of turn information is based on Heading data.
AIS: Channel management parameters changed	The AIS has received commands to use alternate reporting channels (from an AIS base station)

Table 3 Status history message descriptions

3.17.6 Diagnostics

Certain diagnostics information is provided to assist with installation and maintenance of the transceiver. This can be accessed via the Maintenance menu. Figure 30 shows the diagnostics menu page. A number of features can be accessed via the diagnostics menu:

- Internal GPS status provides GPS lock status, number of satellites in view and in use and the mode of use.
- ADC and VSWR data provides internal system information for use in installation and maintenance only
- Sensor port status provides details of sensor port settings.

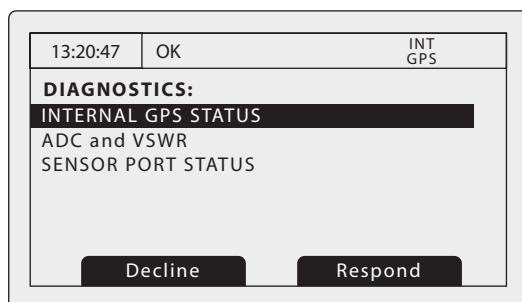

Figure 30 Diagnostics menu

3.18 Inland AIS

The Poseidon transceiver supports both standard 'high seas' operation and 'Inland AIS' operation. Inland AIS is an extension of AIS intended for use on board vessels navigating inland waterways.

During installation the transceiver will be configured appropriately for either high seas or inland operation. When the transceiver is configured for inland operation the 'IL' icon will be displayed on the status bar (see section 3.3.1). Information on enabling / disabling inland AIS mode along with additional configuration required for inland operation can be found in section 4.9.

3.18.1 Own vessel and voyage data display in Inland AIS mode

Additional own vessel and voyage related data is displayed on the main operating screens in inland AIS mode. The following additional information is displayed on the own vessel data screen (as described in section 3.6). When scrolling through the own vessel data screen the following additional information is shown:

- Blue sign status is displayed as either 'Yes' (the sign is set), 'No' (the sign is not set) or 'not available' when the blue sign switch is not installed. If a blue sign switch is installed it should be manually switched to the appropriate setting during navigation (see section 3.18.4).
- The IMO number is set to '0' or '0000000' when operating in inland AIS mode.
- The call sign is replaced with the ATIS code when operating in inland AIS mode.
- The dimensions of the vessel are set to the maximum rectangular size of the convoy when operating in inland AIS mode.
- The destination is displayed as a UN location code and ERI terminal code.
- The ENI (unique European Vessel Identification Number) for the vessel is shown.
- The ship (or combination type) is shown using an ERI classification code. A table of ERI codes is provided in section for reference.
- The load status of the vessel is displayed as 'Loaded' or 'Unloaded'.
- The number of crew, passengers and other shipboard personnel will be displayed.

3.18.2 Target vessel details display in Inland AIS mode

Additional detail relating to target vessels is available when operating in inland AIS mode. The additional information is only displayed for target vessels which are also equipped with an inland AIS transceiver and are transmitting inland AIS data.

The target vessel details display described in section 3.5 will show the following additional data:

- Blue sign status is displayed as either 'Yes' (the sign is set), 'No' (the sign is not set) or 'not available'.
- The IMO number is not shown for inland target vessels, the ENI (unique European Vessel Identification Number) for the vessel is shown instead.
- The target vessels call sign shows its ATIS code.
- The displayed dimensions of the vessel are the maximum rectangular size of the convoy.
- The target vessel destination is displayed as a UN location code and ERI terminal code

- The ship (or combination type) is shown using an ERI classification code. A table of ERI codes is provided in section for reference.
- The load status of the vessel is displayed as 'Loaded' or 'Unloaded'
- Quality of speed, course and heading information will be shown as 'high' when the target vessel is using an approved sensor to generate this data, or low if the data is derived from internal GNSS only.
- The number of crew, passengers and other shipboard personnel will be displayed.

3.18.3 Setting voyage data in Inland AIS mode

Additional voyage related information is required for Inland operation along with some changes to the standard AIS configuration. The following additional information must be entered into the AIS transceiver:

- The vessels load status as 'loaded' or 'unloaded'.
- The number of blue cones or blue flag status for the cargo (1, 2 or 3 blue cones, or blue flag).
- The static draught of the vessel to the nearest centimetre.
- The air draught of the vessel to the nearest centimetre.
- The number of crew (0 to 254 or unknown), passengers (0 to 8190 or unknown) and other shipboard personnel (0 to 254 or unknown).
- The number of assisting tugboats (from 0 to 6).

The additional identification information can be entered via the main menu. Press the '*Menu*' key then select the 'Voyage data' sub-menu. When the AIS transceiver is operating in Inland AIS mode the voyage data entry screen will be extended to allow input of the additional information described above.

The following standard AIS voyage information must be updated for Inland AIS:

- Destination

The voyage destination should be entered using UN terminal location codes and ERI terminal codes where possible.

3.18.4 Blue sign operation

A 'blue sign' switch may optionally be connected to the AIS transceiver during installation. This switch sets the 'blue sign' status in transmitted inland AIS position reports to either 'Set' or 'Not set'. If a blue sign switch is not installed the blue sign status is transmitted as 'not available'.

If a blue sign switch is installed it should be set according to the current navigational situation. The current blue sign status will be displayed on the own vessel data screen.

4 Installation

The **Poseidon** AIS transceiver has been designed for ease of installation. The transceiver is a 'one box' design containing both the transceiver and display. An external junction box is provided to simplify connection of sensor and display data wiring. A typical system and connection diagram is provided in Figure 31.

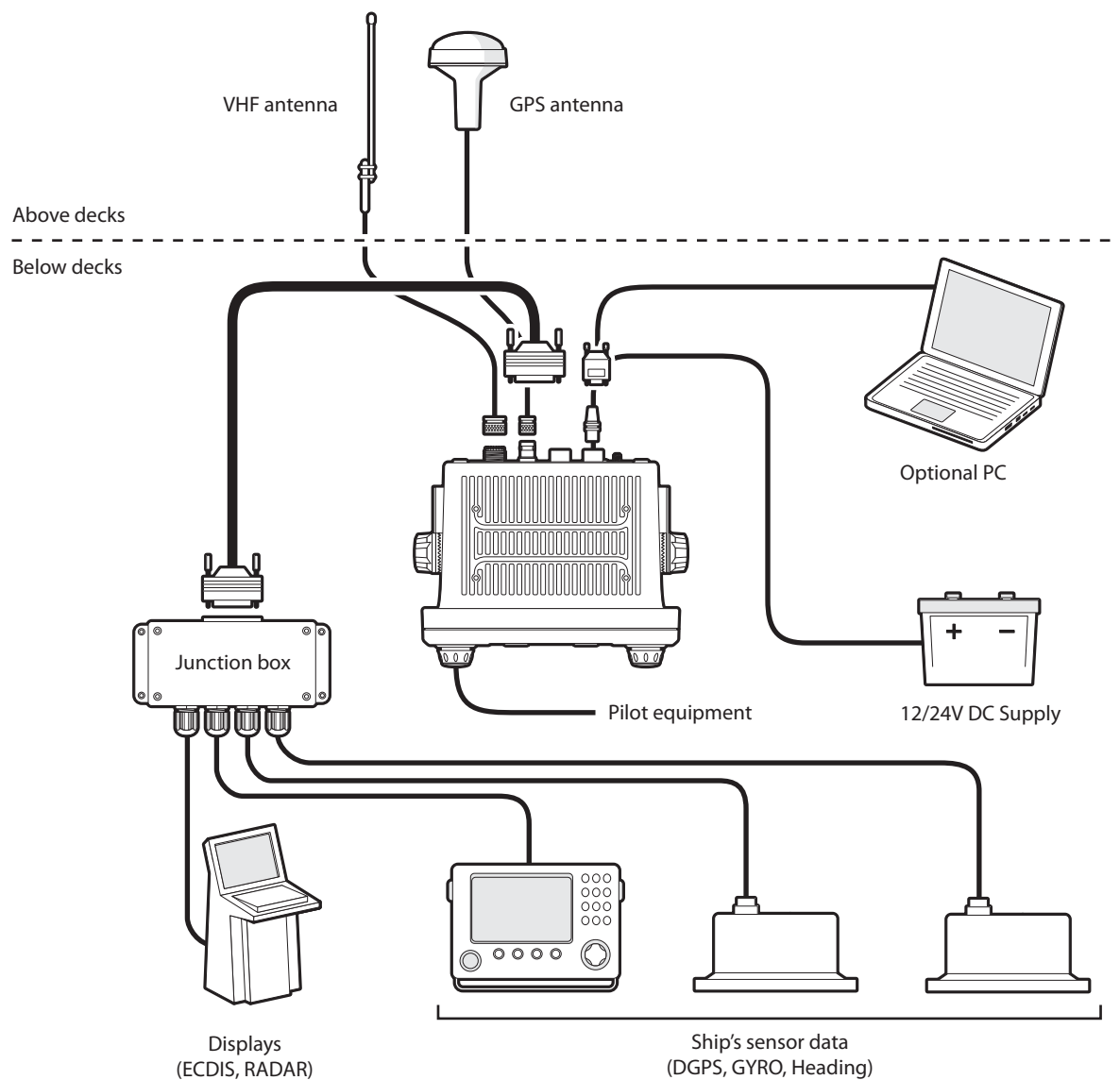

Figure 31 Typical AIS transceiver connection

The main elements of installation are:

1. Mount the transceiver and junction box in a suitable location.
2. Install VHF antenna according to manufacturers instructions.
3. Install the GPS antenna.
4. Connect data interfaces.
5. Apply power and configure the transceiver.
6. Confirm correct operation.
7. Complete the installation log.

4.1 What's in the box?

Figure 32 shows the items included with your AIS transceiver purchase. The following section gives a brief overview of each item. Please ensure all items are present and if any of the items are missing please contact your dealer.

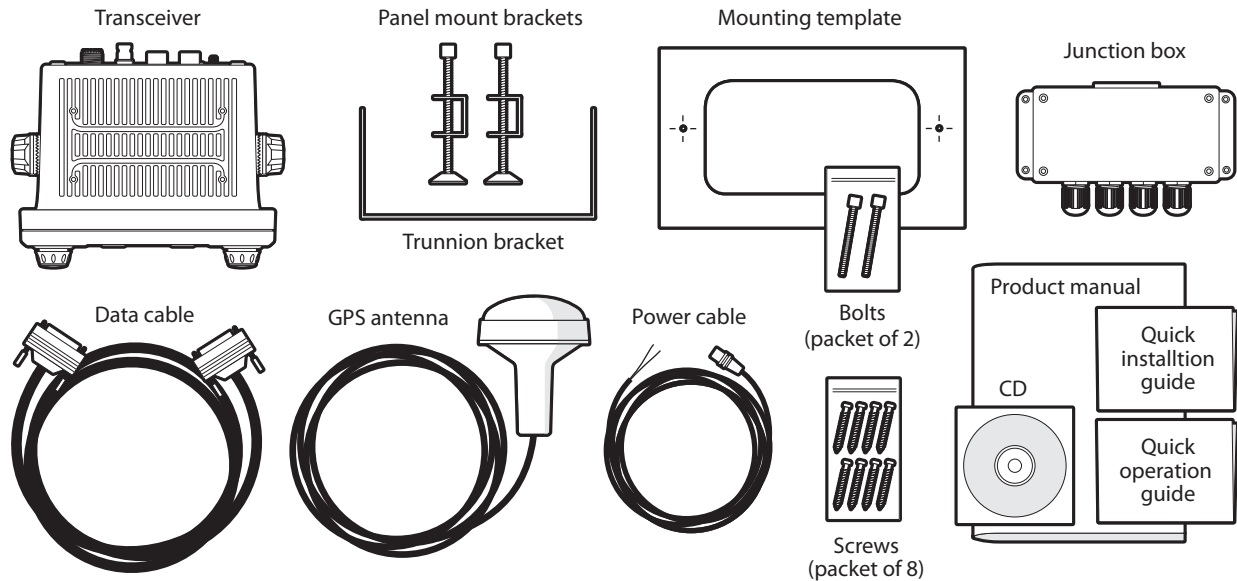

Figure 32 What's in the box

- **Poseidon Class A AIS transceiver**
The main transceiver and display.
- **Data cable**
A 1m (3.3ft) long, 50 way data cable to connect the transceiver serial data ports to the junction box.
- **Junction box**
Provides screw terminals for the data connections to ships sensors and display systems.
- **Power cable**
A 2m (6.6ft) long power cable to supply the transceiver. The power cable also include alarm output connections.
- **Trunnion bracket**
Bracket for mounting the transceiver above a flat surface (e.g., on top of an instrument panel).
- **Panel mount brackets**
Clamp brackets used when mounting the transceiver through a panel (flush mount).
- **Fixing screws**
Eight fixing screws are provided for mounting the transceiver (when using the trunnion bracket) and the junction box.
- **User and installation manual**
This document - please read thoroughly before attempting to install and commission the transceiver.
- **Quick start guide**
The quick start guide gives a handy one page reference for the installation process.
- **Support tools CD**
Contains software tools for configuration of the AIS transceiver and software upgrade.
- **Mounting template**
Template for cutting an aperture when panel mounting the transceiver.

4.2 Preparing for installation

In addition to the items provided with the Poseidon transceiver the following items will be required to complete the installation:

4.2.1 VHF Antenna

Connection of a suitable VHF antenna will be required for the AIS transceiver to operate. A standard marine band VHF antenna such as that used with VHF voice radios is sufficient. The antenna cable should be terminated with a PL-259 (or UHF) connector. Please take note of the warnings listed at the start of this manual regarding the installation and use of antennas.

4.2.2 Antenna cables

The supplied GPS antenna is provided with 10 metres (32.8ft) of cable. If this is not sufficient to reach between the desired GPS antenna location and the AIS transceiver you will require an extension cable. Please contact your dealer for details. For reference the GPS antenna connector type on the AIS transceiver is a TNC receptacle and is intended to mate with a TNC jack connector on the GPS antenna cable.

4.2.3 GPS antenna mount

A mounting bracket is required for the supplied GPS antenna. The antenna has a standard one inch 14 TPI pole mount thread. You should source and install a compatible antenna bracket suitable for the installation location.

4.2.4 Data interface cables

Suitable screened, multi core cable will be required to connect the ships sensor (DGPS, Gyro etc.) data ports to the AIS junction box.

4.3 Installation procedures

Before beginning installation of your AIS transceiver, please ensure you have the necessary additional items as detailed in section 4.2. It is strongly recommended that you read all of the instructions in this manual prior to installation.

If after reading this manual you are unsure about any aspect of the installation process please contact your dealer for advice. The following sections explain the installation process step by step for each of the main system elements.

4.3.1 Step 1 - Installing the AIS transceiver

Please note the following guidelines when selecting a location for your AIS transceiver:

- The AIS transceiver must be fitted in a location where it is at least 30cm (1ft) from a compass or any magnetic device.
- There should be adequate space around the AIS transceiver for routing of cables. See Figure 33 for details of the AIS transceiver dimensions.
- The ambient temperature around the AIS transceiver should be maintained between -15°C and +55° (5°F to 131°F). Ensure adequate ventilation is present when panel mounting the transceiver.
- The AIS transceiver should not be located in a flammable or hazardous atmosphere such as in an engine room or near to fuel tanks.
- The AIS transceiver must be installed in a 'below decks' environment protected from the weather.
- The transceiver is supplied with four self tapping screws for attachment of the AIS transceiver to a suitable surface using the trunnion bracket. Please refer to Figure 34 for guidance.
- The transceiver is supplied with panel mount clamps for flush mounting through an instrument panel. Please refer to Figure 35 for guidance.
- The AIS transceiver should be mounted in a location where the display is visible to the user at the position from which the vessel is normally operated.

- An AC power port should be available near to the pilot plug. A pilot plug is located on the front panel of the AIS transceiver and can also be relocated using the junction box. Please refer to section 4.4.2 for guidance.

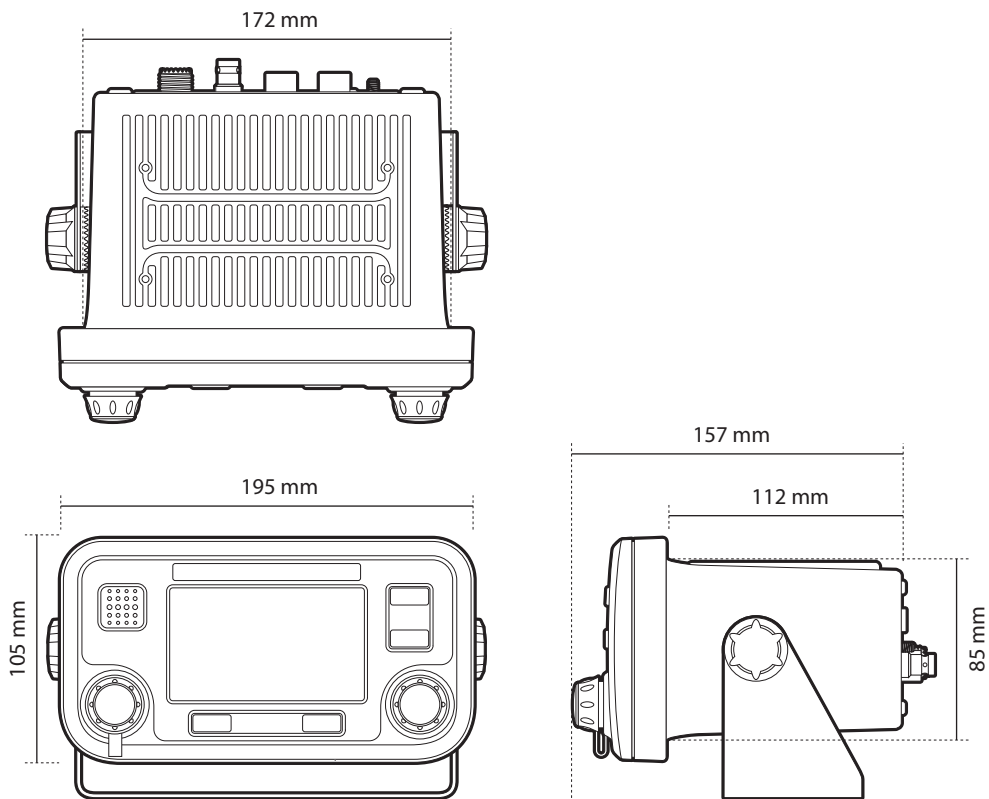

Figure 33 AIS transceiver dimensions

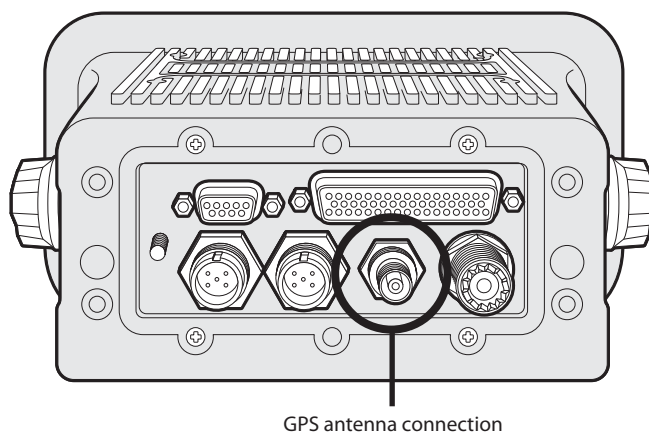

Figure 34 Mounting the AIS transceiver

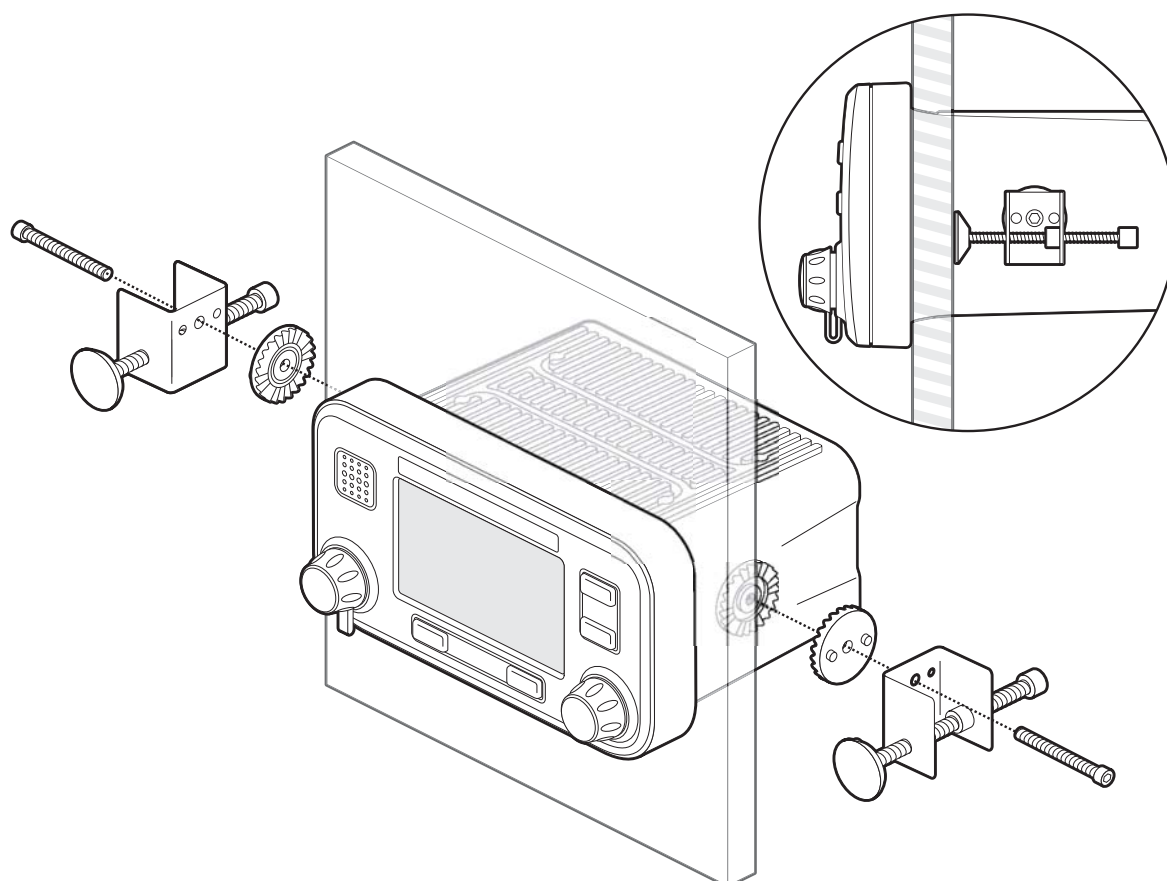

Figure 35 Panel mounting the AIS transceiver

4.3.2 Step 2 - Installing the junction box

The AIS transceiver receives data from the ship's sensors via the 50 way data cable which connects to the rear of the transceiver. The other end of this cable is connected to the junction box which provides a convenient screw terminal system for connection of ships sensor data cables.



To meet IMO requirements the AIS transceiver must be able to transmit at least *Speed over Ground (SOG)*, *Course over Ground (COG)* and *Rate of Turn (ROT)* information. This data is obtained by connecting data outputs from the ship's DGPS, Gyrocompass and other sensors to the transceiver via the junction box.

Please note the following guidelines when selecting a location for the AIS junction box:

- There should be adequate space around the junction box for routing of cables. See Figure 36 for details of the junction box dimensions.
- The ambient temperature around the junction box should be maintained between -15°C and $+55^{\circ}$ (5°F to 131°F).
- The junction box should not be located in a flammable or hazardous atmosphere such as in an engine room or near to fuel tanks.
- The junction box must be installed in a 'below decks' environment protected from the weather.
- The transceiver is supplied with four self tapping screws for attachment of the junction box to a suitable surface. Please refer to Figure 37 for guidance.
- The junction box must be located within 1m (3.2ft) of the AIS transceiver to allow for the length of the supplied data interface cable.

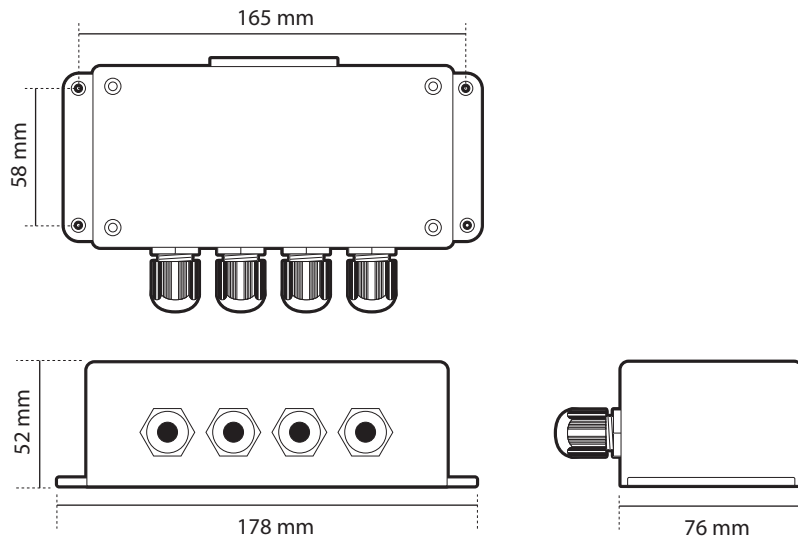

Figure 36 Junction box dimensions

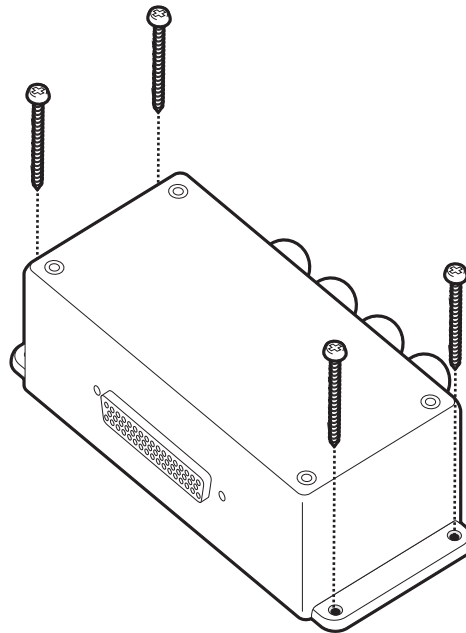

Figure 37 Mounting the junction box

4.3.3 Installing the GPS antenna

The Poseidon AIS transceiver includes an internal GPS receiver for time synchronisation. An independent GPS antenna is required for this receiver in addition to any GPS equipment already installed on board.

For mounting of the GPS antenna supplied with your AIS transceiver you will require a one inch 14 TPI pole mount. Contact your dealer to source a mount suitable for the installation location.

Please note the following guidelines when selecting a location for the GPS antenna:

- The GPS antenna mount should be secured to a rigid surface.
- The GPS antenna should be located where it has a clear, unobstructed view of the sky overhead.
- The GPS antenna should be mounted as high as possible, however it is not recommend the antenna is mounted on a high mast where the motion of the vessel will cause the antenna to swing and potentially reduce the accuracy of the GPS position. See Figure 38 for guidance.

- Mount the antenna at least 5m (16ft) from any RADAR or Satellite communications antennas, and ensure the GPS antenna is not in the beam path from any RADAR antenna.
- Route the GPS antenna cable through the pole mount and then to the AIS transceiver. If extension cables are required all junctions should be made using appropriate co-axial connectors and made watertight.
- Connect the GPS antenna cable to the GPS connector on the AIS transceiver as shown in Figure 39.

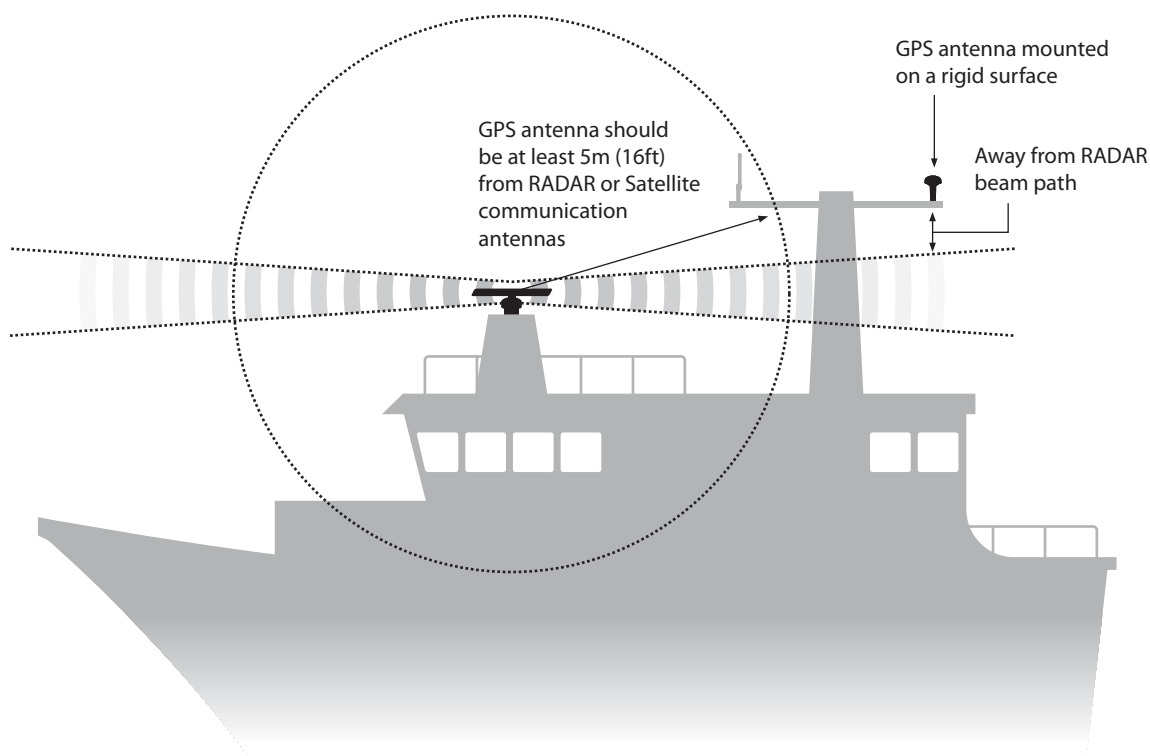

Figure 38 GPS antenna location

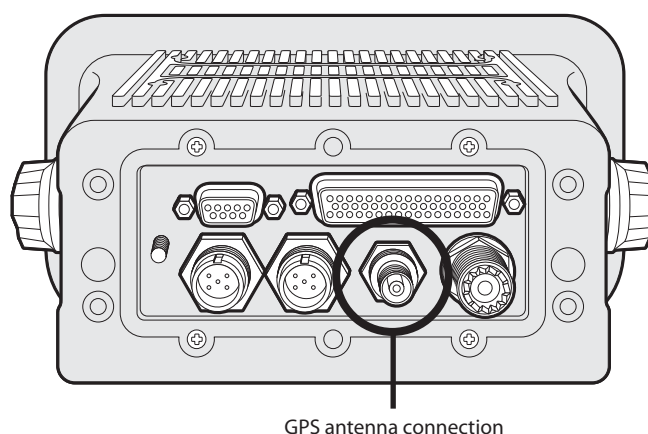

Figure 39 GPS antenna connection

4.3.4 Installing the VHF antenna

The Poseidon AIS transceiver requires a dedicated VHF antenna for communications. A standard marine VHF antenna is suitable. AIS specific VHF antennas are also available that can provide enhanced performance.

Please note the following guidelines when selecting and locating the AIS VHF antenna:

- The VHF antenna should be located as high as possible and positioned as far from other antennas as possible.
- The VHF antenna should have omnidirectional vertical polarisation.
- The VHF antenna should be installed at least 3m (10ft) away from other transmitting radio, satellite and RADAR antennas.
- Ideally the AIS VHF antenna should be mounted directly above or below the ship's primary VHF radiotelephone antenna, with no horizontal separation and with a minimum of 2m vertical separation. If it is located on the same horizontal level as other antennas, the distance apart should be at least 10m. Refer to Figure 40 for further guidance.
- The VHF antenna cable should be kept as short as possible to minimise signal loss. Double screened co-axial cable equivalent to RF214 are recommended.
- The VHF antenna cable should be terminated in a PL-259 co-axial connector for connection to the AIS transceiver.
- Any outdoor installed connectors in the antenna cables should be waterproof by design.
- Antenna cables should be installed in separate signal cable channels at least 10cm (4ins) away from power supply cables. Crossing of cables should be done at right angles and sharp bends in the antenna cables should be avoided.
- Connect the VHF antenna cable to the VHF connector on the AIS transceiver as shown in Figure 41.

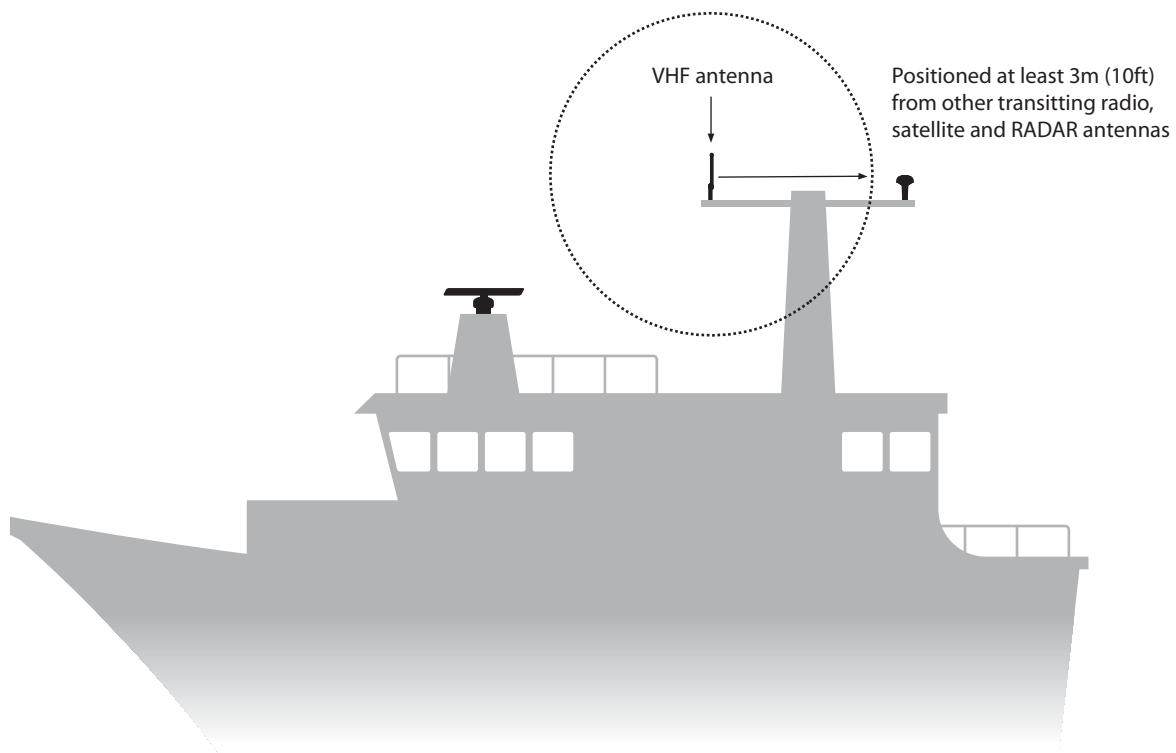

Figure 40 VHF antenna installation

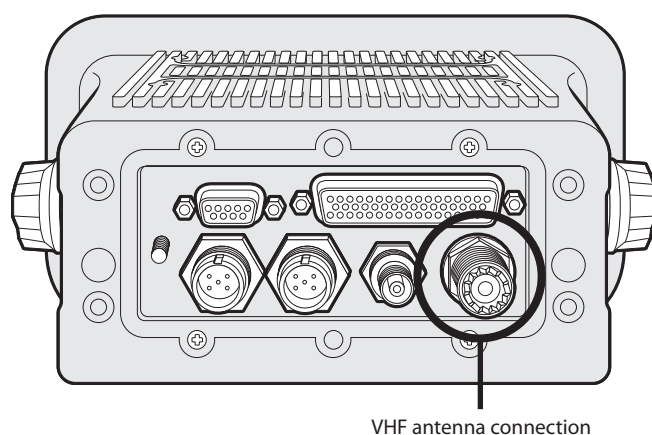

Figure 41 VHF antenna connection

4.4 Connecting the equipment

With the transceiver, junction box and antenna installed it is now possible to connect the equipment in preparation for commissioning.

4.4.1 Antenna connections

If antenna connections have not already been made the GPS and VHF antennas should now be connected to the transceiver. Refer to 39 and 41 for guidance

4.4.2 Data connections

The Poseidon transceiver is supplied with a 1m (3.2ft) 50 way data cable for interconnection of the transceiver and junction box.

Connect the junction box to the transceiver using the data cable as indicated in 42.

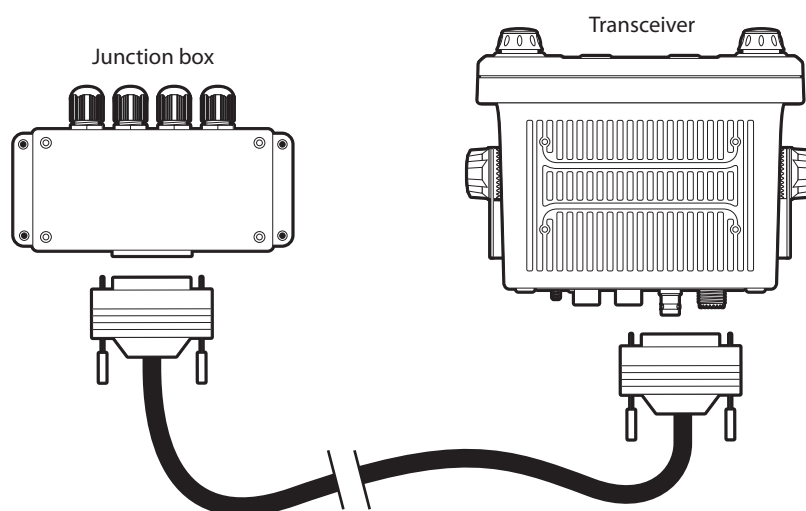

Figure 42 Connecting the junction box to the transceiver

4.4.3 Sensor configuration

The Poseidon transceiver has six NMEA0183 (IEC61162-1/2) data ports for connection of ship's sensors and display equipment as described in Table 4. There are three input ports for ship's sensor data and three bidirectional ports for connection of display equipment such as electronic chart displays. It is recommended that an AIS compatible electronic charting system is connected to the Poseidon transceiver for display of AIS targets. To comply with IMO regulations the AIS must be connected to speed over ground (SOG), course over ground (COG), heading, rate of turn (ROT) and position information sources.

The three sensor ports are input only data ports for the connection of data from ships sensors. The four remaining ports are bi-directional high speed connections supporting data input and output from the AIS. These ports are suitable for connection to ECDIS, AIS enabled RADAR displays and Pilot equipment.

All data input connections are optically isolated.

Data port	Function	Type	Default Baud rate
1	Sensor 1 input (DGPS - COG/SOG/LAT/LON)	Receive only	4800
2	Sensor 2 input (Rate of Turn)	Receive only	4800
3	Sensor 3 input (Gyro heading)	Receive only	4800
4	External display / ECDIS	Bi-directional	38400
5	Pilot port	Bi-directional	38400
6	Long Range / Spare*	Bi-directional	38400
7	DGPS beacon receiver / Spare*	Bi-directional	4800

Table 4 Serial data ports

*If the Long Range and DGPS ports are not required for these functions they can be re-assigned to 38400 baud operation for connection of additional display equipment.

All sensor ports can be configured via the sensor configuration menu which can be found under the Main menu>Installation>Sensor configuration menu option.

The sensor configuration menu also includes the ability to disable the requirement for external GPS sensors to provide a DTM sentence, as not all external GPS devices provide this sentence.



If an external GPS device which does not provide a DTM sentence is connected to the transceiver and the transceiver is configured to require DTM sentences, the external GPS data will not be accepted by the transceiver. If no DTM sentence is required the WGS84 datum will be used as a coordinate origin.

4.4.4 Junction box connections

The junction box provides screw terminal connections for each of the seven data ports. The connections and functions of each connection are defined in Table 5. All connections are labeled on the junction box PCB for clarity. A diagram showing connections available inside the junction box is provided in Figure 43.

Use shielded cable when connecting ships sensors and display systems to the junction box, and connect the cable shield to the terminal block marked 'shields' in the junction box. It is possible to remove the PCB from the junction box enclosure to aid connection of cables to the screw terminals during installation.

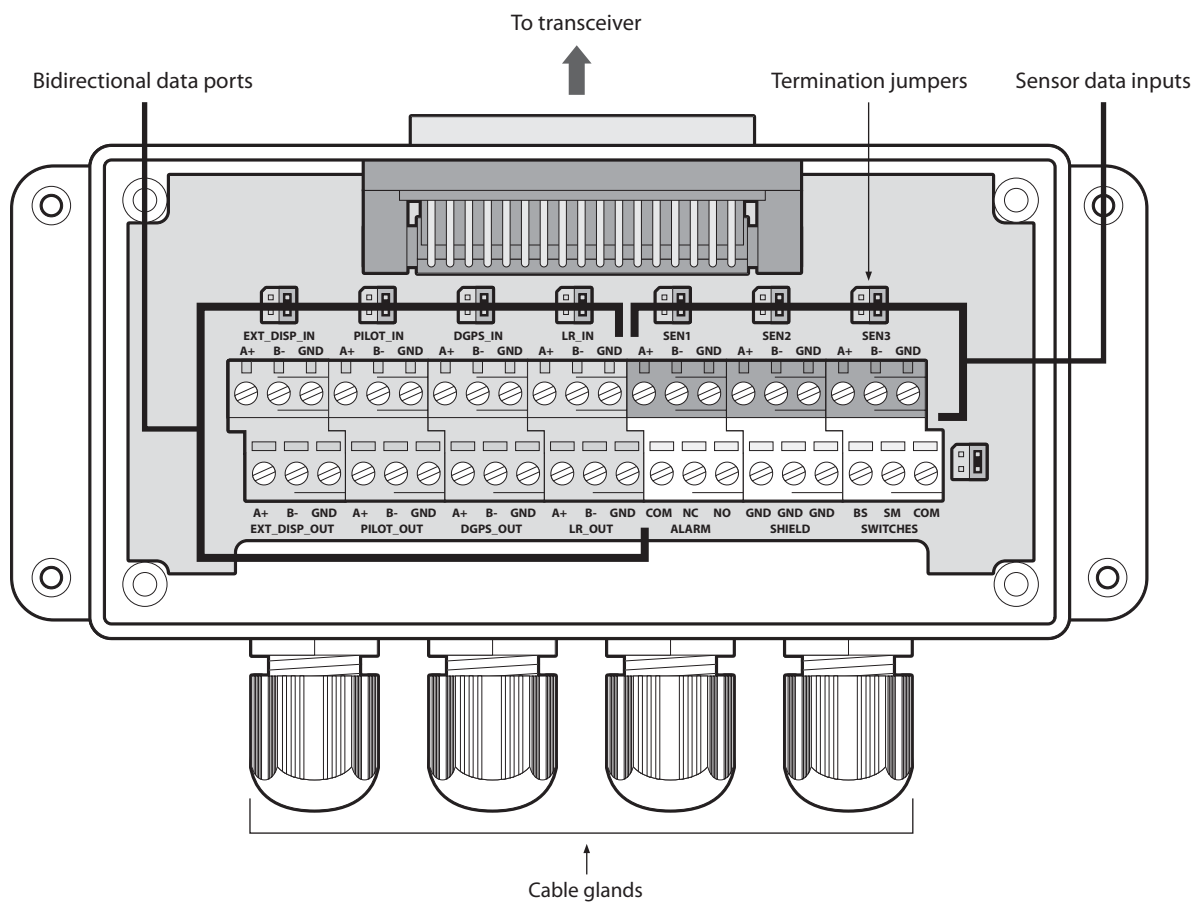

Figure 43 Junction box connections

Data port	Junction box signal label	Description	Function
Sensor 1	SEN1 A+	Sensor port 1 input A	Connect to data source, typically ships primary GPS at 4800baud. This port can be configured to operate at either 4800 or 38400 baud*.
	SEN1 B-	Sensor port 1 input B	
	SEN1 GND	Sensor port 1 isolated ground	
Sensor 2	SEN2 A+	Sensor port 2 input A	Connect to data source, typically gyro or heading. This port can be configured to operate at either 4800 or 38400 baud*.
	SEN2 B-	Sensor port 2 input B	
	SEN2 GND	Sensor port 2 isolated ground	
Sensor 3	SEN3 A+	Sensor port 3 input A	Connect to data source, typically ROT or speed. This port can be configured to operate at either 4800 or 38400 baud*.
	SEN3 B-	Sensor port 3 input B	
	SEN3 GND	Sensor port 3 isolated ground	
External display	EXT_DISP_IN A+	External display input A	Connect to the data output of an external display system, typically an ECDIS. This port operates at 38400 baud.
	EXT_DISP_IN B-	External display input B	
	EXT_DISP_IN GND	External display input ground (isolated)	
	EXT_DISP_OUT A+	External display output A	Connect to the data input of an external display system, typically and ECDIS. This port operates at 38400 baud.
	EXT_DISP_OUT B-	External display output B	
	EXT_DISP_OUT GND	External display output ground	
Pilot	PILOT_IN A+	External display input A	<p>Connections for the pilot port. These connections duplicate the pilot plug on the front panel of the transceiver and can be used to relocate the pilot plug if required.</p> <p>If relocating the pilot plug note that AMP/Receptacle (Square Flanged (-1) or Free-Hanging (-2)), Shell size 11, 9-pin, Std. Sex 206486-1/2 or equivalent with the following terminations must be used.</p> <ul style="list-style-type: none"> - TX A is connected to Pin 1 - TX B is connected to Pin 4 - RX A is connected to Pin 5 - RX B is connected to Pin 6 - Shield is connected to Pin 9
	PILOT_IN B-	External display input B	
	PILOT_IN GND	External display input ground (isolated)	
	PILOT_OUT A+	External display output A	
	PILOT_OUT B-	External display output B	
	PILOT_OUT GND	External display output ground	

Table 5 Serial data port connections

*This setting relates to IEC61162-1 or IEC61162-2 operation. Refer to section 4.4.3 for further information on baud rate configuration.

An example of connection to external display equipment is provide in Figure 44, and connections to other equipment and sensors follow the same scheme. To determine the 'A' and 'B' signal lines on external equipment use a digital volt meter to measure the signal line voltage referenced to ground. If the voltmeter shows a negative voltage the 'A' signal line is being measured, a positive voltage indicates the 'B' signal line.

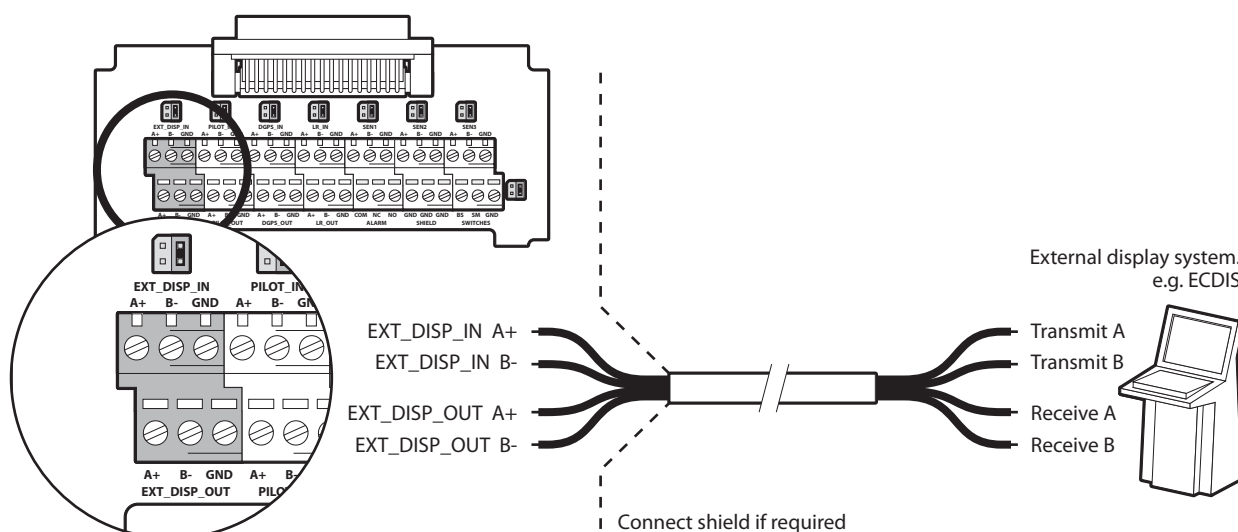

Figure 44 Example connection to external display equipment

The junction box provides jumpers to select alternative line termination configurations for data input connections from remote equipment. The line termination options are:

- None - no line termination, suitable for short cable runs less than 10m (as supplied).
- R - 120 Ohm line termination, suitable for longer cable runs greater than 10m.
- RC - AC 120 Ohm / 1uF termination. Not used.

Select the appropriate line termination option for each data input connection using the jumper adjacent to the data input connection in the junction box. The jumper positions for each termination option are shown in Figure 45.

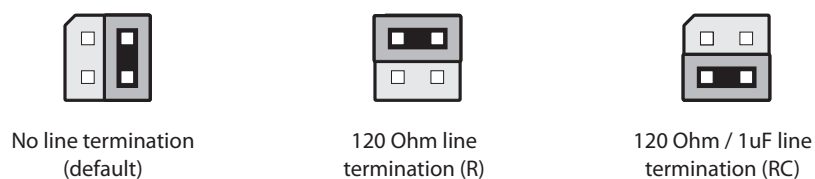

Figure 45 Line termination options

Along with data port connections the junction box also provides connections to the AIS transceiver alarm relay contacts. The common and normally open alarm contacts are duplicates of the alarm relay connections available at the power connector (see Table 6) whilst the normally closed contact is only provided at the junction box. The alarm relay connections are described in Table 6. Use the alarm connections appropriate to the vessels alarm system.

Junction box alarm connection	Function	Contact rating
COM	Alarm relay common connection	220V or 2A or 60W maximum
NC	Alarm relay normally closed connection	
NO	Alarm relay normally open connection	

Table 6 Alarm relay connections

4.4.5 Power and alarm connections

Power is connected to the transceiver via the supplied four way power and alarm cable as shown in Figure 46.

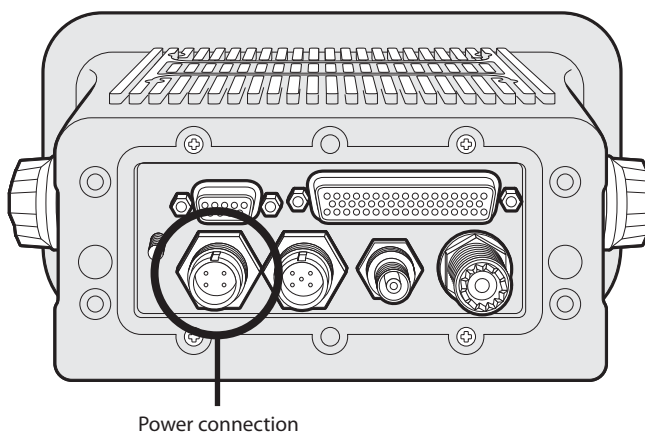

Figure 46 Power connection

The power and alarm cable contains four wires which should be connected according to Table 7.

Wire colour	Function	Connect to
Brown	Power supply +	12V or 24V DC power supply from ships emergency power source*
Black	Power supply -	Power supply ground
White	Alarm relay normally open contact	Bridge alarm system
Blue	Alarm relay common contact	Bridge alarm system

Table 7 Power supply connections

*Connection to an emergency power source is an IMO requirement for SOLAS vessels.

The power supply current ratings and recommended fusing or circuit breaker currents are as follows:

- A 12VDC supply should be able to provide 4.0A and be fused at 8.0A.
- A 24VDC supply should be able to provide 2.0A and should be fused at 4.0A.

The alarm relay is rated to 220VDC or 2ADC or 60W maximum. The alarm connections provided at the power connections are a duplicate of the those available via the junction box and described in section 4.4.

A chassis ground stud is provided on the rear panel of the transceiver. Note that the transceiver chassis is isolated from the incoming power supply so this stud must not be connected to power supply ground.

4.4.6 PC data connection

A 9 way D-type connector is provided on the rear panel of the Poseidon transceiver. This interface allows direct connection to a PC RS232 interface and can be used for installation, diagnostics or external display connection. The default configuration for this interface allows connection of an ECDIS or charting system and duplicates the 'External display' port in the junction box.

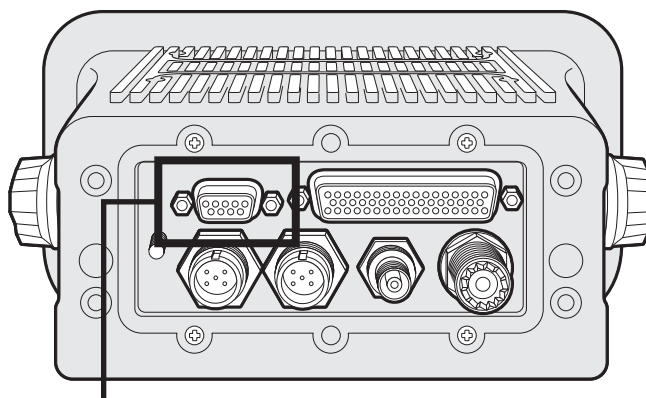

PC data (RS232) connection

Figure 47 PC data (RS232) connection

The pin allocation for the 9 way D-type socket on the rear panel of the transceiver is shown in Table 8.

Transceiver 9 Way D-type pin	Signal	Function
1	No connection	
2	RS232 Transmit	Connect to PC RS232 receive
3	RS232 Receive	Connect to PC RS232 transmit
4	No connection	
5	RS232 Ground	Connect to PC RS232 ground
6	No connection	
7	No connection	
8	No connection	
9	No connection	

Table 8 Pin allocation for the 9 way D-type socket

4.5 Configuring the Poseidon transceiver

Once all connections have been made the transceiver can be powered and configured for operation. During configuration information about the vessel on which the transceiver is installed is entered into the transceiver. It is important this information is entered accurately as it will be broadcast to other AIS equipped vessels and shore stations.

Once configuration is completed the installation record found at the rear of this manual should be completed and retained on board the vessel.

4.5.1 Pre configuration checks

To proceed with configuration the following steps should already have been completed:

- The transceiver is fixed to the vessel
- VHF and GPS antennas have been installed and connected to the transceiver
- The data cable has been connected between the transceiver and junction box
- Ships sensors and AIS enabled display equipment have been connected to the junction box
- Power has been connected to the transceiver and the transceiver is operational (the display is active).

The following configuration instructions assume the installer is familiar with the Poseidon user interface, details of which can be found in the Operation section of this manual.

4.5.2 Configure vessel identification information

The transceiver must be configured with information about the vessel on which it is installed prior to operation. The following information is required:

- MMSI - Vessel MMSI number (Maritime Mobile Service Identity), this can usually be found on the ships VHF radio license and should be the same MMSI as used for the VHF / DSC radio.
- Name - Vessel Name (limited to 20 characters)
- Call sign - Vessel radio call sign (limited to 7 characters)
- IMO No. - Vessels IMO identification number (if applicable)
- Dimensions giving the location of the GNSS antenna connected to the AIS transceiver (Internal GPS)
- Dimensions giving the location of the GNSS antenna connected to any external position source connected to the AIS transceiver

To enter the vessel identification information press the 'Menu' key and select the 'Installation' then 'Set identification' option. You will be prompted to enter a password at this stage, the default password is '000000' (six zeros), for additional information on password entry see section 3.16. The vessels MMSI, Name, Call sign and IMO number can be entered on the screen displayed after successful password entry.

To enter the GNSS antenna locations go back to the main menu and select the 'Dimensions' then 'Internal' or 'External' option as appropriate. Dimensions for both the internal and external GNSS antennas must be entered if an external GNSS is connected to the AIS transceiver. The antenna dimensions should be entered in metres according to the diagram provided in Figure 48.

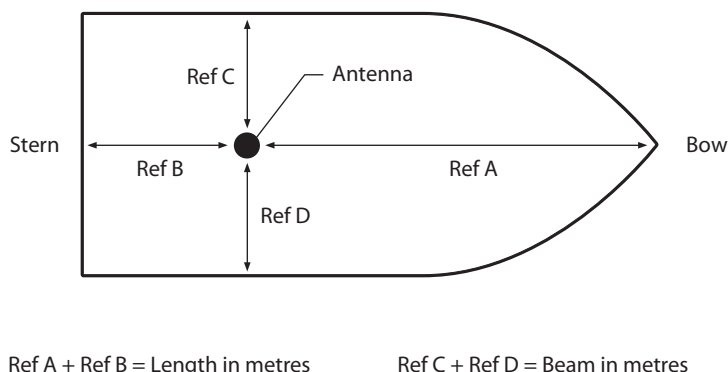

Figure 48 Vessel dimensions measurement

4.5.3 Configure voyage related data

The transceiver must be configured with information about its voyage prior to operation. The following information is required:

- Nav Status - Navigational status selected from the list below:
 - 0 - Under way using engine.
 - 1 - At anchor.
 - 2 - Not under command.
 - 3 - Restricted manoeuvrability.
 - 4 - Constrained by her draught.
 - 5 - Moored.
 - 6 - Aground.
 - 7 - Engaged in fishing.
 - 8 - Under way sailing.
 - 9 to 14 - reserved for future use.
 - 15 - not defined (default setting).
- Destination - Ships next destination port (limited to 20 characters).
- ETA - Estimated time / date of arrival at destination (using UTC time).
- Draught - Maximum present static draught to the nearest 1/10th of a metre.
- Ship and cargo type - a two digit code selected using Table 9. Where the second digit is represented by [n] the appropriate code for the second digit should be selected from Table 10.
- Crew - Number of crew on board (optional).

To enter the vessel identification information press the 'Menu' key and select the 'Voyage Data' option. The vessels Nav. status, Destination, ETA, Draught, Type and number of crew can then be entered.

Vessel type	Type code
Reserved	1[n]
Wing in ground craft	2[n]
Fishing	30
Towing	31
Towing and length of tow exceeds 200m or breadth exceeds 25m	32
Engaged in dredging or underwater operations	33
Engaged in diving operations	34
Engaged in military operations	35
Sailing	36
Pleasure craft	37
(HSC) High speed craft	4[n]
Pilot vessel	50
Search and rescue vessel	51
Tug	52
Port tender	53
Vessel with anti-pollution facilities	54
Law enforcement vessel	55
Spare - for local use	56
Spare - for local use	57
Medical transports (under the 1949 Geneva conventions and additional protocols)	58
Ships according to RR Resolution No. 18 (Mob-83) - Relating to the Procedure for Identifying and Announcing the Position of Ships and Aircraft of States Not Parties to an Armed Conflict	59
Passenger ship	6[n]
Cargo ship	7[n]
Tanker	8[n]
Other type of ship	9[n]

Table 9 Vessel types and their corresponding vessel type codes

Cargo type	Second digit (where not predefined)
All ships of this type	0
Carrying DG, HS, or MP, IMO hazard or pollutant category A	1
Carrying DG, HS, or MP, IMO hazard or pollutant category B	2
Carrying DG, HS, or MP, IMO hazard or pollutant category C	3
Carrying DG, HS, or MP, IMO hazard or pollutant category D	4
Reserved	5
Reserved	6
Reserved	7
Reserved	8
No additional information	9

Table 10 Type codes for vessels carrying cargo

4.6 Changing the password

Following configuration of the transceiver the password should be changed from its default value of '000000' to another six digit code. Password change is carried out by selecting the main menu '*Installation*' menu, then the '*Change password*' submenu.

A prompt for the existing password will be shown, followed by entry of the new password then confirmation of the new password before the new password is stored and active. The password should be recorded on the installation record found in section 9.

4.7 Confirming correct operation

Following entry of the vessel identification and voyage related information the transceiver will commence normal operation. To complete the installation correct operation should be verified as follows:

1. Exit the menu system and return to the main operating screens. Press the '*Screen*' key until the 'Own dynamic data' screen is displayed.
2. Check that the displayed position, course, speed and heading are correct by comparing to the display associated to the connected position and other data sources.
3. Check that the status icon display shows 'OK' and that the 'TX' icon flashes periodically.
4. If the vessel is in an area where other AIS equipped vessels are present press the '*Screen*' key until the '*Target list*' screen is displayed. Check that data from other AIS equipped vessels is displayed.

The Poseidon transceiver is now operational and should remain powered unless authorised by the local maritime authority. The installation record at the rear of this manual should now be completed and left on board the vessel.

4.8 Regional area settings

The transceiver can be manually programmed with regional area settings. These settings control the AIS radio channel and transmission settings within a predefined area. Regional settings can also be remotely configured by the local maritime authority via transmissions from an AIS base station. Manual entry of regional area settings should only be carried out if required by the local maritime authority.

The transceiver can store eight regional area settings including both remote and manual entries.

4.8.1 Creating a new regional area setting

To enter a new regional area setting press the '*Menu*' key and select the '*Installation*' and then the '*Regional areas*' sub-menu. The display now shows a list of the current regional area settings as shown in Figure 49.

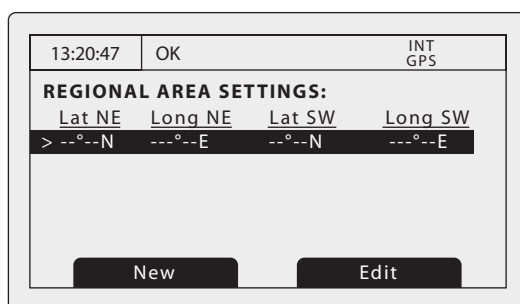

Figure 49 Regional areas list screen

To create the new area setting press now press the 'New' function key and the edit screen shown in Figure 50 will be displayed.

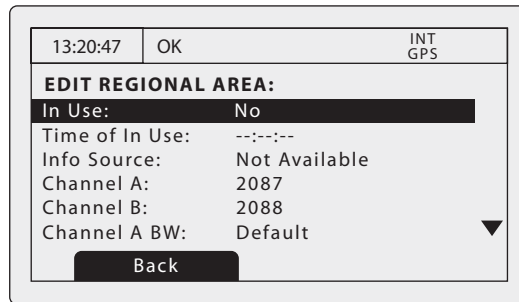

Figure 50 Regional area editing screen

1. The scroll wheel can now be used to scroll to the field to edit.
2. Select the field by pushing the scroll wheel or pressing the 'Edit' function key.
3. Enter a value, or select from a list of possible values using the scroll wheel.
4. Press the 'OK' or 'Cancel' function key to confirm or cancel the entry.
5. Repeat the process 1 - 4 for each field to be edited.
6. Press the 'Back/Save' function key to save the regional area setting and return to the area settings list
7. You will be prompted to confirm storage of the regional area setting with the display shown in Figure 51.
8. After confirmation of the regional settings the settings are stored and may take effect immediately depending on the location of the vessel.

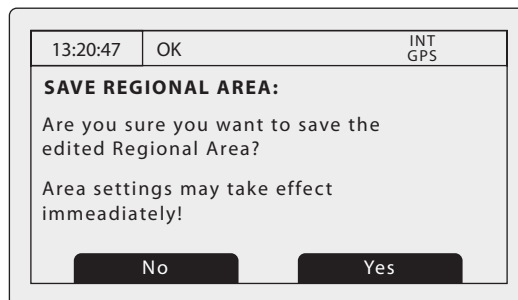

Figure 51 Regional area settings confirmation screen

4.8.2 Editing an existing regional area setting

To edit an existing regional area setting press the 'Menu' key and select the 'Installation' and then the 'Regional areas' sub-menu. The display now shows a list of the current regional area settings as shown in Figure 49. Use the scroll wheel to scroll to and select the regional area setting entry to be edited, then follow the instructions for creating a new regional area setting in section 4.8.1.

4.9 Inland AIS

The Poseidon AIS transceiver supports both Class A (high seas / SOLAS) AIS operation and Inland AIS operation. Switching between Class A and Inland AIS is possible via the menu system and this setting should be made at installation depending on the environment the vessel operates in. Additional vessel and voyage information is required for transmission when operating in Inland AIS mode and this should be configured as described in the following sections.



The transceiver stores Class A (high seas) and Inland AIS vessel and voyage data separately so two independent configurations are required, one for Class A and one for Inland AIS. If the transceiver is being installed on board an Inland vessel then the standard vessel and voyage data configuration should be carried out prior to the additional Inland configuration described below.

4.9.1 Switching between 'Class A' and 'Inland AIS' modes

To switch between operating modes press the '*Menu*' key and select the '*Installation*' sub menu followed by the '*Inland configuration*' then the '*Inland AIS Enable / Disable*' option. When the transceiver is configured to operate in Inland AIS mode the 'IL' icon is shown permanently in the status bar.

- Use the scroll wheel to select either '*Enable Inland AIS*' or '*Disable Inland AIS*' and push to select.
- A prompt will now appear to confirm selection of the change in operating mode which will take immediate effect.
- Confirm the change in operating mode by pressing the '*Yes*' function key.

4.9.2 Entering Inland vessel identification settings

Additional vessel identification information is required for Inland operation along with some changes to the standard AIS configuration. The following additional information must be entered into the AIS transceiver:

- The vessels ENI (unique European Identifier) - this is an 8 digit number allocated to the vessel.
- The ship type as an ERI code (4 digits) selected from the table provided in section .
- The length of the ship to the nearest 10cm (greater accuracy than standard AIS configuration)
- The beam of the ship to the nearest 10cm (greater accuracy than standard AIS configuration)
- A quality setting for the speed, course and heading data sources connected to the AIS is required. The quality setting can be 'high' or 'low' for each data source. The low setting should be used unless a type approved sensor (e.g., a gyro providing heading information) is connected to the AIS transceiver.

The additional identification information can be entered via the main menu. Press the '*Menu*' key then navigate through the '*Installation*', '*Inland AIS*' submenus to select the '*Inland vessel data*' menu. This screen allows entry of the Inland specific information described above.

The following standard AIS vessel identification information must be updated for Inland AIS:

- The IMO number should be set to '0' or '0000000' for an Inland vessel.
- The Call Sign should be set to the vessel's ATIS code (as programmed into the VHF radio)
- The standard AIS ship type should be set to the most applicable ship type - refer to the ship type table in section .

These updates are all made using the process described in section 4.5.2.



Inland vessel dimensions - the length and beam of the ship are entered to the nearest 10cm when operating in Inland AIS mode. This is in addition to the vessel dimensions derived from the GPS antenna location entered during standard configuration (see section 4.5.2) which is entered in meters. The inland specific length and breadth dimensions should be rounded upwards to the nearest meter when entering the standard configuration. Both sets of dimensions should relate to the maximum rectangular size of the convoy.

4.9.3 Entering inland vessel voyage settings

Additional voyage related information is required for Inland operation along with some changes to the standard AIS configuration. The following additional information must be entered into the AIS transceiver:

- The vessels load status as 'loaded' or 'unloaded'.
- The number of blue cones or blue flag status for the cargo (1, 2 or 3 blue cones, or blue flag).
- The static draught of the vessel to the nearest centimetre.
- The air draught of the vessel to the nearest centimetre.
- The number of crew, passengers and other shipboard personnel.
- The number of assisting tugboats (from 0 to 6).

The additional identification information can be entered via the main menu. Press the '*Menu*' key then select the 'Voyage data' sub-menu. When the AIS transceiver is operating in Inland AIS mode the voyage data entry screen will be extended to allow input of the additional information described above.

The following standard AIS voyage information must be updated for Inland AIS:

- Destination

The voyage destination should be entered using UN terminal location codes and ERI terminal codes where possible.

4.9.4 Other Inland AIS settings

When operating in Inland mode it is possible to connect a 'blue sign' switch to the AIS transceiver and also to manually configure the AIS position reporting rate. The connection of the blue sign switch is described in section 4.9.5.

Settings for the blue sign switch and reporting rate are available via the main menu by selecting the '*Installation*' option followed by the '*Inland configuration*' sub menu.

Select the '*Blue sign settings*' option to set up the blue sign switch. The switch can be set to '*Available*' if a blue sign switch is connected or '*Unavailable*' if no switch is connected.

Select the '*Reporting rate selection*' option to manually adjust the AIS position reporting interval. The available reporting interval settings are:

- Autonomous mode (default).
- Once every 10 minutes.
- Once every 6 minutes.
- Once every 3 minutes.
- Once every minute.
- Once every 30 seconds.
- Once every 15 seconds.
- Once every 10 seconds.
- Once every 5 seconds.
- Once every 2 seconds.
- Next higher reporting rate.
- Next lower reporting rate.



Manual changes to reporting rate should be carried out with care and usually only on instruction from the local authority.

4.9.5 Blue sign switch connection

An external switch can be connected to the AIS transceiver to indicate the blue sign state when in Inland AIS mode. If a blue sign switch is installed then the switch should be set to 'Available' as described in section 4.9.4. The external switch should be of a latching single pole type and is connected to the 'Switches' terminals of the junction box as shown in Figure 52. When the connected switch is made (short circuit) the blue sign status will be set and transmitted accordingly in Inland AIS position reports.

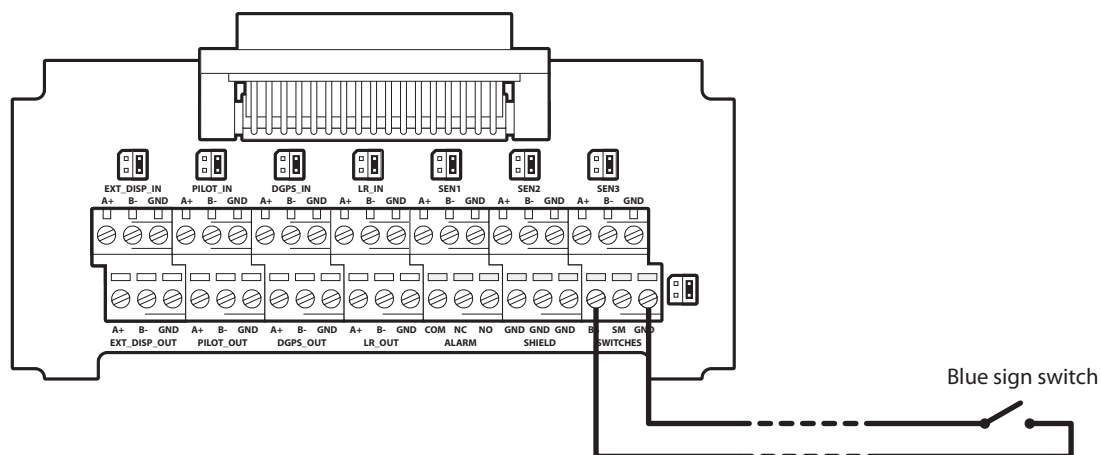

Figure 52 Blue sign switch connection

5 Technical Specifications

5.1 Applicable equipment standards

IEC61993-2 (2001)	Class A shipborne equipment of the universal automatic identification system (AIS) – Operational and performance requirements, methods of test and required test results
IEC60945 (2002)	Maritime navigation and radiocommunication equipment and systems – General requirements – Methods of testing and required test results
IEC61162-1(2008)	Maritime navigation and radiocommunication equipment and systems – Digital interfaces - Single talker and multiple listeners
IEC61162-2 (1998)	Maritime navigation and radiocommunication equipment and systems – Digital interfaces - Single talker and multiple listeners, high speed transmission
ITU-R M.1371-3	Technical characteristics for an automatic identification system using time division multiple access in the VHF maritime mobile band
IEC61108-1(2002)	Global Navigation Satellite Systems (GNSS) – Part 1: Global positioning system (GPS) - Receiver equipment - Performance standards, methods of testing and required test results
CCNR VTT 1.01 (2008)	Central commission for Navigation on the Rhine, Inland AIS Equipment - Vessel Tracking and Tracing Standard for Inland Navigation

5.2 Physical

Transceiver dimensions	210mm x 105mm x 150mm (WxHxD, see 7.1 for drawing)
Transceiver weight	1.5kg
Junction box dimensions	178mm x 76mm x 52mm (see 7.2 for drawing)
Junction box weight	0.35kg
Compass safe distance	300mm (Transceiver)

5.3 Environmental

Operating temperature range	-15°C to +55°C
Maximum operating humidity	90% at +40°C, non-condensing
Water ingress rating	IP52

5.4 Electrical

Supply voltage	12 to 24V DC (absolute min 10.8V, absolute max 31.2 V)
Power consumption	< 12W
Current consumption @12 VDC supply	0.9A typical, 4.0A peak
Current consumption @24 VDC supply	0.5A typical, 2.0A peak

5.5 Display and user interface

Display	248 x 128 pixel monochrome LCD with adjustable backlight
Keypad	Two function keys and two menu keys with adjustable backlight
Rotary control	Encoder with push function and adjustable backlight
Sounder	2.4kHz buzzer

5.6 Internal GPS

Receiver channels	16 channels
Time to first fix	Typically 36 seconds
Frequency	L1 band, 1575.42MHz
Accuracy	2.5m CEP / 5.0m SEP without differential correction 2.0m CEP / 3.0m SEP with SBAS or RTCM DGPS correction
Antenna requirement	Active antenna (5V bias) with gain >15dB

5.7 TDMA transmitter

Frequency range	156.025MHz to 162.025MHz
Channel bandwidth	25kHz
Output power	1W or 12.5W (automatic selection)
Data transmission rate	9600 bits/s
Modulation mode	25kHz GMSK

5.8 TDMA receivers

Number of receivers	2
Frequency range	156.025MHz to 162.025MHz
Channel bandwidth	25kHz
Sensitivity	<-107dBm for 20% PER
Modulation mode	25kHz GMSK
Adjacent channel selectivity	70dB
Spurious response rejection	70dB

5.9 DSC receiver

Number of receivers	1
Frequency	156.525MHz (Channel 70)
Channel bandwidth	25kHz
Sensitivity	-107dBm @ BER 10^{-2}
Modulation mode	25kHz AFSK
Adjacent channel selectivity	70dB
Spurious response rejection	70dB

5.10 RF connections

VHF antenna connection	SO-239 / UHF
VHF port impedance	50 Ohms
GPS antenna connection	TNC female
GPS port impedance	50 Ohms

5.11 Data interfaces

Sensor data input ports	
Number of ports	3
Standard	IEC61162-1
Baud rate	4800 baud
Bidirectional data ports (including pilot port)	
Number of ports	3
Standard	IEC61162-1 / -2
Baud rate	4800 or 38400 baud (default)
Differential correction port	
Standard	ITU 823-2 / RTCM SC-104
Baud rate	9600 baud
RS232 port	
Standard	IEC61162-1 / -2 over RS232
Baud rate	38400 baud

5.12 Power and data connector information

Power connector	LTW BSD-04PMMS-SC7001	Mating half	LTW BSD-04BFFM-SL6A02
Pilot plug connector	TYCO 206486-2	Mating half	TYCO 206485-1
50 way data connector	Harting 09665526612	Mating half	Harting 09670505615
RS232 connector	Harting 09661526612	Mating half	Harting 09670095615

6 Technical reference

6.1 Interface sentences

The IEC61162 sentences accepted by and output by the transceiver serial data ports are listed in Table 11 below.

Data port	Input sentences	Output sentences
Sensor 1 Sensor 2 Sensor 3	DTM, GBS, GGA, GLL, GNS, HDT, RMC, ROT, VBW, VTG	N/A
External display Pilot Long range	ABM, ACA, ACK, AIR, BBM, DTM, GBS, GGA, GLL, GNS, HDT, LRF, LRI, RMC, ROT, SSD, VBW, VSD, VTG	ABK, ACA, ALR, LR1, LR2, LR3, LRF, LRI, TXT, VDM, VDO
DGPS	RTCM SC-104 binary format	RTCM SC-104 binary format
RS232	ABM, ACA, ACK, AIR, BBM, DTM, GBS, GGA, GLL, GNS, HDT, LRF, LRI, RMC, ROT, SSD, VBW, VSD, VTG	ABK, ACA, ALR, LR1, LR2, LR3, LRF, LRI, TXT, VDM, VDO

Table 11 IEC61162 sentences input and output

6.2 Transmission intervals

The IEC61162 sentences are in general output in response to a specific event, such as initiation of a binary message via the user interface. Certain messages are output over the ports at regular transmission intervals. Table 12 lists each sentence type and the transmission interval.

Output sentence type	Transmission interval	Comments
VDO	once a second	Own vessel VDL reports. When a report is not generated by the transceiver a 'dummy' VDO is generated in its place.
ALR (inactive)	once a minute	An ALR sentence for each internal alarm is output as a single block once every minute whilst all alarms are inactive
ALR (active)	once every thirty seconds	Once an alarm becomes active the transmission interval switches to once every thirty seconds. The active alarm is not reported as part of the block of inactive alarms during this period.
ABK, ACA, LR1, LR2, LR3, LRF, LRI, TXT, VDM,RTCM	Only transmitted when specifically initiated by an external event	

Table 12 IEC61162 transmission interval for periodic sentences

6.3 Sensor data input port

The sensor data input port schematic is shown in Figure 53. The optional 120 Ohm termination is selectable via a jumper in the junction box and should be fitted in the 'R' position when long cables connecting to the data source are required - see section 4.4.4. Each sensor data input port is isolated from other data port inputs and from the transceivers internal power supply.

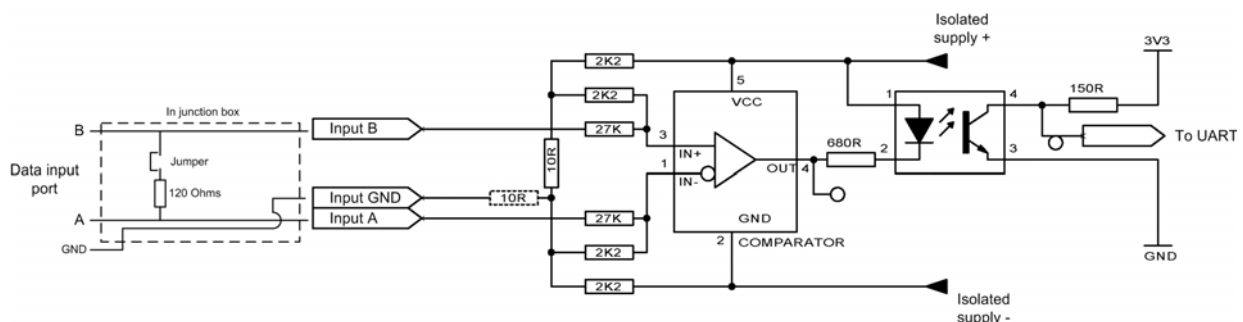

Figure 53 Input port schematic

A logical low input is defined as: $A-B < -0.2V$.

A logical high input is defined as: $A-B > +0.2V$.

The input impedance is approximately 54 kOhms without the junction box jumper fitted, and 120 Ohms with the jumper fitted.

6.4 Bi-directional data ports

The input circuitry of the bi-directional data ports is identical to the input circuitry for the sensor data input ports described in the preceding section. The output circuitry consists of a differential line driver IC (Texas Instruments AM26LV31E) and is shown in Figure 54.

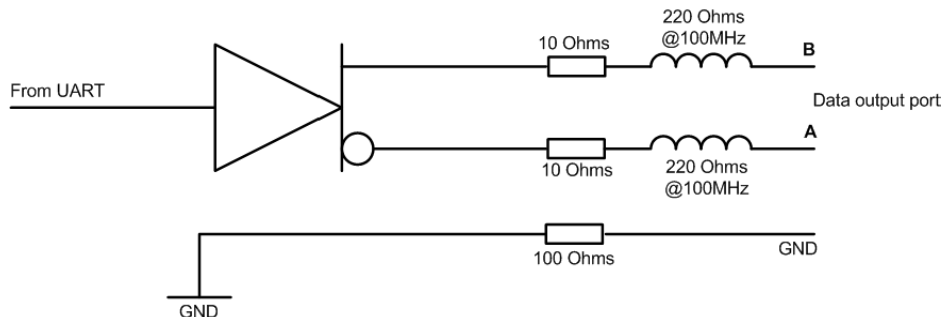

Figure 54 Data output port schematic



Each bi-directional data port input is isolated from other data port inputs and from the transceivers internal power supply. The bi-directional data port outputs are not isolated from each other or the transceivers internal power supply. The transceivers internal power supply is fully isolated from the external supply.

6.5 Output drive capability of bi-directional ports

Bi-directional ports can supply an output current of up to 30mA. The output voltages are 0 (low) and 3.3V (high). Effective load resistance should be in excess of 100Ohms.

6.6 DGPS port

The DPGS correction port is intended for connection to a DGPS beacon receiver. The port has the same physical characteristics as the bi-directional data ports as described in the preceding sections. If connection of a beacon receiver is not required this port can be re-configured as an additional bi-directional port to IEC61162-2. See section 3.17 for port configuration options.

6.7 RS232 port

The RS232 port carries IEC61162 data via RS232 and is intended for connection to a PC during installation and service. The port can also be used to connect to PC based charting applications for display of AIS data.

6.8 Input data sentence formats

All data input is via IEC61162 / NMEA 0183 sentences. The sentences used by the AIS transceiver are documented in the subsequent sections. The sentence structure tables describe each field in the sentence starting from the left most field (field 1) after the sentence identifier. All sentences are terminated with the IEC61162 checksum shown as '*hh'. For details of the checksum calculation please refer to IEC61162-1.

6.8.1 ABM - Addressed binary and safety related message

This sentence allows external applications to transmit binary and safety messages using the AIS transceiver via AIS messages 6 and 12.

!-ABM,x,x,x,xxxxxxxx,x,x.x,s--s,x*hh<CR><LF>		
Field number		Description
1	x =	Total number of sentences needed to transfer the message
2	x =	Sentence number
3	x =	Sequential Message identifier
4	xxxxxxxx =	The MMSI of destination AIS transceiver for the ITU-R M.1371 message
5	x =	AIS channel for broadcast of the radio message
6	x.x =	ITU-R M.1371 message ID
7	s--s =	Encapsulated data
8	x =	Number of fill-bits, 0-5

6.8.2 ACA - AIS regional channel assignment message

This sentence is used to both enter and obtain channel management information.

\$--ACA,x,lll.l,a,yyyy.yy,a,lll.l,a,yyyy.yy,a,x,xxxx,x,xxxx,x,x,x,a,x,hhmmss.ss*hh<CR><LF>		
Field number		Description
1	x =	Sequence Number, 0 to 9
2	lll.l,a =	Region Northeast corner latitude - N/S
3	yyyy.yy,a =	Region Northeast corner longitude - E/W
4	lll.l,a =	Region Southwest corner latitude - N/S
5	yyyy.yy,a =	Region Southwest corner longitude - E/W
6	x =	Transition Zone Size
7	xxxx =	Channel A
8	x =	Channel A bandwidth
9	xxxx =	Channel B
10	x =	Channel B bandwidth
11	x =	Tx/Rx mode control
12	x =	Power level control
13	a =	Information source
14	x =	In-Use Flag
15	hhmmss.ss =	Time of "in-use" change

6.8.3 ACK - Acknowledge alarm

This sentence is used to acknowledge an alarm condition reported by the transceiver.

\$--ACK,xxx,*hh<CR><LF>		
Field number		Description
1	xxx =	Identification number of the alarm source to be acknowledged.

6.8.4 AIR - AIS Interrogation request

This sentence supports ITU-R M.1371 message 15. It provides external applications with the means to initiate requests for specific ITU-R M.1371 messages from remote AIS stations.

\$--AIR,xxxxxxxx,x.x,x.x,x.x,xxxxxxxx,x.x,*hh<CR><LF>		
Field number		Description
1	xxxxxxxx =	MMSI of interrogated station-1
2	x.x =	ITU-R M.1371 message requested from station-1
3	x =	Message sub-section (Reserved for future use)
4	x.x =	Number of second message from station-1
5	x =	Message sub-section (Reserved for future use)
6	xxxxxxxx =	MMSI of interrogated station-2
7	x.x =	Number of message requested from station-2
8	x =	Message sub-section (Reserved for future use)

6.8.5 BBM -Binary broadcast message

This sentence allows generation of ITU-R M.1371 binary broadcast messages (message 8) or broadcast safety related messages (message 14). The content of the message is defined by the application.

!--BBM,x,x,x,x,x,x,s--s,*hh<CR><LF>		
Field number		Description
1	x =	Total number of sentences needed to transfer the message, 1 to 9
2	x =	Sentence number, 1 to 9
3	x =	Sequential message identifier, 0 to 9
4	x =	AIS channel for broadcast of the radio message
5	x.x =	ITU-R M.1371 message ID, 8 or 14
6	s--s =	Encapsulated data
7	x =	Number of fill-bits , 0 to 5

6.8.6 DTM - Datum reference

Logical geodetic datum and datum offsets from a reference datum.

\$--DTM,ccc,a,x.x,a,x.x,a, x.x,ccc*hh<CR><LF>		
Field number		Description
1	ccc =	Local datum
2	a =	Local datum subdivision code - NOT USED
3	x.x, a =	Lat offset, min, N/S - NOT USED
5	x.x,a =	Longitude offset, min, E/W - NOT USED
7	x.x =	Altitude offset, (meter) - NOT USED
8	ccc =	Reference datum

Possible datum and reference datum values are:

- WGS84 = W84
- WGS72 = W72
- SGS85 = S85
- PE90 = P90
- User defined =999 (only available for "Local datum")
- IHO datum code („ -” - „ -” - ” - ” -)

6.8.7 GBS - GNSS satellite fault detection

This sentence is used to support GNSS receiver autonomous integrity monitoring (RAIM). Given that a GNSS receiver is tracking enough satellites to perform integrity checks of the positioning quality of the position solution, a message is needed to report the output of this process to other systems to advise the system user. With the RAIM in the GNSS receiver, the receiver can isolate faults to individual satellites and not use them in its position and velocity calculations. Also, the GNSS receiver can still track the satellite and easily judge when it is back within tolerance.

This sentence shall be used for reporting this RAIM information. To perform this integrity function, the GPS receiver must have at least two observables in addition to the minimum required for navigation. Normally these observables take the form of additional redundant satellites.

\$--GBS, hhmmss.ss, x.x, x.x, x.x, xx, x.x, x.x, x.x *hh <CR><LF>		
Field number		Description
1	hhmmss.ss	UTC time of the GGA or GNS fix associated with this sentence
2	x.x	Expected error in latitude
3	x.x	Expected error in longitude
4	x.x	Expected error in altitude - NOT USED
5	xx	ID number of most likely failed satellite - NOT USED

\$--GBS, hhhmss.ss, x.x, x.x, x.x, xx, x.x, x.x, x.x *hh <CR><LF>		
6	x.x	Probability of missed detection for most likely failed satellite - NOT USED
7	x.x	Estimate of bias on most likely failed satellite - NOT USED
8	x.x	Standard deviation of bias estimate - NOT USED

6.8.8 GGA - Global positioning system (GPS) fix data

This sentence provides time, position and fix related data from a GPS receiver.

\$--GGA, hhhmss.ss, llll.ll, a, yyyy.yy, a, x, xx, x.x, x.x, M, x.x, M, x.x, xxxx*hh<CR><LF>		
Field number		Description
1	hhmmss.ss	UTC time of position fix
2	llll.ll, a	Latitude N/S
3	yyyy.yy, a	Longitude E/W
4	x	GPS quality indicator
5	xx	No. of satellites in use, 00-12 - NOT USED
6	x.x	Horizontal dilution of precision - NOT USED
7	x.x	Antenna altitude above/below mean sea level (geoid) - NOT USED
8	M	Units of antenna altitude, m - NOT USED
9	x.x	Geoidal separation - NOT USED
10	M	Units of geoidal separation, m - NOT USED
11	x.x	Age of diff. GPS data - NOT USED
12	xxxx	Differential reference station ID 0000-1023 - NOT USED

6.8.9 GLL - Geographic position, latitude and longitude

This sentence provides the latitude and longitude for vessel position along with fix time and status.

\$--GLL, llll.ll, a, yyyy.yy, a, hhhmss.ss, A, a *hh<CR><LF>		
Field number		Description
1	llll.ll, a	Latitude, N/S
2	yyyy.yy, a	Longitude , E/W

\$--GLL, llll.ll, a, yyyy.yy, a, hhmmss.ss, A, a *hh<CR><LF>		
3	hhmmss.ss	Time of position (UTC)
4	A	Status: A = data valid V = data invalid
5	a	Mode indicator: A = Autonomous D = Differential E = Estimated (dead reckoning) M = Manual input S = Simulator N = Data not valid

6.8.10 GNS - GNSS fix data

This sentence provides fix data for a single or combined satellite navigation system. The sentence provides data for GPS, GLONASS and possible future satellite systems and combinations thereof.

\$-- GNS, hhmmss.ss, llll.ll, a, yyyy.yy, a, c--c,xx,x.x,x.x,x.x,x.x,x.x *hh<CR><LF>		
Field number		Description
1	hhmmss.ss	Time of position (UTC)
2	llll.ll, a	Latitude N/S
3	yyyy.yy, a	Longitude E/W
4	c--c	Mode indicator
5	xx	Number of satellites in use, 00-99 - NOT USED
6	x.x	Horizontal dilution of precision (HDOP) - NOT USED
7	x.x	Antenna altitude, m, above mean-sea-level - NOT USED
8	x.x	Geoidal separation, m - NOT USED
9	x.x	Age of differential data - NOT USED
10	x.x	Differential reference station ID - NOT USED

6.8.11 HDT - Heading, true

Actual vessel heading in degrees produced by a true heading system or device.

\$--HDT, x.x, T*hh<CR><LF>		
Field number		Description
1	x.x, T	Heading, degrees true

6.8.12 LRF - Long range function

This sentence is used in long range interrogation requests and interrogation replies.

\$-LRF,x,xxxxxxxx,c--c,c--c,c--c*hh<CR><LF>		
Field number		Description
1	x	Sequence number , 0 to 9
2	xxxxxxxx	MMSI of requestor
3	c--c	Name of requestor, 1 to 20 character string
4	c--c	Function request, 1 to 26 characters from: A = Ship's name, call sign and IMO number B = Date and time of message composition C = Position E = Course over ground F = Speed over ground I = Destination and ETA O = Draught P = Ship / Cargo type U = Ship's length, breadth and type W = Persons on board
5	c--c	Function reply status: 2 = Information available and provided in the following LR1, LR2, or LR3 sentence 3 = Information not available from AIS transceiver 4 = Information is available but not provided (i.e. restricted access determined by ship's master)

6.8.13 LRI - Long range interrogation

The long-range interrogation of the AIS is accomplished through the use of two sentences. The pair of interrogation sentences, a LRI-sentence followed by a LRF-sentence, provides the information needed by an AIS to determine if it must construct and provide the reply sentences (LRF, LR1, LR2, and LR3).

\$-LRI,x,a,xxxxxxxx,xxxxxxxx,IIII.II,a,yyyyy.yy,a,IIII.II,a,yyyyy.yy,a*hh<CR><LF>		
Field number		Description
1	x	Sequence number, 0-9
2	a	Control Flag
3	xxxxxxxx	MMSI of "requestor"
4	xxxxxxxx	MMSI of "destination"
5	IIII.II,a	Latitude - N/S
6	yyyyy.yy,a	Longitude - E/W (north-east co-ordinate)
7	IIII.II,a	Latitude - N/S
8	yyyyy.yy,a	Longitude - E/W (south-west co-ordinate)

6.8.14 RMC - Recommended minimum specific GNSS data

Time, date, position, course and speed information provided by a GNSS receiver. All data fields should be provided and null fields only used when data is temporarily unavailable.

\$--RMC, hhmmss.ss, A, llll.ll,a, yyyyy.yy, a, x.x, x.x, xxxxxx, x.x,a, a*hh<CR><LF>		
Field number		Description
1	hhmmss.ss	Time of position fix (UTC)
2	A	Status: A = data valid V = navigation receiver warning
3	llll.ll, a	Latitude, N/S
4	yyyyy.yy, a	Longitude, E/W
5	x.x	Speed over ground, knots
6	x.x	Course over ground, degrees true
7	xxxxxx	Date: dd/mm/yy - NOT USED
8	x.x, a	Magnetic variation, degrees, E/W - NOT USED
10	a	Mode indicator: A = Autonomous mode D = Differential mode E = Estimated (dead reckoning) mode M = Manual input mode S = Simulator mode N = Data not valid

6.8.15 ROT - Rate of turn

This sentence provides rate of turn and direction of turn information.

\$--ROT, x.x, A*hh<CR><LF>		
Field number		Description
1	x.x	Rate of turn, °/min, "-" = bow turns to port
2	A	Status: A = data valid, V = data invalid

6.8.16 SSD - Station static data

This sentence is used to enter static parameters into the ship's AIS transceiver. The parameters in this message provide contents for various ITU-R M.1371 messages.

\$--SSD,c--c,c--c,xxx,xxx,xx,xx,c,aa*hh<CR><LF>		
Field number		Description
1	c--c	Ship's Call Sign, 1 to 7 characters
2	c--c	Ship's Name, 1 to 20 characters
3	xxx	Pos. ref., "A," distance from bow, 0 to 511 metres

\$--SSD,c--c,c--c,xxx,xxx,xx,xx,c,aa*hh<CR><LF>		
4	xxx	Pos. ref., "B," distance from stern, 0 to 511 metres
5	xx	Pos. ref., "C," distance from port beam, 0 to 63 metres
6	xx	Pos. ref., "D," distance from starboard beam, 0 to 63 metres
7	c	DTE indicator flag
8	aa	Source identifier

6.8.17 VBW - Dual ground / water speed

This sentence conveys both water and ground referenced speed data.

\$--VBW, x.x, x.x, A, x.x, x.x, A, x.x, A, x.x, A*hh<CR><LF>		
Field number		Description
1	x.x	Longitudinal water speed, knots - NOT USED
2	x.x	Transverse water speed, knots - NOT USED
3	A	Status: water speed, (A = data valid, V = data invalid) - NOT USED
4	x.x	Longitudinal ground speed, knots
5	x.x	Transverse ground speed, knots
6	A	Status, ground speed, (A = data valid, V = data invalid)
7	x.x	Stern transverse water speed, knots - NOT USED
8	A	Status: stern water speed, (A = data valid, V = data invalid) - NOT USED
9	x.x	Stern transverse ground speed, knots - NOT USED
10	A	Status: stern ground speed, (A = data valid, V = data invalid) - NOT USED

6.8.18 VSD - Voyage static data

This sentence is used to enter information about the ship's voyage.

\$--VSD,x.x,x.x,x.x,c--c,hhmmss.ss,xx,xx,x.x,x.x*hh<CR><LF>		
Field number		Description
1	x.x	Type of ship and cargo category, 0 to 255
2	x.x	Maximum present static draught, 0 to 25,5 metre
3	x.x	Persons on-board, 0 to 8191
4	c--c	Destination, 1-20 characters
5	hhmmss.ss	Estimated time of arrival at destination (UTC)
6	xx	Estimated day of arrival at destination, 00 to 31 (UTC)

\$--VSD,x.x,x.x,x.x,c--c,hhmmss.ss,xx,xx,x.x,x.x*hh<CR><LF>		
7	xx	Estimated month of arrival at destination, 00 to 12 (UTC)
8	x.x	Navigational status, 0 to 15
9	x.x	Regional application flags, 0 to 15

6.8.19 VTG - Course over ground and ground speed

The vessels actual course and speed relative to ground.

\$--VTG, x.x, T, x.x, M, x.x, N, x.x, K,a*hh<CR><LF>		
Field number		Description
1	x.x, T	Course over ground, degrees true
2	x.x, M	Course over ground, degrees magnetic - NOT USED
3	x.x, N	Speed over ground, knots
4	x.x, K	Speed over ground, km/h
5	a	Mode indicator: A = Autonomous mode D = Differential mode E = Estimated (dead reckoning) mode M = Manual input mode S = Simulator mode N = Data not valid

6.9 Output data sentence formats

All data output is via IEC61162 / NMEA 0183 sentences. The sentences used by the AIS transceiver are documented in the subsequent sections. The sentence structure tables describe each field in the sentence starting from the left most field (field 1) after the sentence identifier. All sentences are terminated with the IEC61162 checksum shown as '*hh'. For details of the checksum calculation please refer to IEC61162-1.

All sentences start with the delimiter "\$" or "!" followed by the talker equipment type identifier. The identifier for AIS is "AI", e.g., "AIABK".

6.9.1 ABK - Addressed and binary broadcast acknowledgement

The ABK sentence is generated when a transaction, initiated by reception of an ABM, AIR, or BBM sentence is completed or terminated.

\$--ABK,xxxxxxxx,a,x.x,x,x*hh<CR><LF>		
Field number		Description
1	xxxxxxxx	MMSI of the addressed destination AIS transceiver
2	a	AIS channel of reception
3	x.x	ITU-R M.1371 message ID
4	x	Message Sequence Number
5	x	Type of acknowledgement

6.9.2 ACA - AIS Channel assignment message

See section 6.8.2.

6.9.3 ALR - Set alarm state

This sentence is used to indicate local alarm conditions and status along with alarm acknowledgement status.

\$--ALR,hhmmss.ss,xxx,A, A,c--c*hh<CR><LF>		
Field number		Description
1	hhmmss.ss	Time of alarm condition change, UTC
2	xxx	Local alarm number (identifier)
3	A	Alarm condition (A = threshold exceeded, V = not exceeded)
4	A	Alarm's acknowledge state, A = acknowledged , V = unacknowledged
5	c--c	Alarm's description text

6.9.4 LRF - AIS long range function

See section 6.8.12.

6.9.5 LR1 - Long range reply with destination for function request 'A'

The LR1 sentence identifies the destination for the reply and contains information requested by the 'A' function character.

\$--LR1,x,xxxxxxxx,xxxxxxxx,c--c,c--c,xxxxxxxx*hh<CR><LF>		
Field number		Description
1	x	Sequence Number, 0 to 9
2	xxxxxxxx	MMSI of responder
3	xxxxxxxx	MMSI of requestor (reply destination)
4	c--c	Ship's name, 1 to 20 characters
5	c--c	Call Sign, 1 to 7 characters
6	xxxxxxxx	IMO Number, 9-digit number

6.9.6 LR2 - Long range reply for function requests 'B', 'C', 'E' and 'F'

The LR2 sentence contains the information requested by the B, C, E and F function characters.

\$--LR2,x,xxxxxxxx,xxxxxxxx,hhmmss.ss,llll.ll,a,yyyyy.yy,a,x.x,T,x.x,N*hh<CR><LF>		
Field number		Description
1	x	Sequence Number, 0 to 9
2	xxxxxxxx	MMSI of responder
3	xxxxxxxx	Date: ddmmyyyy, 8 digits

\$--LR2,x,xxxxxxxx,xxxxxxxx,hhmmss.ss,llll.ll,a,yyyyy.yy,a,x.x,T,x.x,N*hh<CR><LF>		
4	hhmmss.ss	Time of position, UTC
5	llll.ll,a	Latitude, N/S
6	yyyyy.yy,a	Longitude, E/W
7	x.x,T	Course over ground, degrees True
8	x.x,N	Speed over ground, knots

6.9.7 LR3 - Long range reply for function requests 'I', 'O', 'P', 'U', and 'W'

The LR3 sentence contains the information requested by the I, O, P, U and W function characters.

\$--LR3,x,xxxxxxxx,c--c,xxxxxx,hhmmss.ss,x.x,cc,x.x,x.x,x.x,x.x*hh<CR><LF>		
Field number		Description
1	x	Sequence Number, 0 to 9
2	xxxxxxxx	MMSI of "responder"
3	c--c	Voyage destination, 1 to 20 characters
4	xxxxxx	ETA Date: ddmmyy
5	hhmmss.ss	ETA Time, value to nearest second
6	x.x	Draught, value to 0,1 metre
7	cc	Ship/cargo (ITU-R M.1371, Table 18)
8	x.x	Ship length, value to nearest metre
9	x.x	Ship breadth, value to nearest metre
10	x.x	Ship type
11	x.x	Persons, 0 to 8191

6.9.8 TXT - Text transmission

For the transmission of short text messages from the AIS equipment. These messages relate to the status of the equipment.

\$--TXT,xx,xx,xx,c--c*hh<CR><LF>		
Field number		Description
1	xx	Total number of messages, 01 to 99
2	xx	Message number, 01 to 99
3	xx	Text identifier, 01-99
4	c--c	Text message, ASCII, up to 61 characters

6.9.9 VDM - VHF data link message

This sentence is used to transfer the contents of a received AIS message (as defined in ITU-R M.1371) as received on the VHF Data Link (VDL) using 6 bit ASCII data encapsulation.

!--VDM,x,x,x,a,s--s,x*hh<CR><LF>		
Field number		Description
1	x	Total number of sentences needed to transfer the message, 1 to 9
2	x	Sentence number, 1 to 9
3	x	Sequential message identifier, 0 to 9
4	a	AIS Channel, "A" or "B"
5	s--s	Encapsulated ITU-R M.1371 radio message
6	x	Number of fill-bits, 0 to 5

6.9.10 VDO - VHF data link own vessel message

This sentence is used to provide the information assembled for broadcast by the AIS transceiver. It uses 6 bit ASCII data encapsulation.

!--VDO,x,x,x,a,s--s,x*hh<CR><LF>		
Field number		Description
1	x	Total number of sentences needed to transfer the message, 1 to 9
2	x	Sentence number, 1 to 9
3	x	Sequential message identifier, 0 to 9
4	a	AIS Channel, "A" or "B"
5	s--s	Encapsulated ITU-R M.1371 radio message
6	x	Number of fill-bits, 0 to 5

7 Drawings

7.1 AIS transceiver overall dimensions

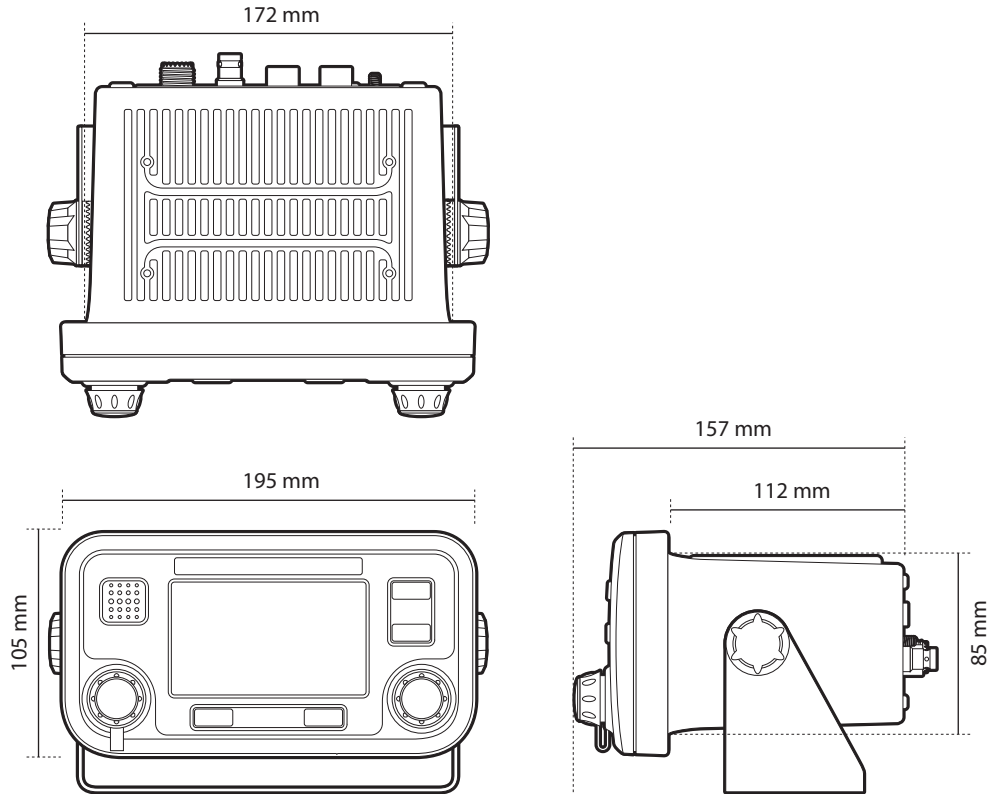

7.2 Junction box overall dimensions

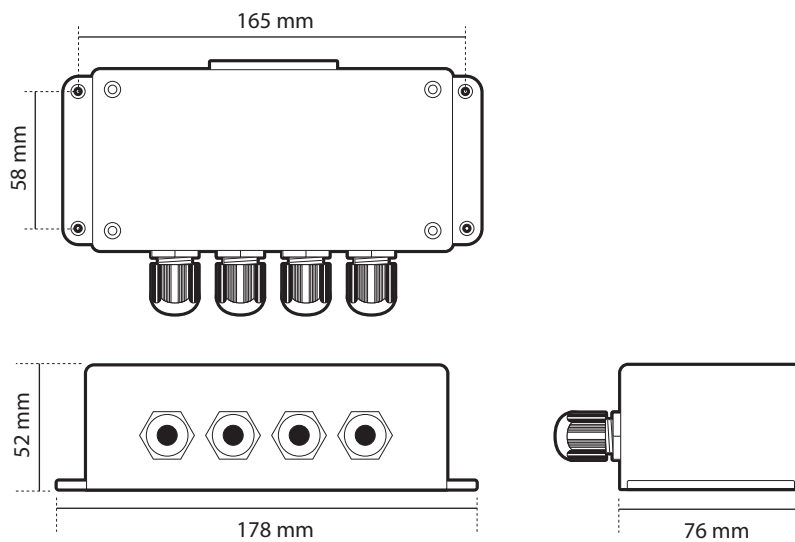

7.3 Dash mount bracket fixing holes (drill drawing) (not to scale)

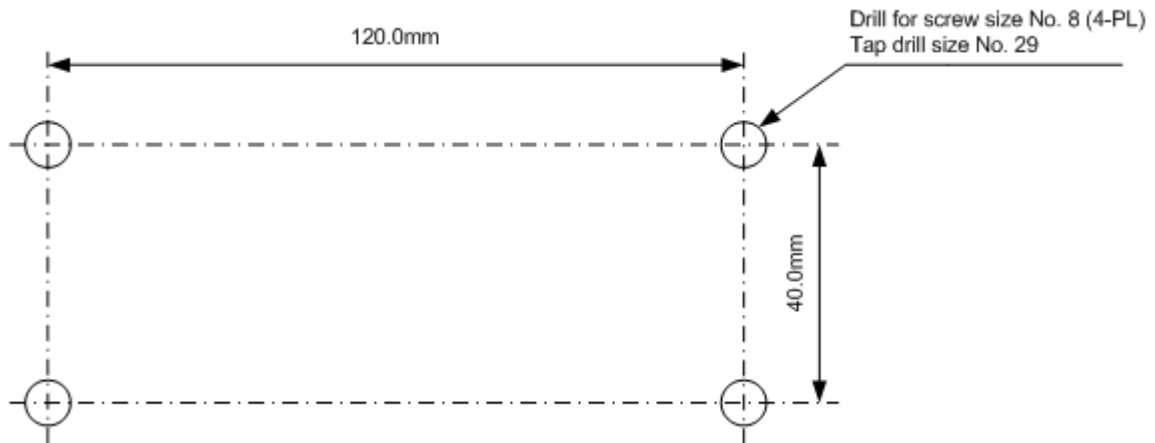

7.4 GPS antenna drawing (not to scale)

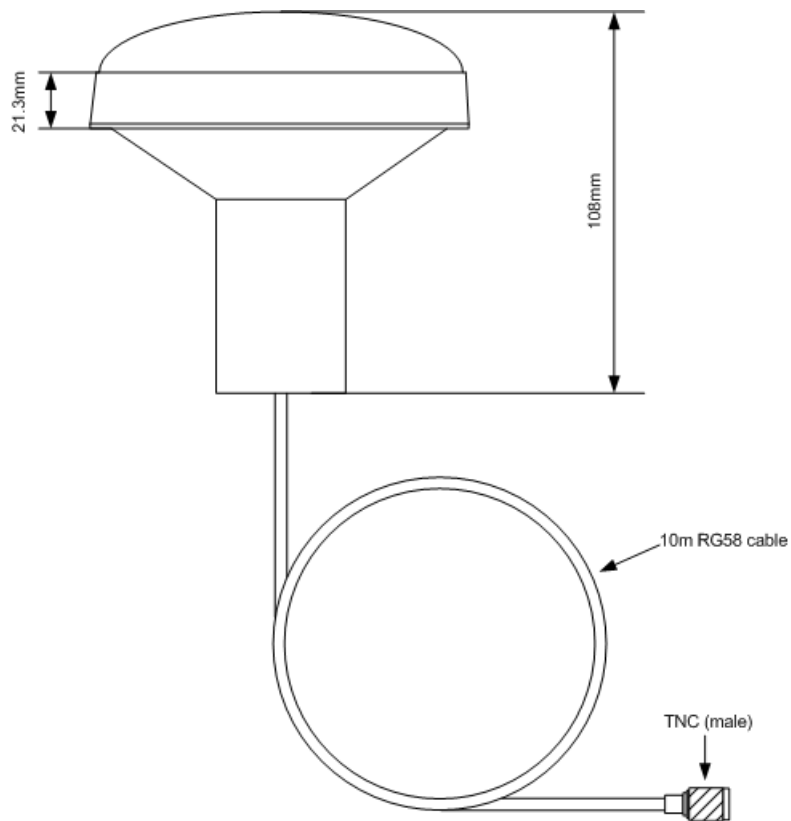

8 Annex A - ERI Ship types

The table below should be used to convert the UN ERI Ship type (used in Inland AIS) to the IMO ship type used in standard AIS operation. ERI ship types are transmitted in Inland AIS message type 10 whereas the ITU vessel type is transmitted in AIS message 5.

ERI Code (Inland AIS)				ITU AIS Vessel type code	
Full code	U	Ship Name (EN)	Vorschlag Via	First digit	Second digit
8000	No	Vessel, type unknown	Unbekannter Schiffstyp	9	9
8010	V	Motor Freighter	Motorgüterschiff (MGS)	7	9
8020	V	Motor tanker	Motortankschiff (MTS)	8	9
8021	V	Motor tanker, liquid cargo, type N	Motortankschiff, Flüssigfracht, Typ N	8	0
8022	V	Motor tanker, liquid cargo, type C	Motortankschiff, Flüssigfracht, Typ C	8	0
8023	V	Motor tanker, dry cargo as if liquid (e.g cement)	Motortankschiff, Trockenfracht	8	9
8030	V	Container Vessel	Containerschiff	7	9
8040	V	Gas tanker	Gas-Tankschiff	8	0
8050	C	Motor freighter, tug	Motorzugschiff	7	9
8060	C	Motor tanker, tug	Motortankzugschiff	8	9
8070	C	Motor freighter with one or more ships alongside	Gekoppelte Fahrzeuge, MGS	7	9
8080	C	Motor freighter with tanker	Gekoppelte Fahrzeuge, mind. 1 MTS	8	9
8090	C	Motor freighter pushing one or more freighters	Schubverband, MGS	7	9
8100	C	Motor freighter pushing at least one tank-ship	Schubverband, mind. 1 TSL	8	9
8110	No	Tug, freighter	Schlepp-Güterschiff	7	9
8120	No	Tug, tanker	Schlepp-Tankschiff	8	9
8130	C	Tug freighter, coupled	Gekoppelte Schlepp-Güterschiffe	3	1
8140	C	Tug, freighter/tanker, coupled	Gekoppeltes Schlepp-Schiff, min. 1 Schl.TS	3	1
8150	V	Freightbarge	Schubleichter (SL)	9	9
8160	V	Tankbarge	Tankschubleichter (TSL)	9	9
8161	V	Tankbarge, liquid cargo, type N	Tankschubleichter, Flüssigfracht Typ N	9	0
8162	V	Tankbarge, liquid cargo, type C	Tankschubleichter, Flüssigfracht, Typ C	9	0
8163	V	Tankbarge, dry cargo as if liquid (e.g cement)	Tankschubleichter, Trockenfracht	9	9
8170	V	Freightbarge with containers	Tankschubleichter mit Containern	8	9
8180	V	Tankbarge, gas	Tankschubleichter für Gas	9	0
8210	C	Push tow, one cargo barge	Motorschubschiff mit 1 SL	7	9
8220	C	Push tow, two cargo barges	Motorschubschiff mit 2 SL	7	9
8230	C	Push tow, three cargo barges	Motorschubschiff mit 3 SL	7	9
8240	C	Push tow, four cargo barges	Motorschubschiff mit 4 SL	7	9
8250	C	Push tow, five cargo barges	Motorschubschiff mit 5 SL	7	9
8260	C	Push tow, six cargo barges	Motorschubschiff mit 6 SL	7	9

8270	C	Pushtow, seven cargo barges	Motorschubschiff mit 7 SL	7	9
8280	C	Pushtow, eight cargo barges	Motorschubschiff mit 8 SL	7	9
8290	C	Pushtow, nine or more barges	Motorschubschiff mit mehr als 8 SL	7	9
8310	C	Pushtow, one tank/gas barge	Motorschubschiff mit 1 TSL	8	0
8320	C	Pushtow, two barges at least one tanker or gas barge	Motorschubschiff mit 2 SL – min.1 TSL	8	0
8330	C	Pushtow, three barges at least one tanker or gas barge	Motorschubschiff mit 3 SL – min.1 TSL	8	0
8340	C	Pushtow, four barges at least one tanker or gas barge	Motorschubschiff mit 4 SL – min.1 TSL	8	0
8350	C	Pushtow, five barges at least one tanker or gas barge	Motorschubschiff mit 5 SL – min. 1 TSL	8	0
8360	C	Pushtow, six barges at least one tanker or gas barge	Motorschubschiff mit 6 SL – min. 1 TSL	8	0
8370	C	Pushtow, seven barges at least one tanker or gas barge	Motorschubschiff mit 7 SL – min. 1 TSL	8	0
8380	C	Pushtow, eight barges at least one tanker or gas barge	Motorschubschiff mit 8 SL – min.1 TSL	8	0
8390	C	Pushtow, nine or more barges at least one tanker or gas barge	Motorschubschiff >8 SL – min.1 TSL	8	0
8400	V	Tug, single	Motorzugschiff	5	2
8410	No	Tug, one or more tows	Motorzugschiff	3	1
8420	C	Tug, assisting a vessel or linked combination	Motorzugschiff assistierend	3	1
8430	V	Pushboat, single	Motorschubschiff	9	9
8440	V	Passenger ship, ferry, cruise ship, red cross ship	Motorfahrgastschiff	6	9
8441	V	Ferry	Fähre	6	9
8442	V	Red cross ship	Krankentransport	5	8
8443	V	Cruise ship	Kabinenschiff	6	9
8444	V	Passenger ship without accomodation	Ausflugsschiff	6	9
8450	V	Service vessel, police patrol, port service	Bundes-, Einsatzfahrzeug	9	9
8460	V	Vessel, work maintainance craft, floating derrick, cable-ship, buoy-ship, dredge	Arbeitsfahrzeug	3	3
8470	C	Object, towed, not otherwise specified	Geschlepptes Objekt	9	9
8480	V	Fishing boat	Fischerboot	3	0
8490	V	Bunkership	Bunkerboot	9	9
8500	V	Barge, tanker, chemical	Tankschubleichter, chemische Stoffe	8	0
8510	C	Object, not otherwise specified	Objekt, nicht näher bezeichnet	9	9
1500	V	General cargo Vessel maritime	Frachtschiff (See)	7	9
1510	V	Unit carrier maritime	Containerschiff (See)	7	9
1520	V	Bulk carrier maritime	Massengutschiff (See)	7	9
1530	V	tanker	Tankschiff (Kein Gas) (See)	8	0
1540	V	Liquified gas tanker	Seegehendes Gas-Tankschiff (See)	8	0
1850	V	Pleasure craft, longer than 20 metres	Sportboot > 20 m (See)	3	7
1900	V	Fast ship	Schnelles Schiff	4	9
1910	V	hydrofoil	Tragflügelboot	4	9

9 Installation record

The following installation record should be completed and retained on board the vessel once the AIS transceiver has been installed and commissioned.

Vessel details

Vessel name			
Flag state			
IMO number		MMSI number	
Owner		Radio call sign	
Type of vessel		Gross registered tonnage	
Length (m)		Beam (m)	
AIS transceiver serial number (see underside of transceiver or packaging label)			
Junction box serial number (see label on junction box)			
Installation password (if changed from default)			
Transceiver software version number			
UI software version number			

GPS / GNSS antenna locations

Internal GPS antenna location (all dimensions in meters, refer to the diagram below)			
A=	B=	C=	D=
External GNSS antenna location (all dimensions in meters, refer to the diagram below)			
A=	B=	C=	D=

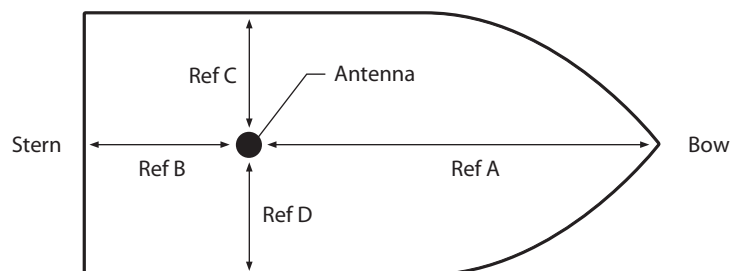

Ref A + Ref B = Length in metres

Ref C + Ref D = Beam in metres

Connected equipment type (where applicable note equipment model and AIS data port in each case)

(D)GPS receiver	
Gyro compass	
ROT indicator	
Speed log	
ECDIS	
Radar	
Other equipment	
Power supply	

The following drawings should be provided and attached to this installation record:

- Antenna layout for VHF and GPS antennas
- AIS arrangement drawing
- Block diagram showing interconnection of equipment

Maintenance record

Modification record number	Details (enter details of modifications to the transceiver including software updates)
1	
2	
3	
4	
5	
6	
8	
9	
10	

Installer detail

Installed by (name)	
Installation company name	
Date of installation	
Vessel location at installation	
Signature	

Installed by (name)	
Installation company name	
Date of installation	
Vessel location at installation	
Signature	

10 Warranty

What this warranty covers

The Manufacturer of this Product warrants to the Buyer that the Product will be free from defects under normal use ("Defects") for a period of two (2) years from the date that the Product was purchased ("Warranty Period").

What this warranty does not cover

The Limited Warranty does not apply to normal wear and tear, does not apply when the Product is opened or repaired by someone not authorised by the Manufacturer and does not cover repair or replacement of any element of the Product damaged by misuse, moisture, exposure to heat, abuse or failure to comply with the instructions supplied with the Product.

How to make a warranty claim

In order to make a claim of a Defect, you must contact the Manufacturer during the Warranty Period to explain the Defect and to obtain an RMA number (Return Materials Authorisation) if necessary. You must return the Product during the Warranty Period (at your own expense), along with an explanation of the Defect, to the address provided to you by the Manufacturer. If the Warranty claim is deemed to be valid the Manufacturer will reimburse to you the cost of shipping and return the Product to you after repair. Your legal rights

This Limited Warranty does not affect any legal rights under applicable national legislation governing the sale of consumer goods. This Limited Warranty cannot be transferred to any other person.

Limitation of liability

The Manufacturer and its suppliers shall not be liable to you or to any third party for any damages either direct, indirect, consequential or otherwise including but not limited to damages for the inability to use the equipment arising out of the use of or inability to use the Product.

The entire liability of the Manufacturer and any of its suppliers shall be limited to the amount actually paid by you for the Product. The provisions of this Limited Warranty are in lieu of any other warranty, whether expressed or implied, written or oral. The Manufacturer and its suppliers shall not be liable for any incidental, indirect, consequential or special (including punitive or multiple) damages, loss of profit, business, contracts, opportunity, goodwill or other similar loss.

Nothing in this Warranty shall limit the liability of the Manufacturer or its suppliers in respect of death or personal injury caused by its negligence, fraud or any other liability which by law cannot be excluded or limited

