

Industrial PDA NAUTIZ X3

User's Manual



The amendments that have been made to the original draft are as follows:

Date	Document type	Person in charge	Description of amendment
Oct. 12, 2010	Draft	Soon kyu Park	First draft drawn up
Oct. 12, 2010	Revised	Soon kyu Park	Miswritten words were corrected
Nov. 22, 2010	Revised	Soon kyu Park	Update to Nautiz X3

Product Notices

2010 by Handheld, Inc. All rights reserved.

No part of this manual can be replicated nor copied by any means – all electronic or mechanical means such as digital media or paper, etc. -- without prior written consent from Handheld. The contents of this manual can be subject to change without prior notice.

Software will be provided literally "as is." All software including firmware, applications, etc. have been appropriately licensed. In regard to all the provided software, Handheld assigns users non-transferable, non-exclusive license. Except for the cases set forth hereunder, a user is not allowed to transfer the license to a third party in the form of sublicense or by other means. All or partial modification, merge, integration of the software except for the cases allowed by the copyright laws are prohibited. Hereby, a user shall agree with not violating the laws regarding decompile, disassembly, decoding, and reverse engineering of all or a part of the licensed software without prior consent from Handheld.

Handheld holds rights to modify the product or software in order to improve the stability, features, and design of the product.

Handheld does not accept any liability whatsoever for any incidental or consequential loss or damage arising from the use of applications, products, circuits or other software mentioned in this manual.

Handheld and its logo and Nautiz and its logo are trademarks. Microsoft, Windows CE, Windows Mobile, Bluetooth, Wi-Fi, GSM, etc. are all the properties of their respective owners.

Handheld, Inc. TM

Nautiz TM

<http://www.Nautiz.com/x3>

Index

- Chapter 1 NAUTIZ X3 Information - 5
 - Information on this manual - 5
 - Precautions for Users - 6
 - Getting Started – 8
 - Unpacking the product - 8
 - Installing the SIM card - 9
 - Installing the main battery - 11
 - MicroSD(Micro Secure Digital) card – 16

- Chapter 2 Using NAUTIZ X3 - 18
 - Overview - 18
 - Resetting NAUTIZ X3 - 33
 - Locking NAUTIZ X3 -34
 - Function buttons - 36
 - Stylus - 37
 - Data entry - 37
 - How to take a picture - 38
 - Video recording – 38

- Chapter 3 Data Capture - 39
 - Overview - 39
 - Laser scanning - 39
 - Image decoding – 40

- Chapter 4 Using the phone - 42
 - Overview - 41
 - Using the phone application - 41
 - Using Speed Dial - 48
 - Managing Call History - 51
 - Switching calls on NAUTIZ X3 - 55
 - Text message – 56

- Chapter 5 Using a GPS Navigation - 59
 - Overview - 59
 - Installing a software - 59
 - Setting up GPS on NAUTIZ X3 - 59
 - Operation – 59

- Chapter 6 Using Bluetooth - 60
 - Overview - 60

- Composition of Bluetooth - 62
- Power states of Bluetooth - 63
- Bluetooth activation - 64
- Available Services - 67
- A2DP/ AVRCP Services – 70

- Chapter 7 Maintenance and Troubleshooting - 71
 - Maintenance - 71
 - Safety instructions on battery - 71
 - Cleaning - 72

Chapter 1 NAUTIZ X3 Information

Information on this manual

The contents of this manual contain the version of Windows Mobile running on NAUTIZ X3.

Caution! The illustrations contained in this manual may be different from actual screens.

Technical Support

If you find any problem in the product, please contact Technical Support Team of Handheld (tel:+82-31-788-5324).

Or you can visit our Q&A bulletin board at our web site (<http://www.Nautiz.com>) for further inquiry.

When you make an inquiry, please have the followings ready:

- Serial number of the product
- Model number
- Supplier information, the user's contacts, and the place where the user works

If a problem reported to the Technical Support Team of Handheld has not resolved, a user may have to send the product to Handheld for services and Handheld doesn't provide the user with a replacement device unless there is a signed agreement between the user and Handheld. Handheld does not accept liability for damages that may result from improper packaging when the user sends the product to Handheld.

If you purchased the product from a supplier of Handheld, please contact the supplier for product support.

1. Precautions for Users

The following is the information for the safety of users and for preventing the product from being damaged. Please read the followings carefully and use the product accordingly.

Power

In the event of abnormal sounds, smells, or smoke, please contact Customer Support after unplugging the product from the power outlet and removing the battery.

Do not touch the power plug with wet hand.

Do not charge the battery while thundering or lightening, and unplug the cradle from the power outlet.

Do not use the device in rainy or wet places.

When the surface of the product is wet, turn off the product and remove the battery from the product, then wipe off water with a cloth or a dry towel before use.

Use the cradle when you charge the battery, if possible.

Installation and storage

Do not store the product inside a car to avoid possible theft.

Keep PDA and its stylus out of the reach of children to avoid injury.

If PDA is not going to be used for prolonged periods of time, insert it into the cradle for continuous power supply.

About using this product

When you use the battery for the first time, please use the battery after being fully charged.

Before resetting the device, please backup programs and data in advance.

Before proceeding with software reset, please backup currently-using programs and data to a safer place. As the saved data will be safe, data or files currently being used may be deleted.

Do not place any heavy object on the product.

Do not use the product in humid or dusty places or near heat sources (heaters, cigarette light)

Be careful neither to drop the product nor to give it an excessive shock.

If the touch screen gets dirty with foreign materials, clean it before use.

When using the touch screen, do not use sharp objects (pens, steel wires, and screwdrivers), and only use the stylus and dedicated accessories coming with the products

Only use the provided batteries, power adapter, and cradle.

In regard to the damages resulting from other software installed by a user after purchasing the product, Handheld shall not warrant the product.

Be careful to prevent the surface of a battery from being in contact with metallic objects.

About communication

Do not use PDA nor make a call while driving a car to avoid an accident.

Do not touch the product or its power plug with wet hand or you may get shocked by electricity.

Turn off the product in aircraft or in hospital. The electromagnetic waves of the product may interfere with electric aviation devices or medical equipments.

Turn off the product in the areas exposed to the risk of explosion. Especially, it is safer to power off the product while gassing up a car.

Be wary of using a headset (earphones). The use of headphones at high volume for prolonged periods of time may impair hearing ability.

If the product has features like laser or flash, do not level them at the eyes of people or animals. In so doing, their sight may be impaired.

Warranty

Please do not arbitrarily attempt to disassemble, repair, and modify the main unit of the product. In such cases, warranty of the product will be invalidated.

1. Getting Started

This chapter will explain each part of the product and its accessories.

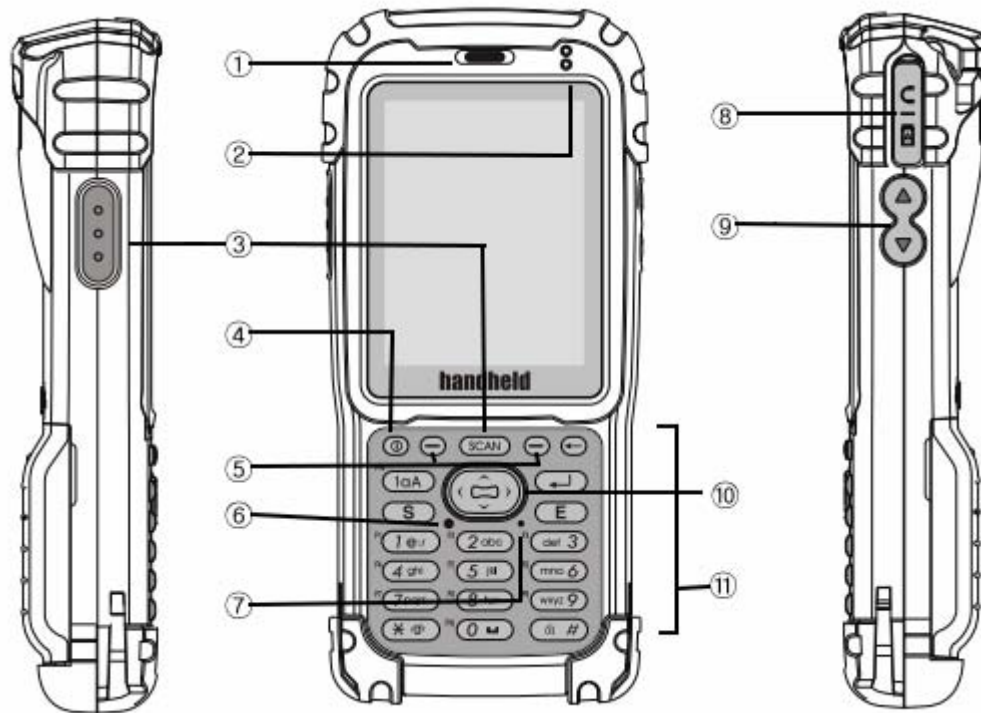

1	Receiver	7	Microphone
2	Indicate LED	8	20Pin Universal Connector
3	Scan Keys	9	Volume Keys
4	Power button	10	Direction Key
5	Windows Mobile Function Keys	11	(←)Backspace, (1aA)Key map Change key S(Send), E(End) Key, (←↵)Enter key numeric Keys
6	Reset button		

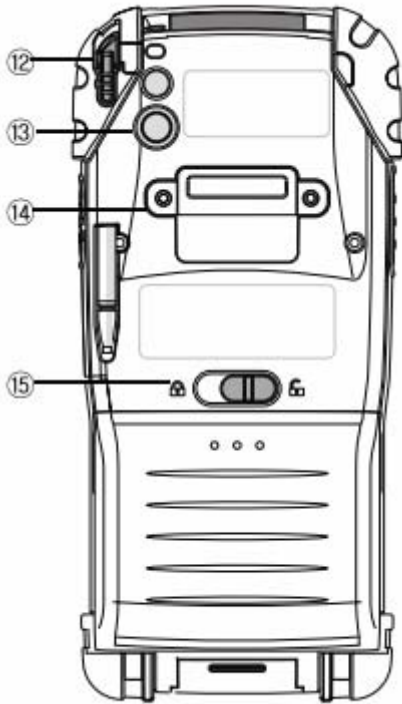

12	Stylus pen and holder	14	Waist strap holder
13	Camera and Camera flash	15	Battery latch

Unpacking the product

Please check whether or not there is any damaged or missing component in the box. If there is any problem, please contact the supplier.

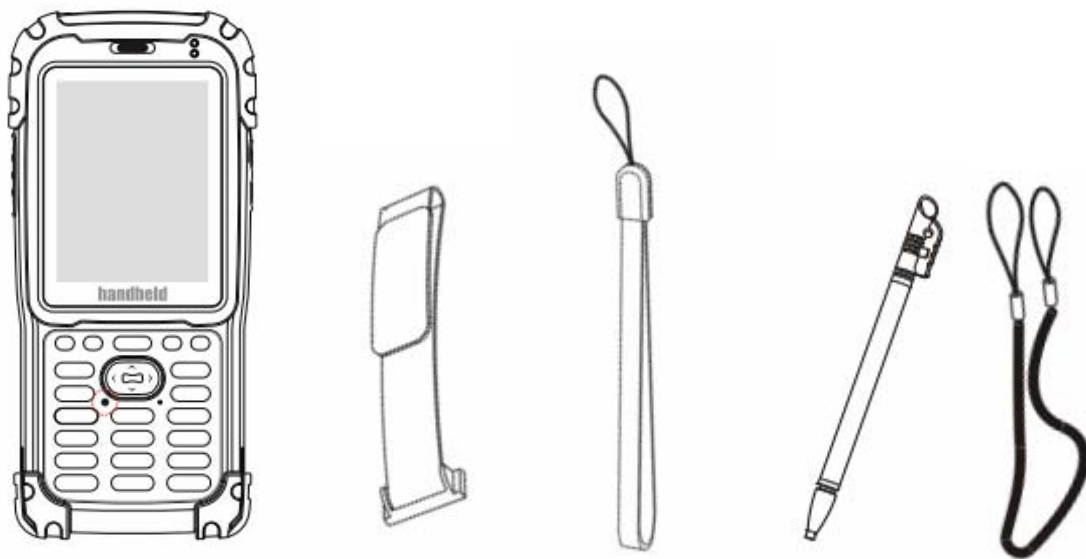

<Main unit of PDA> <Hand strap> <Waist strap> <Stylus and its string >

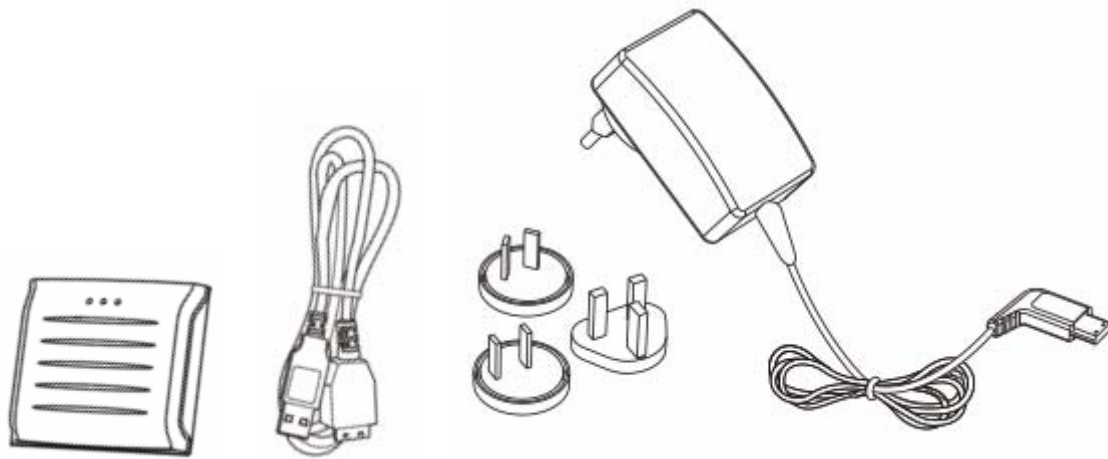

<Li-ion polymer battery> <Data sync cable> <Travel Charger>
<Ear-set: if it has a phone function >

Installing the SIM card

! Please refer to the manual provided by your service provider for further information on SIM card.

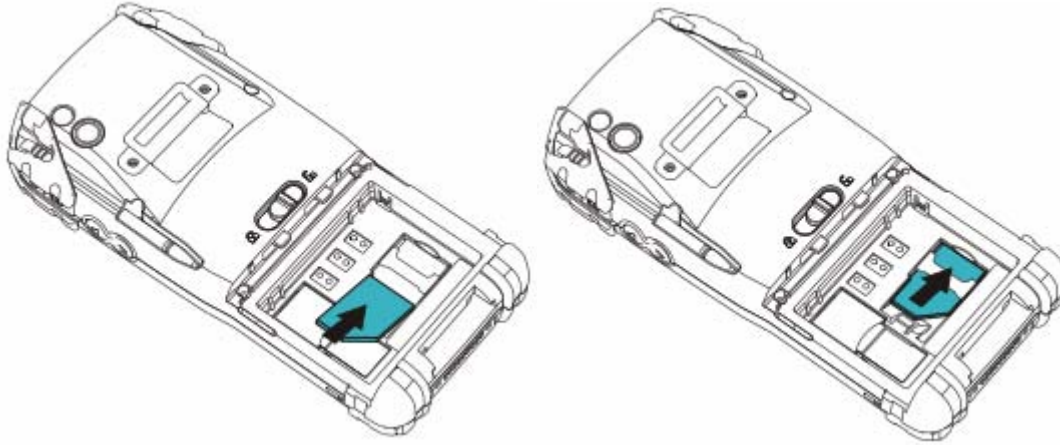

(An illustration of installing a SIM card)

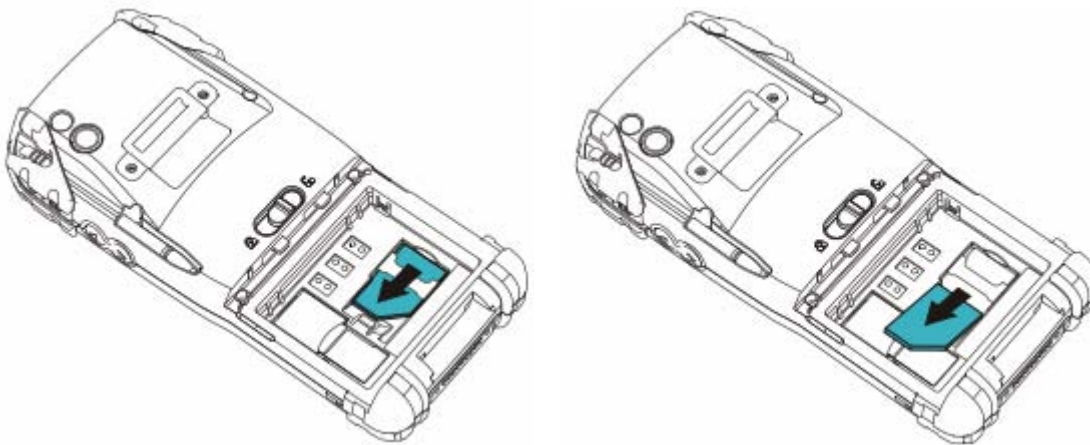

(An illustration of removing a SIM card)

After installing a SIM card for the first time or after replacing it,

1. Turn on the device
2. Press tap on Wireless Manager on Today Screen.
3. Make sure the phone is turned on
4. Make a call for checking cellular connection.

Installing the main battery

Note: One battery comes with the product. You can buy extra battery separately.

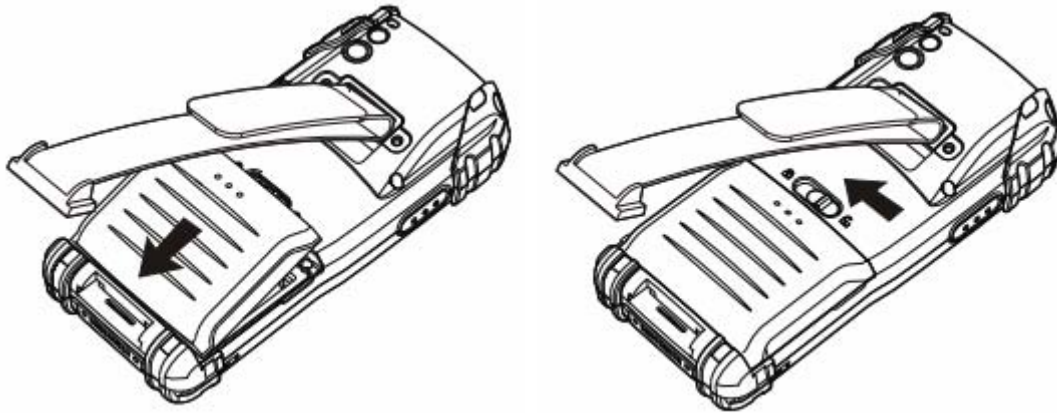

<Inserting the battery>

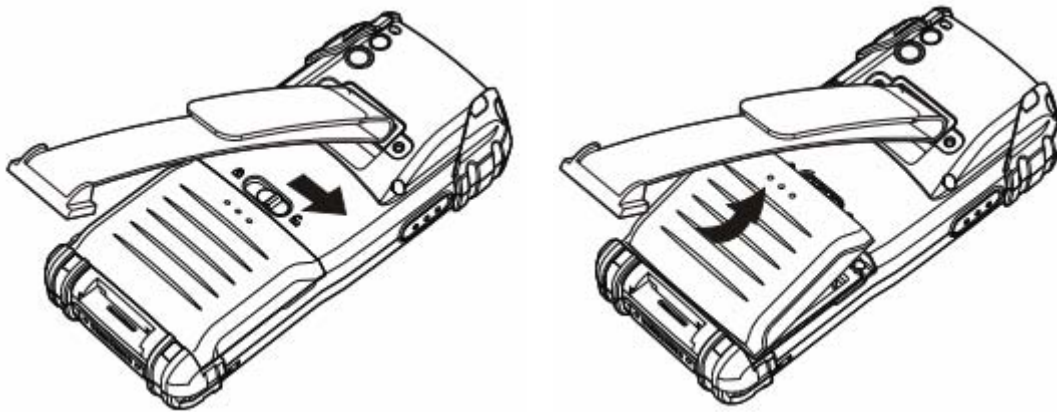

<Removing the battery>

Charging the battery

Before using the battery for the first time, please fully charge the battery until yellow light is on LED, which indicates charging status. Use only the adapter and cable that came with cradle when charging the battery.

In order to charge the backup battery inside the product, we recommend that you charge the battery more than 24 hours before using the product for the first time. Charging may take longer if the battery is installed in a PDA that is turned on.

Charging indicator LED (PDA LED, cradle, etc.)

Charging/battery level indicator LED	Description
Turned off	Unable to charge in PDA / The battery is not properly inserted into the cradle or power is

	off/ The power of the charger or cradle is disconnected.
Red is on	Charging
Red flashes	Charging error – Ambient temperature is too low or too high. Poor contact between the battery and the charging terminals due to foreign materials, etc.
Yellow is on	Charging complete

Caution! : Please charge the battery for more than 24 hours before the first use.

Charging temperature

Charging temperature ranges from 0°C to 40°C (32°F ~ 104°F).

How to check remaining power in the battery

To check the charging status of NAUTIZ X3, tap Start > Settings > Systems > Power and open Power Screen.

Check automatic power-off after a certain period of time by tapping Advanced tab in order to expand battery running time.

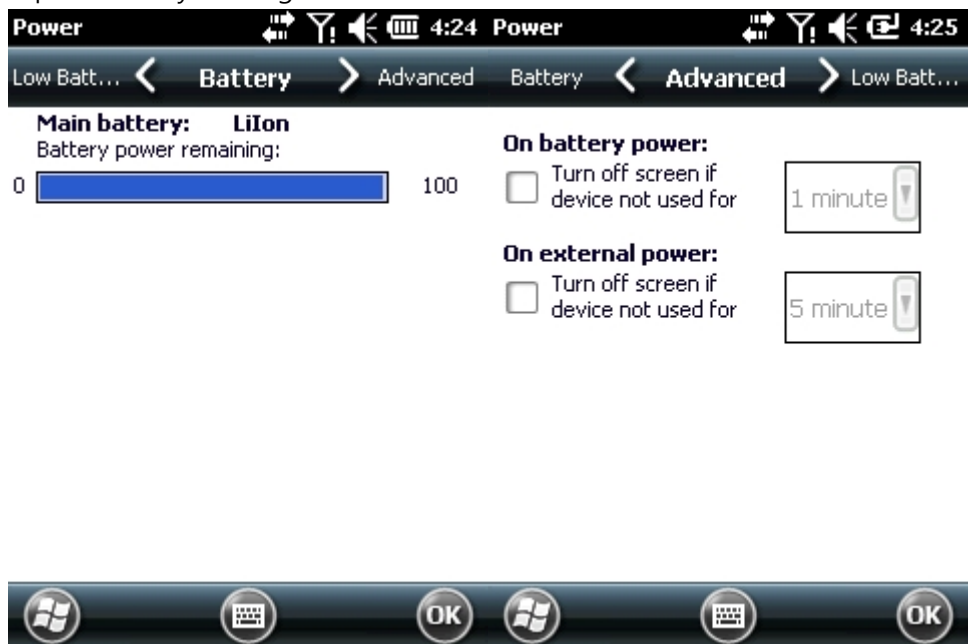

How to take care of the battery

Please follow the battery saving instructions below.

! Note The default settings for WWAN, WLAN and wireless Bluetooth are set at Off.

1. Leave NAUTIZ X3 connected to the power when it is not in use.
2. Set the power to turn itself off when it is not used for a specific time.
3. Set the back light to turn itself off when it is not used for a specific time.
4. Turn off every wireless task when it is not in use.
5. Turn off the power of NAUTIZ X3 to charge at a faster speed.

Changing power settings

How to set NAUTIZ X3 so that it is turned off when it is not used for a specific time

1. Start > Settings > Power icon > Advanced tab
2. On battery power: Turn off screen if device not used for
(When battery power is used: turning off the device when it is not used for the following time period)
Select the X mark and select one of 1 min~5 min from the dropdown menu.
3. Select OK.

Changing backlight settings

How to set NAUTIZ X3 so that only the backlight is turned off when it is not used for a specific time

1. Start > Settings > System > Backlight icon > Battery Power tab
2. On battery power: Disable backlight if device is not used for
(When batter power is used: turning off the backlight when it is not used for the following time period)
Select the X mark and select one of 1 min~5 min from the dropdown menu.
3. Select OK.



Turning off the wireless function

The Microsoft Windows Mobile 6 device includes Wireless Manager which allows every wireless function of the device to be activated, deactivated and composed at one place.

To open Wireless Manager, press Wireless Manager or press Connectivity icon on the Home screen.



<Connectivity icon indicating the part above)

<Wireless Manager captured image>
Select Wireless Manager.

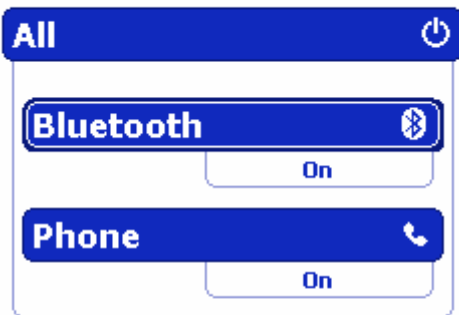

<Wireless Manager Window>

! Note Wireless Connectivity option may differ depending on the composition.

Press specified button to activate or deactivate wireless network.

Press ALL button to activate or deactivate every wireless connection.

Press Menu to compose connectivity settings.

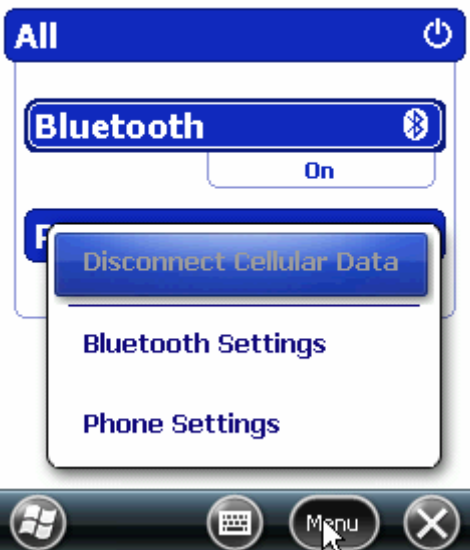

<Wireless Manager menu>

MicroSD(Micro Secure Digital) card

The MicroSD card slot provides an additional saving device function. This slot is located at the bottom of the battery mounting part.

! Warning To prevent MicroSD from damages, be careful about static electricity or other damages. It is recommended to follow the appropriate ESD preventive measures for static electricity.

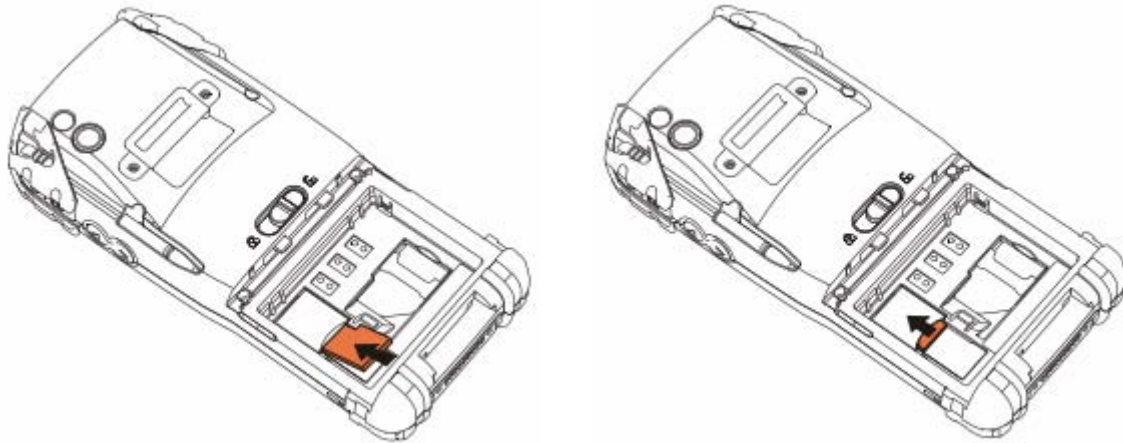

<Installing MicroSD>

Removing MicroSD is in the reverse order.

Adjusting the hand strap

Adjust the hand strap for the convenient use of the device for a long period of time.

1. Connect the hand strap to the end of the device beneath the battery cover.
2. Adjust the length of the hand strap by passing the Velcro through the hole.
3. Press both sides of the strap together to get fixed.

Removing the screen protection cover

The screen protective cover is installed at factory before shipment in order to minimize abrasion that may occur during shipment.

Remove the screen protective cover before use. After removing it, attach protective film to the screen immediately.

Chapter 2 Using NAUTIZ X3

Overview

This chapter will explain how to use the buttons of NAUTIZ X3 and status icons, including the basic instructions on turning on CW 30, resetting, data entry and capture.

The default wireless status of NAUTIZ X3 is as follows:

- Wireless LAN – Off
- Bluetooth – Off
- Phone – Off

Start Screen

The Home Screen is composed of status bar at the top, the Home Screen in the middle, and soft keys at the bottom. The descriptions on those elements are as follows:



Soft key status bar on the Home Screen of application

status bar

(Figure 1) Start Screen of Windows Mobile

Title bar

In the title bar, status-indicating icons may be listed in table 2-1.

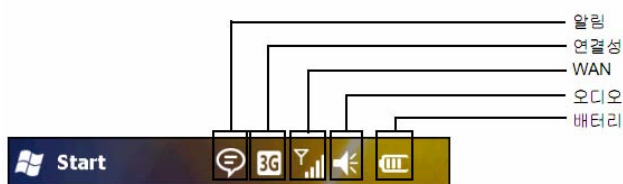

Notification Connectivity WAN Audio Battery

(Figure 2) Title bar

Notifications



The backup battery is low.



Received more than one instant message.



Received more than one email or text message.



Received more than one voice message.



Speakerphone is on.



There are more notifications than indicated. Tapping this icon will display the rest notifications.



Notifications of upcoming appointments

Connectivity



Connected.



Not connected.



Synchronization in progress.



Wi-Fi is available.



Wi-Fi is in use.



HSDPA is available.



3G is available.



GPRS is available.



EGPRS is available.



1XRTT is available.



EVDO is available.



Idling state or no data received during EVDO connection

Status-indicating icons

WAN



There are missed calls.



Dialing without SIM card.



Call is in progress.



Calls are forwarded.



Call on hold



Antenna/Signal icons: Connected to a wireless network and signal strength is okay.



Antenna/Signal icon: Not connected to a wireless network



Antenna/Signal icon: No service or signal search is not available



Connecting to HSDPA.



HSDPA is in use.



Connecting to 3G.



3G is in use.



Connecting to GPRS.



GPRS is in use.



Connecting to EVDO.



EVDO is in use.



Roaming in progress.



No SIM card installed.

Audio



All sound is on



All sound is off



Vibration mode is on

Battery



Main battery charging.



Main battery fully charged



Main battery charged enough

Battery level



Main battery is half full



Main battery is low



Main battery is very low

Home Screen

The Home Screen showing the list of applications and information status indicating bar is scrollable. The application and its additional information are highlighted in Information status bar.

The home screen moves up and down if you scroll the screen up and down while pressing and holding on the screen with your finger. And the information on the selected application will be displayed on the status bar as the names below information status indicating bar moves.



No illustration available

(Figure 2-2) Scrolling the Home Screen up and down with the finger

In addition, you can move your finger up and down by skipping the names of applications while pressing and holding on the information status indicating bar. When you stop holding on your finger on the screen, the information status display bar and the name of the application will be displayed at the center of the screen.



Figure 2-3. Moving information status display bar



Application names

and icons

Figure 2-4. An example of information status display bar

To customize Home Screen, tap Start > Setting > Home icon. You can customize the background of the screen using the Appearance tab and change the screen properties using the Property tab.

Classic Home Screen

You can change the Home Screen into the classic layouts used for Windows Mobile 6.5.



Figure 2-5. Home Screen in classic layout

To change the screen to the classic layouts, go to Start > Setting > Home tab.



Figure 2-6. Setting Home Screen

Uncheck the checkbox that was pre-checked by Windows and select other options. Then press OK.

Note: Task bar is only available in the classic layout.

Soft key indicator bar

The soft key indicator bar is displayed at the bottom of the screen, and there are two post-key buttons. This button shows a user a task and menu depending on situations and can be dynamically changed. For example, the soft key of viewing the list of Contacts is New menu. If a user starts to create a new contact on that screen, that soft key will be changed to Complete and Menu.

Start Screen

The user applications and folders are displayed on the Start Screen. Figure 203 shows basic applications and folders displayed on the Start Screen.

Figure 2-7. Start Screen

Table 2-3. Applications and folders displayed on the Start Screen



Home: Closing Start menu and displaying the Home Screen.



Phone: Making calls, Answering calls, changing calls, and configuring call conference.



Text: Sending and receiving SMS text messages.



E-mail: Sending and receiving emails.



Contacts: Sharing contacts with friends and peers.



Internet Explorer: Browsing web and WAP sites and downloading new programs and files from the Internet.



Calendar: Managing appointments and request meetings.



Settings: Opening the configuration folder. See Configuration Folder in page 10.



Getting Started: Launching Start applications.



Alarms: Setting local time of each country and alarms



Picture & videos: Viewing and managing pictures, animation, gif, and video files.



Windows Media: Playing audio and video files.



Marketplace: Purchasing or downloading applications from the Marketplace. You can reconnect to it after upgrading via the Internet using ActiveSync, if it is your first time use.



Messenger: A mobile version of Windows Live Messenger.

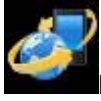

Microsoft My Phone: Synchronizing contacts, appointments, tasks, text messages, music, pictures, videos and documents with a Microsoft My Phone account.



MSN Weather: Checking nearby weather forecast.



Windows Live: If you want to search for information on the web, use the Windows Live™.



MSN Money: Manage finances of a user



Calculator: Performing basic arithmetic calculations including addition, subtraction, multiplication, and division



Game: Launching games.



Notes: Creating handwriting memos or pictures or voice recording files.



Tasks: Managing tasks



Office Mobile: Containing Micro Office application family for mobile devices:

Excel Mobile. OneNote Mobile. PowerPoint Mobile. Word Mobile



File Explorer: Configuring and managing files in the device



Active Sync: Synchronizing information between NAUTIZ X3 and a host computer or Exchange Server



Internet Sharing: Connecting a laptop computer to the Internet using the data connection capability of NAUTIZ X3



Task Manager: Viewing memory usage and CPU allocation status. You can end running processes using this. For further information, please refer to user's manual of Microsoft application for Windows Mobile 6.



Contact Search: Searching for contacts, data, or other information in NAUTIZ X3. For further information, please refer to user's manual of Microsoft applications for Windows Mobile 6.



Help: Displaying online help on the current screen or program.



Keypad: Configuring keypad

Settings folder

Pre-installed configuration applications are listed in Table 2-4. Choose Start > Settings to open Settings folder.

Table 2-4. Configuration applications inside the Settings folder





 **Bluetooth:** Opening Bluetooth applications, setting NAUTIZ X3 to visible mode, and searching for other Bluetooth devices within range.

 **Clock & Alarms:** Setting the clock of device to the date and time of local residence or if you are on travel, you can set them to the corresponding area. You can set alarm for specific date and time.

 **Home:** Customizing the appearance of the Home Screen and displayed information on the screen.

 **Locks:** Setting a password for NAUTIZ X3.

 **Power:** Checking remaining battery power and saving power by setting up the expiry time of display.

 **Sounds & Notifications:** Selecting sounds for various events and alarms and set how to alarm for each event.

 **Connections:** Connection applications are contained (see the below).

 **Personal:** Personal applications are contained (see the below).



System: System applications are contained (see the below).



Microsoft My Phone: Synchronizing contacts, appointments, tasks, text messages, music, pictures, videos and documents with a Microsoft My Phone account.

Connections folder



Beam: A feature related to IrDA (however, it is not supported on NAUTIZ X3)



Connections: In order for the device to connect to the Internet or private local networks by configuring more than of connection types – Dial-up, GPRS, Bluetooth, Modem, etc.



Domain Enroll: For the management and security of a registered device, enroll the device in Active Directory. For further information, refer to user's manual of Microsoft applications for Windows Mobile 6.



USB – PC: Activating or inactivating and enhanced network connection.



Wi-Fi: Configuring a wireless network connection and user-defined settings.



Wireless Manager: Activating or inactivating a wireless connection of NAUTIZ X3 and configuring user-defined Wi-Fi or Bluetooth settings.

Personal folder



 **Buttons:** Allocating a program to a button. Configuring the options of how to input.

 **Owner Information:** Entering NAUTIZ X3 owner's information.

 **Phone:** Configuring phone settings.

System folder



 **About:** Viewing the basic system information such as the version of Windows Mobile R, the type of processor used for NAUTIZ X3, etc.

Backlight: Setting the expiry time of display backlight and adjusting brightness.

Barcode: Setting Barcode message modes, gun modes, decoding sounds, etc.

 **Certificates:** Verifying the certificate information installed in NAUTIZ X3.

 **Customer Feedback:** Submitting a user's comment on Windows Mobile 6 software.

Device Profile: Verifying the build information of NAUTIZ X3 and the other module information.

 **Encryption:** Encrypting files in a storage card. The encrypted files can be only read on this device.

 **Error Reporting:** Activating and inactivating the error reporting feature of the device. Once this function is activated, any occurrence of error will be recorded in a text file including the status of the program and the computer, and if a user wants, it will be reported to Technical Support Team at Microsoft.

 **External GPS:** Configuring an appropriate GPS communication port, if necessary. If there is any program accessing GPS data in the device, or in case of connecting GPS receiver to the device, you have to perform this task in advance.



Keypad: Configuring keypad shortcuts and key maps.

 **Managed Programs:** Displaying installed applications in NAUTIZ X3 using Mobile Device Manager.

 **Memory:** Checking memory allocation status and memory card information; aborting currently-running programs.

 **Regional Settings:** Configuring NAUTIZ X3 locale settings according to each region including how to display numbers, currencies, date/time, or time format.

 **Remove Programs:** Removing programs installed in NAUTIZ X3.

 **Screen:** Changing display direction; compensating for the display after the change; changing

text size.

 **Task Manager:** Stopping running programs.

 **USB Connections:** Configuring how to operate when establishing a USB connection.

 **System Information:** Displaying the software and hardware information on NAUTIZ X3.

Adjusting Volume

How to adjust volume using speaker icon on the Navigation Bar.

1. Tap the speaker icon to open the volume dialogue box.



Figure 2-8. Volume dialogue box

2. Adjust volume moving the slide bar by dragging it.
3. Turn on or off the volume by selecting turn-off or turn-on radio button.

You can adjust system volume via Sounds and Alarms window or use the up-and-down button located on the side of NAUTIZ X3.

Display of battery level

Battery icon on the Navigation Bar indicates battery power level. If the main battery is lower than the pre-specified level, the corresponding icon displays the level; when battery dialogue box appears, it displays the main battery level.



Figure 2-9. Battery level dialogue box

On the Home Screen, the battery icon is always displayed on the Navigation Bar, indicating battery level. The message will be displayed until it is dismissed.



Figure 2-10. Battery icon on the title bar

Or you can check battery level by opening the power window.

Resetting NAUTIZ X3

There are two kinds of resets: Soft rest and hard reset. A soft reset will restart NAUTIZ X3 after closing all running programs. A hard reset, also, restarts NAUTIZ X3 along with resetting the clock. The data stored in flash memory or storage card will remain intact.

If NAUTIZ X3 is not working properly, perform a soft reset first. If the problem persists, perform a hard reset.

How to perform a soft reset

Press the reset button at the back of the device (over the battery cover) with a stylus.

(Reset button)

How to perform a hard reset

Quickly press the reset button at the back of the device (over the battery) with a stylus while pressing power button at the front.

(Power button + reset button)

Turning on or off backlight

Press power button at the front of the device for a short while.

(Power button)

Locking NAUTIZ X3

Prevent unauthorized use of the device by using the device-locking feature. When locked, NAUTIZ X3 will not respond to all input from the screen or keyboard.

To lock NAUTIZ X3, tap Lock icon that looks like a lock beneath the Start.

To unlock NAUTIZ X3, slide the lock button to the left or to the right.



Figure 2-18. Device-unlock window

If NAUTIZ X3 is locked with a password, a message asking a password will be prompted.

Locking with a password

This feature protects NAUTIZ X3 from unauthorized access by setting a password in the password window.

Note: if the device is configured to be connected to a network, a user must strengthen network security using complicated (hard to figure out) password. The tools for cracking password are advancing day by day, and the computers being used for cracking passwords are becoming more powerful than ever.

1. Go to Start > Setting > Lock > Password tab.

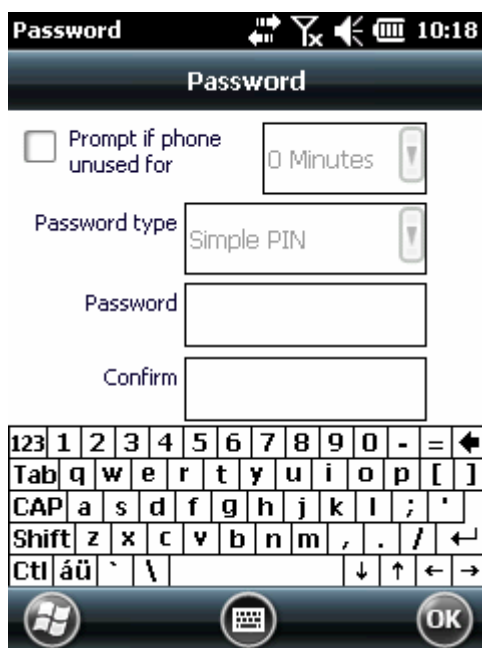

Figure 2-19. Password window and password tab

2. Activate password protection by checking confirm column, if the device is not going to be used for a specified period of time.
3. Select time value that forces protective function to be activated, if the device is not used for a specific period of time from the drop-down menu.
4. Password type: Select simple PIN or a complicated combination of English alphabets and numbers.
5. Simple passwords can be created by entering 4 digit numbers.

How to create a complicated password

- a. Password: Enter 7 digit numbers to create a complicated password. A complicated password must be composed of more than 7 characters, including at least 3 elements out of uppercase letters, lowercase letters, numbers, and a punctuation mark.
- b. Confirm: Reenter the password

6. Tap Confirm.
7. If you want to enter a hint to easily recall the password in the future, tap Hint column.
8. Enter a hint for recalling the password into the text box.
9. Tap Confirm.

When a user tries to access NAUTIZ X3 after a certain period of unused time, a password screen will be prompted. This window is also prompted when NAUTIZ X3 is connected with a host computer via the cradle or via the communication cable.



Enter the password to unlock the device.

Tap Unlock button to unlock the device and go to the Home Screen or you can go to Contacts window by tapping the Contacts button or go to Message window after unlocking the device by tapping the email button.

Function buttons

Emergency phone calls can be made even if NAUTIZ X3 is locked. Refer to the detailed information.

The buttons of NAUTIZ X3 have special functions.

2-21 Function buttons

- Power: You can turn on or off NAUTIZ X3 screen by pressing the red power button. When the screen is turned off, CW enters stand-by mode. For further information, refer to How to turn on NAUTIZ X3 in page 7. Or a user can reset NAUTIZ X3 by performing a soft

reset or a hard reset. Refer to CW reset in page 16.

- A user may scan barcodes or capture images. Refer to Data Capture in chapter 3. Or a user may open applications or perform specific functions. Refer to user's manual of applications for Microsoft Windows Mobile 6 to open the applications.
- Up/Down: Increase or decrease the volume of NAUTIZ X3.
- Task: A user is able to launch an application or perform a specific function. Refer to user's manual of applications for Microsoft Windows Mobile 6 to launch the application.

Stylus

A user can use a stylus for selecting items and entering information when using NAUTIZ X3. A stylus is for NAUTIZ X3 what a mouse is for a computer.

- Press: Tap the option button on the screen once with the stylus to open menu items.
- Press and hold: If you press and hold on an item, a list displaying available tasks appears. Tap a desired task on the displayed pop-up menu.
- Drag: A user can select text and images by dragging them with the stylus holding on the screen. In order to select several items drag them from a list.

Note! : When taking notes, you'd better to use the end of the stylus where a spring is installed, and when you tap the screen, it is recommended to use other end of the stylus. Press the power button and tap the keypad with your finger.

Warning! : Do not use other tools except for the stylus provided by Handheld in order to avoid damage on the screen.

Data entry

When you enter data using the keypad, you can use just one hand or use both hands

Viewing pictures and videos

How to view pictures and video clips

1. Tap Start > Pictures and Videos icon
2. Choose pictures or video clips you want to view.

Taking a picture

How to take a picture

1. Tap Start > Pictures and Videos icon.
2. Choose camera on the navigation bar.
3. Check the image in the view finder, and, if necessary, adjust settings.
4. Press Enter key to take a picture.

Video recording

How to create video clips

1. Tap Start > Pictures and Videos icon
2. Tap camera icon on the navigation bar
3. Choose Menu > Videos to set the shooting mode to video.
Available recording time will be displayed on the screen.

Note! : The default video recording time is limited to 30 seconds.

4. Start recording by tapping Enter key
Stop recording by tapping Enter key again

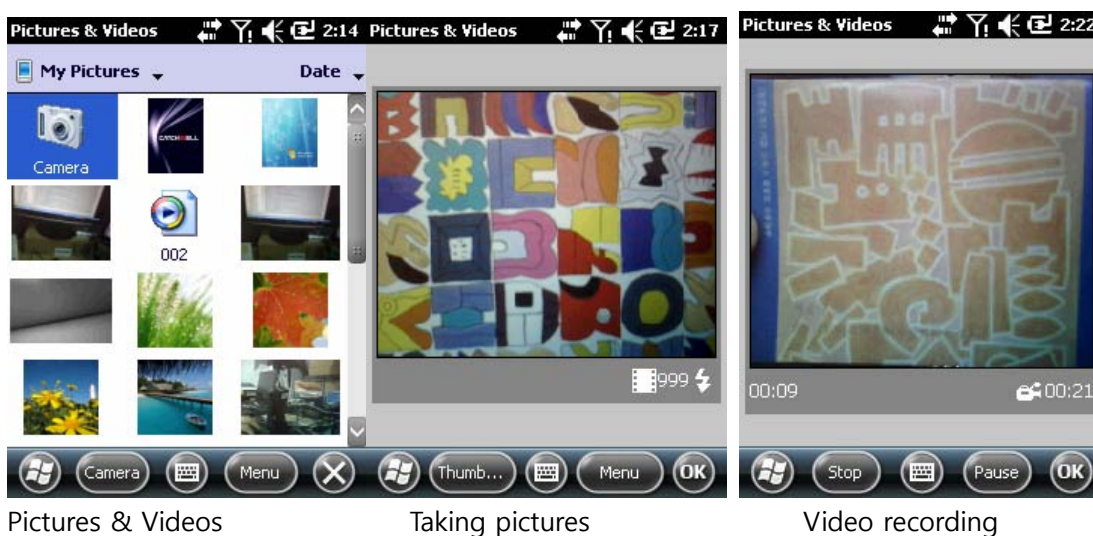

Chapter 3 Data Capture

Overview

NAUTIZ X3 provides two kinds of data capture modes:

- Laser decoding
- Image decoding

✓ Note:

To perform data capture mode, a scanning application must be installed in NAUTIZ X3.

Trial applications can be downloaded from CACHEWELL web page: <http://211.54.90.219>

Laser scanning

The barcode scanning features of NAUTIZ X3 are as follows:

- Recognizing various linear barcodes such as Code39, Codel128, or 1-dimension barcodes, etc.
- User-defined setting mode customizable for users' working environments.

Things to be considered for scanning

Generally, scanning is a very simple task composed of leveling, scanning, and decoding. Therefore, a user can be familiar with the process after a few trials. However, the followings should be noted beforehand to optimize the scanning performance:

- Distance
All scanning devices have their optimal recognition range (minimum or maximum distance from a barcode). This range may differ in barcode sizes or in the type of scanning devices.
If a scanning task is performed within the range, scanning will be fast and reliable, but if the task is performed within too close distance or too far distance, the success rate will decrease. When scanning, move NAUTIZ X3 forward and backward in order to find an optimal operation range.
- Angle
Scanning at too tilted angle is more likely to fail in recognition.
- The bigger a barcode is, the greater distance between the barcode and NAUTIZ X3 should be.
- The shorter the distance between barcodes, the closer the use of NAUTIZ X3.

Scanning barcodes

1. Check a scanning application is running in NAUTIZ X3.
2. Laser beam comes out of the end of NAUTIZ X3 while the scan button is pressed. The red scan beam should cover the entire barcode. The laser beam indicates that scanning is under way, and if an alarm goes off and the laser is turned off indicates that the barcode was successfully decoded.



<correct>



<incorrect>

3. Release the scan button.

Image decoding

The features of NAUTIZ X3 to which an image scanner is integrated are as follows:

- Recognizing linear barcodes such as Code39 and Code128, including 2-D barcodes such as PDF417 and QR code.
- Photographing images for various applications
- Intuitive aimer

The image scanner photographs barcodes using digital camera technologies and saves the photographed images, and then extracts data with an optimal decoding algorithm.

Operation modes

The NAUTIZ X3 to which an integrated image scanner is integrated supports 4 operations mode. Each mode can be changed on the barcode setting menu.

Decode Only: Decodes a barcode. The scanner remains decoding mode while pressing the scan button or until decoding is completed.

Image Decode: Simultaneously proceeding barcode decoding with barcode-image filming.

Image Only: Only photographing barcode images.

Multi-scan Mode: Decoding multiple barcodes quickly and conveniently. New barcodes can be decoded while keeping the scan button pressed.

Image scanning

1. Check an application necessary for scanning is running in NAUTIZ X3.
2. Pressing the scanning button turns on the aiming pattern helping to level at a target. Move the aiming pattern to the center of a barcode area. The red laser beams indicates that scanning is under way, and an alarm goes off, meaning that decoding of the barcode was successful.



3. Release the scan button.

Chapter 4 Using the phone

Overview

Using NAUTIZ X3, a user can make a call, save contacts, manage phone call records, send text messages, save received messages, etc.

In addition, a user can browse the web via a dial-up network to send data in real time using various office applications.

Using the phone application

Regardless of running programs, a user can use the phone application anytime he wants.



In order to use the phone application, choose Start > Phone or just tap the green button on the keypad of NAUTIZ X3.

Turning on or off the phone

The phone can be activated or deactivated via the Wireless Manager in a Windows Mobile 6.5 device.

Wireless can be launched by choosing Start > Settings > Connections.

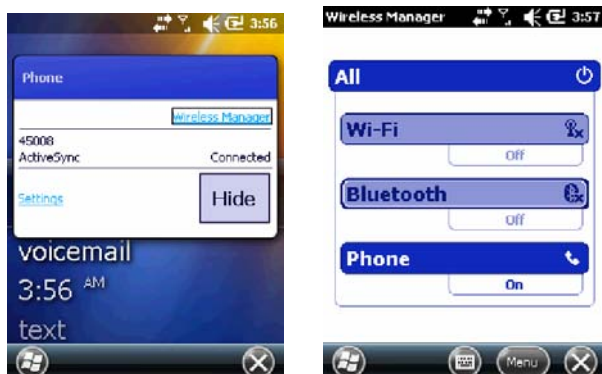

Choose the Wireless Manager.

Turn on or off a device by selecting its name.

To configure connection settings tap Menu > the settings of each device.

Audio mode

You can select one of three audio modes of NAUTIZ X3 when making a phone call.

Handset mode: You can use a speaker at the front side of NAUTIZ X3. This is the default mode.

Speaker mode: a user can use this mode like a speaker phone.

Headset mode: a user can connect a headset to NAUTIZ X3 or use a Bluetooth headset for making a call.

The default mode is handset mode. A user can listen to audio media via a headset or a Bluetooth headset by connecting them to NAUTIZ X3.

Using wired headsets

Headsets can be used for audio applications. NAUTIZ X3 Connect a headset to the earphone jack located on the side of NAUTIZ X3. Adjust volume appropriately before connecting the headset. When connected, sound doesn't come out of the speaker any more.

Using Bluetooth headsets

A Bluetooth headset can be used for audio applications for audio communication. Bluetooth Refer to chapter 6 – Using Bluetooth—to find out how to connect headsets to CW3. Adjust volume appropriately before turning on the headset. When connected, sound doesn't come out of the speaker any longer.

When making a phone call, the use of Bluetooth hand-free profile is recommended instead of using Headset profile. For more details, refer to chapter 6 – Using Bluetooth.

Adjusting audio volume

Adjust ring volume by pressing volume control settings or volume button located on the top, and adjust audio volume while making a phone call.

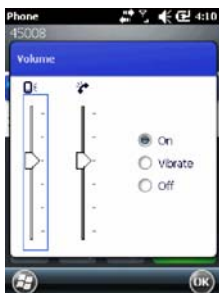

To adjust volume, tap speaker icon that comes up after tapping the title bar. Adjust volume by

moving the slide up and down.

Making a phone call

- ✓ Note: Making an emergency call is possible even if the SIM card is not installed. Refer to page 7 for more details.

A user can make a call via voice call, contacts, call list, and text message box on NAUTIZ X3.

Using the Phone Dialer

Making a phone call using the phone program

1. Choose Tap Start > Phone or Tap the green Talk key on the keypad of NAUTIZ X3.
 2. Tap a number that you wish to call from the Phone program.
 3. Press Send or the green Talk key on the keypad of NAUTIZ X3.
 4. To stop an outbound call or terminate a call, press End or tap the red End key on NAUTIZ X3 keypad.
- ✓ When wrong keys are pressed, erase the numbers by tapping Delete key one by one.

Using Contacts

A user can make a call using Contacts

How to make a call from the Contacts screen.

1. Tap Start > Contacts
2. Select a contact and press and hold on it for a short while in the contacts list.

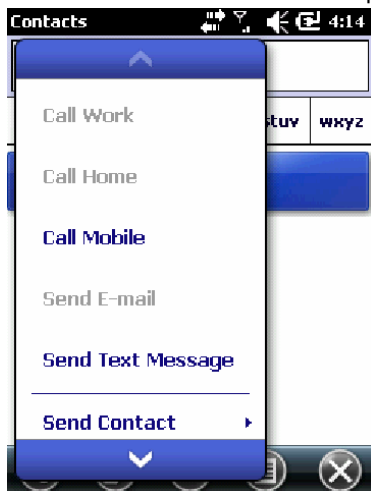

3. Choose Call Work or Call Home or Call Mobile.

Using Call History

How to make a call using Call History

1. Tap Start > Phone or Tap the green Talk key on NAUTIZ X3 keypad.
2. Tap a Call History on the Phone keypad.

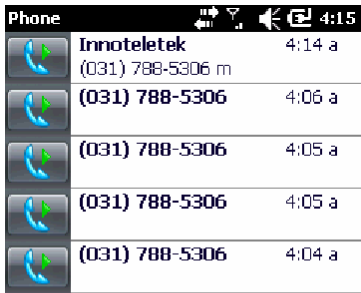

3. Start voice call by tapping the phone icon next to the number.
4. To make a call or terminate a call, tap End or tap the red End Call key on NAUTIZ X3 keypad.

Making emergency calls

You can use an emergency call even if the SIM card is not installed. For more details on the installation of the SIM card, refer to SIM Card Installation on page 3.

- ✓ Note: Emergency calls can be unavailable depending on network environments.

Answering Calls

When you have an incoming call, a pop-up window will appear. If a bell sound is set, the phone will ring.

To answer the call, tap Phone > Receive or tap the green Talk key on NAUTIZ X3 keypad.

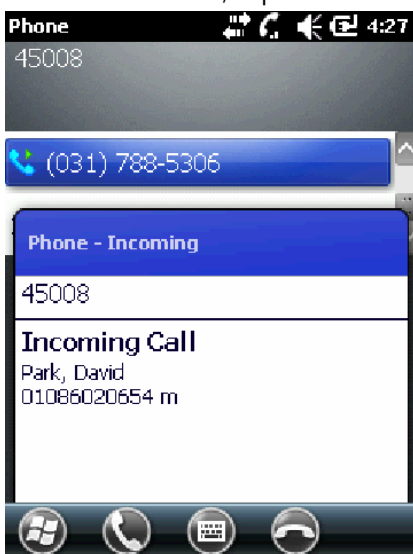

To ignore the incoming call, press Ignore. Then the service provider you are using will notify the caller that you are unable to answer the call.

To end the call, tap End Call or tap the red END on NAUTIZ X3 keypad.

Handling incoming calls

- To answer an incoming call when you are already on a call, tap Stand-by key to switch to stand-by mode.
- You can use other programs of NAUTIZ X3 while you are on a call. If you want to switch to Phone screen, tap Talk or Start > Phone. To end the call, tap End Call.
- You can add the number you are on a call or a number on the Call History to Contacts by tapping Menu > Contact > Save.
- To answer another incoming call while you are talking on the phone, tap Answer or Send after disconnecting the current call by tapping End on Phone keypad and tap Answer or Send key.
- To answer a stand-by call during a call, answer the call after tapping Answer or Send to switch the current call to stand-by mode.

Smart Dialing

When you start to enter numbers or letters, the device automatically shows you filtered list of contacts and phone numbers after searching for the contact items and the numbers from call history. Then you can choose a contact from the filtered list.

Tap a phone number to make a call. At this point, a contact matching the entered number will be displayed on the contacts panel.

To search for phone numbers

- You can search for phone numbers by entering on or two numbers at the beginning.
- By entering more than three numbers at the beginning, you can search for saved contacts and phone numbers from SIM card.

How to find contacts

- Enter the first letter of the name in contacts.
- If there are many matching items, you can narrow your search by adding extra letters.



How to make a call or send a text message using Smart Dialing.

1. Enter numbers or letters at the beginning.
2. Search for contacts or numbers that you wish to find from the Smart Dialing panel.
3. When you choose a contact, tap Talk to make a call.
4. If you want to send a text message after selecting a contact, tap Menu > Text Message.
5. You can select other phone numbers of that contact by tapping the name in the contact after selecting it.

To mute the microphone during a call

If you mute the microphone during a call, you can hear the voice of the other, but the other can't hear your voice.

How to mute or unmute the microphone during a call

1. Tap Start > Phone or tap the green Talk key on NAUTIZ X3 keypad.
2. Make a call.
3. Tap Mute on the screen to mute the audio. The mute icon will appear on the screen.



Creating a memo

To create a memo during a call, tap Menu button on the screen, then select Create Memo.

How to check the memo created during a call

1. Tap Start > Phone or tap the green Talk key on NAUTIZ X3 keypad.
2. Tap Call History on the Phone keypad.
3. Press and hold on a call record including a memo or the memo icon.

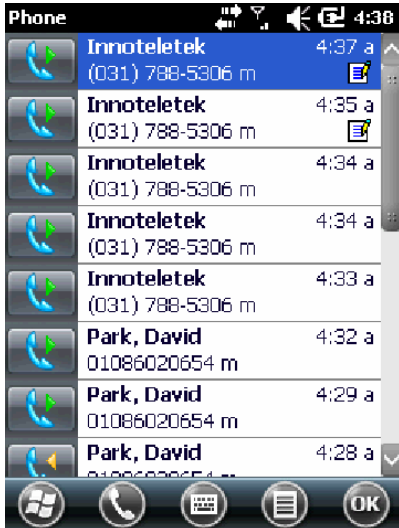

4. Tap View Memo.
 5. Tap OK to end.
- ✓ Note: You can check the Memo program directly by choosing Start > Memo.
- ✓

Using Speed Dial

You can make a call with a single tap by creating a speed dial entry. After assigning a number to Contacts, you can add the number to the Speed Dial.

How to add an item to Speed Dial

How to add a number to Speed Dial on the Phone keypad

1. Check if there are contacts and numbers that you wish to add to the Speed Dial in the Call History.
2. Tap Start > Phone or tap the green Talk key on NAUTIZ X3.
3. Tap Speed Dial > Menu > New.

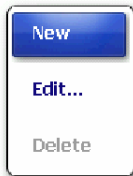

4. Select an item you wish to add to Speed Dial from the Contacts list.



Contact: Innoteletek

Name:

Number:

Location:



5. Select a new Speed Dial number from the Location column. The first number of the Speed Dial is reserved for voice mail.
6. Tap OK to add the contact to Speed Dial list.

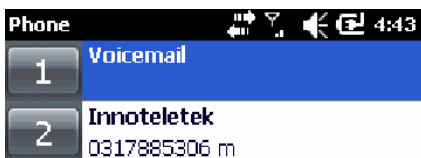

Editing or Deleting Speed Dial shortcut

1. Tap Start > Phone or tap the green Talk key on NAUTIZ X3.
2. Tap Speed Dial button.

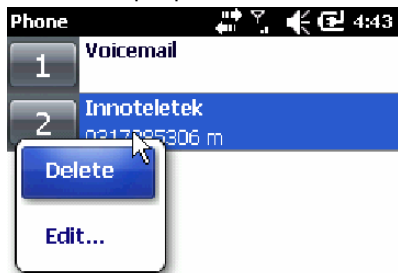



3. Press Edit... or an item to be deleted for a short while.
4. Tap Edit... or Delete.

Using Call History

You can check recent calls or make a call to the numbers using Call History. In Call History, the duration of all received, sent, missed calls and talk time are displayed. The icons displayed in the Call History screen are listed in Table 4-1.

표 4-1 통화 기록 아이콘

아이콘	설명
	이 아이콘은 모든 발신 통화에 대한 연락처 정보 옆에 표시됩니다.
	이 아이콘은 모든 수신 통화에 대한 연락처 정보 옆에 표시됩니다.
	이 아이콘은 모든 부재 중 통화에 대한 연락처 정보 옆에 표시됩니다.



This icon is displayed next to the contact information on all incoming calls.



This icon is displayed next to the contact information on all missed calls.



This icon is displayed next to the contact information on all outgoing calls.

Managing Call History

You can manage your call history such as resetting talk time and deleting call history.

Modifying Call History View

1. Tap Start > Phone or tap the green Talk key on NAUTIZ X3 to display the phone keypad.
2. Tap Call History button on the phone keypad.
3. Tap Menu > Filter to display the menu.

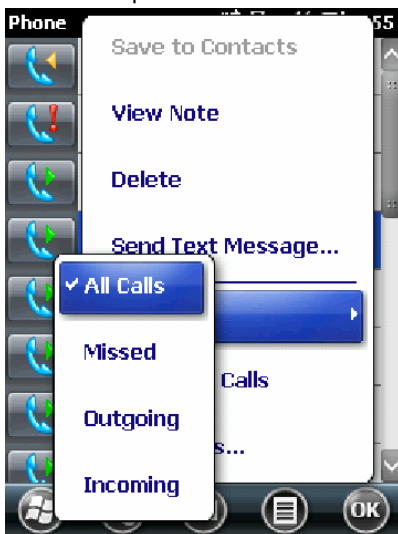

4. You can only display missed, outgoing, and incoming calls on the menu.

Resetting the recent call counter

1. Tap Start > Phone or tap the green Talk key on NAUTIZ X3 keypad.
2. Tap Call History on the phone keypad.
3. Tap Menu.

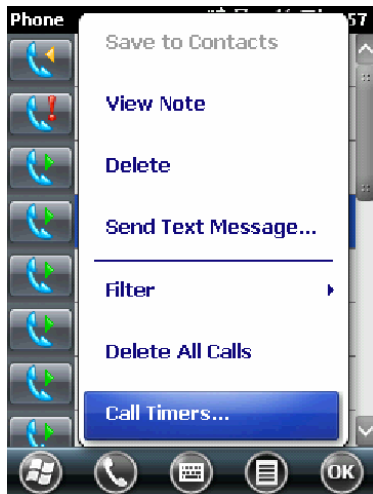

4. Choose Call Timers.



5. Tap Reset (Not counters of all calls are initialized).

Deleting all Call History

1. Tap Start > Phone or tap the green Talk key on NAUTIZ X3 keypad.
2. Tap Call History on the phone keypad.
3. Tap Menu icon.

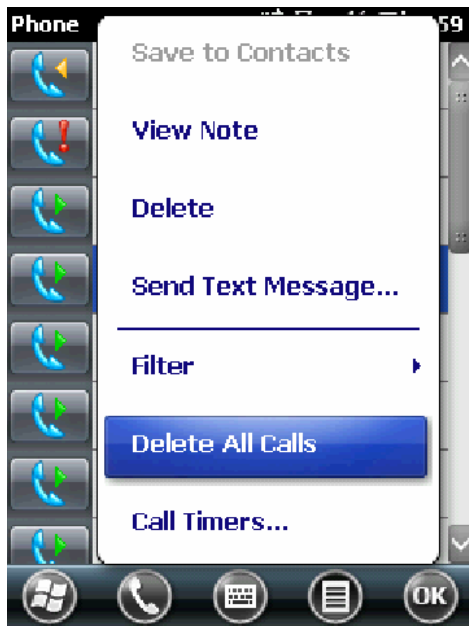

4. Choose Delete All Calls.

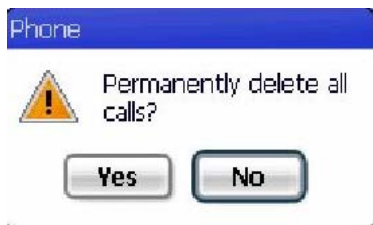

5. Tap Yes.

Viewing call details

1. Tap Start > Phone or tap the green Talk key on NAUTIZ X3 keypad.
2. Tap Call History on the phone keypad.
3. Choosing an item will lead you to the call details screen.

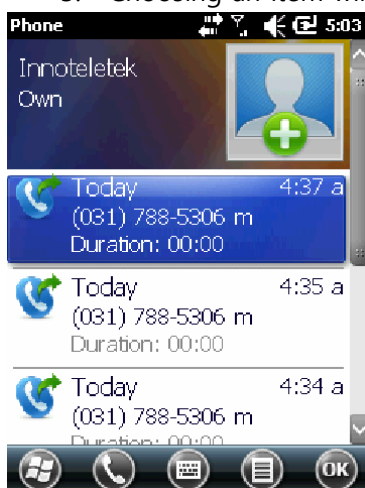

✓ Note: If more than two calls are in progress, only the first one will be recorded.

Using Call History menu

You can send voicemails, save contacts, delete history, and voice calls using Call History menu.

1. Tap Start > Phone or tap the green Talk key on NAUTIZ X3.
2. Tap Call History on the phone keypad.
3. Press and hold on the desired item in the list for a while.

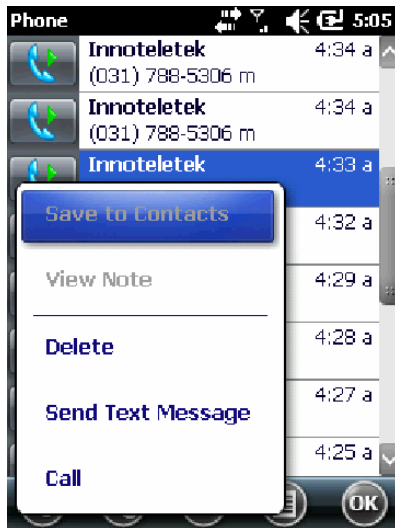

4. Choose an item on the menu.

Switching calls on NAUTIZ X3.

How to switch calls between two calls:

1. Tap Start > Phone or tap the green Talk key on NAUTIZ X3 keypad.
2. When the first call is connected, Stand-by button will be displayed on the keypad.
3. Tap the Stand-by button to switch the first call to stand-by mode.
4. Proceed with the second call.
5. After being connected to the second call, a switching button will be displayed on the keypad.
6. To end each call, tap End on the phone keypad or tap the red End Talk key on NAUTIZ X3 keypad.

Conference call using NAUTIZ X3

- ✓ Note: Not all mobile phone networks support conference calling. Contact your wireless service provider to find out whether they support conference calling.

Text message

You can send or receive text messages using Text Message features.

Viewing text messages

How to view text messages

Regardless of using voice call, you can check your text messages. You will be notified by New Text Message Notification window when you have a new text message.



Notification of new text message

On the new text message screen, you can make a call, save or read or delete messages. If you are subscribed to Caller's Number Identification Service, you can identify the caller by comparing the number with the information saved on Contacts.

Even if the phone is disabled, you can still read received text messages.

1. Tab Start > Text Message.



2. Text Message window will appear.
3. Tap a text message in the message list.

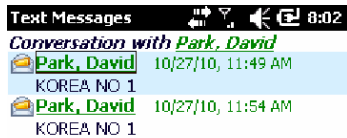

- ✓ Note: When the phone is turned off, you have to turn it on to make a call or to send a new message.

Sending text messages

How to create a new text message

1. Tap Start > Text Message
2. Tap Create New Text Message.

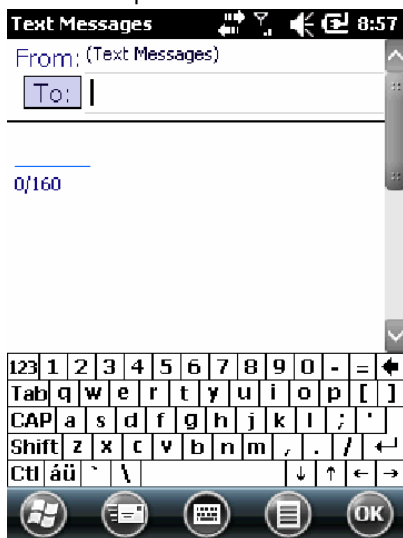

- You can check the size of the message you are writing via character counter.
 - If you want to know whether the receiver has received your message, choose Message Transmission Check Request after tapping Menu > Message Option.
3. You can enter the receiver's number into the receiver's number column or enter the number by searching for the number from Contacts after tapping Menu > Add Receivers...
 4. Enter a message into the message area.
 5. When completed, tap Send button.

When the phone is turned on, a message notifying you to turn on the phone will be prompted. You can turn on the phone to send a message or save a message at the temporary folder by

tapping OK. The message saved at the temporary folder will be sent when you turn on the phone.

If you are out of the communication service area, a message will be saved at Temporary message box and be sent when you are back to the service area.

- ✓ Note: As the message saved at temporary message box remains there, you have to send the message manually when you are back to the service area (necessary to check the relevant features).

Chapter 5 Using a GPS Navigation

Overview

NAUTIZ X3 adopted a GPS (Global Positioning System) technology using SiRF III chipset. GPS technology is based on GPS satellites that transmit digital wireless signals constantly orbiting the Earth. Those wireless signals contain precise time data, and this signal is used for identifying the location of a user.

Warning!

The user is responsible for the safe use of SW30 in a car by correctly fixing it on a safe place free from blocking vision or causing accidents, injuries, or damages. A driver must drive safely, attending to all traffics, and take special care not to risk safe driving by using this device. To use this device while driving is dangerous.

Installing a software

- A GPS navigation software released by a third party is necessary, and several evaluation copies of such software are available from various manufacturers. For instance, to use VisualGPS, please visit <http://www.visualgps.net/VisualGPSce/>.

If you want to purchase a GPS navigation software, please ask the GPS manufacturer that the software you are going to buy is compatible with NAUTIZ X3 before purchasing or downloading or installation. For the installation and configuration of applications, please refer to the user's manual for the relevant application.

Setting up GPS on NAUTIZ X3

- The basic features of NAUTIZ X3 are as follows:

1. Choose Start > Settings > System > External GPS.
2. Set GPS program port to COM4 from the program tab.
3. Set GPS program port to COM9 from the hardware tab.
4. Set baud rate to 9600 from the hardware tab.

Several programs can access GPS data simultaneously. Each program must access GPS data using Microsoft GPS API or COM8.

Operation

- Though there is a default setting, it is subject to change.
- It may take from a few seconds to several minutes before receiving satellite signals. The outdoor location where there are no obstacles blocking the sky is ideal. If such a location is not available, it may take longer time to receive the signals or NAUTIZ X3 may be unable to calculate the initial position quickly. In case of indoor use, the access to GPS signals may be restricted or impossible.

Note:

- When you using a GPS navigation program, make sure NAUTIZ X3 is not switched to temporary pause mode. If NAUTIZ X3 is in temporary pause mode, power to the GPS module will be cut off. To continue to use GPS, the GPS receiver has to search for effective GPS signals again; as a result, the retrieval of location information will be delayed.

GPS maps on a microSD card

- There are GPS navigation software vendors who are selling GPS maps on microSD cards. In case of using microSD for navigation software:

1. Remove the battery from NAUTIZ X3.
2. Push up the SD card slot located inside the battery compartment at the back of PDA to the right.
3. Insert the SD card into the slot.
4. Push the slot where SD card is inserted to the left by pulling it down.

Answering calls while using GPS

- When there is an incoming call while using a GPS navigation program:

1. Tap Answer button to receive the call.
2. After finishing the call, tap Talk End button to restart the audio of GPS software.

Note:

- When receiving incoming calls while using GPS on NAUTIZ X3, the audio of the GPS navigation software will be muted until the call is finished

When you lose GPS signals in a car

- If the window of your car is heating-wired, it may affect the GPS performance of NAUTIZ X3 by blocking the GPS signals. To strengthen GPS signals, install NAUTIZ X3 to the place exposed to the sky without any obstacles. To access satellite information, NAUTIZ X3 and GPS satellites should be remain in line of sight.

A user can track his own location using GPS (Global Positioning System).

Auxiliary GPS

If there is no internal GPS in the device, a user may use a Bluetooth GPS. For the details on how to set up a Bluetooth device, refer to chapter 6 – Bluetooth.

For how to use them, see the user's manuals released by each vendor.

Chapter 6 Using Bluetooth

Overview

A device equipped with Bluetooth technology can send and receive data within the frequency range (802.15.1) of 2.4GHz ISM (Industry Scientific and Medical) by communicating wirelessly with radio frequency in FHSS (frequency-hopping spread spectrum). Bluetooth wireless technology is, in particular, designed for short-range communication (10 m / 30 ft) and low-power consumption.

NAUTIZ X3, equipped with Bluetooth technology, is able to exchange information (e.g. files, appointments, tasks) with other Bluetooth-support devices such as phones, printers, access points, or other mobile computers. To use NAUTIZ X3 as a modem, you can establish a dial-up modem connection between a computer and NAUTIZ X3.

AFH (Adaptive Frequency Hopping)

- AFH (Adaptive Frequency Hopping), a way of avoiding fixed frequency interference, can be applied to Bluetooth voice. In order for AFH to operate correctly, all devices of piconet (Bluetooth network) must support AFH. When searching and connecting to devices, AFH is not used. Refrain from using Bluetooth pairing or search when an important 802.11b communication is underway. The AFH for Bluetooth consists of four major components:

. It is a way of detecting interference according to the pre-defined channel masks or standards of each channel.

. Link management– It distributes adjusted AFH information over the rest of Bluetooth network

. Modification of hopping order– It prevents interference by selectively reducing the number of hopping channels.

. Channel maintenance –It is a way of re-evaluating channels periodically.

When AFH is activated, Bluetooth communication hops to near high-speed 802.11b channels instead of passing through them.

Bluetooth wireless connection of NAUTIZ X3 is working at Class 2 device power level. The maximum output power is 2.5 mW and the estimated distance is 10 m (32.8 ft). The distance depending on power levels may differ in the measured environments such as open space or closed office space, etc. Therefore, it is difficult to define the right distance due to the differences in power and devices.

Note: It is recommended that a user may not conduct Bluetooth wireless technology search when high-speed 802.11b connections is required.

Security

- In the current Bluetooth specifications, the security level is defined to the level of link and the security level of applications is not defined. Therefore, application developers may define security mechanisms to meet specific requirements. The security at the level of applications is

implemented per each user, whereas the security at the level of link is implemented between devices. The Bluetooth specifications define security algorithms and procedures necessary to certificate devices and, if necessary, to encrypt the data flow of link between devices. The certification of devices is a fundamental feature of Bluetooth; however, the encryption of link is selective.

The synchronization between Bluetooth devices are performed by generating initialization keys used for link keys required for certifying devices. Basically, a Bluetooth stack responds without a key when a key is requested (the response to the key-requesting event is the user's role). The certification of Bluetooth devices are based on attempt-response transactions. In Bluetooth technology, other PIN numbers or passwords used for generating 128 bit keys for security and encryption can be re-used. Encrypted keys are extracted from the link keys used for certifying synchronized devices. Also, the constraints in distance and high-speed frequency hopping of Bluetooth wireless technology make eavesdropping difficult.

Recommendations are as follows:

- . Synchronization should be conducted under secured environments.
- . Do not save PIN code at industrial PDA. Store it somewhere else personally.
- . Implement a security at the level of applications.

Microsoft stack supports smart synchronization. For the details, see Microsoft MSDN.

Composition of Bluetooth

- In principle, NAUTIZ X3 is configured to use Microsoft Bluetooth stack.

The available services via Microsoft Bluetooth stack is listed in Table 6-1.

<Table 6-1. Bluetooth services>

Microsoft Bluetooth Stack
OBEX Object Push Services
Hands-Free Audio Gateway Services
Serial Port Services
Personal Area Networking Services
PBAP Services
Dial-Up Networking Services
HID Client Services
A2DP/AVRCP Services

The ports supported by Microsoft Bluetooth Stack

COM5

COM9

For more details on ports, contact Technical Support Team at Handheld.

Power states of Bluetooth

Hard reset

Using Microsoft Bluetooth Stack

- If you perform a hard reset, the Bluetooth wireless condition before hard reset remains.

Soft reset

Using Microsoft Bluetooth Stack

- If you perform a soft reset, the Bluetooth wireless condition before hard reset remains.

Pause

- If there is an active Bluetooth pairing, the Bluetooth wireless connection enters low-power consumption mode to maintain the active pairing. If there is no active pairing, the Bluetooth wireless connection will be disconnected.

Using Microsoft Bluetooth Stack

Note: Under the condition that the Bluetooth pairing between NAUTIZ X3 and other Bluetooth device is active, if there is no data exchange between the devices, NAUTIZ X3 will be timed out. However, once the power button of NAUTIZ X3 is pressed, NAUTIZ X3 will be temporarily suspended (except for the case of making a call), and NAUTIZ X3 will be awake from the suspend mode right after receiving data from the Bluetooth device. For example, if redialing is made from a headset, the suspension will be disengaged.

Restart

- If Bluetooth was on before temporary suspension, it will be powered on when NAUTIZ X3 restarts.

Using Microsoft Bluetooth Stack

In the next chapter, how to use Microsoft Bluetooth Stack will be explained.

Turning on or off the Bluetooth Wireless mode

- Turn off Bluetooth wireless connection to save battery or when you enter an area where wireless connection is restricted (e.g. aircraft). When wireless connection is turned off, no other Bluetooth devices can detect or connect to NAUTIZ X3. To exchange information with other Bluetooth devices within the operation range, turn on the Bluetooth wireless connection. The communication using Bluetooth wireless connection is only available within the close distance.

Note: Turn off wireless connection when not in use to extend battery life.

Bluetooth activation

How to activate Bluetooth

1. Tap Bluetooth bar after tapping Wireless Manager or tap Start > Settings > Connection > Bluetooth icon.

<Figure 6-1. Bluetooth mode tab >

2. Select Turn on Bluetooth.

3. Tap Yes.

Bluetooth deactivation

How to deactivate Bluetooth

1. Tap Bluetooth bar after tapping Wireless Manager or tap Start > Settings > Connection > Bluetooth icon.

2. Deselect Turn on Bluetooth

3. Tap Yes.

Searching for Bluetooth devices

- NAUTIZ X3 can receive information from a detected device without connecting to it. But, when connected, the device connected to NAUTIZ X3 will automatically exchange data with NAUTIZ X3 if Bluetooth wireless connection is activated.

How to find a Bluetooth device within the range

1. Activate Bluetooth on both devices.

2. Set the Bluetooth devices to detection and connection-enabled mode.

3. Check the distance between the devices is within 10 m (30 ft).

4. Choose Start > Settings > Connection > Bluetooth > Device.

<Figure 6-2 Bluetooth device tab>

5. Tap Add New Device. Then NAUTIZ X3 will begin to search for a new Bluetooth device within the range.

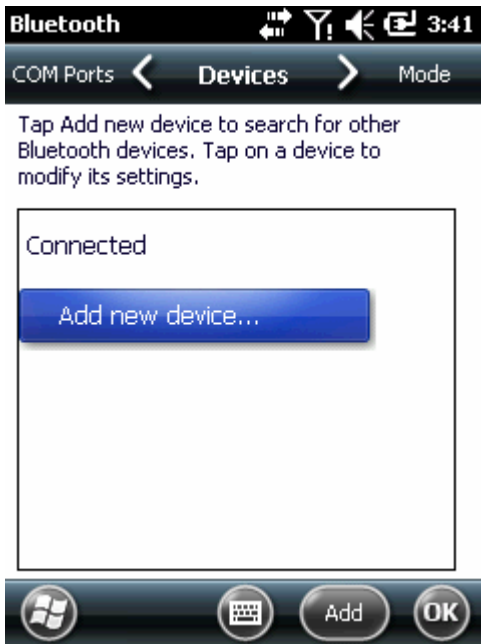

<Figure 6-3. Searching for a Bluetooth device >

6. Choose a device from the list.

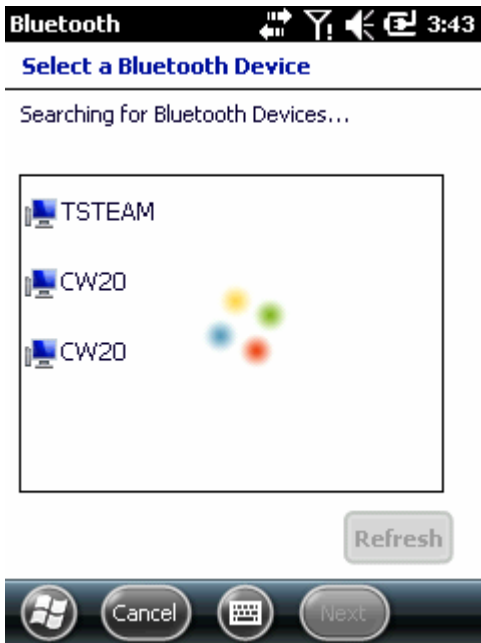

<Figure Selecting a Bluetooth device>

7. Tap Next. A password input screen will appear.

Note: If smart synchronization is pre-configured or pre-defined PIN is requested, the password input screen will not appear.

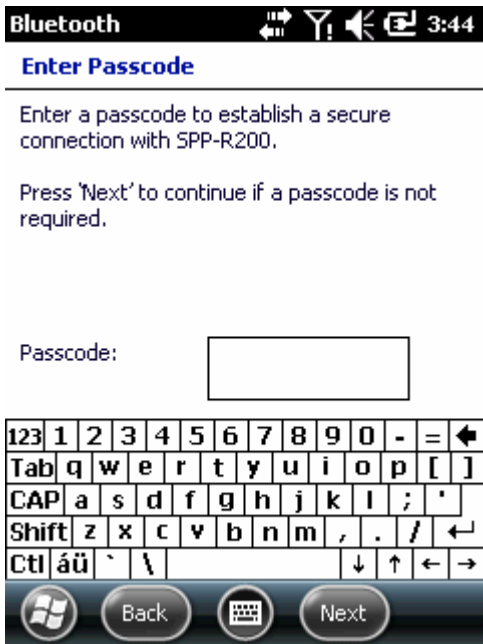

<Figure 6-5. Entering a password>

8. Enter a password of other device. Then the device will be added to Bluetooth device list.



<Figure 6-6. Bluetooth pairing set-up>

A message requesting a password will appear. If there is a specific password for the device, enter the password to the Password column and tap Next. If there is no password for the device, enter an arbitrary password and tap Next. Bluetooth will attempts to establish a partnership with the device.

9. If there is a pre-defined password, the same message will appear in the other device requesting the password. Enter the password to configure the synchronized connection (if the password of the device is entered, there is no other tasks to perform on other device).

10. When connected, a list of appropriate and supporting services will appear.
11. Choose the service you want and tap OK. If you don't select the service, it will not be synchronized even if the device is synchronized. If you don't choose a service, a message that keeps asking you to enter a password will appear.
12. The device will appear in the list of the main panel. When the both devices accept their passwords, a reliable (synchronized) partnership is established.

Available Services

Note: Some devices may not require PIN depending on the certification of devices.

For the information on available services, refer to the next paragraph.

Hands-free Services

How to connect a Bluetooth headset

Note: The partnership with a Bluetooth headset is different from each headset, and the device only remembers the last connected headset. If a problem occurs while making a connection to a headset, switch the headset to detection mode. For more details, refer to user's manual of the headset. Only WAN audio will be transmitted to a headset. System audio will keep being transmitted to NAUTIZ X3 speaker. You can answer or make a call using a hands-free profile.

1. Activate Bluetooth in both devices and turn on detection mode.
2. Check the distance between the devices is within 10 m (30 ft).
3. Tap Start > Settings > Connections > Bluetooth icon.
4. Tap New Device. NAUTIZ X3 will begin to search for a Bluetooth device within the range.
5. Enter the name of the headset, and tap Next. A password window will appear.
6. Enter a password for the headset.
7. Tap Next. NAUTIZ X3 will be connected to the headset. For the instructions on the communications with Bluetooth devices, refer to the user's manual of the headset.

Note: While an active pairing is established, NAUTIZ X3 will not be switched into pause mode even after pressing the power button. Instead, a notification message will appear. The power button will be back in action after WAN communication is disconnected (in case of using hands-free profile).

Serial Port Services

Wireless Bluetooth uses serial port connection as well as the wired serial cable connection. It configures applications that will be used for connections to correct serial ports.

How to connect to serial ports

1. Activate Bluetooth on both devices and turn on detection mode.
2. Check the distance between two devices is within 10 m (30 ft).
3. Go to Start > Settings > Connections > Bluetooth > Device tab.

4. Tap Add New Devices. NAUTIZ X3 will start to search for a detectable Bluetooth device within the range.
 5. Select a device from the list.
 6. Tap Next. A screen asking a password will appear.
- Note: If smart synchronization is pre-configured and a pre-defined PIN is being requested, no screen asking a password will appear.
7. Enter a password and tap Next. The device will be added to the Bluetooth list.
 8. Tap a serial device from the device list. Connection settings screen will appear.
 9. Select the serial port confirmation column.
 10. Tap Save.
 11. Tap COM ports tab.

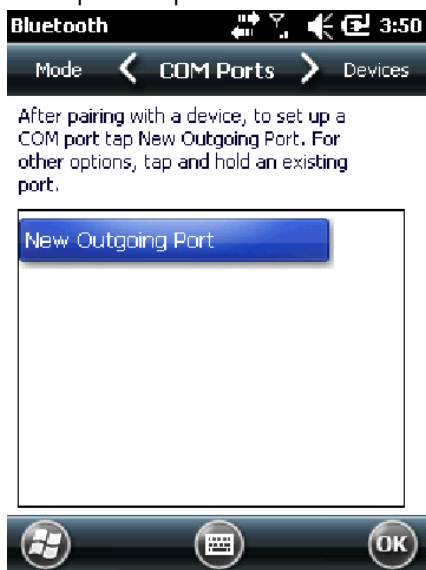

12. Tap New Outgoing Port. Add a Device screen will appear.
13. Select the serial device and tap Next.



14. Select a COM port from the drop-down menu.

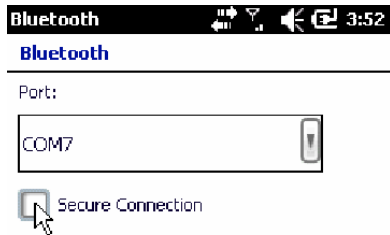

15. Tap Finish.

Note: This process alone will not create a partnership. To make a partnership again, the application must run Microsoft Bluetooth Stack by opening the selected COM port.

ActiveSync using serial port services

- As is the case with a wired serial cable connection, ActiveSync also uses a wireless Bluetooth serial port connection. Therefore, an application required for connecting to the correct serial port must be configured.

How to configure Bluetooth ActiveSync

Configure Bluetooth features of the device prior to establish a Bluetooth ActiveSync connection.

Note: In order to strengthen security, the network bridge (especially Remote NDIS adapter Connection Bridge) of a computer must be deactivated before connecting the device to a computer passing through the Internet or other networks. For further information on the network bridge, see Windows online help of the computer.

The following instructions correspond to the computers running Windows XP higher than SP2.

1. Activate Bluetooth on both devices and turn on detection mode. Check the distance between two devices is within 10 m (30 ft).
2. Double click Start > Settings > Configuration Panel > Bluetooth device.
3. Check Search for a Bluetooth Device checkbox on Option tab and Allow a New Bluetooth Device to Connect to This Computer checkbox.
4. Choose Receive (start connection from the device) options after clicking Add on COM port tab and click OK.
Click OK after checking the added COM port.
5. Click Start > ActiveSync.
6. Click File > Connection Settings
7. Allow one connection out of the followings: Press Start > ActiveSync after selecting a COM port whose number was checked in the previous step from the drop-down menu.
8. Choose a connection via Menu > Bluetooth.

Synchronization will automatically initiate and ActiveSync icon will appear at the bottom of the right corner on the Home Screen.

If certification is required, a password window will appear, then enter a password (PIN code) and press Enter and repeat this procedure on the other device. The use of password is recommended for enhanced security and the digit of a password should be between 1 to 16 characters combined with English letters and numbers. If you are not going to use a password, just click Next.

9. To disengage the ActiveSync connection, select ActiveSync icon on the Home Screen and click Disconnect.

A2DP/ AVRCP Services

A2DP/ AVRCP are used for connecting to high-quality stereo headsets.

1. Activate Bluetooth on the both device and set the Bluetooth device into detection and connection mode.

2. Check the distance between two devices is within 10 m (30 ft).

3. Tap Add a Device after selecting Start > Settings > Connections > Bluetooth. NAUTIZ X3 will start to search for a new Bluetooth device within the range.

4. Select the stereo headset from the list and tap Next. A screen asking a password will appear. For further information, refer to user's manual of the device.

Note: If smart synchronization is pre-configured and a pre-defined PIN is requested, the password screen will not appear.

5. Tapping Connection will pair NAUTIZ X3 with the stereo headset.

The stereo headset applicable to hands-free service will be connected to the hands-free service after being connected to A3DP service.

1. Tap Add a Device after choosing Start > Settings > Connections > Bluetooth. NAUTIZ X3 will begin to search for a new Bluetooth device within range.

2. Select the stereo headset in the list. Tapping Next will take you to a password window. For more details, refer to the user's manual of the device.

Note: If smart synchronization is pre-configured and a pre-defined PIN is requested, that password screen will not appear.

3. Tap Connection. NAUTIZ X3 will be paired with the stereo headset.

Chapter 7 Maintenance and Troubleshooting

This chapter will provide troubleshooting guidelines including instructions on the cleaning and storage of NAUTIZ X3.

Maintenance

Please follow the below instructions for trouble-free use of the device.

- Take special care to protect the screen of NAUTIZ X3 from being scratched. Only use a plastic pen designed for touch screen or the provided stylus. Never use other pens or pencils or other sharp object for the screen.
- The use of protective film is recommended (a sheet of film is included in the box).
- The advantages of using the protective film
 - Protecting the screen from scratches or grooves.
 - More realistic feeling in writing and touching
 - Protecting the screen from damage caused by abrasion and foreign materials.
 - Extending the lifespan of the touch screen.
- The screen of NAUTIZ X3 is made of glass. Do not drop NAUTIZ X3 or apply excessive shock to it.
- Protect NAUTIZ X3 from drastic temperature change. When temperature is high, do not keep it on the dashboard of a car and keep it away from heat sources.
- Do not use or store NAUTIZ X3 at dirty, humid, or wet places.
- Use a soft lens-cleaning cloth for cleaning NAUTIZ X3. If the surface of NAUTIZ X3 screen gets dirty, clean it with a diluted detergent.
- To maximize battery life and performance, replace the rechargeable battery periodically. The lifespan of battery may differ in every user depending on how he or she uses it.

Safety instructions on battery

- No debris, combustibles, chemicals are allowed near the battery on charging. Special caution is required in case of charging the battery under non-commercial environments.
- Use the battery in accordance with the instructions on how to use, store, and recharge in this manual.
- The use of improper battery may lead to fire and explosion. The charging temperature of the battery for mobile devices ranges from 0°C to 40°C (32°F ~ 104°F).
- Do not use incompatible batteries or chargers. The use of incompatible batteries or chargers may result the risks such as fire, explosion, leakage, etc. If you have any question on battery or charger, contact Handheld.
- Do not attempt to disassemble, open, bend, modify, puncture, or smash the product or the battery.
- If you drop the device in which the battery installed on the solid surface hard, the

battery may be overheated.

- Special attention must be paid to avoid short circuit, contacting a metal conductor to the battery terminals.
- Special attention must be paid to avoid modification, restoration, inserting foreign materials into the battery, exposing the battery to water or other liquids, fire, explosion, and other risks.
- Children's handling of the battery should be supervised by parents. .
- The used battery must be disposed of immediately as stipulated by the local regulations.
- Do not dispose of the battery in fire.
- In case of swallowing of the battery, consult the doctor immediately.
- If the battery leaks, be careful not to allow skin or eyes to be in contact with the leaking fluid, and if skin or eyes are already in contact, rinse with a large amount of water and seek medical advice.
- If a trouble suspicious of the damage of the device or the battery occurs, contact Handheld for check.

Cleaning

Cleaning the exterior of the device

Use only computer-cleaning detergents or dedicated cleaners.

Screen

Use only computer-cleaning detergents or dedicated cleaners. Be careful not to allow liquid to pervade into the gaps at the corner of screen. To avoid any scratch, wipe it off with a non-abrasive dry cloth.

Scanner window

Clean it regularly with a lens cleaner.

Connectors

1. Remove the battery.
2. Soak the end of a swap in isopropyl alcohol and rub connector pins with it.
3. Be careful not to leave any fluff at the surface of connectors.
4. Repeat this process about three times.

If isopropyl alcohol is not available, clean the connector pins with computer-cleaning detergent or a pencil eraser, and be careful not to leave any foreign materials at the surface of the pins.

Cradle

1. Remove the power cable from the cradle.
2. Soak the end of a swap in isopropyl alcohol and rub connector pins.
3. Be careful not to leave fluff at the surface of connectors.
4. Rub the connectors carefully, so that both sides of the connectors are surely cleaned; repeat this three times.
5. Remove the foreign materials inside the cradle with compressed air, etc.
6. Clean the exterior of the cradle with computer-cleaning detergents, etc.

As the level of contamination may vary depending on users' operation environments, clean the device regularly.

Safety Information

1 . SAFETY INFORMATION FOR FIXED WIRELESS TERMINALS

.POTENTIALLY EXPLOSIVE ATMOSPHERES

Turn your phone OFF when in any area with a potentially explosive atmosphere and obey all signs and instructions. Sparks in such areas could cause an explosion or fire resulting in bodily injury or even death.

INTERFERENCE TO MEDICAL DEVICES

Certain electronic equipment may be shielded against RF signal from your wireless phone. (pacemakers, Hearing Aids, and so on) Turn your phone OFF in health care facilities when any regulations posted in these areas instruct you to do so. RF signals may affect improperly installed or inadequately shielded electronic system in motor vehicles.

.EXPOSURE TO RF ENERGY

Use only the supplied or an approved replacement antenna. Do not touch the antenna unnecessarily when the phone is in use. Do not move the antenna close to, or touching any exposed part of the body when making a call.

SAFETY INFORMATION FOR RF EXPOSURE

Body worn operation

This device was tested for typical body-worn operations with the back of the phone kept 15 mm. from the body. To maintain compliance with FCC RF exposure requirements, use only belt-clips, holsters or similar accessories that maintain a 15 mm. separation distance between the user's body and the back of the phone, including the antenna. The use of belt-clips, holsters and similar accessories should not contain metallic components in its assembly. The use of accessories that do not satisfy these requirements may not comply with FCC RF exposure requirements, and should be avoided.

SAR INFORMATION

THIS MODEL PHONE MEETS THE GOVERNMENT'S REQUIREMENTS FOR EXPOSURE TO RADIO WAVES.

Your wireless phone is a radio transmitter and receiver. It is designed and manufactured not to exceed the emission limits for exposure to radiofrequency (RF) energy set by the Federal Communications Commission of the U.S. Government. These limits are part of comprehensive guidelines and establish permitted levels of RF energy for the general population. The guidelines are based on standards that were developed by independent scientific organizations through periodic and thorough evaluation of scientific studies. The standards include a substantial safety margin designed to assure the safety of all persons, regardless of age and health. The exposure standard for wireless mobile phones employs a unit of measurement known as the Specific Absorption Rate, or SAR. The SAR limit set by the FCC is 1.6 W/kg. *

Tests for SAR are conducted with the phone transmitting at its highest certified power level in all tested frequency bands. Although the SAR is determined at the highest certified power level, the actual SAR level of the phone while operating can be well below the maximum value. This is because the phone is designed to operate at multiple power levels so as to use only the power required to reach the network. In general, the closer you are to a wireless base station antenna, the lower the power output. Before a phone model is available for sale to the public, it must be tested and certified to the FCC that it does not exceed the limit established by the government adopted requirement for safe exposure. The tests are performed in positions and locations (e.g., at the ear and worn on the body) as required by the FCC for each model. The highest SAR value for this model phone when tested for use at the ear is **1.12 W/Kg** and when worn on the body, as described in this user guide, is **0.457 W/Kg**. (Body-worn measurements differ among phone models, depending upon available accessories and FCC requirements). While there may be differences between the SAR levels of various phones and at various positions, they all meet the government requirement for safe exposure. The FCC has granted an Equipment Authorization for this model phone with all reported SAR levels evaluated as in compliance with the FCC RF exposure guidelines. SAR information on this model phone is on file with the FCC and can be found under the Display Grant section of <http://www.fcc.gov/oet/fccid> after searching on **FCC ID: YY3-NAUTIZX3**. Additional information on Specific Absorption Rates (SAR) can be found on the Cellular Telecommunications Industry Association (CTIA) web-site at <http://www.wow-com.com>. * In the United States and Canada, the SAR limit for mobile phones used by the public is 1.6 watts/kg (W/kg) averaged over one gram of tissue. The standard incorporates a substantial margin of safety to give additional protection for the public and to account for any variations in measurements.

U.S.A.

U.S.FEDERAL COMMUNICATIONS COMMISSION RADIO FREQUENCY INTERFERENCE STATEMENT

INFORMATION TO THE USER

NOTE : This equipment has been tested and found to comply with the limits for a Class B digital device pursuant to Part 15 of the FCC Rules. These limits are designed to provide reasonable protection against harmful Interference in a residential installation This equipment generates, uses, and can radiate radio frequency energy and, if Not installed and used in accordance with the instructions, may cause harmful Interference to radio communications. However, there is no guarantee that interference will not occur in a particular Installation. If this equipment does cause harmful interference to radio or television reception, which can be determined by turning the equipment off and on, the user is encouraged to try to correct the interference by one or more of the following measures:

- *- Reorient or relocate the receiving antenna.
- . Increase the separation between the equipment and receiver.
- *- Connect the equipment into an outlet of a circuit different from that to which the receiver is connected.
- *- Consult the dealer or an experienced radio/TV technician for assistance.

Changes or modification not expressly approved by the party responsible for Compliance could void the user's authority to operate the equipment. Connecting of peripherals requires the use of grounded shielded signal cables.

FCC Compliance Information

This device complies with Part 15 of FCC Rules.

Operation is subject to the following two conditions:

- (1) This device may not cause harmful interference, and
- (2) This device must accept any interference received.
Including interference that may cause undesired operation.