

System Check_H750_190608

DUT: Dipole 750 MHz D750V3;

Communication System: UID 0, CW (0); Frequency: 750 MHz; Duty Cycle: 1:1
Medium parameters used: $f = 750$ MHz; $\sigma = 0.899$ S/m; $\epsilon_r = 42.071$; $\rho = 1000$ kg/m³
Ambient Temperature : 23.2 °C; Liquid Temperature : 22.3 °C

DASY Configuration:

- Probe: EX3DV4 - SN7346; ConvF(10.19, 10.19, 10.19); Calibrated: 2019/4/25;
- Sensor-Surface: 1.4mm (Mechanical Surface Detection), $z = 1.0, 31.0$
- Electronics: DAE4 Sn917; Calibrated: 2018/12/7
- Phantom: ELI V5.0 (20deg probe tilt); Type: QD OVA 002 AA; Serial: 1240
- DASY52 52.8.8(1258); SEMCAD X 14.6.10(7373)

Area Scan (7x13x1): Measurement grid: $dx=15$ mm, $dy=15$ mm

Maximum value of SAR (measured) = 2.40 W/kg

Zoom Scan (5x5x7)/Cube 0: Measurement grid: $dx=8$ mm, $dy=8$ mm, $dz=5$ mm

Reference Value = 52.51 V/m; Power Drift = 0.00 dB

Peak SAR (extrapolated) = 2.91 W/kg

SAR(1 g) = 1.99 W/kg; SAR(10 g) = 1.35 W/kg

Maximum value of SAR (measured) = 2.49 W/kg

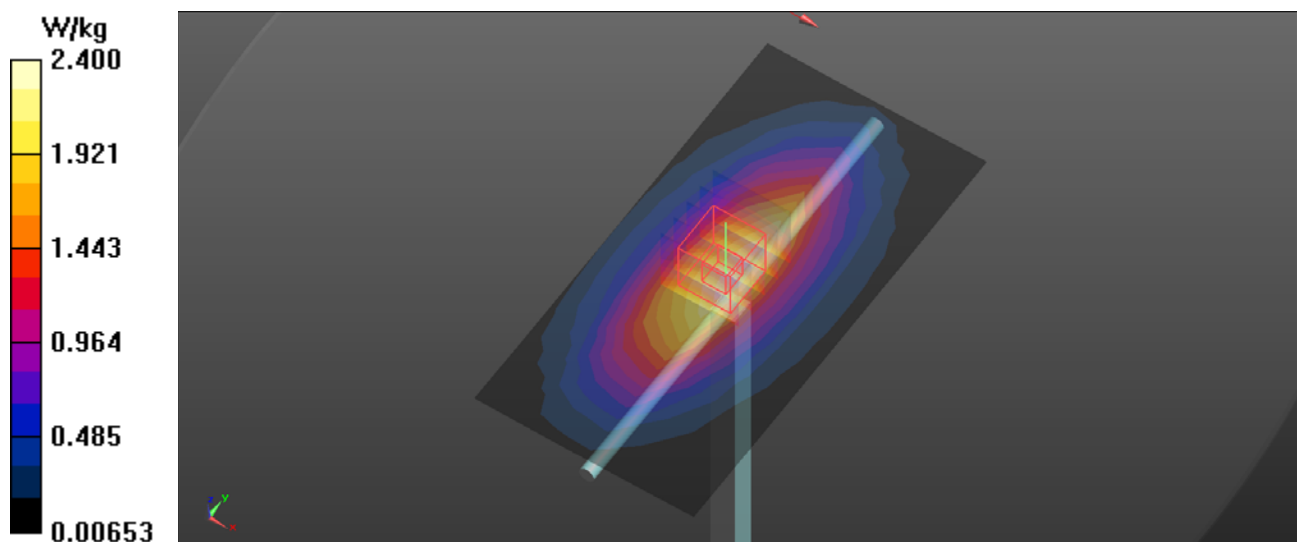

System Check_H835_190608

DUT: Dipole 835 MHz D835V2;

Communication System: UID 0, CW (0); Frequency: 835 MHz; Duty Cycle: 1:1
Medium parameters used: $f = 835$ MHz; $\sigma = 0.902$ S/m; $\epsilon_r = 42.995$; $\rho = 1000$ kg/m³
Ambient Temperature : 23.2 °C; Liquid Temperature : 22.2 °C

DASY Configuration:

- Probe: EX3DV4 - SN7369; ConvF(10.16, 10.16, 10.16); Calibrated: 2017/8/24;
- Sensor-Surface: 1.4mm (Mechanical Surface Detection), $z = 1.0, 31.0$
- Electronics: DAE4 Sn1486; Calibrated: 2017/8/17
- Phantom: ELI V5.0 (20deg probe tilt); Type: QD OVA 002 AA; Serial: 1240
- DASY52 52.8.8(1258); SEMCAD X 14.6.10(7373)

Area Scan (7x13x1): Measurement grid: $dx=15$ mm, $dy=15$ mm

Maximum value of SAR (measured) = 2.67 W/kg

Zoom Scan (5x5x7)/Cube 0: Measurement grid: $dx=8$ mm, $dy=8$ mm, $dz=5$ mm

Reference Value = 55.62 V/m; Power Drift = -0.02 dB

Peak SAR (extrapolated) = 3.15 W/kg

SAR(1 g) = 2.16 W/kg; SAR(10 g) = 1.44 W/kg

Maximum value of SAR (measured) = 2.71 W/kg

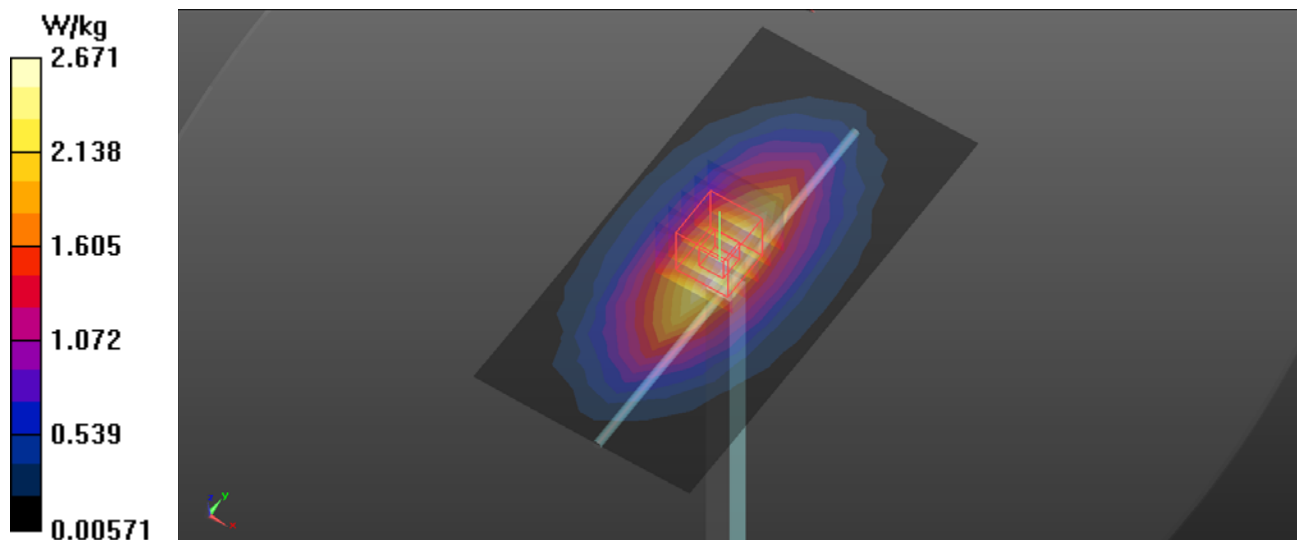

System Check_H1750_190608

DUT: Dipole 1750 MHz D1750V2;

Communication System: UID 0, CW (0); Frequency: 1750 MHz; Duty Cycle: 1:1
Medium parameters used: $f = 1750$ MHz; $\sigma = 1.327$ S/m; $\epsilon_r = 41.326$; $\rho = 1000$ kg/m³
Ambient Temperature : 23.1 °C; Liquid Temperature : 22.1 °C

DASY Configuration:

- Probe: EX3DV4 - SN7346; ConvF(8.5, 8.5, 8.5); Calibrated: 2019/4/25;
- Sensor-Surface: 1.4mm (Mechanical Surface Detection), $z = 1.0, 31.0$
- Electronics: DAE4 Sn917; Calibrated: 2018/12/7
- Phantom: ELI V5.0 (20deg probe tilt); Type: QD OVA 002 AA; Serial: 1240
- DASY52 52.8.8(1258); SEMCAD X 14.6.10(7373)

Area Scan (7x7x1): Measurement grid: $dx=15$ mm, $dy=15$ mm

Maximum value of SAR (measured) = 11.9 W/kg

Zoom Scan (5x5x7)/Cube 0: Measurement grid: $dx=8$ mm, $dy=8$ mm, $dz=5$ mm

Reference Value = 96.32 V/m; Power Drift = 0.01 dB

Peak SAR (extrapolated) = 15.4 W/kg

SAR(1 g) = 8.62 W/kg; SAR(10 g) = 4.54 W/kg

Maximum value of SAR (measured) = 12.1 W/kg

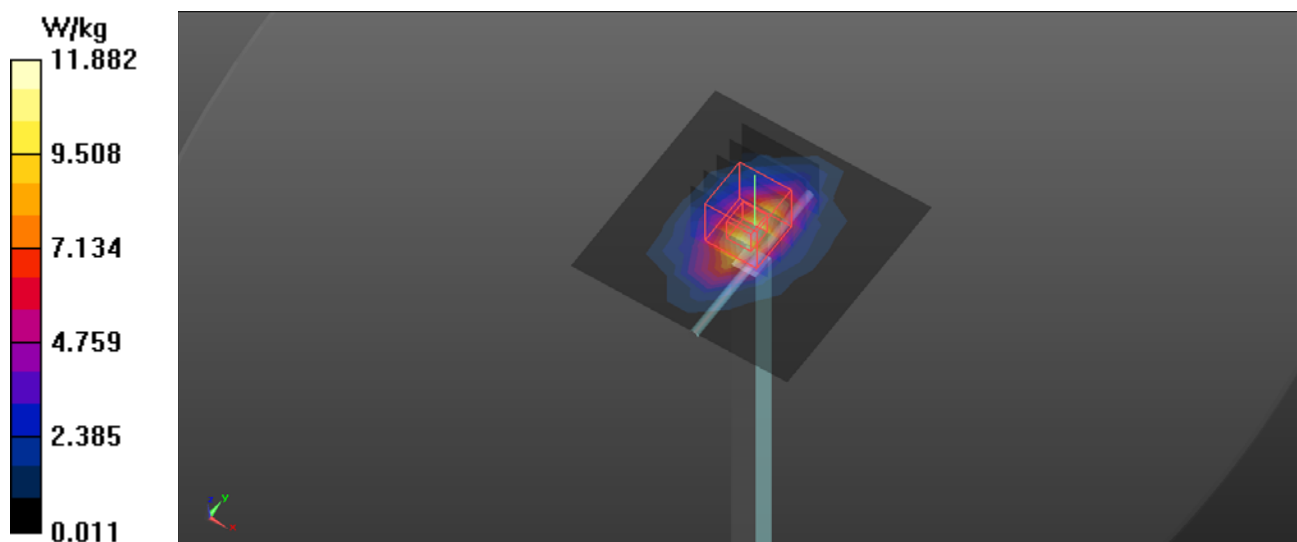

System Check_H1900_190429

DUT: Dipole 1900 MHz D1900V2;

Communication System: UID 0, CW (0); Frequency: 1900 MHz; Duty Cycle: 1:1
Medium parameters used: $f = 1900$ MHz; $\sigma = 1.412$ S/m; $\epsilon_r = 41.054$; $\rho = 1000$ kg/m³
Ambient Temperature : 23.2 °C; Liquid Temperature : 22.5 °C

DASY Configuration:

- Probe: EX3DV4 - SN3685; ConvF(7.21, 7.21, 7.21); Calibrated: 2019/3/25;
- Sensor-Surface: 1.4mm (Mechanical Surface Detection), $z = 1.0, 31.0$
- Electronics: DAE4 Sn1486; Calibrated: 2018/9/18
- Phantom: ELI V5.0 (20deg probe tilt); Type: QD OVA 002 AA; Serial: 1240
- DASY52 52.8.8(1258); SEMCAD X 14.6.10(7373)

Area Scan (7x7x1): Measurement grid: $dx=15$ mm, $dy=15$ mm

Maximum value of SAR (measured) = 14.3 W/kg

Zoom Scan (5x5x7)/Cube 0: Measurement grid: $dx=8$ mm, $dy=8$ mm, $dz=5$ mm

Reference Value = 98.00 V/m; Power Drift = 0.03 dB

Peak SAR (extrapolated) = 18.6 W/kg

SAR(1 g) = 10.1 W/kg; SAR(10 g) = 5.33 W/kg

Maximum value of SAR (measured) = 15.6 W/kg

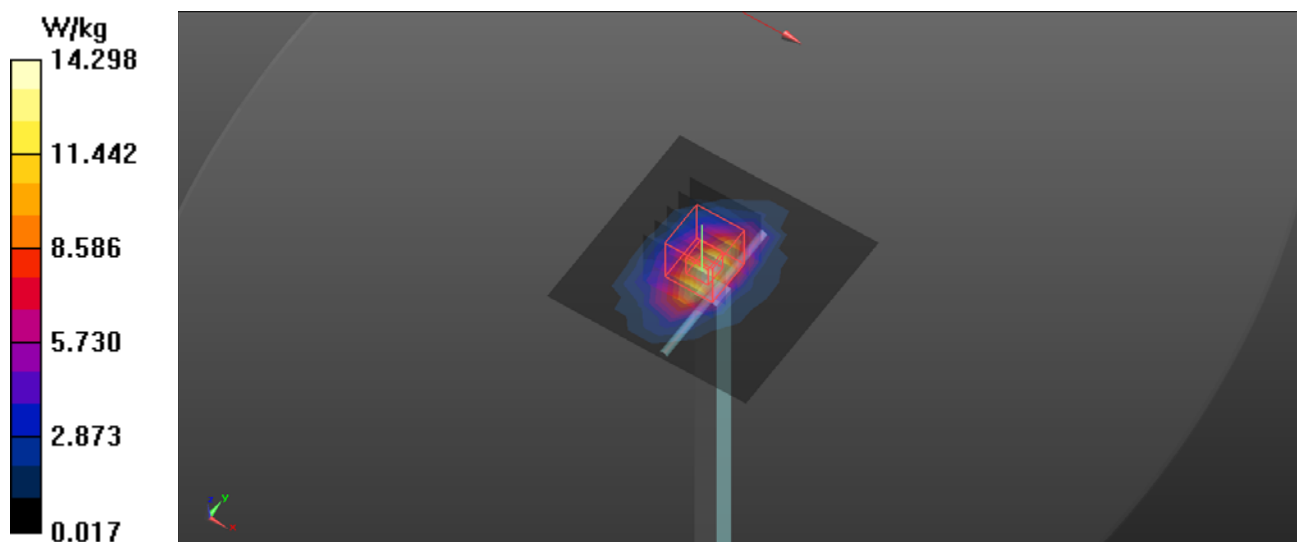

System Check_H1900_190608

DUT: Dipole 1900 MHz D1900V2;

Communication System: UID 0, CW (0); Frequency: 1900 MHz; Duty Cycle: 1:1
Medium parameters used: $f = 1900$ MHz; $\sigma = 1.414$ S/m; $\epsilon_r = 41.293$; $\rho = 1000$ kg/m³
Ambient Temperature : 23.2 °C; Liquid Temperature : 22.2 °C

DASY Configuration:

- Probe: EX3DV4 - SN7346; ConvF(8.07, 8.07, 8.07); Calibrated: 2019/4/25;
- Sensor-Surface: 1.4mm (Mechanical Surface Detection), $z = 1.0, 31.0$
- Electronics: DAE4 Sn917; Calibrated: 2018/12/7
- Phantom: ELI V5.0 (20deg probe tilt); Type: QD OVA 002 AA; Serial: 1240
- DASY52 52.8.8(1258); SEMCAD X 14.6.10(7373)

Area Scan (7x7x1): Measurement grid: $dx=15$ mm, $dy=15$ mm

Maximum value of SAR (measured) = 12.9 W/kg

Zoom Scan (5x5x7)/Cube 0: Measurement grid: $dx=8$ mm, $dy=8$ mm, $dz=5$ mm

Reference Value = 93.45 V/m; Power Drift = 0.03 dB

Peak SAR (extrapolated) = 16.8 W/kg

SAR(1 g) = 9.22 W/kg; SAR(10 g) = 4.84 W/kg

Maximum value of SAR (measured) = 14.1 W/kg

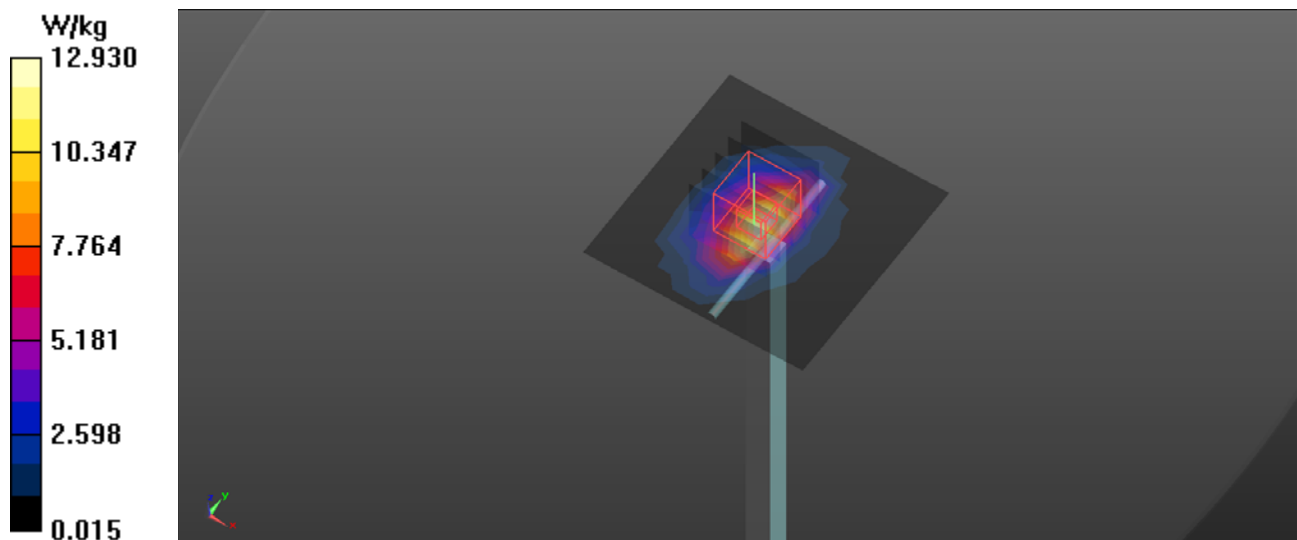

System Check_H2450_190529

DUT: Dipole 2450 MHz D2450V2;

Communication System: UID 0, CW (0); Frequency: 2450 MHz; Duty Cycle: 1:1

Medium parameters used (interpolated): $f = 2450$ MHz; $\sigma = 1.84$ S/m; $\epsilon_r = 40.655$; $\rho = 1000$ kg/m³

Ambient Temperature : 23.1 °C; Liquid Temperature : 22.3 °C

DASY Configuration:

- Probe: EX3DV4 - SN3685; ConvF(6.63, 6.63, 6.63) @ 2450 MHz; Calibrated: 2019/3/25
- Sensor-Surface: 1.4mm (Mechanical Surface Detection), $z = 1.0, 31.0$
- Electronics: DAE4 Sn878; Calibrated: 2018/12/12
- Phantom: ELI V5.0 (20deg probe tilt); Type: QD OVA 002 AA; Serial: 1240
- DASY52 52.10.2(1504); SEMCAD X 14.6.12(7470)

Area Scan (9x9x1): Measurement grid: $dx=12$ mm, $dy=12$ mm

Maximum value of SAR (measured) = 20.1 W/kg

Zoom Scan (7x7x7)/Cube 0: Measurement grid: $dx=5$ mm, $dy=5$ mm, $dz=5$ mm

Reference Value = 106.5 V/m; Power Drift = 0.17 dB

Peak SAR (extrapolated) = 27.4 W/kg

SAR(1 g) = 13.6 W/kg; SAR(10 g) = 6.52 W/kg

Maximum value of SAR (measured) = 21.1 W/kg

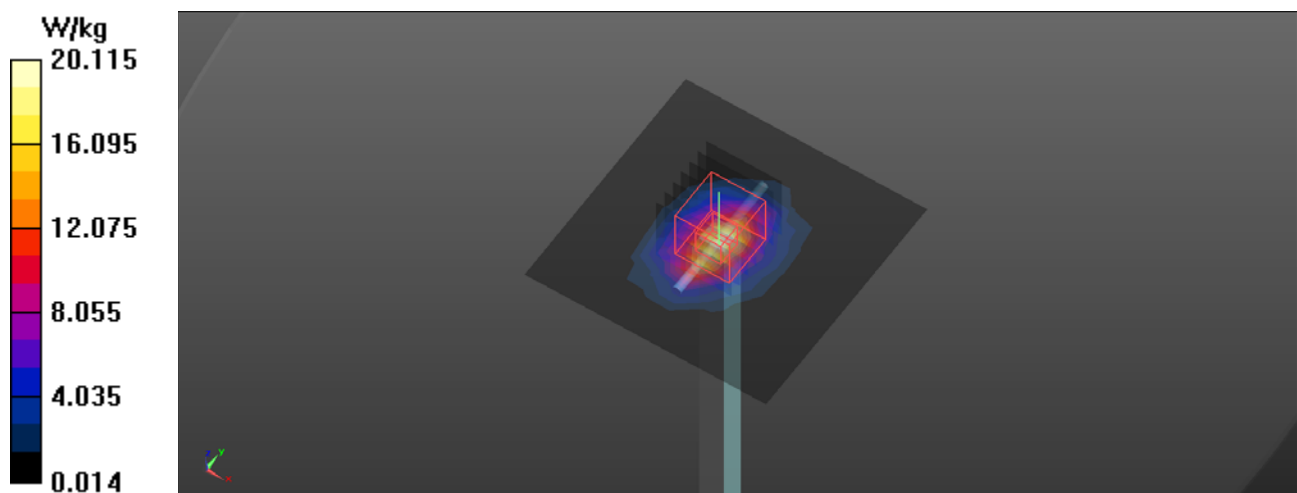

System Check_H2450_190617

DUT: Dipole 2450 MHz D2450V2;

Communication System: UID 0, CW (0); Frequency: 2450 MHz; Duty Cycle: 1:1
Medium parameters used: $f = 2450$ MHz; $\sigma = 1.841$ S/m; $\epsilon_r = 40.753$; $\rho = 1000$ kg/m³
Ambient Temperature : 23.1 °C; Liquid Temperature : 22.2 °C

DASY Configuration:

- Probe: EX3DV4 - SN7346; ConvF(7.5, 7.5, 7.5); Calibrated: 2019/4/25;
- Sensor-Surface: 1.4mm (Mechanical Surface Detection), $z = 1.0, 31.0$
- Electronics: DAE4 Sn917; Calibrated: 2018/12/7
- Phantom: ELI V5.0 (20deg probe tilt); Type: QD OVA 002 AA; Serial: 1240
- DASY52 52.8.8(1258); SEMCAD X 14.6.10(7373)

Area Scan (9x9x1): Measurement grid: $dx=12$ mm, $dy=12$ mm

Maximum value of SAR (measured) = 19.7 W/kg

Zoom Scan (7x7x7)/Cube 0: Measurement grid: $dx=5$ mm, $dy=5$ mm, $dz=5$ mm

Reference Value = 104.9 V/m; Power Drift = -0.06 dB

Peak SAR (extrapolated) = 25.9 W/kg

SAR(1 g) = 12.9 W/kg; SAR(10 g) = 6.05 W/kg

Maximum value of SAR (measured) = 19.5 W/kg

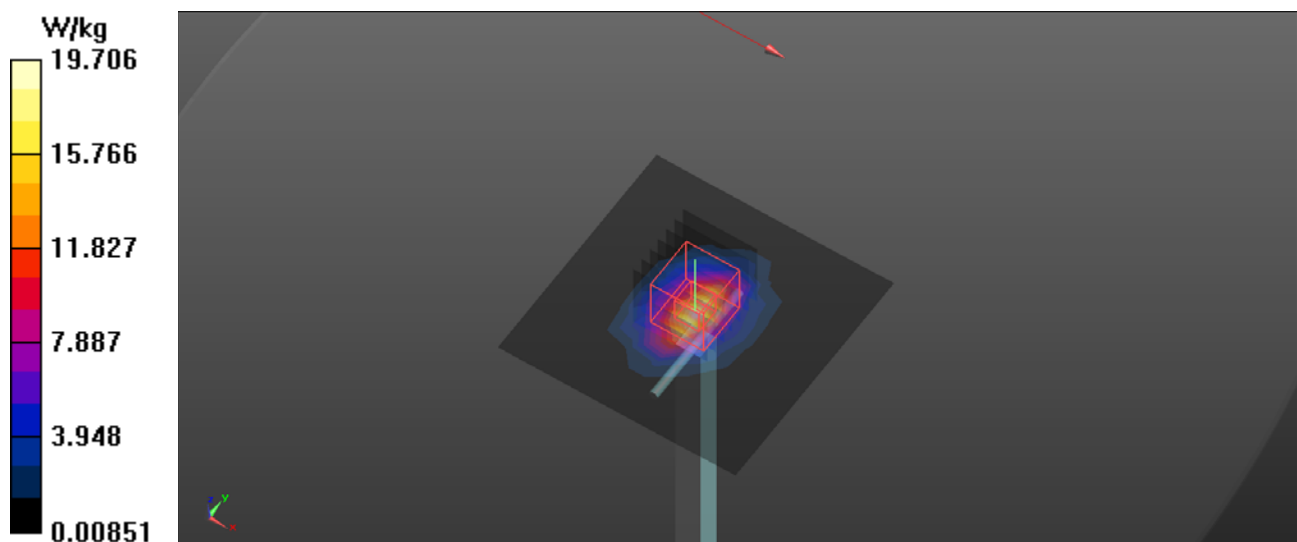

System Check_H5300_190604

DUT: Dipole D5GHzV2;

Communication System: UID 0, CW (0); Frequency: 5300 MHz; Duty Cycle: 1:1
Medium parameters used: $f = 5300$ MHz; $\sigma = 4.863$ S/m; $\epsilon_r = 35.184$; $\rho = 1000$ kg/m³
Ambient Temperature : 23.1 °C; Liquid Temperature : 22.4 °C

DASY Configuration:

- Probe: EX3DV4 - SN7346; ConvF(5.36, 5.36, 5.36); Calibrated: 2019/4/25;
- Sensor-Surface: 1.4mm (Mechanical Surface Detection), $z = 1.0, 23.0$
- Electronics: DAE4 Sn917; Calibrated: 2018/12/7
- Phantom: ELI V5.0 (20deg probe tilt); Type: QD OVA 002 AA; Serial: 1240
- DASY52 52.8.8(1258); SEMCAD X 14.6.10(7373)

Area Scan (10x10x1): Measurement grid: $dx=10$ mm, $dy=10$ mm
Maximum value of SAR (measured) = 11.7 W/kg

Zoom Scan (7x7x12)/Cube 0: Measurement grid: $dx=4$ mm, $dy=4$ mm, $dz=2$ mm
Reference Value = 59.66 V/m; Power Drift = 0.05 dB
Peak SAR (extrapolated) = 34.9 W/kg
SAR(1 g) = 7.79 W/kg; SAR(10 g) = 2.18 W/kg
Maximum value of SAR (measured) = 16.8 W/kg

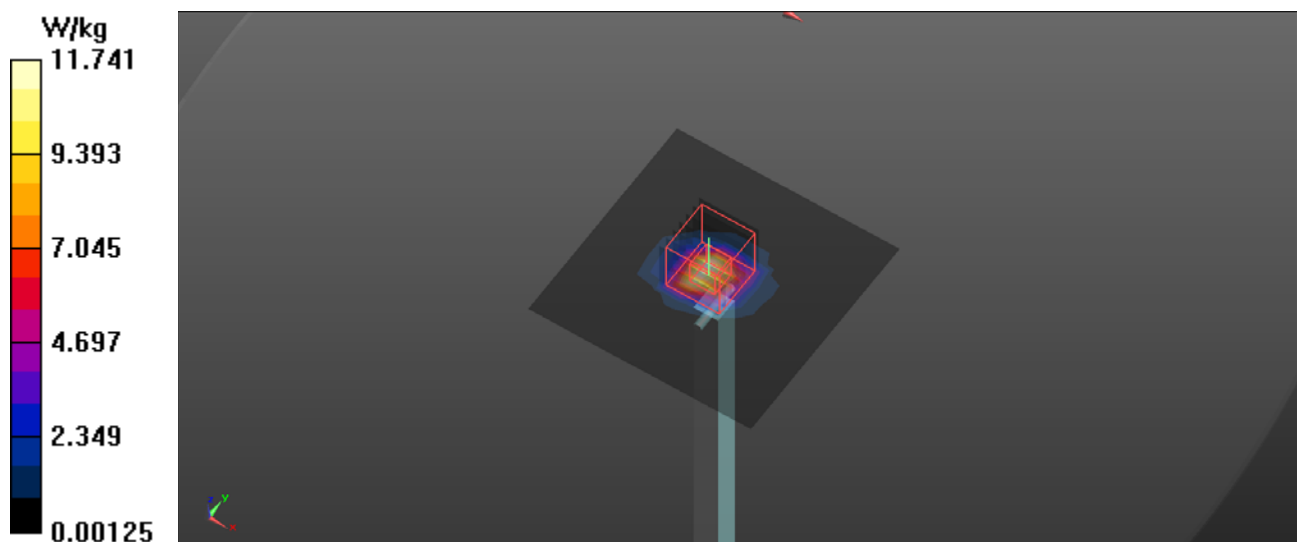

System Check_H5600_190604

DUT: Dipole D5GHzV2;

Communication System: UID 0, CW (0); Frequency: 5600 MHz; Duty Cycle: 1:1
Medium parameters used: $f = 5600$ MHz; $\sigma = 5.218$ S/m; $\epsilon_r = 34.456$; $\rho = 1000$ kg/m³
Ambient Temperature : 23.1 °C; Liquid Temperature : 22.4 °C

DASY Configuration:

- Probe: EX3DV4 - SN7346; ConvF(4.75, 4.75, 4.75); Calibrated: 2019/4/25;
- Sensor-Surface: 1.4mm (Mechanical Surface Detection), $z = 1.0, 23.0$
- Electronics: DAE4 Sn917; Calibrated: 2018/12/7
- Phantom: ELI V5.0 (20deg probe tilt); Type: QD OVA 002 AA; Serial: 1240
- DASY52 52.8.8(1258); SEMCAD X 14.6.10(7373)

Area Scan (10x10x1): Measurement grid: $dx=10$ mm, $dy=10$ mm

Maximum value of SAR (measured) = 10.5 W/kg

Zoom Scan (7x7x12)/Cube 0: Measurement grid: $dx=4$ mm, $dy=4$ mm, $dz=2$ mm

Reference Value = 59.66 V/m; Power Drift = 0.04 dB

Peak SAR (extrapolated) = 36.2 W/kg

SAR(1 g) = 7.92 W/kg; SAR(10 g) = 2.22 W/kg

Maximum value of SAR (measured) = 17.0 W/kg

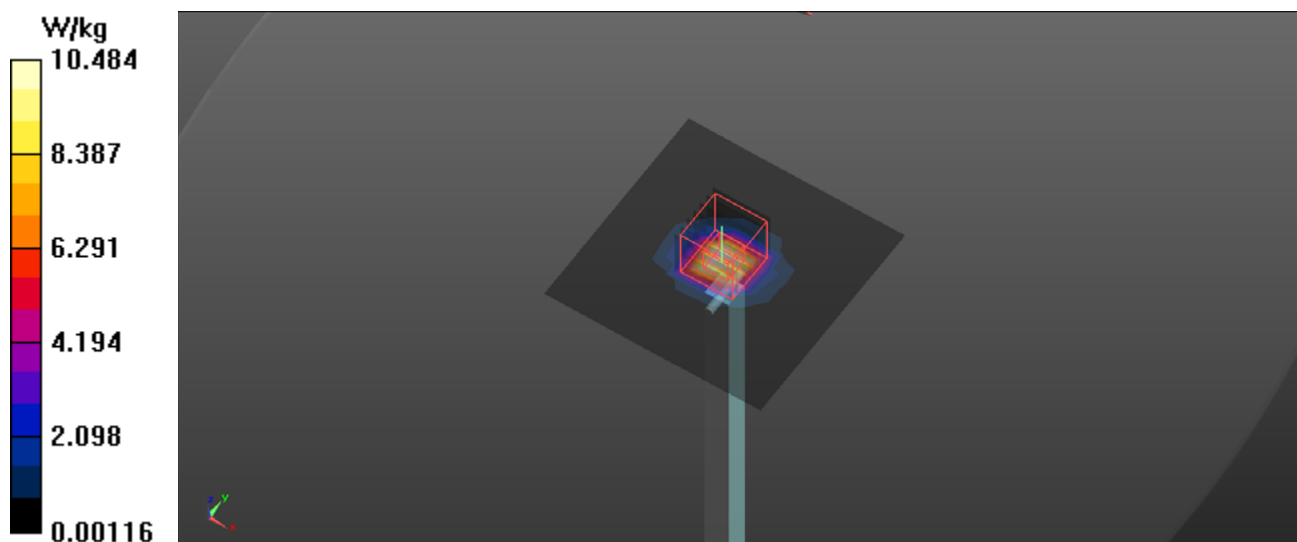

System Check_H5800_190604

DUT: Dipole D5GHzV2;

Communication System: UID 0, CW (0); Frequency: 5800 MHz; Duty Cycle: 1:1
Medium parameters used: $f = 5800$ MHz; $\sigma = 5.455$ S/m; $\epsilon_r = 34$; $\rho = 1000$ kg/m³
Ambient Temperature : 23.1 °C; Liquid Temperature : 22.4 °C

DASY Configuration:

- Probe: EX3DV4 - SN7346; ConvF(4.78, 4.78, 4.78); Calibrated: 2019/4/25;
- Sensor-Surface: 1.4mm (Mechanical Surface Detection), $z = 1.0, 23.0$
- Electronics: DAE4 Sn917; Calibrated: 2018/12/7
- Phantom: ELI V5.0 (20deg probe tilt); Type: QD OVA 002 AA; Serial: 1240
- DASY52 52.8.8(1258); SEMCAD X 14.6.10(7373)

Area Scan (10x10x1): Measurement grid: $dx=10$ mm, $dy=10$ mm
Maximum value of SAR (measured) = 12.2 W/kg

Zoom Scan (7x7x12)/Cube 0: Measurement grid: $dx=4$ mm, $dy=4$ mm, $dz=2$ mm
Reference Value = 56.40 V/m; Power Drift = -0.16 dB
Peak SAR (extrapolated) = 34.0 W/kg
SAR(1 g) = 7.55 W/kg; SAR(10 g) = 2.19 W/kg
Maximum value of SAR (measured) = 16.1 W/kg

