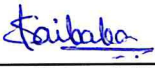

Produkte
Products

Prüfbericht - Nr.: 19660246 001		Seite 1 von 139			
<i>Test Report No.:</i>		<i>Page 1 of 139</i>			
Auftraggeber: <i>Client:</i>	HANDHELD GROUP AB Kinnegatan 17 A 531 33 Lidköping Sweden Tel: +46 (0) 510-54 71 70				
Gegenstand der Prüfung: <i>Test item:</i>	Rugged 7" Tablet				
Bezeichnung: <i>Identification:</i>	118207	Serien-Nr.: <i>Serial No.</i>	Engineering Sample		
Wareneingangs-Nr.: <i>Receipt No.:</i>	1803156247	Eingangsdatum: <i>Date of receipt:</i>	20.07.2016		
Prüfört: <i>Testing location:</i>	Refer Page 4 of 139 for test facilities				
Prüfgrundlage: <i>Test specification:</i>	FCC Part 2, Part 22H, Part 24E , Part 27 & RSS 132 Issue 3, RSS 133 Issue 6 & RSS139 Issue 3, RSS 310 Issue 1, ANSI C63.10-2013 & TIA-603-D-2010				
Prüfergebnis: <i>Test Result:</i>	Der Prüfgegenstand entspricht oben genannter Prüfgrundlage(n). <i>The test items passed the test specification(s).</i>				
Prüflaboratorium: <i>Testing Laboratory:</i>	TÜV Rheinland (India) Pvt. Ltd. 82/A, 3rd Main, West Wing, Electronic City Phase 1 Hosur Road, Bangalore – 560 100. India FCC Registration No.: 176555 & IC OATS Reg. Number.: 3466E				
geprüft / tested by:	kontrolliert / reviewed by:				
17.10.2016	Shrikanth S Naik Sr.Engineer		23.11.2016	Saibaba Siddapur Assistant Manager	
Datum <i>Date</i>	Name/Stellung <i>Name/Position</i>	Unterschrift <i>Signature</i>	Datum <i>Date</i>	Name/Stellung <i>Name/Position</i>	Unterschrift <i>Signature</i>
Sonstiges / Other Aspects: FCC ID :YY3-118207 & IC: 11695A-118207					
Abkürzungen:	P(ass) = entspricht Prüfgrundlage	Abbreviations:	P(ass) = passed		
	F(ail) = entspricht nicht Prüfgrundlage		F(ail) = failed		
	N/A = nicht anwendbar		N/A = not applicable		
	N/T = nicht getestet		N/T = not tested		
Dieser Prüfbericht bezieht sich nur auf das o.g. Prüfmuster und darf ohne Genehmigung der Prüfstelle nicht auszugsweise vervielfältigt werden. Dieser Bericht berechtigt nicht zur Verwendung eines Prüfzeichens. <i>This test report relates to the a. m. test sample. Without permission of the test center this test report is not permitted to be duplicated in extracts. This test report does not entitle to carry any safety mark on this or similar products.</i>					

TÜV Rheinland India Pvt. Ltd. 82/A, 3rd Main, West Wing Electronic City Phase 1, Hosur Road, Bangalore-560100, India

 Tel.: +9180 6723 3500 · Fax: +9180 6723 3542 · Web: www.tuv.com

Test Result Summary

Test Item	Clause		Result
	FCC	IC	
RF Output Power – Conducted Mode	FCC Part 2.1046	RSS 132 Issue 3 section 5.4, SRSP-503 section 5.1.3 & RSS 133 Issue 6 section 4.1/6.4, SRSP-510.5.1.2 & RSS 139 Issue 3 section 6.5, RSS-130 Issue 1 section 4.4	Pass
99% Occupied Bandwidth & 26dB Emission Bandwidth	FCC Part 2.1049	RSS-Gen Issue 4 section 6.6	Pass
Band Edge Compliance	FCC Part 2.1051, 22.917(a)(b), 24.238(a)(b), 27.53(h)	RSS 132 Issue 3 section 5.5(i)(ii), & RSS 133 Issue 6 section 6.5.1 (i)(ii) & RSS 139 Issue 3 section 6.6(i)(ii), RSS-130 Issue 1 section 4.6	Pass
Conducted Spurious Emission	FCC Part 2.1051, 2.1057, 22.917(a)(b), 24.238(a)(b), 27.53(h)	RSS 132 Issue 3 section 5.5 (i)(ii) & RSS 133 Issue 6 section 6.5.1 (i)(ii) & RSS 139 Issue 3 section 6.6(i)(ii), RSS-130 Issue 1 section 4.6	Pass
Frequency Stability	FCC Part 2.1055(a) (1), 22.355, 24.235, 27.54	RSS 132 Issue 3 section 5.3 & RSS 133 Issue 6 section 6.3 & RSS 139 Issue 3 section 6.4, RSS-130 Issue 1 section 4.3	Pass
RF Output Power (ERP/EIRP) – Radiated Mode	FCC Part 2.1046(a), 22.913(a) (2) 24.232(c), 27.50(d) (4)	RSS 132 Issue 3 section 5.4, SRSP-503 section 5.1.3 & RSS 133 Issue 6 section 4.1/6.4, SRSP-510.5.1.2 & RSS 139 Issue 3 section 6.5, RSS-130 Issue 1 section 4.4	Pass
Field Strength of Spurious Radiation	FCC Part 2.1053(a), 22.917(a)(b), 24.238(a)(b) 27.53(h)	RSS 132 Issue 3 section 5.5 (i)(ii) & RSS 133 Issue 6 section 6.5.1 (i)(ii) & RSS 139 Issue 3 section 6.6(i)(ii), RSS-130 Issue 1 section 4.6	Pass

Note: Testing Performed according to the procedure given in 971168 D01 Power Meas License Digital Systems v02r02.

Content

List of Test and Measurement Instruments.....	4
General Product Information	5
Product Function and Intended Use.....	5
Ratings and System Details.....	5
Test Set-up and Operation Mode.....	8
Principle of Configuration Selection	9
Test Operation and Test Software	9
Test Modes – Data Rates and Modulations	9
Operational description	10
Test Methodology	11
Test Results	11
RF Output Power – Conducted Mode.....	13
99% Occupied Bandwidth &	21
26dB Emission Bandwidth	21
Band Edge Measurement.....	62
Conducted Spurious Emission	91
Frequency Stability.....	129
RF Power (ERP/EIRP) – Radiated Mode	134
Field Strength of Spurious Radiation	137
Appendix 1: Test Setup Photo	
Appendix 2: EUT External Photo	
Appendix 3: EUT Internal Photo	
Appendix 4: FCC Label and Label Location	
Appendix 5: Block Diagram	
Appendix 6: Specification of EUT	
Appendix 7: Schematic Diagrams	
Appendix 8: Bill of Material	
Appendix 9: User Manual	
Appendix 10: SAR Test Report	

List of Test and Measurement Instruments

Equipment	Manufacturer	Model Name	Serial Number	Calibration Due Date	Periodicity	Used for Test Items
EMI Test Receiver	Rohde & Schwarz	ESU 40	100288	23.11.2016	Yearly	Spurious Radiated Emissions
Broadband Antenna	Frankonia	ALX-4000	ALX-4000-806	20.01.2017	Yearly	
Active Loop Antenna	Frankonia	LAX-10	LAX-10-800	22.12.2016	Yearly	
Broadband Horn Antenna	Frankonia	HAX-18	HAX18-802	14.03.2017	Yearly	
Double-Ridged Waveguide Horn Antenna	ETS Lindgren	116706	00107323	02.11.2016	Yearly	
Anechoic Chamber	Frankonia	-	-		-	
Spectrum Analyser	Agilent Technologies	E4407B	US41192772	23.04.2017	Yearly	Antenna - Port Conducted Tests
Signal Analyzer	Rohde & Schwarz	FSV7	101644	07.12.2016	Yearly	
Environmental Chamber	Envisys	EM80-40H	ET/022/14-15	09.06.2017	Yearly	
Wideband Radio Communication Tester	Rohde & Schwarz	CMW500	158345	26.09.2017	Yearly	

Testing Facilities:

TUV Rheinland (India) Private Limited
 108 , Beside ISBR Business School,
 Electronic city Phase I
 Bangalore - 560 100.

www.tuv.com

General Product Information

Product Function and Intended Use

The Algiz RT7 is a rugged tablet, designed for use by field personnel in demanding conditions. It integrates best-in-class connectivity with efficient computing and multimedia features. The tablet runs Android Lollipop (5.1.1) operating system, and comes pre-installed with many Google applications, including Google Play.

Ratings and System Details

Operating Frequency	Refer page 7 of 134
Modulation	QPSK , 16-QAM
Power Class	3 (23dBm)
Release	10
Modulation Type	QPSK , 16-QAM
Number of Antenna – Two	Primary Antenna – One Diversity Antenna - One
Antenna Gain and Antenna type	0dBi & Integrated Antenna
Supply Voltage to Product	Internal Battery Pack -> 3.7- 4.2 VDC & Adaptor 5VDC to EUT
Environmental	Storage Temperature -> -40°C to +70 °C Operating Temperature-> -20°C to 50°C in a humidity up to 95% noncondensing

Test Conditions:

Supply Voltage: 3.7- 4.2 VDC & Adaptor 5VDC to EUT

Environmental conditions:

Temperature: +25 °C RH: 62%

www.tuv.com

Equipment used for testing as identified in below Table.

Equipment Used for	S/N Number	IMEI No.	Hardware Version	Software version
Conducted Measurement on Antenna Port	6G010057	911381250014927 & 911381250014935	Engineering Sample	Android 5.1.1, LMY47V'
Radiated Mode Test	6G010310	911381250019983 & 911381250019991	Engineering Sample	Android 5.1.1, LMY47V'

Summary of Measured Power & Emission Designator:

FDD Band	Bandwidth	Maximum Power - Conducted Mode - QPSK (Pk)		Maximum Power - Conducted Mode - 16-QAM (Pk)		Output Power (dBm) - Radiated Mode -QPSK
		dBm	Watt	dBm	Watt	
2	5	26.25	0.42169	26.44	0.44055	22.16
	10	26.53	0.449779	26.73	0.47097	21.42
	15	26.59	0.45603	26.91	0.49090	20.89
	20	26.77	0.47533	27.24	0.52966	20.2
4	5	26.84	0.48305	26.54	0.45081	20.23
	10	26.71	0.46881	27.63	0.57942	18.95
	15	27.04	0.05082	27.12	0.51523	19.12
	20	26.68	0.46558	26.84	0.48305	17.58
5	5	25.99	0.39719	25.89	0.38815	17.86
	10	26.30	0.42657	26.35	0.43151	18.14
17	5	26.43	0.43954	26.14	0.41115	16.96
	10	26.61	0.45814	26.14	0.41115	16.75
13	10	25.94	0.392644	25.86	0.385478	17.93

Emission Designator Details

FDD Band	Bandwidth	Emission Designator (QPSK)	Emission Designator (16-QAM)
2	5	4M51G7D	4M54W7D
	10	8M94G7D	8M94W7D
	15	13M4G7D	13M4W7D
	20	17M9G7D	17M9W7D
4	5	4M53G7D	4M52W7D
	10	8M95G7D	8M95W7D
	15	13M5G7D	13M5W7D
	20	17M9G7D	17M9W7D
5	5	4M54G7D	4M53W7D
	10	8M96G7D	8M94W7D
17	5	4M52G7D	4M54W7D
	10	8M93G7D	8M91W7D
13	10	8M92G7D	8M91W7D

www.tuv.com

FDD bands Frequency Details:

FDD Band	Transmitter Frequency (Uplink) (MHz)	Receiver Frequency (Downlink) (MHz)
2	1850 – 1910	1930 – 1990
4	1710 – 1755	2110 – 2155
5	824 – 849	869 – 894
17	704 - 716	734 - 746

Frequency List of Low/Mid/High channel

LTE FDD Band 2				
Bandwidth	Channel/Frequency (MHz)	Low	Mid	High
5	Channel No.	18625	18900	19175
	Frequency	1852.5	1880	1907.5
10	Channel No.	18700	18900	19150
	Frequency	1860	1880	1905
15	Channel No.	18675	18900	19125
	Frequency	1857.5	1880	1902.5
20	Channel No.	18700	18900	19100
	Frequency	1860	1880	1900

LTE FDD Band 4				
Bandwidth	Channel/Frequency (MHz)	Low	Mid	High
5	Channel No.	19975	20175	20375
	Frequency	1712.5	1732.5	1752.5
10	Channel No.	20000	20175	20350
	Frequency	1715	1732.5	1750
15	Channel No.	20025	20175	20325
	Frequency	1717.5	1732.5	1747.5
20	Channel No.	20050	20175	20300
	Frequency	1720	1732.5	1745

LTE FDD Band 5				
Bandwidth	Channel/Frequency (MHz)	Low	Mid	High
5	Channel No.	20425	20525	20625
	Frequency	826.5	836.5	846.5
10	Channel No.	20450	20525	20600
	Frequency	829	836.5	844

www.tuv.com

LTE FDD Band 17				
Bandwidth	Channel/Frequency (MHz)	Low	Mid	High
5	Channel No.	23755	23790	23825
	Frequency	706.5	710	713.5
10	Channel No.	23780	23790	23800
	Frequency	709	710	711

LTE FDD Band 13				
Bandwidth	Channel/Frequency (MHz)	Low	Mid	High
10	Channel No.	23230	23230	23230
	Frequency	782	782	782

www.tuv.com

Test Set-up and Operation Mode

Principle of Configuration Selection

Transmission was enabled with help of CMW500 on low, mid and high channel

Test Operation and Test Software

No Special Test software used for enabling the Transmission, SIM inserted in EUT to communicate with CMW500 simulator

Special Accessories and Auxiliary Equipment

- None

Countermeasures to achieve EMC Compliance

A ferrite bead was used on the USB cable which is connected to the adaptor (accessory) closer to the DUT during testing. Refer appendix 1 for test setup photos.

Ferrite no. 742 711 12 & 742 717 33 (make: Würth Electronics).

Test Modes – Data Rates and Modulations

For Radiated spurious emissions, the tests were performed for all data rates and only worst case results are reported in this report.

Note: Product Rugged 7" Tablet has multiple protocols. All the supported wireless protocols and their respective test report numbers are mentioned in the below table.

Radio Protocol	Report Number
NFC	19660243 001
Wi-Fi (IEEE 802.11bgn)	19660240 001
BLE	19660242 001
Bluetooth (BDR+EDR)	19660241 001
GSM	19660244 001
W-CDMA	19660245 001

www.tuv.com

Operational description

Whether you're collecting data, crunching numbers or viewing graphics, the Algiz RT7's powerful Qualcomm quad-core processor provides reliable, uninterrupted work performance.

And the Algiz RT7 doesn't just run Android flawlessly — its capacitive touchscreen also enhances the Android experience with five-point multi-touch capability, 600-nit high-brightness sunlight readability and chemically strengthened glass.

Yet the Algiz RT7 also meets stringent MIL-STD-810G military standards for withstanding extreme temperatures, drops and vibrations, and its IP65 rating means it's waterproof and fully protected against sand and dust.

www.tuv.com

Test Methodology

Frequency Range 9 kHz -30 MHz

Test performed as per ANSI C63.10-2013 section 6.4

The loop Antenna was placed at 1m above the ground plane & EUT is 3 meters far from the measuring antenna. With 3m measurement distance, correction data were applied to the measured results. The test arrangement, measuring antenna guidelines and operational configurations in 6.3.1 and 6.3.2, shall be followed. The measurement antenna shall be positioned with its plane perpendicular to the ground at the Specified distance, when perpendicular to the ground plane, the lowest height of the magnetic antenna shall be 1 m above the ground and shall be positioned at the specified distance from the EUT. EUT & its associates are placed on non-conducting table of 0.8m height which is placed on the turn table, For each measurement antenna alignment, the EUT shall be rotated through 0° to 360° on a turntable. The report shall list worst case emission results, for each of the parallel & perpendicular orientations.

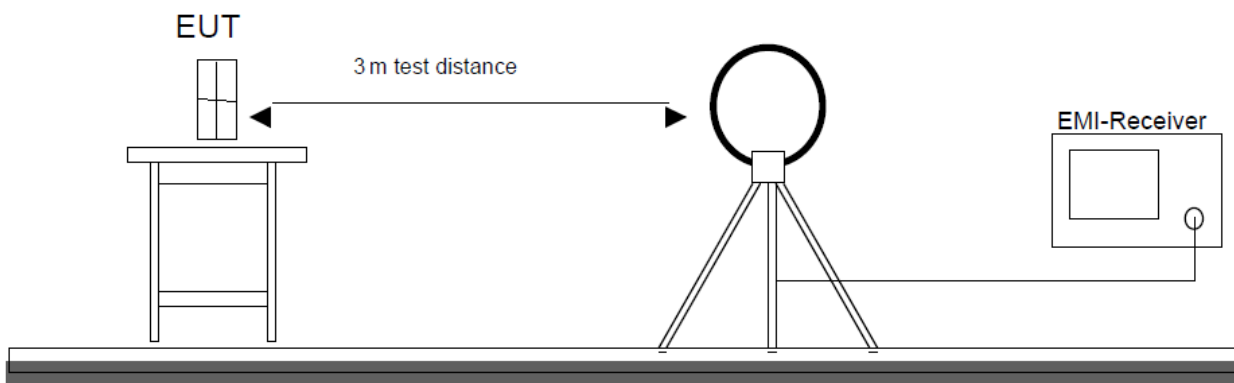

Frequency Range 30MHz to 10th harmonics of the highest fundamental frequency

Test performed as per ANSI/TIA-603-D-2010 Clause 2.2.12/17

ERP/EIRP Radiated Power & Radiated spurious emission test are performed as below.

The equipment under test is placed on non-conductive table at 3m away from the receive antenna in accordance with above mentioned standard. Turn table is rotated through 360 degree, and receiver antenna height is varied in order to determine the level of maximum emission. The maximum emission level and position of the maximized emission is recorded with use of spectrum analyzer.

The EUT is substituted by a substitution antenna. The substitute antenna is connected to a signal generator. Adjust the output level of the signal generator to get the same power recorded in with EUT and record the power level of Signal Generator. The cable loss at the test frequency should be compensated

www.tuv.com

The Power is calculated by the following formula

$$P_d \text{ (dBm)} = P_g \text{ (dBm)} - \text{Cable Loss (dB)} + \text{Antenna Gain (dB)}$$

Where

P_d is the dipole equivalent power.

P_g is the generator output power into the substitution antenna

These steps are repeated with the receiving antenna in the both vertical & horizontal polarization

Measurement Method

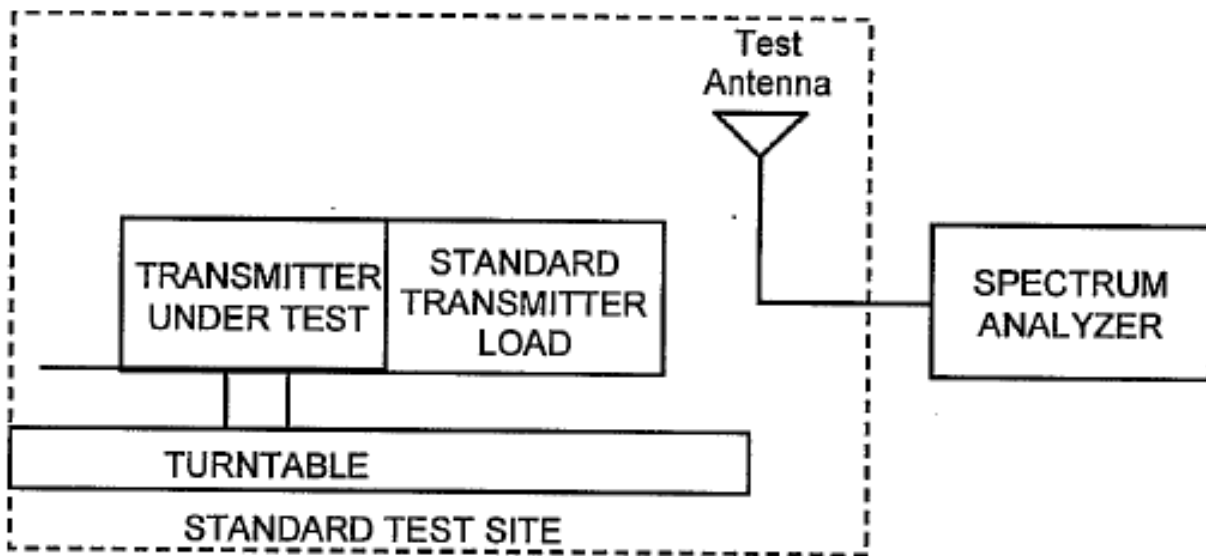

Substitute measurement method

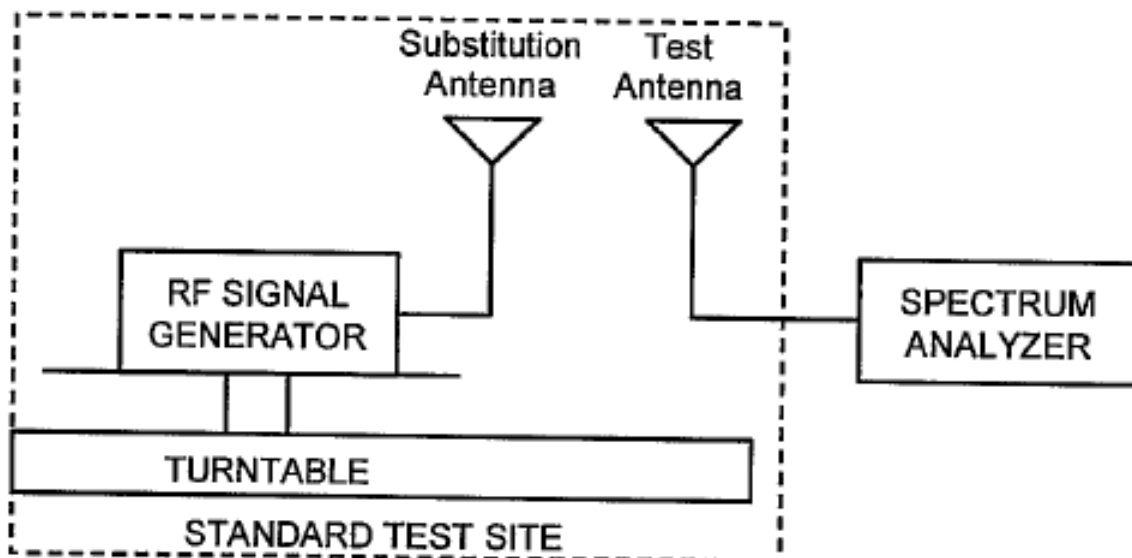

www.tuv.com

Test Results

RF Output Power – Conducted Mode Result

Pass

Specification	FCC Part 2.1046 & RSS 132 Issue 3 section 5.3, RSS 133 Issue 6 section 4.1/6.4, RSS 139 Issue 3 section 4.1/6.5, RSS 130 Issue 1 section 4.4
Measurement Bandwidth (RBW)	≥ OBW
Detector Function	Peak/Average

Test Setup:

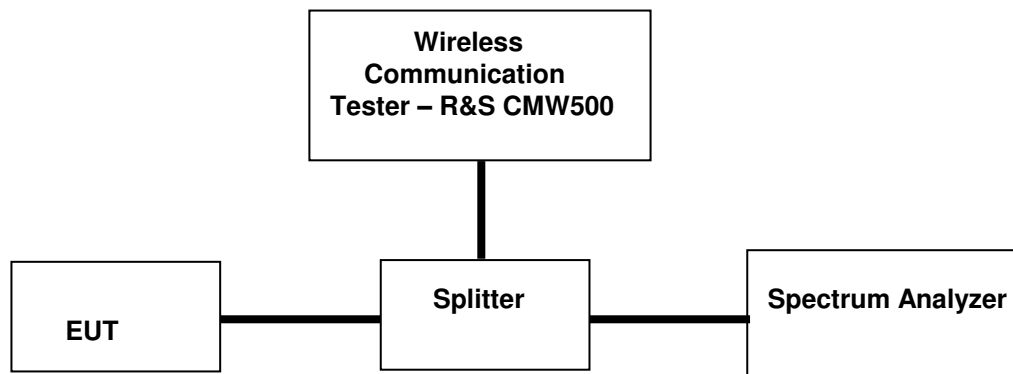

Note: For measurement of RF Output Power, section 5.1.1 & 5.2.1 & Measurement of Peak to Average Power Ratio method 5.7.2 in “971168 D01 Power Meas License Digital Systems v02r02” & Attenuator & Cable loss is included in the test results

Remark: For #1RB, verified for both Position Low & Position high & only worst case position low results are reported.

Note: Cable Loss (1.5dB) + Attenuator (30dB) are considered for Band 2
Cable Loss (1.3dB) + Attenuator (30dB) are considered for Band 4
Cable Loss (1.3dB) + Attenuator (30dB) are considered for Band 5
Cable Loss (0.7dB) + Attenuator (30dB) are considered for Band 17
Cable Loss (0.9dB) + Attenuator (30dBm) are considered for Band 13

PAPR – Peak to Average Power Ratio.

Test Results

FDD Band 2, Modulation- QPSK						
Channel Bandwidth (MHz)	Resource Block Allocation	Channel	Peak Output Power (dBm)	Average Output Power (dBm)	PAPR (dB)	PAPR Limit (dB)
5	1	Low	25.87	21.42	4.45	≤13
		Mid	26.25	21.93	4.32	≤13
		High	26.21	21.74	4.47	≤13
	50%	Low	25.5	20.74	4.76	≤13
		Mid	26.17	21.54	4.63	≤13
		High	26.06	21.28	4.78	≤13
	100%	Low	25.18	20.69	4.49	≤13
		Mid	25.72	21.42	4.30	≤13
		High	25.5	21.14	4.36	≤13
10	1	Low	26.08	20.64	5.44	≤13
		Mid	26.36	21.15	5.21	≤13
		High	26.53	21.40	5.13	≤13
	50%	Low	26.26	20.66	5.60	≤13
		Mid	26.09	21.46	4.63	≤13
		High	26.26	21.55	4.71	≤13
	100%	Low	25.75	20.70	5.05	≤13
		Mid	25.97	21.34	4.63	≤13
		High	25.92	21.47	4.45	≤13
15	1	Low	26.11	20.86	5.25	≤13
		Mid	26.59	21.51	5.08	≤13
		High	26.44	20.78	5.66	≤13
	50%	Low	25.74	20.55	5.19	≤13
		Mid	26.24	21.08	5.16	≤13
		High	26.44	21.26	5.18	≤13
	100%	Low	25.36	20.39	4.97	≤13
		Mid	25.71	21.19	4.52	≤13
		High	25.81	21.13	4.68	≤13
20	1	Low	25.96	21.05	4.91	≤13
		Mid	26.44	21.59	4.85	≤13
		High	26.77	21.89	4.88	≤13
	50%	Low	25.55	20.65	4.90	≤13
		Mid	25.81	21.20	4.61	≤13
		High	26.09	21.59	4.50	≤13
	100%	Low	25.18	20.68	4.50	≤13
		Mid	25.21	21.27	3.94	≤13
		High	25.43	21.49	3.94	≤13

www.tuv.com

FDD Band 4, Modulation- QPSK						
Channel Bandwidth (MHz)	Resource Block Allocation	Channel	Peak Output Power (dBm)	Average Output Power (dBm)	PAPR (dB)	PAPR Limit (dB)
5	1	Low	26.73	20.77	5.96	≤13
		Mid	26.34	20.88	5.46	≤13
		High	26.84	20.77	6.07	≤13
	50%	Low	26.22	20.26	5.96	≤13
		Mid	26.42	21.01	5.41	≤13
		High	26.69	20.29	6.40	≤13
	100%	Low	25.88	20.38	5.50	≤13
		Mid	26.08	20.96	5.12	≤13
		High	26.35	20.36	5.99	≤13
10	1	Low	26.6	20.84	5.76	≤13
		Mid	26.47	20.63	5.84	≤13
		High	26.53	20.34	6.19	≤13
	50%	Low	26.26	20.20	6.06	≤13
		Mid	26.53	20.95	5.58	≤13
		High	26.71	20.63	6.08	≤13
	100%	Low	26.26	20.25	6.01	≤13
		Mid	26.36	20.94	5.42	≤13
		High	26.65	20.92	5.73	≤13
15	1	Low	26.92	20.90	6.02	≤13
		Mid	26.88	21.47	5.41	≤13
		High	27.04	21.49	5.55	≤13
	50%	Low	26.28	21.19	5.09	≤13
		Mid	26.59	21.34	5.25	≤13
		High	26.67	21.67	5.00	≤13
	100%	Low	25.25	21.37	3.88	≤13
		Mid	25.28	21.84	3.44	≤13
		High	25.28	21.52	3.76	≤13
20	1	Low	26.68	19.80	6.88	≤13
		Mid	26.59	20.25	6.34	≤13
		High	26.5	20.22	6.28	≤13
	50%	Low	26.16	20.19	5.97	≤13
		Mid	25.9	20.98	4.92	≤13
		High	25.97	20.60	5.37	≤13
	100%	Low	25.64	20.30	5.34	≤13
		Mid	25.56	20.81	4.75	≤13
		High	25.83	20.48	5.35	≤13

FDD Band 5, Modulation- QPSK						
Channel Bandwidth (MHz)	Resource Block Allocation	Channel	Peak Output Power (dBm)	Average Output Power (dBm)	PAPR (dB)	PAPR Limit (dB)
5	1	Low	25.86	21.46	4.40	≤13
		Mid	24.8	21.44	3.36	≤13
		High	25.99	21.60	4.39	≤13
	50%	Low	25.69	21.19	4.50	≤13
		Mid	25.19	21.40	3.79	≤13
		High	25.73	21.19	4.54	≤13
	100%	Low	25.47	21.13	4.34	≤13
		Mid	25.74	21.33	4.41	≤13
		High	25.35	21.14	4.21	≤13
10	1	Low	25.73	21.56	4.17	≤13
		Mid	24.32	21.36	2.96	≤13
		High	26.3	21.62	4.68	≤13
	50%	Low	25.71	21.23	4.48	≤13
		Mid	24.98	21.35	3.63	≤13
		High	26.67	21.18	5.49	≤13
	100%	Low	25.74	21.33	4.41	≤13
		Mid	26.1	21.34	4.76	≤13
		High	25.77	21.24	4.53	≤13

FDD Band 17, Modulation- QPSK						
Channel Bandwidth (MHz)	Resource Block Allocation	Channel	Peak Output Power (dBm)	Average Output Power (dBm)	PAPR (dB)	PAPR Limit (dB)
5	1	Low	26.32	22.25	4.18	≤13
		Mid	25.82	22.10	3.72	≤13
		High	26.33	22.16	4.17	≤13
	50%	Low	25.87	21.54	4.33	≤13
		Mid	25.81	21.56	4.25	≤13
		High	26.14	21.43	4.71	≤13
	100%	Low	25.50	21.53	3.97	≤13
		Mid	25.50	21.75	3.75	≤13

www.tuv.com

		High	25.96	21.43	4.53	≤13
10	1	Low	26.48	21.29	5.19	≤13
		Mid	26.61	21.40	5.21	≤13
		High	25.74	21.21	4.53	≤13
	50%	Low	25.83	21.70	4.13	≤13
		Mid	25.71	21.58	4.13	≤13
		High	25.63	21.68	3.95	≤13
	100%	Low	25.80	21.71	4.09	≤13
		Mid	25.84	21.65	4.19	≤13
		High	25.83	21.55	4.28	≤13

FDD Band 13, Modulation- QPSK						
Channel Bandwidth (MHz)	Resource Block Allocation	Channel	Peak Output Power (dBm)	Average Output Power (dBm)	PAPR (dB)	PAPR Limit (dB)
10	1	Mid	25.81	21.87	3.94	≤13
	50%	Mid	25.94	21.99	3.95	≤13
	100%	Mid	25.91	21.91	4.00	≤13

FDD Band 2, Modulation- 16-QAM						
Channel Bandwidth (MHz)	Resource Block Allocation	Channel	Peak Output Power (dBm)	Average Output Power (dBm)	PAPR (dB)	PAPR Limit (dB)
5	1	Low	25.8	20.45	5.35	≤13
		Mid	26.3	20.74	5.56	≤13
		High	26.44	20.85	5.59	≤13
	50%	Low	25.68	19.45	6.23	≤13
		Mid	26.01	20.41	5.60	≤13
		High	26.09	20.24	5.85	≤13
	100%	Low	25.49	19.77	5.72	≤13
		Mid	25.75	20.36	5.39	≤13
		High	25.84	20.26	5.58	≤13
10	1	Low	26.31	19.13	7.18	≤13
		Mid	26.51	19.87	6.64	≤13
		High	26.73	20.71	6.02	≤13
	50%	Low	25.84	19.90	5.94	≤13
		Mid	26.37	20.31	6.06	≤13
		High	26.37	20.46	5.91	≤13
	100%	Low	25.96	19.55	6.41	≤13
		Mid	26.13	20.33	5.80	≤13
		High	26.18	20.33	5.85	≤13
15	1	Low	26.91	19.97	6.94	≤13

www.tuv.com

	50%	Mid	26.81	20.93	5.88	≤13
		High	26.7	21.19	5.51	≤13
		Low	25.83	19.75	6.08	≤13
		Mid	25.97	20.46	5.51	≤13
		High	26.43	20.50	5.93	≤13
		Low	24.41	19.61	4.80	≤13
	100%	Mid	25.08	20.34	4.74	≤13
		High	25.34	20.43	4.91	≤13
		Low	26.78	20.52	6.26	≤13
20	1	Mid	27.14	20.37	6.77	≤13
		High	27.24	21.23	6.01	≤13
		Low	25.44	19.99	5.45	≤13
	50%	Mid	25.62	20.36	5.26	≤13
		High	26.19	20.61	5.58	≤13
		Low	24.41	19.84	4.57	≤13
	100%	Mid	24.8	20.43	4.37	≤13
		High	25.34	20.38	4.96	≤13

FDD Band 4, Modulation- 16-QAM						
Channel Bandwidth (MHz)	Resource Block Allocation	Channel	Peak Output Power (dBm)	Average Output Power (dBm)	PAPR (dB)	PAPR Limit (dB)
5	1	Low	26.54	20.61	5.93	≤13
		Mid	26.54	21.81	4.73	≤13
		High	26.5	21.08	5.42	≤13
	50%	Low	26.47	20.25	6.22	≤13
		Mid	26.23	20.97	5.26	≤13
		High	26.62	20.50	6.12	≤13
	100%	Low	26.3	20.43	5.87	≤13
		Mid	25.99	21.12	4.87	≤13
		High	25.73	20.57	5.16	≤13
10	1	Low	26.52	21.31	5.21	≤13
		Mid	26.73	21.89	4.84	≤13
		High	27.63	21.73	5.90	≤13
	50%	Low	26.4	20.41	5.99	≤13
		Mid	26.52	20.92	5.60	≤13
		High	26.77	20.67	6.10	≤13
	100%	Low	26.52	19.44	7.08	≤13
		Mid	26.46	21.02	5.44	≤13
		High	26.8	20.55	6.25	≤13
15	1	Low	26.75	19.75	7.00	≤13
		Mid	26.76	20.37	6.39	≤13
		High	27.12	20.81	6.31	≤13
	50%	Low	26.18	20.19	5.99	≤13

www.tuv.com

	100%	Mid	26.68	20.77	5.91	≤13
		High	26.7	20.46	6.24	≤13
		Low	25.61	20.47	5.14	≤13
		Mid	25.65	20.75	4.90	≤13
		High	25.68	20.44	5.24	≤13
20	1	Low	26.79	21.22	5.57	≤13
		Mid	26.84	21.82	5.02	≤13
		High	26.75	21.52	5.23	≤13
	50%	Low	26.12	20.73	5.39	≤13
		Mid	26.12	21.12	5.00	≤13
		High	26.19	21.07	5.12	≤13
	100%	Low	24.93	20.69	4.24	≤13
		Mid	25.18	20.97	4.21	≤13
		High	25.44	20.96	4.48	≤13

FDD Band 5, Modulation- 16-QAM						
Channel Bandwidth (MHz)	Resource Block Allocation	Channel	Peak Output Power (dBm)	Average Output Power (dBm)	PAPR (dB)	PAPR Limit (dB)
5	1	Low	25.78	21.06	4.72	≤13
		Mid	25.23	20.74	4.49	≤13
		High	25.89	21.26	4.63	≤13
	50%	Low	25.57	20.18	5.39	≤13
		Mid	25.18	20.57	4.61	≤13
		High	25.62	20.40	5.22	≤13
	100%	Low	25.29	20.24	5.05	≤13
		Mid	25.52	20.79	4.73	≤13
		High	25.41	20.32	5.09	≤13
10	1	Low	25.83	20.95	4.88	≤13
		Mid	24.71	20.48	4.23	≤13
		High	26.35	21.12	5.23	≤13
	50%	Low	25.63	20.31	5.32	≤13
		Mid	25.17	20.74	4.43	≤13
		High	26.08	20.51	5.57	≤13
	100%	Low	25.71	20.43	5.28	≤13
		Mid	26.33	20.36	5.97	≤13
		High	26.03	20.36	5.67	≤13

FDD Band 17, Modulation- 16-QAM						
Channel Bandwidth (MHz)	Resource Block Allocation	Channel	Peak Output Power (dBm)	Average Output Power (dBm)	PAPR (dB)	PAPR Limit (dB)
5	1	Low	26.14	21.02	5.12	≤13
		Mid	25.56	21.48	4.08	≤13
		High	25.84	20.61	5.23	≤13
	50%	Low	25.77	20.09	5.68	≤13
		Mid	25.76	20.68	5.08	≤13
		High	26	20.45	5.55	≤13
	100%	Low	25.47	20.51	4.96	≤13
		Mid	25.67	20.47	5.2	≤13
		High	25.84	20.50	5.34	≤13
10	1	Low	26.14	20.80	5.34	≤13
		Mid	26.08	20.55	5.53	≤13
		High	25.64	19.78	6.06	≤13
	50%	Low	25.74	20.59	5.15	≤13
		Mid	25.61	20.53	5.08	≤13
		High	25.55	20.74	4.81	≤13
	100%	Low	25.85	20.66	5.19	≤13
		Mid	25.91	20.57	5.34	≤13
		High	25.84	20.67	5.17	≤13

FDD Band 13, Modulation- 16-QAM						
Channel Bandwidth (MHz)	Resource Block Allocation	Channel	Peak Output Power (dBm)	Average Output Power (dBm)	PAPR (dB)	PAPR Limit (dB)
10	1	Mid	25.86	20.78	5.08	≤13
	50%	Mid	25.69	20.90	4.79	≤13
	100%	Mid	25.85	20.85	5.00	≤13

www.tuv.com

**99% Occupied Bandwidth &
26dB Emission Bandwidth
Result**

Pass

Specification	FCC Part 2.1049 & RSS-Gen Issue 4 section 6.6
Measurement Bandwidth (RBW)	≥ 100KHz (1 to 5% of anticipated OBW)
Detector Function	Peak
Requirement	Reporting Only.

Test Setup:

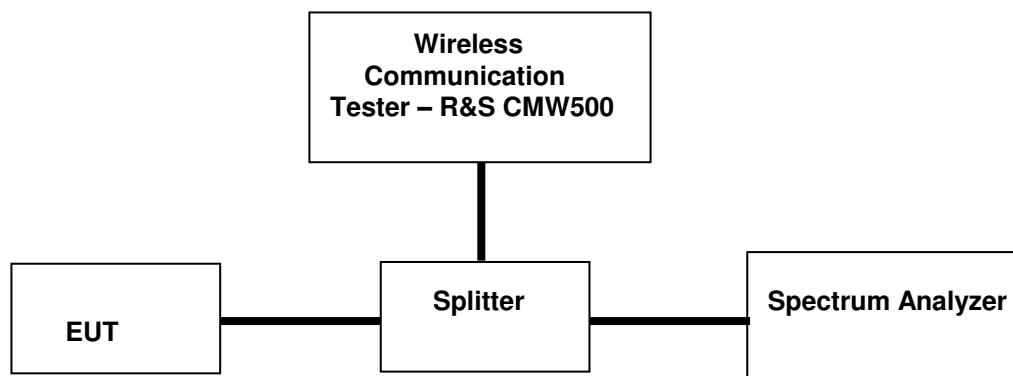

Note: For measurement of occupied bandwidth, section 4.2 in “971168 D01 Power Meas License Digital Systems v02r02” was used.

www.tuv.com

Test Results

Modulation: QPSK				
FDD Band	Bandwidth	Channel	99% Occupied Bandwidth (MHz)	-26dB Bandwidth(MHz)
2	5	Low	4.51	5.03
		Mid	4.53	5.06
		High	4.51	5.04
	10	Low	8.94	9.66
		Mid	8.93	9.66
		High	8.94	9.79
	15	Low	13.36	14.35
		Mid	13.38	14.34
		High	13.38	14.44
	20	Low	17.88	19.40
		Mid	17.84	19.25
		High	17.84	19.33
4	5	Low	4.51	5.06
		Mid	4.51	5.01
		High	4.53	5.06
	10	Low	8.94	9.75
		Mid	8.95	9.73
		High	8.94	9.75
	15	Low	13.49	15.02
		Mid	13.52	15.00
		High	13.44	14.80
	20	Low	17.88	19.35
		Mid	17.90	19.50
		High	17.87	19.37
5	5	Low	4.51	5.00
		Mid	4.52	5.05
		High	4.54	5.06
	10	Low	8.94	9.73
		Mid	8.96	9.82
		High	8.90	9.67
17	5	Low	4.52	5.05
		Mid	4.52	5.04
		High	4.51	4.99
	10	Low	8.93	9.77
		Mid	8.92	9.67
		High	8.89	9.60
13	10	Mid	8.92	9.71

www.tuv.com

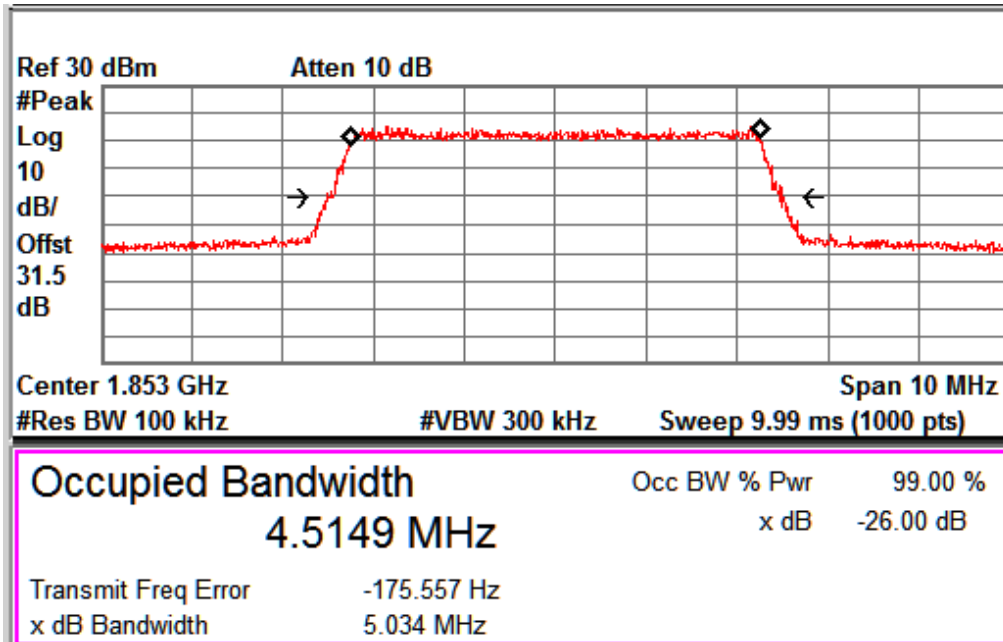

FDD Band 2_Channel Low_5MHz

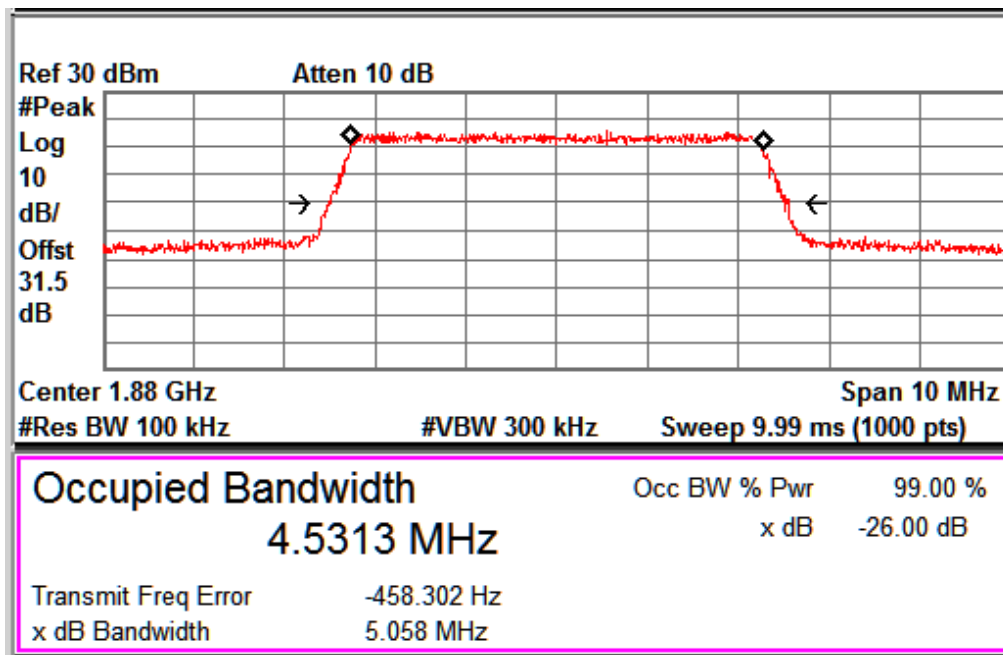

FDD Band 2_Channel Mid_5MHz

www.tuv.com

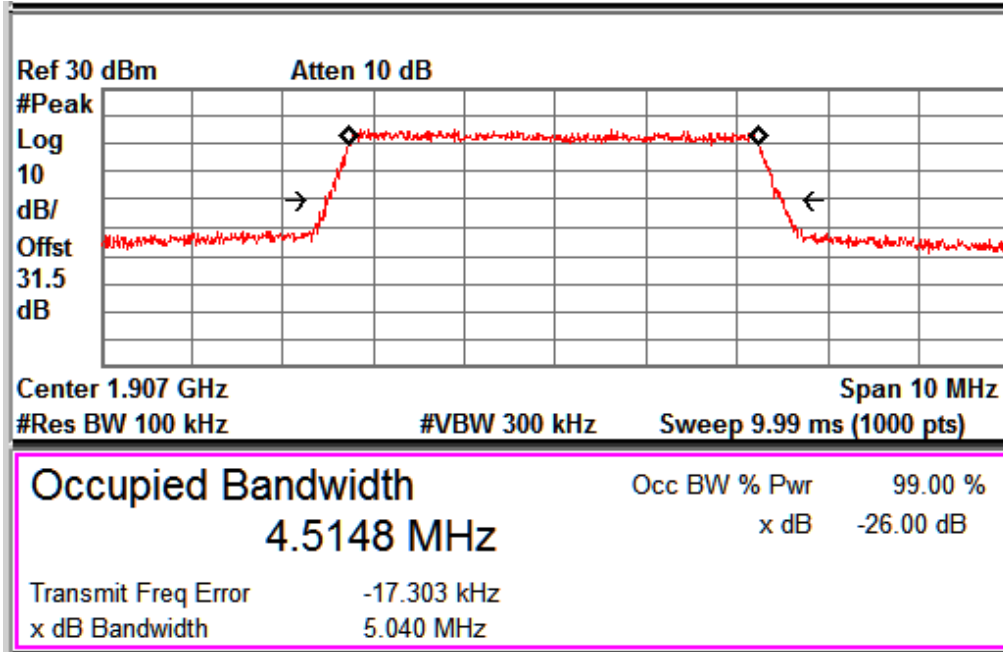

FDD Band 2_Channel High_5MHz

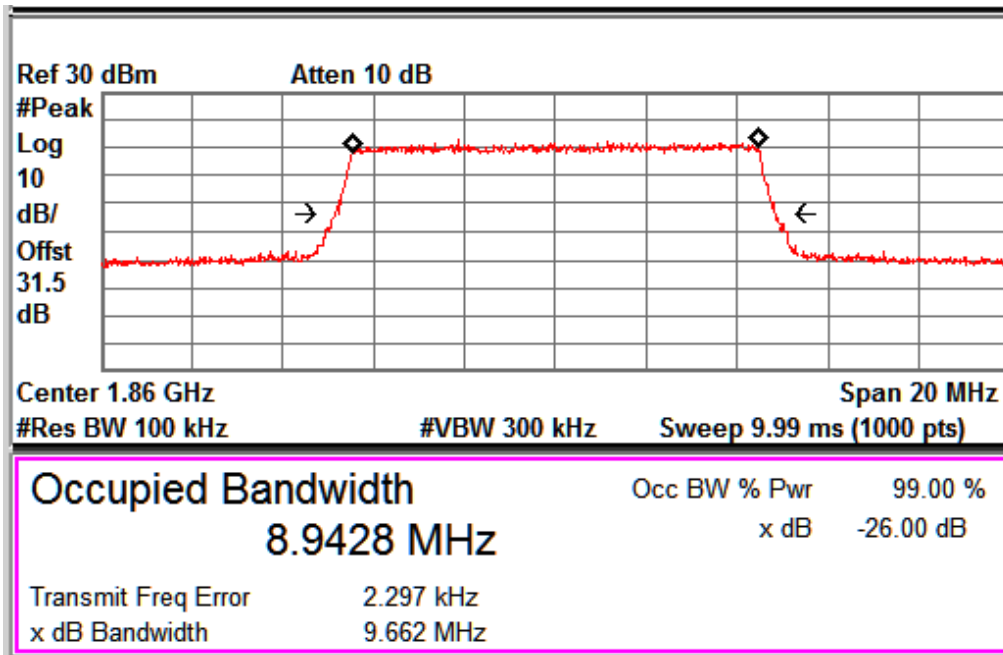

FDD Band 2_Channel Low_10MHz

www.tuv.com

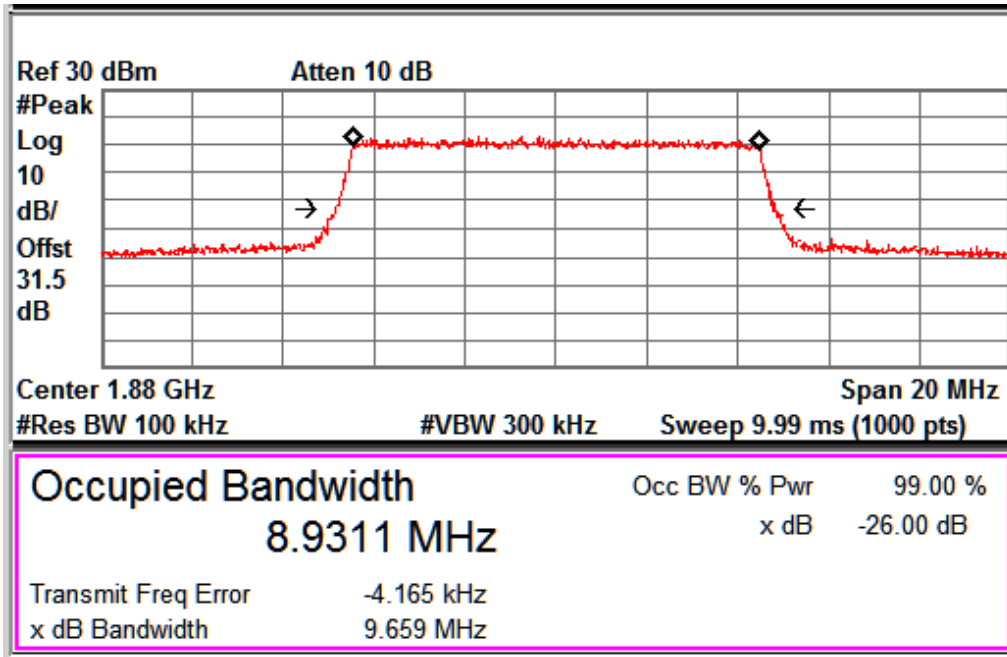

FDD Band 2_Channel Mid_10MHz

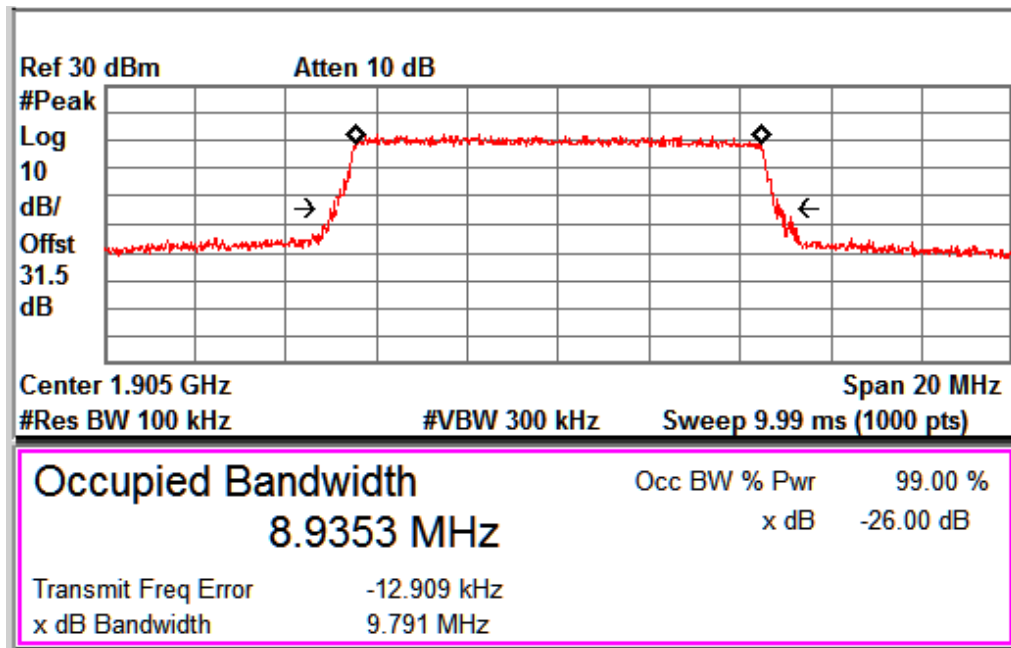

FDD Band 2_Channel High_10MHz

www.tuv.com

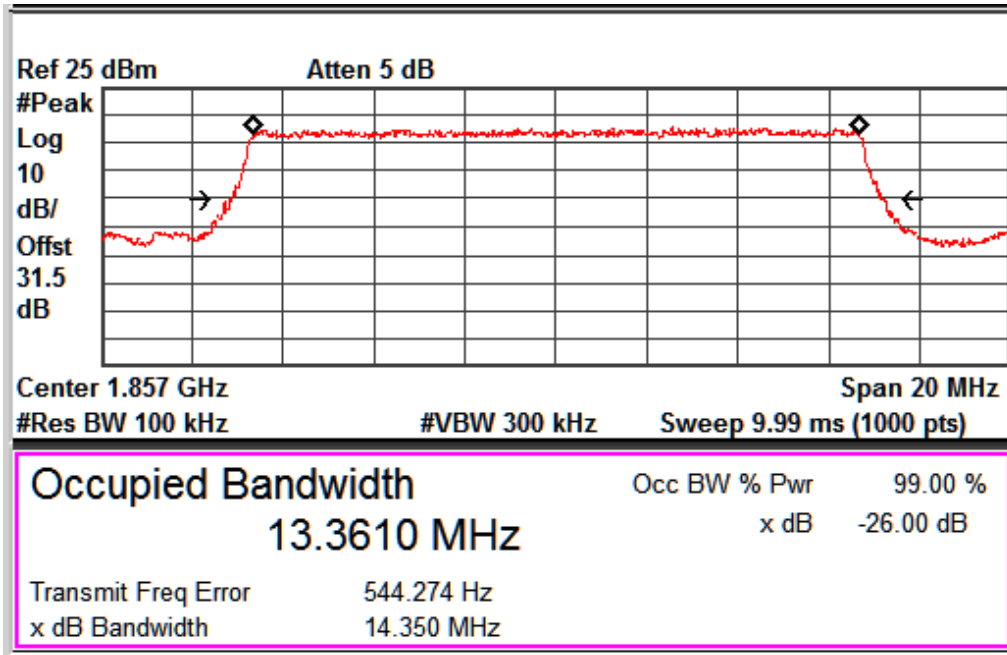

FDD Band 2_Channel Low_15MHz

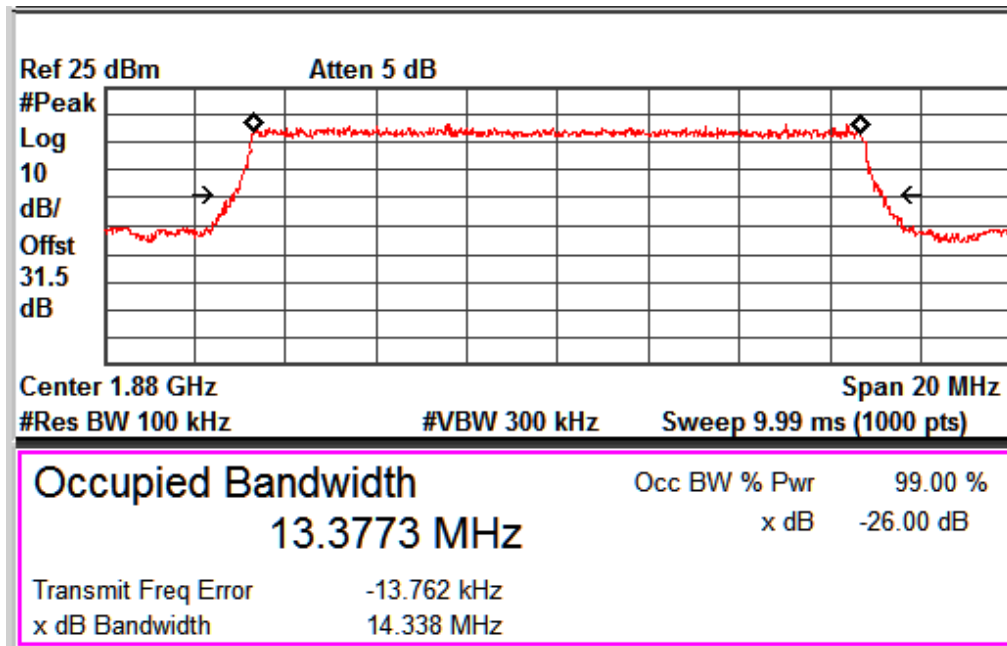

FDD Band 2_Channel Mid_15MHz

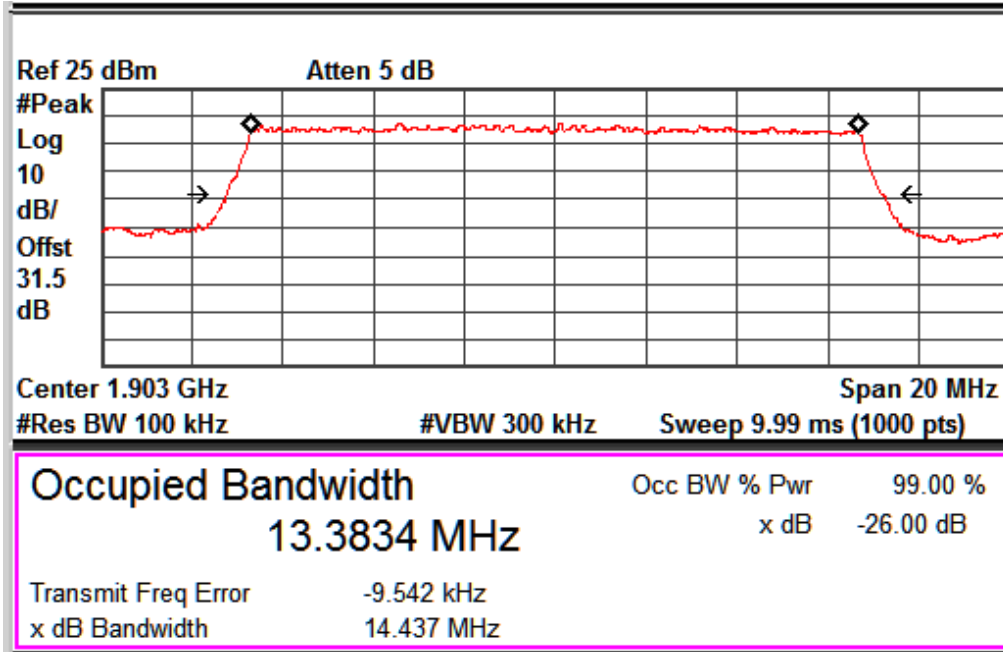

FDD Band 2_Channel High_15MHz

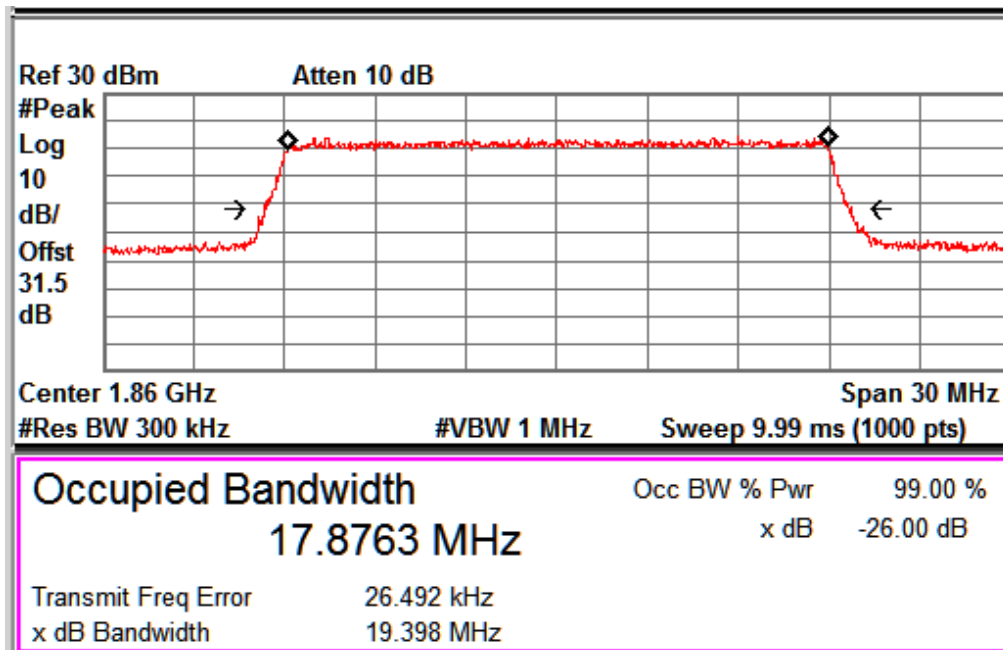

FDD Band 2_Channel Low_20MHz

www.tuv.com

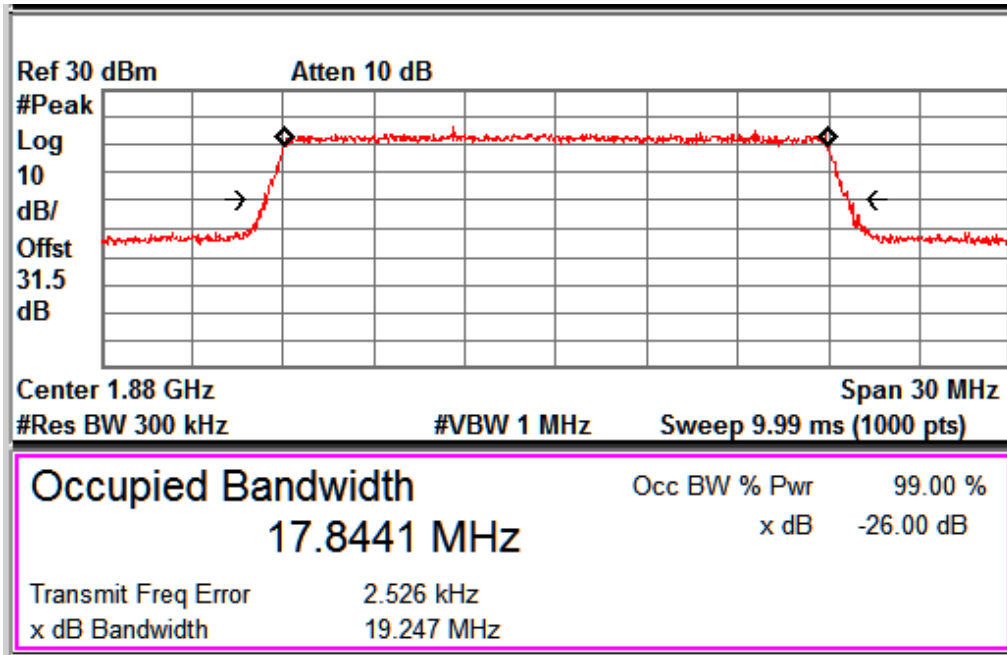

FDD Band 2_Channel Mid_20MHz

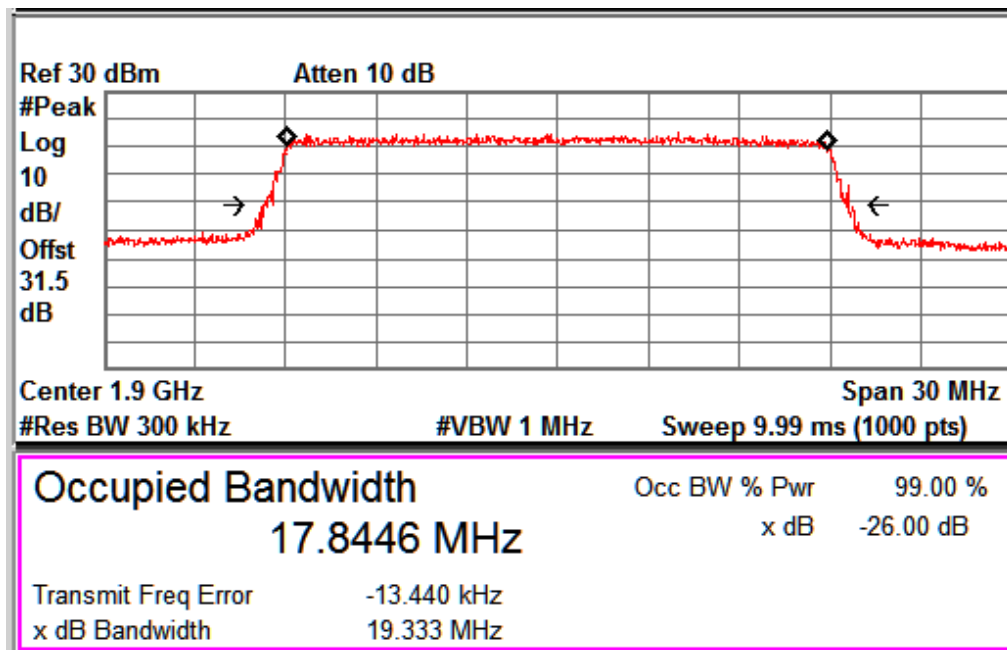

FDD Band 2_Channel High_20MHz

www.tuv.com

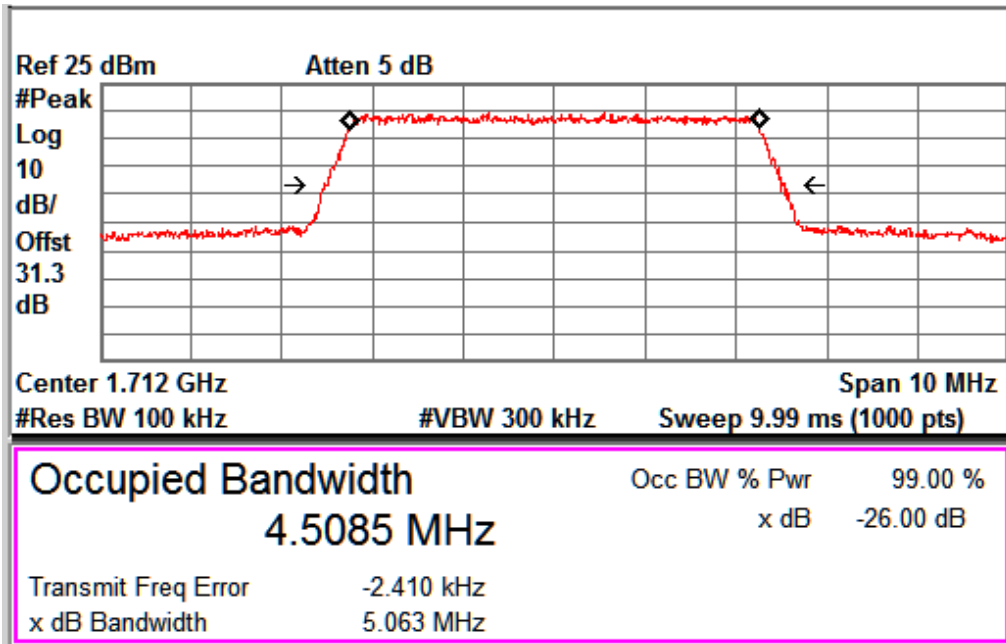

FDD Band 4_Channel Low_5MHz

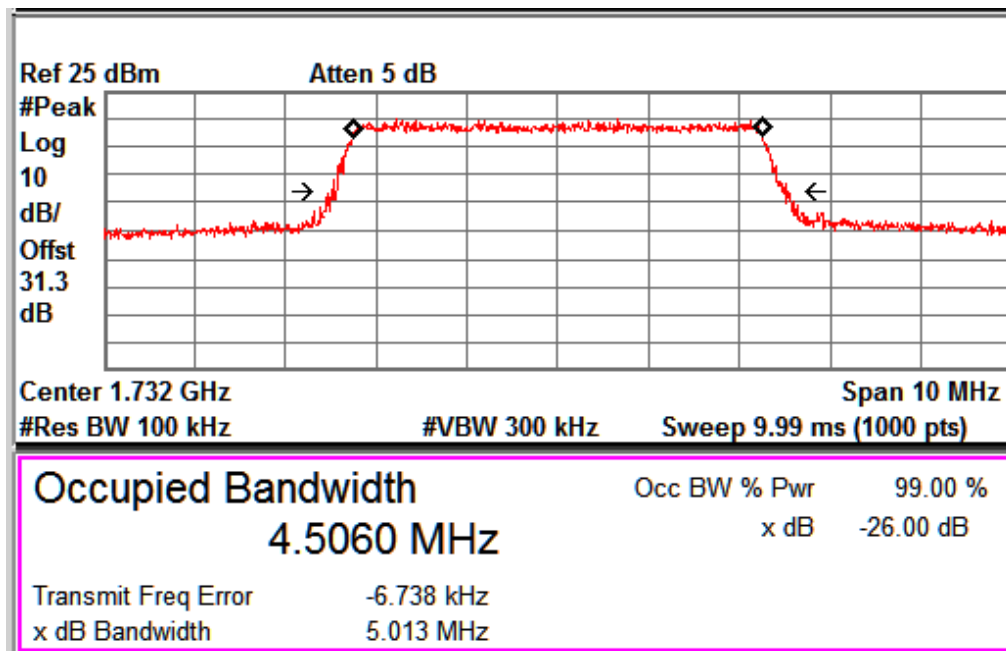

FDD Band 4_Channel Mid_5MHz

www.tuv.com

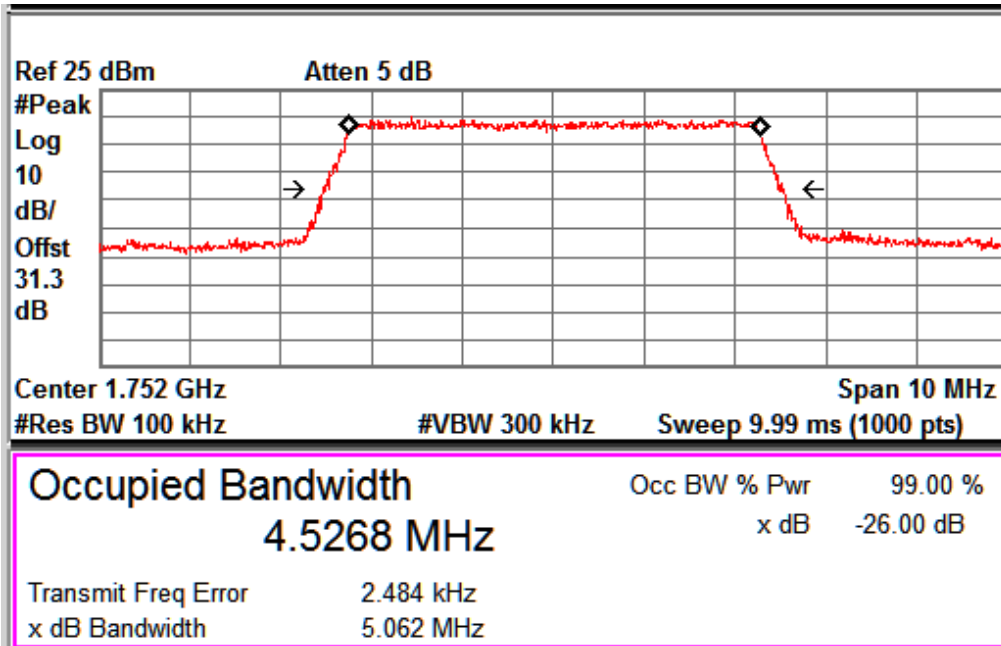

FDD Band 4_Channel High_5MHz

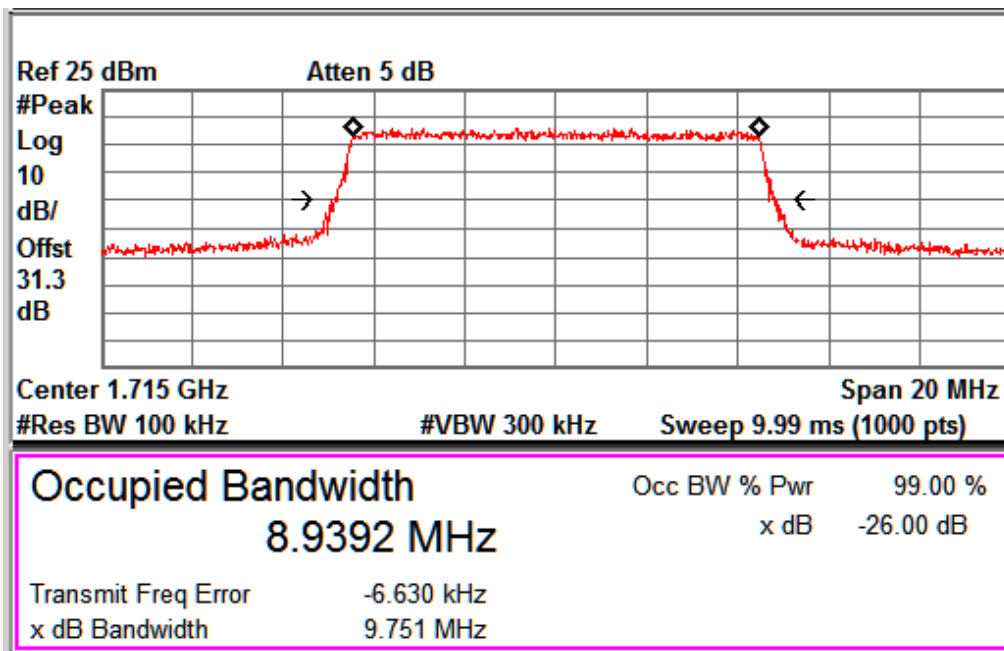

FDD Band 4_Channel Low_10MHz

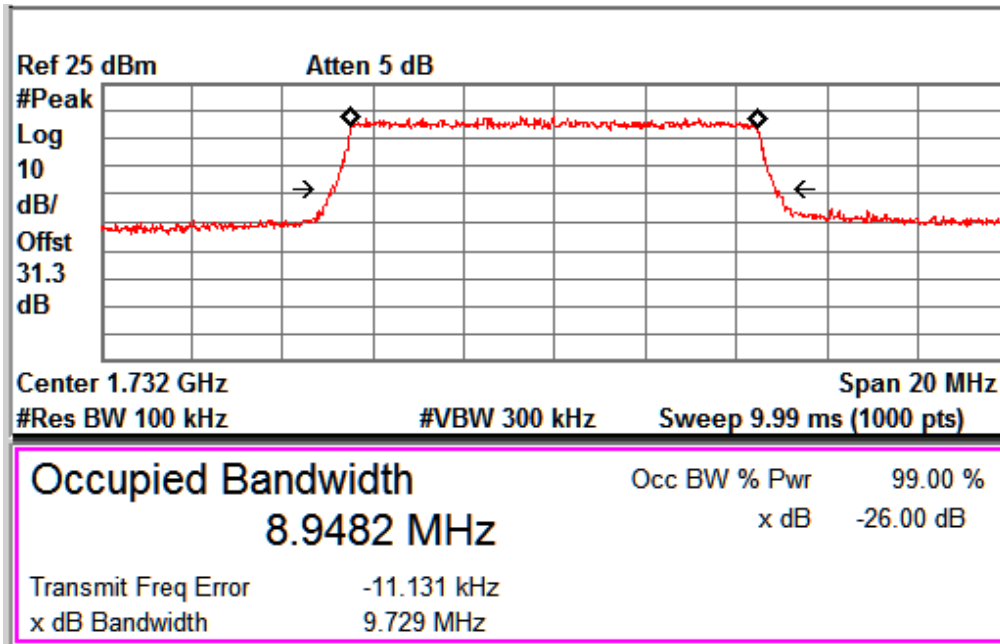
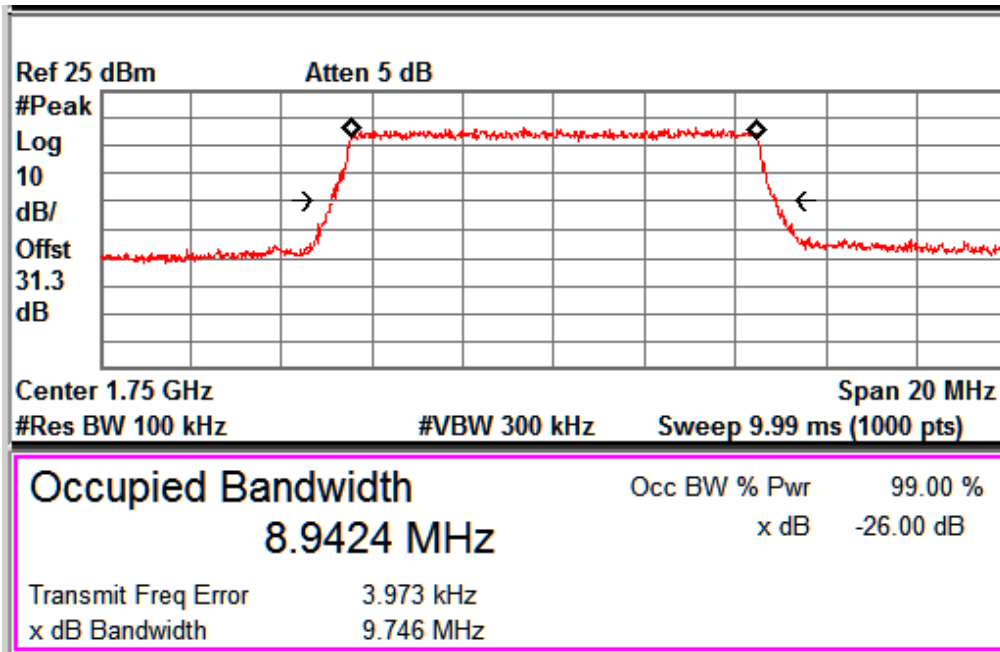
FDD Band 4_Channel Mid_10MHz

FDD Band4_Channel High_10MHz

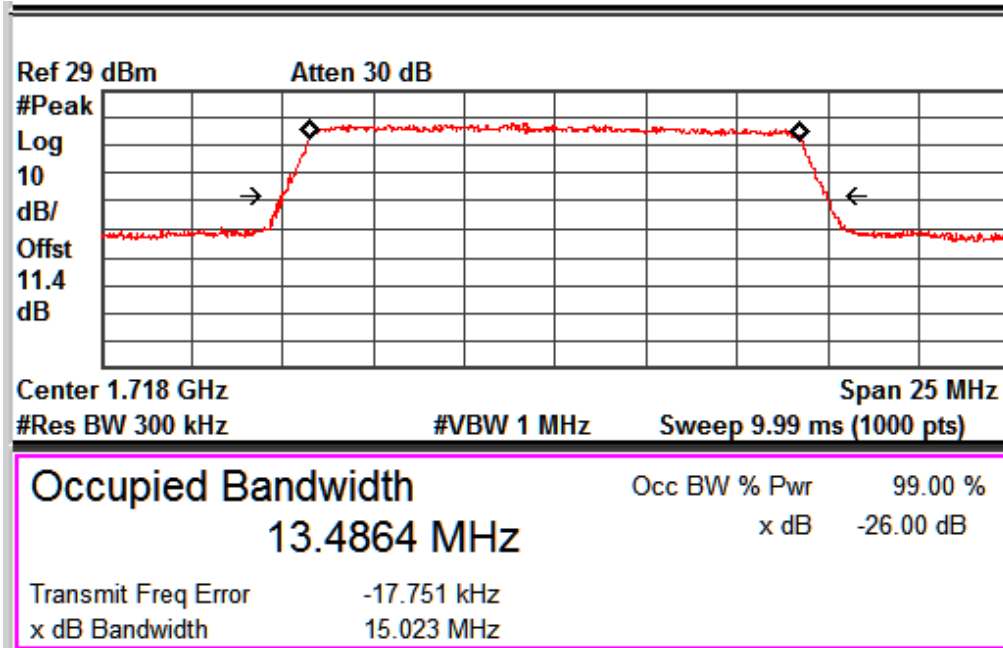
www.tuv.com

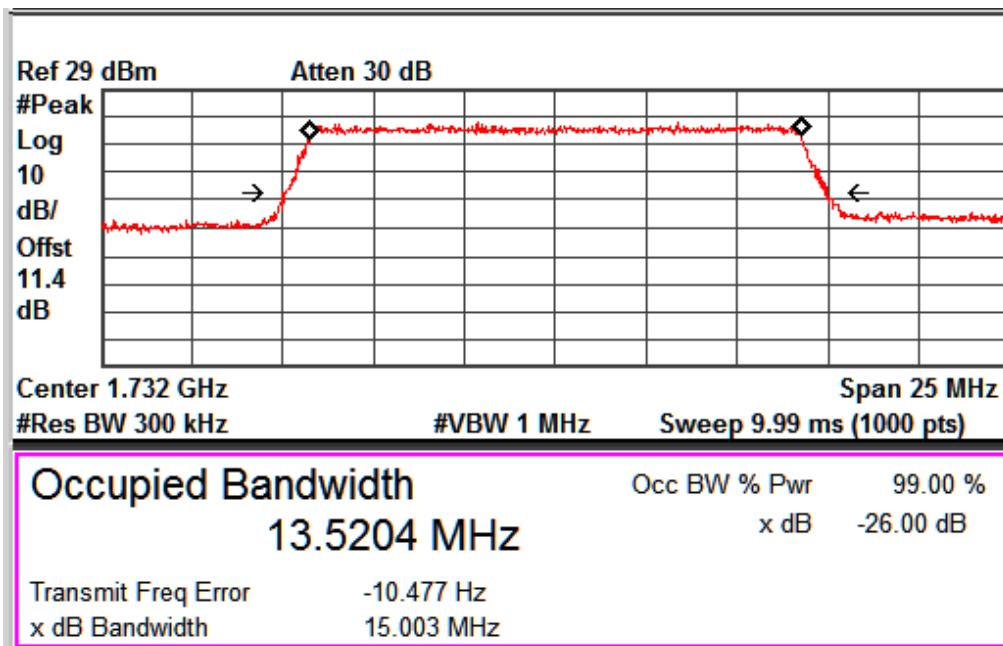

FDD Band4_Channel Low_15MHz



FDD Band4_Channel Mid_15MHz

www.tuv.com

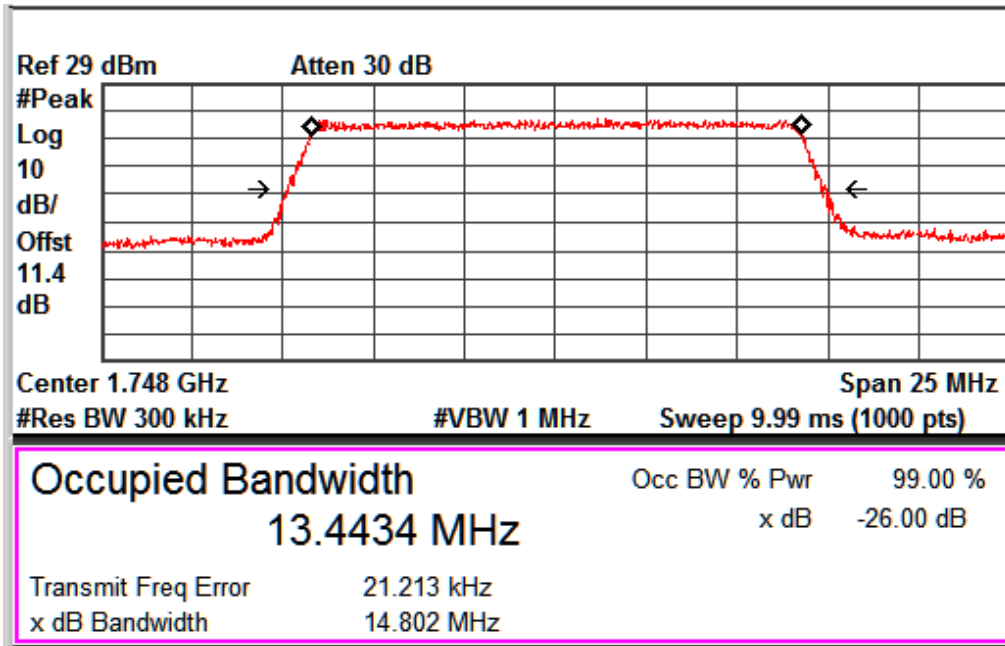

FDD Band4_Channel High_15MHz

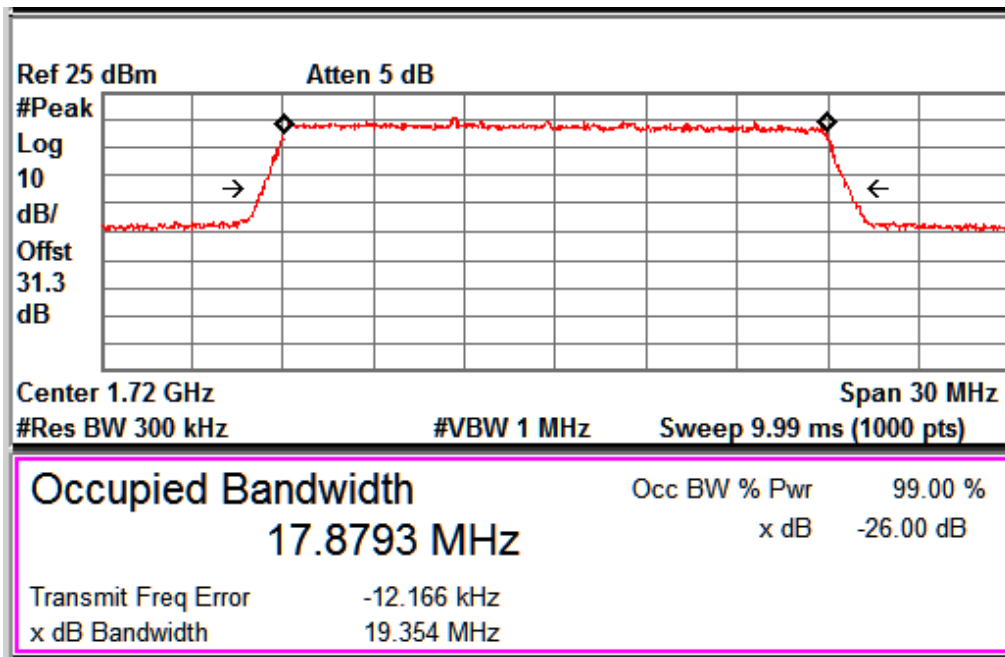

FDD Band 4_Channel Low_20MHz

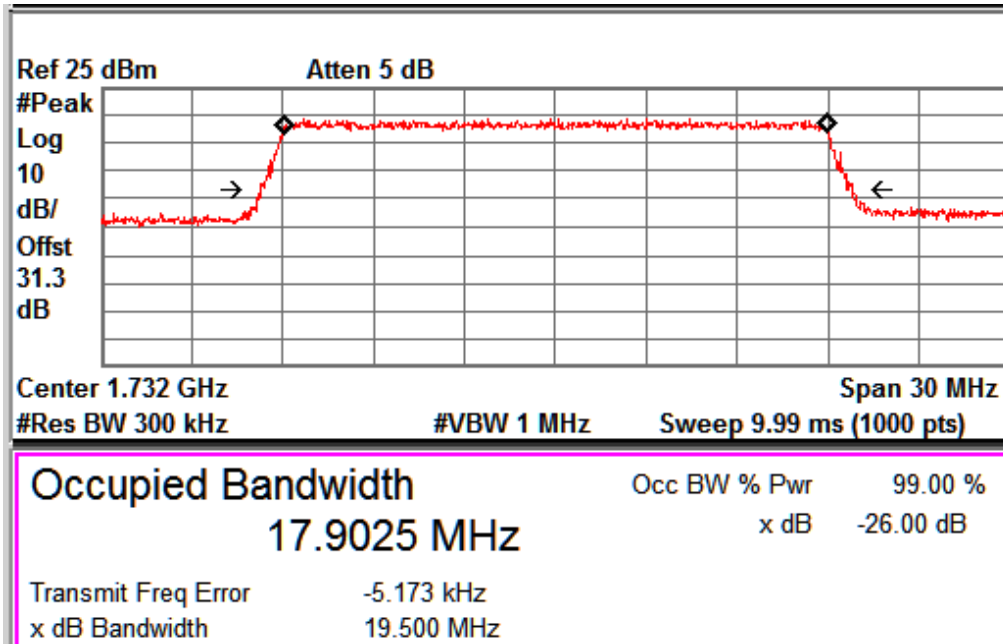
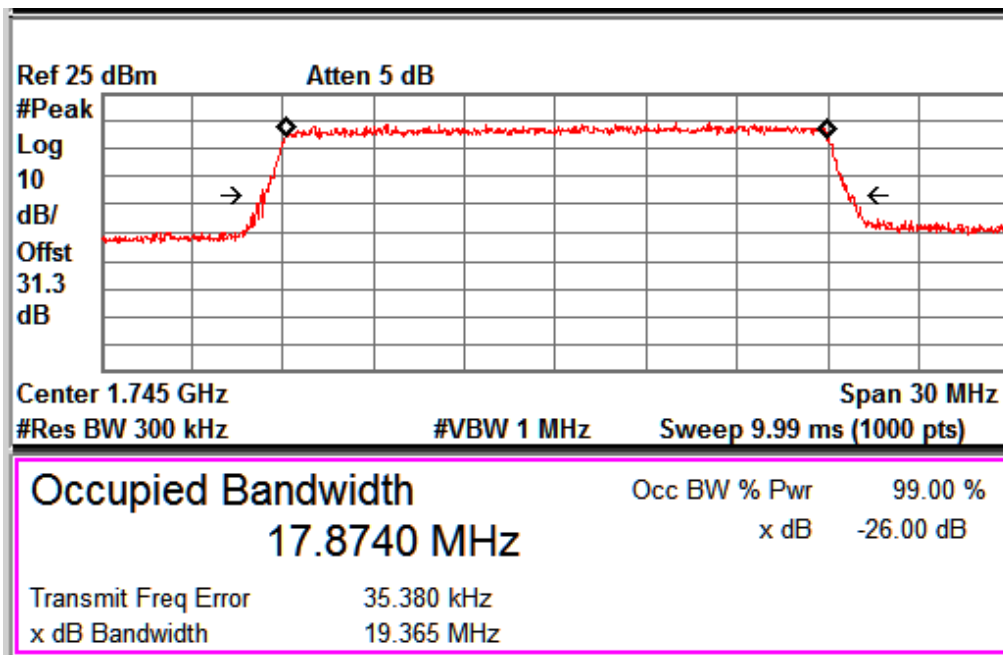
FDD Band 4_Channel Mid_20MHz

FDD Band 4_Channel High_20MHz

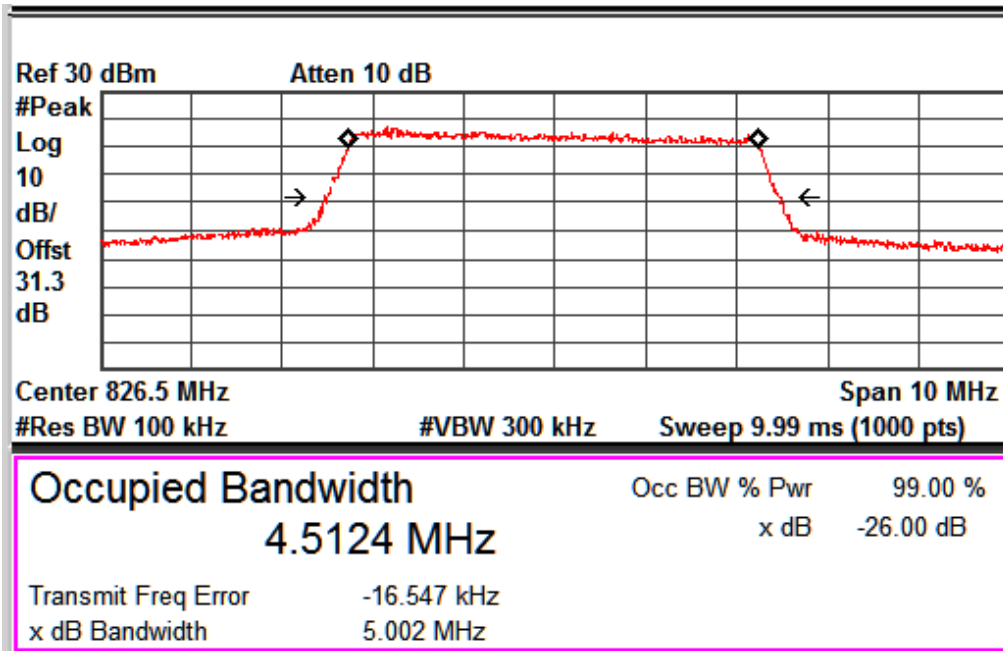
www.tuv.com

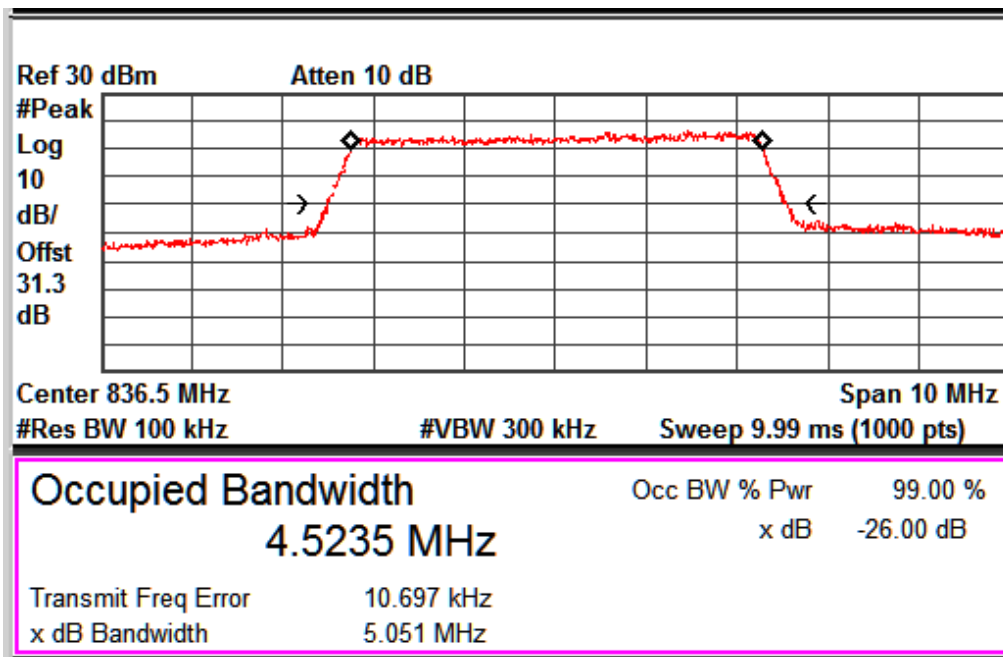

FDD Band 5_Channel Low_5MHz



FDD Band 5_Channel Mid_5MHz

www.tuv.com

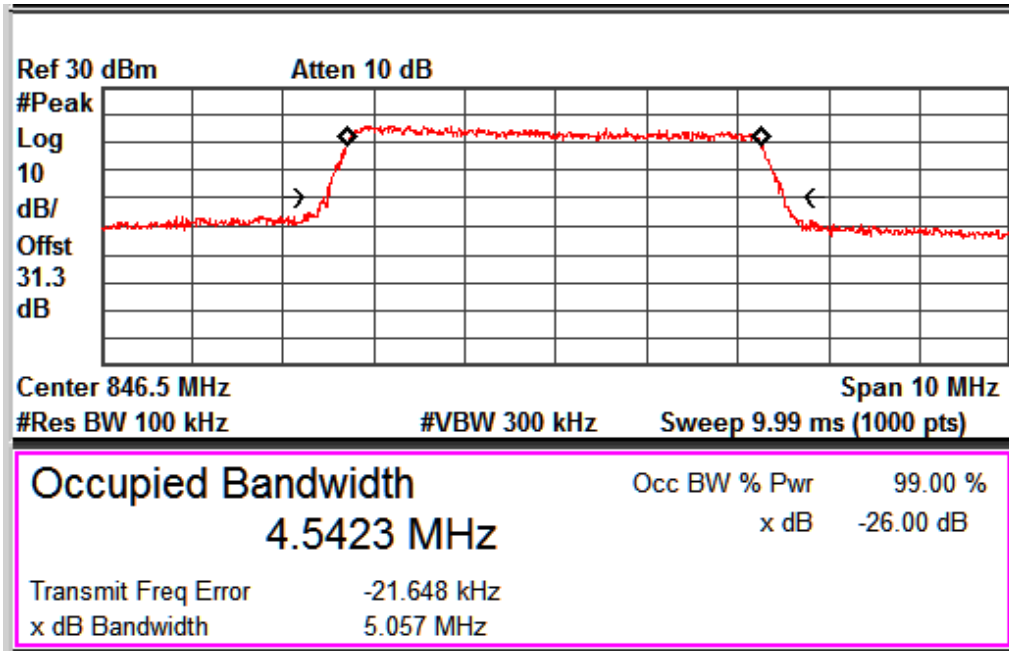

FDD Band 5_Channel High_5MHz

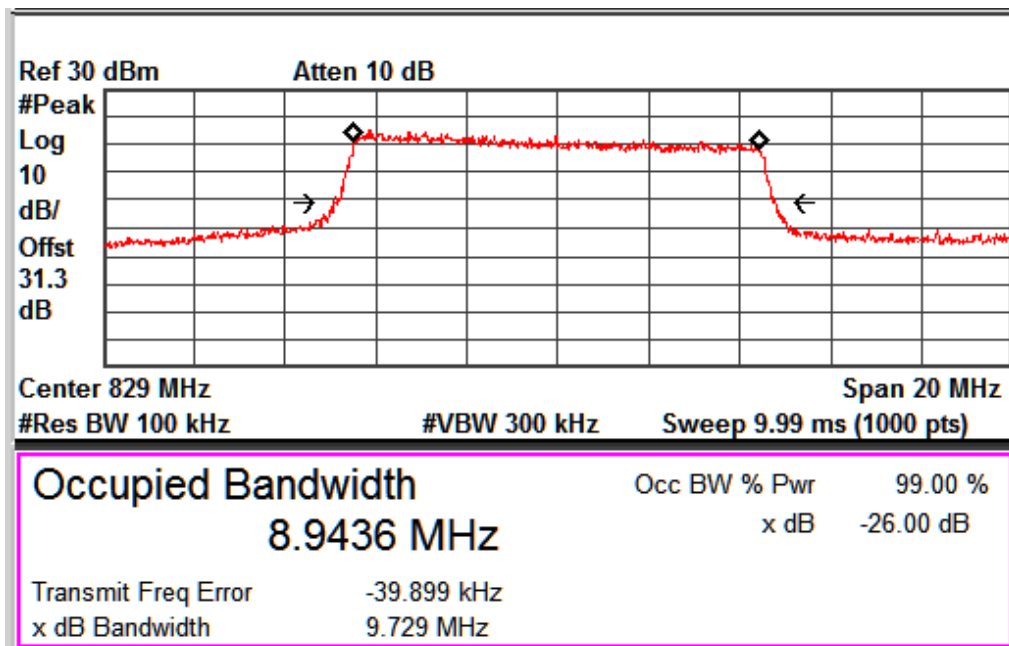

FDD Band 5_Channel Low_10MHz

www.tuv.com

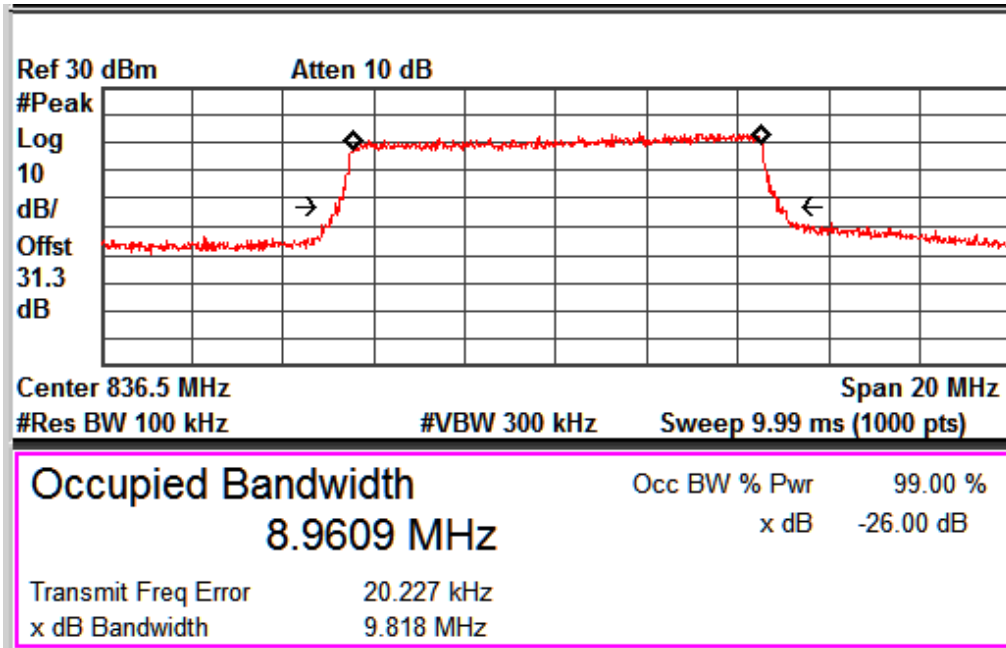

FDD Band 5_Channel Mid_10MHz

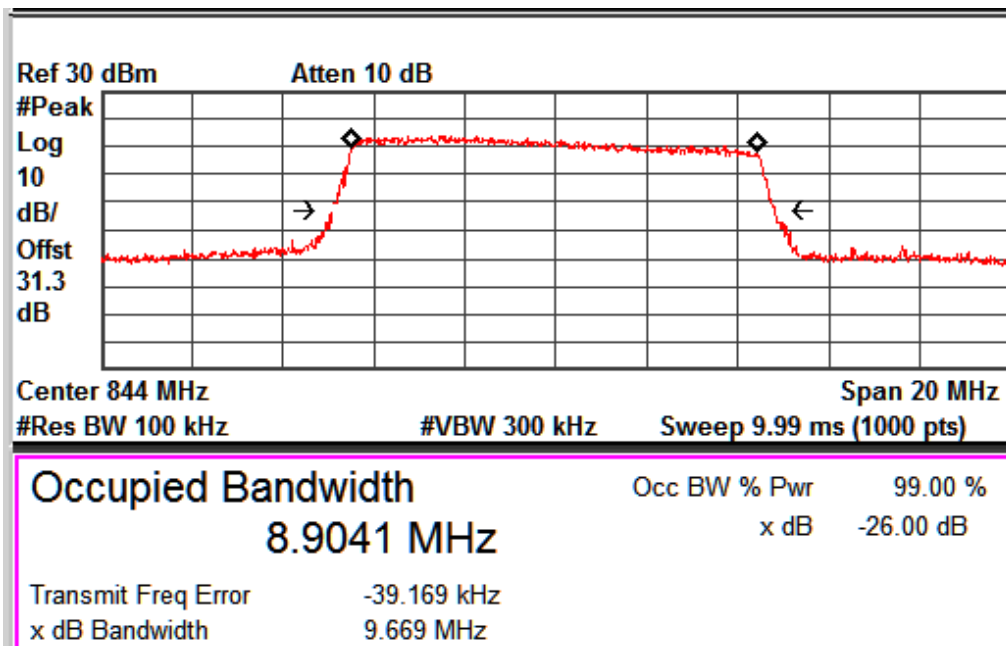

FDD Band 5_Channel High_10MHz

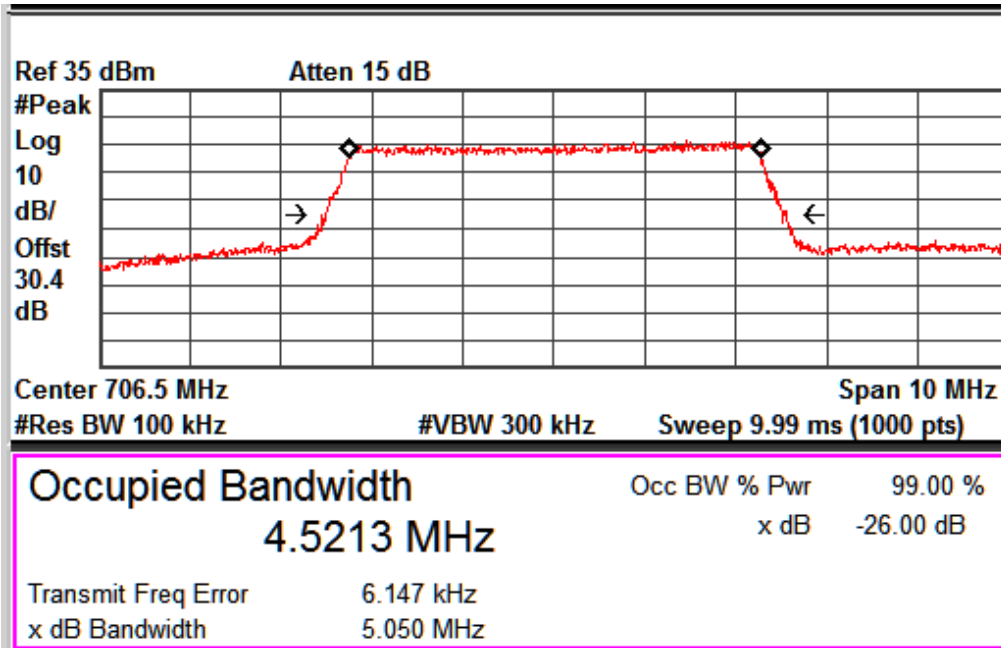

FDD Band 17_Channel Low_5MHz

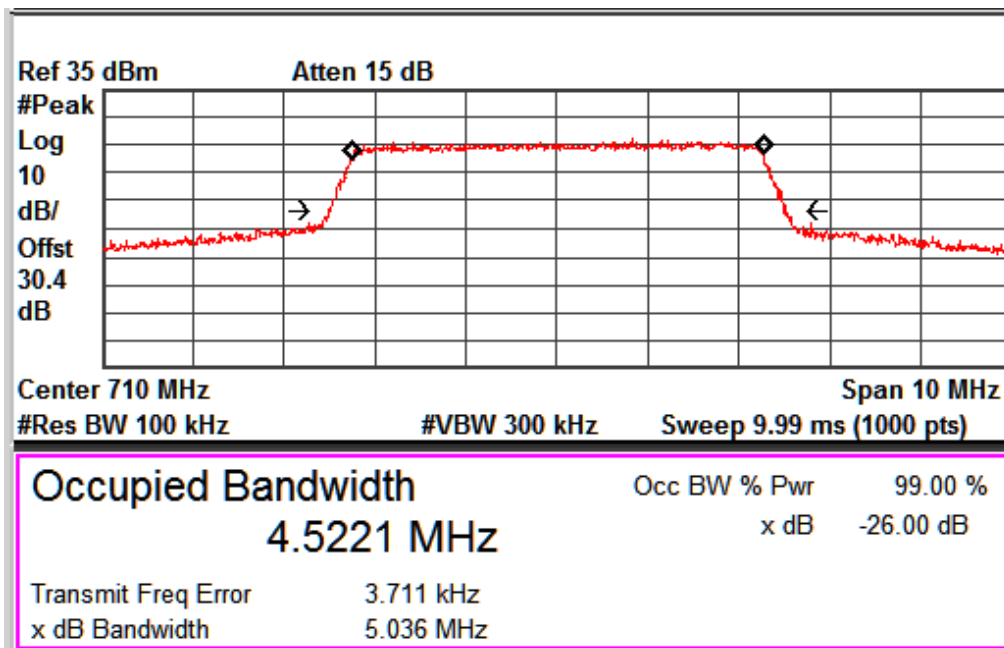

FDD Band 17_Channel Mid_5MHz

www.tuv.com

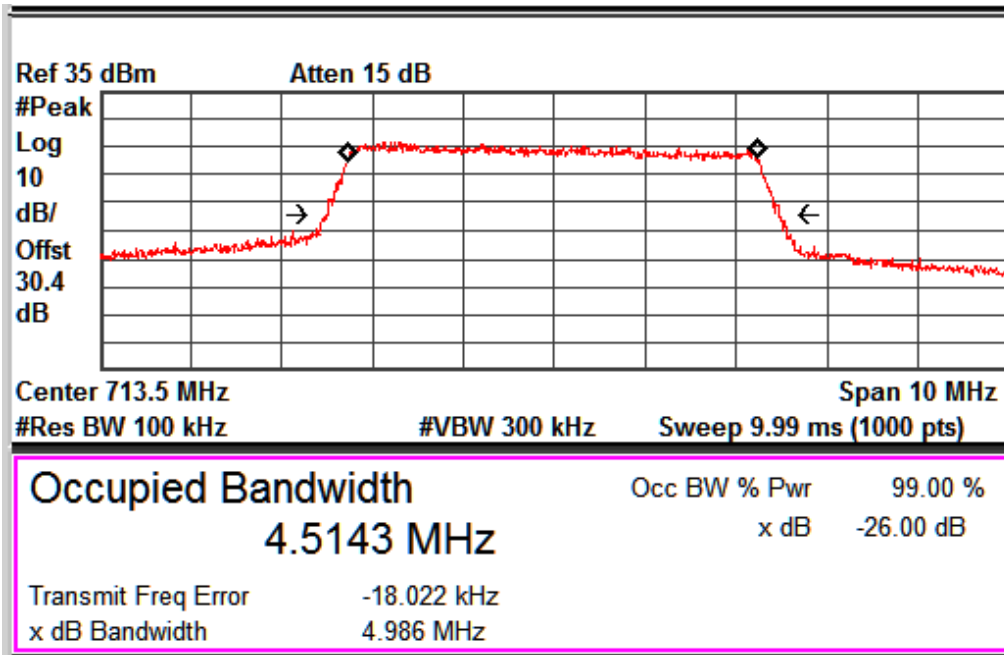

FDD Band 17_Channel High_5MHz

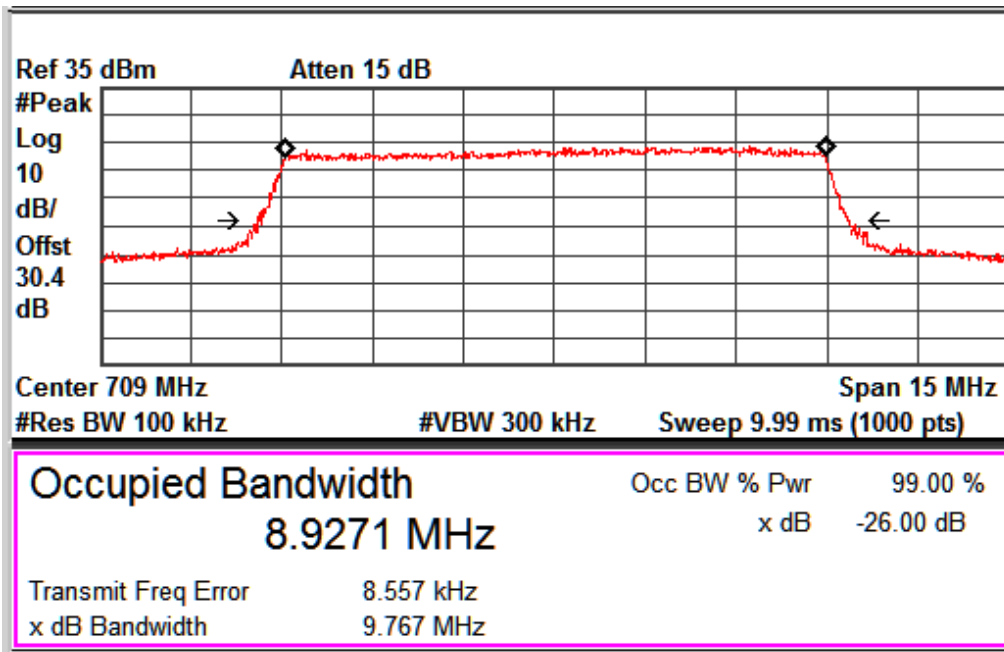

FDD Band 17_Channel Low_10MHz

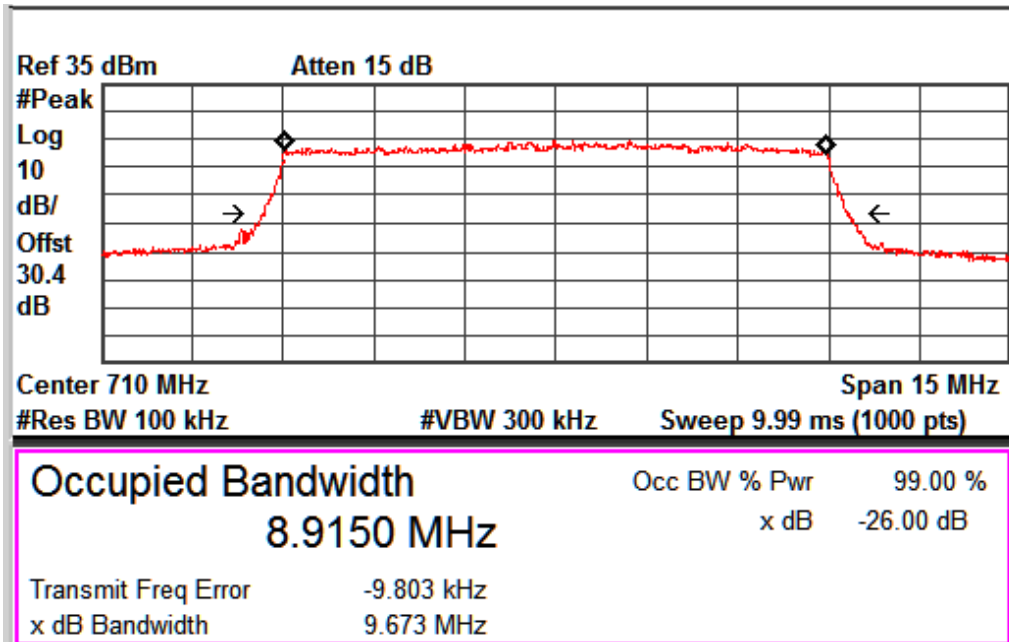
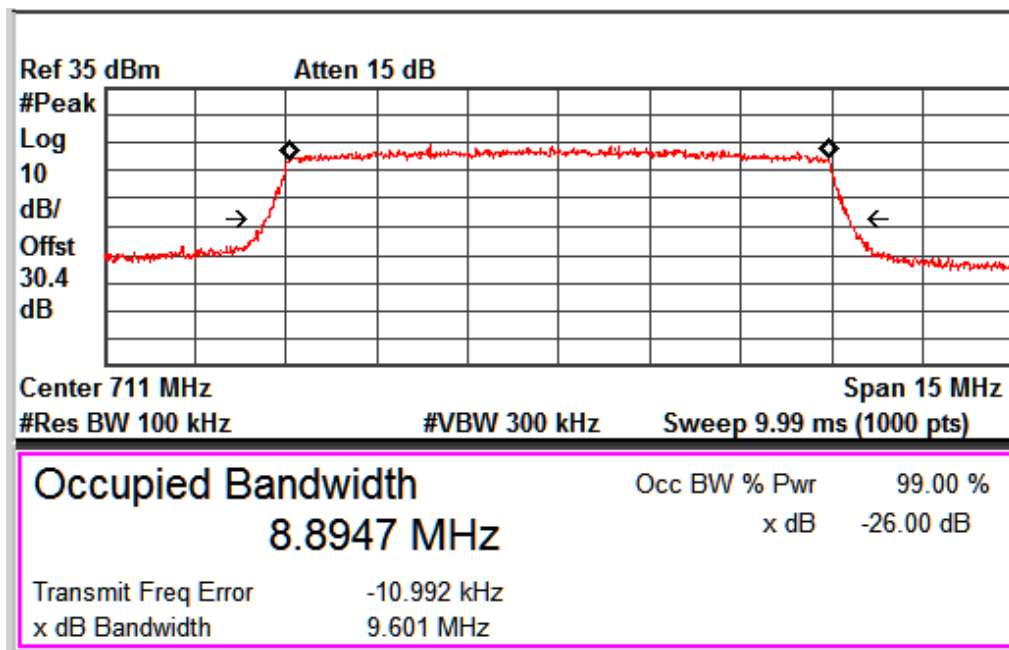
FDD Band 17_Channel Mid_10MHz

FDD Band 17_Channel High_10MHz

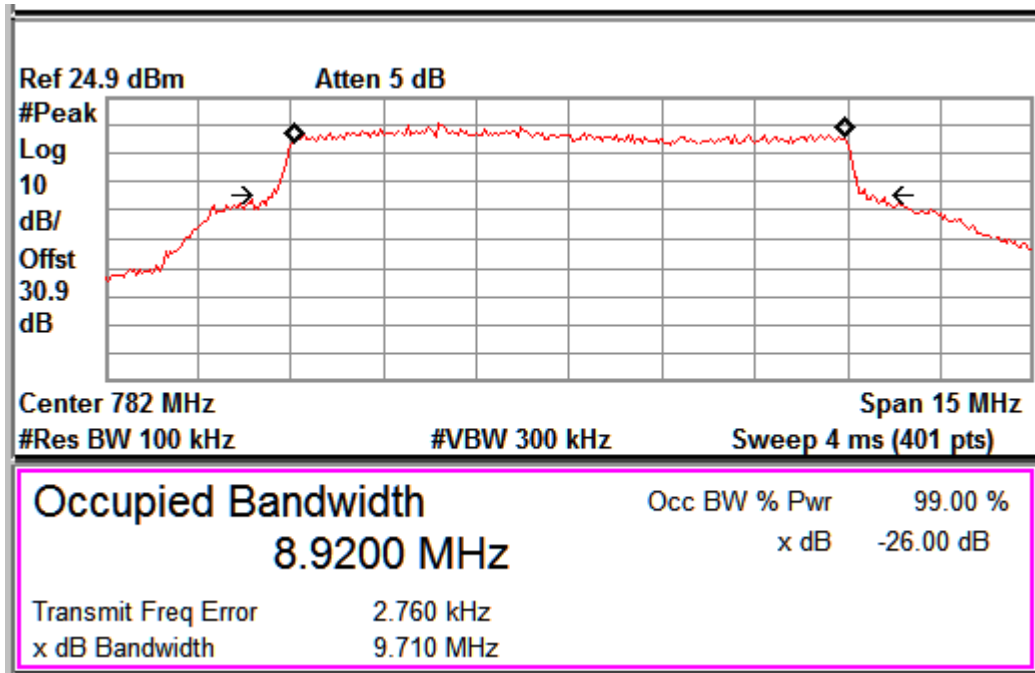
www.tuv.com



FDD Band 13_Channel Mid_10MHz

Modulation: 16QAM				
FDD Band	Bandwidth	Channel	99% Occupied Bandwidth (MHz)	-26dB Bandwidth(MHz)
2	5	Low	4.54	5.07
		Mid	4.52	5.03
		High	4.53	4.99
	10	Low	8.94	9.67
		Mid	8.94	9.75
		High	8.94	9.82
	15	Low	13.39	14.35
		Mid	13.38	14.35
		High	13.36	14.32
	20	Low	17.85	19.47
		Mid	17.88	19.25
		High	17.84	19.33
4	5	Low	4.51	5.03
		Mid	4.52	5.00
		High	4.51	4.99
	10	Low	8.93	9.54
		Mid	8.95	9.82
		High	8.94	9.65
	15	Low	13.47	14.96
		Mid	13.50	14.93
		High	13.44	14.84
	20	Low	17.91	19.59
		Mid	17.90	19.48
		High	17.86	19.31
5	5	Low	4.51	5.00
		Mid	4.53	5.01
		High	4.51	4.99
	10	Low	8.94	9.60
		Mid	8.94	9.63
		High	8.88	9.46
17	5	Low	4.54	5.07
		Mid	4.51	5.05
		High	4.53	5.05
	10	Low	8.91	9.61
		Mid	8.90	9.59
		High	8.90	9.57
13	10	Mid	8.91	9.76

www.tuv.com

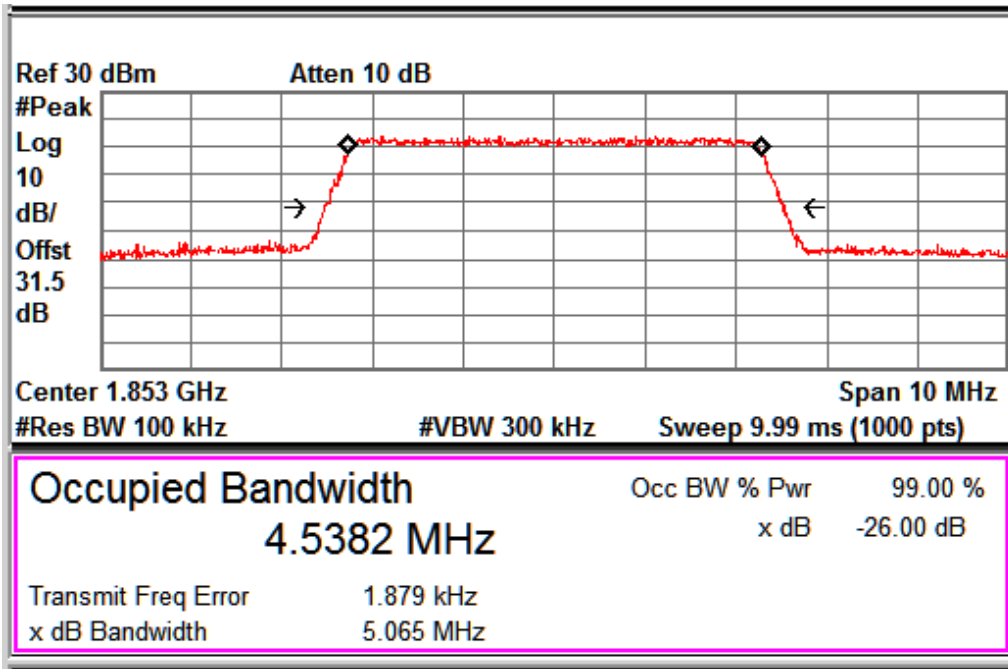

FDD Band 2_Channel Low_5MHz

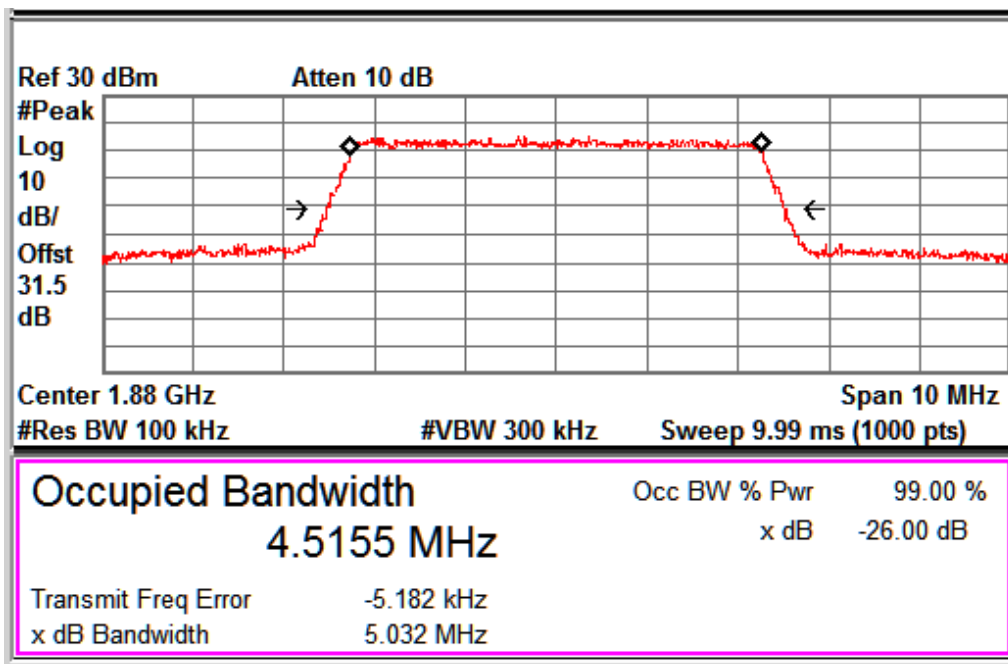

FDD Band 2_Channel Mid_5MHz

www.tuv.com

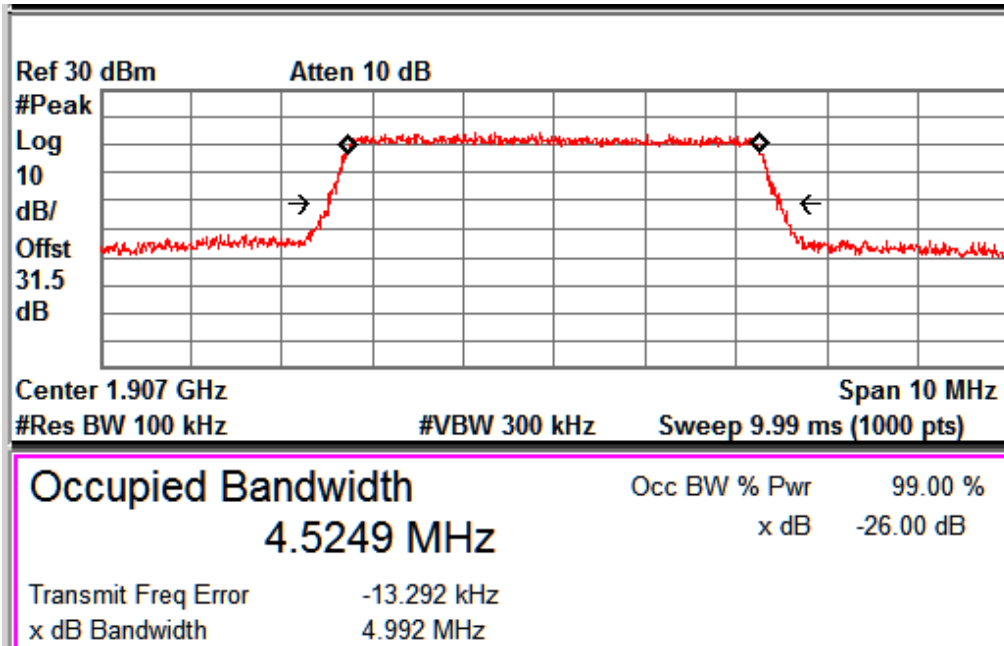

FDD Band 2_Channel High_5MHz

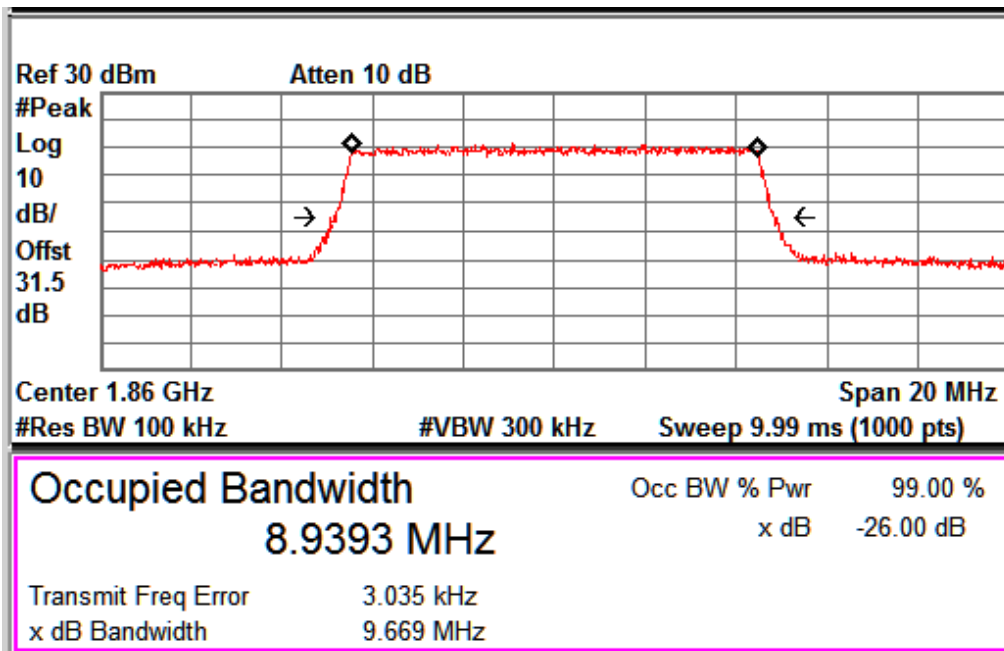

FDD Band 2_Channel Low_10MHz

www.tuv.com

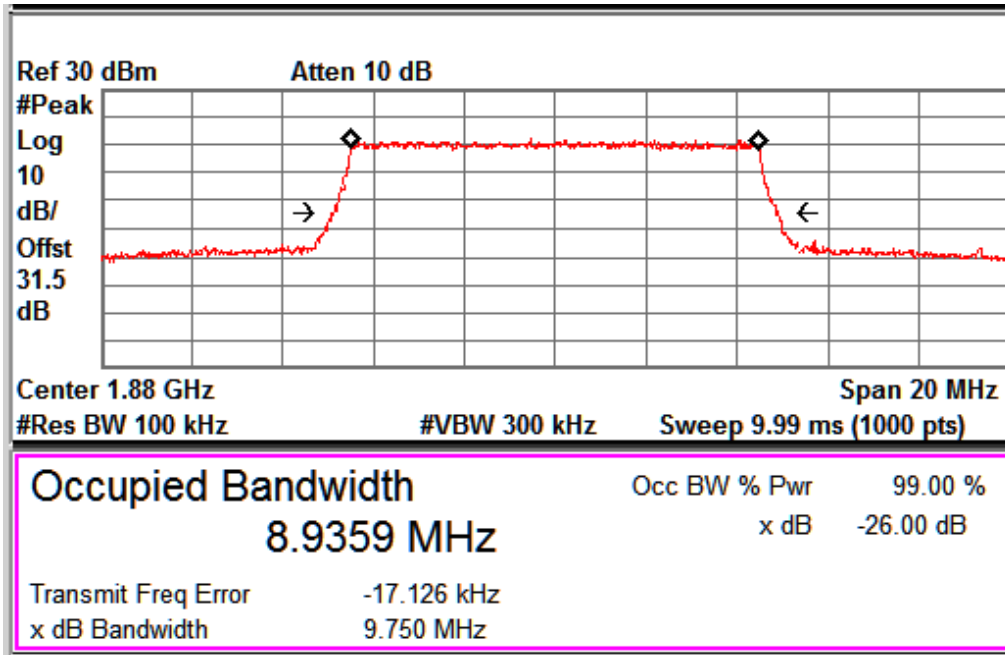

FDD Band 2_Channel Mid_10MHz

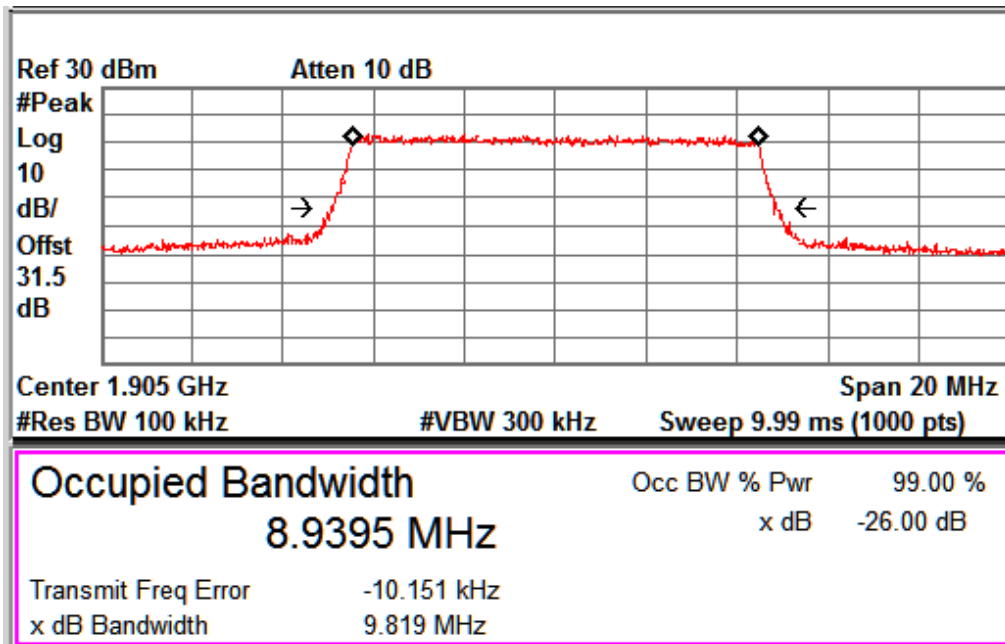

FDD Band 2_Channel High_10MHz

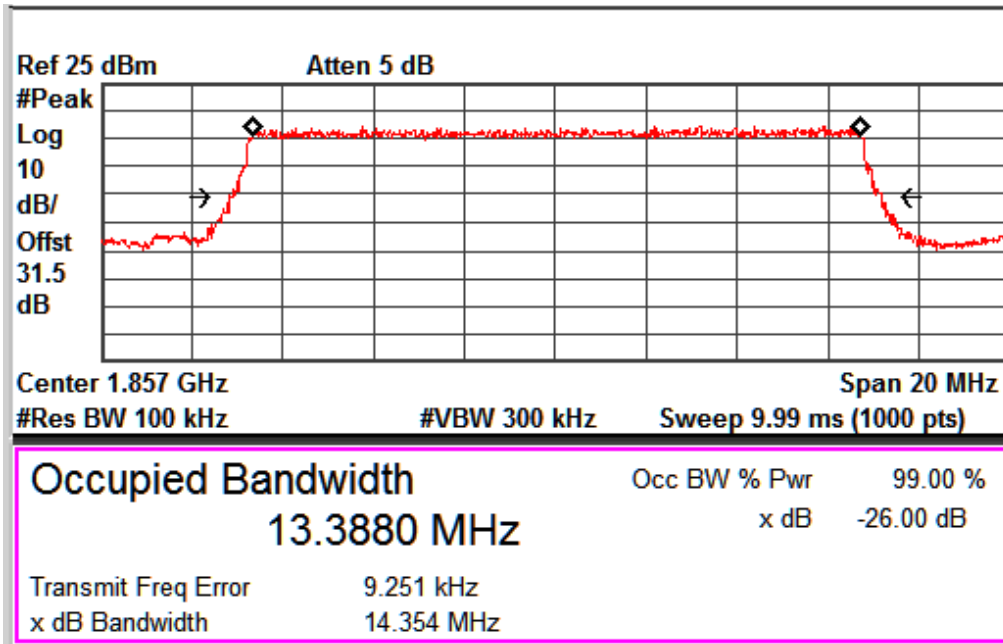

FDD Band 2_Channel Low_15MHz

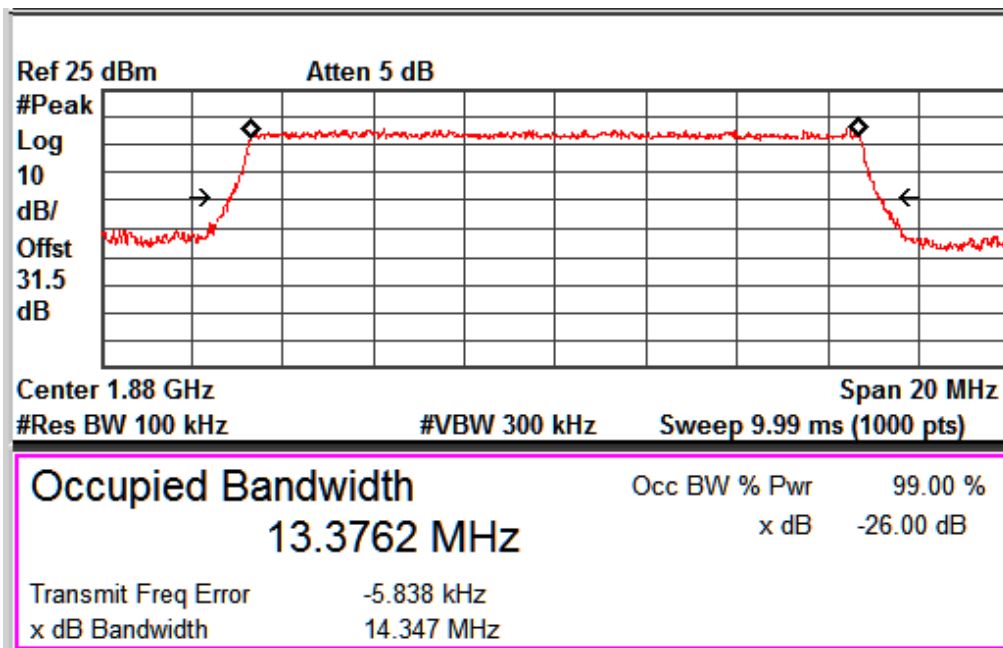

FDD Band 2_Channel Mid_15MHz

www.tuv.com

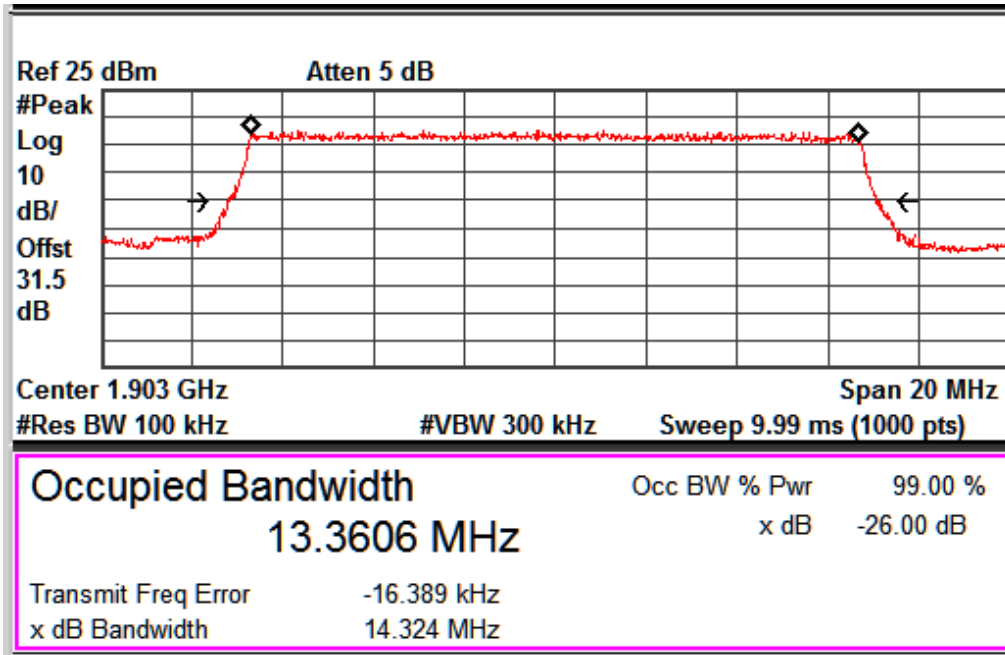

FDD Band 2_Channel High_15MHz

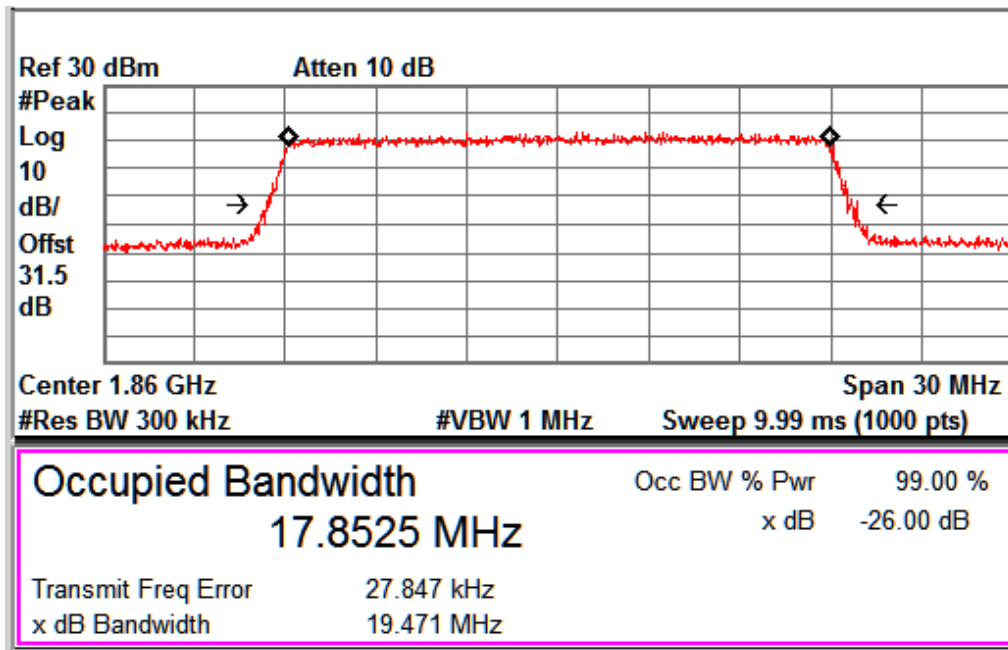

FDD Band 2_Channel Low_20MHz

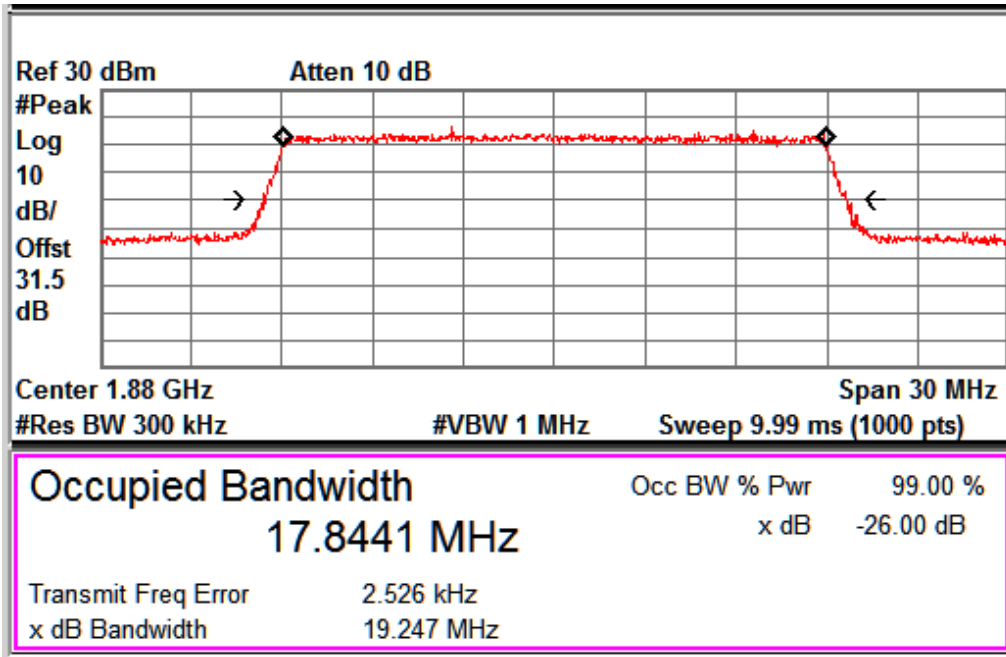

FDD Band 2_Channel Mid_20MHz

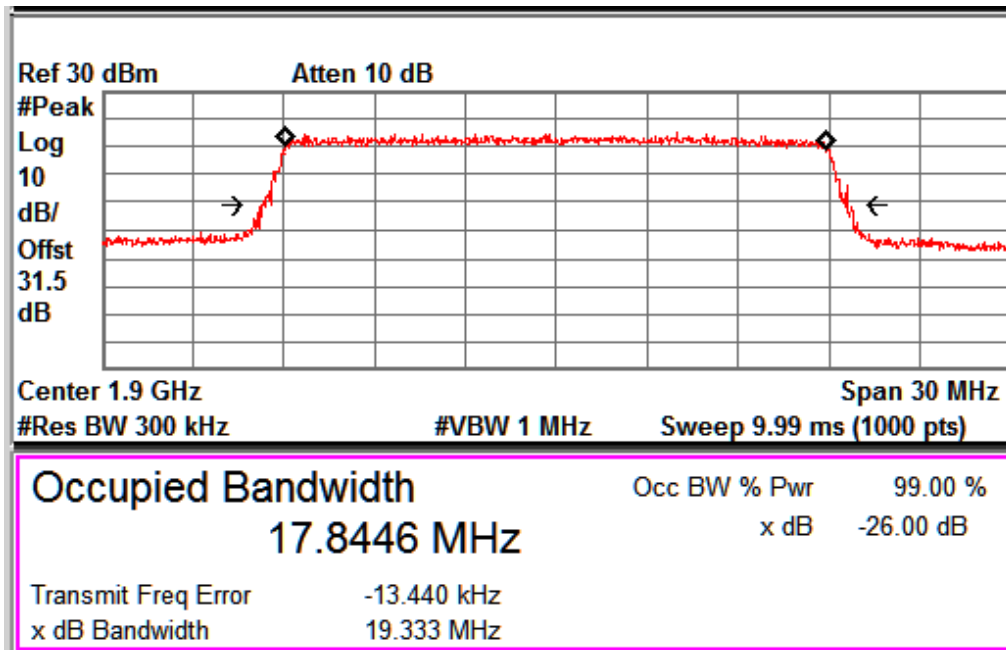

FDD Band 2_Channel High_20MHz

www.tuv.com

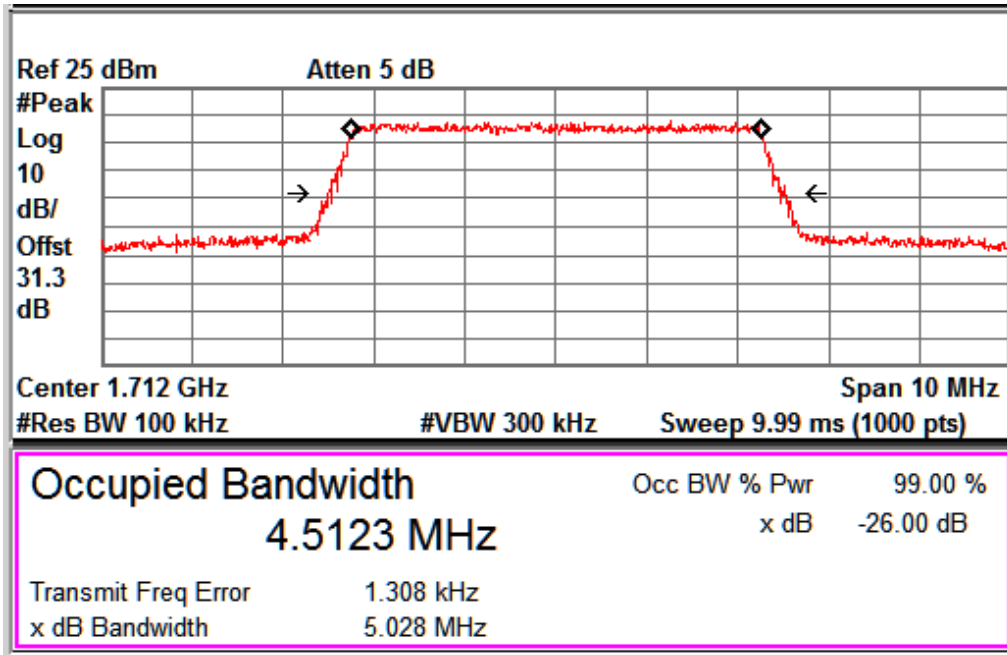

FDD Band 4_Channel Low_5MHz

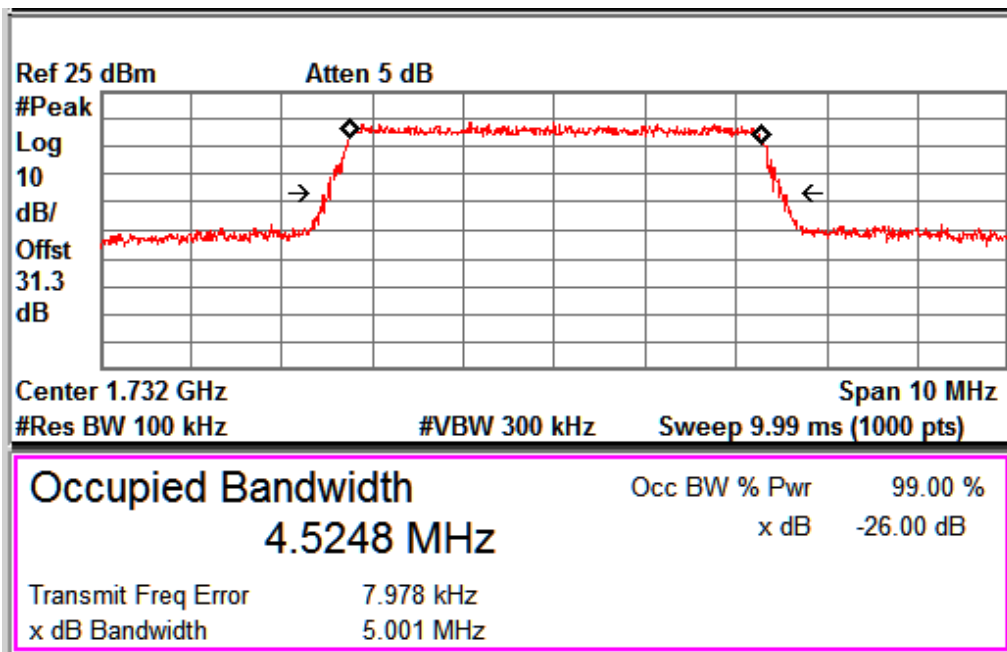

FDD Band 4_Channel Mid_5MHz

www.tuv.com

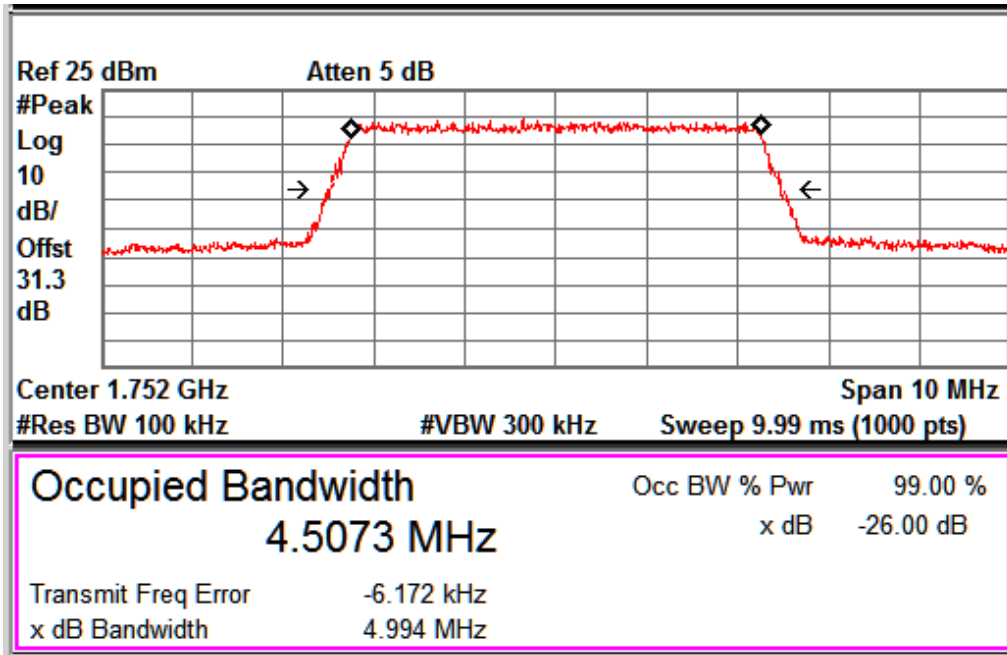

FDD Band 4_Channel High_5MHz

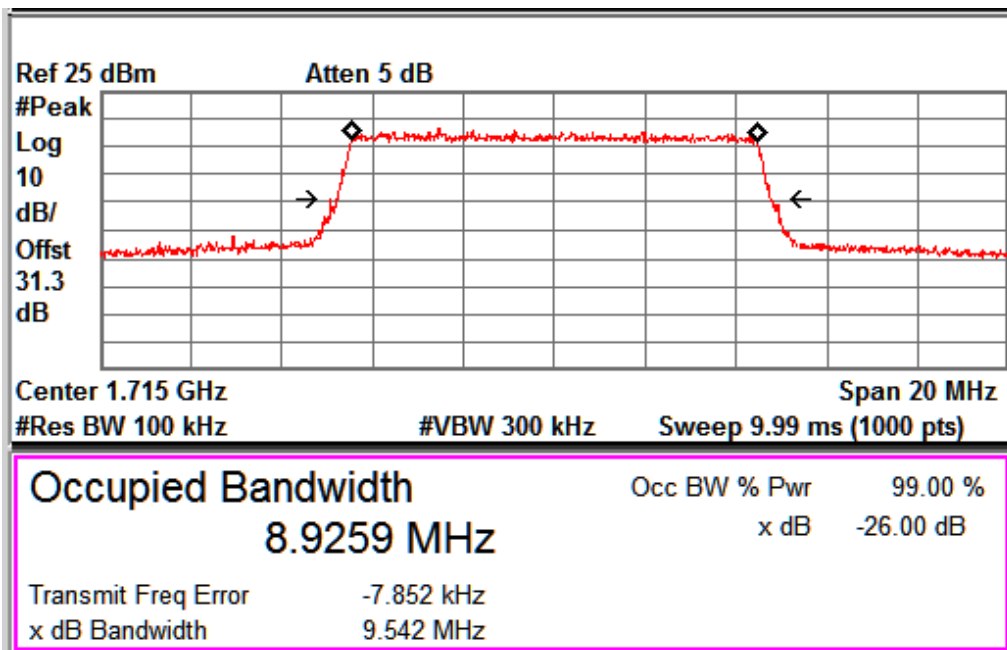

FDD Band 4_Channel Low_10MHz

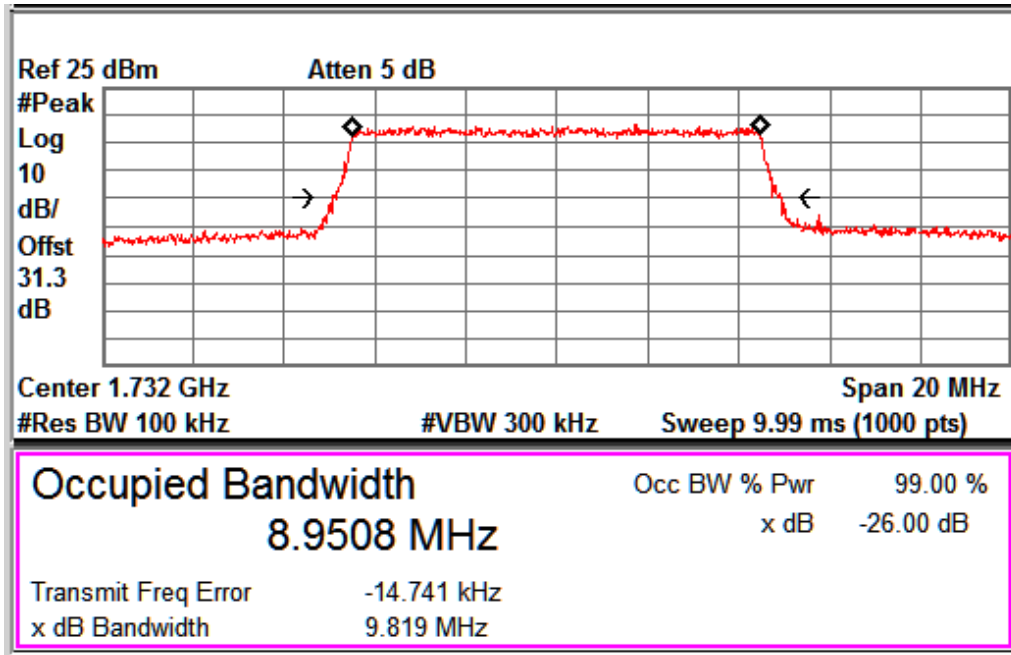

FDD Band 4_Channel Mid_10MHz

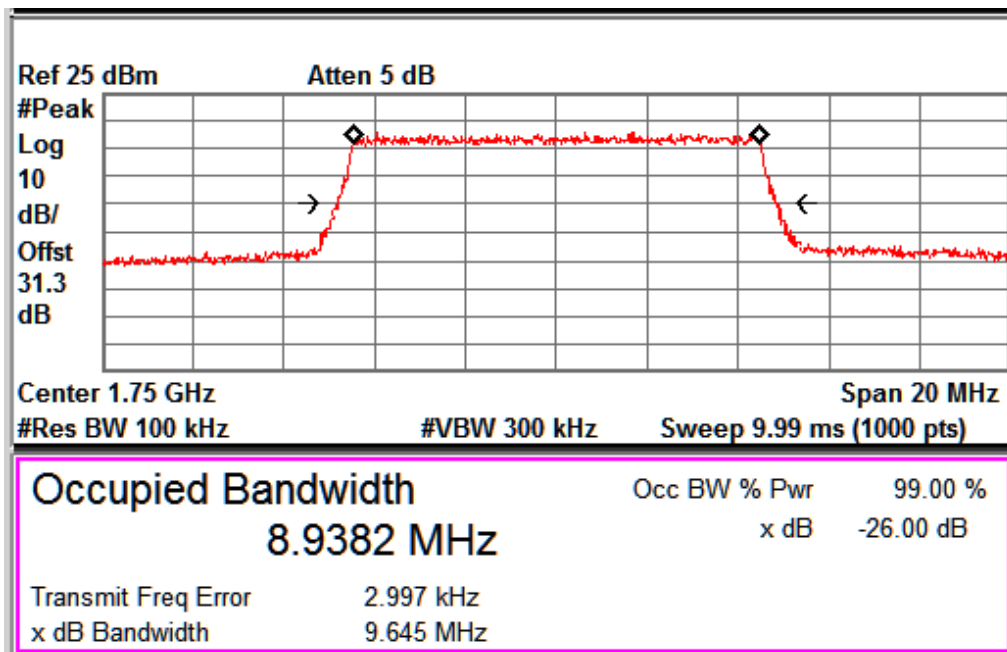

FDD Band 4_Channel High_10MHz

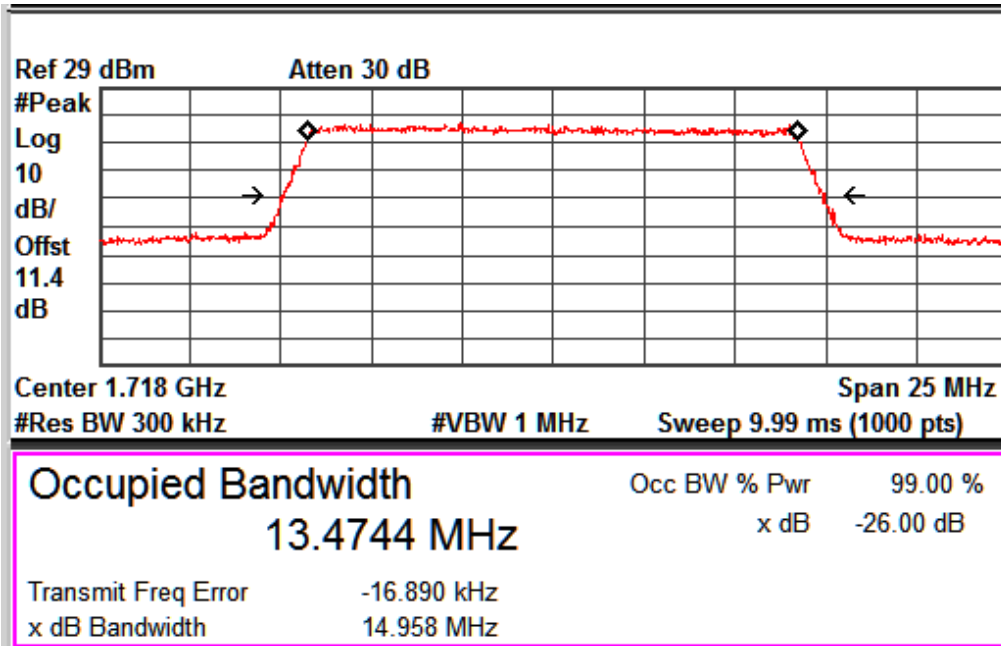
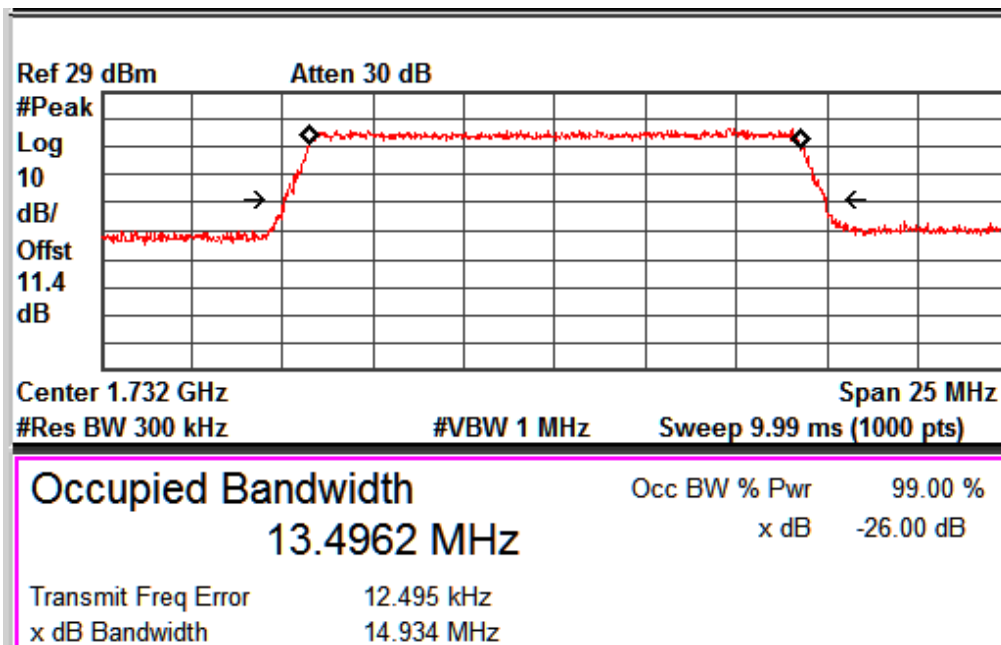
FDD Band 4_Channel Low_15MHz

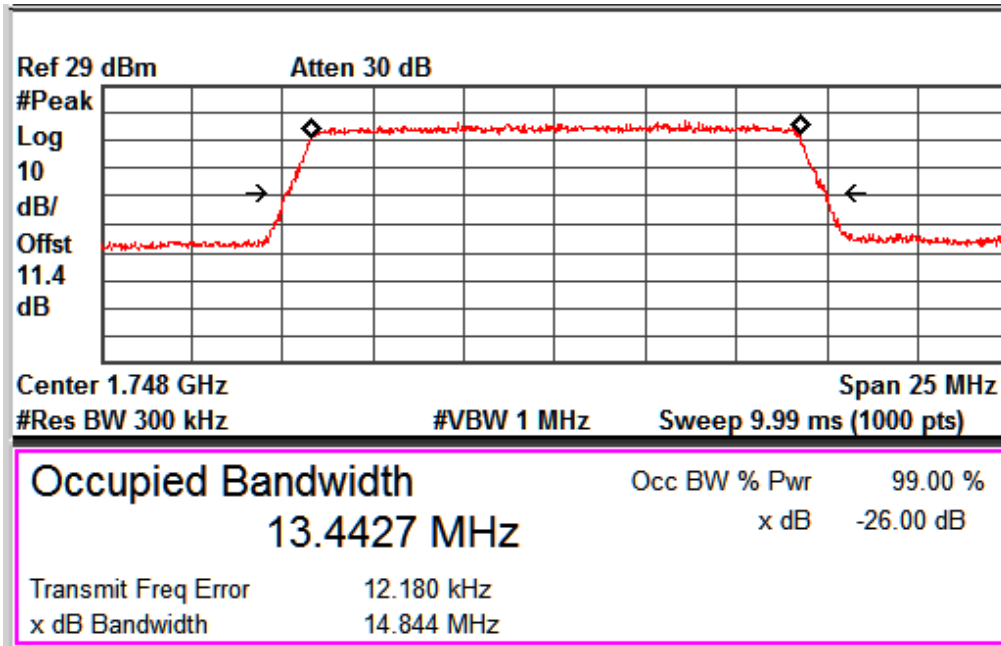
FDD Band 4_Channel Mid_15MHz

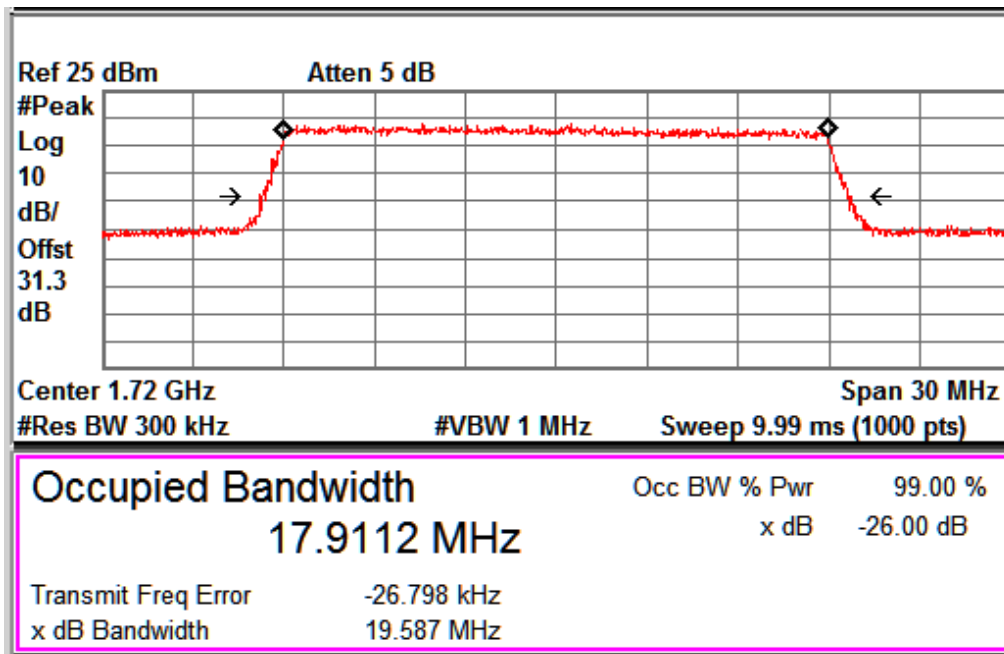

FDD Band 4_Channel High_15MHz



FDD Band 4_Channel Low_20MHz

www.tuv.com

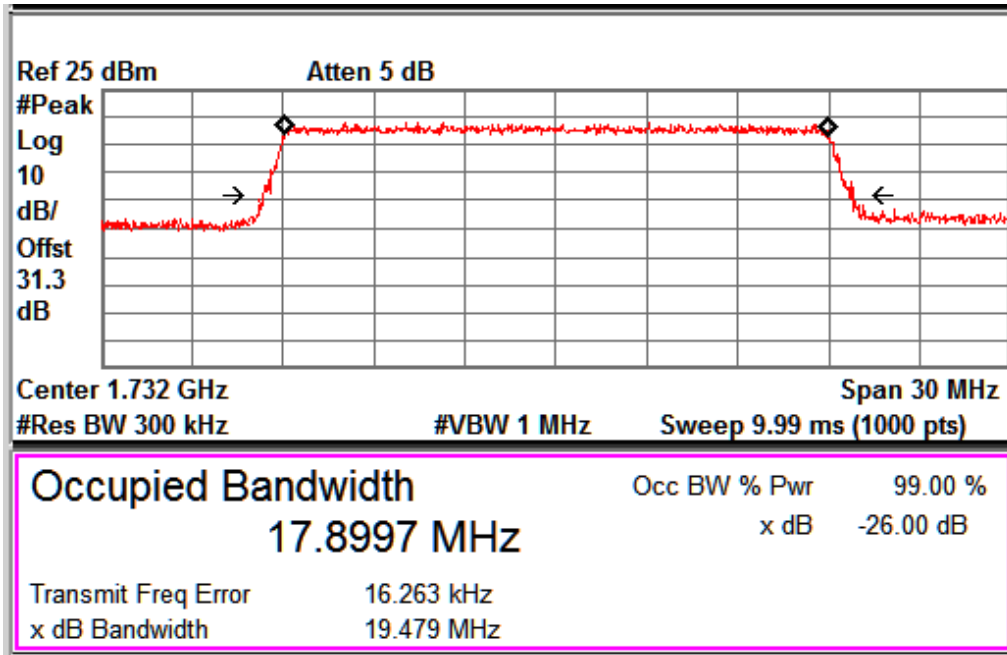

FDD Band 4_Channel Mid_20MHz

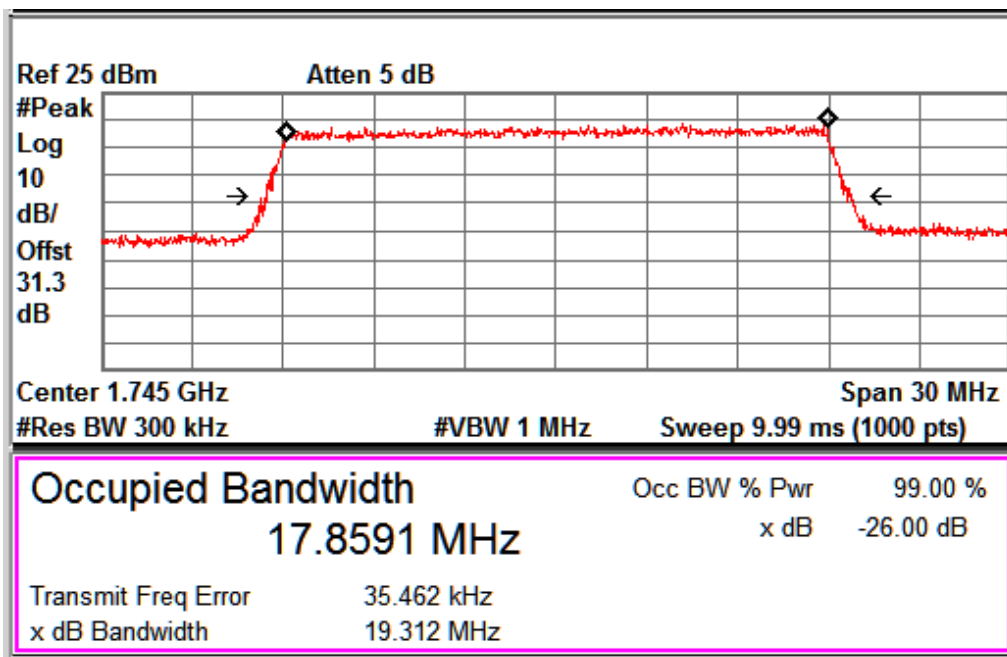

FDD Band 4_Channel High_20MHz

www.tuv.com

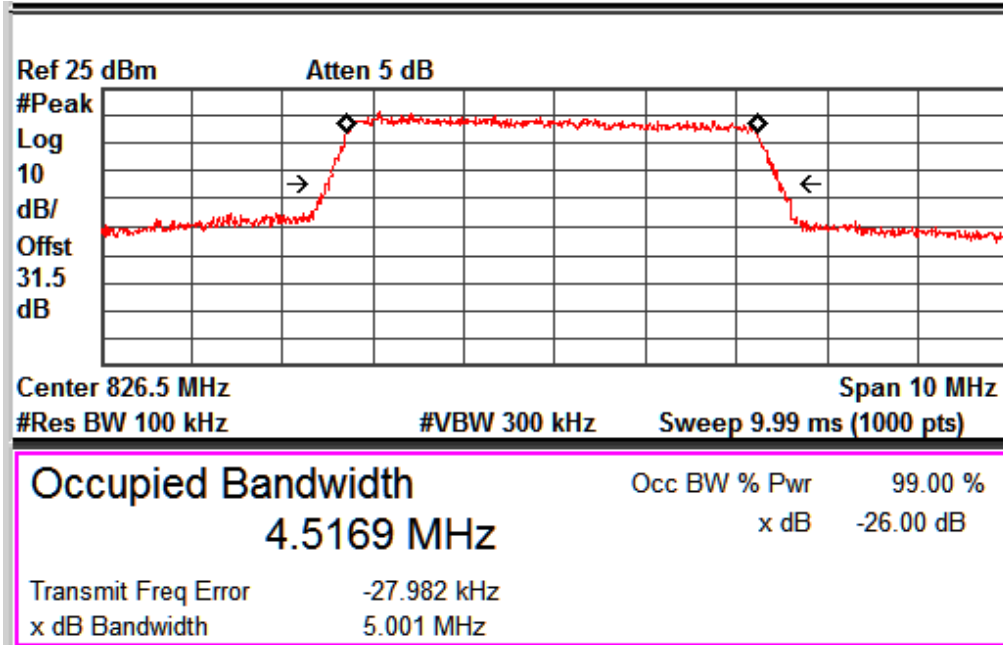

FDD Band 5_Channel Low_5MHz

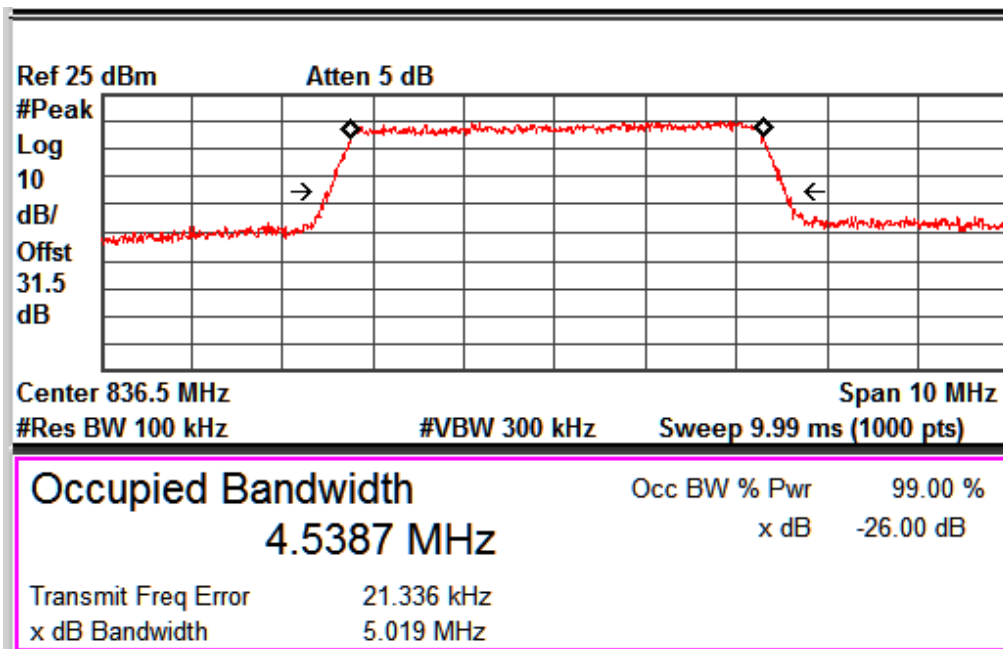

FDD Band 5_Channel Mid_5MHz

www.tuv.com

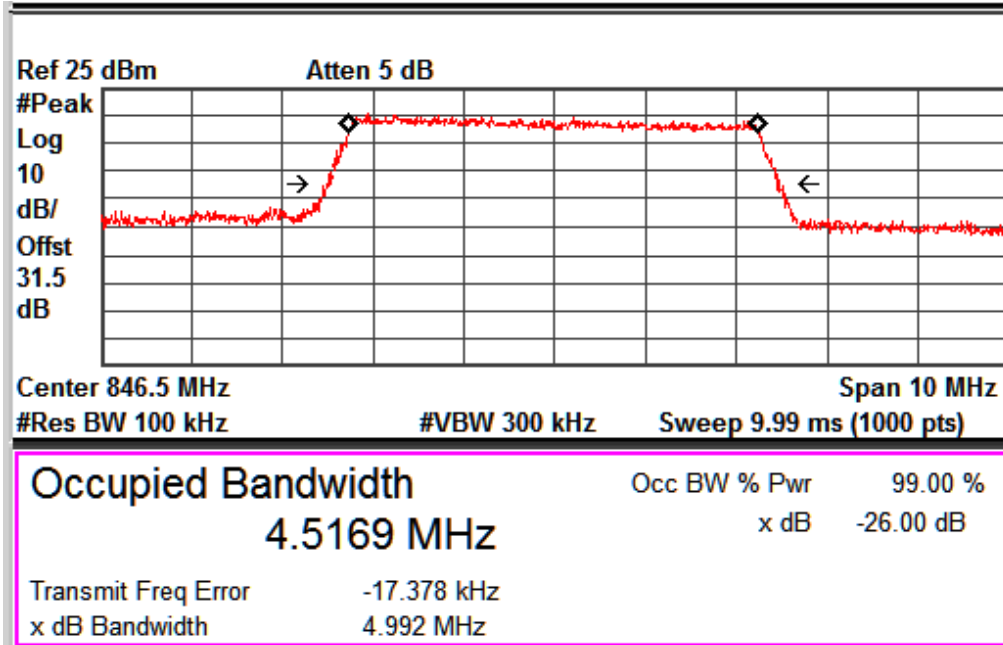

FDD Band 5_Channel High_5MHz

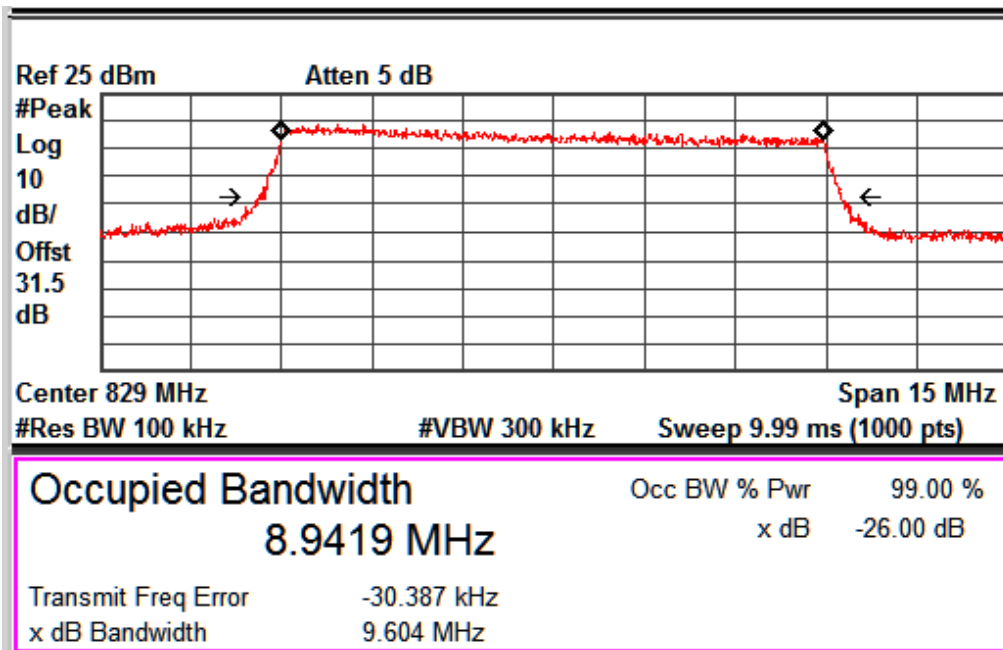

FDD Band 5_Channel Low_10MHz

www.tuv.com

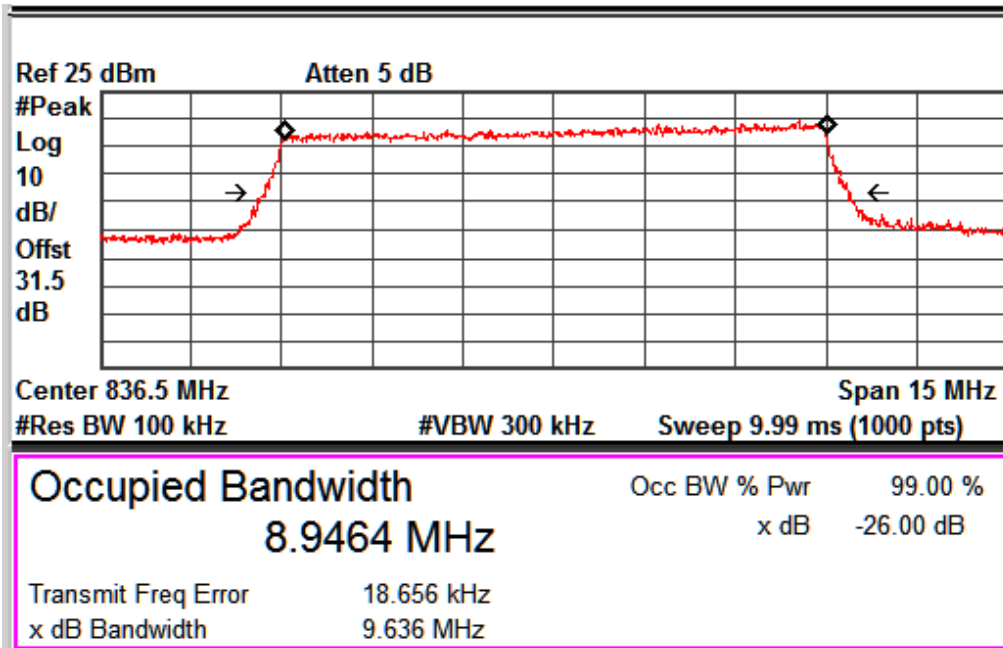

FDD Band 5_Channel Mid_10MHz

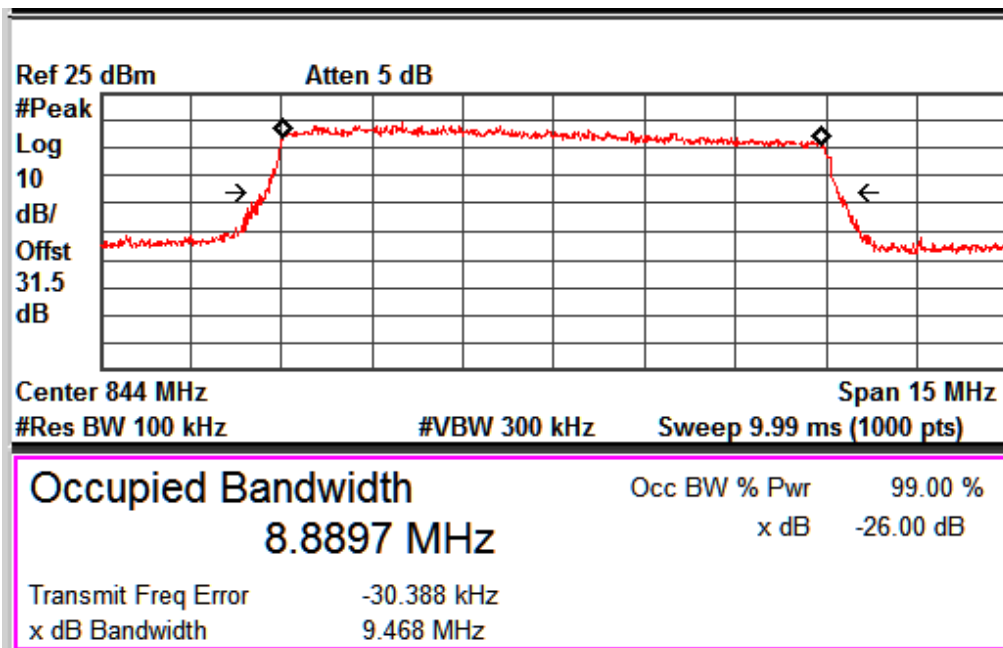

FDD Band 5_Channel High_10MHz

www.tuv.com

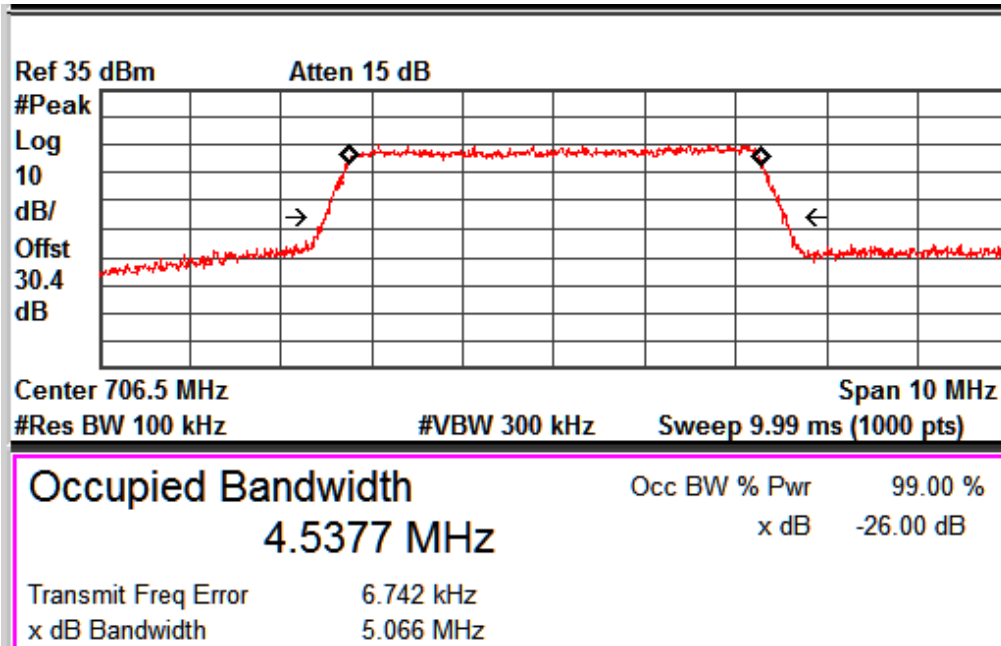

FDD Band 17_Channel Low_5MHz

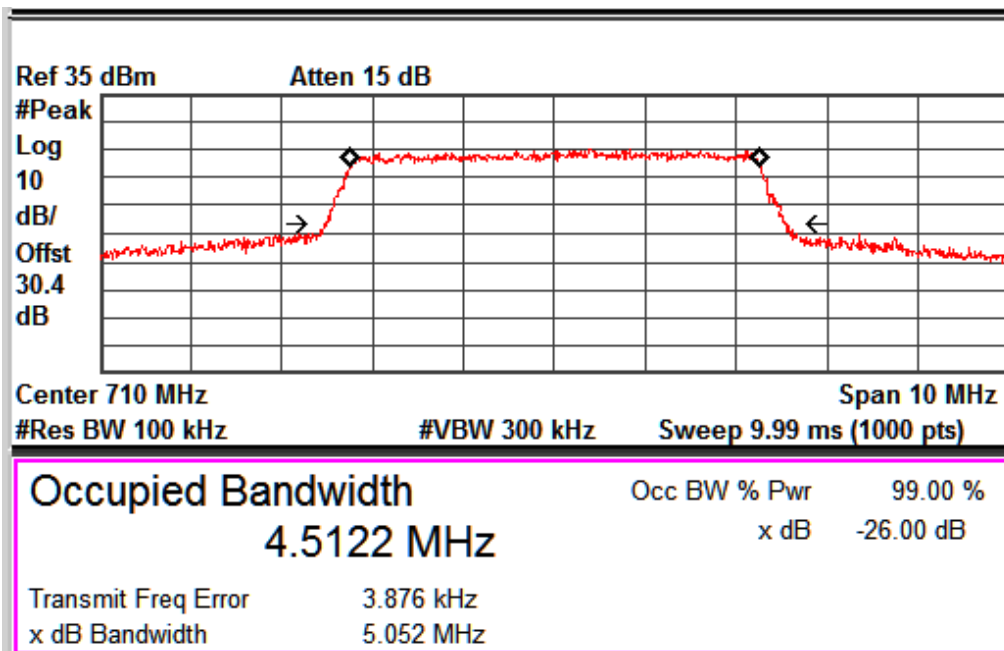

FDD Band 17_Channel Mid_5MHz

www.tuv.com

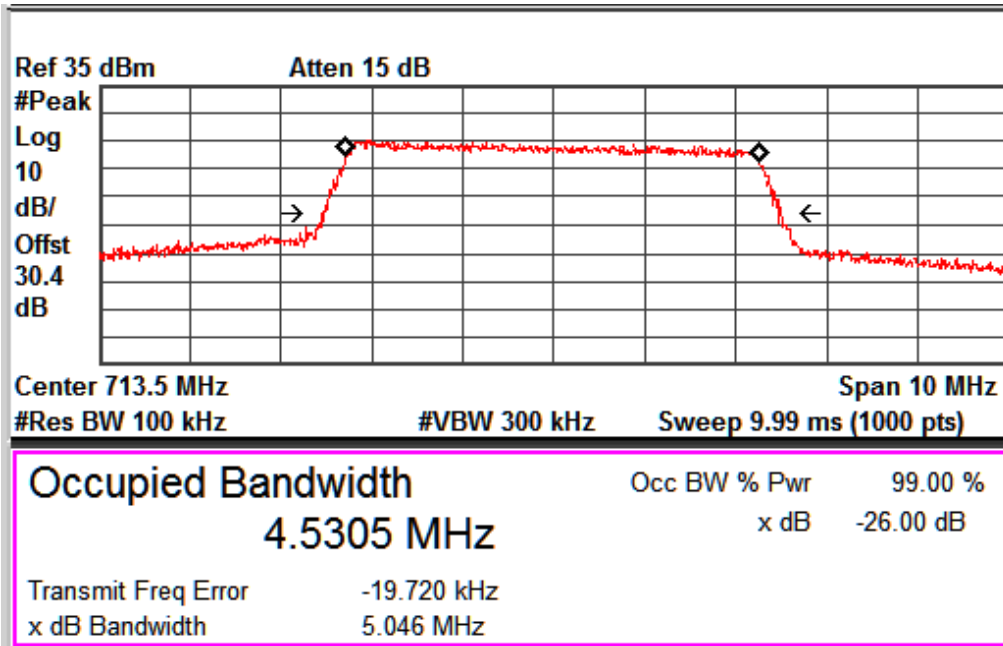

FDD Band 17_Channel High_5MHz

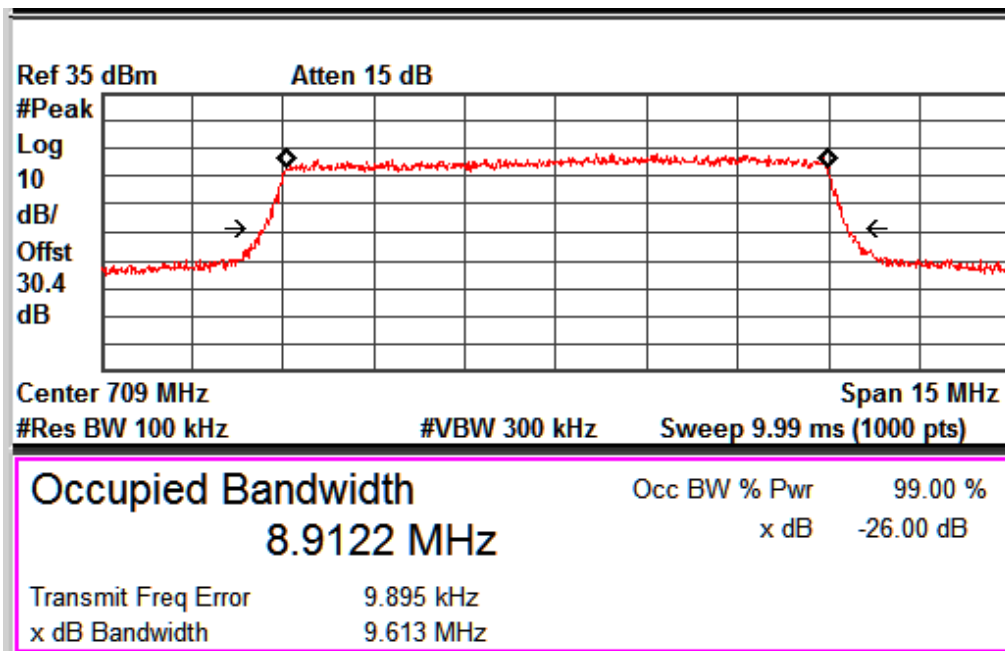

FDD Band 17_Channel Low_10MHz

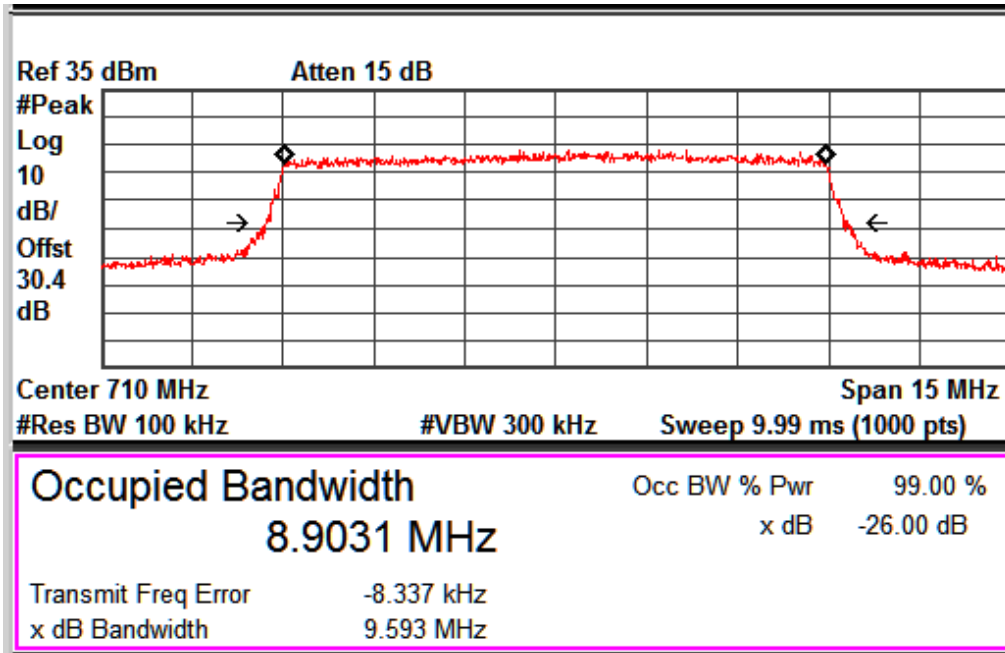
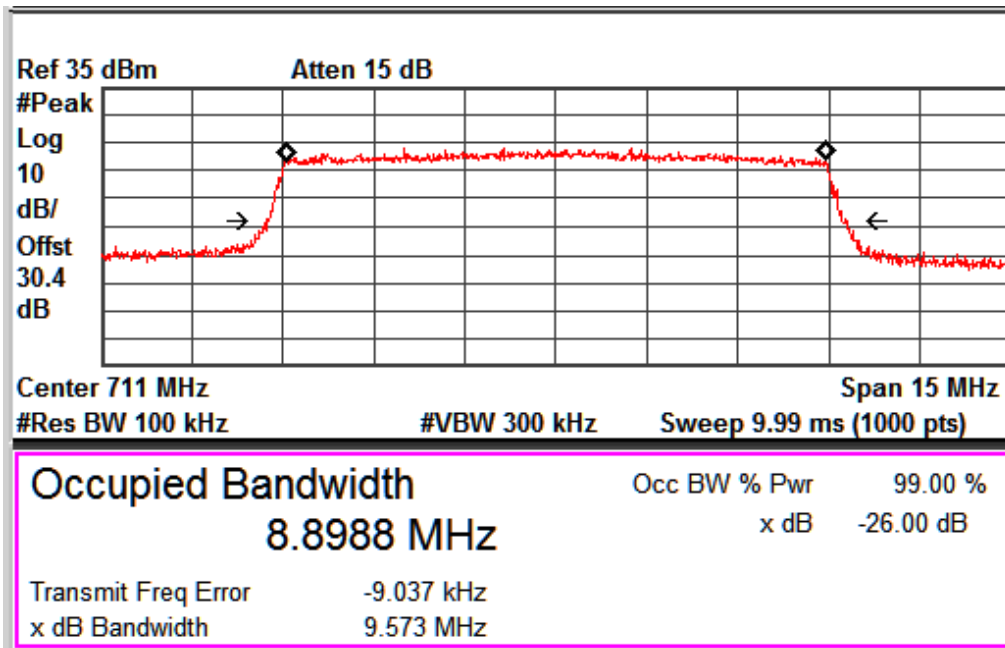
FDD Band 17_Channel Mid_10MHz

FDD Band 17_Channel High_10MHz

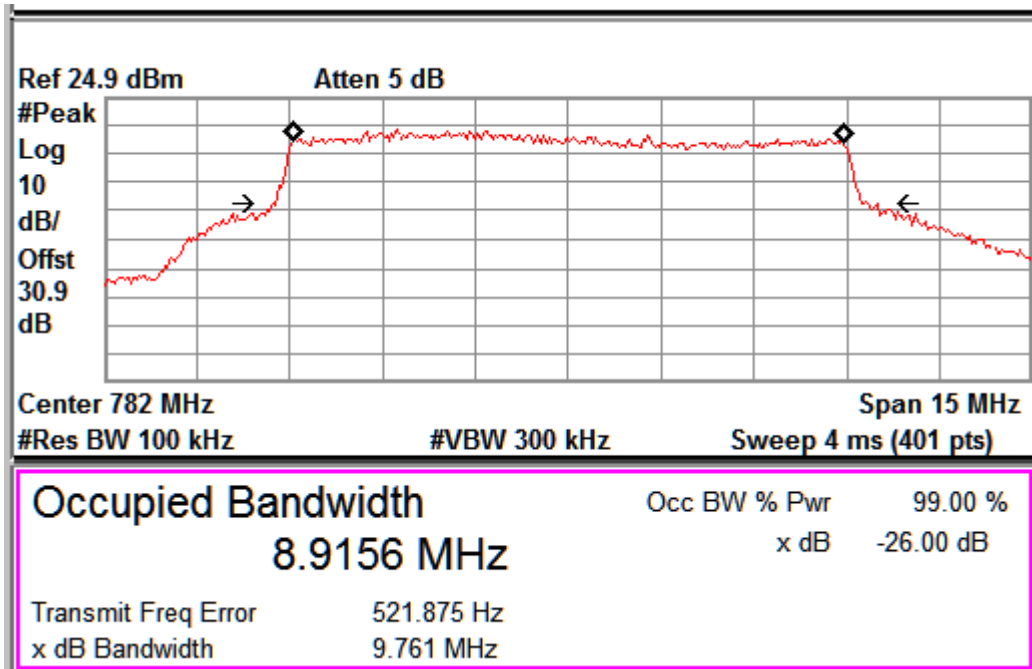
www.tuv.com



FDD Band 13_Channel Mid_10MHz

www.tuv.com

**Band Edge Measurement
Result**

Pass

Specification	FCC Part 2.1051, 2.1057, 22.917(a)(b), 24.238(a)(b), 27.53(h) & RSS 132 Issue 3 section 5.5, RSS 133 Issue 6 section 6.5 (i)(ii), RSS 139 Issue 3 section 6.6(i)(ii), RSS 130 Issue 1 section 4.6
Measurement Bandwidth (RBW)	100 kHz
Detector Function	Average
Requirement	Shall be attenuated below the transmitter power (P in watt) by at least $43+10\log(P)$ dBm,

Test Setup:

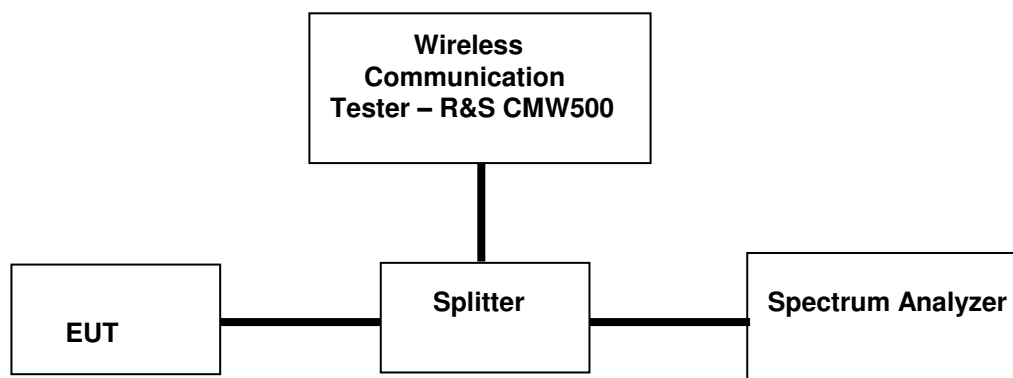

Note: For measurement of Band Edge Measurement, section 6.0 in “971168 D01 Power Meas License Digital Systems v02r02” was used, Attenuator & Cable loss included in the test results

www.tuv.com

Test Results:

Modulation: QPSK						
FDD Band	Bandwidth	Channel	Channel Frequency (MHz)	Band edge Frequency Range (MHz)	Band Edge Value (dBm)	Limit (dBm)
2	5	Low	1852.5	1849-1850	-23.34	-13
		High	1907.5	1910-1911	-24.40	-13
	10	Low	1860	1849-1850	-35.40	-13
		High	1905	1910-1911	-18.47	-13
	15	Low	1857.5	1849-1850	-34.15	-13
		High	1902.5	1910-1911	-34.18	-13
	20	Low	1860	1849-1850	-31.33	-13
		High	1900	1910-1911	-28.89	-13
4	5	Low	1712.5	1709-1710	-25.64	-13
		High	1752.5	1755-1756	-25.88	-13
	10	Low	1715	1709-1710	-17.93	-13
		High	1750	1755-1756	-17.48	-13
	15	Low	1717.5	1709-1710	-33.85	-13
		High	1747.5	1755-1756	-34.15	-13
	20	Low	1720	1709-1710	-30.00	-13
		High	1745	1755-1756	-28.43	-13
5	5	Low	826.5	823-824	-20.77	-13
		High	846.5	849-850	-22.87	-13
	10	Low	829	823-824	-25.30	-13
		High	844	849-850	-33.82	-13
17	5	Low	706.5	703-704	-22.08	-13
		High	713.5	716-717	-25.66	-13
	10	Low	709	703-704	-26.69	-13
		High	711	716-717	-31.68	-13
13	10	Mid	782	776-777	-22.40	-13
		Mid	782	787-789	-20.00	-13

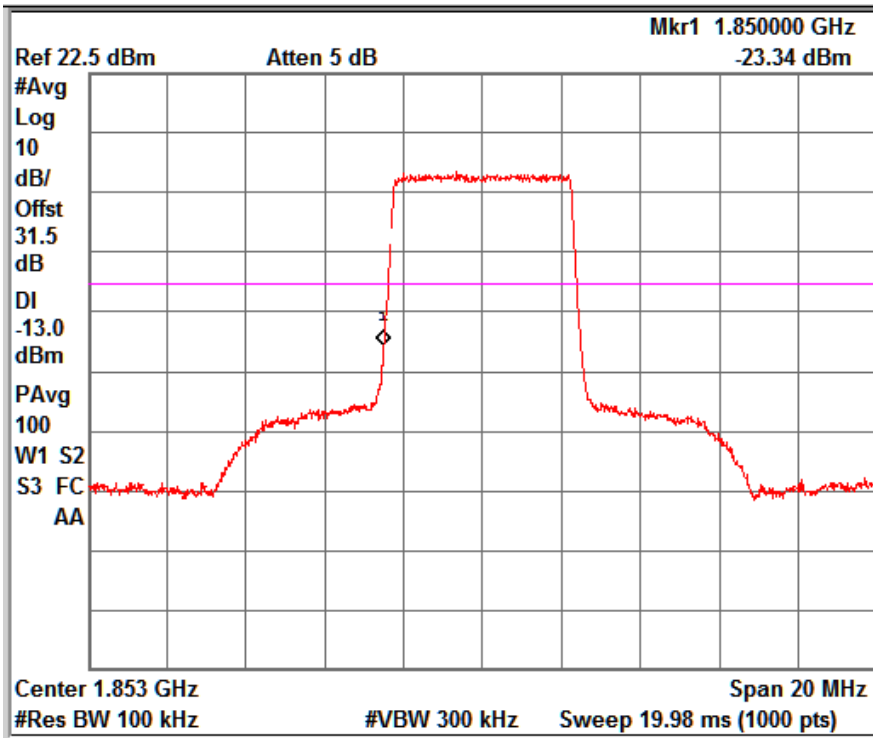
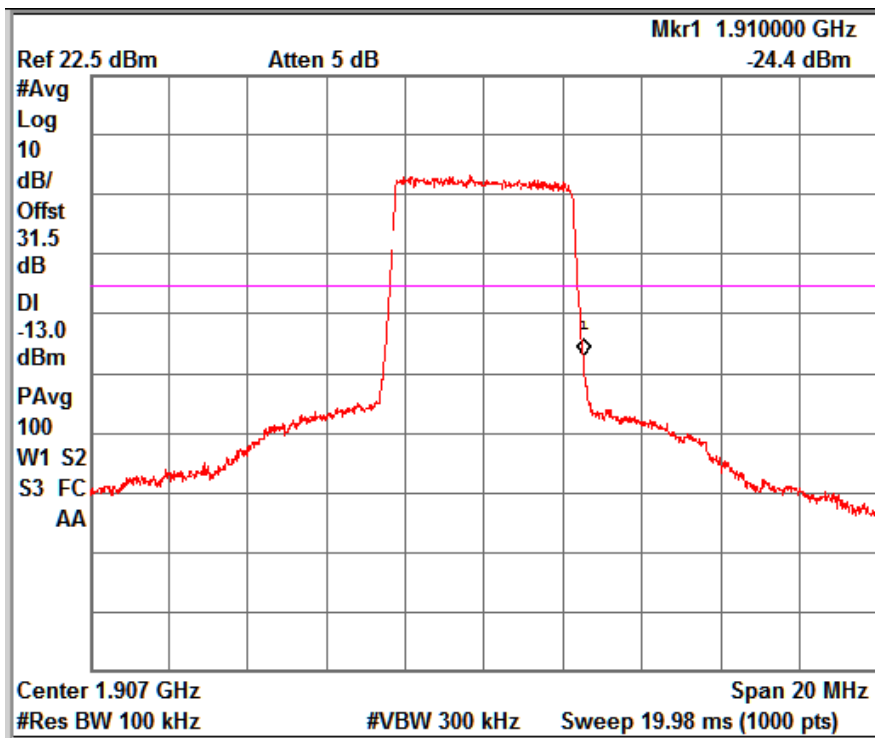
FDD Band 2_Channel Low_5MHz

FDD Band 2_Channel High_5MHz

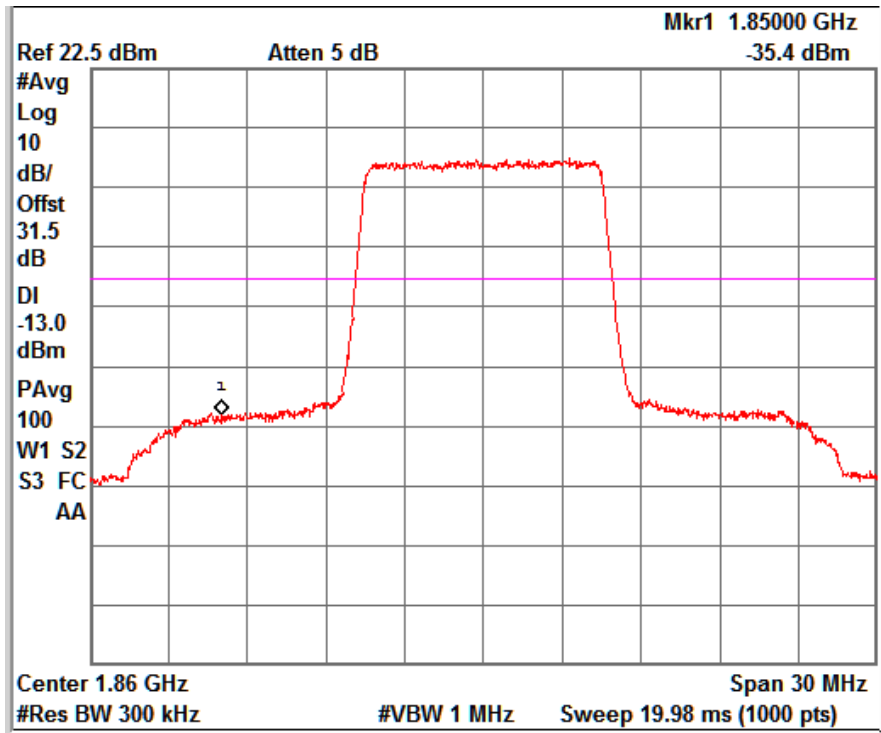
www.tuv.com

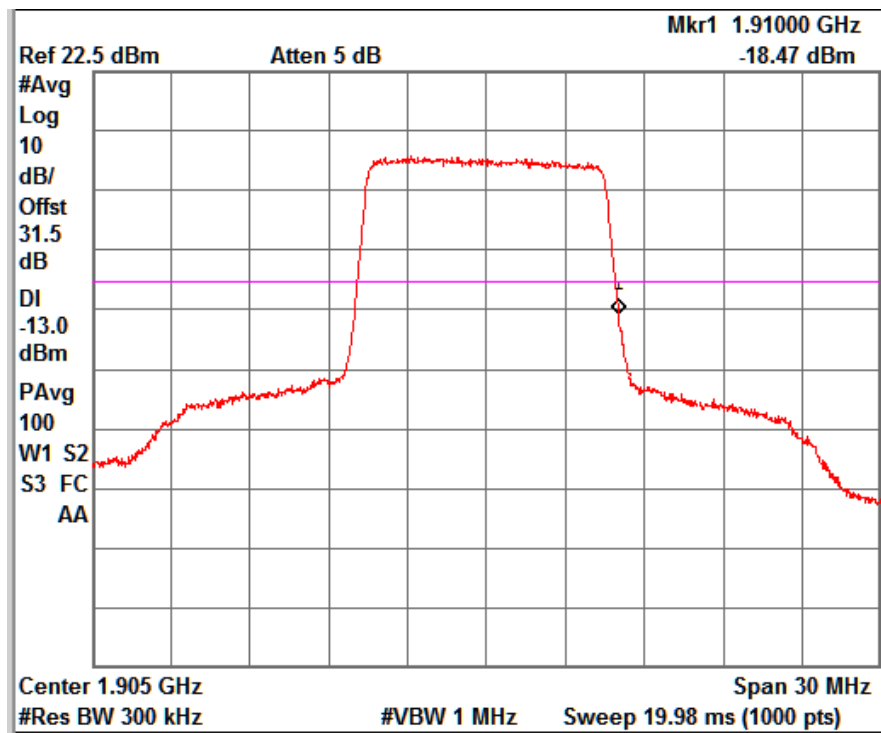

FDD Band 2_Channel Low_10MHz



FDD Band 2_Channel High_10MHz

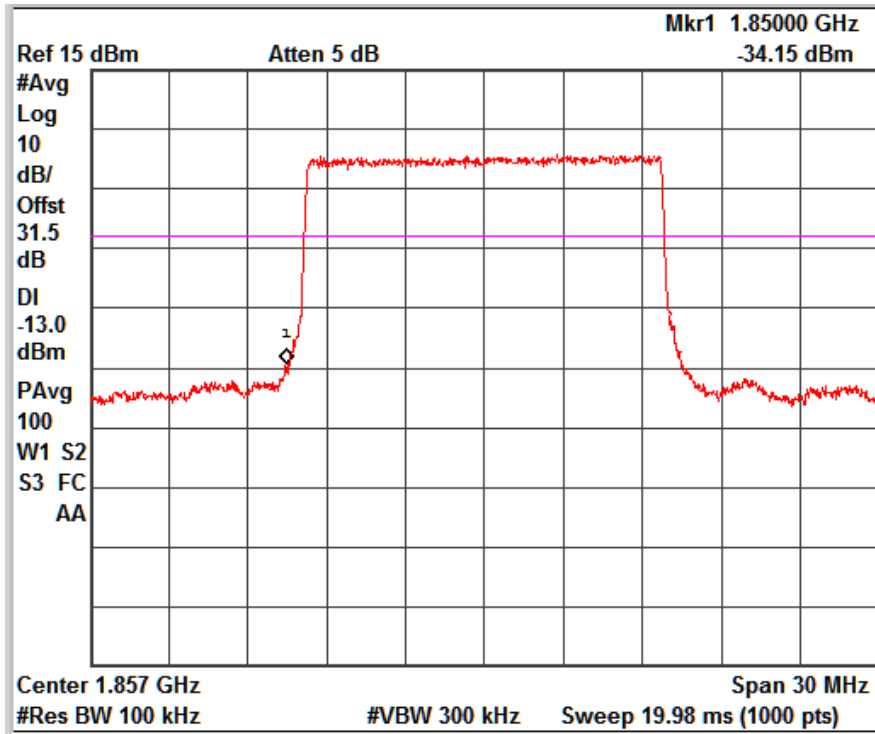

FDD Band 2_Channel Low_15MHz

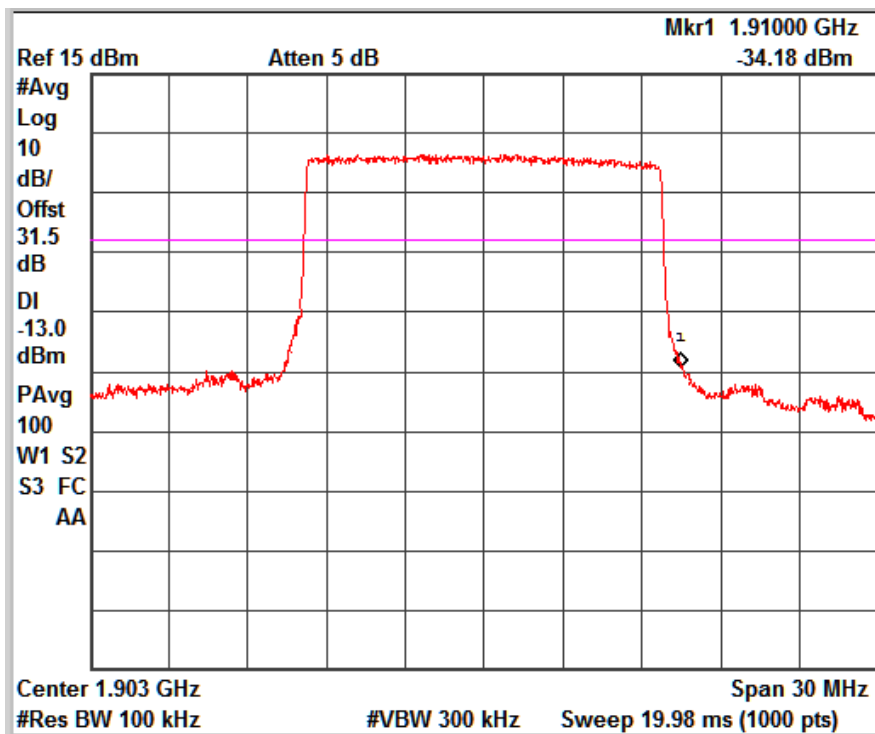

FDD Band 2_Channel High_15MHz

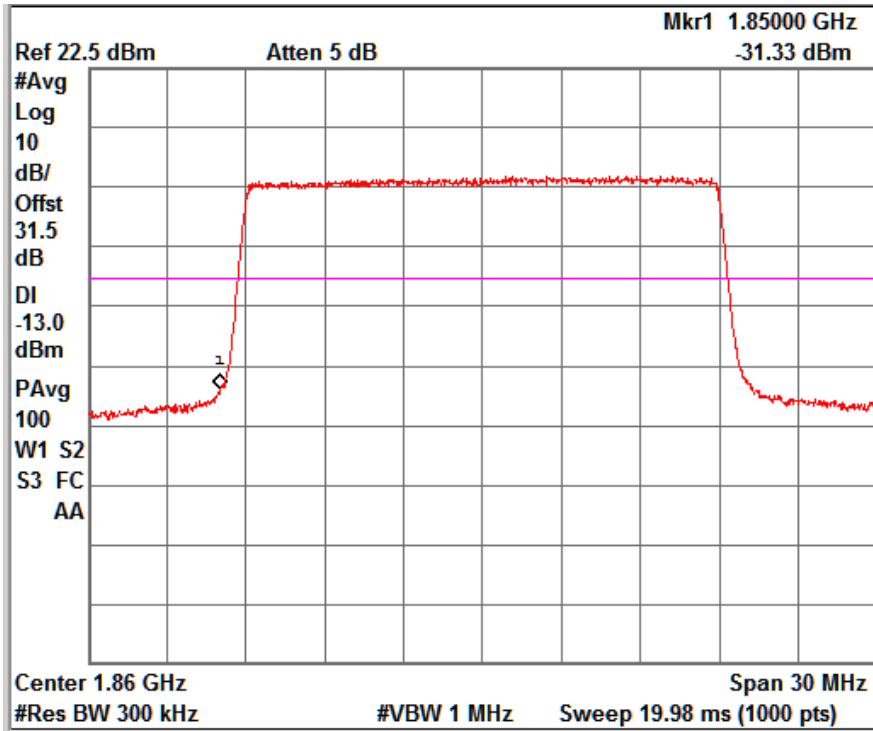

FDD Band 2_Channel Low_20MHz

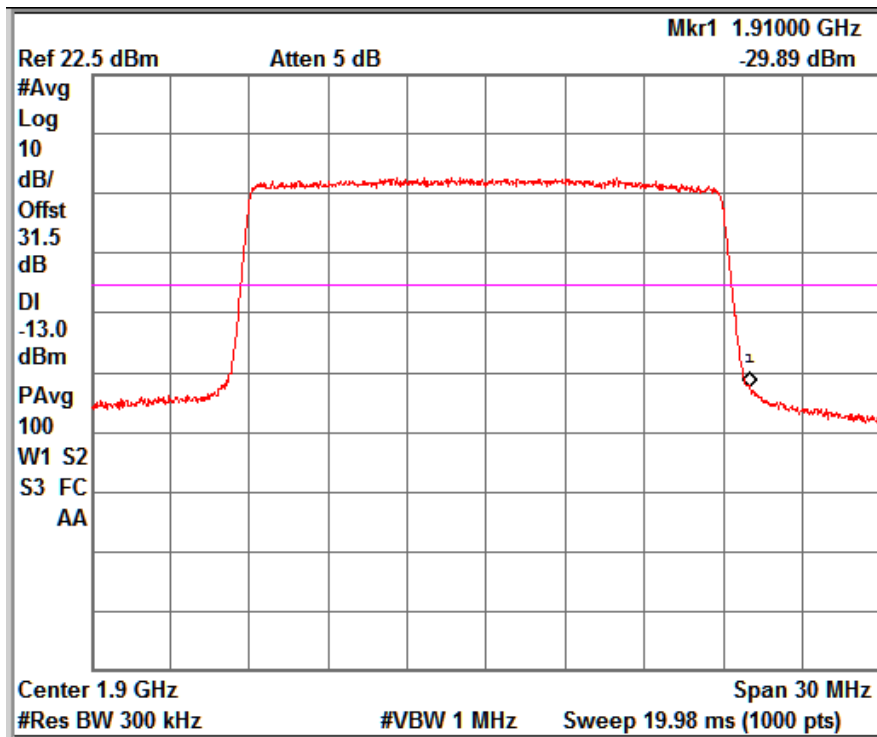

FDD Band 2_Channel High_20MHz

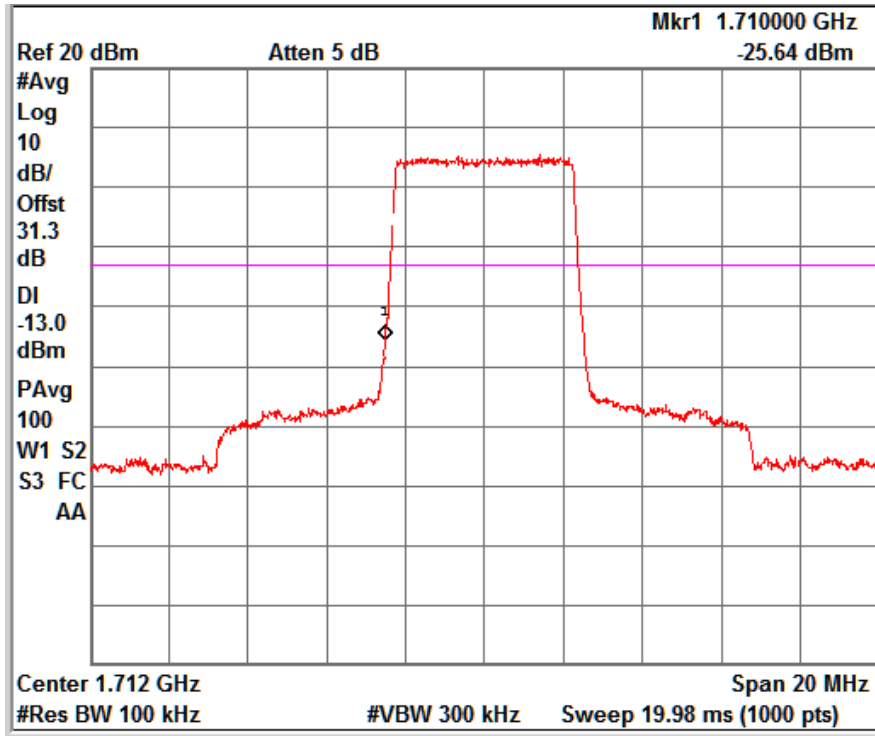
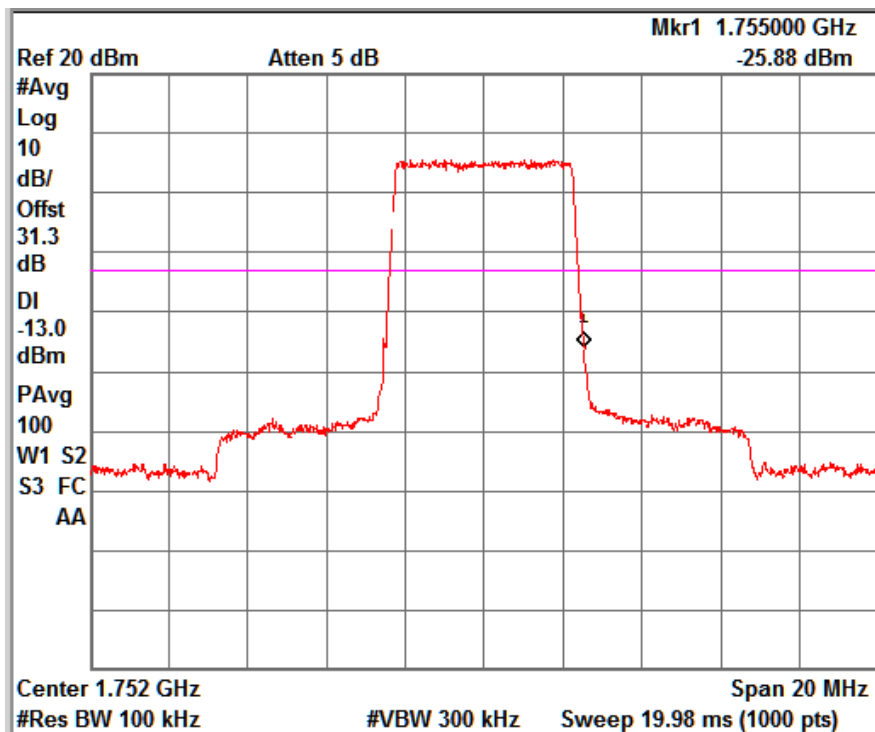
FDD Band 4_Channel Low_5MHz

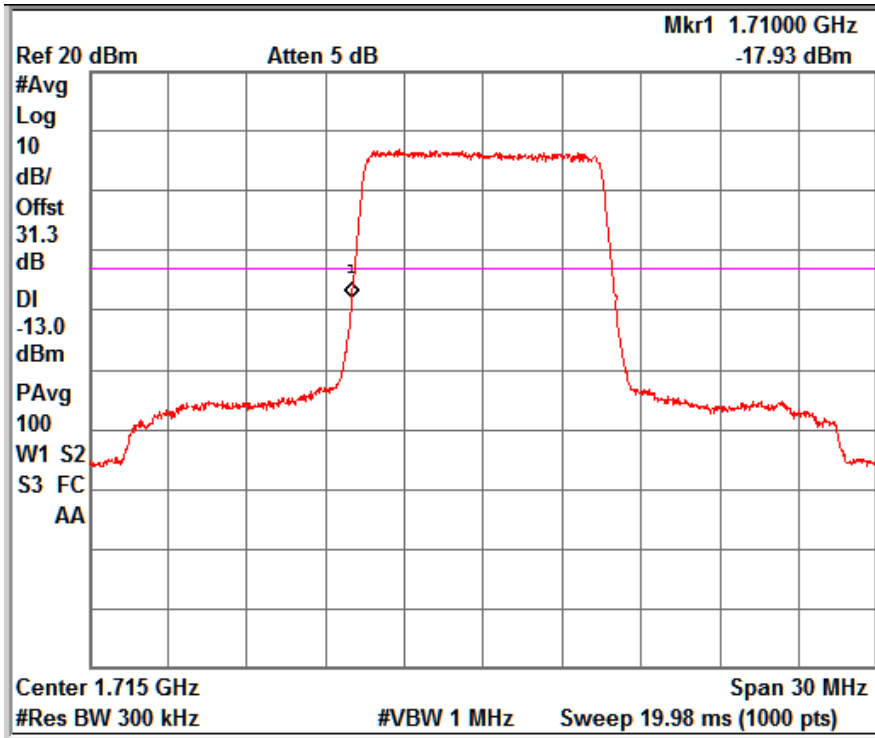
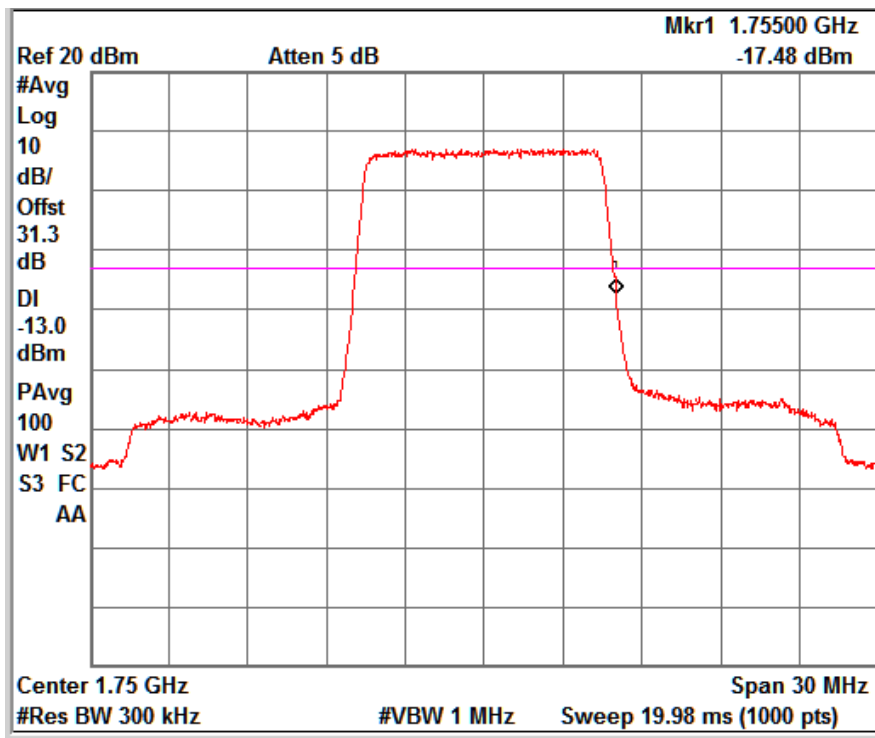
FDD Band 4_Channel High_5MHz

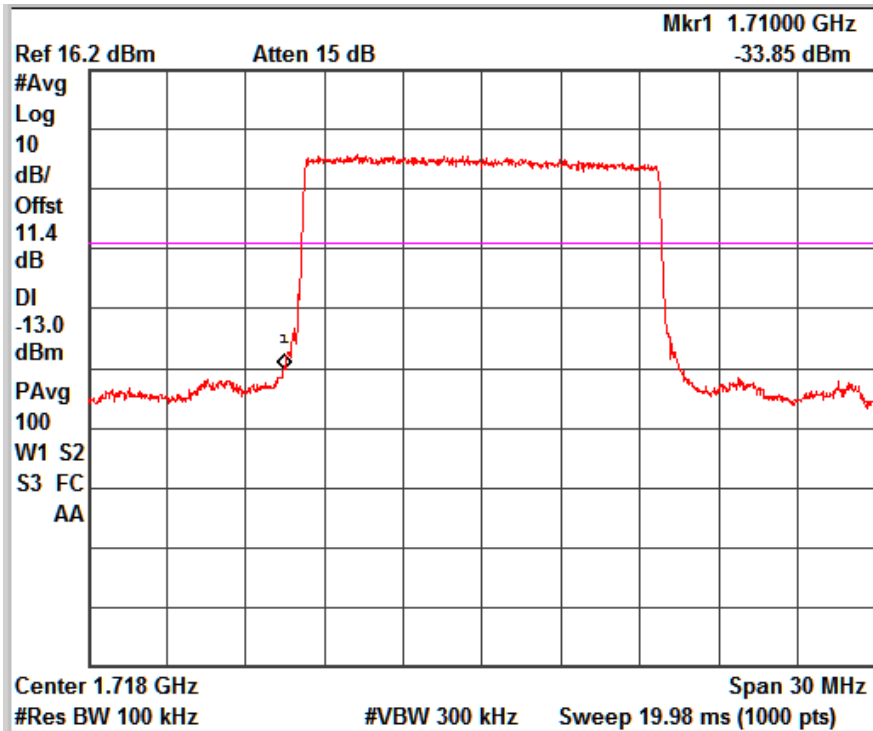

FDD Band 4_Channel Low_10MHz

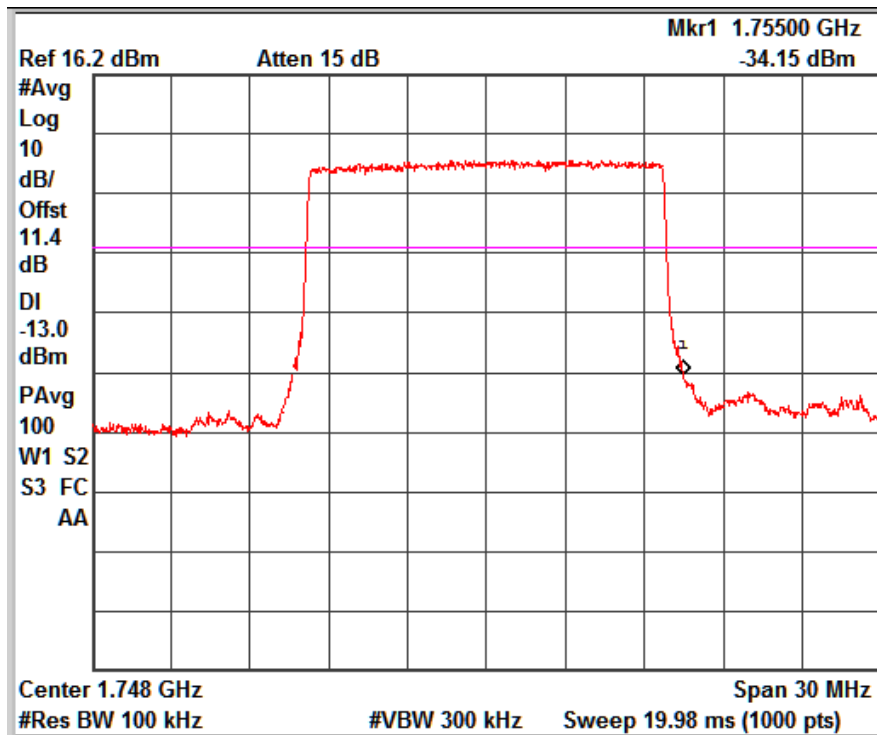
FDD Band4_Channel High_10MHz



FDD Band4_Channel Low_15MHz

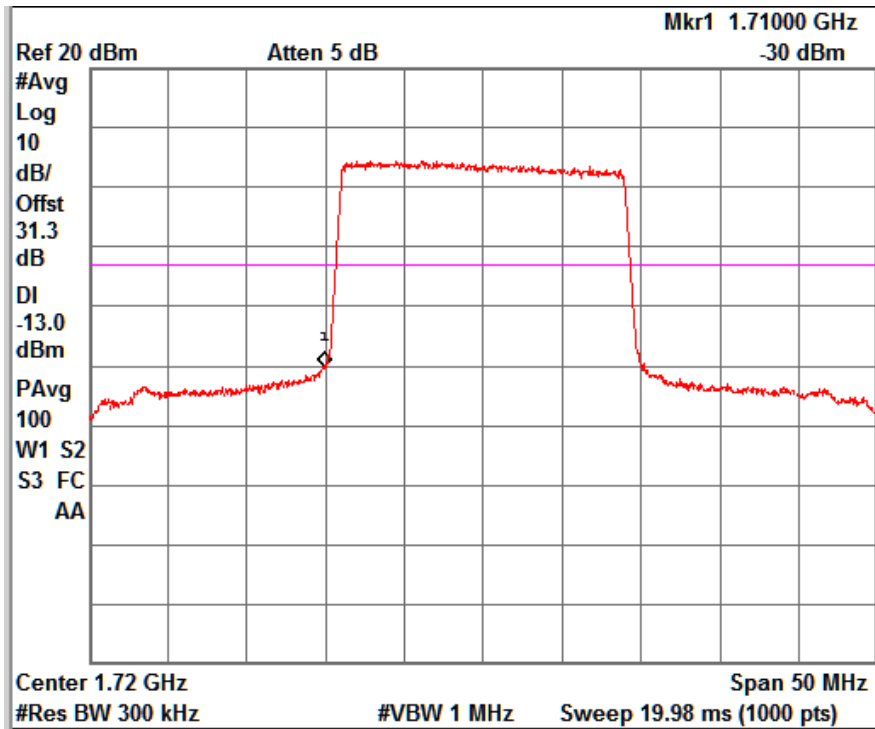

FDD Band4_Channel High_15MHz



FDD Band 4_Channel Low_20MHz

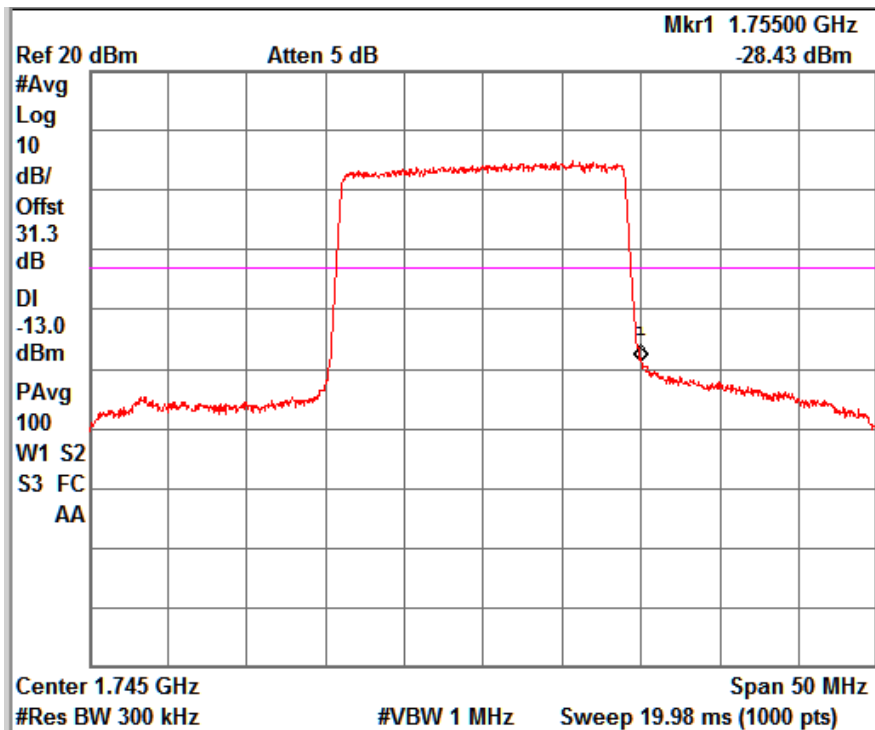

FDD Band 4_Channel High_20MHz

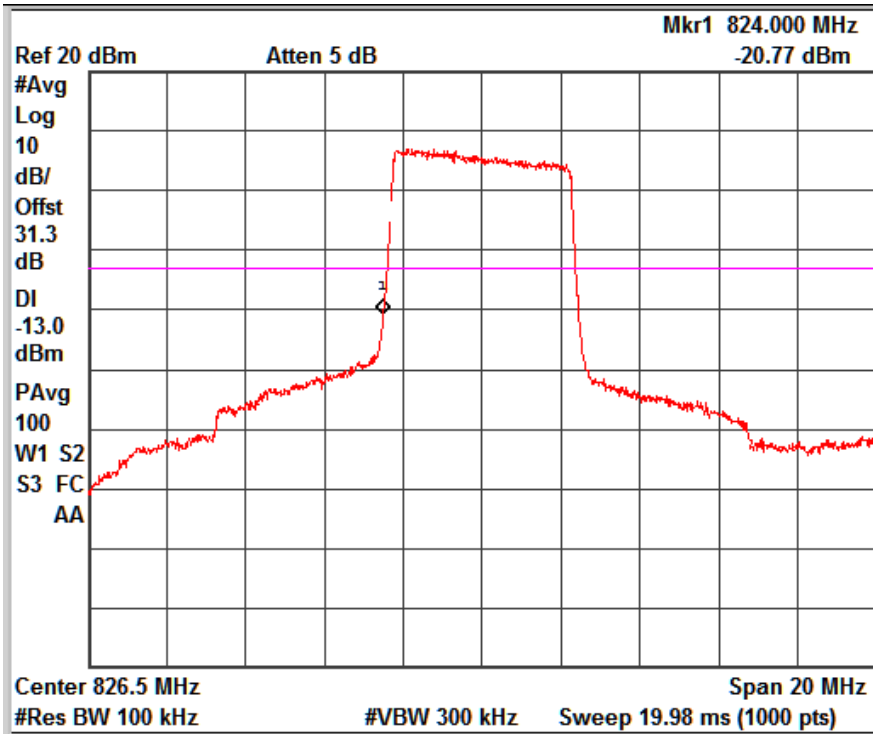
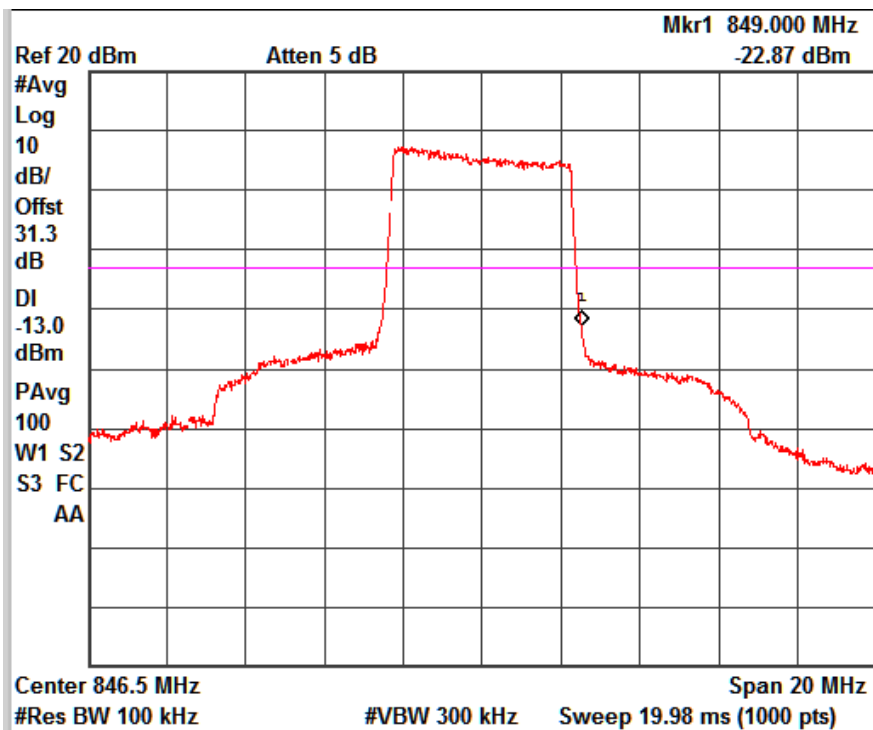
FDD Band 5_Channel Low_5MHz

FDD Band 5_Channel High_5MHz

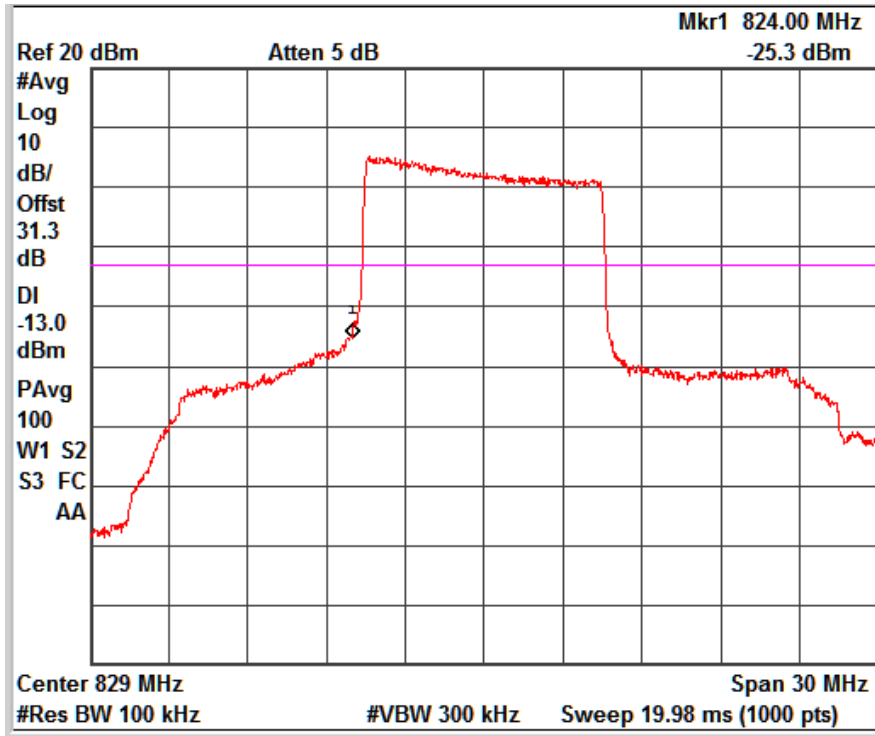
www.tuv.com

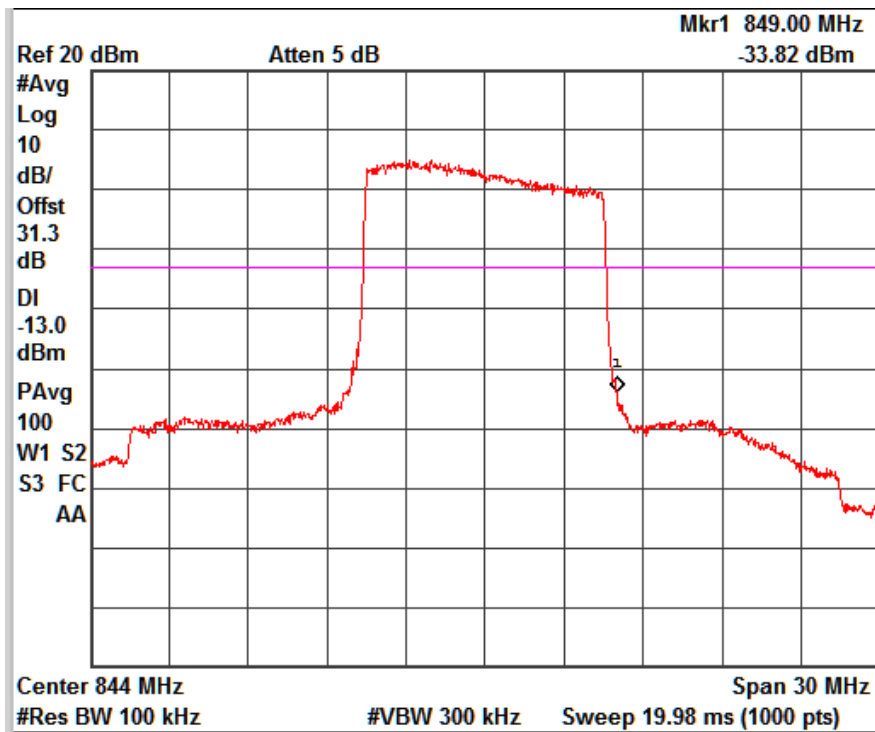

FDD Band 5_Channel Low_10MHz



FDD Band 5_Channel High_10MHz

www.tuv.com

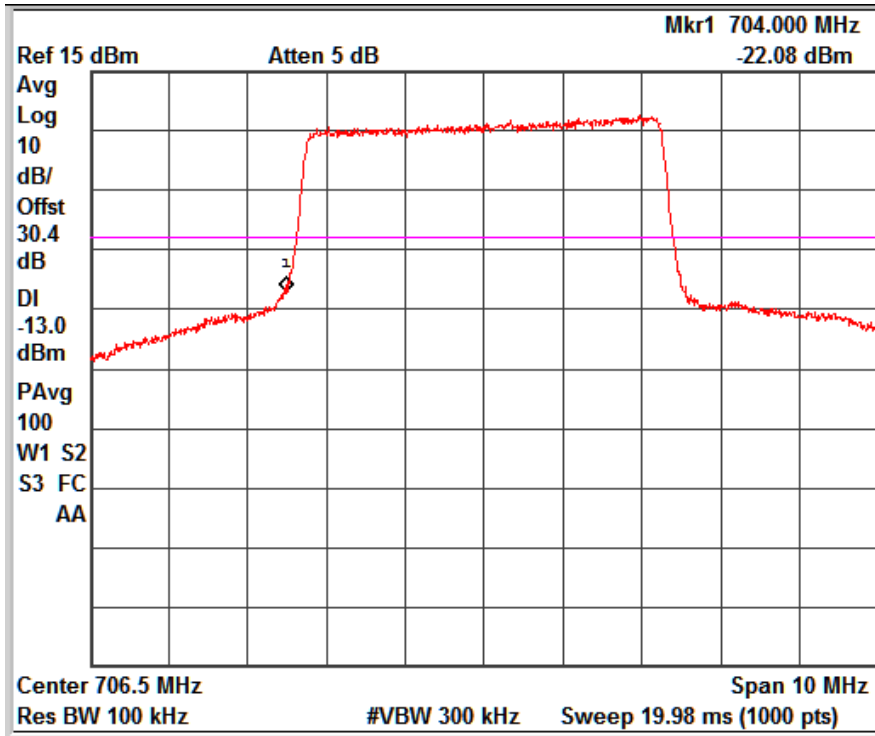

FDD Band 17_Channel Low_5MHz

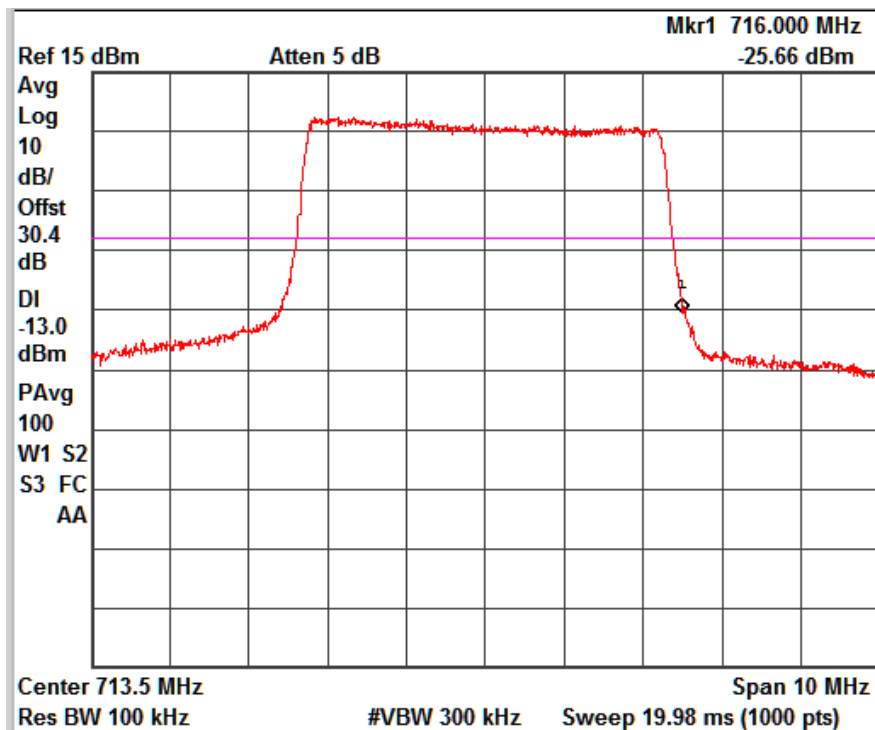

FDD Band 17_Channel High_5MHz

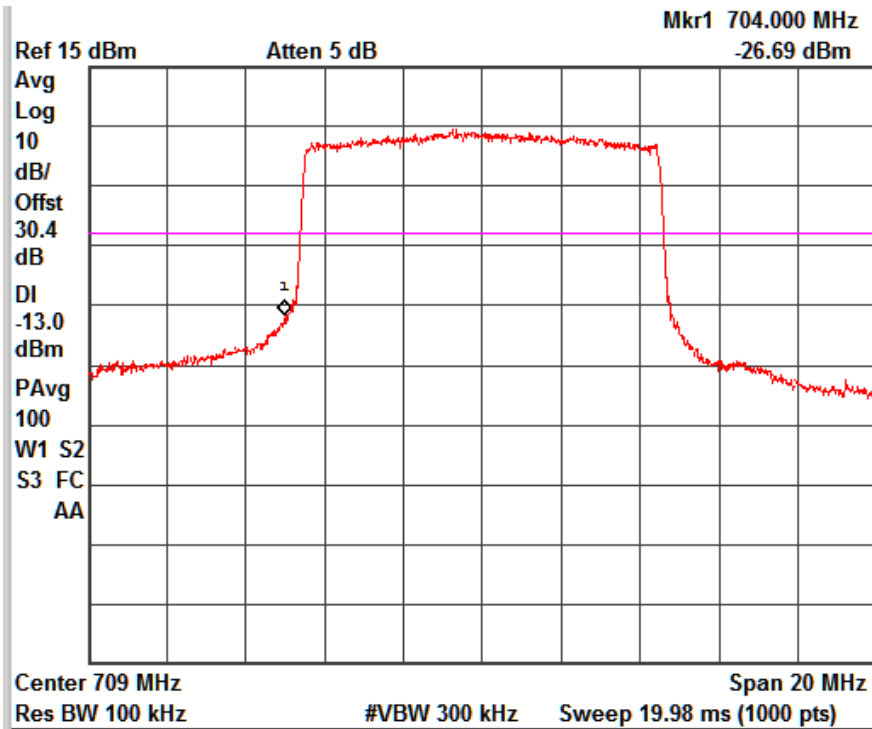
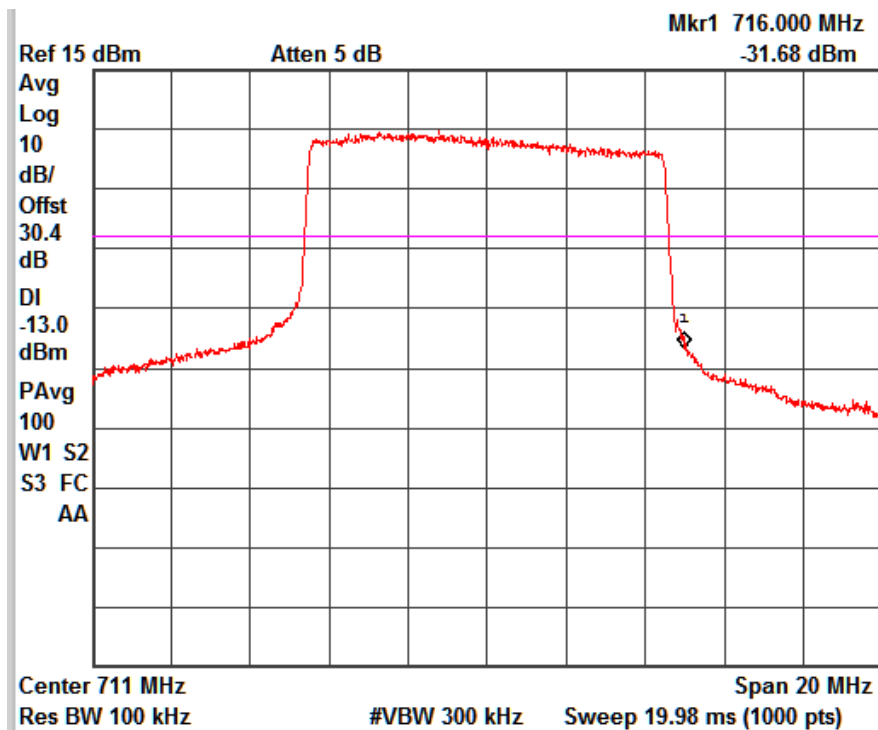
FDD Band 17_Channel Low_10MHz

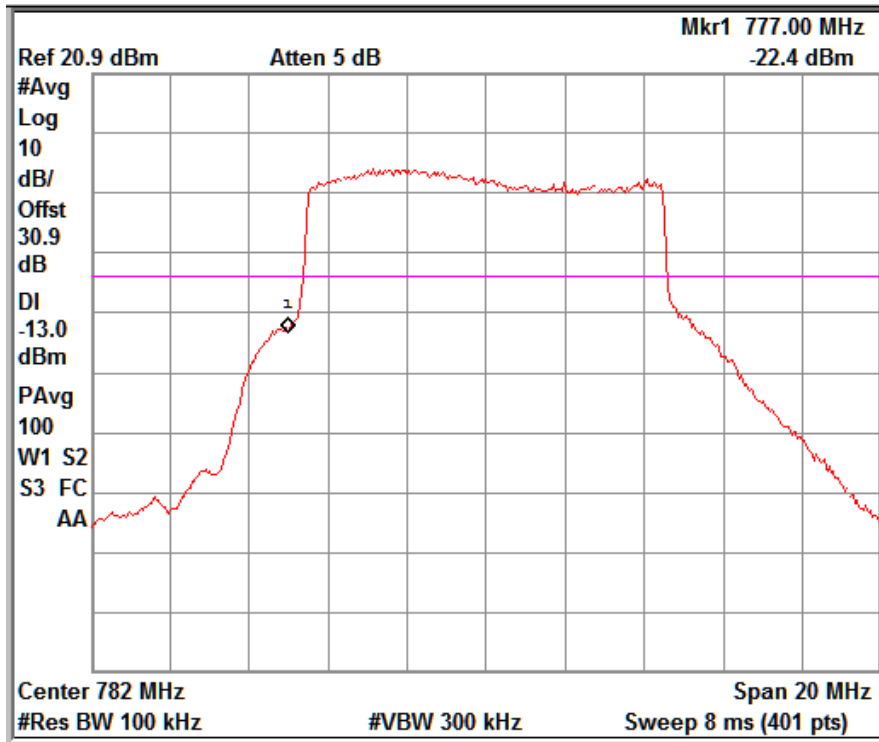
FDD Band 17_Channel High_10MHz

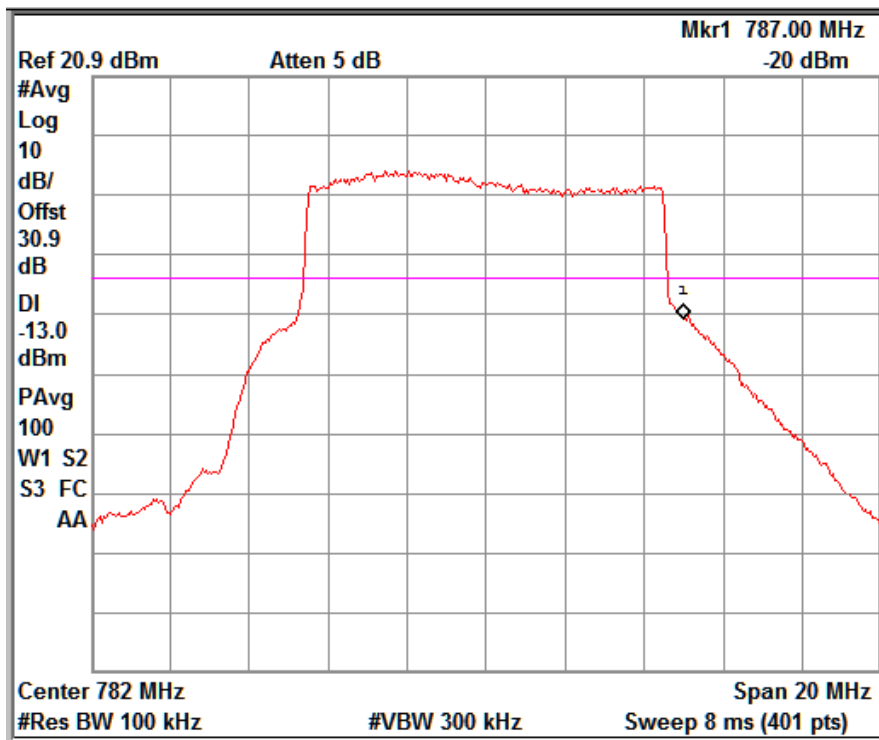

FDD Band 13_Channel Mid_10MHz



FDD Band 13_Channel Mid_10MHz

Modulation: 16QAM						
FDD Band	Bandwidth	Channel	Channel Frequency (MHz)	Band edge Frequency Range (MHz)	Band Edge Value (dBm)	Limit (dBm)
2	5	Low	1852.5	1849-1850	-25.00	-13
		High	1907.5	1910-1911	-24.40	-13
	10	Low	1860	1849-1850	-37.74	-13
		High	1905	1910-1911	-20.30	-13
	15	Low	1857.5	1849-1850	-37.33	-13
		High	1902.5	1910-1911	-36.99	-13
	20	Low	1860	1849-1850	-34.38	-13
		High	1900	1910-1911	-31.22	-13
4	5	Low	1712.5	1709-1710	-23.91	-13
		High	1752.5	1755-1756	-26.17	-13
	10	Low	1715	1709-1710	-19.43	-13
		High	1750	1755-1756	-19.14	-13
	15	Low	1717.5	1709-1710	-35.78	-13
		High	1747.5	1755-1756	-36.99	-13
	20	Low	1720	1709-1710	-31.73	-13
		High	1745	1755-1756	-30.98	-13
5	5	Low	826.5	823-824	-23.88	-13
		High	846.5	849-850	-25.46	-13
	10	Low	829	823-824	-25.30	-13
		High	844	849-850	-36.54	-13
17	5	Low	706.5	703-704	-23.91	-13
		High	713.5	716-717	-25.87	-13
	10	Low	709	703-704	-29.53	-13
		High	711	716-717	-32.12	-13
13	10	Mid	782	776-777	-24.83	-13
		Mid	782	787-789	-23.18	-13

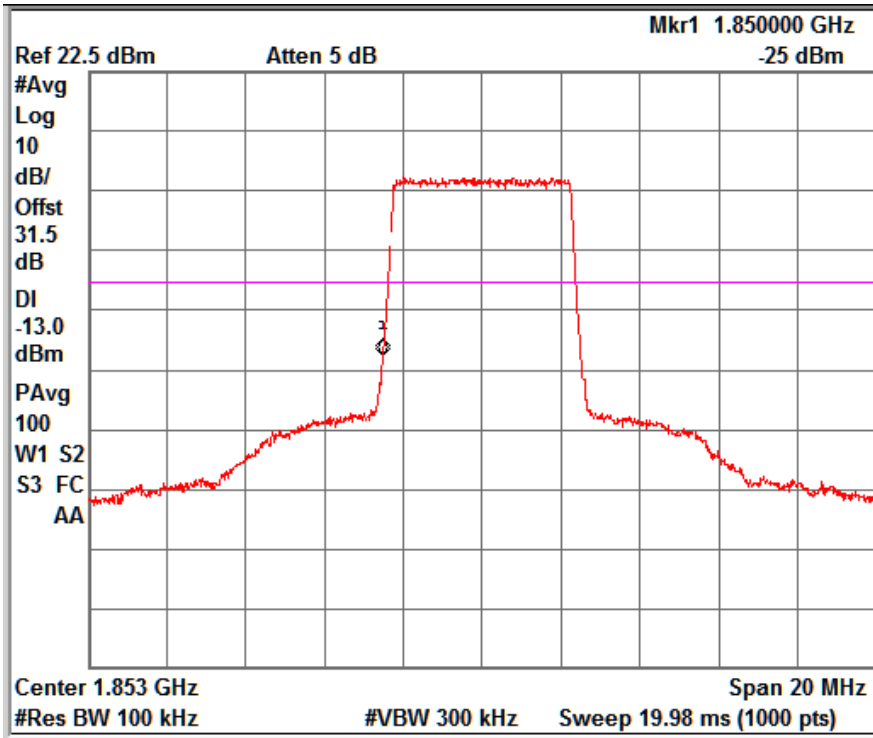
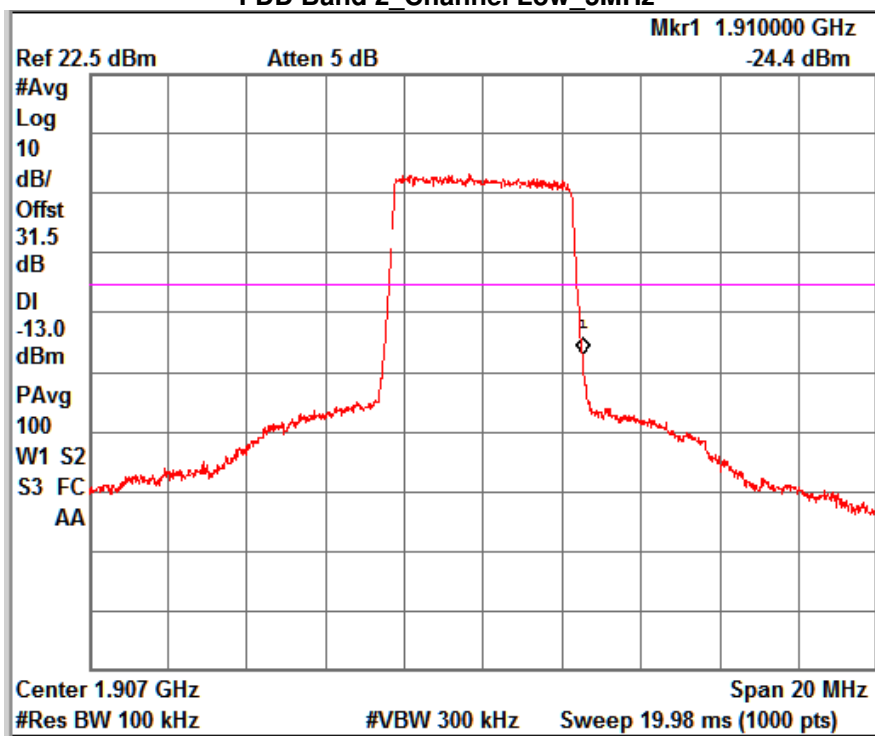

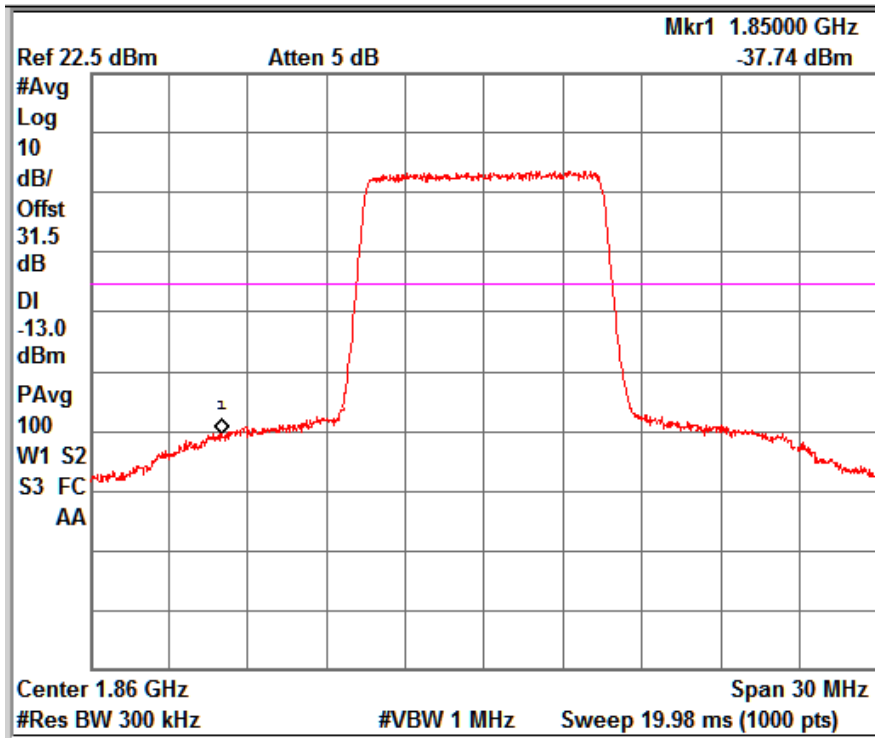
FDD Band 2_Channel Low_5MHz

FDD Band 2_Channel High_5MHz

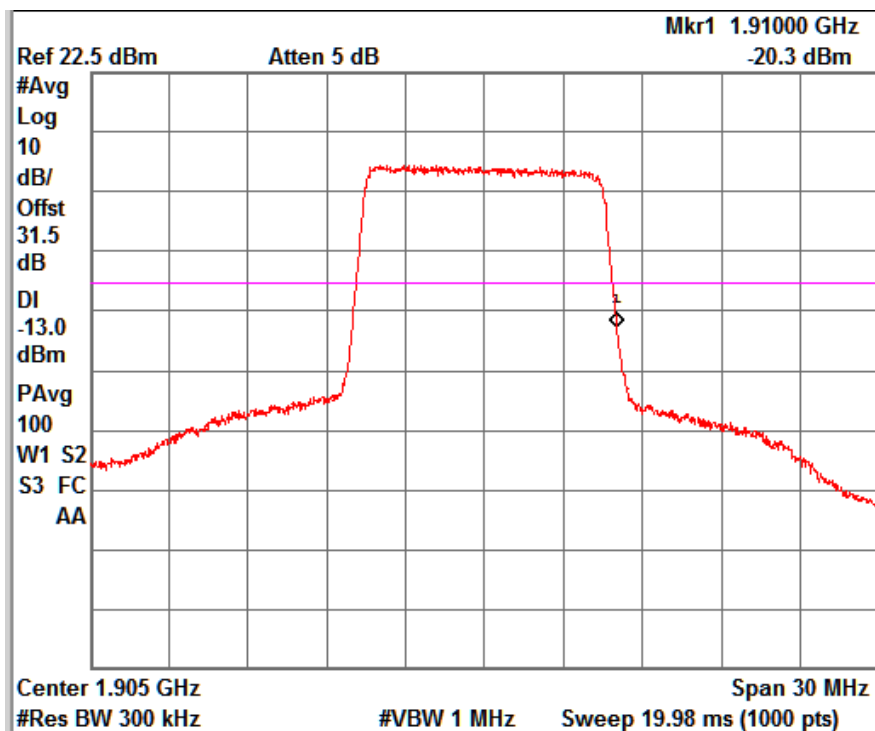

FDD Band 2_Channel Low_10MHz

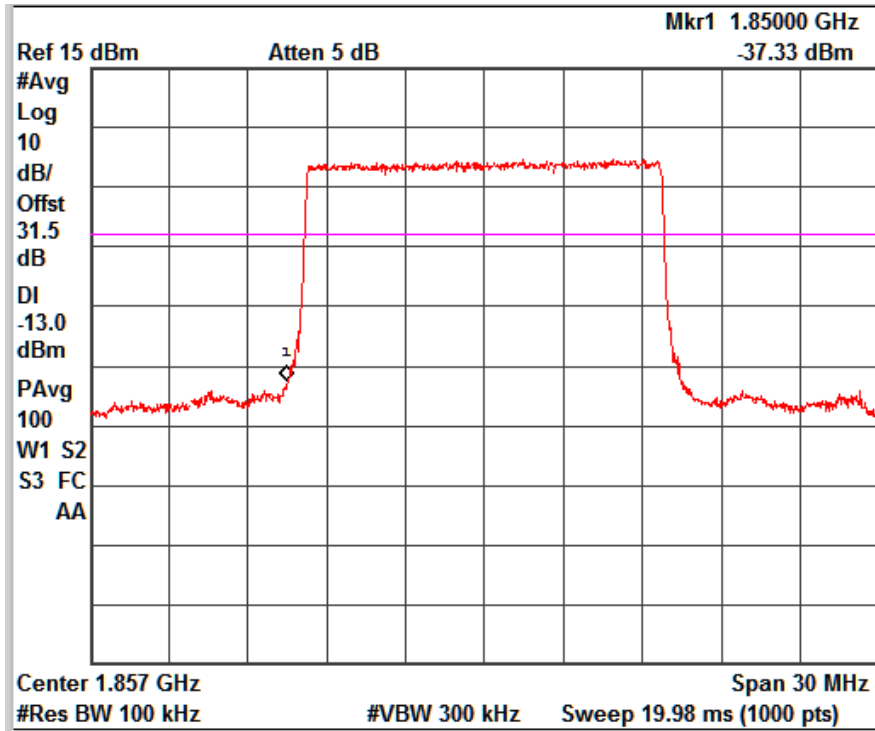

FDD Band 2_Channel High_10MHz



FDD Band 2_Channel Low_15MHz

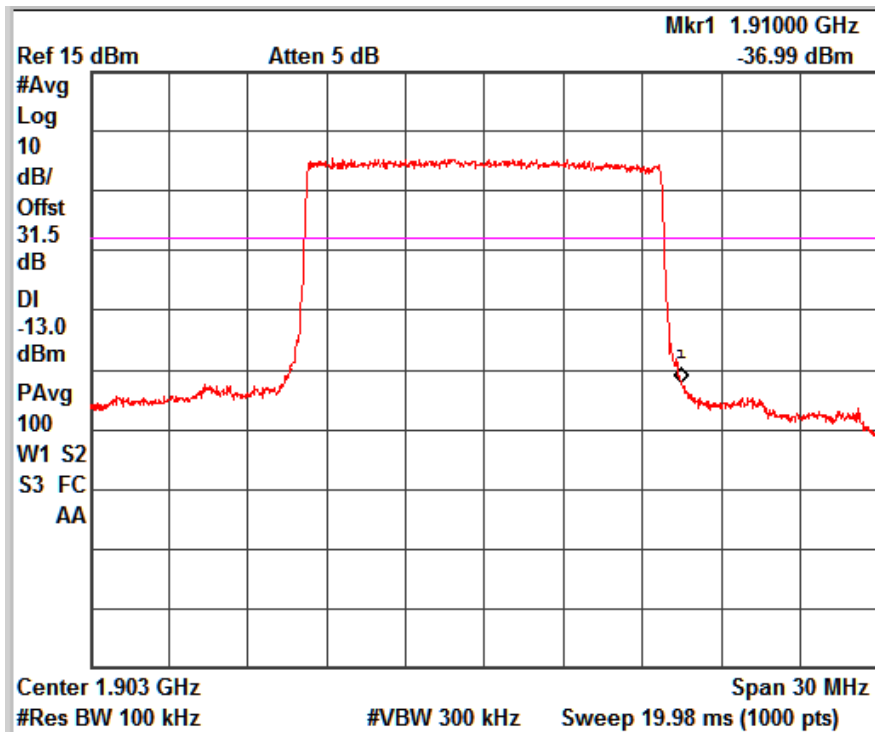

FDD Band 2_Channel High_15MHz

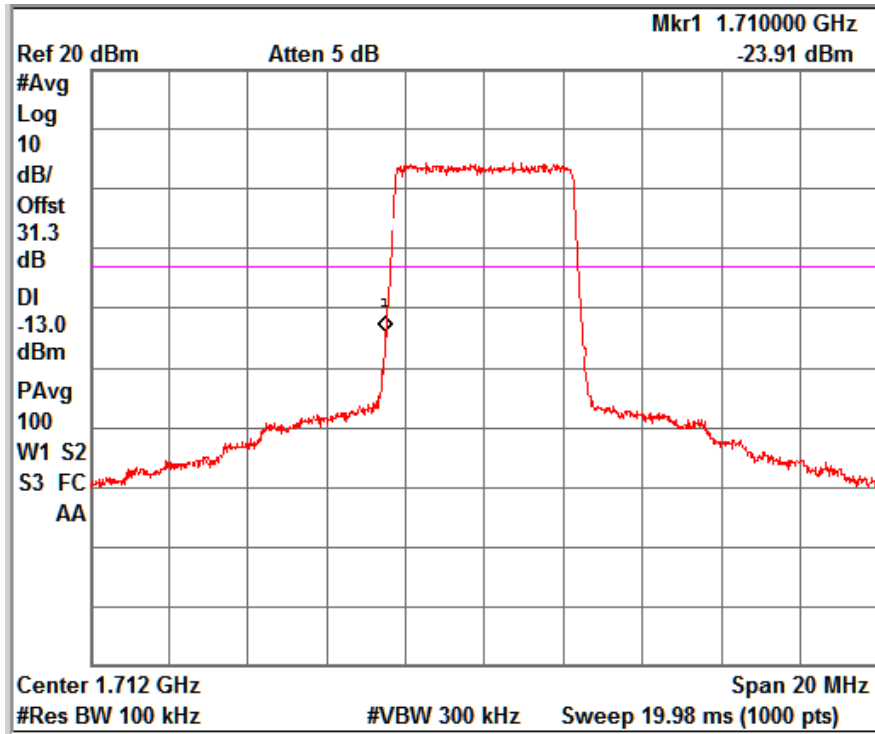
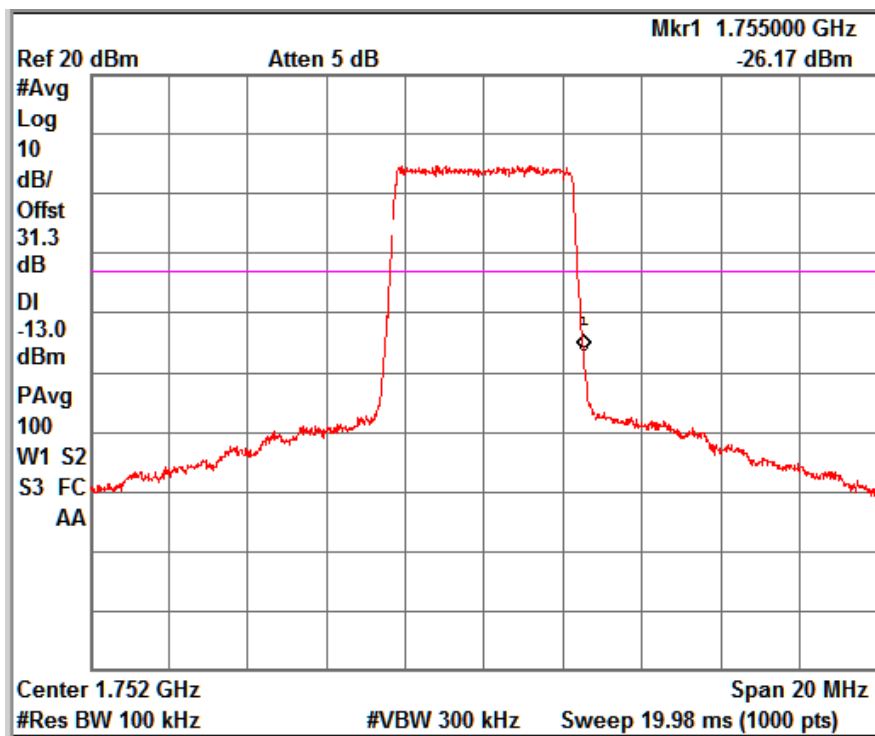

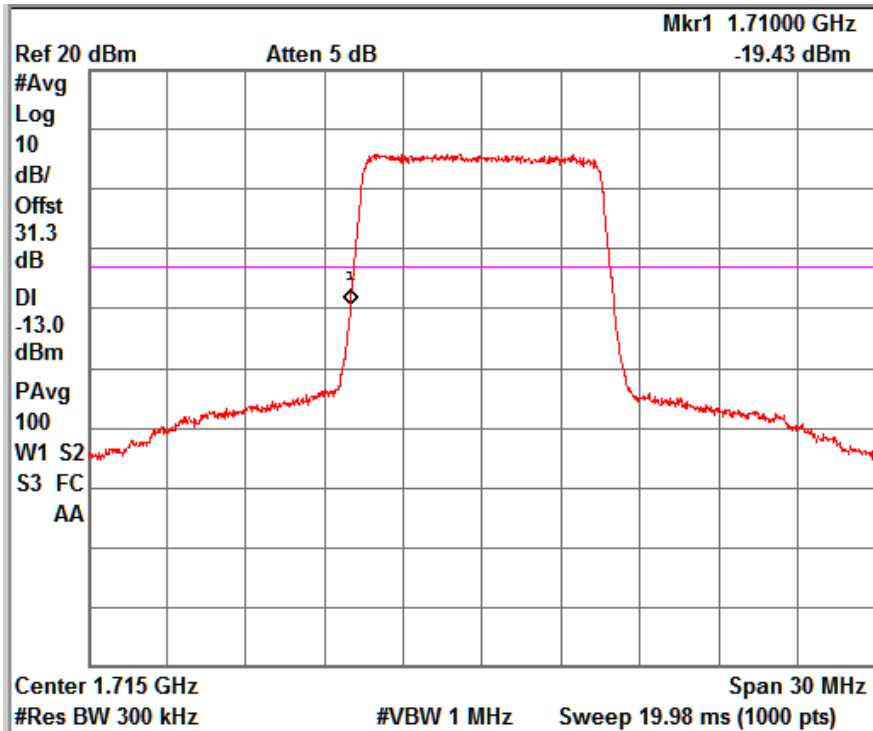
FDD Band 4_Channel Low_5MHz

FDD Band 4_Channel High_5MHz

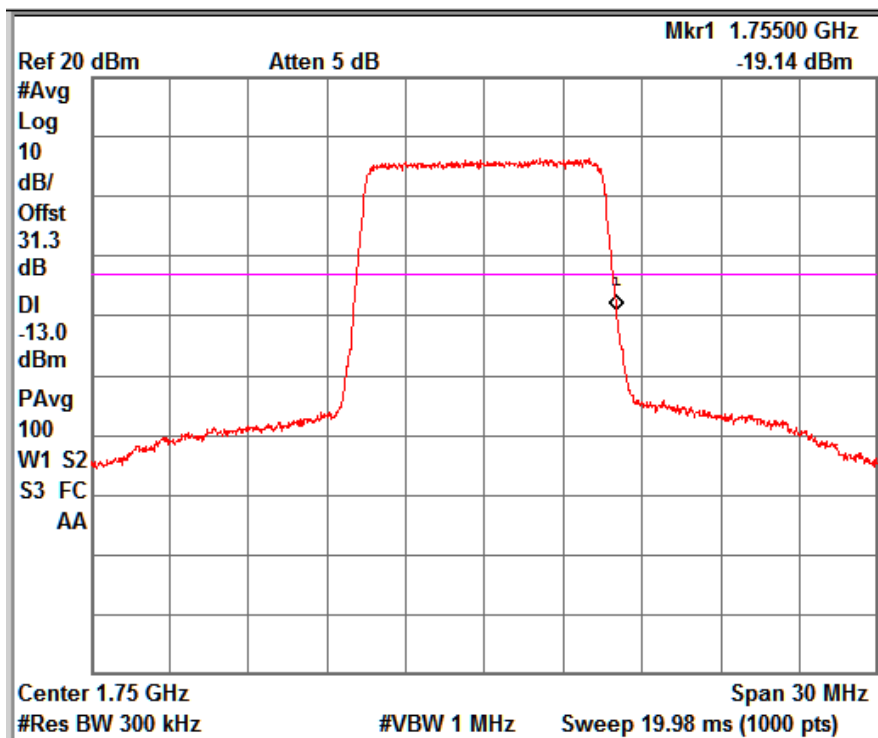

FDD Band 4_Channel Low_10MHz

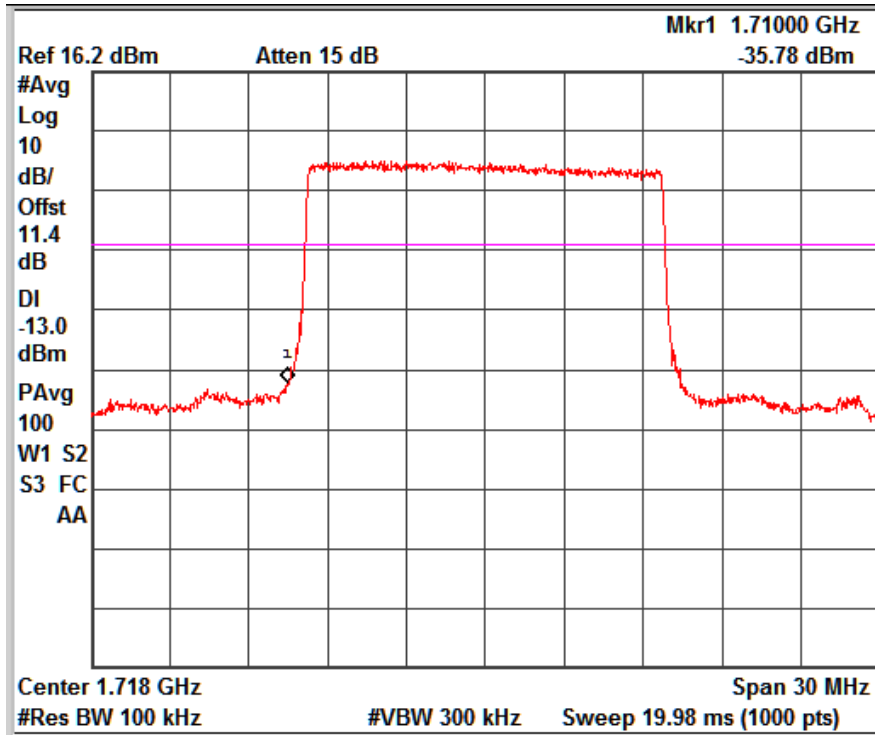

FDD Band4_Channel High_10MHz



FDD Band4_Channel Low_15MHz

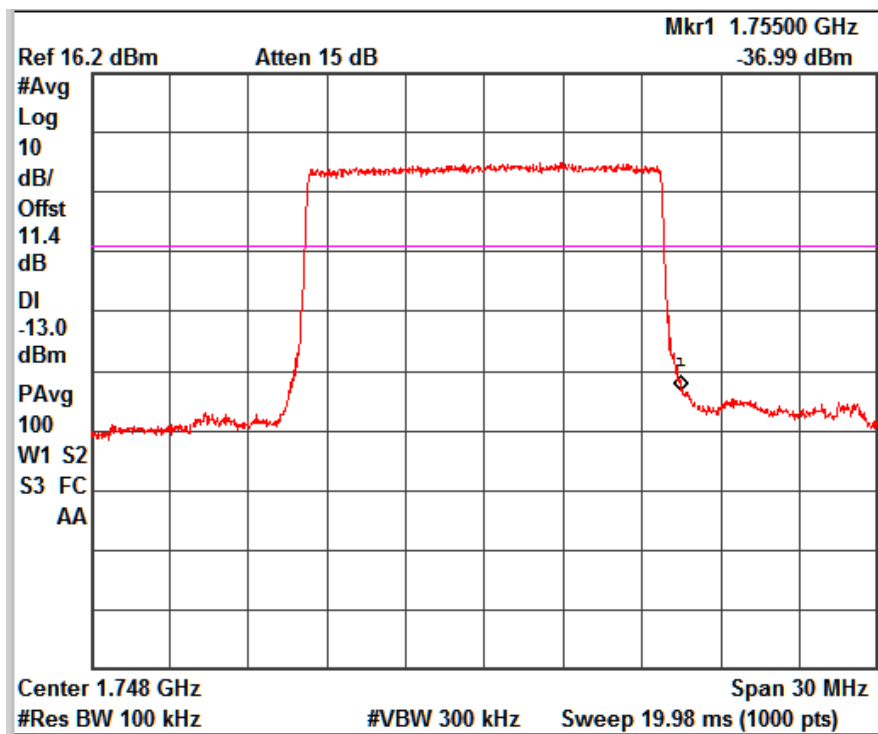

FDD Band4_Channel High_15MHz

www.tuv.com

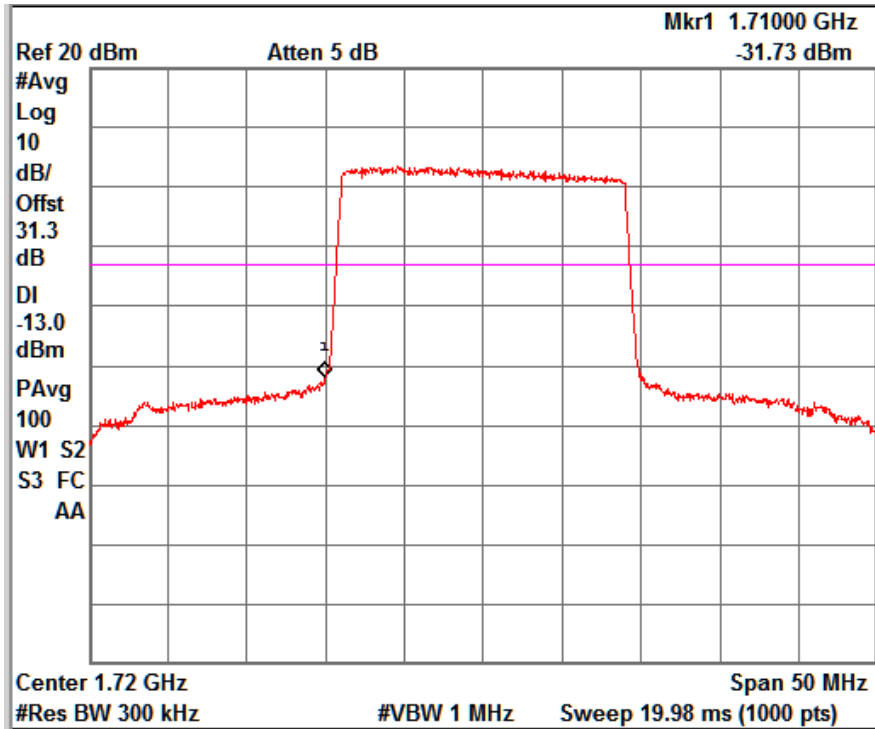

FDD Band 4_Channel Low_20MHz

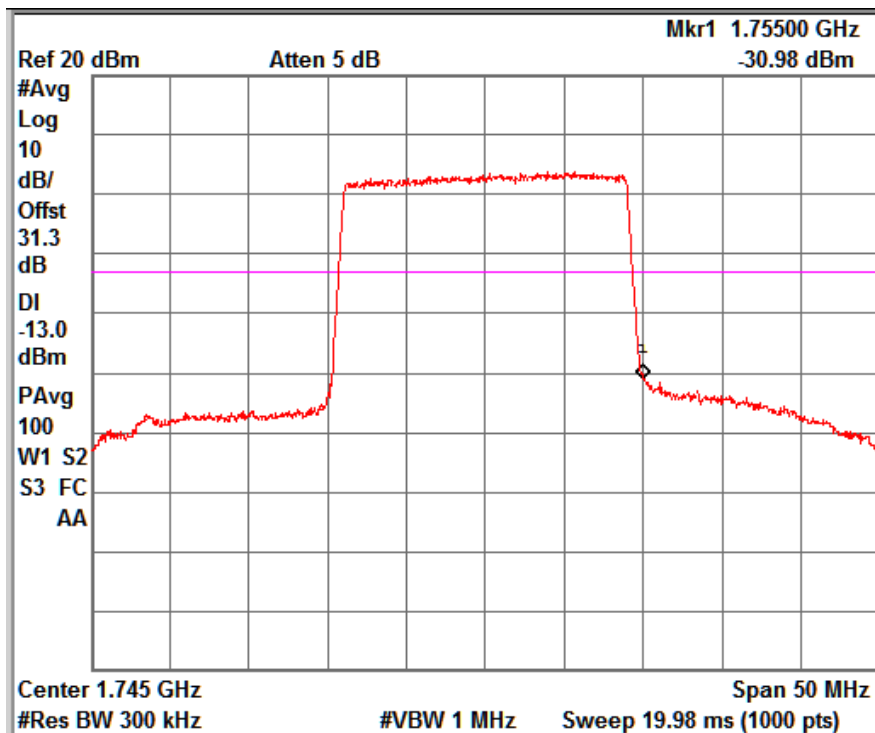

FDD Band 4_Channel High_20MHz

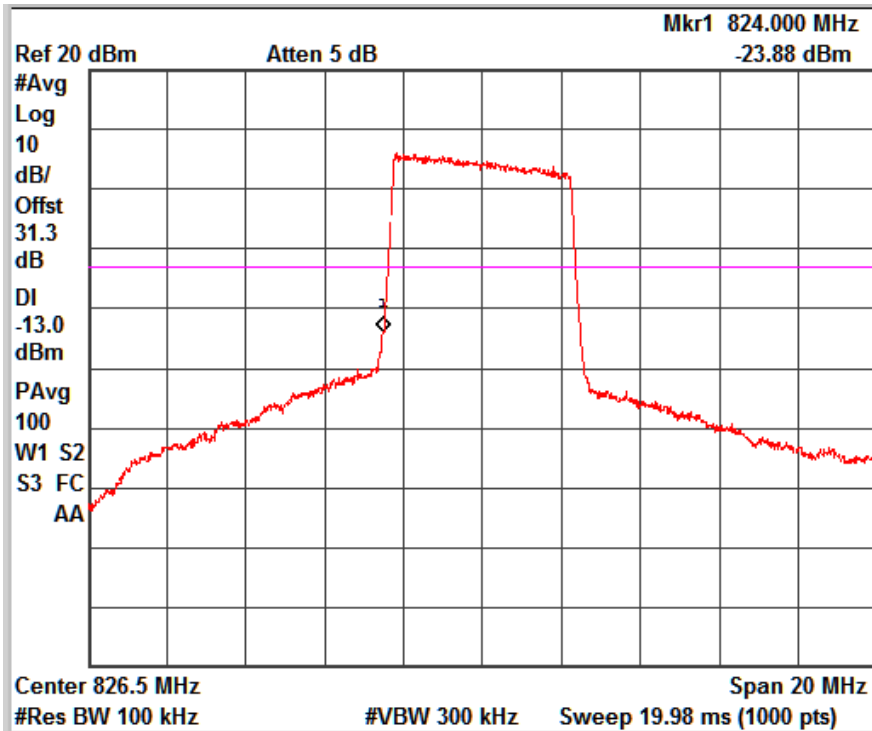
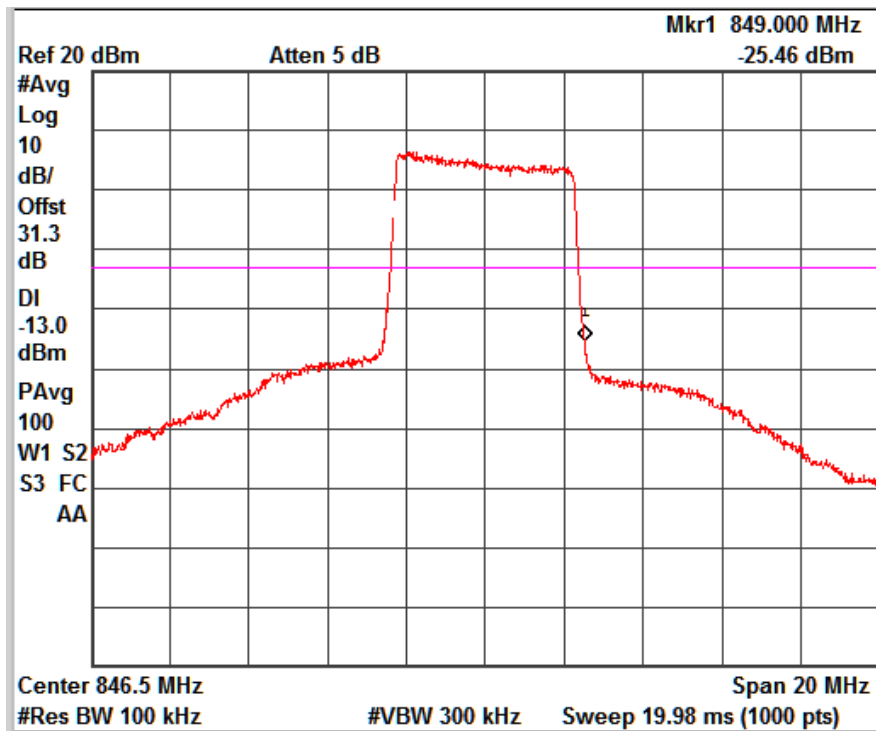
FDD Band 5_Channel Low_5MHz

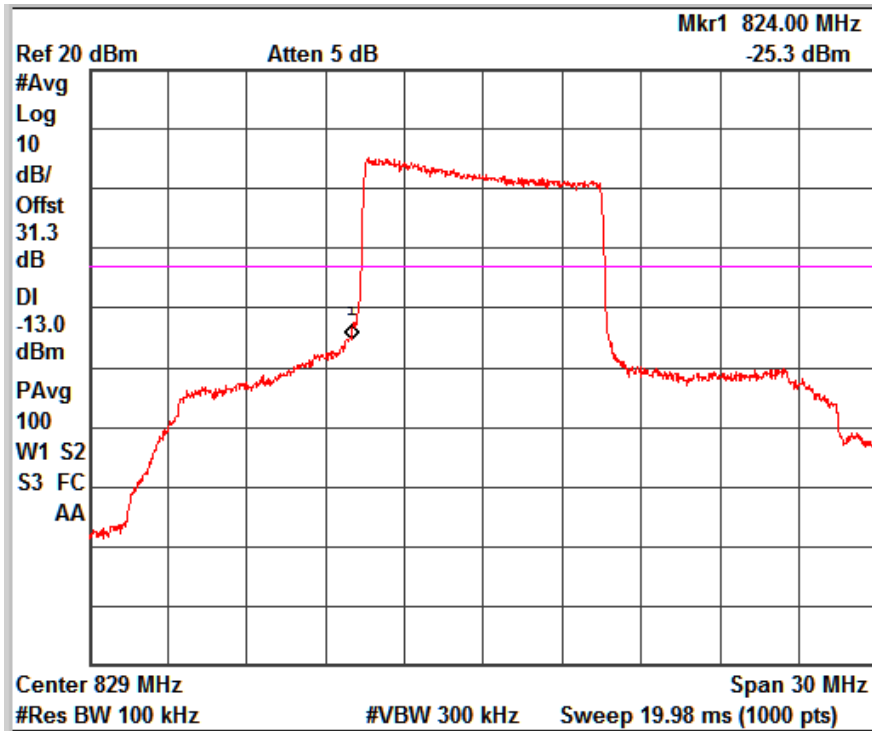
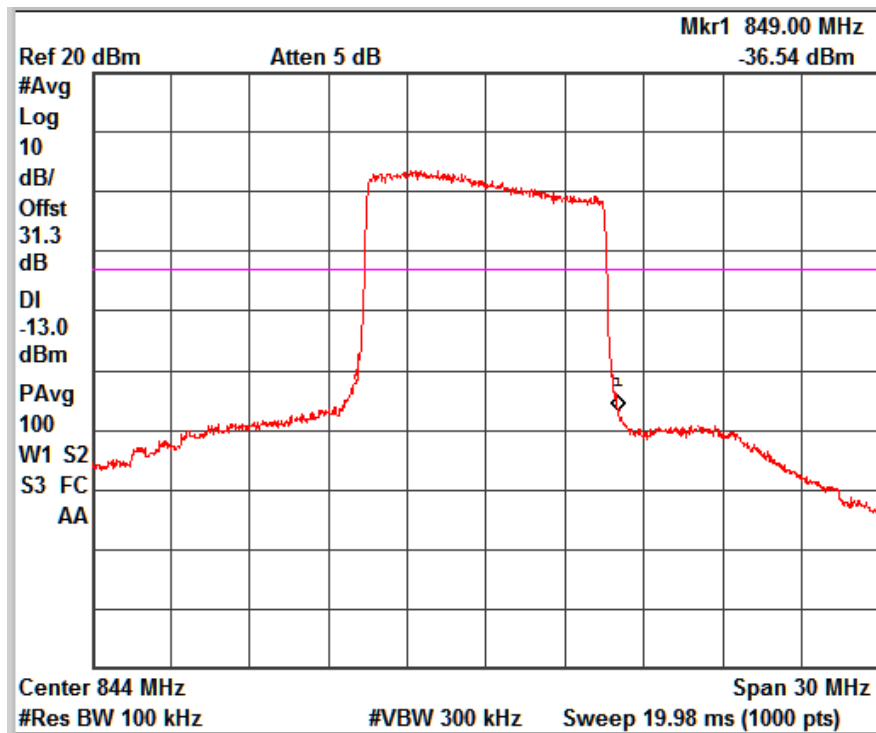
FDD Band 5_Channel High_5MHz

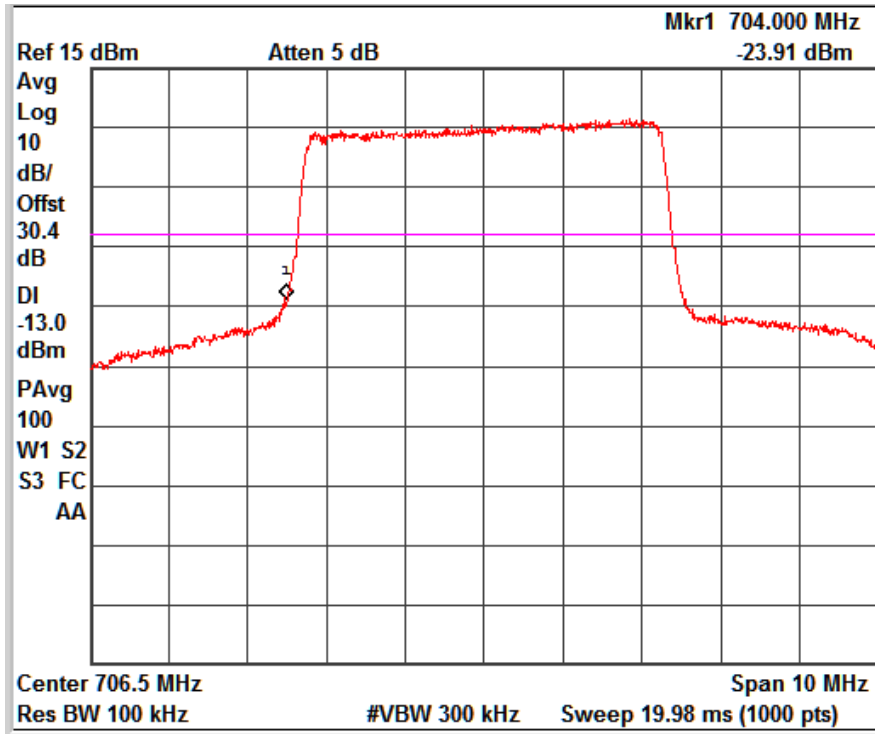
FDD Band 5_Channel Low_10MHz

FDD Band 5_Channel High_10MHz

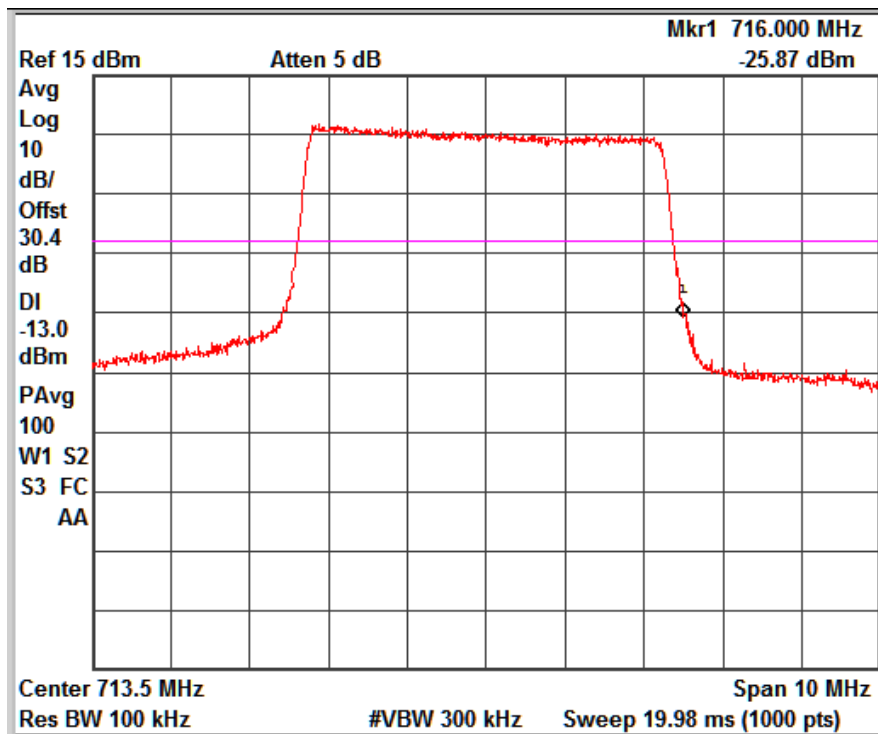

FDD Band 17_Channel Low_5MHz



FDD Band 17_Channel High_5MHz

www.tuv.com

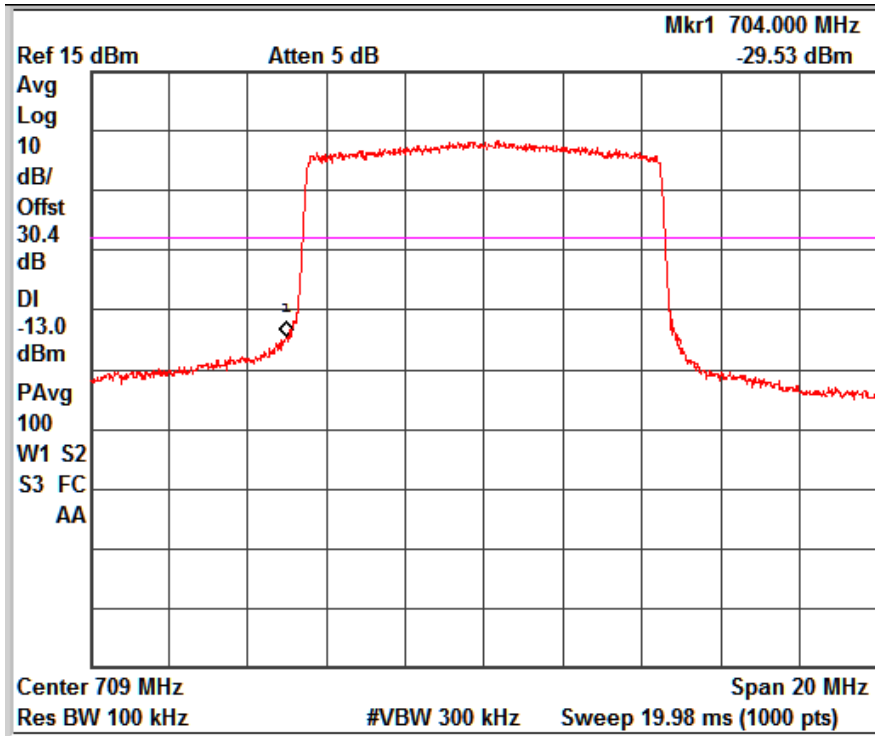

FDD Band 17_Channel Low_10MHz

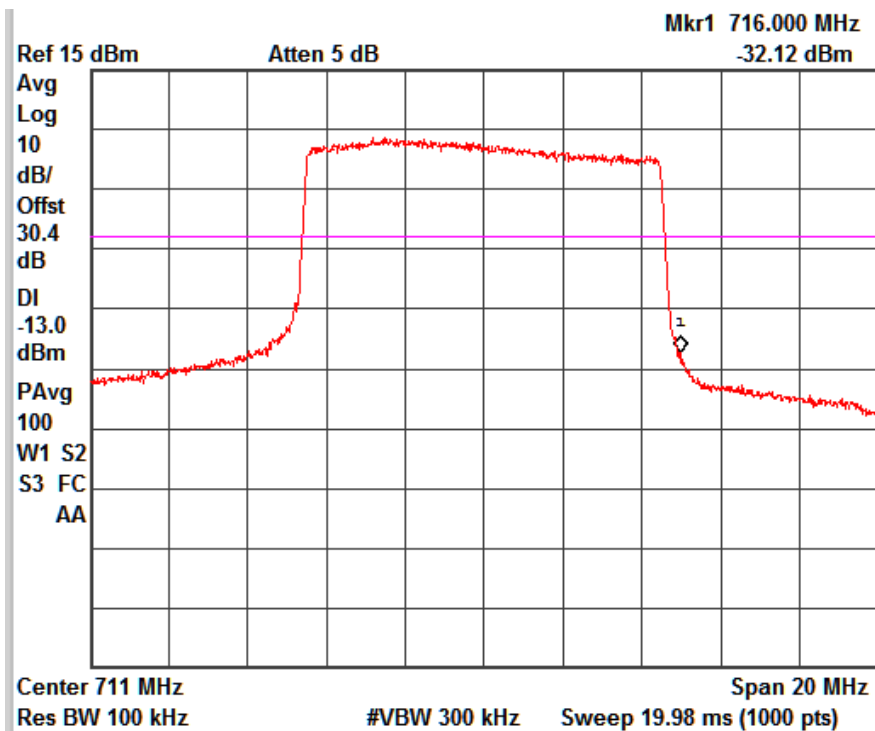

FDD Band 17_Channel High_10MHz

www.tuv.com

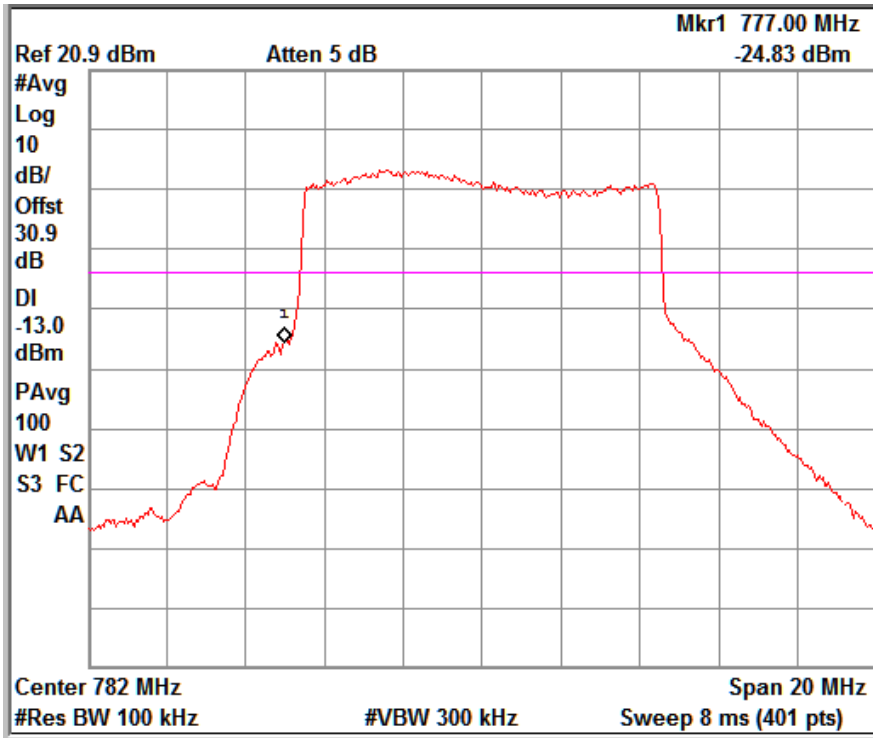

FDD Band 13_Channel Mid_10MHz

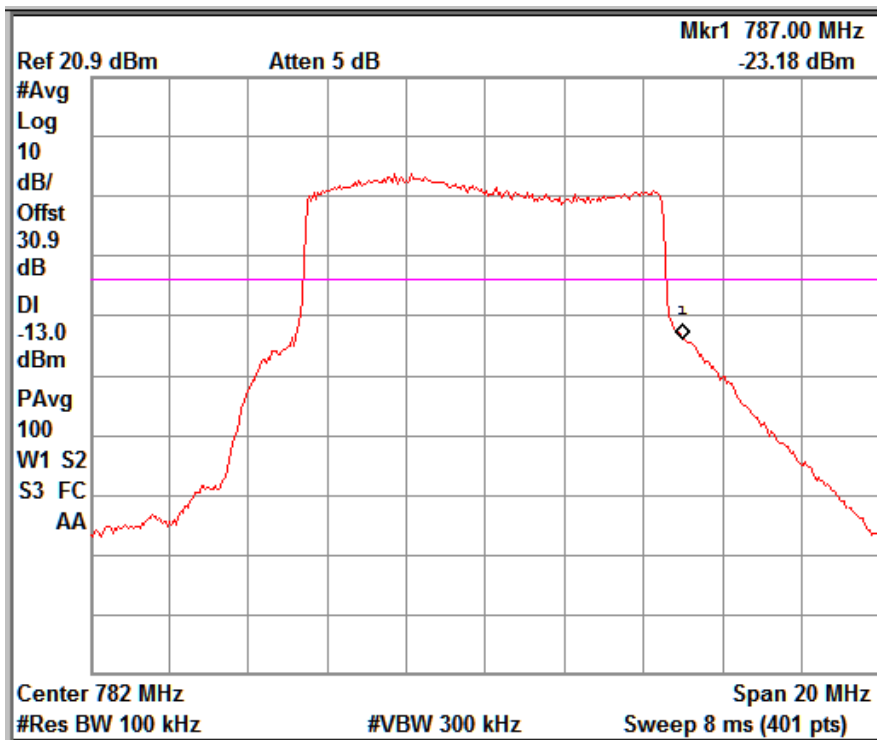

FDD Band 13_Channel Mid_10MHz

www.tuv.com

Conducted Spurious Emission Result

Pass

Specification	FCC Part 2.1051, 2.1057, 22.917(a)(b), 24.238(a)(b), 27.53(h) & RSS 132 Issue 3 section 5.5, RSS 133 Issue 6 section 6.5 (i)(ii), RSS 139 Issue 3 section 6.6(i)(ii), RSS 130 Issue 1 section 4.6
Measurement Bandwidth (RBW)	100KHz/1MHz
Detector Function	Peak
Requirement	Shall be attenuated below the transmitter power (P in watt) by at least $43+10\log(P)$ dBm,

Test Setup:

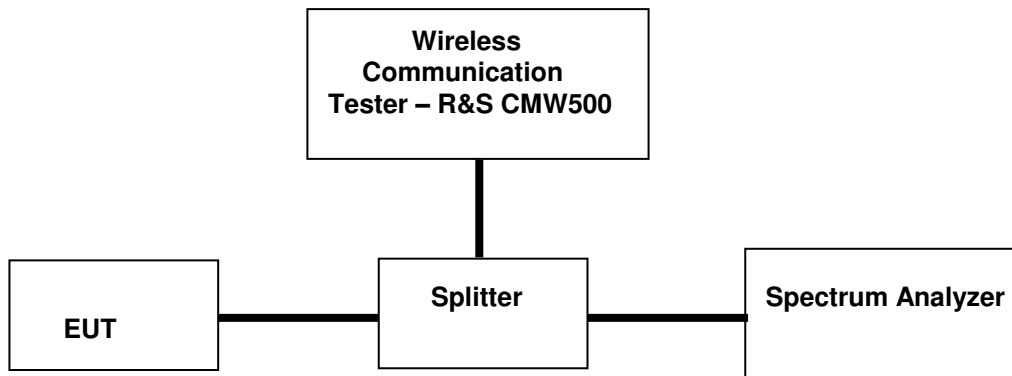

Note: For measurement of Conducted Spurious emission test, section 6.0 in “971168 D01 Power Meas License Digital Systems v02r02” was used.

Remark: Limit for antenna port conducted spurious emission test is -13dBm.

www.tuv.com
 Test Results:

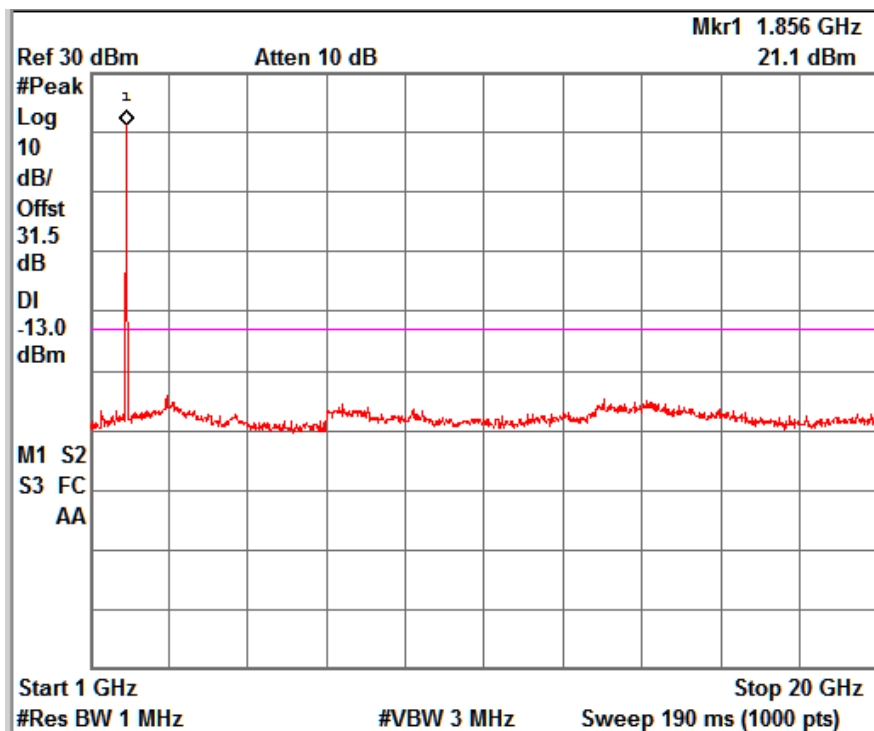
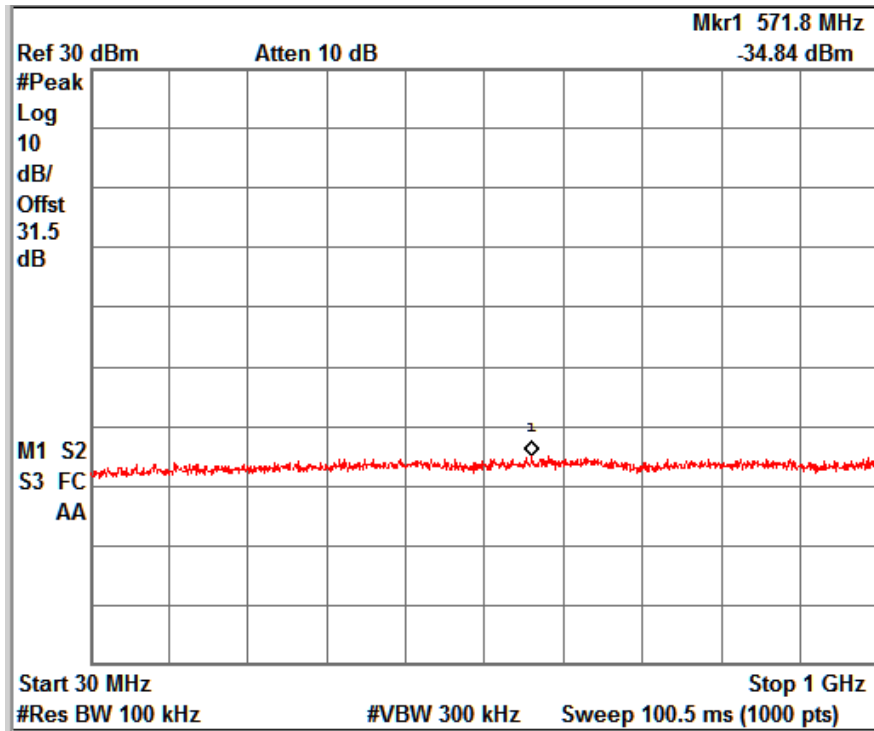

FDD Band 2_Channel Low_5MHz

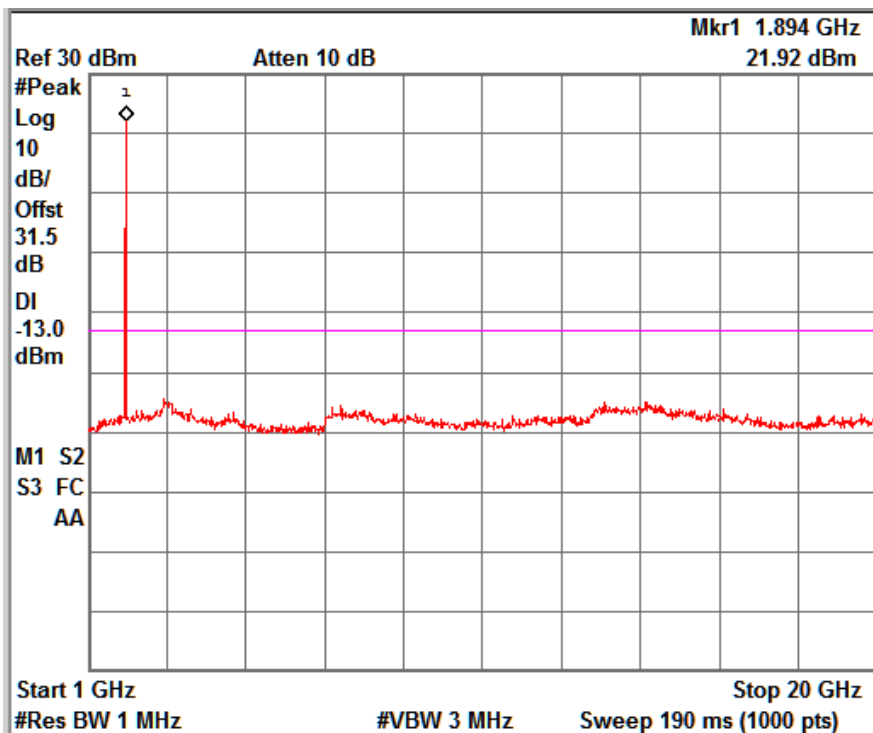
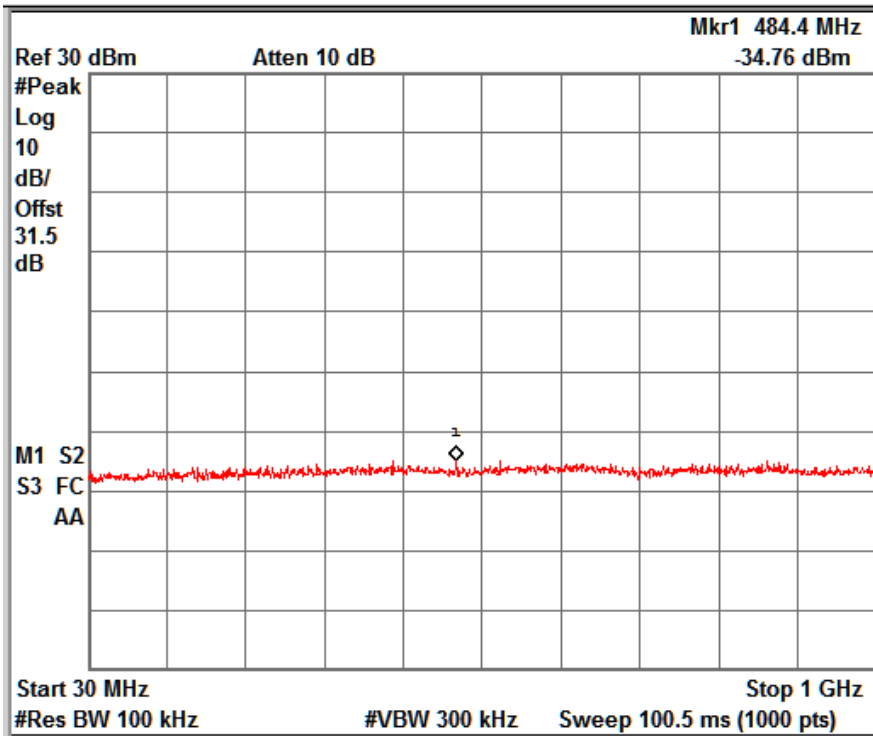

FDD Band 2_Channel Mid_5MHz

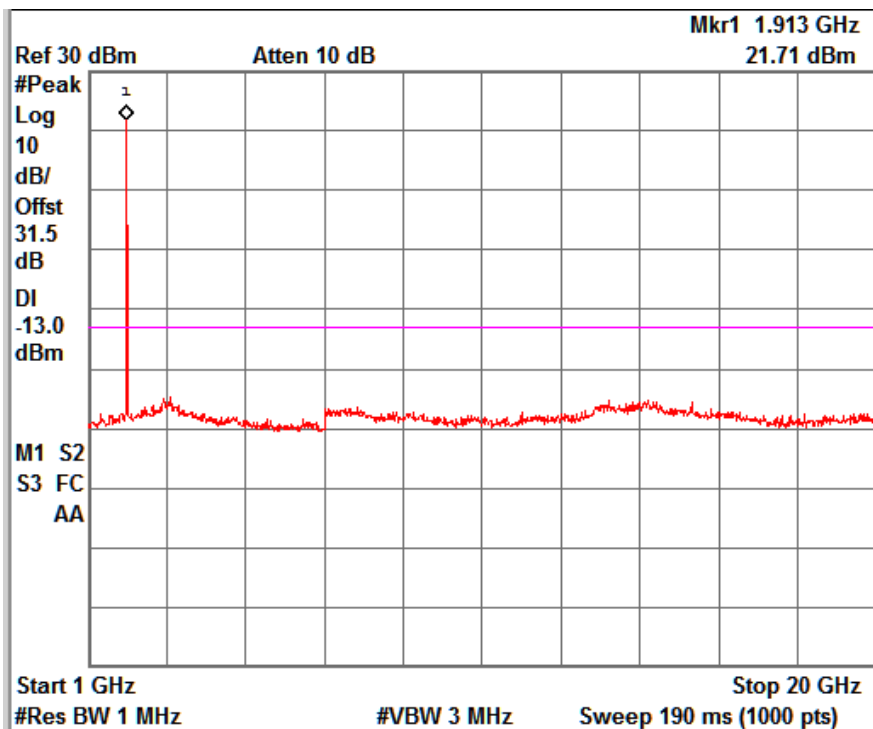
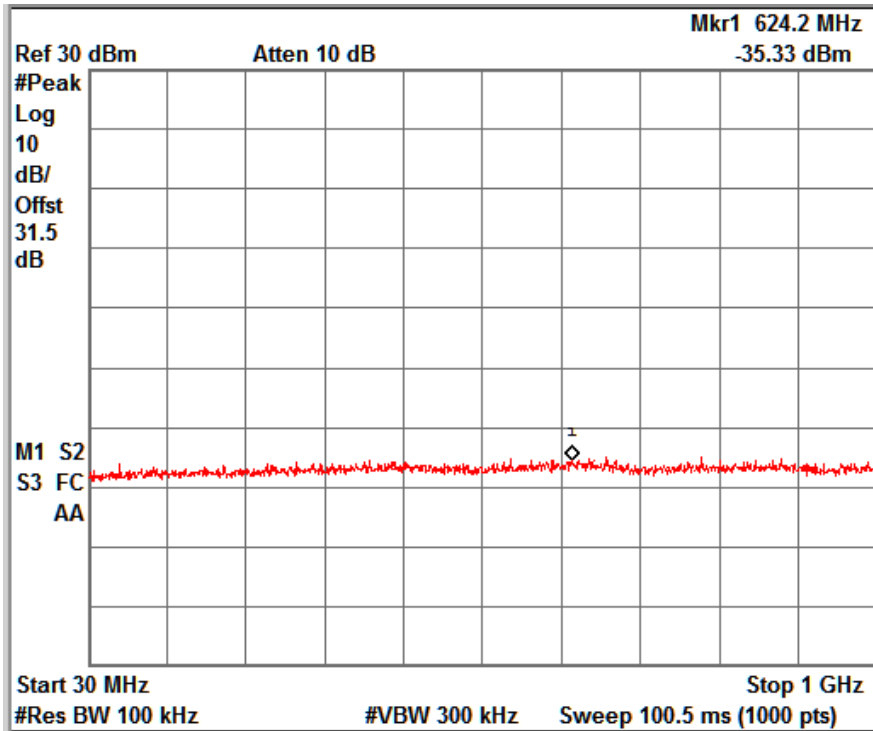

FDD Band 2_Channel High_5MHz

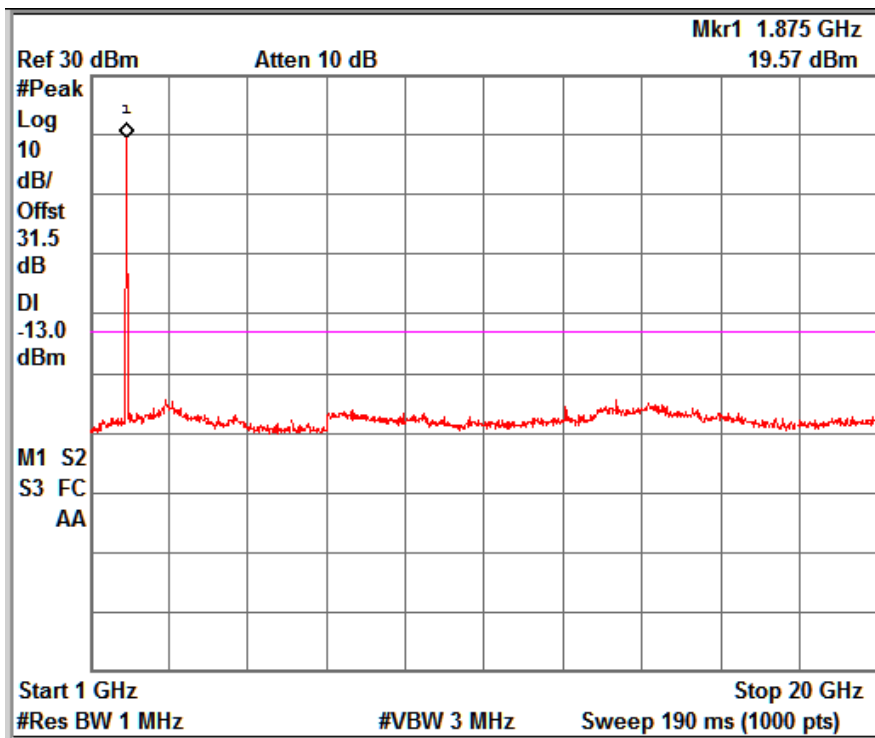
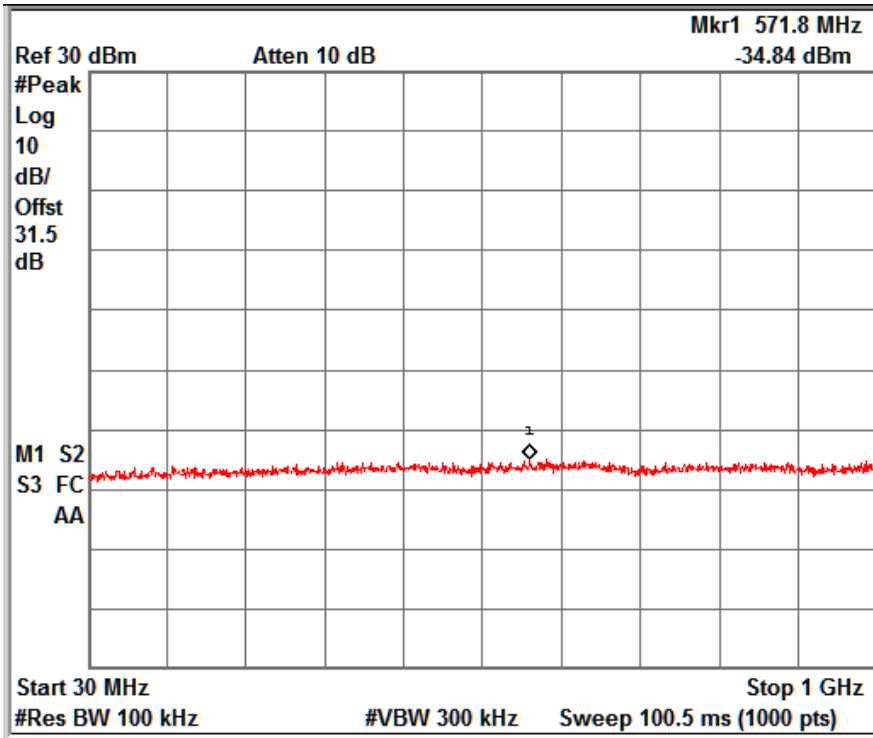

FDD Band 2_Channel Low_10MHz

www.tuv.com

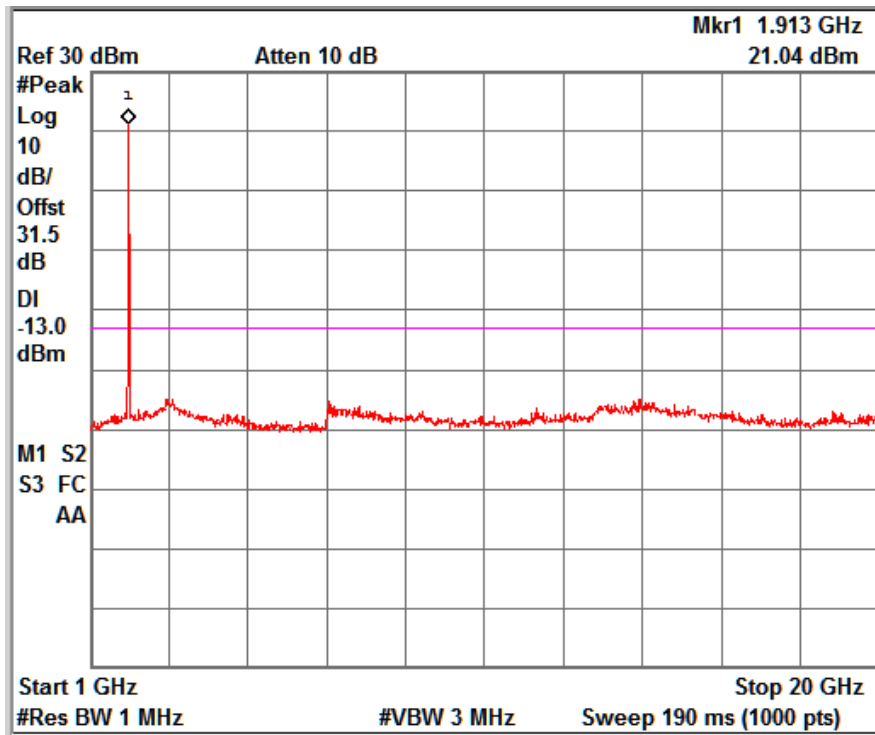
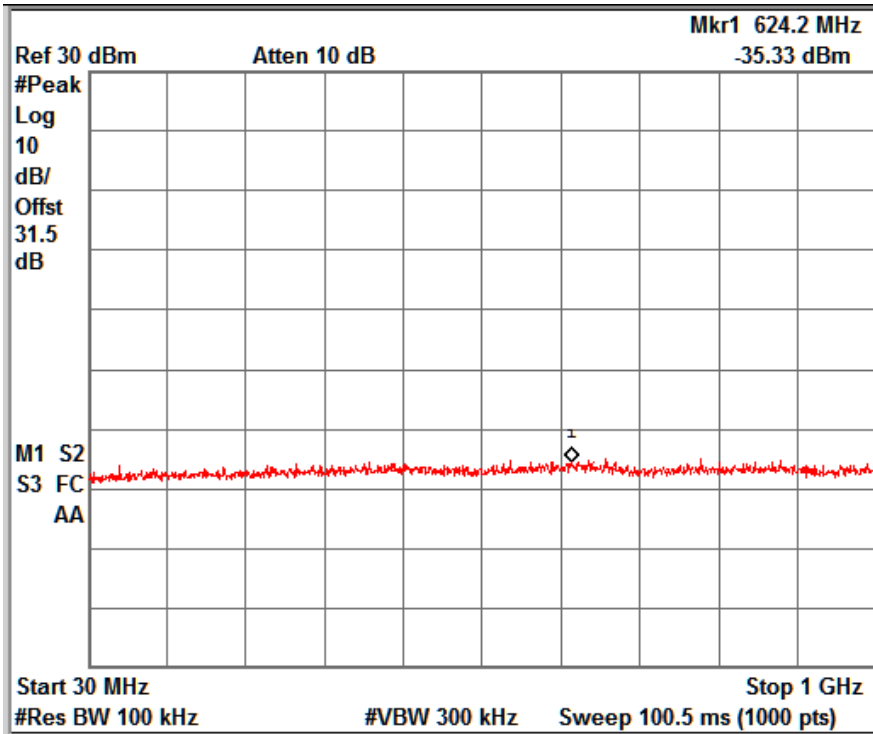

FDD Band 2_Channel High_10MHz

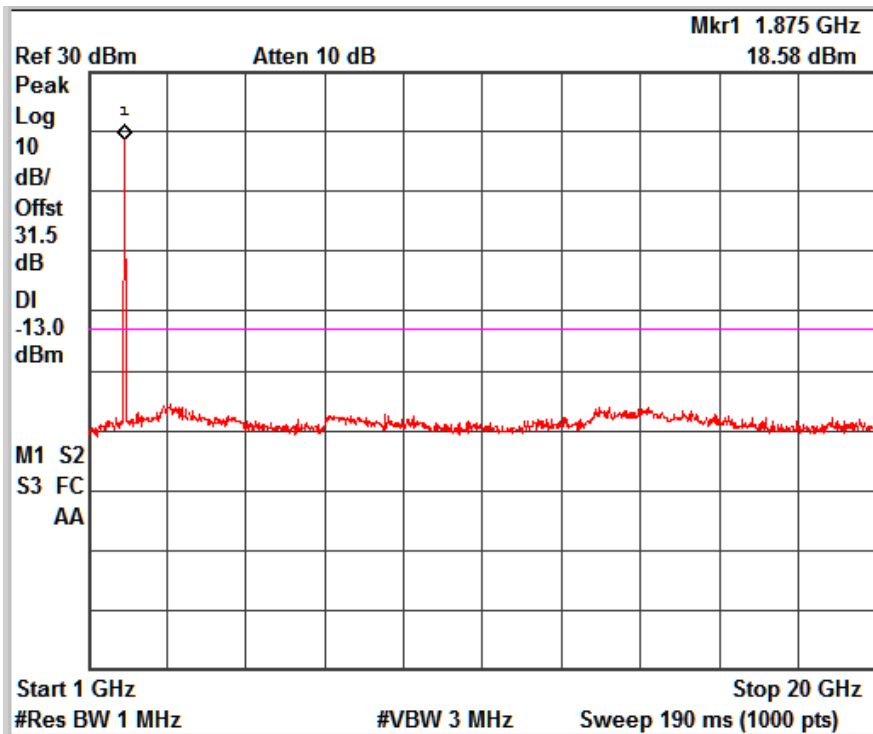
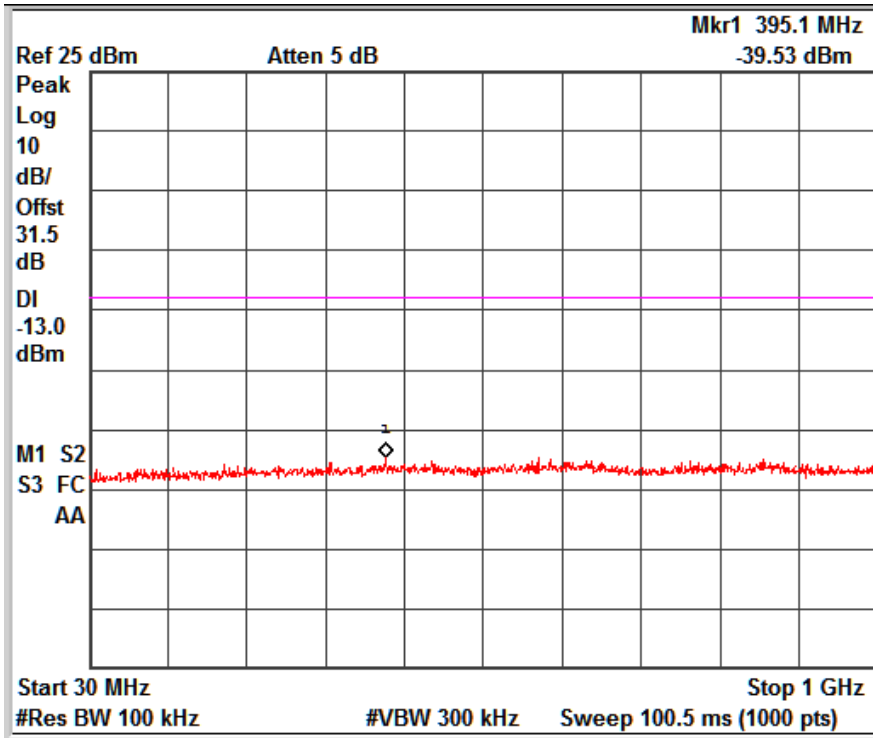

FDD Band 2_Channel Low_15MHz

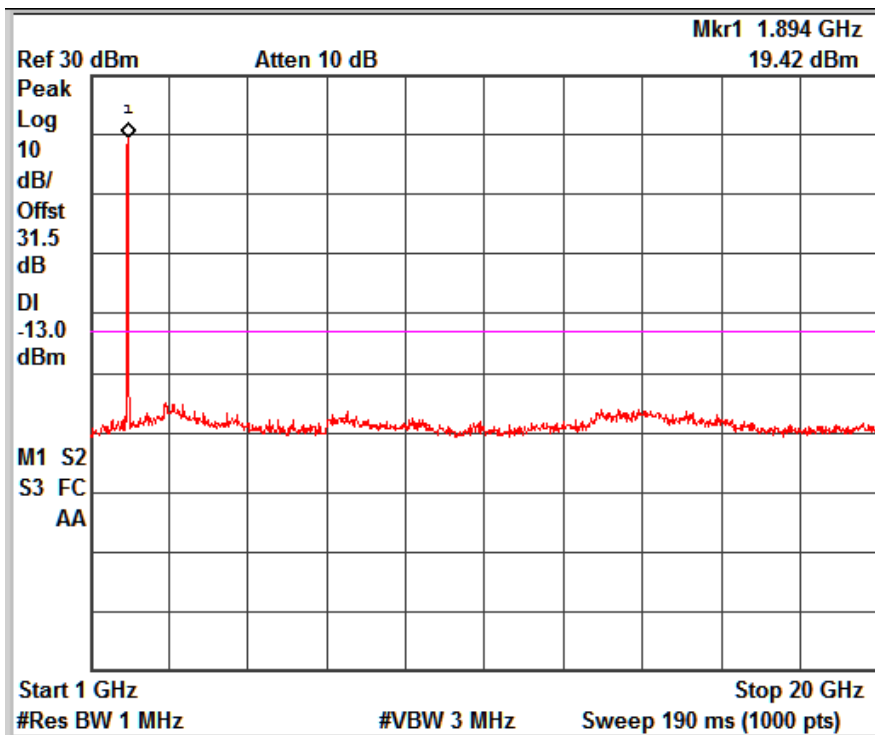
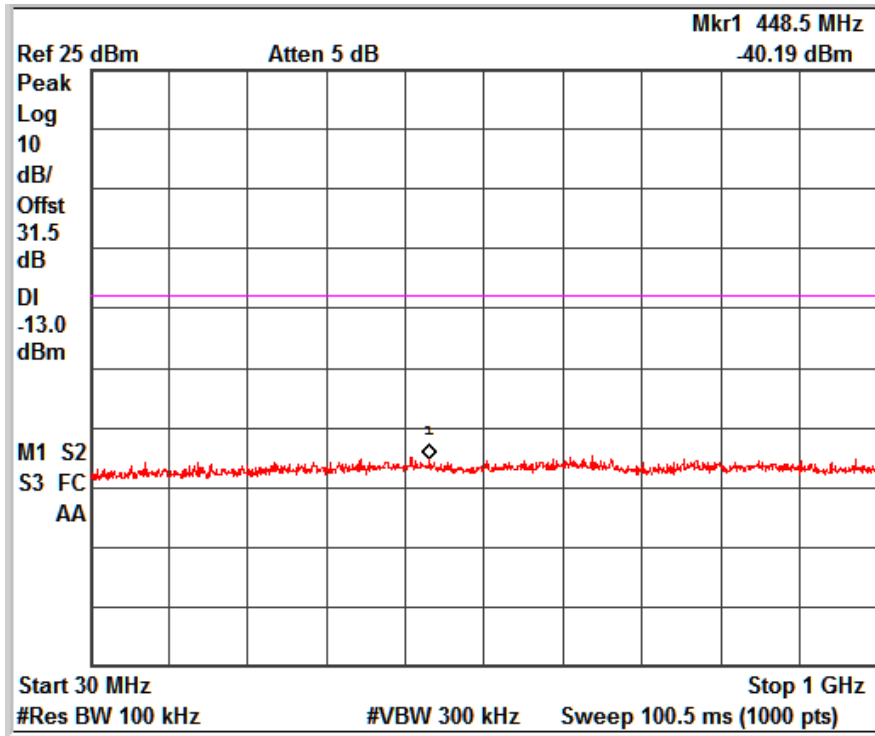

FDD Band 2_Channel Mid_15MHz

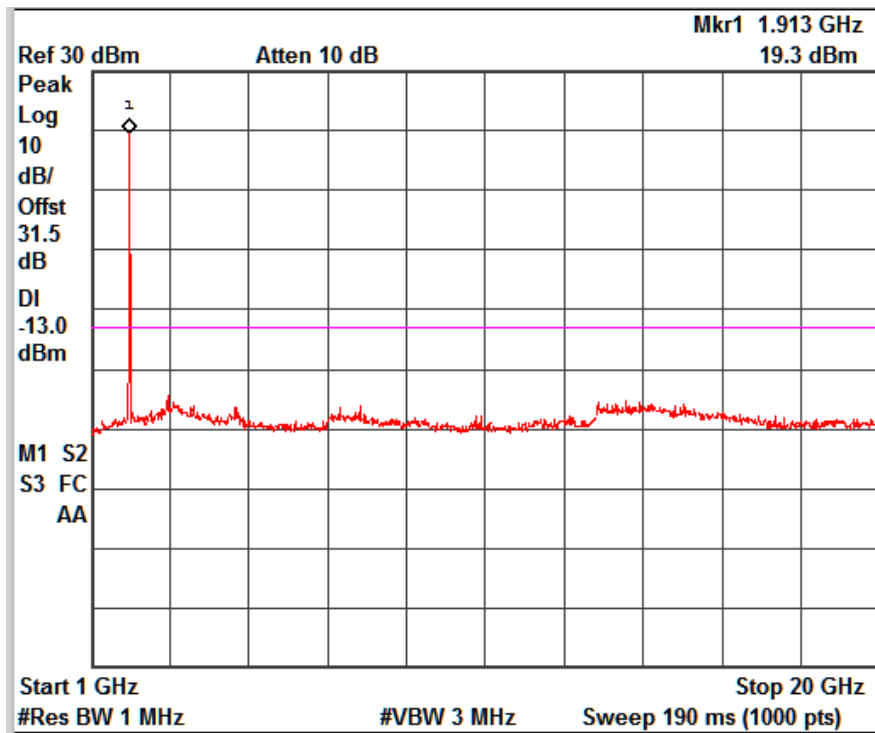
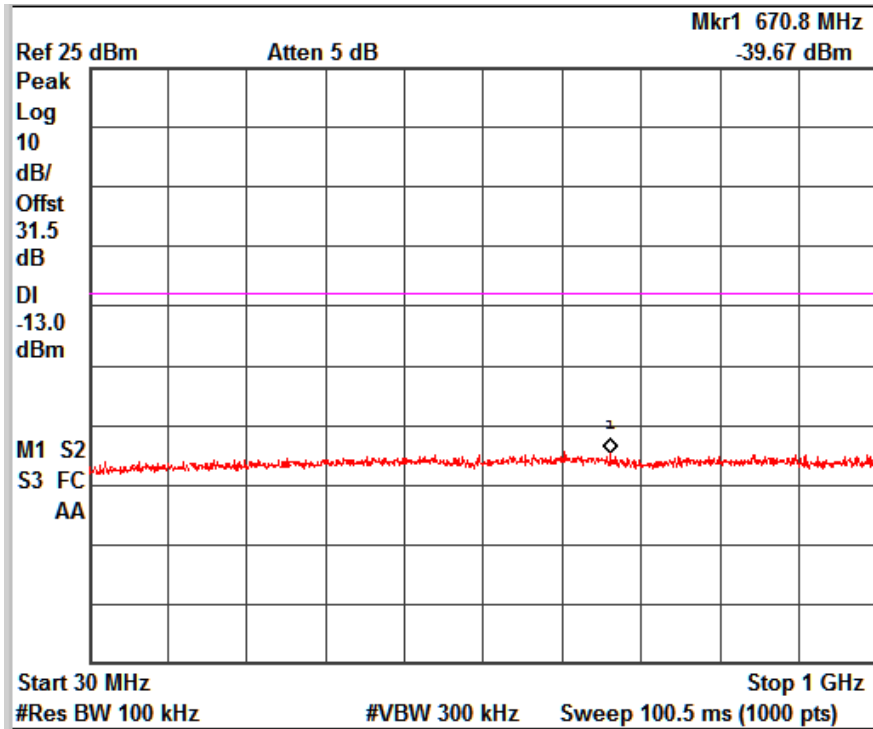

FDD Band 2_Channel High_15MHz

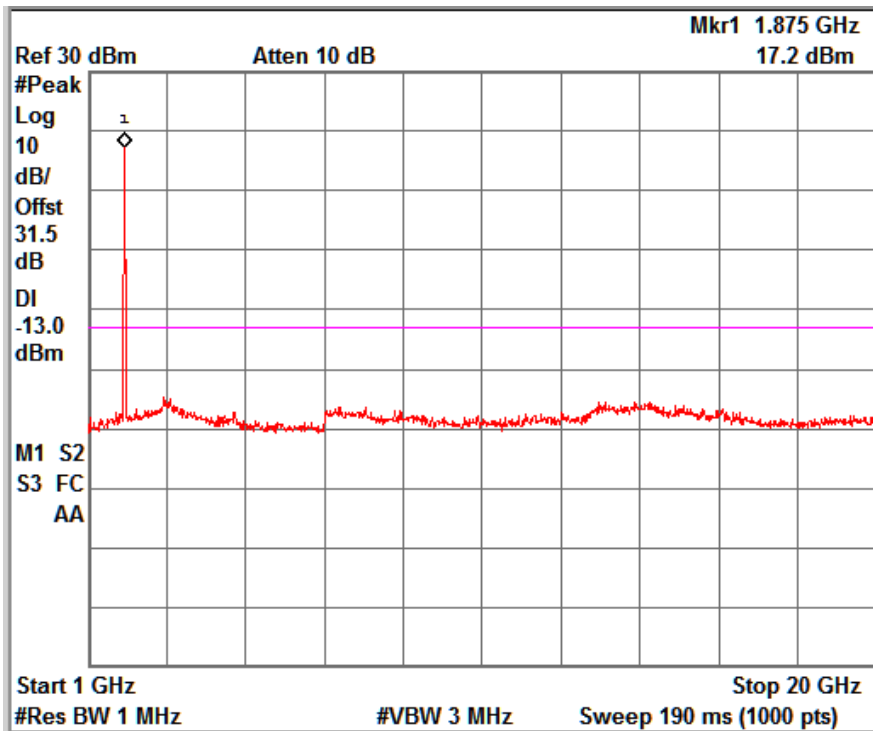
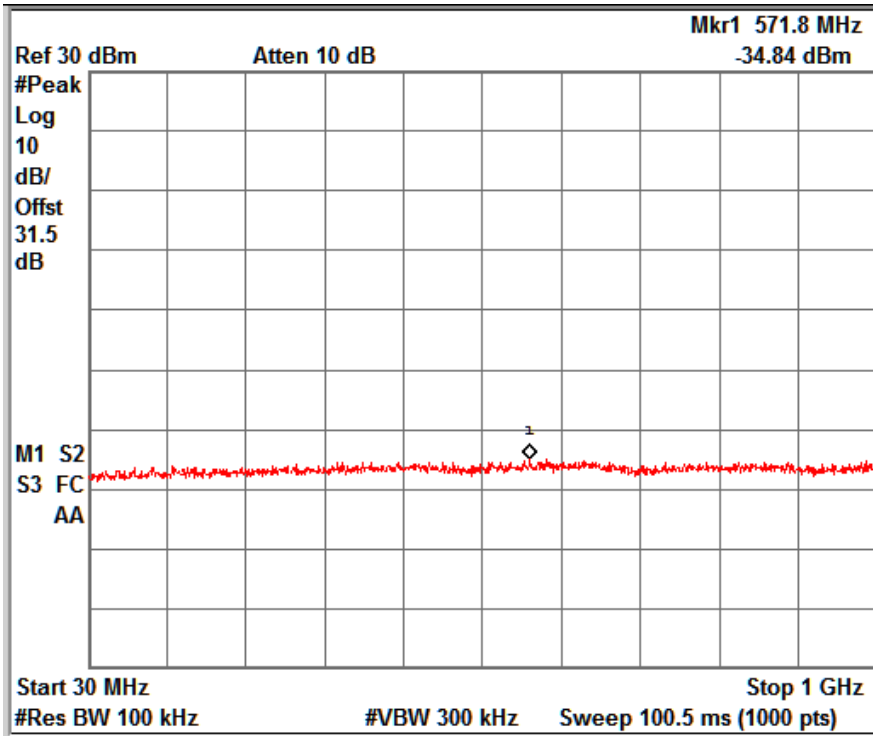
www.tuv.com

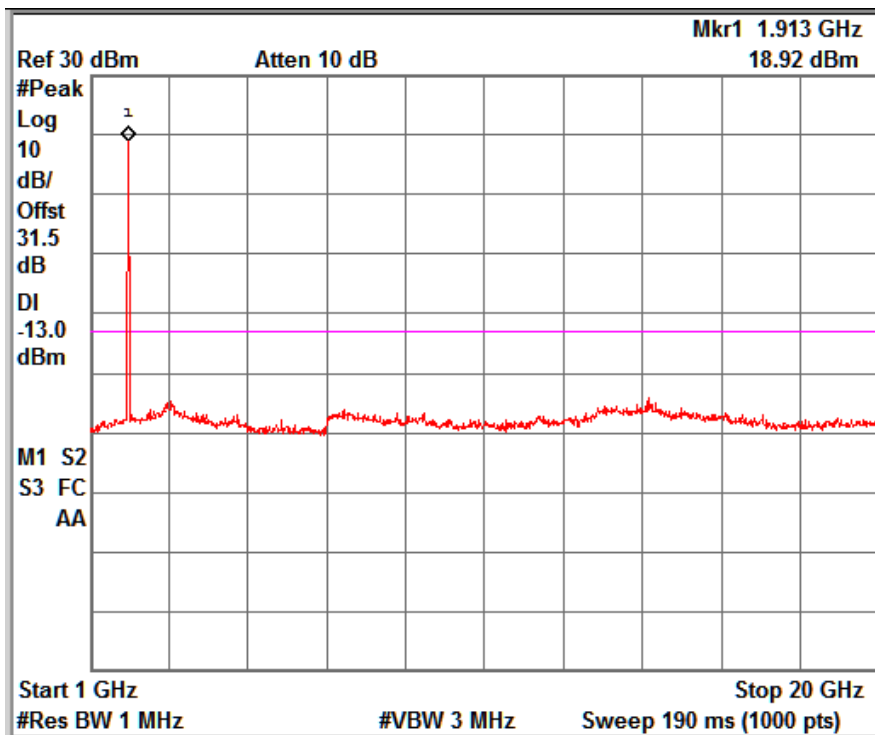
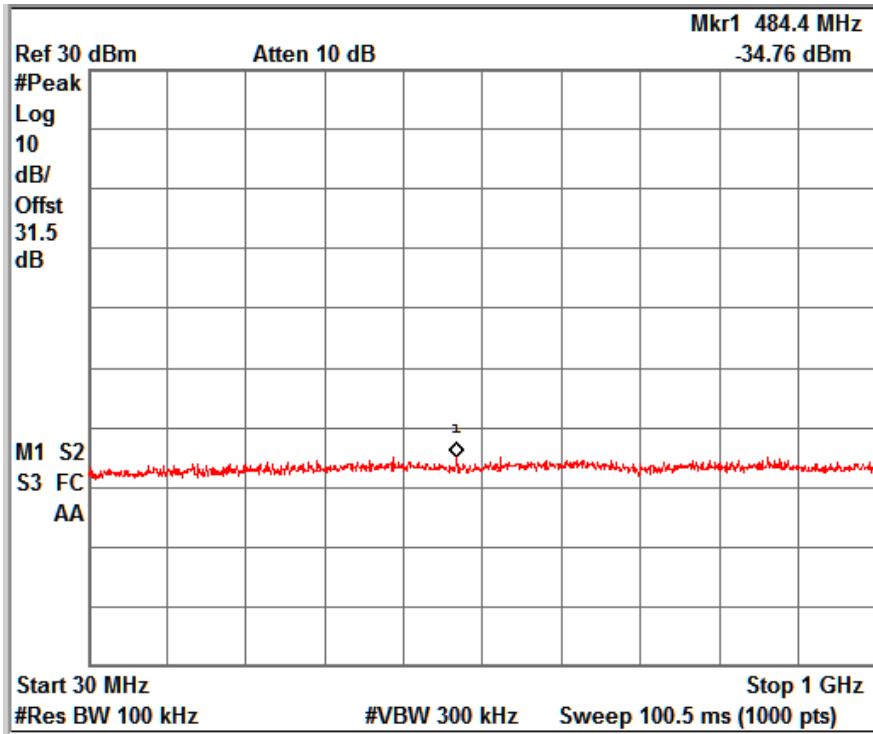

FDD Band 2_Channel Low_20MHz

www.tuv.com



FDD Band 2_Channel High_20MHz

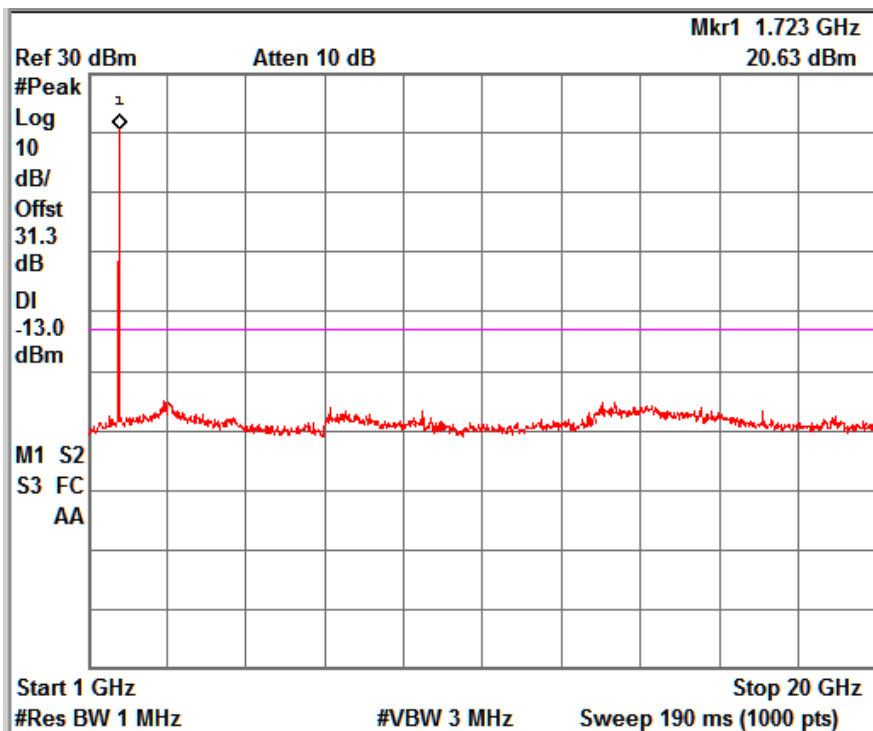
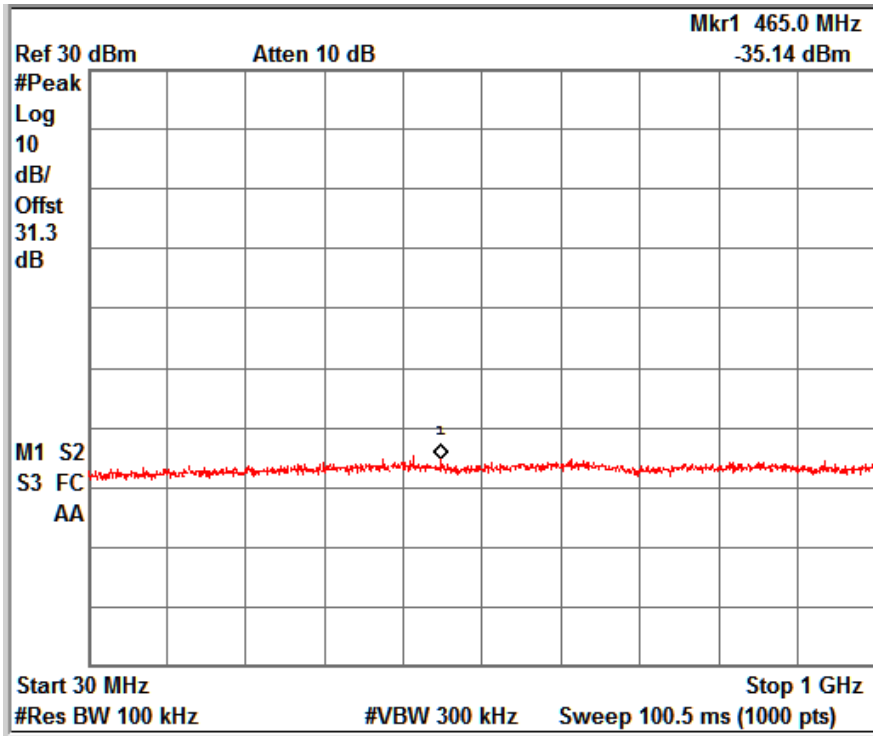

FDD Band 4_Channel Low_5MHz

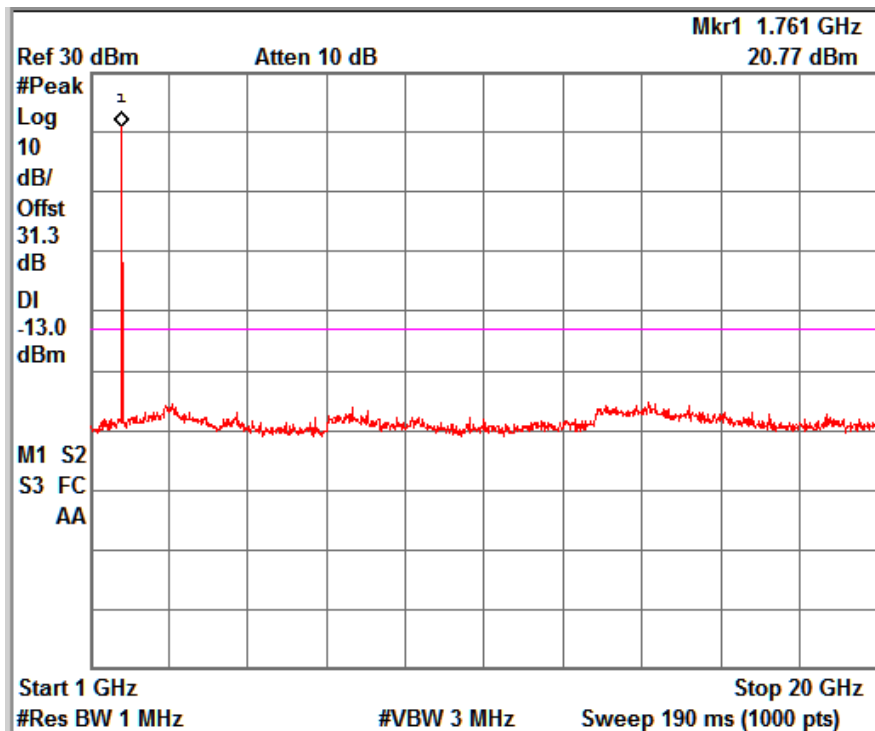
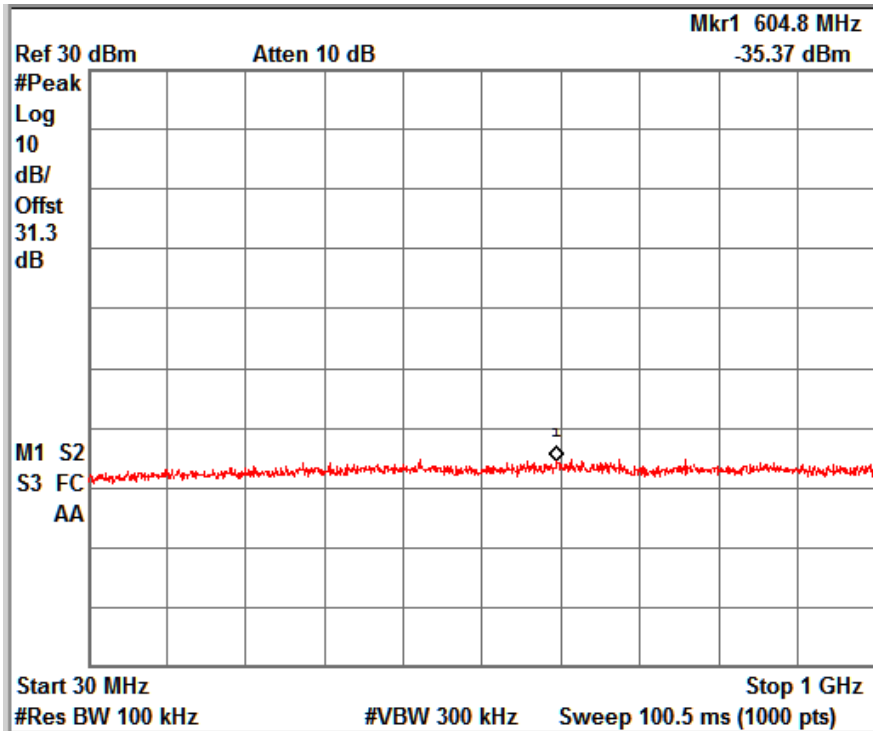

FDD Band 4_Channel High_5MHz

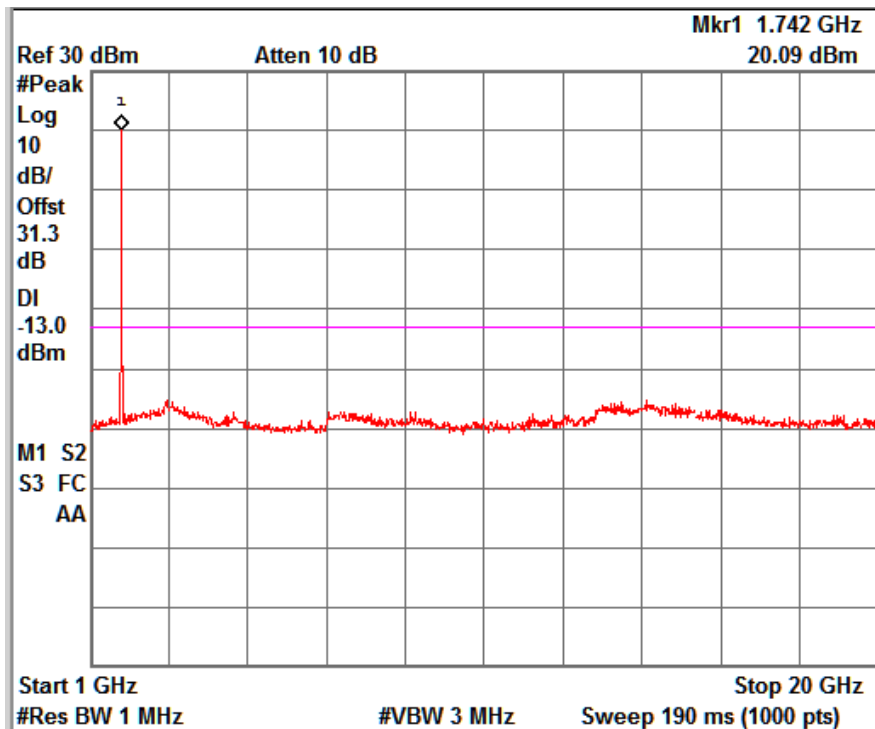
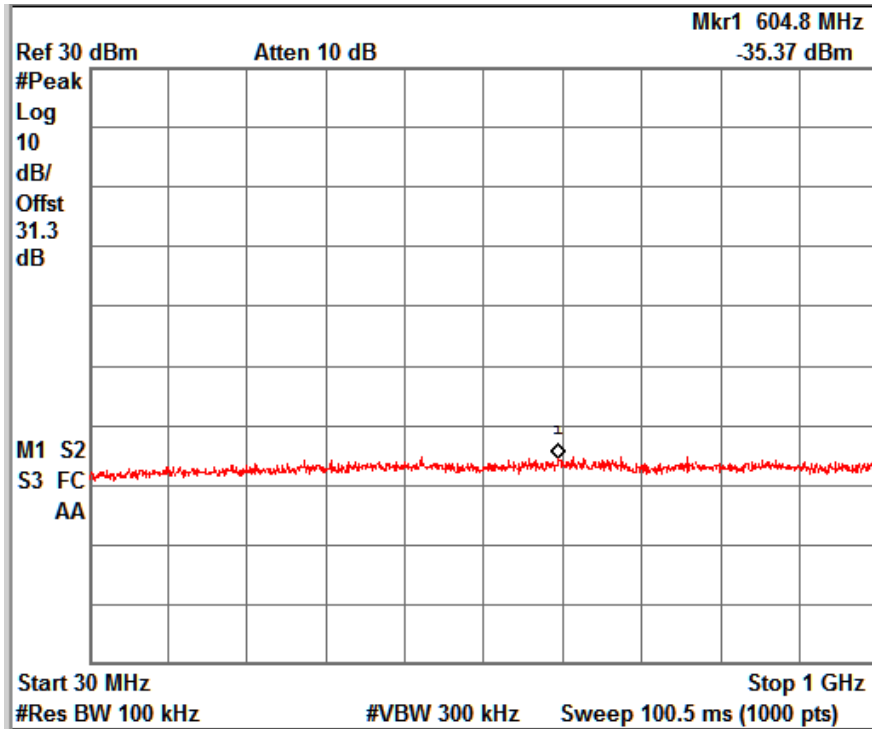

FDD Band 4_Channel Mid_10MHz

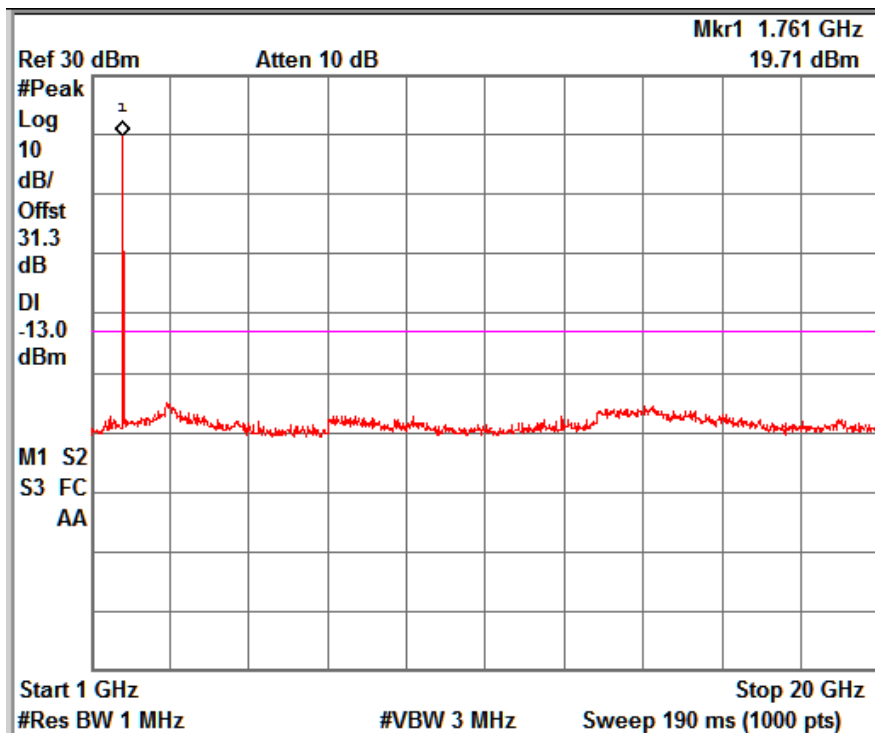
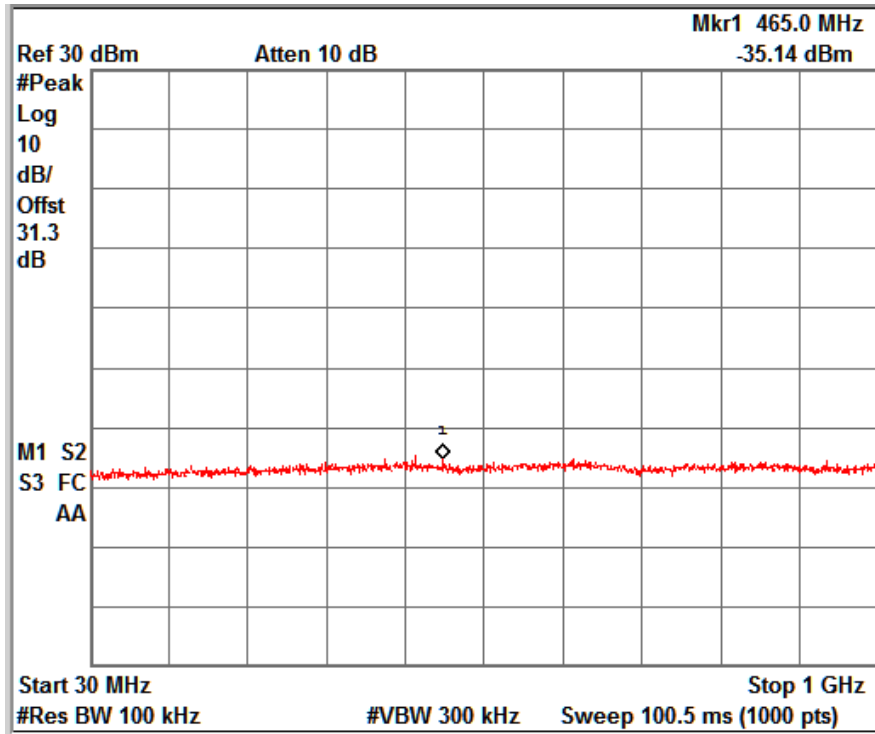

FDD Band4_Channel High_10MHz

www.tuv.com

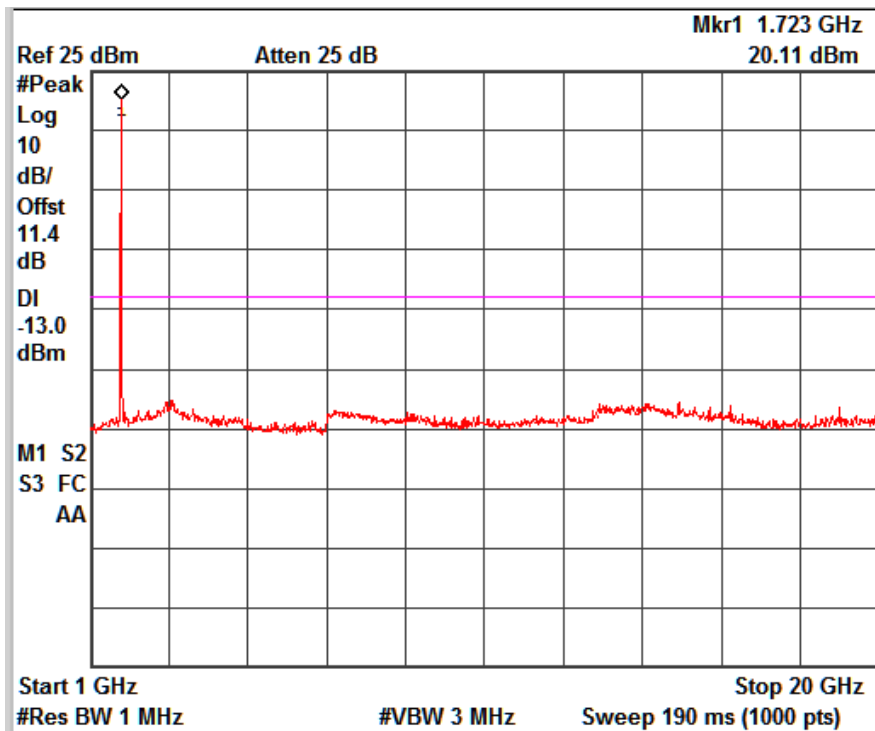
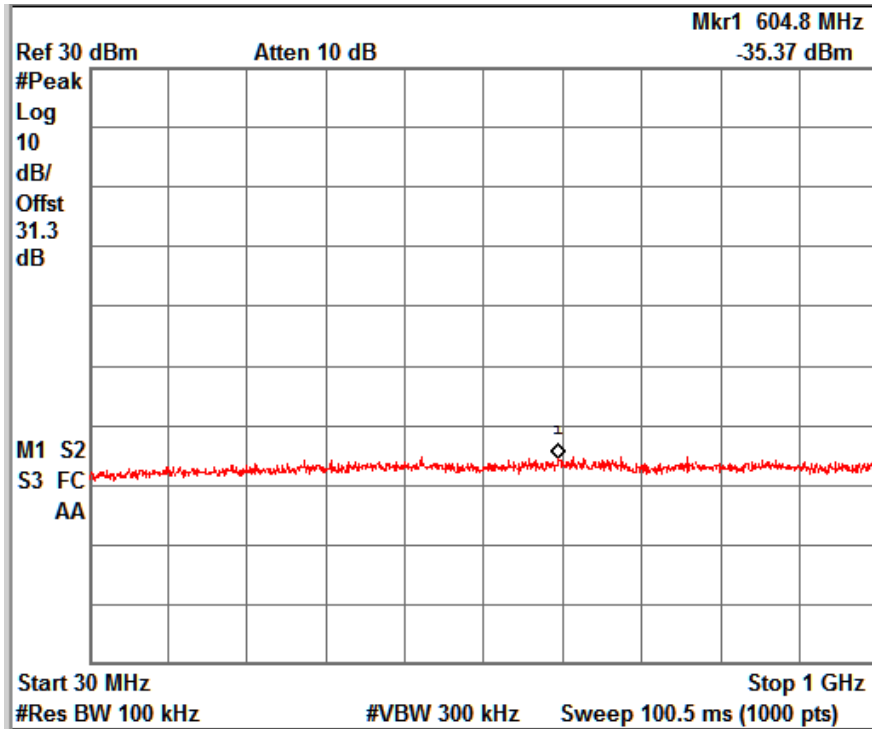

FDD Band4_Channel Low_15MHz

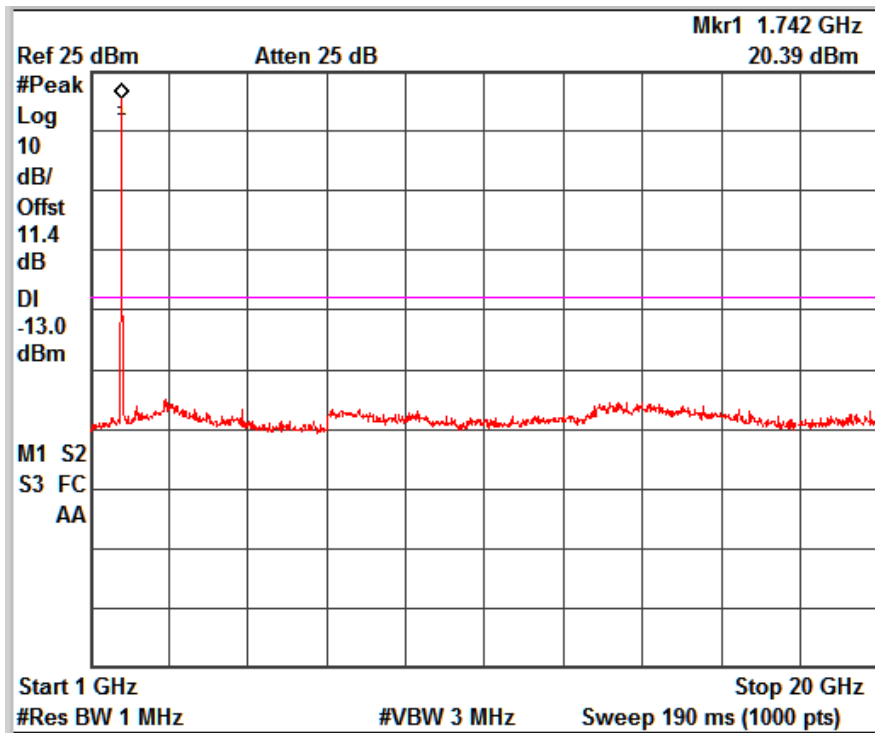
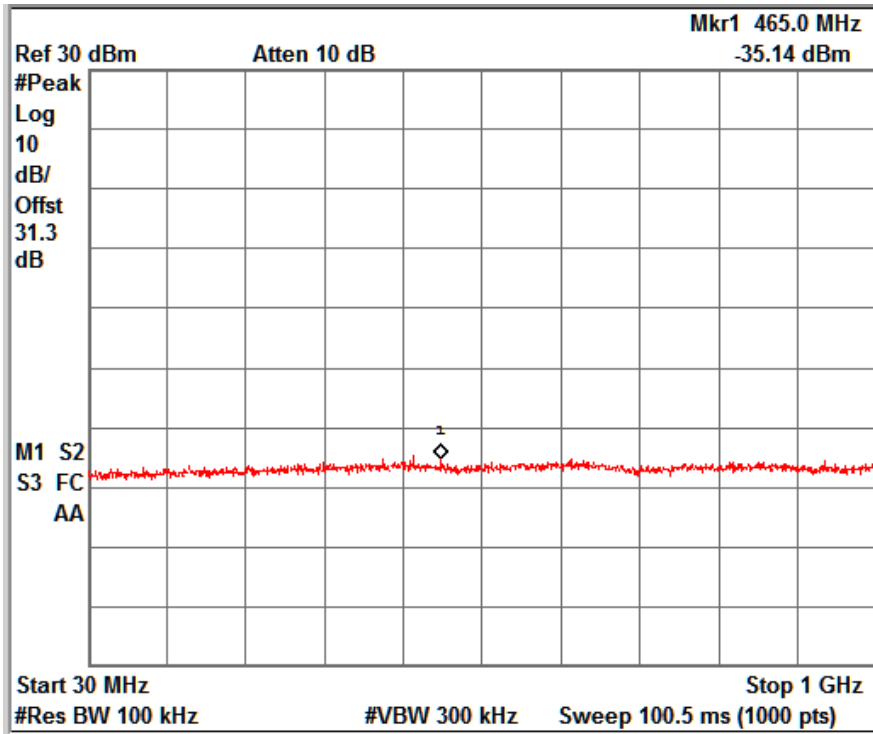

FDD Band4_Channel Mid_15MHz

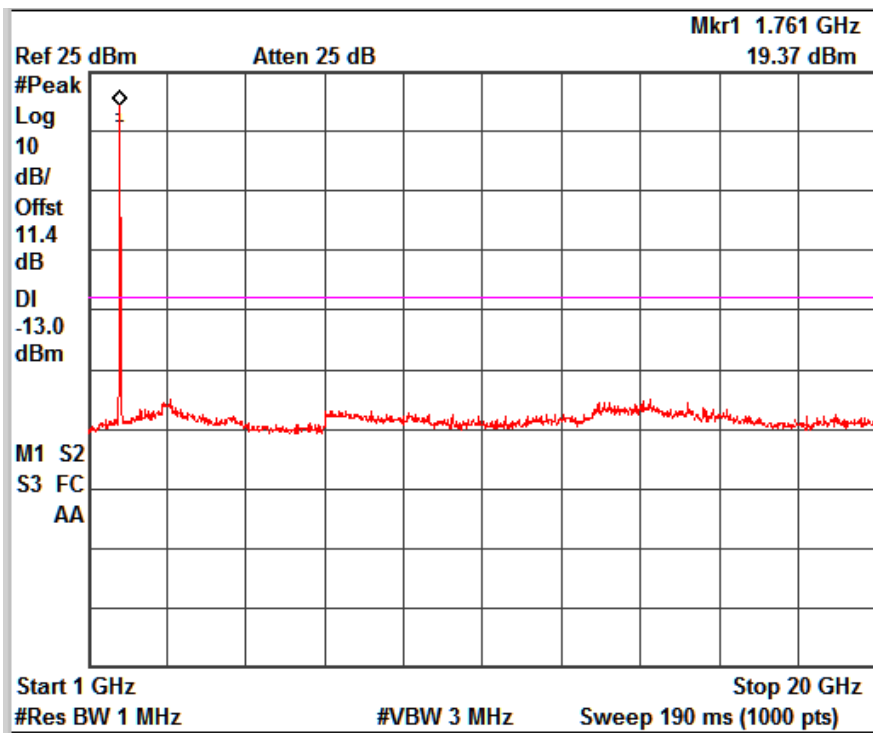
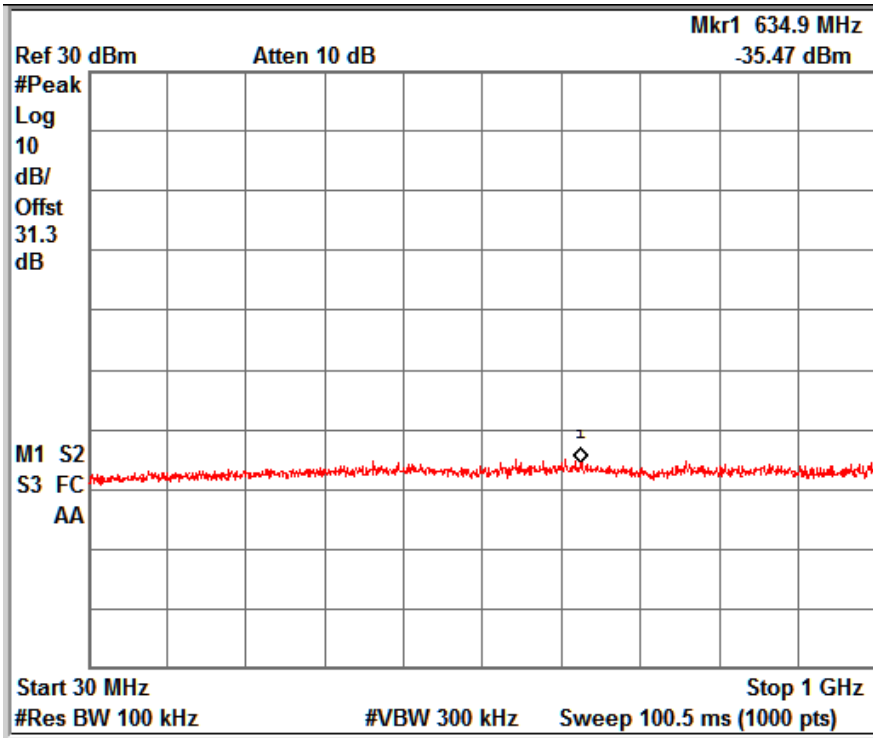
www.tuv.com

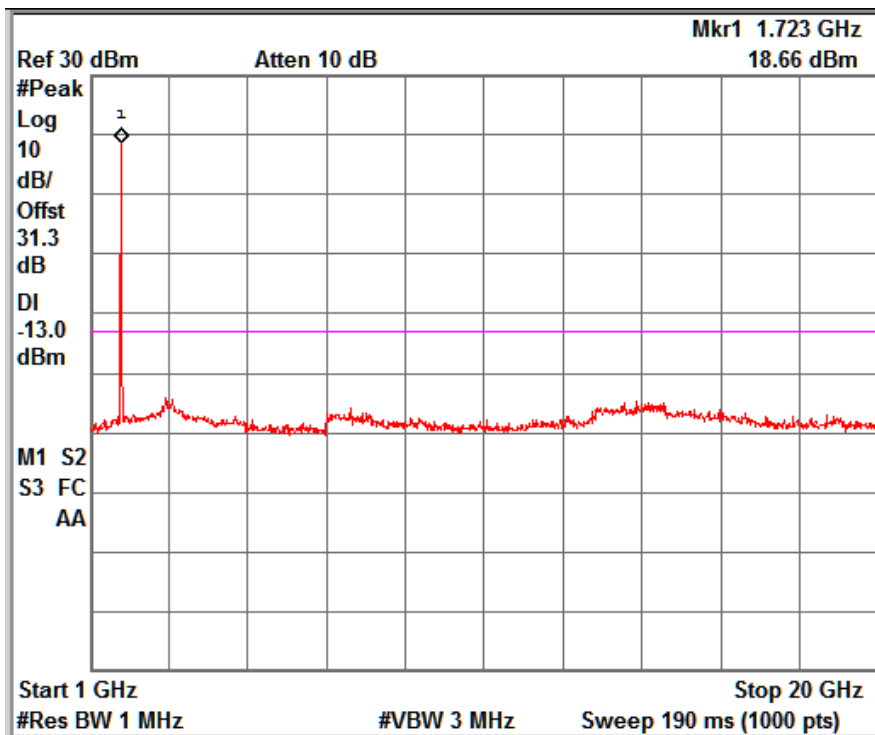
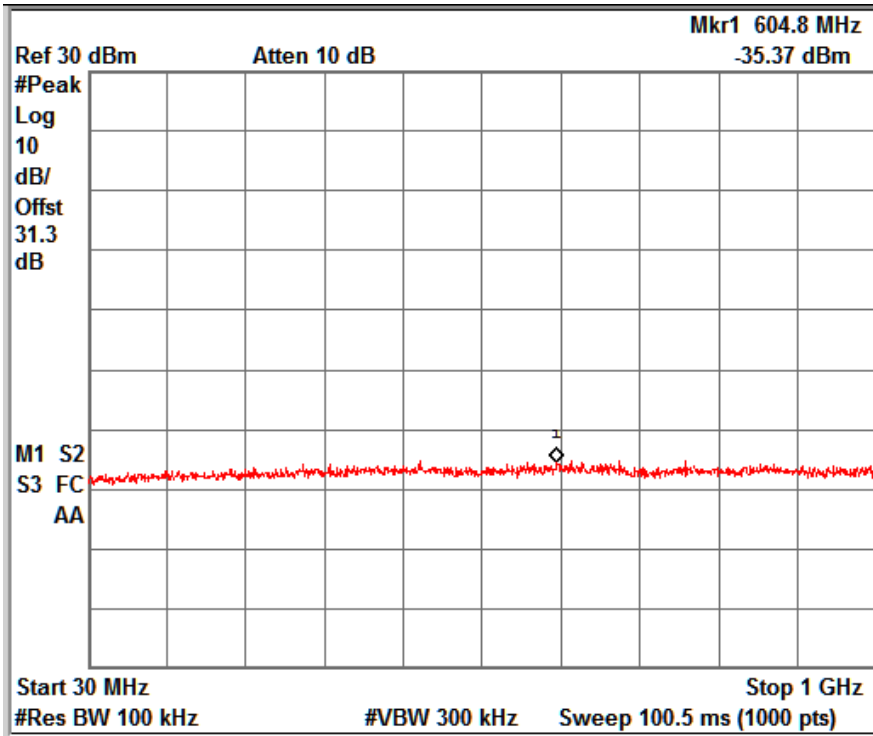

FDD Band4_Channel High_15MHz

www.tuv.com



FDD Band 4_Channel Low_20MHz

www.tuv.com

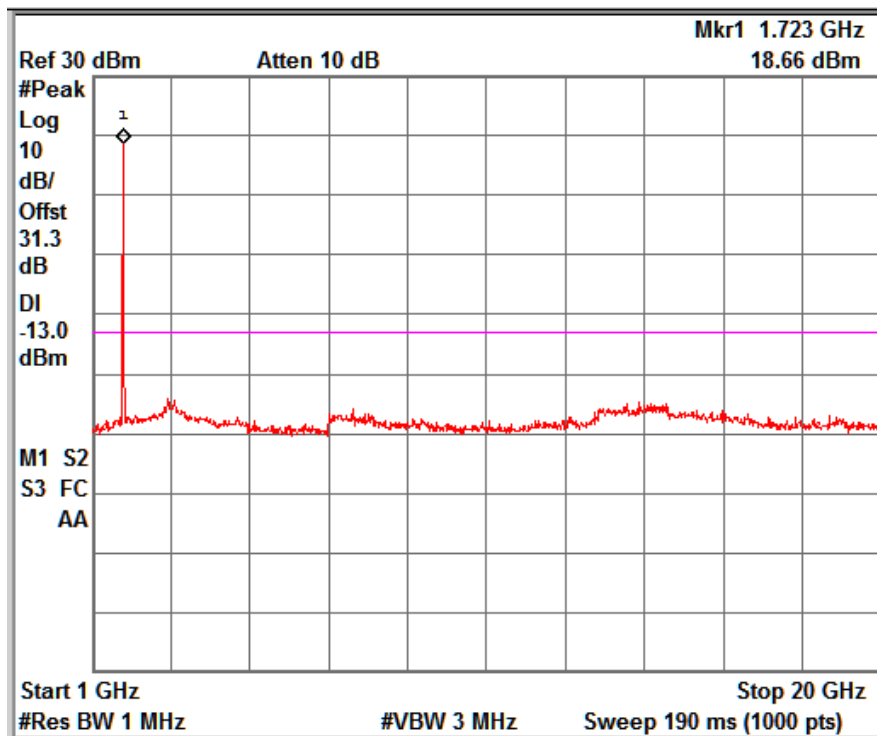
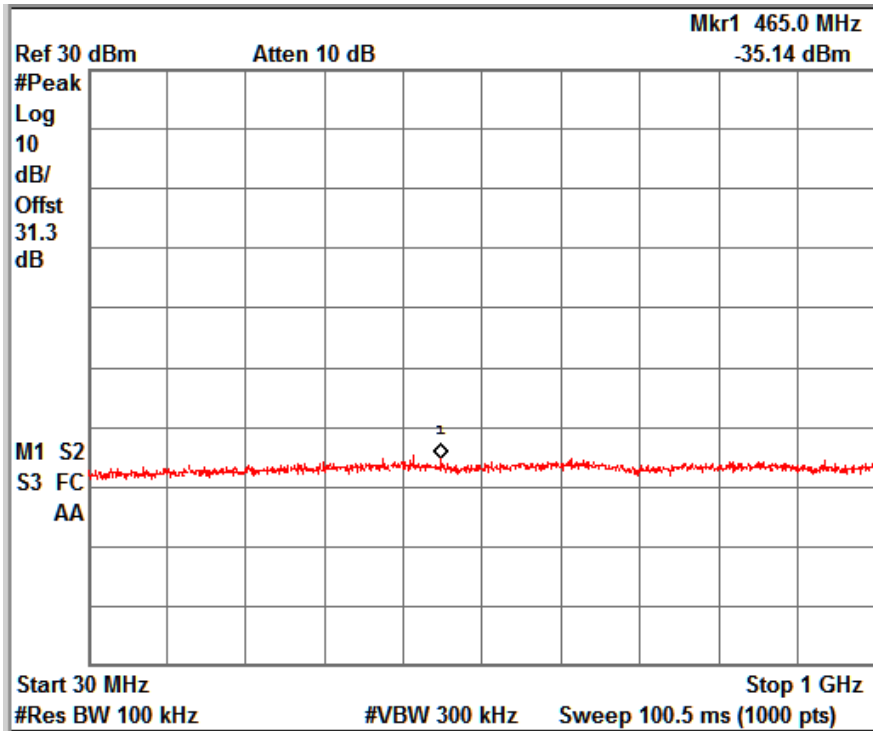

FDD Band 4_Channel Mid_20MHz

www.tuv.com

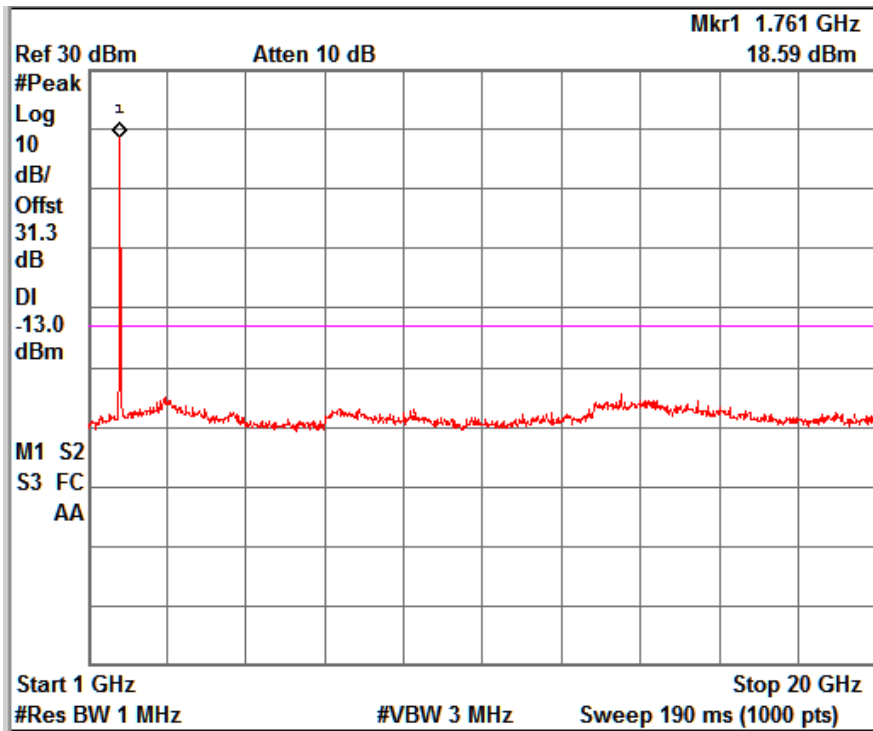
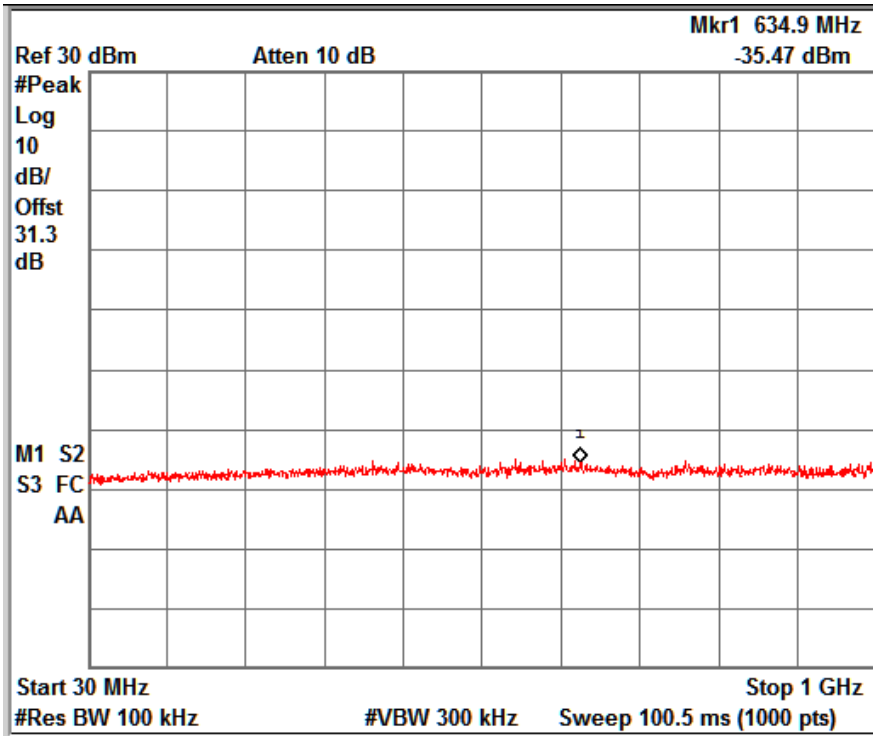

FDD Band 4_Channel High_20MHz

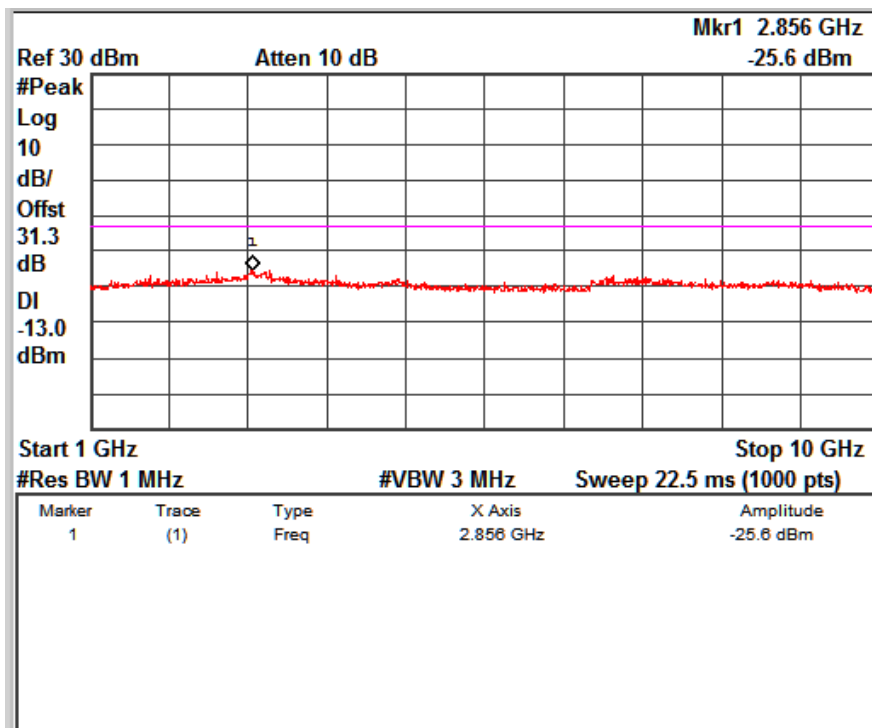
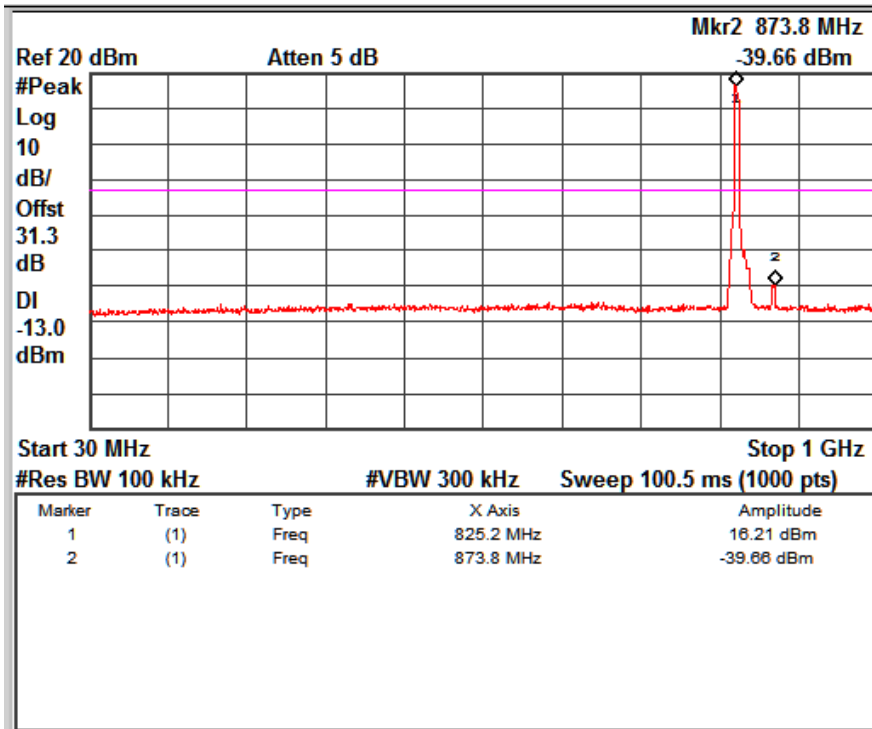

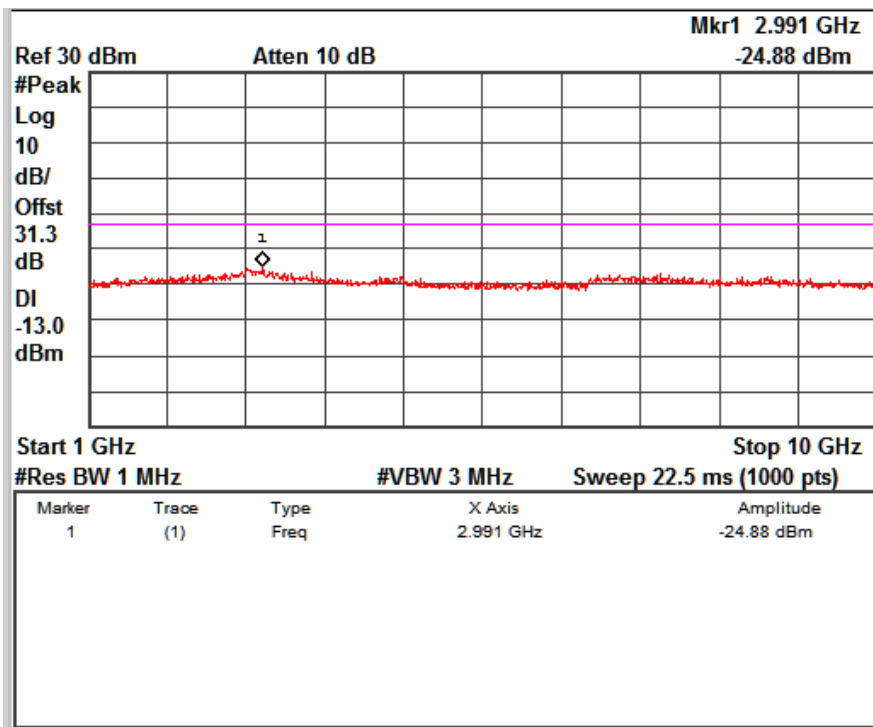
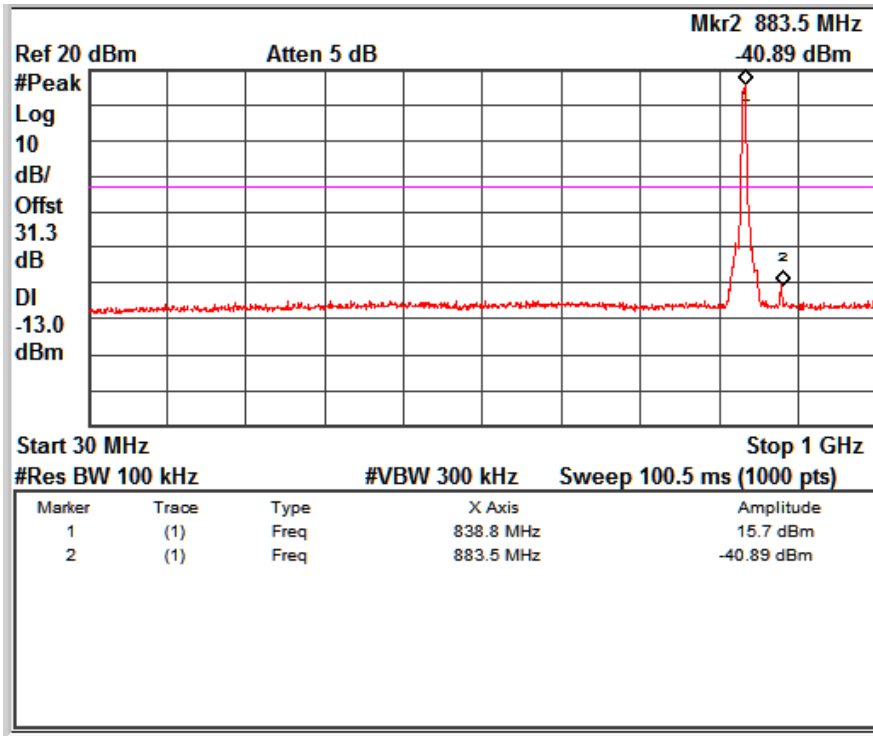
FDD Band 5_Channel Low_5MHz

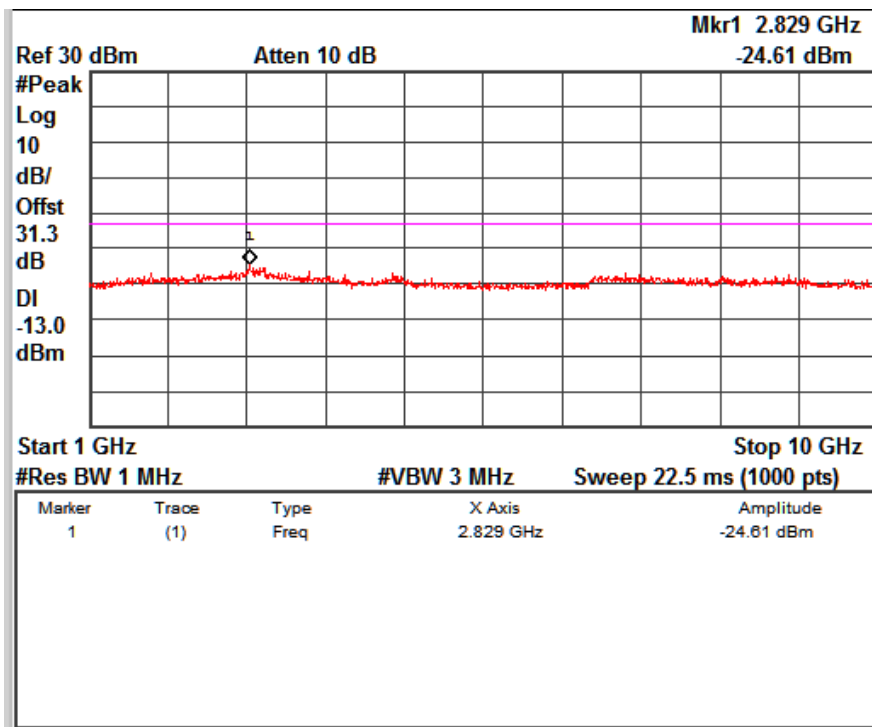
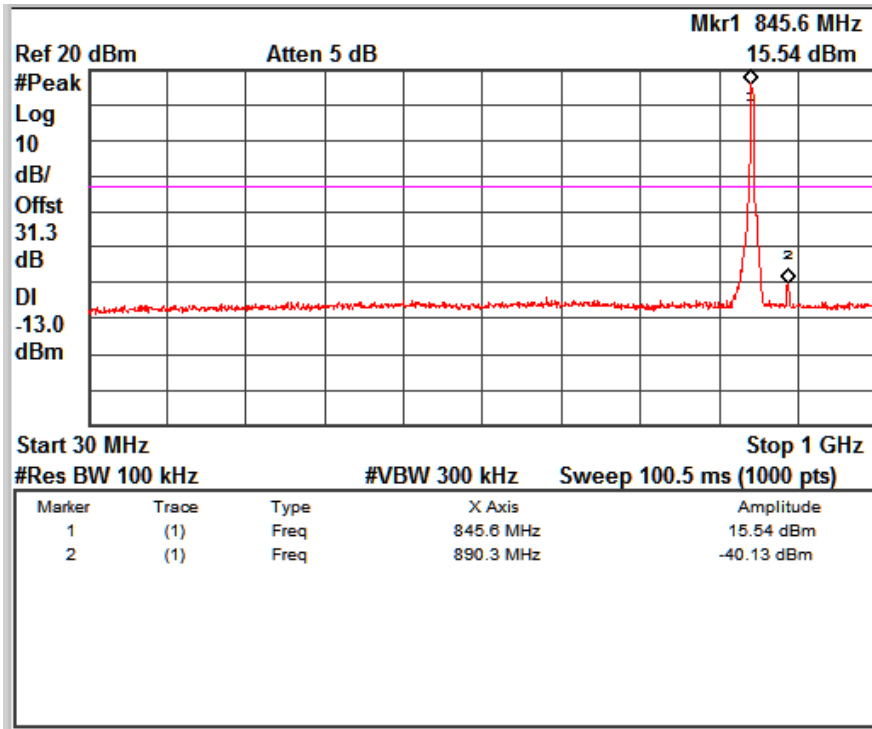

FDD Band 5_Channel Mid_5MHz

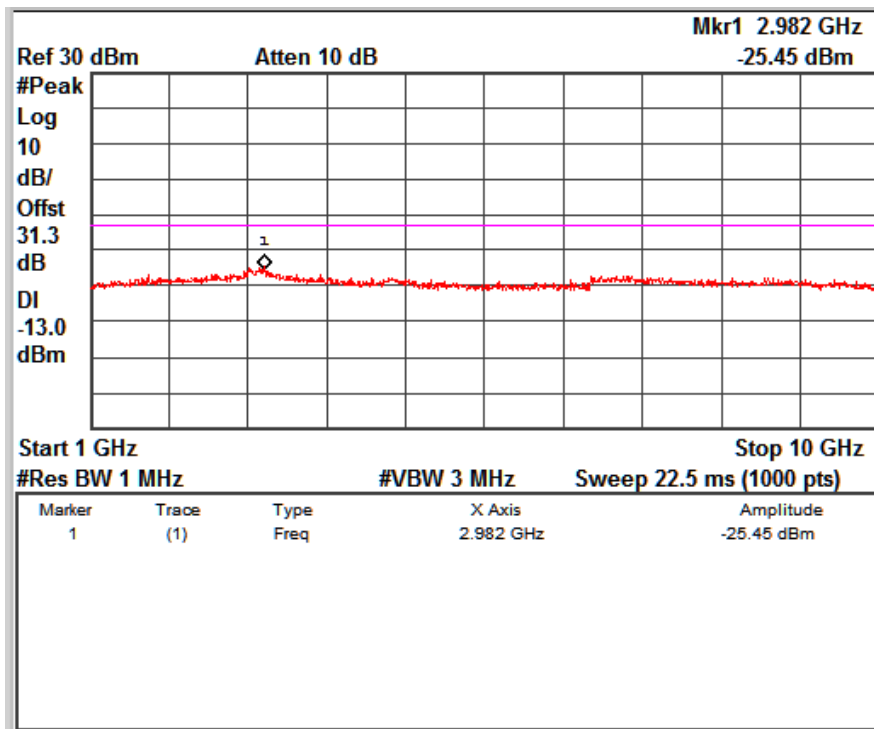
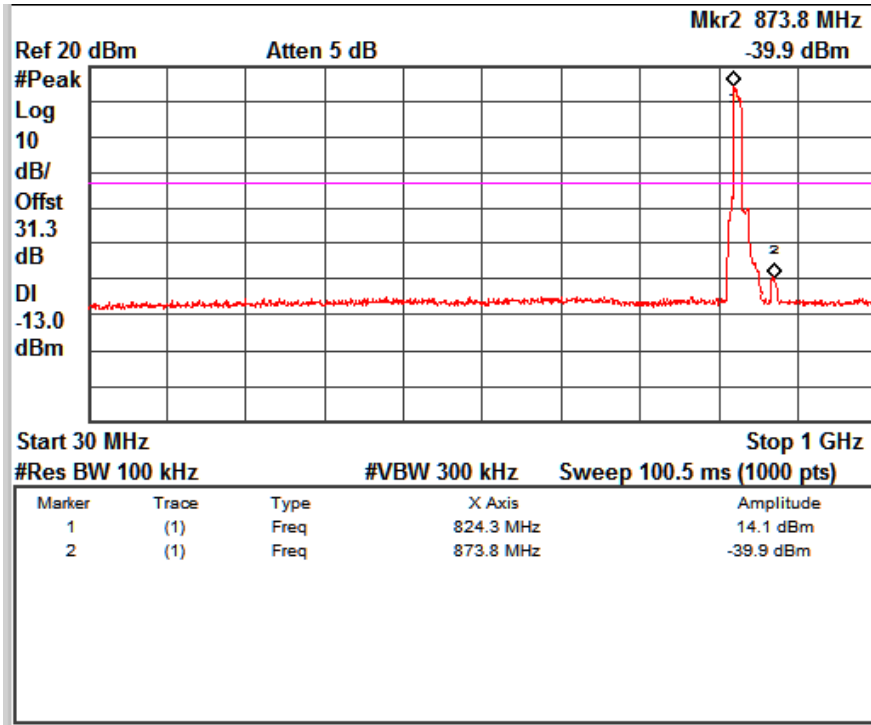

FDD Band 5_Channel High_5MHz



FDD Band 5_Channel Low_10MHz

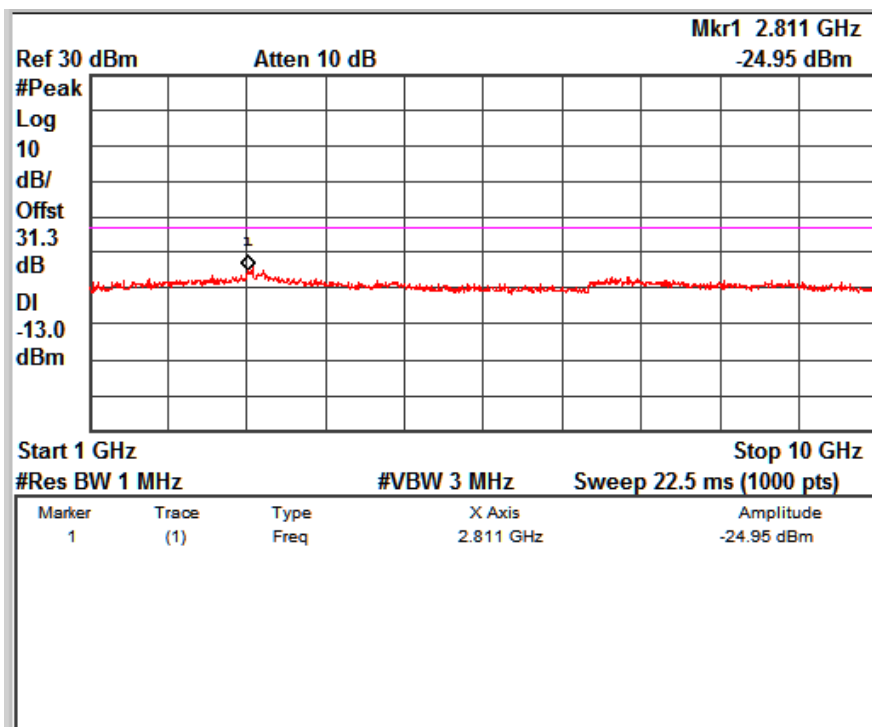
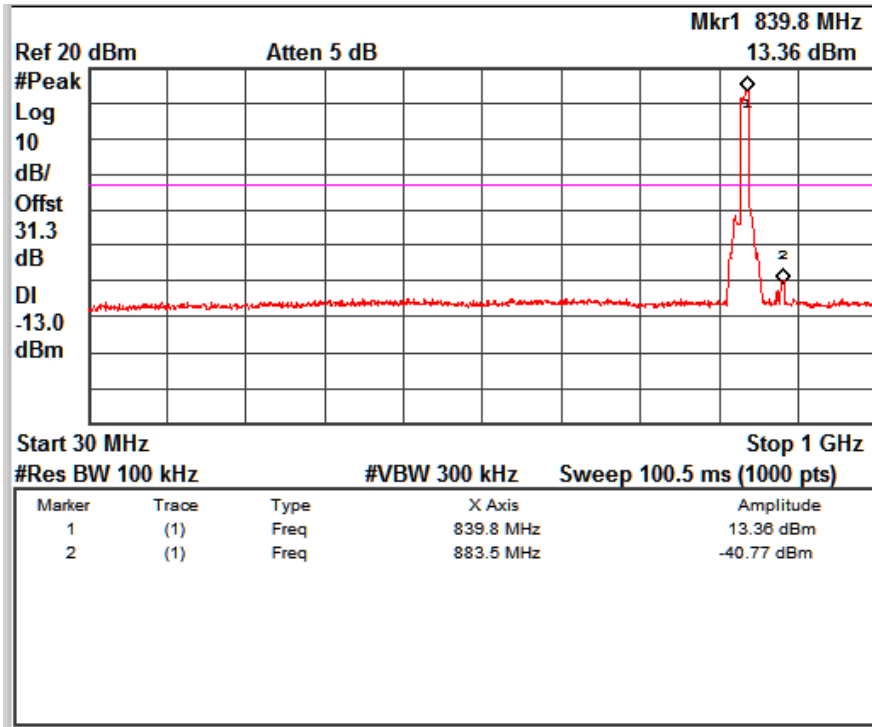

FDD Band 5_Channel Mid_10MHz

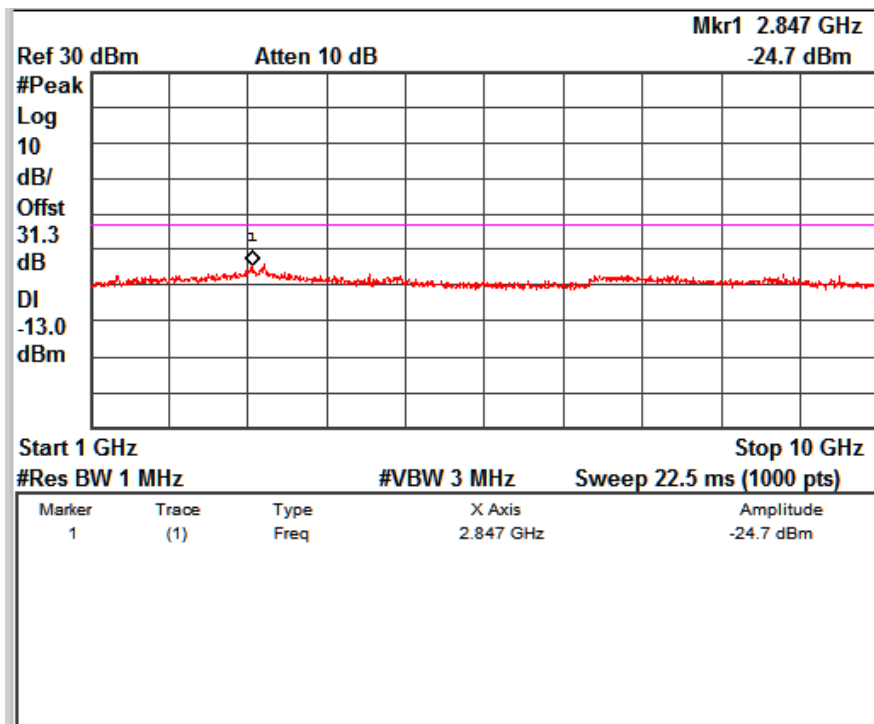
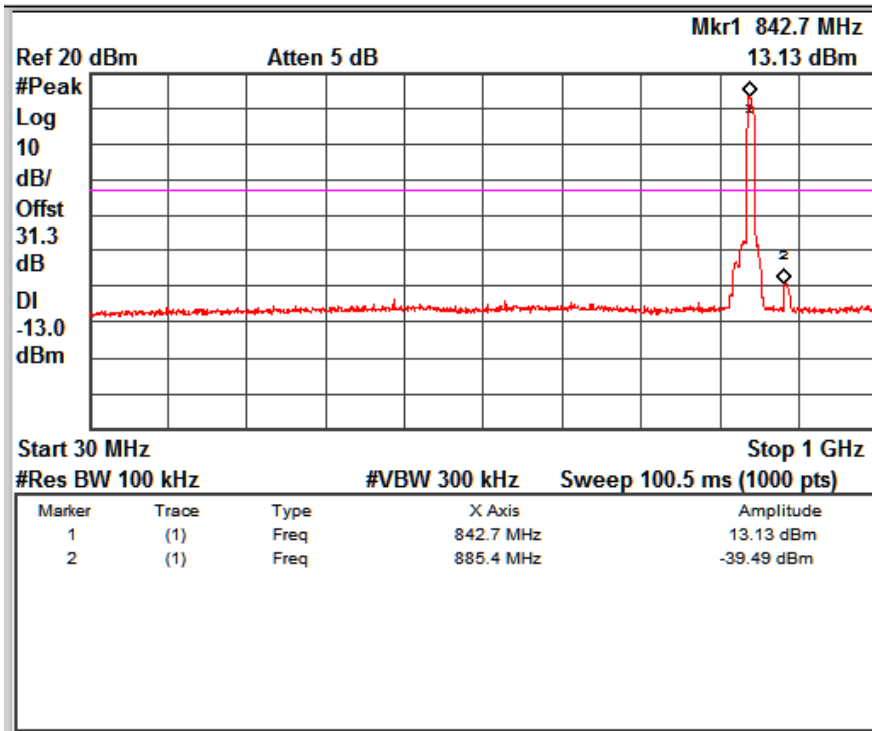

FDD Band 5_Channel High_10MHz

www.tuv.com

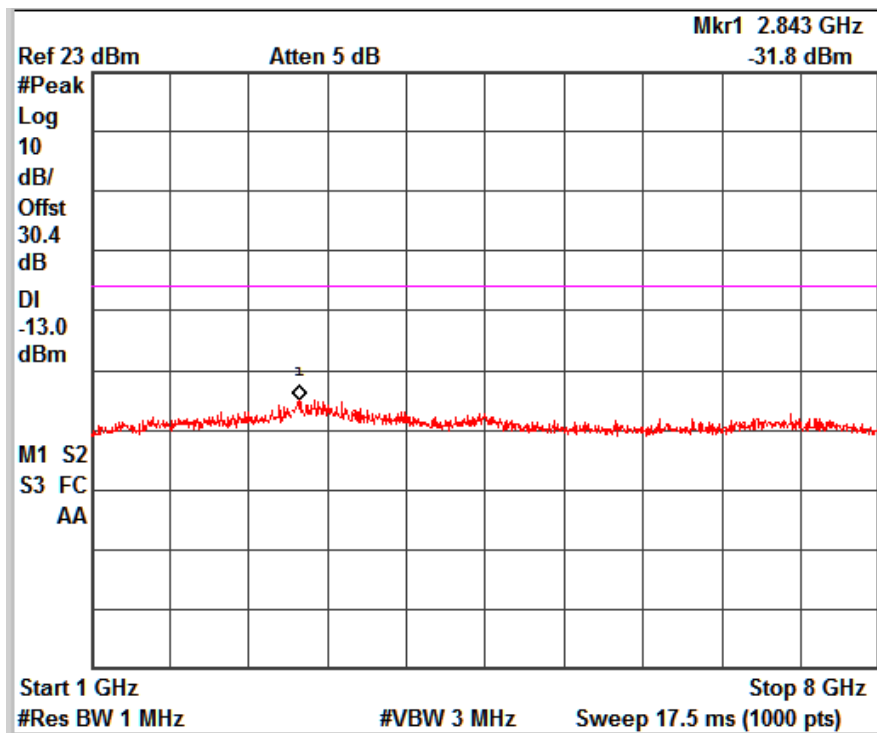
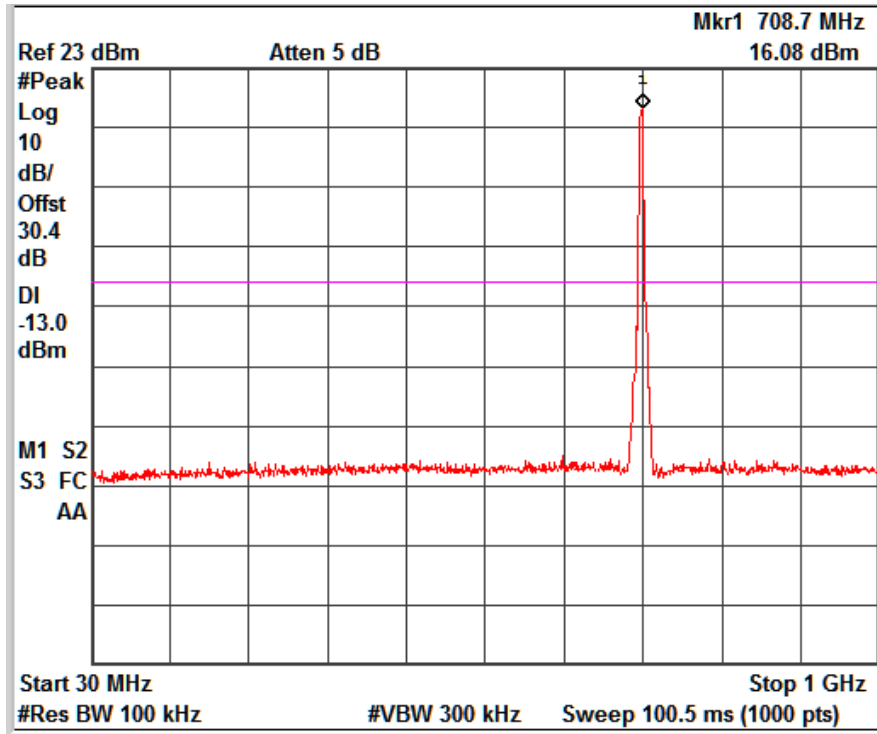

FDD Band 17_Channel Low_5MHz

www.tuv.com

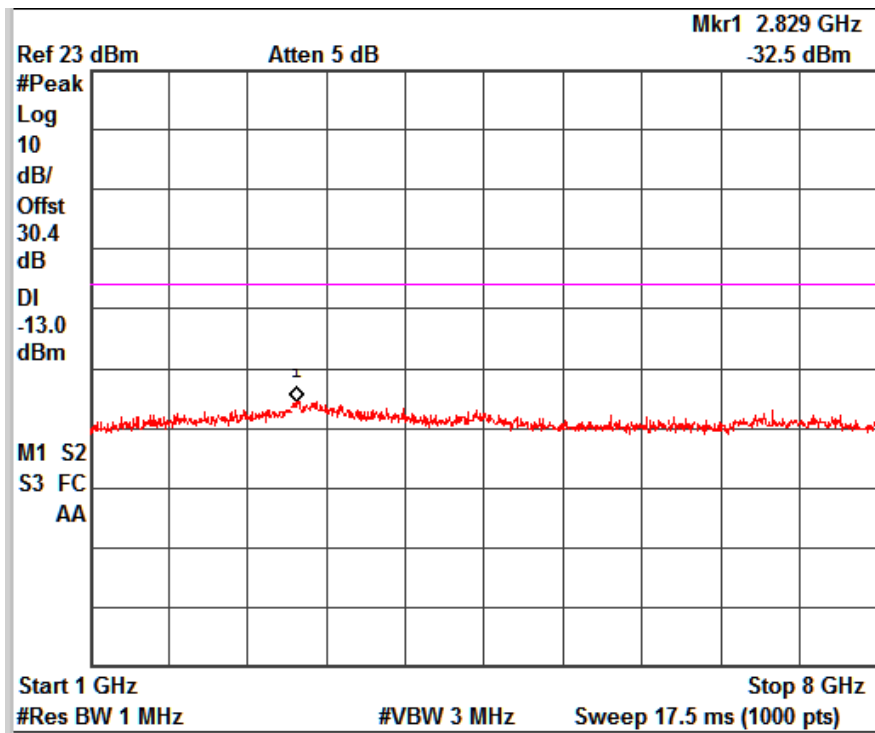
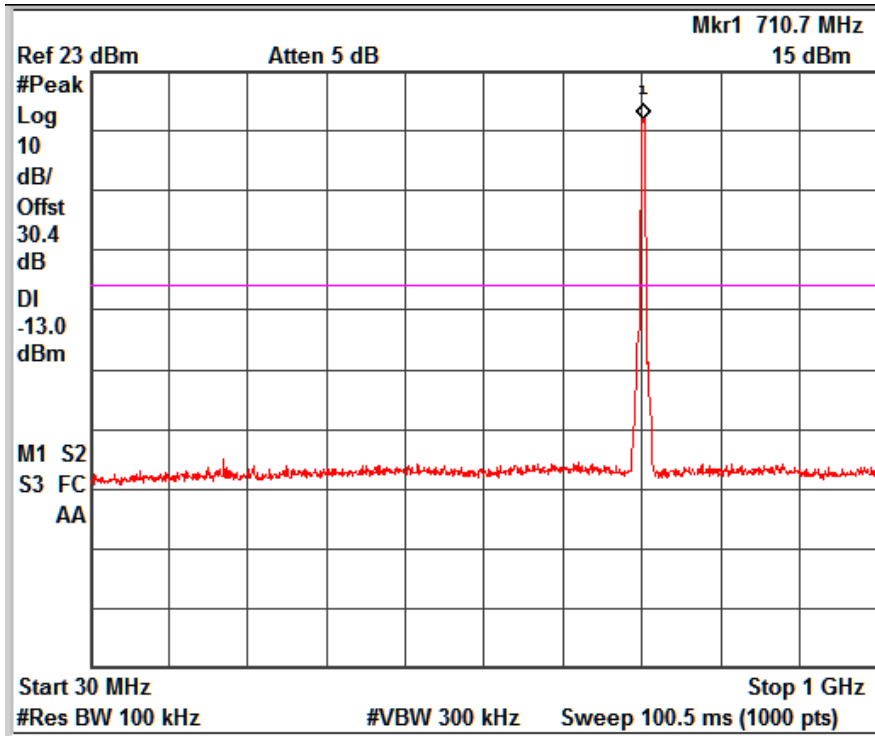

FDD Band 17_Channel Mid_5MHz

www.tuv.com

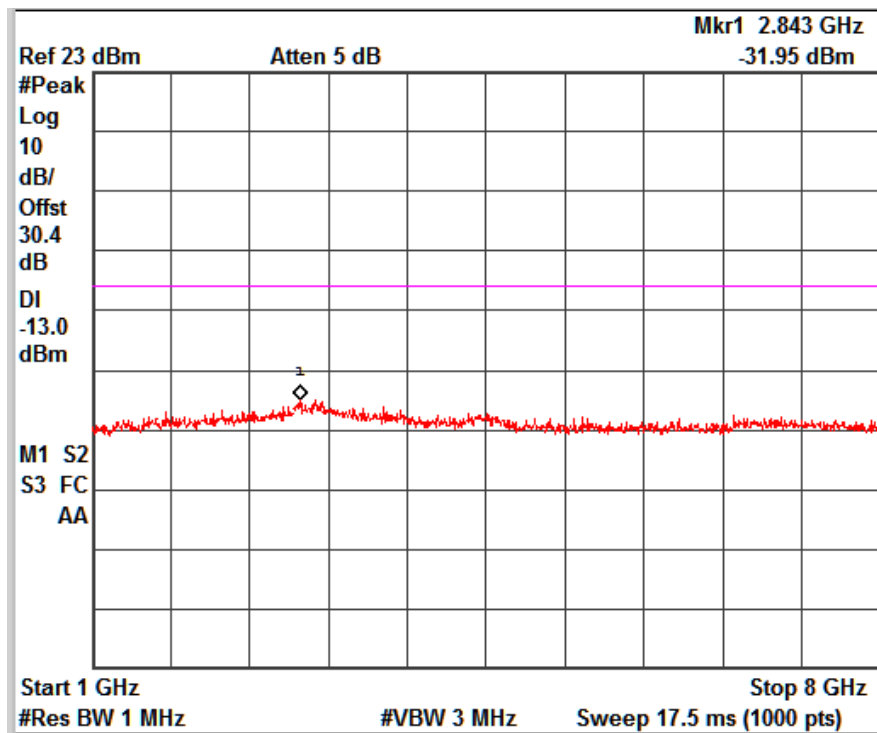
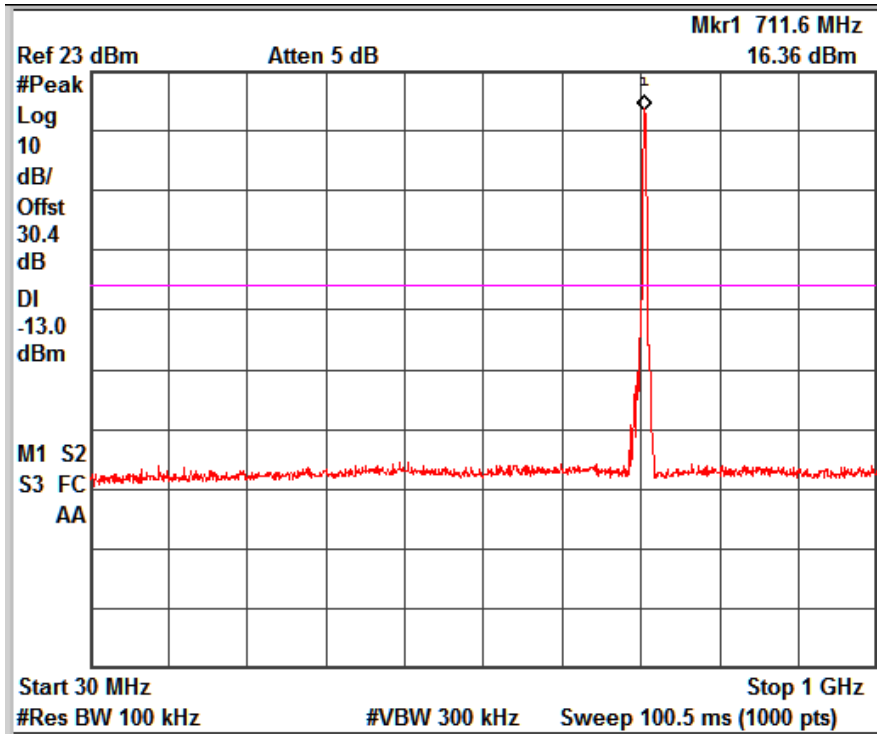

FDD Band 17_Channel Mid_5MHz

www.tuv.com

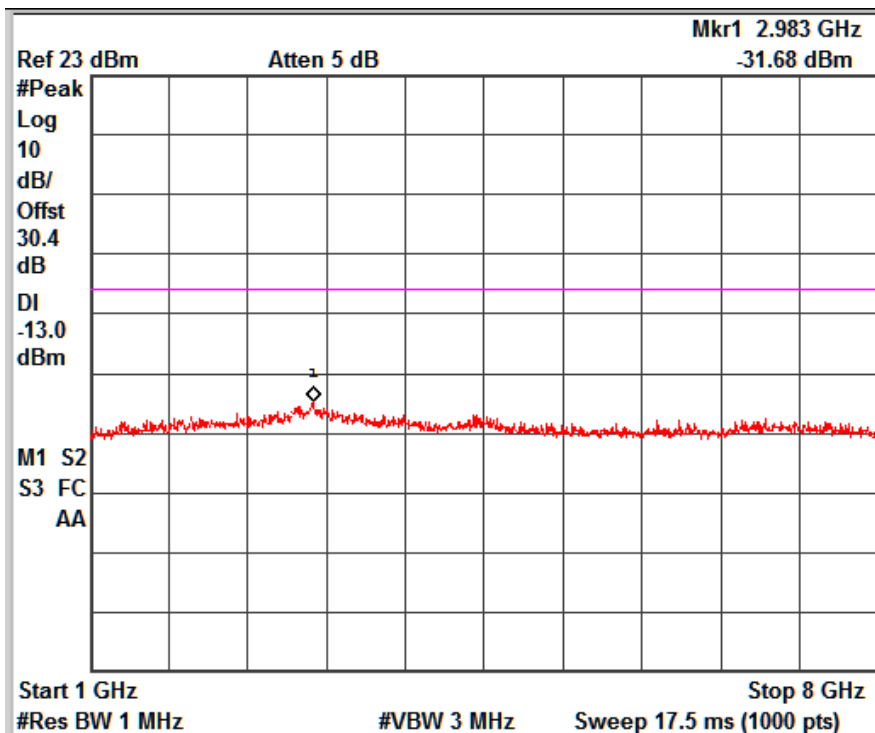
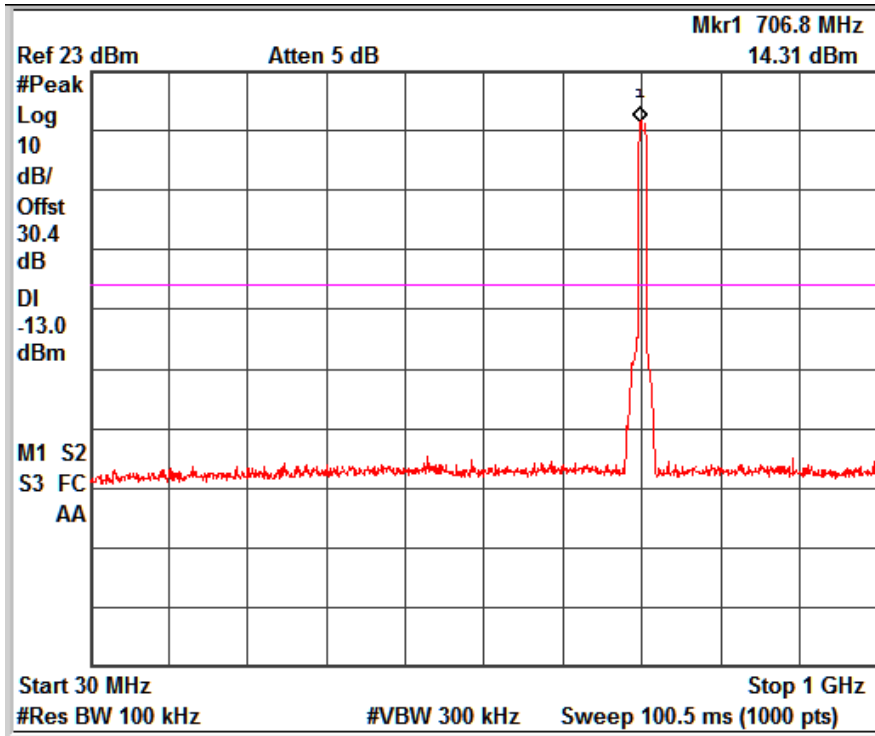

FDD Band 17_Channel Low_10MHz

www.tuv.com

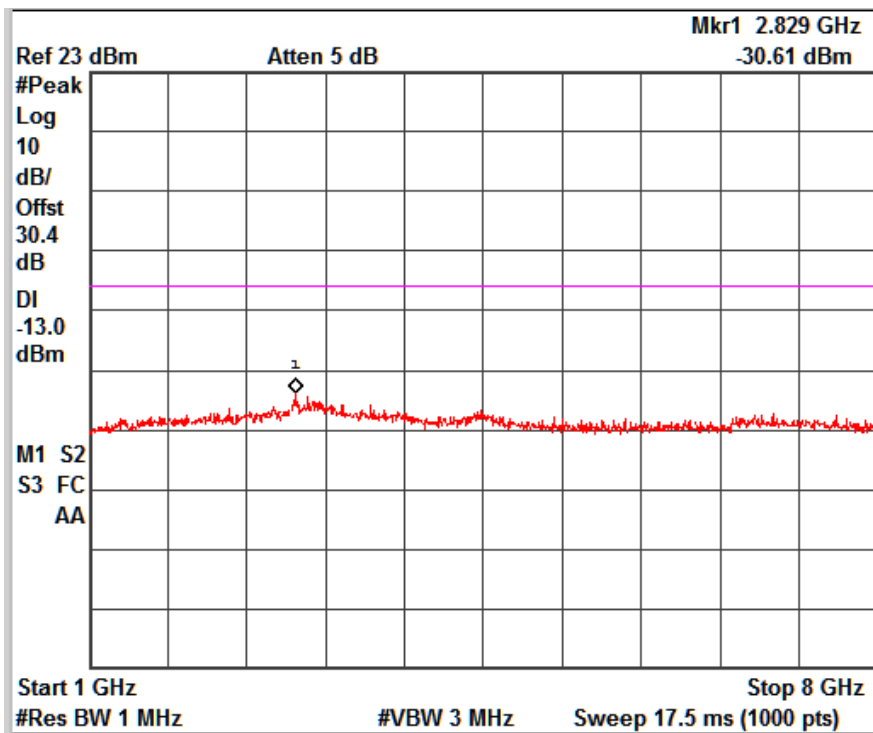
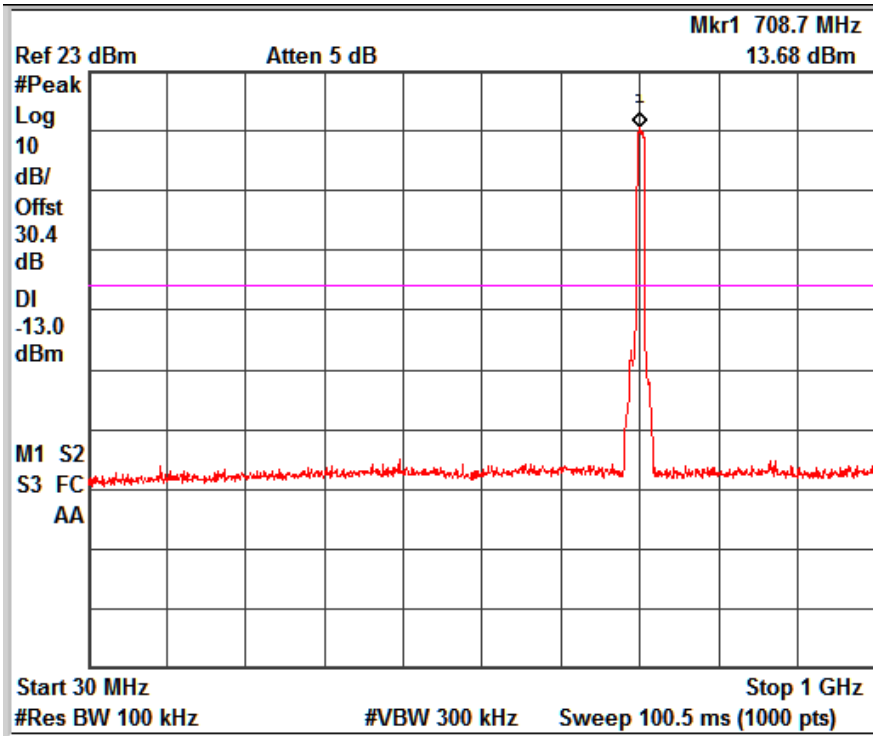

FDD Band 17_Channel Mid_10MHz

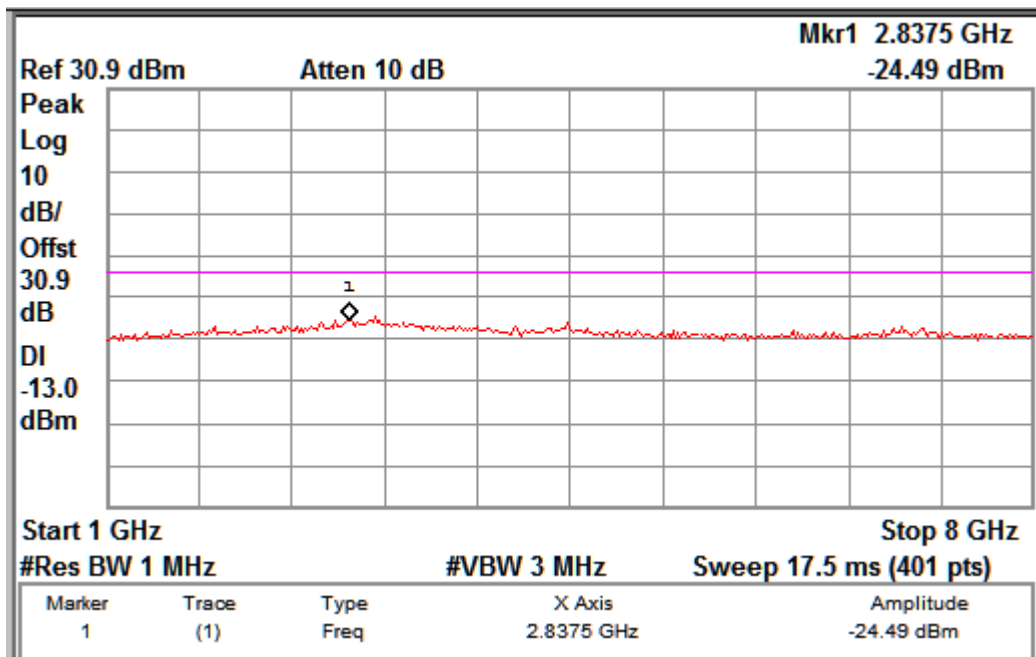
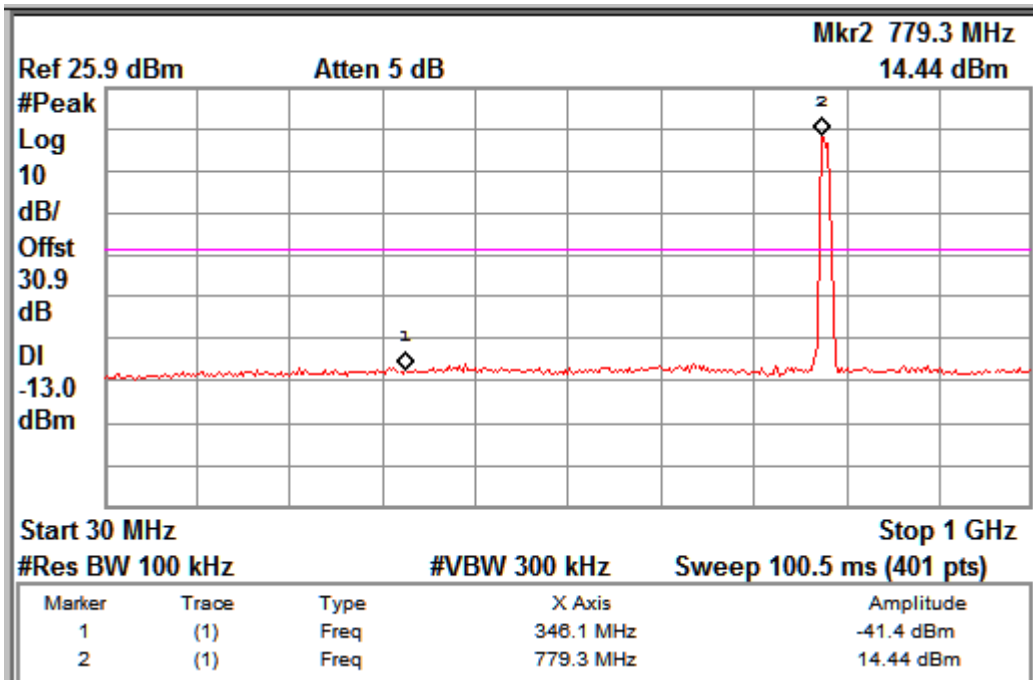

FDD Band 13_Channel Mid_10MHz

www.tuv.com

**Frequency Stability
Result**

Pass

Specification FCC Part 2.1055(a) (2), 22.355, , 24.235, 27.54 & RSS 132 Issue 3 section 5.3 ,
 Requirement RSS 133 Issue 6 section 6.3, RSS 139 Issue 3 section 6.4& RSS 130 Issue 1,section 4.3
 Frequency Stability shall be sufficient to ensure that the fundamental emission stay within the authorised frequency blok.

Test Setup:

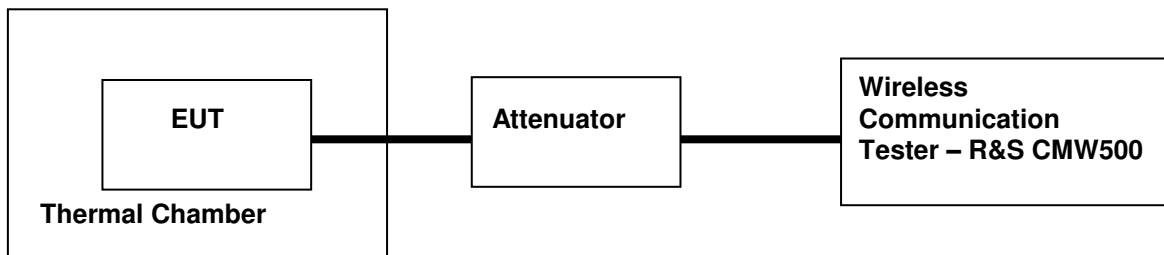

Note: For measurement of Frequency Stability test, method 9.0 in “971168 D01 Power Meas License Digital Systems v02r02” was used.

Frequency Stability on Voltage variation

Band	Bandwidth (MHz)	Voltage (Vdc)	Nominal Middle Frequency (MHz)	Maximum Frequency Error		Limit (ppm)
				(Hz)	(ppm)	
FDD 2	5	3.7	1880	-7.07	-0.0038	±2.5
		3.8	1880	-6.07	-0.0032	±2.5
		3.9	1880	-8.34	-0.0044	±2.5
		4.0	1880	-6.85	-0.0036	±2.5
		4.1	1880	-6.68	-0.0036	±2.5
		4.2	1880	-6.87	-0.0037	±2.5
	10	3.7	1880	-8.34	-0.0044	±2.5
		3.8	1880	-7.88	-0.0042	±2.5
		3.9	1880	-7.17	-0.0038	±2.5
		4.0	1880	-6.71	-0.0036	±2.5
		4.1	1880	-6.12	-0.0033	±2.5
		4.2	1880	-7.14	-0.0038	±2.5
	15	3.7	1880	-7.32	-0.0039	±2.5
		3.8	1880	-8.30	-0.0044	±2.5
		3.9	1880	-7.80	-0.0041	±2.5
		4.0	1880	-6.17	-0.0033	±2.5
		4.1	1880	-6.81	-0.0036	±2.5
		4.2	1880	-7.47	-0.0040	±2.5
	20	3.7	1880	-9.10	-0.0048	±2.5
		3.8	1880	-8.57	-0.0046	±2.5
3.9		1880	-6.51	-0.0035	±2.5	
4.0		1880	-6.37	-0.0034	±2.5	
4.1		1880	-5.91	-0.0031	±2.5	
4.2		1880	-8.23	-0.0044	±2.5	

www.tuv.com

FDD 4	5	3.7	1732.5	5.72	0.0033	±2.5
		3.8	1732.5	-5.59	-0.0032	±2.5
		3.9	1732.5	4.78	0.0028	±2.5
		4.0	1732.5	-5.99	-0.0035	±2.5
		4.1	1732.5	6.87	0.0040	±2.5
		4.2	1732.5	5.48	0.0032	±2.5
	10	3.7	1732.5	7.02	0.0041	±2.5
		3.8	1732.5	2.98	0.0017	±2.5
		3.9	1732.5	-5.39	-0.0031	±2.5
		4.0	1732.5	-3.38	-0.0020	±2.5
		4.1	1732.5	-2.6	-0.0015	±2.5
		4.2	1732.5	5.34	0.0031	±2.5
	15	3.7	1732.5	-5.13	-0.0027	±2.5
		3.8	1732.5	-6.81	-0.0036	±2.5
		3.9	1732.5	-7.62	-0.0041	±2.5
		4.0	1732.5	-4.48	-0.0024	±2.5
		4.1	1732.5	-4.94	-0.0026	±2.5
		4.2	1732.5	-7.58	-0.0040	±2.5
	20	3.7	1732.5	-4.03	-0.0023	±2.5
		3.8	1732.5	-6.51	-0.0038	±2.5
3.9		1732.5	-8.60	-0.0050	±2.5	
4.0		1732.5	-4.28	-0.0025	±2.5	
4.1		1732.5	4.85	0.0028	±2.5	
4.2		1732.5	-8.58	-0.0050	±2.5	
FDD 5	5	3.7	836.5	-2.92	-0.0035	±2.5
		3.8	836.5	-3.35	-0.0040	±2.5
		3.9	836.5	-2.09	-0.0025	±2.5
		4.0	836.5	-6.46	-0.0077	±2.5
		4.1	836.5	-3.81	-0.0046	±2.5
		4.2	836.5	-3.19	-0.0038	±2.5
	10	3.7	836.5	-2.86	-0.0034	±2.5
		3.8	836.5	-2.12	-0.0025	±2.5
		3.9	836.5	-2.35	-0.0028	±2.5
		4.0	836.5	-6.18	-0.0074	±2.5
		4.1	836.5	-2.17	-0.0026	±2.5
		4.2	836.5	-3.22	-0.0038	±2.5
FDD 17	5	3.7	710.0	-3.41	-0.0048	±2.5
		3.8	710.0	-4.12	-0.0058	±2.5
		3.9	710.0	-2.67	-0.0038	±2.5
		4.0	710.0	-7.46	-0.0035	±2.5
		4.1	710.0	-4.58	-0.0065	±2.5
		4.2	710.0	-3.21	-0.0045	±2.5
	10	3.7	710.0	-4.86	-0.0068	±2.5
		3.8	710.0	-3.12	-0.0044	±2.5
		3.9	710.0	-3.35	-0.0047	±2.5
		4.0	710.0	-5.18	-0.0073	±2.5
		4.1	710.0	-2.56	-0.0036	±2.5
		4.2	710.0	-4.67	-0.0066	±2.5
FDD 13	10	3.7	782	-7.8	-0.00997	±2.5
		3.8	782	-7.77	-0.00994	±2.5
		3.9	782	-8.08	-0.01033	±2.5
		4.0	782	-7.40	-0.00946	±2.5
		4.1	782	-6.59	-0.00843	±2.5
		4.2	782	-6.58	-0.00841	±2.5

Frequency Stability on Temperature variation

Band	Bandwidth (MHz)	Channel Frequency (MHz)	Temperature (°C)	Maximum Frequency Error		Limit (ppm)
				(Hz)	(ppm)	
FDD 2	5	1880	-30	-7.08	-0.0038	±2.5
		1880	-20	-7.16	-0.0038	±2.5
		1880	-10	-7.41	-0.0039	±2.5
		1880	0	-8.12	-0.0043	±2.5
		1880	10	-6.17	-0.0033	±2.5
		1880	20	-4.99	-0.0027	±2.5
		1880	30	-7.12	-0.0038	±2.5
		1880	40	-8.73	-0.0046	±2.5
		1880	50	-5.02	-0.0027	±2.5
	10	1880	-30	-5.72	-0.0030	±2.5
		1880	-20	-6.12	-0.0033	±2.5
		1880	-10	-6.34	-0.0034	±2.5
		1880	0	-7.45	-0.0040	±2.5
		1880	10	-7.15	-0.0038	±2.5
		1880	20	-6.17	-0.0033	±2.5
		1880	30	-8.64	-0.0046	±2.5
		1880	40	-7.10	-0.0038	±2.5
		1880	50	-10.50	-0.0056	±2.5
	15	1880	-30	-6.85	-0.0036	±2.5
		1880	-20	-7.07	-0.0038	±2.5
		1880	-10	-6.55	-0.0035	±2.5
		1880	0	-8.33	-0.0044	±2.5
		1880	10	-6.25	-0.0033	±2.5
		1880	20	-10.59	-0.0056	±2.5
		1880	30	-7.27	-0.0039	±2.5
		1880	40	-7.54	-0.0040	±2.5
		1880	50	-6.59	-0.0035	±2.5
	20	1880	-30	-5.31	-0.0028	±2.5
		1880	-20	-6.12	-0.0033	±2.5
		1880	-10	-7.72	-0.0041	±2.5
		1880	0	-7.14	-0.0038	±2.5
		1880	10	-8.04	-0.0043	±2.5
		1880	20	-6.44	-0.0034	±2.5
		1880	30	-8.94	-0.0048	±2.5
		1880	40	-9.00	-0.0048	±2.5
		1880	50	-8.70	-0.0046	±2.5
FDD 4	5	1732.5	-30	6.65	0.0038	±2.5
		1732.5	-20	5.76	0.0033	±2.5
		1732.5	-10	4.72	0.0027	±2.5
		1732.5	0	5.16	0.0030	±2.5

		1732.5	10	6.07	0.0035	±2.5			
		1732.5	20	5.79	0.0033	±2.5			
		1732.5	30	4.15	0.0024	±2.5			
		1732.5	40	-3.73	-0.0022	±2.5			
		1732.5	50	-6.22	-0.0036	±2.5			
	10		1732.5	-30	6.05	0.0035	±2.5		
			1732.5	-20	-6.10	-0.0035	±2.5		
			1732.5	-10	5.78	0.0033	±2.5		
			1732.5	0	5.16	0.0030	±2.5		
			1732.5	10	5.26	0.0030	±2.5		
			1732.5	20	5.12	0.0030	±2.5		
			1732.5	30	-5.16	-0.0030	±2.5		
			1732.5	40	5.40	0.0031	±2.5		
			1732.5	50	-5.21	-0.0030	±2.5		
			15		1732.5	-30	5.76	0.0069	±2.5
					1732.5	-20	-6.11	-0.0073	±2.5
					1732.5	-10	-5.74	-0.0069	±2.5
					1732.5	0	4.68	0.0056	±2.5
	1732.5	10			-5.12	-0.0061	±2.5		
	1732.5	20			4.08	0.0049	±2.5		
	1732.5	30			5.23	0.0063	±2.5		
	1732.5	40			5.89	0.0070	±2.5		
	20		1732.5	50	-4.97	-0.0059	±2.5		
			1732.5	-30	6.15	0.0035	±2.5		
			1732.5	-20	-6.10	-0.0035	±2.5		
			1732.5	-10	-5.94	-0.0034	±2.5		
			1732.5	0	5.12	0.0030	±2.5		
			1732.5	10	-4.56	-0.0026	±2.5		
			1732.5	20	4.42	0.0026	±2.5		
			1732.5	30	5.32	0.0031	±2.5		
			1732.5	40	6.19	0.0036	±2.5		
	1732.5	50	-5.15	-0.0030	±2.5				
	FDD 5	5	836.5	-30	3.78	0.0045	±2.5		
			836.5	-20	-3.42	-0.0041	±2.5		
			836.5	-10	-3.63	-0.0043	±2.5		
			836.5	0	-3.21	-0.0038	±2.5		
836.5			10	-2.49	-0.0030	±2.5			
836.5			20	3.28	0.0039	±2.5			
836.5			30	-3.01	-0.0036	±2.5			
836.5			40	-3.81	-0.0046	±2.5			
836.5			50	-2.86	-0.0034	±2.5			
10			836.5	-30	-3.37	-0.0040	±2.5		
			836.5	-20	-2.56	-0.0031	±2.5		
			836.5	-10	-3.20	-0.0038	±2.5		
			836.5	0	-2.70	-0.0032	±2.5		
			836.5	10	2.75	0.0033	±2.5		

www.tuv.com

		836.5	20	2.19	0.0026	±2.5
		836.5	30	3.01	0.0036	±2.5
		836.5	40	-3.39	-0.0041	±2.5
		836.5	50	-3.03	-0.0036	±2.5
FDD 17	5	710.0	-30	4.62	0.0065	±2.5
		710.0	-20	-4.21	-0.0059	±2.5
		710.0	-10	-4.12	-0.0058	±2.5
		710.0	0	-4.24	-0.0060	±2.5
		710.0	10	-3.12	-0.0044	±2.5
		710.0	20	4.34	0.0061	±2.5
		710.0	30	-2.86	-0.0040	±2.5
		710.0	40	-4.36	-0.0061	±2.5
		710.0	50	-3.22	-0.0045	±2.5
	10	710.0	-30	-4.78	-0.0067	±2.5
		710.0	-20	-3.42	-0.0048	±2.5
		710.0	-10	-4.13	-0.0058	±2.5
		710.0	0	-4.56	-0.0064	±2.5
		710.0	10	3.78	0.0053	±2.5
		710.0	20	2.83	0.0040	±2.5
		710.0	30	3.42	0.0048	±2.5
		710.0	40	-4.28	-0.0060	±2.5
		710.0	50	-4.57	-0.0064	±2.5
FDD 13	10	782	-30	-6.83	-0.00873	±2.5
		782	-20	-7.01	-0.00896	±2.5
		782	-10	-7.37	-0.00942	±2.5
		782	0	-6.38	-0.00816	±2.5
		782	10	-7.02	-0.00898	±2.5
		782	20	-7.42	-0.00949	±2.5
		782	30	-6.28	-0.00803	±2.5
		782	40	-6.89	-0.00881	±2.5
		782	50	-7.89	-0.01009	±2.5

www.tuv.com

RF Power (ERP/EIRP) – Radiated Mode Result

Pass

Specification FCC Part 2.1046(a), 22.913(a) (2) 24.232(c), 27.50(d) (4) & RSS 132 Issue 3 section 5.4, SRSP-503 section 5.1.3 & RSS 133 Issue 6 section 4.1/6.4, SRSP-510.5.1.2 & RSS 139 Issue 3 section 6.5 & RSS 130 Issue 1 section 4.4

Measurement Bandwidth (RBW) 100KHz/1MHz

Detector Function Peak

Requirement ≤ FDD Band 2 : 2 Watts (33 dBm)
 FDD Band 4 : 1 Watts (30 dBm)
 FDD Band 5 : 7 Watts (38.4dBm) for FCC & 11.5 Watts (40.60dBm) for IC
 FDD Band 17: 5 Watts (36.98dBm)
 FCC Band 13:

Test Setup:

Note: For measurement of RF Output Power, Test performed as per ANSI/TIA-603-D-2010 Clause 2.2.17.

Test Results

Only Worst Case test results are reported.

FDD Band	Bandwidth	Channel	Polarization	Radiated Output Power (dBm)	Limit (dBm)	Margin (dB)
2	5	Low	Vertical	22.16	33	-10.84
			Horizontal	21.14	33	-11.86
		Mid	Vertical	22.08	33	-10.92
			Horizontal	21.1	33	-11.90
		High	Vertical	22.4	33	-10.60
			Horizontal	21.2	33	-11.80
	10	Low	Vertical	21.42	33	-11.58
			Horizontal	20.11	33	-12.89
		Mid	Vertical	21.25	33	-11.75
			Horizontal	19.85	33	-13.15
		High	Vertical	21.51	33	-11.49
			Horizontal	19.61	33	-13.39
	15	Low	Vertical	20.89	33	-12.11
			Horizontal	19.88	33	-13.12
		Mid	Vertical	20.67	33	-12.33
			Horizontal	20.01	33	-12.99
		High	Vertical	20.91	33	-12.09
			Horizontal	19.79	33	-13.21
	20	Low	Vertical	20.2	33	-12.80
			Horizontal	18.87	33	-14.13
		Mid	Vertical	19.81	33	-13.19
			Horizontal	18.71	33	-14.29
		High	Vertical	19.97	33	-13.03
			Horizontal	19.19	33	-13.81

www.tuv.com

4	5	Low	Vertical	18.51	30	-11.49
			Horizontal	19.45	30	-10.55
		Mid	Vertical	20.23	30	-9.77
			Horizontal	19.55	30	-10.45
		High	Vertical	19.88	30	-10.12
			Horizontal	18.41	30	-11.59
	10	Low	Vertical	17.71	30	-12.29
			Horizontal	18.9	30	-11.1
		Mid	Vertical	18.95	30	-11.05
			Horizontal	18.24	30	-11.76
		High	Vertical	18.98	30	-11.02
			Horizontal	17.33	30	-12.67
	15	Low	Vertical	19.12	30	-10.88
			Horizontal	18.01	30	-11.99
		Mid	Vertical	18.86	30	-11.14
			Horizontal	18.23	30	-11.77
		High	Vertical	19.02	30	-10.98
			Horizontal	18.32	30	-11.68
	20	Low	Vertical	17.26	30	-12.74
			Horizontal	16.61	30	-13.39
Mid		Vertical	17.55	30	-12.45	
		Horizontal	16.77	30	-13.23	
High		Vertical	17.58	30	-12.42	
		Horizontal	16.02	30	-13.98	
5	5	Low	Vertical	17.86	38.45	-20.59
			Horizontal	12.05	38.45	-26.4
		Mid	Vertical	17.06	38.45	-21.39
			Horizontal	12.29	38.45	-26.16
		High	Vertical	16.34	38.45	-22.11
			Horizontal	12.73	38.45	-25.72
	10	Low	Vertical	18.14	38.45	-20.31
			Horizontal	15.29	38.45	-23.16
		Mid	Vertical	17.93	38.45	-20.52
			Horizontal	15.17	38.45	-23.28
		High	Vertical	17.31	38.45	-21.14
			Horizontal	14.45	38.45	-24.00
17	5	Low	Vertical	11.21	36.98	-25.77
			Horizontal	16.69	36.98	-20.29
		Mid	Vertical	16.7	36.98	-20.28
			Horizontal	16.75	36.98	-20.23
		High	Vertical	11.69	36.98	-25.29
			Horizontal	16.96	36.98	-20.02
	10	Low	Vertical	10.98	36.98	-26.00
			Horizontal	16.3	36.98	-20.68
		Mid	Vertical	11.7	36.98	-20.28

www.tuv.com

			Horizontal	16.75	36.98	-20.23
		High	Vertical	11.42	36.98	-25.56
			Horizontal	15.84	36.98	-21.14
13	10	Mid	Vertical	11.63	36.98	-25.35
			Horizontal	17.93	36.98	-19.05

www.tuv.com

**Field Strength of Spurious Radiation
Result**

Pass

Specification	FCC Part 2.1053(a), 22.917(a)(b), 24.238(a)(b) 27.53(h) & RSS 132 Issue 3 section 5.5, RSS 130 Issue 1 Section 4.6 RSS 133 Issue 6 section 6.5 (i)(ii), RSS 139 Issue 3 section 6.6(i)(ii)
Measurement Bandwidth (RBW)	100KHz/1MHz
Detector Function	Peak
Requirement	Shall be attenuated below the transmitter power (P in watt) by at least $43+10\log(P)$ dBm,

Note: For measurement of RF Output Power, Test performed as per ANSI/TIA-603-D-2010 Clause 2.2.12.

Test Results

Test Results below 1GHz

Worst case test results are reported for 1GB RAM Variant.

Polarization	Frequency (MHz)	Emission (dBm)	Limit (dBm)	Margin (dB)
Vertical	98.38	-57.05	-13	-44.05
	210.71	-58.68	-13	-45.68
Horizontal	97.6	-58.72	-13	-45.72
	213.03	-55.78	-13	-42.78

Worst case test results are reported for 2GB RAM Variant.

Polarization	Frequency (MHz)	Emission (dBm)	Limit (dBm)	Margin (dB)
Vertical	100.91	-56.84	-13	-43.84
	211.64	-57.28	-13	-44.28
Horizontal	99.27	-55.29	-13	-42.29
	210.15	-56.29	-13	-43.29

Worst Case Test Result above 1GHz

FDD Band	Channel Bandwidth (MHz)	Channel	Channel Frequency (MHz)	Polarization	Frequency (MHz)	Emission (dBm)	Limit (dBm)	Margin (dB)
2	5,10,15 & 20	Low	No Spurious Emissions were found					
		Mid						
		High						
4	5,10,15 & 20	Low	No Spurious Emissions were found					
		Mid						
		High						
5	5	Low	829	Vertical	1660.2	-40.24	-13	-27.24
				Horizontal	1659.4	-40.68	-13	-27.68
				Vertical	2490.2	-49.34	-13	-36.34
				Horizontal	2489.7	-48.98	-13	-35.98
		Mid	836.5	Vertical	1675.4	-41.64	-13	-28.64
				Horizontal	1675.2	-41.38	-13	-28.38
				Vertical	3346.2	-50.48	-13	-37.48
				Horizontal	3346.1	-49.85	-13	-36.85
		High	844	Vertical	1693.2	-38.67	-13	-25.67
				Horizontal	1693.1	-39.32	-13	-26.32
				Vertical	2532.6	-50.12	-13	-37.12
				Horizontal	2531.8	-49.78	-13	-36.78
	10	Low	826.5	Vertical	1658.1	-44.53	-13	-31.53
				Horizontal	1658.1	-44.34	-13	-31.34
				Vertical	2500.1	-47.07	-13	-34.07
				Horizontal	2500.1	-51.61	-13	-38.61
				Vertical	3316.2	-51.20	-13	-38.20
				Horizontal	3316.2	-50.89	-13	-37.89
		Mid	836.5	Vertical	1672.9	-45.33	-13	-32.33
				Horizontal	1673	-44.48	-13	-31.48
				Vertical	2500.1	-47.74	-13	-34.74
				Horizontal	2500.1	-52.14	-13	-39.14
				Vertical	1694.2	-40.12	-13	-27.12
				Horizontal	1694.5	-41.24	-13	-28.24
High	846.5	Vertical	2541.2	-48.21	-13	-35.21		
		Horizontal	2540.9	-49.43	-13	-36.43		
		Vertical	1413	-65.03	-13	-52.03		
		Horizontal	1413	-59.23	-13	-46.23		
		Vertical	2119.5	-63.26	-13	-50.26		
		Horizontal	2119.5	-62.82	-13	-49.82		
17	5	Low	706.5	Vertical	2826	-57.55	-13	-44.55
				Horizontal	2826	-55.53	-13	-42.53

				Vertical	3532.5	-57.96	-13	-44.96		
				Horizontal	3532.5	-58.93	-13	-45.93		
		Mid	710	Vertical	1420	-64.34	-13	-51.34		
				Horizontal	1420	-57.89	-13	-44.89		
				Vertical	2130	-61.97	-13	-48.97		
				Horizontal	2130	-62.09	-13	-49.09		
				Vertical	2840	-55.60	-13	-42.60		
				Horizontal	2840	-54.43	-13	-41.43		
				Vertical	3550	-57.06	-13	-44.06		
				Horizontal	3550	-57.66	-13	-44.66		
				High	713.5	Vertical	1427	-64.56	-13	-51.56
						Horizontal	1427	-58.89	-13	-45.89
		Vertical	2140.5			-62.92	-13	-49.92		
		Horizontal	2140.5			-62.73	-13	-49.73		
		Vertical	2854			-55.68	-13	-42.68		
		Horizontal	2854			-55.88	-13	-42.88		
		Vertical	3567.5			-58.50	-13	-45.50		
		Horizontal	3567.5			-57.97	-13	-44.97		
	10	Low	709	Vertical	1418	-64.92	-13	-51.92		
				Horizontal	1418	-60.01	-13	-47.01		
				Vertical	2127	-63.93	-13	-50.93		
				Horizontal	2127	-64.03	-13	-51.03		
				Vertical	2836	-58.78	-13	-45.78		
				Horizontal	2836	-56.48	-13	-43.48		
		Mid	710	Vertical	1420	-66.67	-13	-53.67		
				Horizontal	1420	-60.47	-13	-47.47		
				Vertical	2130	-64.04	-13	-51.04		
				Horizontal	2130	-63.62	-13	-50.62		
				Vertical	2840	-59.98	-13	-46.98		
				Horizontal	2840	-60.12	-13	-47.12		
		High	711	Vertical	1422	-66.25	-13	-53.25		
				Horizontal	1422	-60.73	-13	-47.73		
				Vertical	2133	-64.09	-13	-51.09		
				Horizontal	2133	-63.93	-13	-50.93		
				Vertical	2844	-61.97	-13	-48.97		
				Horizontal	2844	-60.57	-13	-47.57		
13		10	Mid	782	Vertical	1564	-65.92	-13	-52.92	
					Horizontal	1564	-63.64	-13	-50.64	

END OF TEST REPORT