



Hermon Laboratories Ltd.
Harakevet Industrial Zone, Binyamina 30500,
Israel
Tel. +972-4-6288001
Fax. +972-4-6288277
E-mail: mail@hermonlabs.com

TEST REPORT

ACCORDING TO: FCC 47 CFR PART 15 subpart C, section 15.231; subpart B and
RSS-210 issue 8 Annex 1; CES-003 Issue 5:2012

FOR:

Essence Security International Ltd.
Z-Wave extender
Model: ES800ZWE
FCC ID:YXG-ES800ZWE
IC:11061A-ES800ZWE

This report is in conformity with ISO/IEC 17025. The "A2LA Accredited" symbol endorsement applies only to the tests and calibrations that are listed in the scope of Hermon Laboratories accreditation. The test results relate only to the items tested. This test report shall not be reproduced in any form except in full with the written approval of Hermon Laboratories Ltd.

Table of contents

1	Applicant information	3
2	Equipment under test attributes	3
3	Manufacturer information	3
4	Test details	3
5	Tests summary	4
6	EUT description	5
6.1	General information	5
6.2	Ports and lines	5
6.3	Support and test equipment	5
6.4	Changes made in EUT	5
6.5	Test configuration	5
6.6	EUT test positions	6
6.7	Transmitter characteristics	7
7	Transmitter tests according to 47CFR part 15 subpart C and RSS-210 Annex 1 requirements	8
7.1	Periodic operation requirements	8
7.2	Field strength of emissions	10
7.3	Occupied bandwidth test	23
7.4	Conducted emissions	26
7.5	Antenna requirements	29
8	Unintentional emissions	30
8.1	Conducted emissions	30
8.2	Radiated emission measurements	34
9	APPENDIX A Test equipment and ancillaries used for tests	40
10	APPENDIX B Measurement uncertainties	41
11	APPENDIX C Test laboratory description	42
12	APPENDIX D Specification references	42
13	APPENDIX E Test equipment correction factors	43
14	APPENDIX F Abbreviations and acronyms	50

1 Applicant information

Client name: Essence Security International Ltd.
Address: 12 Abba Eban Avenue, Ackerstein Towers Bldg. D, P.O.B. 2073, Herzliya 4612001, Israel
Telephone: +972 73 244 7735
Fax: +972 9772 9962
E-mail: israelgo@essence-grp.com
Contact name: Mr. Israel Gottesman

2 Equipment under test attributes

Product name: Z-Wave extender
Product type: Transceiver
Model(s): ES800ZWE
Serial number: 072643
Hardware version: 2.A
Software release: serialapi_controller_static_ZW050x_US
Receipt date: 27-Jul-15

3 Manufacturer information

Manufacturer name: Essence Security International Ltd.
Address: 12 Abba Eban Avenue, Ackerstein Towers Bldg. D, P.O.B. 2073, Herzliya 4612001, Israel
Telephone: +972 73 244 7735
Fax: +972 9772 9962
E-Mail: israelgo@essence-grp.com
Contact name: Mr. Israel Gottesman

4 Test details

Project ID: 27287
Location: Hermon Laboratories Ltd. Harakevet Industrial Zone, Binyamina 30500, Israel
Test started: 27-Jul-15
Test completed: 29-Jul-15
Test specification(s): FCC 47CFR part 15, subpart C, §15.231, subpart B;
RSS-210 issue 8 Annex 1, RSS-Gen issue 4, ICES-003 issue 5:2012



5 Tests summary

Test	Status
Transmitter characteristics	
FCC Part 15, Section 231(a) / RSS-210, Section A1.1.1, Periodic operation requirements	Pass
FCC Part 15, Section 231(b) / RSS-210, Section A1.1.2, Field strength of emissions	Pass
FCC Part 15, Section 231(c) / RSS-210, Section A1.1.3, Occupied bandwidth	Pass
FCC Part 15, Section 207 / RSS-Gen, Section 8.8, Conducted emission	Pass
FCC Part 15, Section 203 / RSS-Gen, Section 8.3, Antenna requirements	Pass
Unintentional emissions	
FCC Part 15, Section 107 / CES-003, Section 6.1 class B, Conducted emission at AC power port	Pass
FCC Part 15, Section 109 / RSS-Gen, Section 7.1.2/ ICES-003, Section 6.2 class B, Radiated emission	Pass

Testing was completed against all relevant requirements of the test standard. The results obtained indicate that the product under test complies in full with the requirements tested.

The test results relate only to the items tested. Pass/ fail decision was based on nominal values.

This test report supersedes the previously issued test report identified by Doc ID:ESSRAD_FCC.27287.

	Name and Title	Date	Signature
Tested by:	Mrs. E. Pitt, test engineer	July 29, 2015	
Reviewed by:	Mrs. M. Cherniavsky, certification engineer	August 25, 2015	
Approved by:	Mrs. E. Pitt, EMC and Radio group deputy	August 25, 2015	

6 EUT description

6.1 General information

The EUT, Z-Wave extender, comprises radio and allows incorporation of 3rd party Z-Wave® compatible devices (smart home applications) with Essence security system.

6.2 Ports and lines

Port type	Port description	Connected from	Connected to	Qty.	Cable type	Cable length, m
Power	DC	AC/DC adapter	EUT	1	Unshielded	1.5
Power	AC	AC mains	AC/DC adapter		Unshielded	1.5
Signal	Signal	EUT	Control panel	1	Unshielded	0.2

6.3 Support and test equipment

Description	Manufacturer	Model number	Serial number
Control panel	Essence Security International Ltd.	ES8000WG	032751
AC/DC adapter	DVE	DSA-6PFE-05 FEU	050100

6.4 Changes made in EUT

No changes were implemented in the EUT during the testing.

6.5 Test configuration

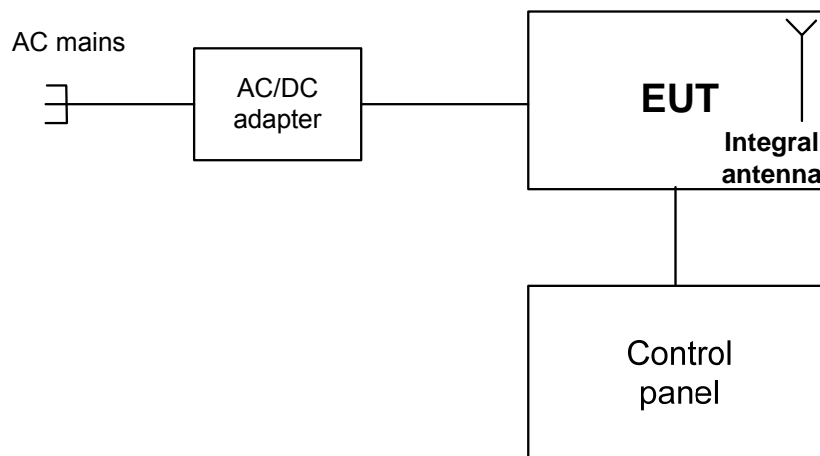

6.6 EUT test positions

Photograph 6.6.1 EUT in X-axis orthogonal position



Photograph 6.6.2 EUT in Y-axis orthogonal position



Photograph 6.6.3 EUT in Z-axis orthogonal position





6.7 Transmitter characteristics

Type of equipment						
	Stand-alone (Equipment with or without its own control provisions)					
X	Combined equipment (Equipment where the radio part is fully integrated within another type of equipment)					
	Plug-in card (Equipment intended for a variety of host systems)					
Operating frequency		908.4 MHz				
Maximum rated output power		At transmitter 50 Ω RF output connector			dBm	
		Field strength at 3 m distance			101 dB(μV/m) – peak, 78.5 dB(μV/m) - average	
Is transmitter output power variable?		X	No			
		Yes		continuous variable		
				stepped variable with stepsize		dB
			minimum RF power			dBm
			maximum RF power			dBm
Antenna connection						
	unique coupling		standard connector	X	integral	
					X	
		with temporary RF connector				
		without temporary RF connector				
Type of modulation		FSK				
Transmitter aggregate data rate/s		40 kbps				
Transmitter power source						
	Battery	Nominal rated voltage	VDC			
	DC	Nominal rated voltage	VDC			
X	AC mains	Nominal rated voltage	120 VAC via AC/5VDC adapter	Frequency 60 Hz		
Common power source for transmitter and receiver				X	yes	no



Test specification:	FCC Part 15, Section 231(a) / RSS-210, Section A1.1.1, Periodic operation requirements		
Test procedure:	Supplier declaration		
Test mode:	Compliance	Verdict:	PASS
Date(s):	28-Jul-15		
Temperature: 24 °C	Air Pressure: 1004 hPa	Relative Humidity: 41 %	Power Supply: 120 VAC
Remarks:			

7 Transmitter tests according to 47CFR part 15 subpart C and RSS-210 Annex 1 requirements

7.1 Periodic operation requirements

7.1.1 General

The EUT was verified for compliance with periodic operation requirements listed below:

- Continuous transmissions such as voice, video and the radio control of toys are not permitted;
- A manually operated transmitter shall employ switch that will automatically deactivate the transmitter within not more than 5 seconds of being released;
- A transmitter activated automatically shall cease transmission within 5 seconds after activation;
- Periodic transmissions, excluding polling or supervision transmissions, at regular predetermined intervals are not permitted;
- Total duration of polling or supervision transmissions, including data, to determine system integrity in security or safety applications shall not exceed 2 seconds per hour;
- Transmission of set-up information for security systems may exceed the transmission duration limits of 5 seconds, provided such transmissions are under the control of a professional installer and do not exceed ten seconds after a manually operated switch is released or a transmitter is activated automatically. Such set-up information may include data.

The rationale for compliance with the above requirements was either test results or supplier declaration. The summary of results is provided in Table 7.1.1.

7.1.2 Test procedure for transmitter shut down test

7.1.2.1 The EUT was set up as shown in Figure 7.1.1.

7.1.2.2 The spectrum analyzer center frequency was adjusted to the EUT carrier, span set to zero and video triggered for transmission.

7.1.2.3 The transmitter was activated either manually or automatically. Once manually operated transmitter was activated, the switch was immediately released.

7.1.2.4 The transmission time was captured and shown in Plot 7.1.1.

Figure 7.1.1 Setup for transmitter shut down test





Test specification:	FCC Part 15, Section 231(a) / RSS-210, Section A1.1.1, Periodic operation requirements		
Test procedure:	Supplier declaration		
Test mode:	Compliance	Verdict: PASS	
Date(s):	28-Jul-15		
Temperature: 24 °C	Air Pressure: 1004 hPa	Relative Humidity: 41 %	Power Supply: 120 VAC
Remarks:			

Table 7.1.1 Periodic operation requirements

Requirement	Rationale	Verdict
Continuous transmissions are not permitted	Supplier declaration	Comply
A manually operated transmitter shall be deactivated within not more than 5 seconds of switch being released	NA	NA
Transmitter activated automatically shall cease transmission within 5 seconds	Plot 7.1.1	Comply
Periodic transmissions at regular predetermined intervals are not permitted	Supplier declaration	Comply
Total duration of polling or supervision transmissions shall not exceed 2 seconds per hour	NA	NA
Transmission of set-up information for security systems may exceed the transmission duration limits of 5 seconds, provided such transmissions are under the control of a professional installer and do not exceed ten seconds after a manually operated switch is released or a transmitter is activated automatically. Such set-up information may include data.	NA	NA

Plot 7.1.1 Transmitter shut down test result

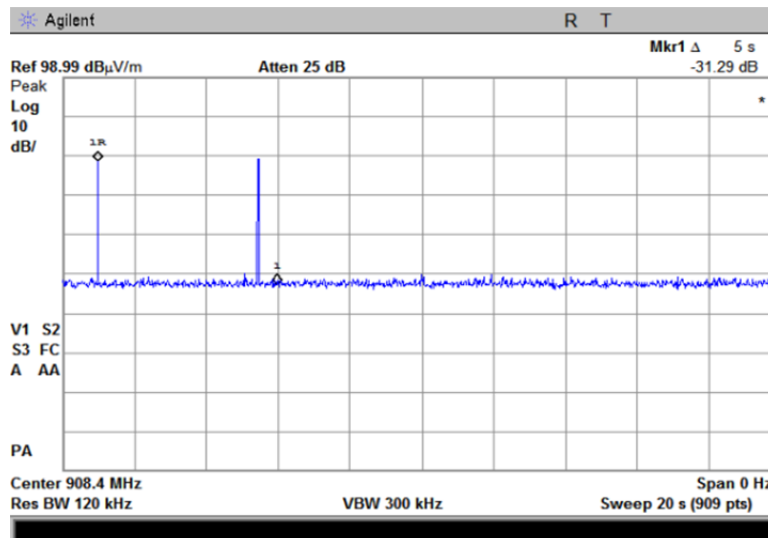

Reference numbers of test equipment used

HL 0521						
---------	--	--	--	--	--	--

Full description is given in Appendix A.



Test specification:	FCC Part 15, Section 231(b) / RSS-210, Section A1.1.2, Field strength of emissions		
Test procedure:	ANSI C63.4, Section 13.1.4		
Test mode:	Compliance	Verdict:	PASS
Date(s):	27-Jul-15		
Temperature: 23 °C	Air Pressure: 1005 hPa	Relative Humidity: 44 %	Power Supply: 120 VAC
Remarks:			

7.2 Field strength of emissions

7.2.1 General

This test was performed to measure field strength of fundamental and spurious emissions from the EUT. Specification test limits are given in Table 7.2.1 and Table 7.2.2.

Table 7.2.1 Radiated fundamental emission limits

Fundamental frequency, MHz	Field strength at 3 m, dB(μV/m)	
	Peak	Average
908.4	102	82

Table 7.2.2 Radiated spurious emissions limits

Frequency, MHz	Field strength at 3 m, dB(μV/m)				
	Within restricted bands			Outside restricted bands	
	Peak	Quasi Peak	Average	Peak	Average
0.009 – 0.090	148.5 – 128.5	NA	128.5 – 108.5**	82	62
0.090 – 0.110	NA	108.5 – 106.8**	NA		
0.110 – 0.490	126.8 – 113.8	NA	106.8 – 93.8**		
0.490 – 1.705	NA	73.8 – 63.0**	NA		
1.705 – 30.0*		69.5			
30 – 88		40.0			
88 – 216		43.5			
216 – 960		46.0			
960 - 1000		54.0			
Above 1000	74.0	NA	54.0		

*- The limit for 3 m test distance was calculated using the inverse square distance extrapolation factor as follows:

$$Lim_{S_2} = Lim_{S_1} + 40 \log (S_1/S_2),$$

where S_1 and S_2 – standard defined and test distance respectively in meters.

** - The limit decreases linearly with the logarithm of frequency.

Note 1: The fundamental emission limit in dB(μV/m) was calculated as follows:

$$Lim_{AVR} = 20 \times \log(56.81818 \times F - 6136.3636) \text{ - within } 130 - 174 \text{ MHz band;}$$

$$Lim_{AVR} = 20 \times \log(41.6667 \times F - 7083.3333) \text{ - within } 260 - 470 \text{ MHz band,}$$

where F is the carrier frequency in MHz.

The limit for spurious emissions was 20 dB lower than fundamental emission limit.

The above limits provided in terms of average values, peak limit was 20 dB above the average limit.

Note 2: The above field strength limits applied from the lowest radio frequency generated in the device, without going below 9 kHz up to the tenth harmonic of the highest fundamental frequency.



Test specification:	FCC Part 15, Section 231(b) / RSS-210, Section A1.1.2, Field strength of emissions		
Test procedure:	ANSI C63.4, Section 13.1.4		
Test mode:	Compliance	Verdict:	PASS
Date(s):	27-Jul-15		
Temperature: 23 °C	Air Pressure: 1005 hPa	Relative Humidity: 44 %	Power Supply: 120 VAC
Remarks:			

7.2.2 Test procedure for spurious emission field strength measurements in 9 kHz to 30 MHz band

7.2.2.1 The EUT was set up as shown in Figure 7.2.1, energized and the performance check was conducted.

7.2.2.2 The measurements were performed in three EUT orthogonal positions.

7.2.2.3 The specified frequency range was investigated with antenna connected to spectrum analyzer/ EMI receiver. To find maximum radiation the turntable was rotated 360° and the measuring antenna was rotated around its vertical axis.

7.2.2.4 The worst test results (the lowest margins) were recorded in Table 7.2.3, Table 7.2.5 and shown in the associated plots.

7.2.3 Test procedure for spurious emission field strength measurements above 30 MHz

7.2.3.1 The EUT was set up as shown in Figure 7.2.2, energized and the performance check was conducted.

7.2.3.2 The measurements were performed in three EUT orthogonal positions.

7.2.3.3 The specified frequency range was investigated with antenna connected to spectrum analyzer/ EMI receiver. To find maximum radiation the turntable was rotated 360°, the measuring antenna height was changed from 1 to 4 m, its polarization was switched from vertical to horizontal.

7.2.3.4 The worst test results (the lowest margins) were recorded in Table 7.2.3, Table 7.2.5 and shown in the associated plots.

Figure 7.2.1 Setup for spurious emission field strength measurements below 30 MHz

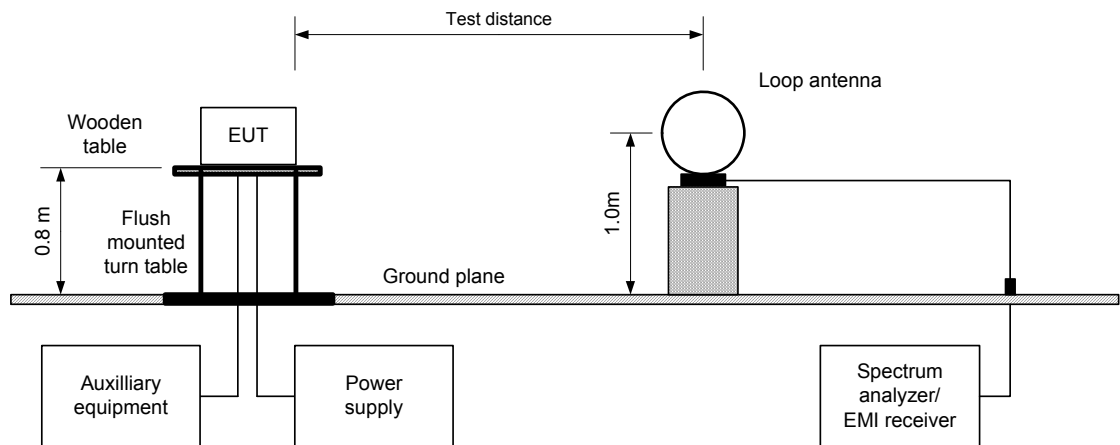



Test specification:	FCC Part 15, Section 231(b) / RSS-210, Section A1.1.2, Field strength of emissions		
Test procedure:	ANSI C63.4, Section 13.1.4		
Test mode:	Compliance	Verdict:	PASS
Date(s):	27-Jul-15		
Temperature: 23 °C	Air Pressure: 1005 hPa	Relative Humidity: 44 %	Power Supply: 120 VAC
Remarks:			

Figure 7.2.2 Setup for spurious emission field strength measurements above 30 MHz

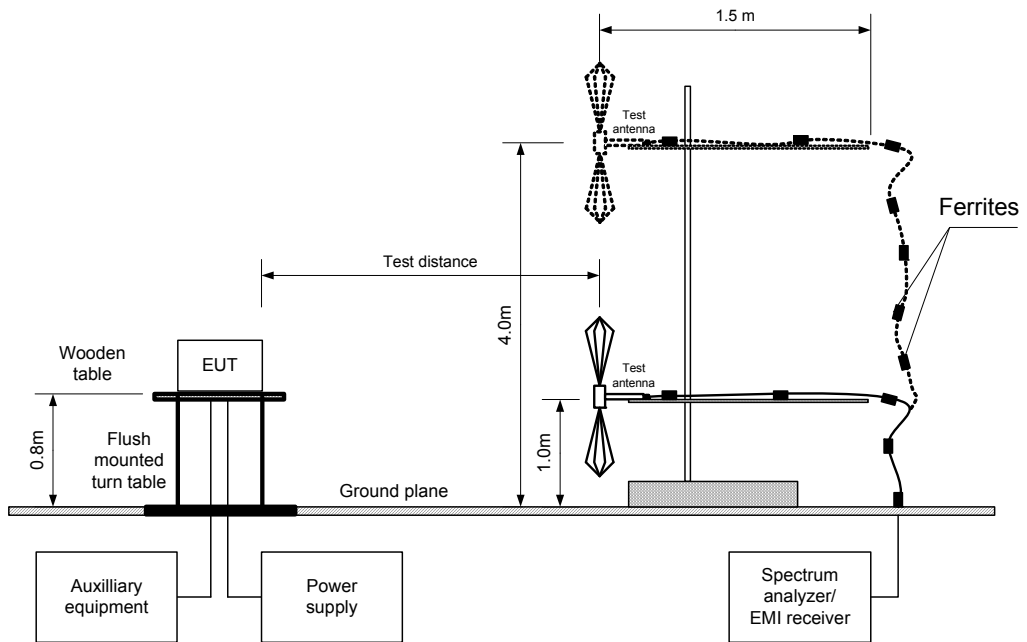



Test specification:	FCC Part 15, Section 231(b) / RSS-210, Section A1.1.2, Field strength of emissions		
Test procedure:	ANSI C63.4, Section 13.1.4		
Test mode:	Compliance	Verdict: PASS	
Date(s):	27-Jul-15		
Temperature: 23 °C	Air Pressure: 1005 hPa	Relative Humidity: 44 %	Power Supply: 120 VAC
Remarks:			

Table 7.2.3 Field strength of fundamental emission, spurious emissions outside restricted bands and within restricted bands at frequencies above 1 GHz

TEST DISTANCE: 3 m
 EUT POSITION: 3 orthogonal (X / Y / Z)
 MODULATION: FSK
 BIT RATE: 40 kbps
 INVESTIGATED FREQUENCY RANGE: 0.009 - 9100 MHz
 DETECTOR USED: Peak
 RESOLUTION BANDWIDTH: 1.0 kHz (9 kHz – 150 kHz)
 9.0 kHz (150 kHz – 30 MHz)
 120 kHz (30 MHz – 1000 MHz)
 1.0 MHz (above 1000 MHz)
 VIDEO BANDWIDTH: ≥ Resolution bandwidth
 TEST ANTENNA TYPE: Active loop (9 kHz – 30 MHz)
 Biconilog (30 MHz – 1000 MHz)
 Double ridged guide (above 1000 MHz)

F, MHz	Antenna		Azimuth, degrees*	Peak field strength			Average field strength				Verdict
	Pol.	Height, m		Measured, dB(μV/m)	Limit, dB(μV/m)	Margin, dB**	Measured, dB(μV/m)	Calculated, dB(μV/m)	Limit, dB(μV/m)	Margin, dB**	
Fundamental emission***											
908.4	H	1.4	40	101.1	102	-0.9	101.1	78.5	82	-3.5	Pass
Spurious emissions											
1816.8	V	1.1	0	42.4	82	-39.6	42.4	19.8	62	-42.2	Pass
2725.2	H	1.2	20	40.2	74	-33.8	40.2	17.6	54	-36.4	
4542.0	H	1.2	45	43.2	74	-30.8	43.2	20.6	54	-33.4	
8175.6	V	1.5	180	47.9	74	-26.1	41.9	19.3	54	-34.7	

*- EUT front panel refers to 0 degrees position of turntable.

** - Margin, dB = Measured (calculated) value, dB(μV/m) - Limit, dB(μV/m)

Table 7.2.4 Average factor calculation

Transmission pulse		Transmission burst		Transmission train duration, ms	Average factor, dB
Duration, ms	Number pulse within 100 msec	Duration, ms	Period, ms		
7.4	1	NA	NA	NA	-22.6

*- Average factor was calculated as follows

for pulse train shorter than 100 ms:

$$Average\ factor = 20 \times \log_{10} \left(\frac{Pulse\ duration}{Pulse\ period} \times \frac{Burst\ duration}{Train\ duration} \times Number\ of\ bursts\ within\ pulse\ train \right)$$

for pulse train longer than 100 ms:

$$Average\ factor = 20 \times \log_{10} \left(\frac{Pulse\ duration}{Pulse\ period} \times \frac{Burst\ duration}{100\ ms} \times Number\ of\ bursts\ within\ 100\ ms \right)$$



Test specification:	FCC Part 15, Section 231(b) / RSS-210, Section A1.1.2, Field strength of emissions		
Test procedure:	ANSI C63.4, Section 13.1.4		
Test mode:	Compliance	Verdict: PASS	
Date(s):	27-Jul-15		
Temperature: 23 °C	Air Pressure: 1005 hPa	Relative Humidity: 44 %	Power Supply: 120 VAC
Remarks:			

Table 7.2.5 Field strength of emissions below 1 GHz within restricted bands

TEST DISTANCE: 3 m
EUT POSITION: 3 orthogonal (X / Y / Z)
MODULATION: FSK
BIT RATE: 40 kbps
INVESTIGATED FREQUENCY RANGE: 0.009 – 1000 MHz
DETECTOR USED: Peak
RESOLUTION BANDWIDTH: 1.0 kHz (9 kHz – 150 kHz)
9.0 kHz (150 kHz – 30 MHz)
120 kHz (30 MHz – 1000 MHz)
VIDEO BANDWIDTH: ≥ Resolution bandwidth
TEST ANTENNA TYPE: Active loop (9 kHz – 30 MHz)
Biconilog (30 MHz – 1000 MHz)

Frequency, MHz	Peak emission, dB(μV/m)	Quasi-peak			Antenna polarization	Antenna height, m	Turn-table position**, degrees	Verdict
		Measured emission, dB(μV/m)	Limit, dB(μV/m)	Margin, dB*				
150.0	29.2	28.6	43.5	-14.9	Vertical	1.0	160	Pass
972.2	34.2	33.8	54.0	-20.2	Horizontal	1.4	170	

*- Margin = Measured emission - specification limit.

**- EUT front panel refer to 0 degrees position of turntable.

Reference numbers of test equipment used

HL 0446	HL 0521	HL 0604	HL 2432	HL 2780	HL 4353	HL 4722	
---------	---------	---------	---------	---------	---------	---------	--

Full description is given in Appendix A.



Test specification:	FCC Part 15, Section 231(b) / RSS-210, Section A1.1.2, Field strength of emissions				
Test procedure:	ANSI C63.4, Section 13.1.4				
Test mode:	Compliance	Verdict:		PASS	
Date(s):	27-Jul-15				
Temperature: 23 °C	Air Pressure: 1005 hPa	Relative Humidity: 44 %	Power Supply: 120 VAC		
Remarks:					

Table 7.2.6 Restricted bands according to FCC 15, Section 205

MHz	MHz	MHz	MHz	MHz	GHz
0.09 - 0.11	8.37625 - 8.38675	73 - 74.6	399.9 - 410	2690 - 2900	10.6 - 12.7
0.495 - 0.505	8.41425 - 8.41475	74.8 - 75.2	608 - 614	3260 - 3267	13.25 - 13.4
2.1735 - 2.1905	12.290 - 12.293	108 - 121.94	960 - 1240	3332 - 3339	14.47 - 14.5
4.125 - 4.128	12.51975 - 12.52025	123 - 138	1300 - 1427	3345.8 - 3358	15.35 - 16.2
4.17725 - 4.17775	12.57675 - 12.57725	149.9 - 150.05	1435 - 1626.5	3600 - 4400	17.7 - 21.4
4.20725 - 4.20775	13.36 - 13.41	156.52475 - 156.52525	1645.5 - 1646.5	4500 - 5150	22.01 - 23.12
6.215 - 6.218	16.420 - 16.423	156.7 - 156.9	1660 - 1710	5350 - 5460	23.6 - 24
6.26775 - 6.26825	16.69475 - 16.69525	162.0125 - 167.17	1718.8 - 1722.2	7250 - 7750	31.2 - 31.8
6.31175 - 6.31225	16.80425 - 16.80475	167.72 - 173.2	2200 - 2300	8025 - 8500	36.43 - 36.5
8.291 - 8.294	25.5 - 25.67	240 - 285	2310 - 2390	9000 - 9200	Above 38.6
8.362 - 8.366	37.5 - 38.25	322 - 335.4	2483.5 - 2500	9300 - 9500	

Table 7.2.7 Restricted bands according to RSS-Gen, Table 3

MHz	MHz	MHz	MHz	MHz	GHz
0.09 - 0.11	8.291 - 8.294	16.80425 - 16.80475	399.9 - 410	3260 - 3267	10.6 - 12.7
2.1735 - 2.190	8.362 - 8.366	25.5 - 25.67	608 - 614	3332 - 3339	13.25 - 13.4
3.020 - 3.026	8.37625 - 8.38675	37.5 - 38.25	960 - 1427	3345.8 - 3358	14.47 - 14.5
4.125 - 4.128	8.41425 - 8.41475	73 - 74.6	1435 - 1626.5	3500 - 4400	15.35 - 16.2
4.17725 - 4.17775	12.290 - 12.293	74.8 - 75.2	1645.5 - 1646.5	4500 - 5150	17.7 - 21.4
4.20725 - 4.20775	12.51975 - 12.52025	108 - 138	1660 - 1710	5350 - 5460	22.01 - 23.12
5.677 - 5.683	12.57675 - 12.57725	156.52475 - 156.52525	1718.8 - 1722.2	7250 - 7750	23.6 - 24.0
6.215 - 6.218	13.36 - 13.41	156.7 - 156.9	2200 - 2300	8025 - 8500	31.2 - 31.8
6.26775 - 6.26825	16.42 - 16.423	240 - 285	2310 - 2390	9000 - 9200	36.43 - 36.5
6.31175 - 6.31225	16.69475 - 16.69525	322 - 335.4	2655 - 2900	9300 - 9500	Above 38.6



HERMON LABORATORIES

Test specification:	FCC Part 15, Section 231(b) / RSS-210, Section A1.1.2, Field strength of emissions		
Test procedure:	ANSI C63.4, Section 13.1.4		
Test mode:	Compliance	Verdict:	PASS
Date(s):	27-Jul-15		
Temperature: 23 °C	Air Pressure: 1005 hPa	Relative Humidity: 44 %	Power Supply: 120 VAC
Remarks:			

Plot 7.2.1 Radiated emission measurements at the fundamental frequency

TEST SITE: Semi anechoic chamber
 TEST DISTANCE: 3 m
 ANTENNA POLARIZATION: Vertical
 EUT POSITION: 3 orthogonal (X/ Y/ Z)

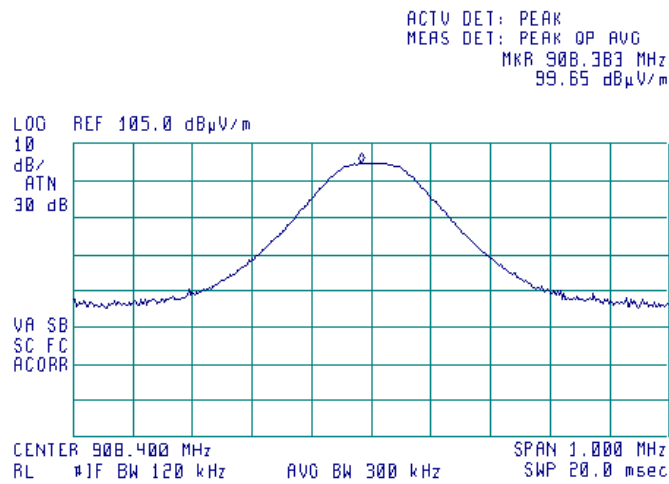

Plot 7.2.2 Radiated emission measurements at the fundamental frequency

TEST SITE: Semi anechoic chamber
 TEST DISTANCE: 3 m
 ANTENNA POLARIZATION: Horizontal
 EUT POSITION: 3 orthogonal (X/ Y/ Z)

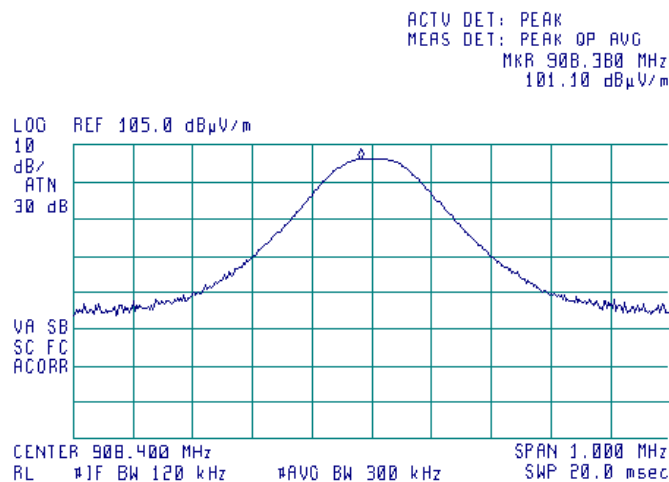



Test specification:	FCC Part 15, Section 231(b) / RSS-210, Section A1.1.2, Field strength of emissions		
Test procedure:	ANSI C63.4, Section 13.1.4		
Test mode:	Compliance	Verdict:	PASS
Date(s):	27-Jul-15		
Temperature: 23 °C	Air Pressure: 1005 hPa	Relative Humidity: 44 %	Power Supply: 120 VAC
Remarks:			

Plot 7.2.3 Radiated emission measurements from 9 to 150 kHz

TEST SITE: Anechoic chamber
 TEST DISTANCE: 3 m
 ANTENNA POLARIZATION: Vertical
 EUT POSITION: Z-axis

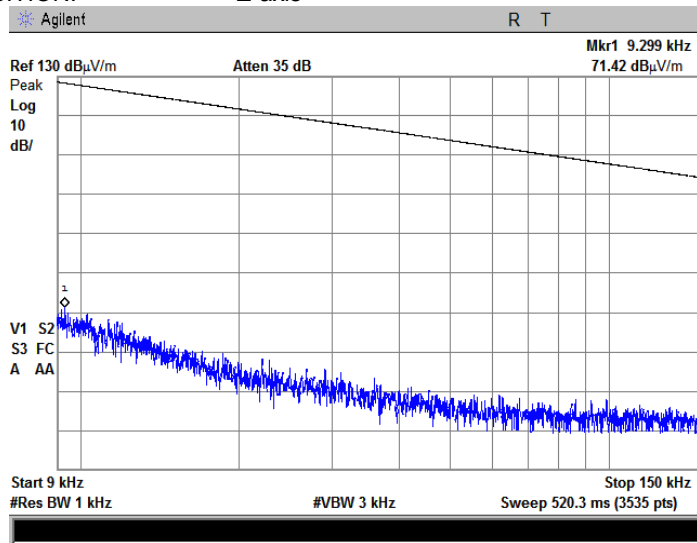

Plot 7.2.4 Radiated emission measurements from 0.15 to 30 MHz

TEST SITE: Anechoic chamber
 TEST DISTANCE: 3 m
 ANTENNA POLARIZATION: Vertical
 EUT POSITION: Z-axis

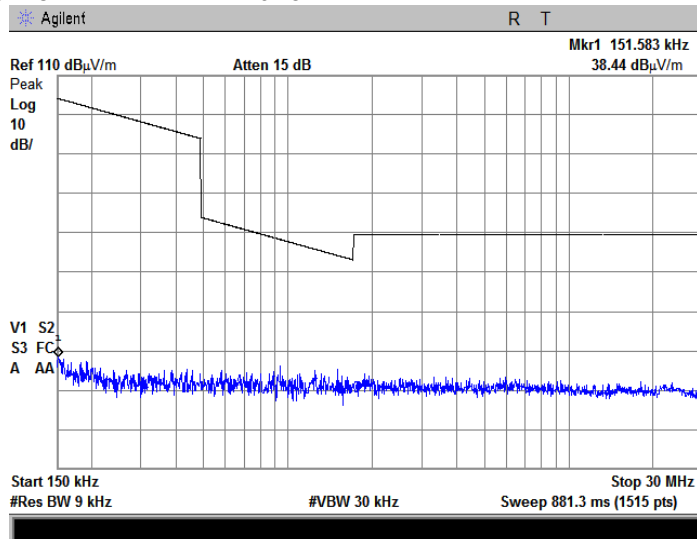



HERMON LABORATORIES

Test specification: FCC Part 15, Section 231(b) / RSS-210, Section A1.1.2, Field strength of emissions			
Test procedure: ANSI C63.4, Section 13.1.4			
Test mode: Compliance	Verdict: PASS		
Date(s): 27-Jul-15			
Temperature: 23 °C	Air Pressure: 1005 hPa	Relative Humidity: 44 %	Power Supply: 120 VAC
Remarks:			

Plot 7.2.5 Radiated emission measurements from 30 to 1000 MHz

TEST SITE: Semi anechoic chamber
 TEST DISTANCE: 3 m
 ANTENNA POLARIZATION: Vertical
 EUT POSITION: Z-axis

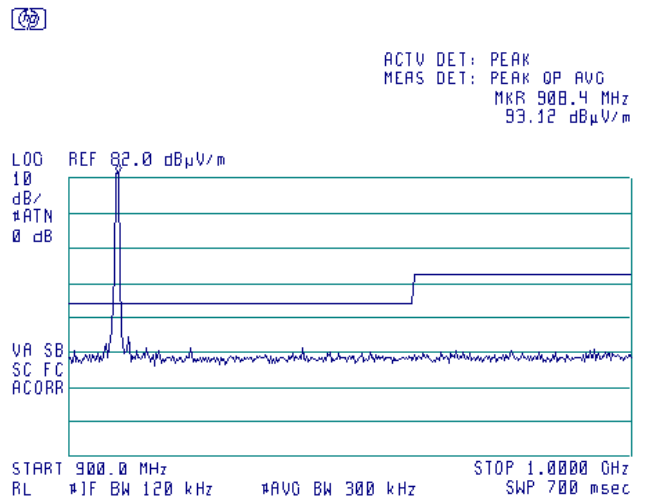
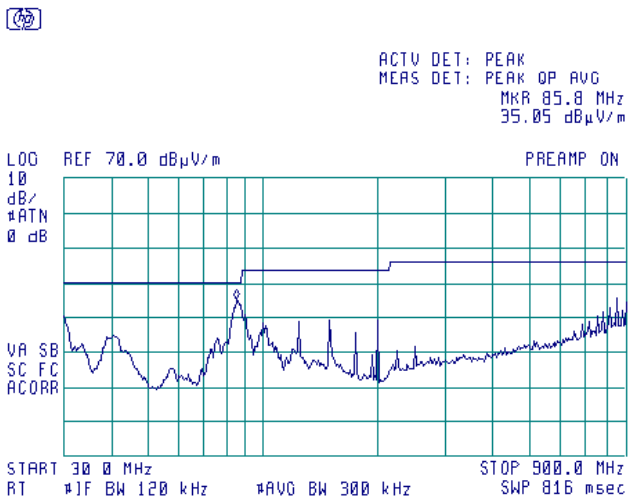

Plot 7.2.6 Radiated emission measurements from 30 to 1000 MHz

TEST SITE: Semi anechoic chamber
 TEST DISTANCE: 3 m
 ANTENNA POLARIZATION: Horizontal
 EUT POSITION: Z-axis

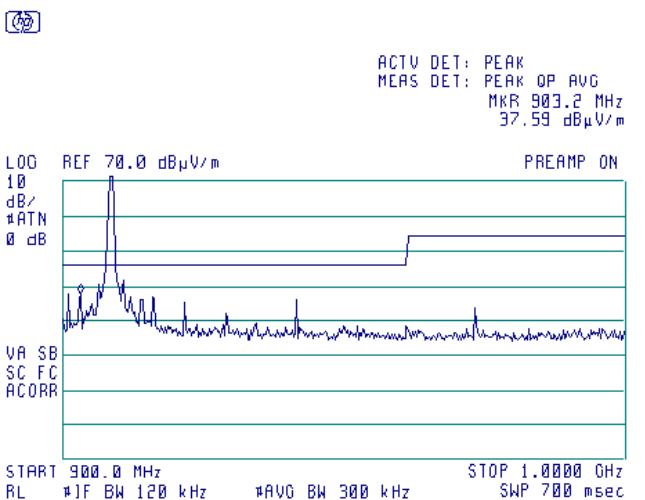
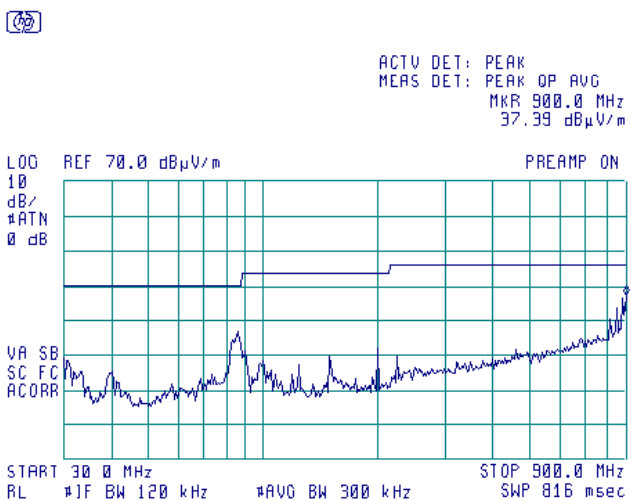



HERMON LABORATORIES

Test specification:	FCC Part 15, Section 231(b) / RSS-210, Section A1.1.2, Field strength of emissions		
Test procedure:	ANSI C63.4, Section 13.1.4		
Test mode:	Compliance	Verdict: PASS	
Date(s):	27-Jul-15		
Temperature: 23 °C	Air Pressure: 1005 hPa	Relative Humidity: 44 %	Power Supply: 120 VAC
Remarks:			

Plot 7.2.7 Radiated emission measurements from 1000 to 9100 MHz

TEST SITE: Anechoic chamber
TEST DISTANCE: 3 m
ANTENNA POLARIZATION: Vertical and Horizontal
EUT POSITION: Z-axis

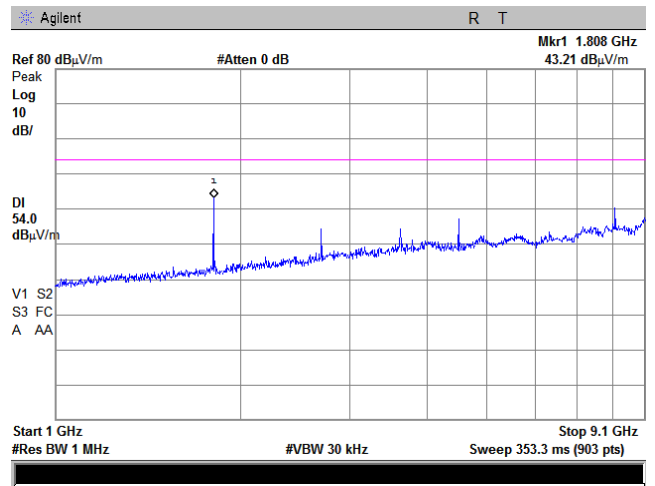
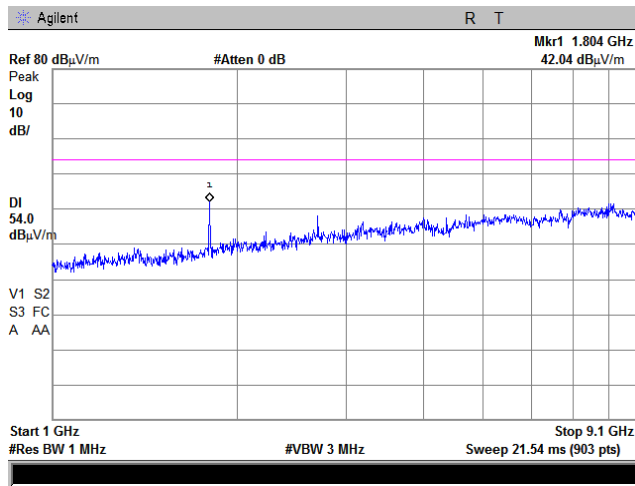



HERMON LABORATORIES

Test specification:	FCC Part 15, Section 231(b) / RSS-210, Section A1.1.2, Field strength of emissions		
Test procedure:	ANSI C63.4, Section 13.1.4		
Test mode:	Compliance	Verdict:	PASS
Date(s):	27-Jul-15		
Temperature: 23 °C	Air Pressure: 1005 hPa	Relative Humidity: 44 %	Power Supply: 120 VAC
Remarks:			

Plot 7.2.8 Radiated emission measurements at the second harmonic frequency

TEST SITE: Semi anechoic chamber
TEST DISTANCE: 3 m
ANTENNA POLARIZATION: Vertical & Horizontal
EUT POSITION: Z-axis

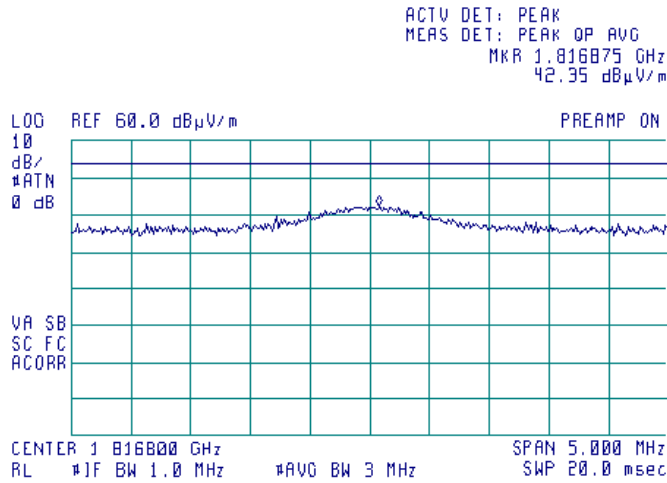

Plot 7.2.9 Radiated emission measurements at the third harmonic frequency

TEST SITE: Semi anechoic chamber
TEST DISTANCE: 3 m
ANTENNA POLARIZATION: Vertical & Horizontal
EUT POSITION: Z-axis

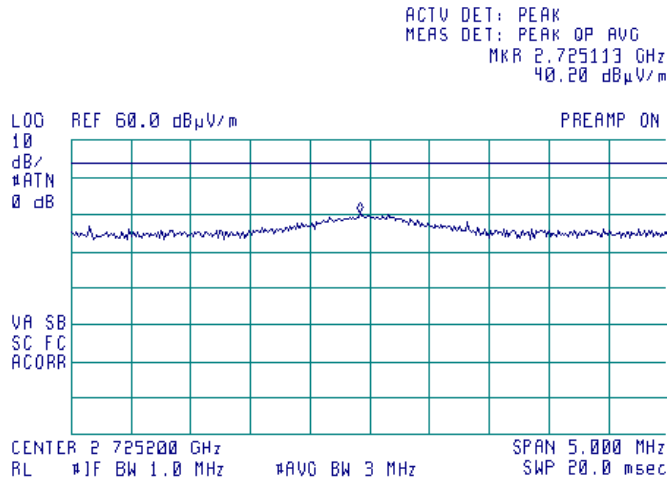



HERMON LABORATORIES

Test specification:	FCC Part 15, Section 231(b) / RSS-210, Section A1.1.2, Field strength of emissions		
Test procedure:	ANSI C63.4, Section 13.1.4		
Test mode:	Compliance	Verdict: PASS	
Date(s):	27-Jul-15		
Temperature: 23 °C	Air Pressure: 1005 hPa	Relative Humidity: 44 %	Power Supply: 120 VAC
Remarks:			

Plot 7.2.10 Radiated emission measurements at the fifth harmonic frequency

TEST SITE: Semi anechoic chamber
TEST DISTANCE: 3 m
ANTENNA POLARIZATION: Vertical & Horizontal
EUT POSITION: Z-axis

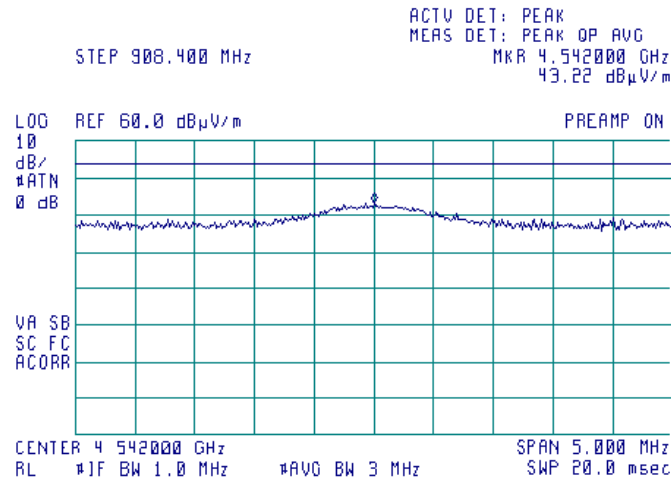

Plot 7.2.11 Radiated emission measurements at the ninth harmonic frequency

TEST SITE: Semi anechoic chamber
TEST DISTANCE: 3 m
ANTENNA POLARIZATION: Vertical & Horizontal
EUT POSITION: Z-axis

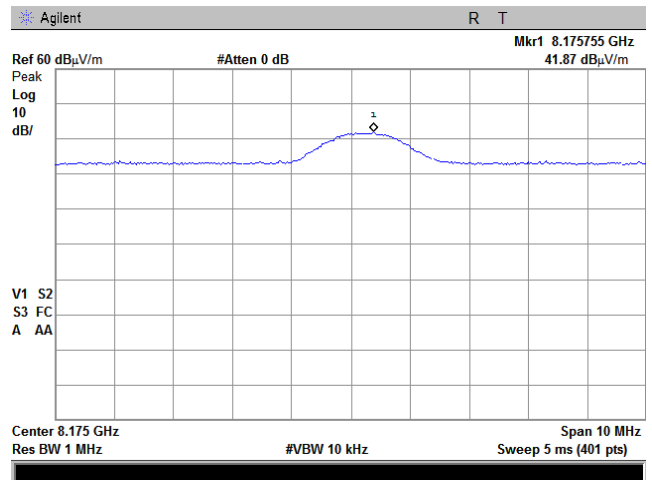
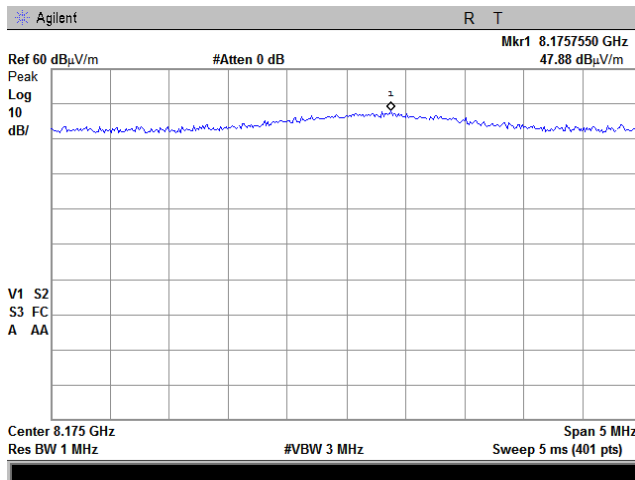



Test specification:	FCC Part 15, Section 231(b) / RSS-210, Section A1.1.2, Field strength of emissions		
Test procedure:	ANSI C63.4, Section 13.1.4		
Test mode:	Compliance	Verdict:	PASS
Date(s):	27-Jul-15		
Temperature: 23 °C	Air Pressure: 1005 hPa	Relative Humidity: 44 %	Power Supply: 120 VAC
Remarks:			

Plot 7.2.12 Transmission pulse duration

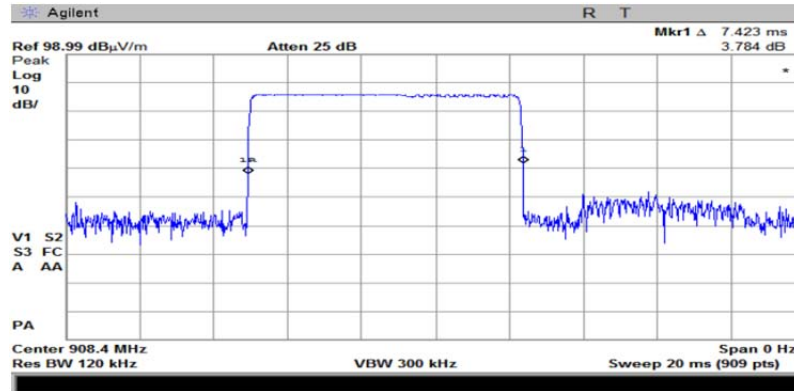

Plot 7.2.13 Transmission pulse period

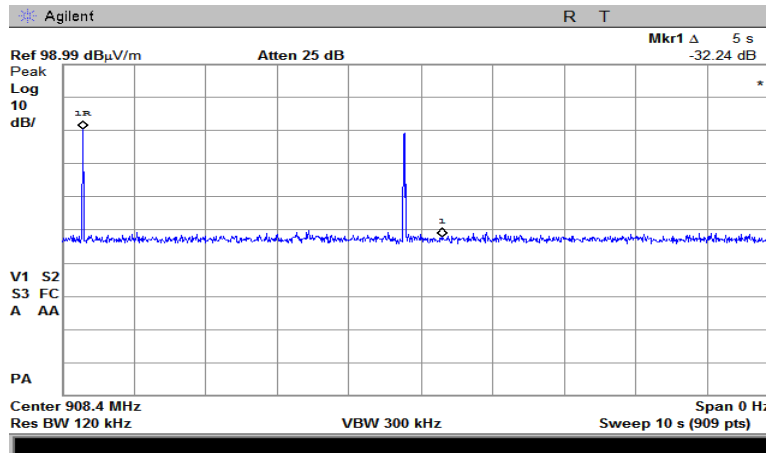



Test specification:	FCC Part 15, Section 231(c) / RSS-210, Section A1.1.3, Occupied bandwidth		
Test procedure:	ANSI C63.4, Section 13.1.7		
Test mode:	Compliance	Verdict:	PASS
Date(s):	28-Jul-15		
Temperature: 24 °C	Air Pressure: 1005 hPa	Relative Humidity: 45 %	Power Supply: 120 VAC
Remarks:			

7.3 Occupied bandwidth test

7.3.1 General

This test was performed to measure transmitter occupied bandwidth. Specification test limits are given in Table 7.3.1.

Table 7.3.1 Occupied bandwidth limits

Assigned frequency, MHz	Modulation envelope reference points*, dBc	Maximum allowed bandwidth, % of the carrier frequency
70 - 900	20.0	0.25
Above 900		0.50

*- Modulation envelope reference points provided in terms of attenuation below modulated carrier.

7.3.2 Test procedure

7.3.2.1 The EUT was set up as shown in Figure 7.3.1, energized and its proper operation was checked.

7.3.2.2 The EUT was set to transmit modulated carrier.

7.3.2.3 The transmitter occupied bandwidth was measured with spectrum analyzer as frequency delta between reference points on modulation envelope and provided in Table 7.3.2 and associated plot.

Figure 7.3.1 Occupied bandwidth test setup





Test specification:	FCC Part 15, Section 231(c) / RSS-210, Section A1.1.3, Occupied bandwidth		
Test procedure:	ANSI C63.4, Section 13.1.7		
Test mode:	Compliance	Verdict:	PASS
Date(s):	28-Jul-15		
Temperature: 24 °C	Air Pressure: 1005 hPa	Relative Humidity: 45 %	Power Supply: 120 VAC
Remarks:			

Table 7.3.2 Occupied bandwidth test results

DETECTOR USED: Peak hold
 RESOLUTION BANDWIDTH: 10 kHz
 VIDEO BANDWIDTH: 300 kHz
 MODULATION ENVELOPE REFERENCE POINTS: 20 dBc
 MODULATION: FSK
 BIT RATE: 40 kbps

MODULATION ENVELOPE REFERENCE POINTS: 20 dBc

Carrier frequency, MHz	Occupied bandwidth, kHz	Limit		Margin, kHz	Verdict
		% of the carrier frequency	kHz		
908.4	78.3	0.5	4542	-4463.7	Pass

MODULATION ENVELOPE REFERENCE POINTS: 99 %

Carrier frequency, MHz	Occupied bandwidth, kHz	Limit		Margin, kHz	Verdict
		% of the carrier frequency	kHz		
908.4	66.4	0.5	4542	-4475.6	Pass

Reference numbers of test equipment used

HL 3818								
---------	--	--	--	--	--	--	--	--

Full description is given in Appendix A.



HERMON LABORATORIES

Test specification: FCC Part 15, Section 231(c) / RSS-210, Section A1.1.3, Occupied bandwidth			
Test procedure: ANSI C63.4, Section 13.1.7			
Test mode: Compliance	Verdict: PASS		
Date(s): 28-Jul-15			
Temperature: 24 °C	Air Pressure: 1005 hPa	Relative Humidity: 45 %	Power Supply: 120 VAC
Remarks:			

Plot 7.3.1 Occupied bandwidth test result

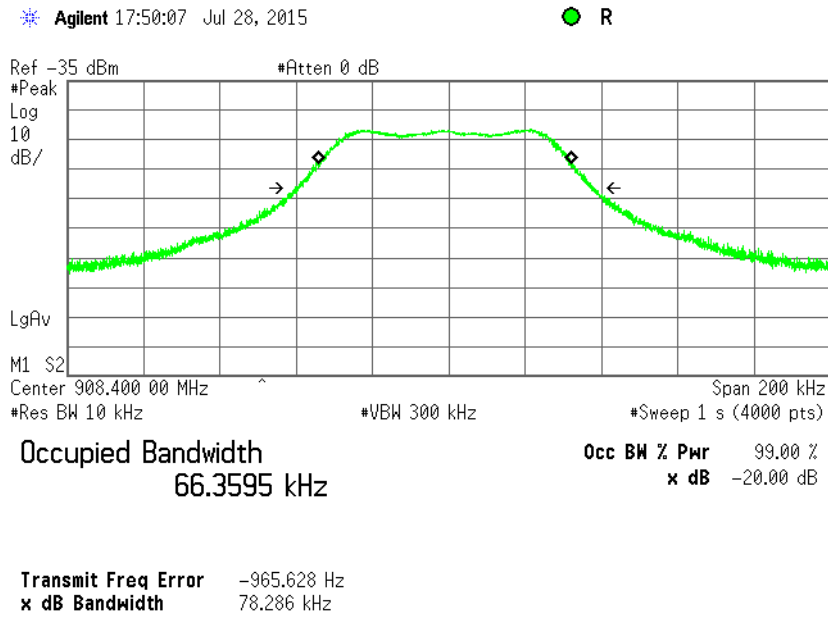



Test specification:		FCC Part 15, Section 207 / RSS-Gen, Section 7.2.2, Conducted emission	
Test procedure:		ANSI C63.4, Section 13.1.3	
Test mode:		Compliance	
Date(s):		28-Jul-15	
Temperature: 24 °C		Air Pressure: 1004 hPa	
Relative Humidity: 45 %		Power Supply: 120 VAC	
Remarks:			

7.4 Conducted emissions

7.4.1 General

This test was performed to measure common mode conducted emissions at the EUT power port. The specification test limits are given in Table 7.4.1.

Table 7.4.1 Limits for conducted emissions

Frequency, MHz	Class B limit, dB(μV)		Class A limit, dB(μV)	
	QP	AVRG	QP	AVRG
0.15 - 0.5	66 - 56*	56 - 46*	79	66
0.5 - 5.0	56	46	73	60
5.0 - 30	60	50	73	60

* The limit decreases linearly with the logarithm of frequency.

7.4.2 Test procedure

7.4.2.1 The EUT was set up as shown in Figure 7.4.1, energized and the EUT performance was checked.

7.4.2.2 The measurements were performed at the EUT mains terminals with the LISN, connected to the EMI receiver in the frequency range referred to in Table 7.4.2. The unused coaxial connector of the LISN was terminated with 50 Ohm.

7.4.2.3 The position of the EUT cables was varied to find the highest emission.

7.4.2.4 The worst test results with respect to the limits were recorded in Table 7.4.2 and shown in the associated plots.

Figure 7.4.1 Setup for conducted emission measurements, table-top EUT

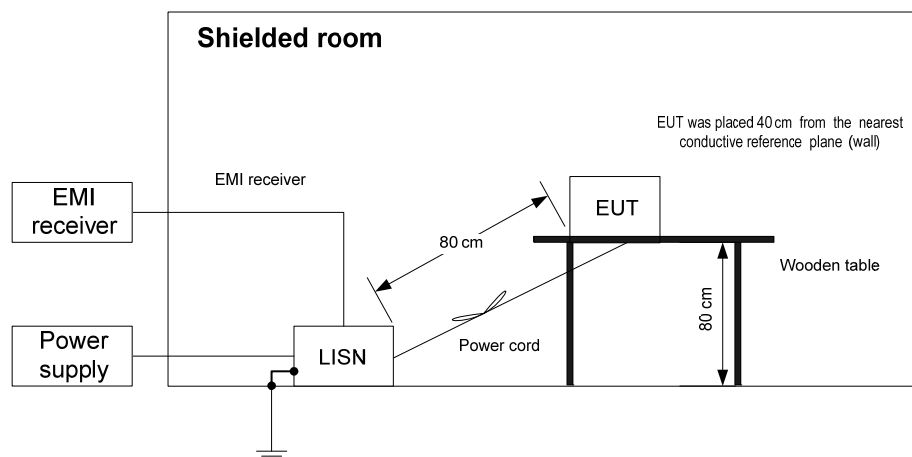



Test specification:	FCC Part 15, Section 207 / RSS-Gen, Section 7.2.2, Conducted emission		
Test procedure:	ANSI C63.4, Section 13.1.3		
Test mode:	Compliance	Verdict: PASS	
Date(s):	28-Jul-15		
Temperature: 24 °C	Air Pressure: 1004 hPa	Relative Humidity: 45 %	Power Supply: 120 VAC
Remarks:			

Table 7.4.2 Conducted emission test results

LINE: AC mains
EUT SET UP: TABLE-TOP
TEST SITE: SHIELDED ROOM
DETECTORS USED: PEAK / QUASI-PEAK / AVERAGE
FREQUENCY RANGE: 150 kHz - 30 MHz
RESOLUTION BANDWIDTH: 9 kHz

Frequency, MHz	Peak emission, dB(µV)	Quasi-peak			Average			Line ID	Verdict
		Measured emission, dB(µV)	Limit, dB(µV)	Margin, dB*	Measured emission, dB(µV)	Limit, dB(µV)	Margin, dB*		
0.382500	47.68	45.21	58.25	-13.04	33.95	48.25	-14.30	L1	Pass
1.941567	52.44	44.90	56.00	-11.10	24.67	46.00	-21.33		
2.276652	50.54	45.10	56.00	-10.90	22.96	46.00	-23.04		
3.553838	55.68	47.66	56.00	-8.34	29.37	46.00	-16.63		
0.150000	51.30	49.62	66.00	-16.38	34.27	56.00	-21.73	L2	Pass
1.193586	45.16	34.78	56.00	-21.22	22.49	46.00	-23.51		
1.915010	50.16	41.25	56.00	-14.75	25.86	46.00	-20.14		

*- Margin = Measured emission - specification limit.

Reference numbers of test equipment used

HL 0447	HL 0787	HL 1425	HL 1513	HL 3612			
---------	---------	---------	---------	---------	--	--	--

Full description is given in Appendix A.



HERMON LABORATORIES

Test specification:		FCC Part 15, Section 207 / RSS-Gen, Section 7.2.2, Conducted emission	
Test procedure:		ANSI C63.4, Section 13.1.3	
Test mode:		Compliance	
Date(s):		28-Jul-15	
Temperature: 24 °C		Air Pressure: 1004 hPa	
		Relative Humidity: 45 %	
		Power Supply: 120 VAC	
Remarks:			
		Verdict: PASS	

Plot 7.4.1 Conducted emission measurements

LINE: L1
LIMIT: QUASI-PEAK, AVERAGE
DETECTOR: PEAK



ACTV DET: PEAK
MEAS DET: PEAK OP AVG
MKR 1.94 MHz
48.33 dBµV

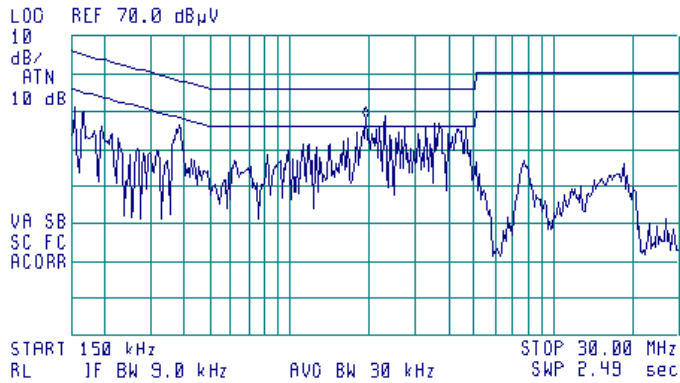

Plot 7.4.2 Conducted emission measurements

LINE: L2
LIMIT: QUASI-PEAK, AVERAGE
DETECTOR: PEAK



ACTV DET: PEAK
MEAS DET: PEAK OP AVG
MKR 1.92 MHz
46.89 dBµV

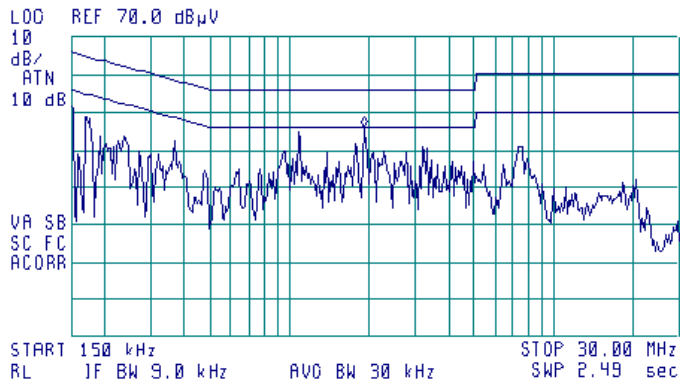



Test specification:	FCC Part 15, Section 203 / RSS-Gen, Section 7.1.4, Antenna requirements		
Test procedure:	Visual inspection / supplier declaration		
Test mode:	Compliance	Verdict:	PASS
Date(s):	29-Jul-15		
Temperature: 24 °C	Air Pressure: 1005 hPa	Relative Humidity: 45 %	Power Supply: 120 VAC
Remarks:			

7.5 Antenna requirements

The EUT was verified for compliance with antenna requirements. A transmitter shall be designed to ensure that no antenna other than that furnished by the responsible party will be used with the device. It may be either permanently attached or employs a unique antenna connector for every antenna proposed for use with the EUT. This requirement does not apply to professionally installed transmitters. The rationale for compliance with the above requirements was either visual inspection results or supplier declaration. The summary of results is provided in Table 7.5.1.

Table 7.5.1 Antenna requirements

Requirement	Rationale	Verdict
The transmitter antenna is permanently attached	Visual inspection	Comply
The transmitter employs a unique antenna connector	NA	
The transmitter requires professional installation	NA	

Photograph 7.5.1 Antenna assembly





Test specification:	FCC Part 15, Section 107/ICES-003, Section 6.1, Class B, Conducted emission at AC power port		
Test procedure:	ANSI C63.4, Section 13.1.3		
Test mode:	Compliance	Verdict:	PASS
Date(s):	28-Jul-15		
Temperature: 24 °C	Air Pressure: 1004 hPa	Relative Humidity: 45 %	Power Supply: 120 VAC
Remarks:			

8 Unintentional emissions

8.1 Conducted emissions

8.1.1 General

This test was performed to measure common mode conducted emissions at the EUT power port. The specification test limits are given in Table 8.1.1.

Table 8.1.1 Limits for conducted emissions

Frequency, MHz	Class B limit, dB(μV)		Class A limit, dB(μV)	
	QP	AVRG	QP	AVRG
0.15 - 0.5	66 - 56*	56 - 46*	79	66
0.5 - 5.0	56	46	73	60
5.0 - 30	60	50	73	60

* The limit decreases linearly with the logarithm of frequency.

8.1.2 Test procedure

8.1.2.1 The EUT was set up as shown in Figure 8.1.1 and the associated photographs, energized and the EUT performance was checked.

8.1.2.2 The measurements were performed at the EUT mains terminals with the LISN, connected to the EMI receiver in the frequency range referred to in Table 8.1.2. The unused coaxial connector of the LISN was terminated with 50 Ohm.

8.1.2.3 The position of the EUT cables was varied to find the highest emission.

8.1.2.4 The worst test results with respect to the limits were recorded in Table 8.1.2 and shown in the associated plots.



Test specification:	FCC Part 15, Section 107/ICES-003, Section 6.1, Class B, Conducted emission at AC power port		
Test procedure:	ANSI C63.4, Section 13.1.3		
Test mode:	Compliance	Verdict:	PASS
Date(s):	28-Jul-15		
Temperature: 24 °C	Air Pressure: 1004 hPa	Relative Humidity: 45 %	Power Supply: 120 VAC
Remarks:			

Figure 8.1.1 Setup for conducted emission measurements, table-top EUT

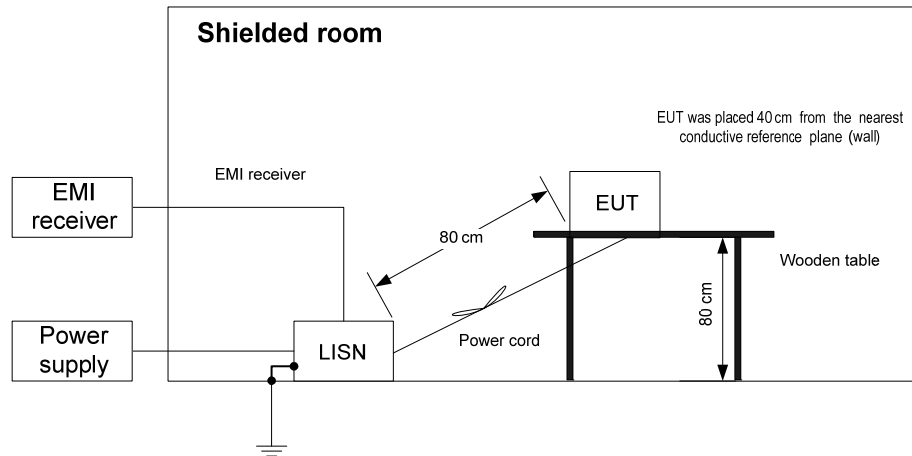

Photograph 8.1.1 Setup for conducted emissions measurements





Test specification:	FCC Part 15, Section 107/ICES-003, Section 6.1, Class B, Conducted emission at AC power port		
Test procedure:	ANSI C63.4, Section 13.1.3		
Test mode:	Compliance	Verdict: PASS	
Date(s):	28-Jul-15		
Temperature: 24 °C	Air Pressure: 1004 hPa	Relative Humidity: 45 %	Power Supply: 120 VAC
Remarks:			

Table 8.1.2 Conducted emission test results

LINE: AC mains
 EUT SET UP: TABLE-TOP
 TEST SITE: SHIELDED ROOM
 DETECTORS USED: PEAK / QUASI-PEAK / AVERAGE
 FREQUENCY RANGE: 150 kHz - 30 MHz
 RESOLUTION BANDWIDTH: 9 kHz

Frequency, MHz	Peak emission, dB(µV)	Quasi-peak			Average			Line ID	Verdict
		Measured emission, dB(µV)	Limit, dB(µV)	Margin, dB*	Measured emission, dB(µV)	Limit, dB(µV)	Margin, dB*		
0.382500	47.68	45.21	58.25	-13.04	33.95	48.25	-14.30	L1	Pass
1.941567	52.44	44.90	56.00	-11.10	24.67	46.00	-21.33		
2.276652	50.54	45.10	56.00	-10.90	22.96	46.00	-23.04		
3.553838	55.68	47.66	56.00	-8.34	29.37	46.00	-16.63		
0.150000	51.30	49.62	66.00	-16.38	34.27	56.00	-21.73	L2	Pass
1.193586	45.16	34.78	56.00	-21.22	22.49	46.00	-23.51		
1.915010	50.16	41.25	56.00	-14.75	25.86	46.00	-20.14		

*- Margin = Measured emission - specification limit.

Reference numbers of test equipment used

HL 0447	HL 0787	HL 1425	HL 1513	HL 3612			
---------	---------	---------	---------	---------	--	--	--

Full description is given in Appendix A.



HERMON LABORATORIES

Test specification:	FCC Part 15, Section 107/ICES-003, Section 6.1, Class B, Conducted emission at AC power port		
Test procedure:	ANSI C63.4, Section 13.1.3		
Test mode:	Compliance	Verdict:	PASS
Date(s):	28-Jul-15		
Temperature: 24 °C	Air Pressure: 1004 hPa	Relative Humidity: 45 %	Power Supply: 120 VAC
Remarks:			

Plot 8.1.1 Conducted emission measurements

LINE: L1
LIMIT: QUASI-PEAK, AVERAGE
DETECTOR: PEAK



ACTV DET: PEAK
MEAS DET: PEAK OP AVG
MKR 1.94 MHz
48.33 dBµV

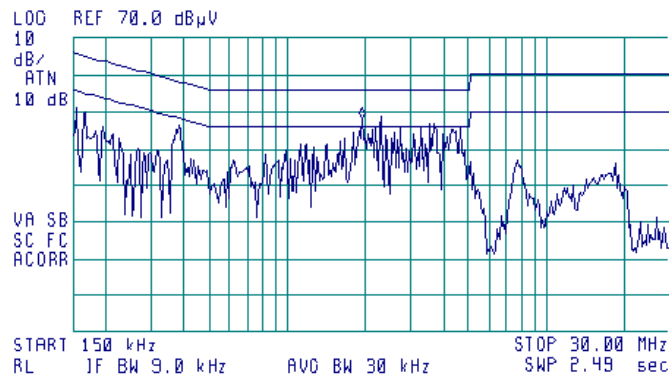

Plot 8.1.2 Conducted emission measurements

LINE: L2
LIMIT: QUASI-PEAK, AVERAGE
DETECTOR: PEAK



ACTV DET: PEAK
MEAS DET: PEAK OP AVG
MKR 1.92 MHz
46.09 dBµV

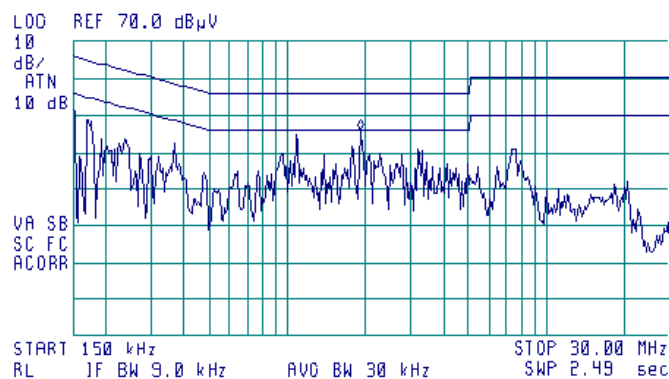



Test specification:	FCC Part 15, Section 109 / RSS-Gen, Section 7.1.2 / ICES-003, Section 6.2, Class B, Radiated emission		
Test procedure:	ANSI C63.4, Sections 11.6 and 12.1.4 / RSS-Gen, Section 4.10 / CISPR 22		
Test mode:	Compliance	Verdict:	PASS
Date(s):	27-Jul-15		
Temperature: 24 °C	Air Pressure: 1006 hPa	Relative Humidity: 50 %	Power Supply: 120 VAC
Remarks:			

8.2 Radiated emission measurements

8.2.1 General

This test was performed to measure radiated emissions from the EUT enclosure. Specification test limits are given in Table 8.2.1, in Table 8.2.2.

Table 8.2.1 Radiated emission limits according to FCC Part 15, Section 109 and ICES-003, Section 6.2

Frequency, MHz	Class B limit, dB(µV/m)		Class A limit, dB(µV/m)	
	10 m distance	3 m distance	10 m distance	3 m distance
30 - 88	29.5*	40.0	39.0	49.5*
88 - 216	33.0*	43.5	43.5	54.0*
216 - 960	35.5*	46.0	46.4	56.9*
960 - 5 th harmonic**	43.5*	54.0	49.5	60.0*

* - The limit for test distance other than specified was calculated using the inverse linear distance extrapolation factor as follows: $Lim_{S_2} = Lim_{S_1} + 20 \log(S_1/S_2)$, where S_1 and S_2 – standard defined and test distance respectively in meters.

Table 8.2.2 Radiated emission limits according to RSS-Gen, Section 7.1.2

Frequency, MHz	Field strength limit at 3 m test distance, dB(µV/m)
30 - 88	40.0
88 - 216	43.5
216 - 960	46.0
960 - 3 rd harmonic**	54.0

** - harmonic of the highest frequency the EUT generates, uses, operates or tunes to.

8.2.2 Test procedure

8.2.2.1 The EUT was set up as shown in Figure 8.2.1 and associated photographs, energized and the performance check was conducted.

8.2.2.2 The specified frequency range was investigated with biconilog antenna connected to EMI receiver. To find maximum radiation the turntable was rotated 360°, the measuring antenna height was changed from 1 to 4 m, its polarization was switched from vertical to horizontal and the EUT cables position was varied.

8.2.2.3 The worst test results (the lowest margins) were provided in the associated tables and plots.



Test specification:	FCC Part 15, Section 109 / RSS-Gen, Section 7.1.2 / ICES-003, Section 6.2, Class B, Radiated emission		
Test procedure:	ANSI C63.4, Sections 11.6 and 12.1.4 / RSS-Gen, Section 4.10 / CISPR 22		
Test mode:	Compliance	Verdict:	PASS
Date(s):	27-Jul-15		
Temperature: 24 °C	Air Pressure: 1006 hPa	Relative Humidity: 50 %	Power Supply: 120 VAC
Remarks:			

Figure 8.2.1 Setup for radiated emission measurements in anechoic chamber, table-top equipment

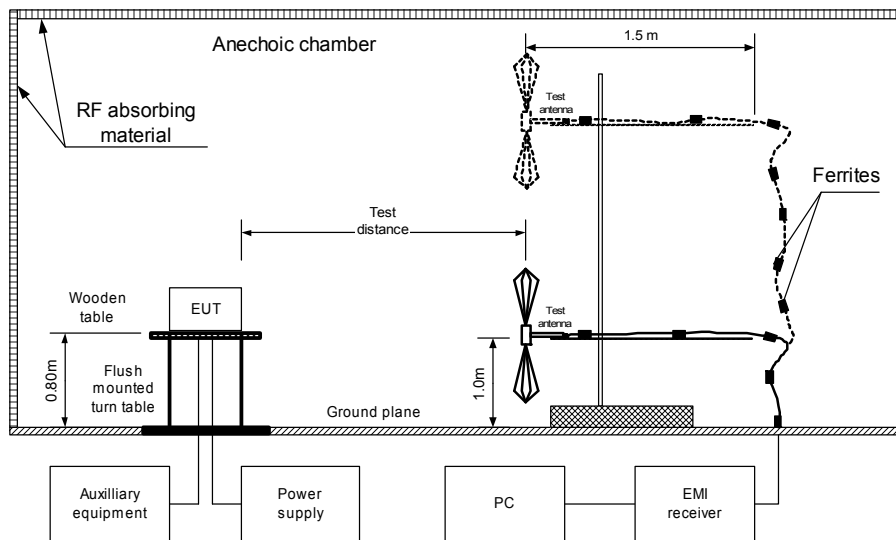

Photograph 8.2.1 Setup for radiated emission measurements





Test specification:	FCC Part 15, Section 109 / RSS-Gen, Section 7.1.2 / ICES-003, Section 6.2, Class B, Radiated emission		
Test procedure:	ANSI C63.4, Sections 11.6 and 12.1.4 / RSS-Gen, Section 4.10 / CISPR 22		
Test mode:	Compliance	Verdict:	PASS
Date(s):	27-Jul-15		
Temperature: 24 °C	Air Pressure: 1006 hPa	Relative Humidity: 50 %	Power Supply: 120 VAC
Remarks:			

Photograph 8.2.2 Setup for radiated emission measurements



Photograph 8.2.3 Setup for radiated emission measurements, EUT cabling





Test specification:	FCC Part 15, Section 109 / RSS-Gen, Section 7.1.2 / ICES-003, Section 6.2, Class B, Radiated emission		
Test procedure:	ANSI C63.4, Sections 11.6 and 12.1.4 / RSS-Gen, Section 4.10 / CISPR 22		
Test mode:	Compliance	Verdict: PASS	
Date(s):	27-Jul-15		
Temperature: 24 °C	Air Pressure: 1006 hPa	Relative Humidity: 50 %	Power Supply: 120 VAC
Remarks:			

Table 8.2.3 Radiated emission test results

EUT SET UP: TABLE-TOP
LIMIT: Class B
EUT OPERATING MODE: Stand-by and Receive
TEST SITE: SEMI ANECHOIC CHAMBER
TEST DISTANCE: 3 m

FREQUENCY RANGE: 30 MHz – 1000 MHz
RESOLUTION BANDWIDTH: 120 kHz

Frequency, MHz	Peak emission, dB(µV/m)	Quasi-peak			Antenna polarization	Antenna height, m	Turn-table position**, degrees	Verdict
		Measured emission, dB(µV/m)	Limit, dB(µV/m)	Margin, dB*				
100.003750	23.13	21.25	43.50	-22.25	Vertical	1.0	230	Pass
125.008750	29.11	27.21	43.50	-16.29	Vertical	1.0	320	
150.007250	33.64	33.02	43.50	-10.48	Vertical	1.0	260	
175.010250	28.25	26.45	43.50	-17.05	Vertical	1.0	180	
200.009250	26.72	25.43	43.50	-18.07	Vertical	1.0	190	
383.982500	28.26	25.66	46.00	-20.34	Horizontal	1.0	0	

DETECTORS USED: PEAK / AVERAGE
FREQUENCY RANGE: 1000 MHz – 5000 MHz
RESOLUTION BANDWIDTH: 1000 kHz

Frequency, MHz	Peak			Average			Antenna polarization	Antenna height, m	Turn-table position**, degrees	Verdict
	Measured emission, dB(µV/m)	Limit, dB(µV/m)	Margin, dB*	Measured emission, dB(µV/m)	Limit, dB(µV/m)	Margin, dB*				
No signals were found										

*- Margin = Measured emission - specification limit.
**- EUT front panel refer to 0 degrees position of turntable.

Reference numbers of test equipment used

HL 0521	HL 0604	HL 2432	HL 2780	HL 4353	HL 4722	HL 4932	
---------	---------	---------	---------	---------	---------	---------	--

Full description is given in Appendix A.



Test specification:	FCC Part 15, Section 109 / RSS-Gen, Section 7.1.2 / ICES-003, Section 6.2, Class B, Radiated emission		
Test procedure:	ANSI C63.4, Sections 11.6 and 12.1.4 / RSS-Gen, Section 4.10 / CISPR 22		
Test mode:	Compliance	Verdict:	PASS
Date(s):	27-Jul-15		
Temperature: 24 °C	Air Pressure: 1006 hPa	Relative Humidity: 50 %	Power Supply: 120 VAC
Remarks:			

Plot 8.2.1 Radiated emission measurements in 30 - 1000 MHz range, vertical antenna polarization

TEST SITE: Semi anechoic chamber
LIMIT: Class B
TEST DISTANCE: 3 m
EUT OPERATING MODE: Receive / Stand-by

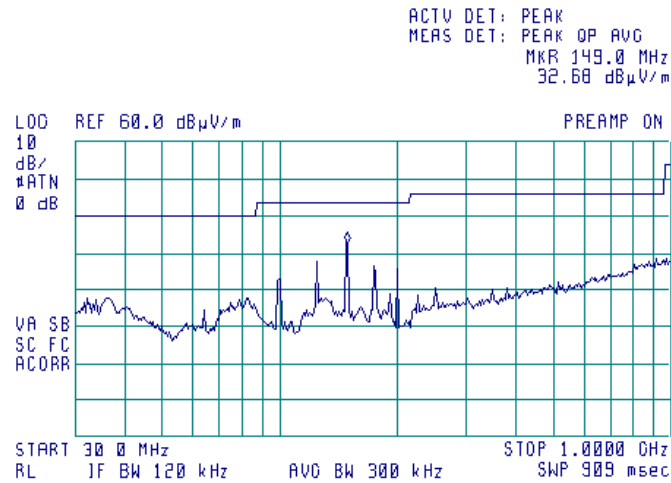

Plot 8.2.2 Radiated emission measurements in 30 - 1000 MHz range, horizontal antenna polarization

TEST SITE: Semi anechoic chamber
LIMIT: Class B
TEST DISTANCE: 3 m
EUT OPERATING MODE: Receive / Stand-by

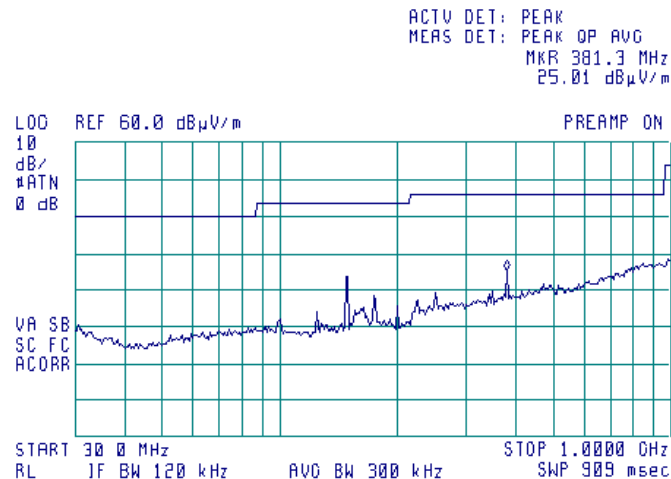



Test specification:	FCC Part 15, Section 109 / RSS-Gen, Section 7.1.2 / ICES-003, Section 6.2, Class B, Radiated emission		
Test procedure:	ANSI C63.4, Sections 11.6 and 12.1.4 / RSS-Gen, Section 4.10 / CISPR 22		
Test mode:	Compliance	Verdict: PASS	
Date(s):	27-Jul-15		
Temperature: 24 °C	Air Pressure: 1006 hPa	Relative Humidity: 50 %	Power Supply: 120 VAC
Remarks:			

Plot 8.2.3 Radiated emission measurements in 1-5 GHz range, vertical & horizontal antenna polarization

TEST SITE: Semi anechoic chamber
LIMIT: Class B
TEST DISTANCE: 3 m
EUT OPERATING MODE: Receive / Stand-by

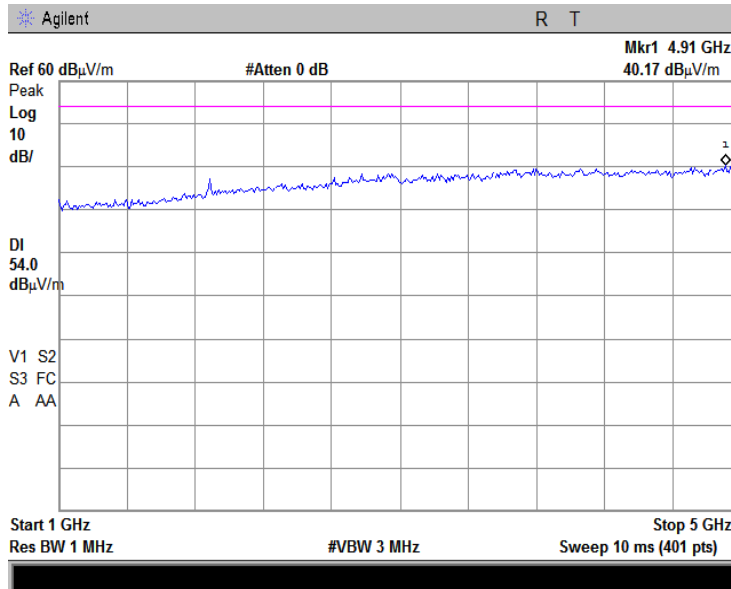

**9 APPENDIX A Test equipment and ancillaries used for tests**

HL No	Description	Manufacturer	Model	Ser. No.	Last Cal./ Check	Due Cal./ Check
0446	Antenna, Loop, Active, 10 kHz - 30 MHz	EMCO	6502	2857	13-Jan-15	13-Jan-16
0447	LISN, 16/2, 300V RMS, 50 Ohm/50 uH + 5 Ohm, STD CISPR 16-1	Hermon Laboratories	LISN 16 - 1	066	23-Oct-14	23-Oct-15
0521	EMI Receiver (Spectrum Analyzer) with RF filter section 9 kHz-6.5 GHz	Hewlett Packard	8546A	3617A 00319, 3448A002 53	22-Oct-14	22-Oct-15
0604	Antenna BiconiLog Log-Periodic/T Bow-TIE, 26 - 2000 MHz	EMCO	3141	9611-1011	15-May-15	15-May-16
0787	Transient Limiter 9 kHz-200 MHz	Hewlett Packard	11947A	3107A018 77	13-Oct-14	13-Oct-15
1425	EMI Receiver, 9 kHz - 2.9 GHz, System: HL1426, HL1427	Agilent Technologies	8542E	3710A002 22, 3705A002 04	24-Dec-14	24-Dec-15
1513	Cable RF, 8 m, BNC/BNC	Belden	M17/167 MIL-C-17	1513	09-Sep-14	09-Sep-15
2432	Antenna, Double-Ridged Waveguide Horn 1-18 GHz	EMC Test Systems	3115	00027177	17-Apr-15	17-Apr-16
2780	EMC analyzer, 100 Hz to 26.5 GHz	Agilent Technologies	E7405A	MY451024 62	02-Sep-14	02-Sep-15
3612	Cable RF, 17.5 m, N type-N type	Teldor	RG-214/U	NA	07-Dec-14	07-Dec-15
3818	PSA Series Spectrum Analyzer, 3 Hz- 44 GHz	Agilent Technologies	E4446A	MY482502 88	29-Apr-15	29-Apr-16
4353	Low Loss Armored Test Cable, DC - 18 GHz, 6.2 m, N type-M/N type-M	MegaPhase	NC29- N1N1-244	12025101 003	15-Mar-15	15-Mar-16
4722	Low Loss Armored Test Cable, DC - 18 GHz, 6.2 m, N type-M/N type-M	MegaPhase	NC29- N1N1-244	51228701 001	26-Aug-14	26-Aug-15
4932	Microwave preamplifier, 500 MHz to 18 GHz, 40 dB Gain	Com-Power Corporation	PAM- 118A	551029	18-Nov-14	18-Nov-15

10 APPENDIX B Measurement uncertainties

Expanded uncertainty at 95% confidence in Hermon Labs EMC measurements

Test description	Expanded uncertainty
Conducted emissions with LISN	9 kHz to 150 kHz: ± 3.9 dB 150 kHz to 30 MHz: ± 3.8 dB
Radiated emissions at 10 m measuring distance Horizontal polarization Vertical polarization	Biconilog antenna: ± 5.0 dB Biconical antenna: ± 5.0 dB Log periodic antenna: ± 5.1 dB Double ridged horn antenna: ± 5.3 dB Biconilog antenna: ± 5.5 dB Biconical antenna: ± 5.5 dB Log periodic antenna: ± 5.6 dB Double ridged horn antenna: ± 5.8 dB
Radiated emissions at 3 m measuring distance Horizontal polarization Vertical polarization	Biconilog antenna: ± 5.3 dB Biconical antenna: ± 5.0 dB Log periodic antenna: ± 5.3 dB Double ridged horn antenna: ± 5.3 dB Biconilog antenna: ± 6.0 dB Biconical antenna: ± 5.7 dB Log periodic antenna: ± 6.0 dB Double ridged horn antenna: ± 6.0 dB
Conducted emissions at RF antenna connector	9 kHz to 2.9 GHz: ± 2.6 dB 2.9 GHz to 6.46 GHz: ± 3.5 dB 6.46 GHz to 13.2 GHz: ± 4.3 dB 13.2 GHz to 22.0 GHz: ± 5.0 dB 22.0 GHz to 26.8 GHz: ± 5.5 dB 26.8 GHz to 40.0 GHz: ± 4.8 dB
Duty cycle, timing (Tx ON / OFF) and average factor measurements	± 1.0 %
Occupied bandwidth	± 8.0 %

Hermon Laboratories is accredited by A2LA for calibration according to present requirements of ISO/IEC 17025 and NCSL Z540-1. The accreditation is granted to perform calibration of parameters that are listed in the Scope of Hermon Laboratories Accreditation.

Hermon Laboratories calibrates its reference and transfer standards by calibration laboratories accredited to ISO/IEC 17025 by a mutually recognized Accreditation Body or by a recognized national metrology institute. All reference and transfer standards used in the calibration system are traceable to national or international standards.

In-house calibration of all test and measurement equipment is performed on a regular basis according to Hermon Laboratories calibration procedures, manufacturer calibration/verification procedures or procedures defined in the relevant standards. The Hermon Laboratories test and measurement equipment is calibrated within the tolerances specified by the manufacturers and/or by the relevant standards.

11 APPENDIX C Test laboratory description

Tests were performed at Hermon Laboratories Ltd., which is a fully independent, private, EMC, safety, environmental and telecommunication testing facility.

Hermon Laboratories is listed by the Federal Communications Commission (USA) for all parts of Code of Federal Regulations 47 (CFR 47), Registration Numbers 90624 for OATS and 90623 for the anechoic chamber; by Industry Canada for electromagnetic emissions (file numbers IC 2186A-1 for OATS), certified by VCCI, Japan (the registration numbers are R-808 for OATS, R-1082 for anechoic chamber, G-27 for full-anechoic chamber for RE measurements above 1 GHz, C-845 for conducted emissions site, T-1606 for conducted emissions at telecommunication ports), has a status of a Telefication - Listed Testing Laboratory, Certificate No. L138/00. The laboratory is accredited by American Association for Laboratory Accreditation (USA) according to ISO/IEC 17025 for electromagnetic compatibility, product safety, telecommunications testing and environmental simulation (for exact scope please refer to Certificate No. 839.01). The FCC Designation Number is US1003.

Address: P.O. Box 23, Binyamina 30500, Israel.
Telephone: +972 4628 8001
Fax: +972 4628 8277
e-mail: mail@hermonlabs.com
website: www.hermonlabs.com

Person for contact: Mr. Alex Usoskin, CEO.

12 APPENDIX D Specification references

47CFR part 15: 2014	Radio Frequency Devices.
ANSI C63.2: 1996	American National Standard for Instrumentation-Electromagnetic Noise and Field Strength, 10 kHz to 40 GHz-Specifications.
ANSI C63.4: 2009	American National Standard for Methods of Measurement of Radio-Noise Emissions from Low-Voltage Electrical and Electronic Equipment in the Range of 9 kHz to 40 GHz.
RSS-210 Issue 8: 2010	Low Power Licence- Exempt Radiocommunication Devices
RSS-Gen Issue 4: 2014	General Requirements and Information for the Certification of Radiocommunication Equipment
ICES-003 issue 5:2012	Information Technology Equipment (ITE) – Limits and methods of measurement



13 APPENDIX E Test equipment correction factors

Correction factor
Line impedance stabilization network
Model LISN 16 - 1
Hermon Laboratories, HL 0447

Frequency, kHz	Correction factor, dB
10	4.9
15	2.86
20	1.83
25	1.25
30	0.91
35	0.69
40	0.53
50	0.35
60	0.25
70	0.18
80	0.14
90	0.11
100	0.09
125	0.06
150	0.04

The correction factor in dB is to be added to meter readings of an interference analyzer or a spectrum analyzer.



Antenna factor
Active loop antenna
Model 6502, S/N 2857, HL 0446

Frequency, MHz	Magnetic antenna factor, dB	Electric antenna factor, dB
0.009	-32.8	18.7
0.010	-33.8	17.7
0.020	-38.3	13.2
0.050	-41.1	10.4
0.075	-41.3	10.2
0.100	-41.6	9.9
0.150	-41.7	9.8
0.250	-41.6	9.9
0.500	-41.8	9.8
0.750	-41.9	9.7
1.000	-41.4	10.1
2.000	-41.5	10.0
3.000	-41.4	10.2
4.000	-41.4	10.1
5.000	-41.5	10.1
10.000	-41.9	9.6
15.000	-41.9	9.6
20.000	-42.2	9.3
25.000	-42.8	8.7
30.000	-44.0	7.5

Antenna factor in dB(1/m) is to be added to receiver meter reading in dB(μ V) to convert it into field strength in dB(μ V/m).



Antenna factor
Biconilog antenna EMCO Model 3141
Ser.No.1011, HL 0604

Frequency, MHz	Antenna factor, dB(1/m)	Frequency, MHz	Antenna factor, dB(1/m)	Frequency, MHz	Antenna factor, dB(1/m)
26	7.8	580	20.6	1320	27.8
28	7.8	600	21.3	1340	28.3
30	7.8	620	21.5	1360	28.2
40	7.2	640	21.2	1380	27.9
60	7.1	660	21.4	1400	27.9
70	8.5	680	21.9	1420	27.9
80	9.4	700	22.2	1440	27.8
90	9.8	720	22.2	1460	27.8
100	9.7	740	22.1	1480	28.0
110	9.3	760	22.3	1500	28.5
120	8.8	780	22.6	1520	28.9
130	8.7	800	22.7	1540	29.6
140	9.2	820	22.9	1560	29.8
150	9.8	840	23.1	1580	29.6
160	10.2	860	23.4	1600	29.5
170	10.4	880	23.8	1620	29.3
180	10.4	900	24.1	1640	29.2
190	10.3	920	24.1	1660	29.4
200	10.6	940	24.0	1680	29.6
220	11.6	960	24.1	1700	29.8
240	12.4	980	24.5	1720	30.3
260	12.8	1000	24.9	1740	30.8
280	13.7	1020	25.0	1760	31.1
300	14.7	1040	25.2	1780	31.0
320	15.2	1060	25.4	1800	30.9
340	15.4	1080	25.6	1820	30.7
360	16.1	1100	25.7	1840	30.6
380	16.4	1120	26.0	1860	30.6
400	16.6	1140	26.4	1880	30.6
420	16.7	1160	27.0	1900	30.6
440	17.0	1180	27.0	1920	30.7
460	17.7	1200	26.7	1940	30.9
480	18.1	1220	26.5	1960	31.2
500	18.5	1240	26.5	1980	31.6
520	19.1	1260	26.5	2000	32.0
540	19.5	1280	26.6		
560	19.8	1300	27.0		

Antenna factor in dB(1/m) is to be added to receiver meter reading in dB(μV) to convert it into field strength in dB(μV/m).



Antenna factor
Double-ridged guide horn antenna
Model 3115, serial number: 00027177, HL 2432

Frequency, MHz	Antenna factor. dB(1/m)
1000.0	24.7
1500.0	25.7
2000.0	27.8
2500.0	28.9
3000.0	30.7
3500.0	31.8
4000.0	33.0
4500.0	32.8
5000.0	34.2
5500.0	34.9
6000.0	35.2
6500.0	35.4
7000.0	36.3
7500.0	37.3
8000.0	37.5
8500.0	38.0
9000.0	38.3
9500.0	38.3
10000.0	38.7
10500.0	38.7
11000.0	38.9
11500.0	39.5
12000.0	39.5
12500.0	39.4
13000.0	40.5
13500.0	40.8
14000.0	41.5
14500.0	41.3
15000.0	40.2
15500.0	38.7
16000.0	38.5
16500.0	39.8
17000.0	41.9
17500.0	45.8
18000.0	49.1

Antenna factor in dB(1/m) is to be added to receiver meter reading in dB(μ V) to convert it into field strength in dB(μ V/m).



Cable loss
Cable coaxial, RG-214/U, N type-N type, 17 m
Teldor, HL 3612

Frequency, MHz	Cable loss, dB
0.1	0.05
0.5	0.07
1	0.10
3	0.22
5	0.29
10	0.39
30	0.68
50	0.90
100	1.27
150	1.58
200	1.80
250	2.12
300	2.36
350	2.60
400	2.82
450	2.99
500	3.23
550	3.40
600	3.56
650	3.71
700	3.90
750	4.04
800	4.23
850	4.39
900	4.55
950	4.65
1000	4.79



Cable loss
Low Loss Armored Test Cable, MegaPhase, 18 GHz, 6.2 m, N type-M/N type-M,
NC29-N1N1-244S/N 12025101 003,
HL 4353

Frequency, MHz	Cable loss, dB	Frequency, MHz	Cable loss, dB
50	0.20	9000	2.71
100	0.27	9500	2.81
300	0.47	10000	2.90
500	0.61	10500	2.97
1000	0.87	11000	3.06
1500	1.07	11500	3.13
2000	1.24	12000	3.20
2500	1.39	12500	3.26
3000	1.53	13000	3.34
3500	1.65	13500	3.39
4000	1.77	14000	3.47
4500	1.89	14500	3.54
5000	1.99	15000	3.62
5500	2.07	15500	3.69
6000	2.20	16000	3.76
6500	2.30	16500	3.83
7000	2.39	17000	3.86
7500	2.51	17500	3.94
8000	2.58	18000	4.02
8500	2.65		



Cable loss
Low Loss Armored Test Cable, MegaPhase, 18 GHz, 6.2 m, N type-M/N type-M,
NC29-N1N1-244, S/N 51228701001
HL 4722

Frequency, MHz	Cable loss, dB	Frequency, MHz	Cable loss, dB
50	0.22	9000	2.93
100	0.30	9500	3.06
300	0.52	10000	3.16
500	0.66	10500	3.20
1000	0.93	11000	3.34
1500	1.15	11500	3.39
2000	1.33	12000	3.48
2500	1.49	12500	3.55
3000	1.64	13000	3.66
3500	1.77	13500	3.75
4000	1.90	14000	3.76
4500	2.03	14500	3.87
5000	2.17	15000	3.98
5500	2.30	15500	4.01
6000	2.39	16000	4.14
6500	2.51	16500	4.15
7000	2.59	17000	4.32
7500	2.67	17500	4.36
8000	2.76	18000	4.38
8500	2.84		



14 APPENDIX F Abbreviations and acronyms

A	ampere
AC	alternating current
A/m	ampere per meter
AM	amplitude modulation
AVRG	average (detector)
cm	centimeter
dB	decibel
dBm	decibel referred to one milliwatt
dB(μ V)	decibel referred to one microvolt
dB(μ V/m)	decibel referred to one microvolt per meter
dB(μ A)	decibel referred to one microampere
DC	direct current
EIRP	equivalent isotropically radiated power
ERP	effective radiated power
EUT	equipment under test
F	frequency
GHz	gigahertz
GND	ground
H	height
HL	Hermon laboratories
Hz	hertz
k	kilo
kHz	kilohertz
LO	local oscillator
m	meter
MHz	megahertz
min	minute
mm	millimeter
ms	millisecond
μ s	microsecond
NA	not applicable
NB	narrow band
OATS	open area test site
Ω	Ohm
PM	pulse modulation
PS	power supply
ppm	part per million (10^{-6})
QP	quasi-peak
RE	radiated emission
RF	radio frequency
rms	root mean square
Rx	receive
s	second
T	temperature
Tx	transmit
V	volt
WB	wideband

END OF DOCUMENT