



Hermon Laboratories Ltd.
Harakevet Industrial Zone, Binyamina 30500,
Israel
Tel. +972-4-6288001
Fax. +972-4-6288277
E-mail: mail@hermonlabs.com

TEST REPORT

ACCORDING TO: FCC CFR 47 Part 15 subpart C, section 15.231,
RSS-210 issue 8 Annex 1

FOR:

**Essence Smartcare Ltd.
Voice Panic Device
Model:ES700VPD
FCC ID:YXG-ES700VPD
IC:11061A-ES700VPD**

This report is in conformity with ISO/ IEC 17025. The "A2LA Accredited" symbol endorsement applies only to the tests and calibrations that are listed in the scope of Hermon Laboratories accreditation. The test results relate only to the items tested. This test report shall not be reproduced in any form except in full with the written approval of Hermon Laboratories Ltd.

Table of contents

1	Applicant information	3
2	Equipment under test attributes	3
3	Manufacturer information	3
4	Test details	3
5	Tests summary	4
6	EUT description	5
6.1	General information	5
6.2	Test configuration	5
6.3	Changes made in EUT	5
6.4	Transmitter characteristics	6
7	Transmitter tests according to 47CFR part 15 subpart C requirements	7
7.1	Periodic operation requirements	7
7.2	Field strength of emissions	11
7.3	Occupied bandwidth test	27
7.4	Conducted emissions	30
7.5	Antenna requirements	33
8	APPENDIX A Test equipment and ancillaries used for tests	34
9	APPENDIX B Measurement uncertainties	36
10	APPENDIX C Test laboratory description	37
11	APPENDIX D Specification references	37
12	APPENDIX E Test equipment correction factors	38
13	APPENDIX F Abbreviations and acronyms	50

1 Applicant information

Client name: Essence Smartcare Ltd.
Address: 12 Abba Eban avenue, Ackerstein Tower Bldg. D, P.O.Box 2073, Herzliya 4612001, Israel
Telephone: +972 732 447 735
Fax: +972 9772 9962
E-mail: israelgo@essence-grp.com
Contact name: Mr. Israel Gottesman

2 Equipment under test attributes

Product name: Voice Panic Device
Product type: Transceiver
Model(s): ES700VPD
Serial number: 1
Hardware version: 3_PCB
Software release: 1.14
Receipt date 18-Aug-16

3 Manufacturer information

Manufacturer name: Essence Smartcare Ltd.
Address: 12 Abba Eban avenue, Ackerstein Tower Bldg. D, P.O.Box 2073, Herzliya 4612001, Israel
Telephone: +972 732 447 735
Fax: +972 9772 9962
E-Mail: israelgo@essence-grp.com
Contact name: Mr. Israel Gottesman

4 Test details

Project ID: 28514
Location: Primary: Hermon Laboratories Ltd. Harakevet Industrial Zone, Binyamina 30500, Israel
Satellite: Hermon Laboratories Ltd. Hefetz-Haim 10, Tel Aviv 6744124, Israel
Test started: 18-Aug-16
Test completed: 29-Aug-16
Test specification(s): FCC 47CFR part 15, subpart C, §15.231 and subpart B;
RSS-210 issue 8 Annex 1, RSS-Gen issue 4, ICES-003 issue 6:2016





5 Tests summary

Test	Status
Transmitter characteristics	
FCC Part 15, Section 231(a) / RSS-210, Section A1.1.5, Periodic operation requirements	Pass
FCC Part 15, Section 231(a) / RSS-210, Section A1.1.5, Field strength of emissions	Pass
FCC Part 15, Section 231(c) / RSS-210, Section A1.1.3, Occupied bandwidth	Pass
FCC Part 15, Section 207 / RSS-Gen, Section 8.8, Conducted emission	Pass
FCC Part 15, Section 203 / RSS-Gen, Section 8.3, Antenna requirements	Pass

Testing was completed against all relevant requirements of the test standard. The results obtained indicate that the product under test complies in full with the requirements tested.

The test results relate only to the items tested. Pass/ fail decision was based on nominal values.

This test report supersedes the previously issued test report identified by Doc ID:ESSRAD_FCC.28514_rev1.

	Name and Title	Date	Signature
Tested by:	Mr.I. Zilberstein, test engineer	August 29, 2016	
	Mr. K. Zushchuk, test engineer		
Reviewed by:	Mrs. M. Cherniavsky, certification engineer	November 9, 2016	
Approved by:	Mr. M. Nikishin, EMC and Radio group manager	November 9, 2016	

6 EUT description

6.1 General information

The EUT, ES700VPD, is a battery fed panic device, comprises RF module operating at 916.5 MHz and has two configurations: with or without a power supply, in both configurations the EUT includes a non-charging battery.

6.2 Test configuration

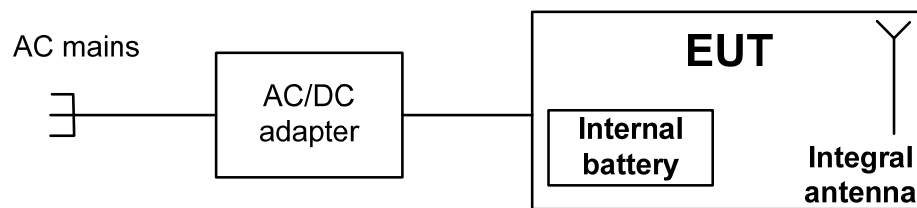

6.3 Changes made in EUT

No changes were implemented in the EUT during testing.



6.4 Transmitter characteristics

Type of equipment							
X	Stand-alone (Equipment with or without its own control provisions)						
	Combined equipment (Equipment where the radio part is fully integrated within another type of equipment)						
	Plug-in card (Equipment intended for a variety of host systems)						
Operating frequencies		916.5 MHz					
Maximum rated output power		At transmitter 50 Ω RF output connector		dBm			
		Field strength at 3 m distance		99.0 dB(μV/m) -peak 81.68 dB(μV/m)-average			
Is transmitter output power variable?		X	No				
			Yes	continuous variable			
				stepped variable with stepsize		dB	
				minimum RF power		dBm	
	maximum RF power		dBm				
Antenna connection							
unique coupling		standard connector		X	integral		
				X	with temporary RF connector without temporary RF connector		
Antenna/s technical characteristics							
Type		Manufacturer		Model number			
Integral		Yipshing		13000			
				Gain			
				-1.8 dBi			
Type of modulation		2FSK					
Transmitter aggregate data rate/s		38.4 kbps					
Transmitter power source							
X	Battery	Nominal rated voltage	3 VDC	Battery type			
X	DC	Nominal rated voltage	5 VDC via AC/DC adapter				
X	AC mains	Nominal rated voltage	120 VAC	Frequency	60 Hz		
Common power source for transmitter and receiver				X	yes		
					no		



Test specification: FCC Part 15, Section 231(a) / RSS-210, Section A1.1.1, Periodic operation requirements			
Test procedure: Supplier declaration			
Test mode: Compliance		Verdict: PASS	
Date(s): 25-Aug-16 - 29-Aug-16			
Temperature: 24.2 °C	Relative Humidity: 48 %	Air Pressure: 1009 hPa	Power: 120 VAC
Remarks:			

7 Transmitter tests according to 47CFR part 15 subpart C requirements

7.1 Periodic operation requirements

7.1.1 General

The EUT was verified for compliance with periodic operation requirements listed below:

- Continuous transmissions such as voice, video and the radio control of toys are not permitted;
- A manually operated transmitter shall employ switch that will automatically deactivate the transmitter within not more than 5 seconds of being released;
- A transmitter activated automatically shall cease transmission within 5 seconds after activation;
- Periodic transmissions, excluding polling or supervision transmissions, at regular predetermined intervals are not permitted;
- Total duration of polling or supervision transmissions, including data, to determine system integrity in security or safety applications shall not exceed 2 seconds per hour;
- Transmission of set-up information for security systems may exceed the transmission duration limits of 5 seconds, provided such transmissions are under the control of a professional installer and do not exceed ten seconds after a manually operated switch is released or a transmitter is activated automatically. Such set-up information may include data.

The rationale for compliance with the above requirements was either test results or supplier declaration. The summary of results is provided in Table 7.1.1.

7.1.2 Test procedure for transmitter shut down test

7.1.2.1 The EUT was set up as shown in Figure 7.1.1.

7.1.2.2 The spectrum analyzer center frequency was adjusted to the EUT carrier, span set to zero and video triggered for transmission.

7.1.2.3 The transmitter was activated either manually or automatically. Once manually operated transmitter was activated, the switch was immediately released.

7.1.2.4 The transmission time was captured and shown in Plot 7.1.1.

7.1.3 Test procedure for measurements of polling / supervision transmission duration

7.1.3.1 The EUT was set up as shown in Figure 7.1.1.

7.1.3.2 The spectrum analyzer center frequency was adjusted to the EUT carrier, span set to zero and video triggered for transmission.

7.1.3.3 The transmission time was captured and shown in Plot 7.1.2, Plot 7.1.3.

Figure 7.1.1 Setup for transmitter shut down test

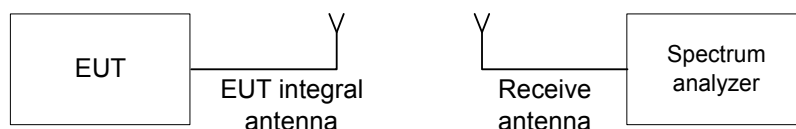



Test specification: FCC Part 15, Section 231(a) / RSS-210, Section A1.1.1, Periodic operation requirements			
Test procedure: Supplier declaration			
Test mode: Compliance		Verdict: PASS	
Date(s): 25-Aug-16 - 29-Aug-16			
Temperature: 24.2 °C	Relative Humidity: 48 %	Air Pressure: 1009 hPa	Power: 120 VAC
Remarks:			

Table 7.1.1 Periodic operation requirements

Requirement	Rationale	Verdict
Continuous transmissions are not permitted	Supplier declaration	Comply
A manually operated transmitter shall be deactivated within not more than 5 seconds of switch being released	Plot 7.1.1	Comply
Transmitter activated automatically shall cease transmission within 5 seconds	NA	NA
Periodic transmissions at regular predetermined intervals are not permitted	Supplier declaration	Comply
Total duration of polling or supervision transmissions shall not exceed 2 seconds per hour	Plot 7.1.2, Plot 7.1.3	Comply
Transmission of set-up information for security systems may exceed the transmission duration limits of 5 seconds, provided such transmissions are under the control of a professional installer and do not exceed ten seconds after a manually operated switch is released or a transmitter is activated automatically. Such set-up information may include data.	Supplier declaration	Comply

Plot 7.1.1 Transmitter shut down test result

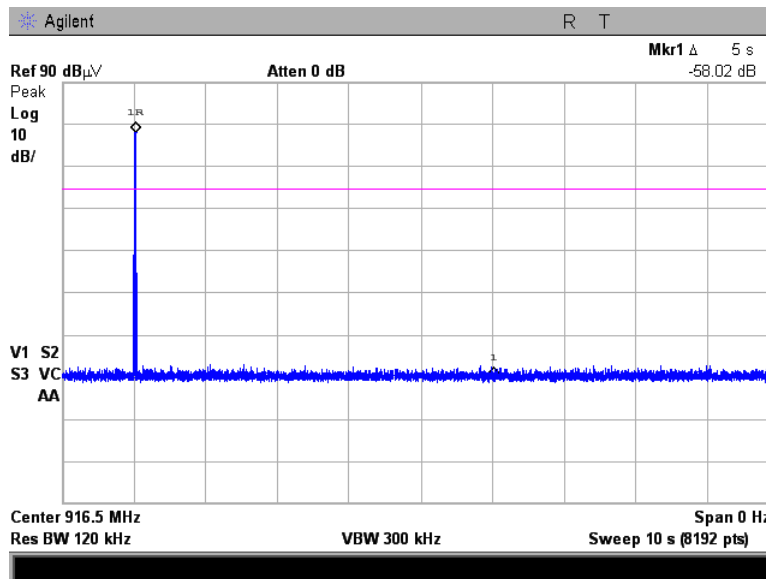



HERMON LABORATORIES

Test specification: FCC Part 15, Section 231(a) / RSS-210, Section A1.1.1, Periodic operation requirements			
Test procedure: Supplier declaration			
Test mode: Compliance		Verdict: PASS	
Date(s): 25-Aug-16 - 29-Aug-16			
Temperature: 24.2 °C	Relative Humidity: 48 %	Air Pressure: 1009 hPa	Power: 120 VAC
Remarks:			

Plot 7.1.2 Polling / supervision transmission duration

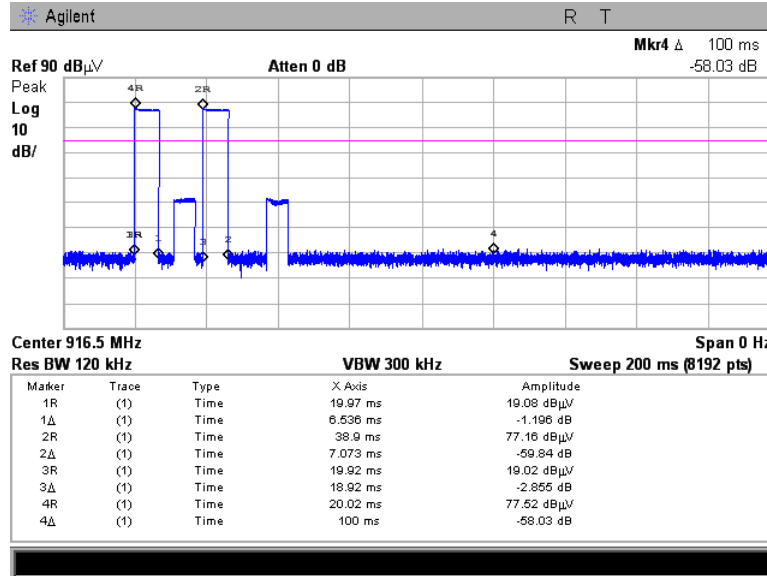

Plot 7.1.3 Polling / supervision transmission period

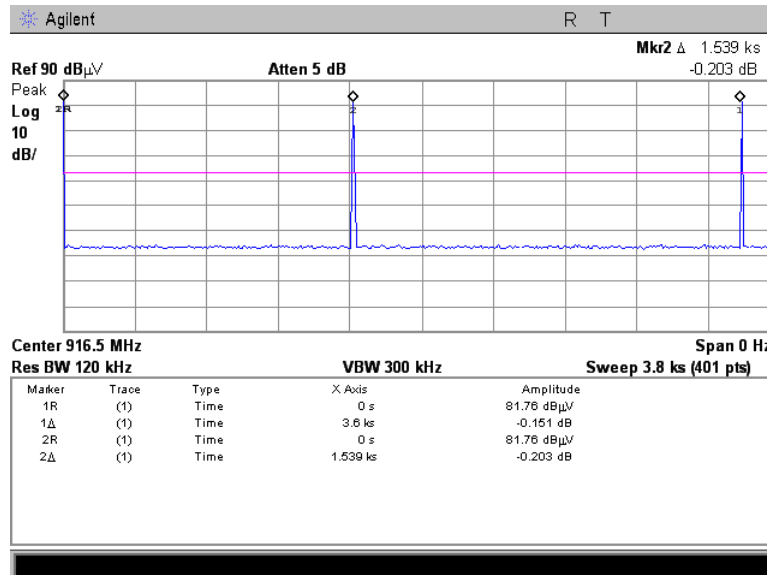



HERMON LABORATORIES

Test specification: FCC Part 15, Section 231(a) / RSS-210, Section A1.1.1, Periodic operation requirements			
Test procedure: Supplier declaration		Verdict: PASS	
Test mode: Compliance			
Date(s): 25-Aug-16 - 29-Aug-16			
Temperature: 24.2 °C	Relative Humidity: 48 %	Air Pressure: 1009 hPa	Power: 120 VAC
Remarks:			

Table 7.1.2 Total duration of polling / supervision transmissions

Duration, ms	Repetition period, ms	Maximum number of transmissions within 1 hour	Total duration within 1 hour, ms
6.54	100	3	40.8
7.07			

Reference numbers of test equipment used

HL 3810	HL 4663						
---------	---------	--	--	--	--	--	--

Full description is given in Appendix A.



Test specification: FCC Part 15, Section 231(b) / RSS-210, Section A1.1.2, Field strength of emissions			
Test procedure: ANSI C63.10 sections 6.5, 6.6			
Test mode: Compliance		Verdict: PASS	
Date(s): 23-Aug-16			
Temperature: 27 °C	Relative Humidity: 42 %	Air Pressure: 1008 hPa	Power: 120 VAC
Remarks:			

7.2 Field strength of emissions

7.2.1 General

This test was performed to measure field strength of fundamental and spurious emissions from the EUT. Specification test limits are given in Table 7.2.1 and Table 7.2.2.

Table 7.2.1 Radiated fundamental emission limits

Fundamental frequency, MHz	Field strength at 3 m, dB(μV/m)	
	Peak	Average
916.5	102.0	82.0

Table 7.2.2 Radiated spurious emissions limits

Frequency, MHz	Field strength at 3 m, dB(μV/m)				
	Within restricted bands			Outside restricted bands	
	Peak	Quasi Peak	Average	Peak	Average
0.009 – 0.090	148.5 – 128.5	NA	128.5 – 108.5**	82.0	62.0
0.090 – 0.110	NA	108.5 – 106.8**	NA		
0.110 – 0.490	126.8 – 113.8	NA	106.8 – 93.8**		
0.490 – 1.705	NA	73.8 – 63.0**	NA		
1.705 – 30.0*		69.5			
30 – 88		40.0			
88 – 216		43.5			
216 – 960		46.0			
960 - 1000		54.0			
Above 1000	74.0	NA	54.0		

*- The limit for 3 m test distance was calculated using the inverse square distance extrapolation factor as follows:

$$Lim_{S_2} = Lim_{S_1} + 40 \log (S_1/S_2),$$

where S_1 and S_2 – standard defined and test distance respectively in meters.

**- The limit decreases linearly with the logarithm of frequency.

Note 1: The fundamental emission limit in dB(μV/m) was calculated as follows:

$$Lim_{AVR} = 20 \times \log(56.81818 \times F - 6136.3636) \text{ - within } 130 - 174 \text{ MHz band;}$$

$$Lim_{AVR} = 20 \times \log(41.6667 \times F - 7083.3333) \text{ - within } 260 - 470 \text{ MHz band,}$$

where F is the carrier frequency in MHz.

The limit for spurious emissions was 20 dB lower than fundamental emission limit.

The above limits provided in terms of average values, peak limit was 20 dB above the average limit.

Note 2: The above field strength limits applied from the lowest radio frequency generated in the device, without going below 9 kHz up to the tenth harmonic of the highest fundamental frequency.



Test specification: FCC Part 15, Section 231(b) / RSS-210, Section A1.1.2, Field strength of emissions			
Test procedure: ANSI C63.10 sections 6.5, 6.6			
Test mode: Compliance		Verdict: PASS	
Date(s): 23-Aug-16			
Temperature: 27 °C	Relative Humidity: 42 %	Air Pressure: 1008 hPa	Power: 120 VAC
Remarks:			

7.2.2 Test procedure for spurious emission field strength measurements in 9 kHz to 30 MHz band

7.2.2.1 The EUT was set up as shown in Figure 7.2.1, energized and the performance check was conducted.

7.2.2.2 The specified frequency range was investigated with antenna connected to spectrum analyzer/ EMI receiver. To find maximum radiation the turntable was rotated 360° and the measuring antenna was rotated around its vertical axis.

7.2.2.3 The worst test results (the lowest margins) were recorded in Table 7.2.3, Table 7.2.5 and shown in the associated plots.

7.2.3 Test procedure for spurious emission field strength measurements above 30 MHz

7.2.3.1 The EUT was set up as shown in Figure 7.2.2, Figure 7.2.3, energized and the performance check was conducted.

7.2.3.2 The specified frequency range was investigated with antenna connected to spectrum analyzer/ EMI receiver. To find maximum radiation the turntable was rotated 360°, the measuring antenna height was changed from 1 to 4 m, its polarization was switched from vertical to horizontal.

7.2.3.3 The worst test results (the lowest margins) were recorded in Table 7.2.3, Table 7.2.5 and shown in the associated plots.

Figure 7.2.1 Setup for spurious emission field strength measurements below 30 MHz

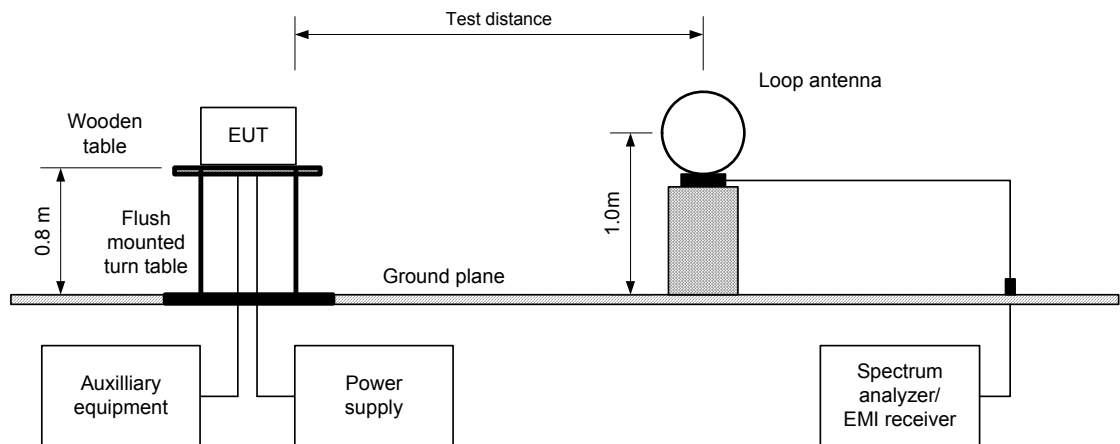



Test specification: FCC Part 15, Section 231(b) / RSS-210, Section A1.1.2, Field strength of emissions			
Test procedure: ANSI C63.10 sections 6.5, 6.6			
Test mode: Compliance		Verdict: PASS	
Date(s): 23-Aug-16			
Temperature: 27 °C	Relative Humidity: 42 %	Air Pressure: 1008 hPa	Power: 120 VAC
Remarks:			

Figure 7.2.2 Setup for spurious emission field strength measurements in 30-1000 MHz

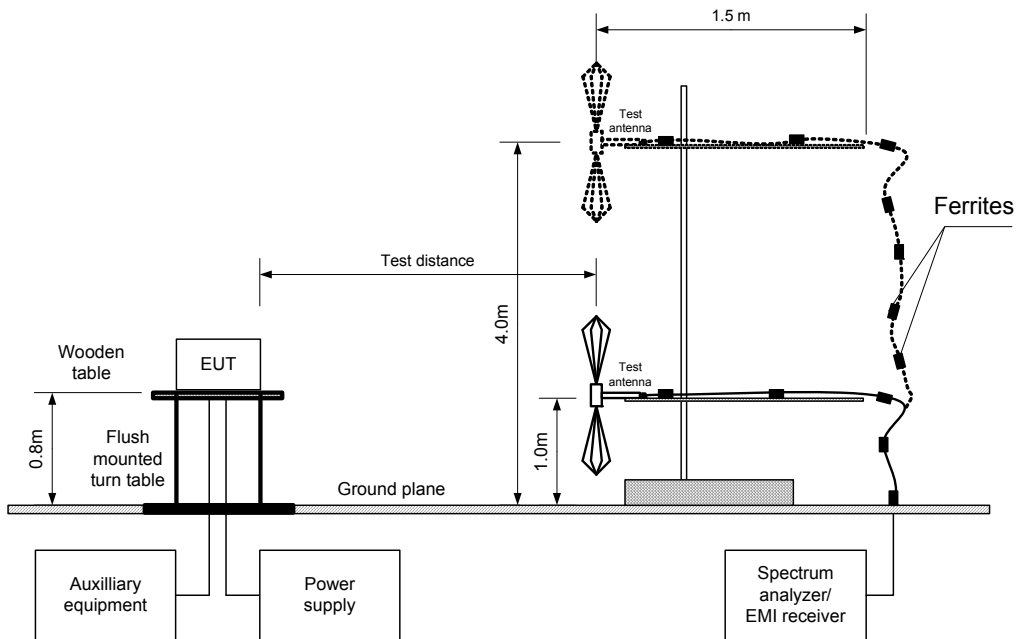
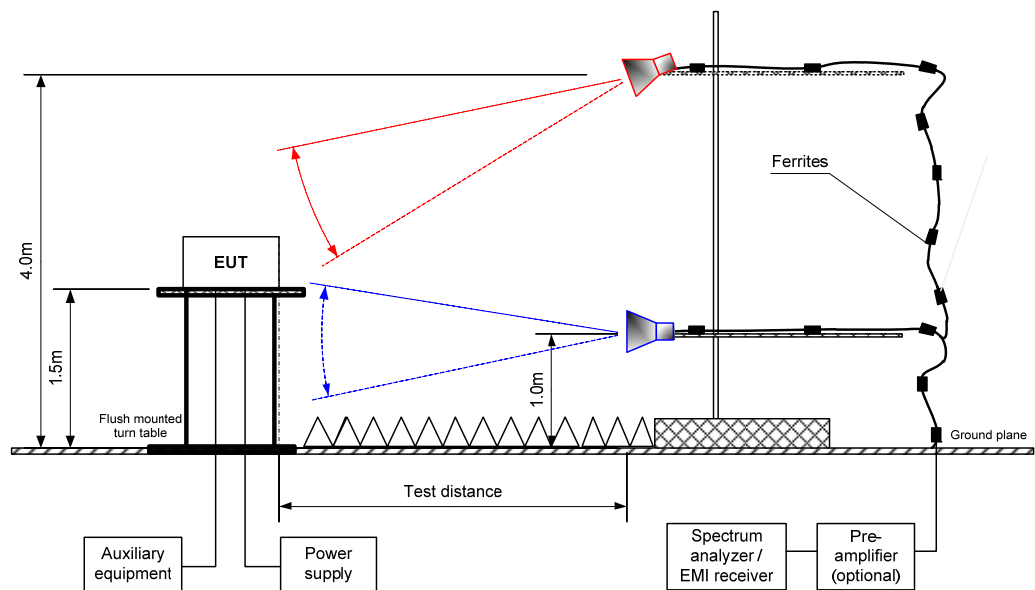

Figure 7.2.3 Setup for spurious emission field strength measurements above 1000 MHz





Test specification: FCC Part 15, Section 231(b) / RSS-210, Section A1.1.2, Field strength of emissions			
Test procedure: ANSI C63.10 sections 6.5, 6.6			
Test mode: Compliance		Verdict: PASS	
Date(s): 23-Aug-16			
Temperature: 27 °C	Relative Humidity: 42 %	Air Pressure: 1008 hPa	Power: 120 VAC
Remarks:			

Table 7.2.3 Field strength of fundamental emission, spurious emissions outside restricted bands and within restricted bands at frequencies above 1 GHz

TEST DISTANCE: 3 m
 EUT POSITION: Typical (Vertical/ Horizontal)
 MODULATION: 2FSK
 MODULATING SIGNAL: ID code
 INVESTIGATED FREQUENCY RANGE: 0.009 -10000 MHz
 DETECTOR USED: Peak
 RESOLUTION BANDWIDTH: 0.2 kHz (9 kHz – 150 kHz)
 9.0 kHz (150 kHz – 30 MHz)
 120 kHz (30 MHz – 1000 MHz)
 1.0 MHz (above 1000 MHz)
 VIDEO BANDWIDTH: ≥ Resolution bandwidth

F, MHz	Antenna		Azimuth, degrees*	Peak field strength			Average field strength				Verdict
	Pol.	Height, m		Measured, dB(μV/m)	Limit, dB(μV/m)	Margin, dB**	Measured, dB(μV/m)	Calculated, dB(μV/m)	Limit, dB(μV/m)	Margin, dB**	
Fundamental emission***											
916.480	H	1.4	270	99.00	102.00	-3.00	99.00	81.68	82.00	-0.32	Pass
Spurious emissions											
54.67	V	1.0	360	24.20	82.00	-57.80	24.20	NA	62.00	-37.80	Pass
72.38	V	1.1	0	21.42	82.00	-60.58	21.42	NA	62.00	-40.58	
389.50	H	1.1	300	34.67	82.00	-47.33	34.67	NA	62.00	-27.33	
458.20	H	1.0	100	33.04	82.00	-48.96	33.04	NA	62.00	-28.96	
1833.01	V	1.5	0	46.99	82.00	-35.01	46.99	29.67	62.00	-32.33	
2749.34	H	1.4	250	42.51	74.00	-31.49	42.51	25.19	54.00	-28.81	
3665.89	H	1.6	350	38.59	74.00	-35.41	38.59	21.27	54.00	-32.73	
4582.63	H	1.5	0	41.36	74.00	-32.64	41.36	24.04	54.00	-29.96	

Measured field strength, (dBμV/m) = meter reading (dBμV) + antenna correction factor (dB/m) +cable loss (dB) – pre-amp (dB), all correction factors were programmed into the spectrum analyzer.

- *- EUT front panel refers to 0 degrees position of turntable.
- ** - Margin, dB =Measured (calculated) value, dB(μV/m)-Limit, dB(μV/m)
- *** Max value was obtained Unom input power voltage.

Table 7.2.4 Average factor calculation

Transmission pulse		Transmission burst		Transmission train duration, ms	Average factor, dB
Duration, ms	Number of pulses in 100 ms	Duration, ms	Period, ms		
7.07+6.54	2	N/A	N/A	N/A	-17.32

*- Average factor was calculated as follows

for pulse train shorter than 100 ms:
$$Average\ factor = 20 \times \log_{10} \left(\frac{Pulse\ duration}{Pulse\ period} \times \frac{Burst\ duration}{Train\ duration} \times Number\ of\ bursts\ within\ pulse\ train \right)$$

for pulse train longer than 100 ms:
$$Average\ factor = 20 \times \log_{10} \left(\frac{Pulse\ duration}{Pulse\ period} \times \frac{Burst\ duration}{100\ ms} \times Number\ of\ bursts\ within\ 100\ ms \right)$$

Reference numbers of test equipment used

HL 0032	HL 0415	HL 0569	HL 2432	HL 4294	HL 4295	HL 4535	HL 4541
HL 4542	HL 4543	HL 4549	HL 4551	HL 4575	HL 4603	HL 4604	HL 4778

Full description is given in Appendix A.



Test specification: FCC Part 15, Section 231(b) / RSS-210, Section A1.1.2, Field strength of emissions			
Test procedure: ANSI C63.10 sections 6.5, 6.6			
Test mode: Compliance		Verdict: PASS	
Date(s): 23-Aug-16			
Temperature: 27 °C	Relative Humidity: 42 %	Air Pressure: 1008 hPa	Power: 120 VAC
Remarks:			

Table 7.2.5 Field strength of emissions below 1 GHz within restricted bands

TEST DISTANCE: 3 m
 EUT POSITION: Typical (Vertical/ Horizontal)
 MODULATION: 2FSK
 MODULATING SIGNAL: ID code
 INVESTIGATED FREQUENCY RANGE: 0.009 – 1000 MHz
 DETECTOR USED: Peak
 RESOLUTION BANDWIDTH: 0.2 kHz (9 kHz – 150 kHz)
 9.0 kHz (150 kHz – 30 MHz)
 120 kHz (30 MHz – 1000 MHz)
 VIDEO BANDWIDTH: ≥ Resolution bandwidth
 TEST ANTENNA TYPE: Active loop (9 kHz – 30 MHz)
 Biconilog (30 MHz – 1000 MHz)

Frequency, MHz	Peak emission, dB(µV/m)	Quasi-peak			Antenna polarization	Antenna height, m	Turn-table position**, degrees	Verdict
		Measured emission, dB(µV/m)	Limit, dB(µV/m)	Margin, dB*				
No emissions were found								Pass

*- Margin = Measured emission - specification limit.
 **- EUT front panel refer to 0 degrees position of turntable.

Reference numbers of test equipment used

HL 0032	HL 0415	HL 0569	HL 4294	HL 4295	HL 4535	HL 4541	HL 4542
HL 4543	HL 4549	HL 4551	HL 4575	HL 4604	HL 4778		

Full description is given in Appendix A.



Test specification: FCC Part 15, Section 231(b) / RSS-210, Section A1.1.2, Field strength of emissions			
Test procedure: ANSI C63.10 sections 6.5, 6.6			
Test mode: Compliance		Verdict: PASS	
Date(s): 23-Aug-16			
Temperature: 27 °C	Relative Humidity: 42 %	Air Pressure: 1008 hPa	Power: 120 VAC
Remarks:			

Table 7.2.6 Restricted bands according to FCC 15, Section 205

MHz	MHz	MHz	MHz	MHz	GHz
0.09 - 0.11	8.37625 - 8.38675	73 - 74.6	399.9 - 410	2690 - 2900	10.6 - 12.7
0.495 - 0.505	8.41425 - 8.41475	74.8 - 75.2	608 - 614	3260 - 3267	13.25 - 13.4
2.1735 - 2.1905	12.290 - 12.293	108 - 121.94	960 - 1240	3332 - 3339	14.47 - 14.5
4.125 - 4.128	12.51975 - 12.52025	123 - 138	1300 - 1427	3345.8 - 3358	15.35 - 16.2
4.17725 - 4.17775	12.57675 - 12.57725	149.9 - 150.05	1435 - 1626.5	3600 - 4400	17.7 - 21.4
4.20725 - 4.20775	13.36 - 13.41	156.52475 - 156.52525	1645.5 - 1646.5	4500 - 5150	22.01 - 23.12
6.215 - 6.218	16.420 - 16.423	156.7 - 156.9	1660 - 1710	5350 - 5460	23.6 - 24
6.26775 - 6.26825	16.69475 - 16.69525	162.0125 - 167.17	1718.8 - 1722.2	7250 - 7750	31.2 - 31.8
6.31175 - 6.31225	16.80425 - 16.80475	167.72 - 173.2	2200 - 2300	8025 - 8500	36.43 - 36.5
8.291 - 8.294	25.5 - 25.67	240 - 285	2310 - 2390	9000 - 9200	Above 38.6
8.362 - 8.366	37.5 - 38.25	322 - 335.4	2483.5 - 2500	9300 - 9500	

Table 7.2.7 Restricted bands according to RSS-Gen, Table 3

MHz	MHz	MHz	MHz	MHz	GHz
0.09 - 0.11	8.291 - 8.294	16.80425 - 16.80475	399.9 - 410	3260 - 3267	10.6 - 12.7
2.1735 - 2.190	8.362 - 8.366	25.5 - 25.67	608 - 614	3332 - 3339	13.25 - 13.4
3.020 - 3.026	8.37625 - 8.38675	37.5 - 38.25	960 - 1427	3345.8 - 3358	14.47 - 14.5
4.125 - 4.128	8.41425 - 8.41475	73 - 74.6	1435 - 1626.5	3500 - 4400	15.35 - 16.2
4.17725 - 4.17775	12.290 - 12.293	74.8 - 75.2	1645.5 - 1646.5	4500 - 5150	17.7 - 21.4
4.20725 - 4.20775	12.51975 - 12.52025	108 - 138	1660 - 1710	5350 - 5460	22.01 - 23.12
5.677 - 5.683	12.57675 - 12.57725	156.52475 - 156.52525	1718.8 - 1722.2	7250 - 7750	23.6 - 24.0
6.215 - 6.218	13.36 - 13.41	156.7 - 156.9	2200 - 2300	8025 - 8500	31.2 - 31.8
6.26775 - 6.26825	16.42 - 16.423	240 - 285	2310 - 2390	9000 - 9200	36.43 - 36.5
6.31175 - 6.31225	16.69475 - 16.69525	322 - 335.4	2655 - 2900	9300 - 9500	Above 38.6



HERMON LABORATORIES

Test specification: FCC Part 15, Section 231(b) / RSS-210, Section A1.1.2, Field strength of emissions			
Test procedure: ANSI C63.10 sections 6.5, 6.6			
Test mode: Compliance		Verdict: PASS	
Date(s): 23-Aug-16			
Temperature: 27 °C	Relative Humidity: 42 %	Air Pressure: 1008 hPa	Power: 120 VAC
Remarks:			

Plot 7.2.1 Radiated emission measurements at the fundamental frequency

TEST SITE: OATS
TEST DISTANCE: 3 m
ANTENNA POLARIZATION: Vertical
EUT POSITION: Typical (Vertical/ Horizontal)
INPUT VOLTAGE: Unom

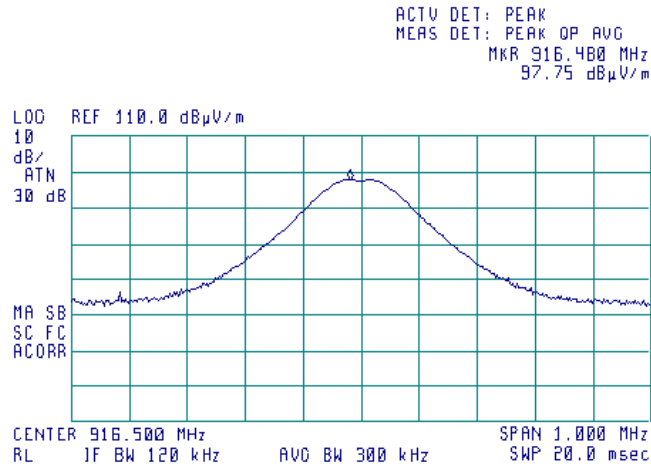

Plot 7.2.2 Radiated emission measurements at the fundamental frequency

TEST SITE: OATS
TEST DISTANCE: 3 m
ANTENNA POLARIZATION: Horizontal
EUT POSITION: Typical (Vertical/ Horizontal)
INPUT VOLTAGE: Unom

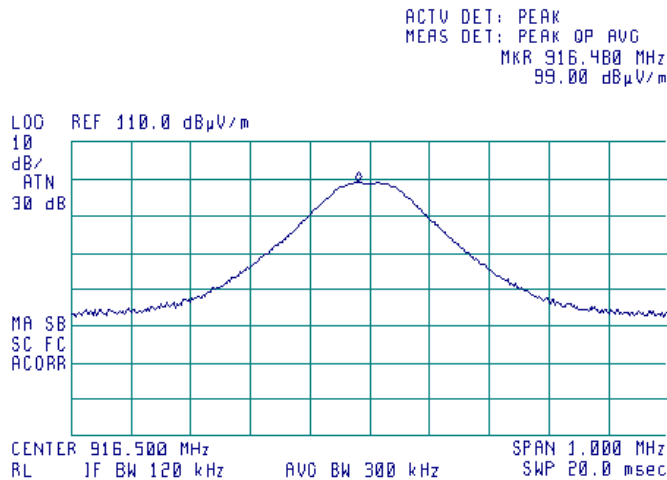



HERMON LABORATORIES

Test specification: FCC Part 15, Section 231(b) / RSS-210, Section A1.1.2, Field strength of emissions			
Test procedure: ANSI C63.10 sections 6.5, 6.6			
Test mode: Compliance		Verdict: PASS	
Date(s): 23-Aug-16			
Temperature: 27 °C	Relative Humidity: 42 %	Air Pressure: 1008 hPa	Power: 120 VAC
Remarks:			

Plot 7.2.3 Radiated emission measurements at the fundamental frequency

TEST SITE: OATS
TEST DISTANCE: 3 m
ANTENNA POLARIZATION: Vertical
EUT POSITION: Typical (Vertical/ Horizontal)
INPUT VOLTAGE: 115%Unom

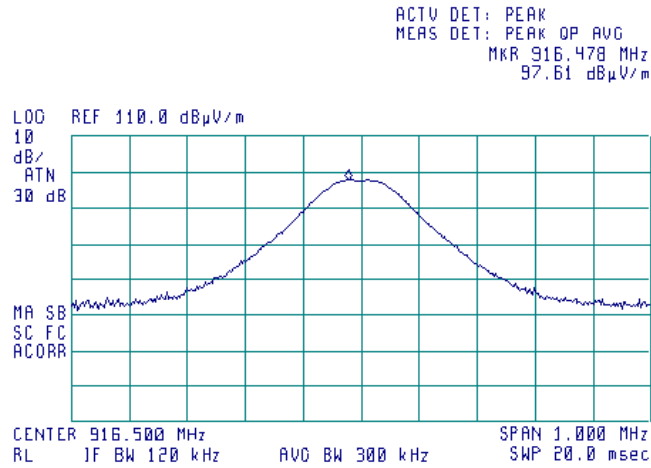

Plot 7.2.4 Radiated emission measurements at the fundamental frequency

TEST SITE: OATS
TEST DISTANCE: 3 m
ANTENNA POLARIZATION: Horizontal
EUT POSITION: Typical (Vertical/ Horizontal)
INPUT VOLTAGE: 115%Unom

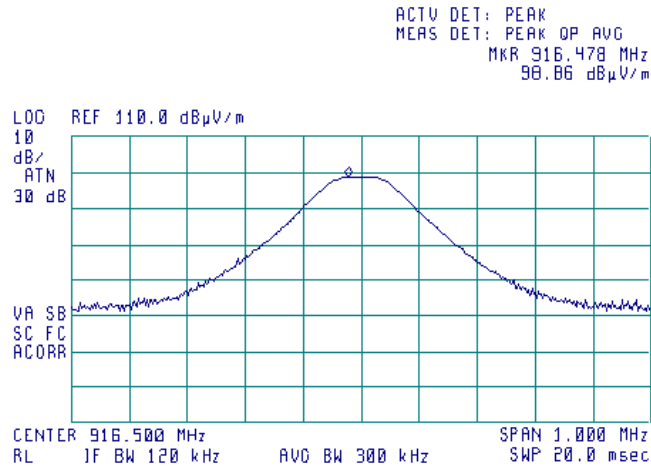



Test specification: FCC Part 15, Section 231(b) / RSS-210, Section A1.1.2, Field strength of emissions			
Test procedure: ANSI C63.10 sections 6.5, 6.6			
Test mode: Compliance		Verdict: PASS	
Date(s): 23-Aug-16			
Temperature: 27 °C	Relative Humidity: 42 %	Air Pressure: 1008 hPa	Power: 120 VAC
Remarks:			

Plot 7.2.5 Radiated emission measurements at the fundamental frequency

TEST SITE: OATS
TEST DISTANCE: 3 m
ANTENNA POLARIZATION: Vertical
EUT POSITION: Typical (Vertical/ Horizontal)
INPUT VOLTAGE: 85%Unom

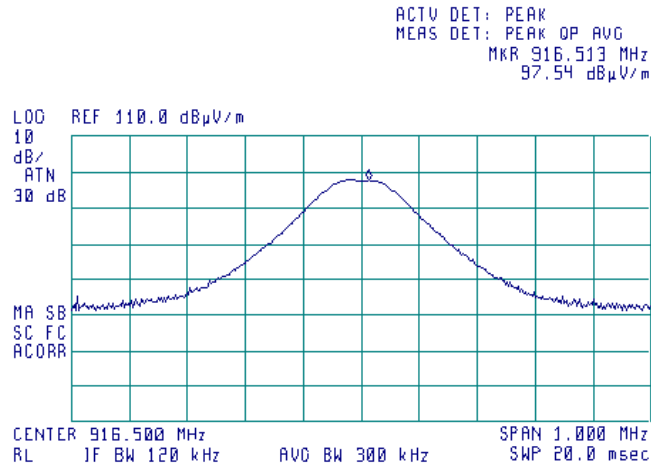

Plot 7.2.6 Radiated emission measurements at the fundamental frequency

TEST SITE: OATS
TEST DISTANCE: 3 m
ANTENNA POLARIZATION: Horizontal
EUT POSITION: Typical (Vertical/ Horizontal)
INPUT VOLTAGE: 85%Unom

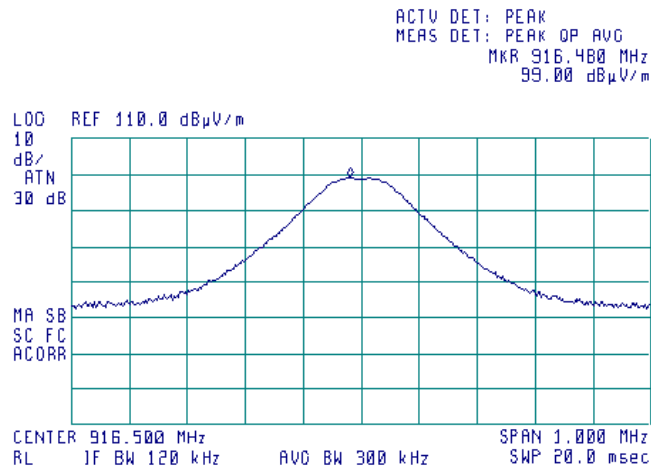



HERMON LABORATORIES

Test specification: FCC Part 15, Section 231(b) / RSS-210, Section A1.1.2, Field strength of emissions			
Test procedure: ANSI C63.10 sections 6.5, 6.6			
Test mode: Compliance	Verdict: PASS		
Date(s): 23-Aug-16			
Temperature: 27 °C	Relative Humidity: 42 %	Air Pressure: 1008 hPa	Power: 120 VAC
Remarks:			

Plot 7.2.7 Radiated emission measurements from 9 to 150 kHz

TEST SITE: Semi anechoic chamber
TEST DISTANCE: 3 m
ANTENNA POLARIZATION: Vertical
EUT POSITION: Typical (Vertical)

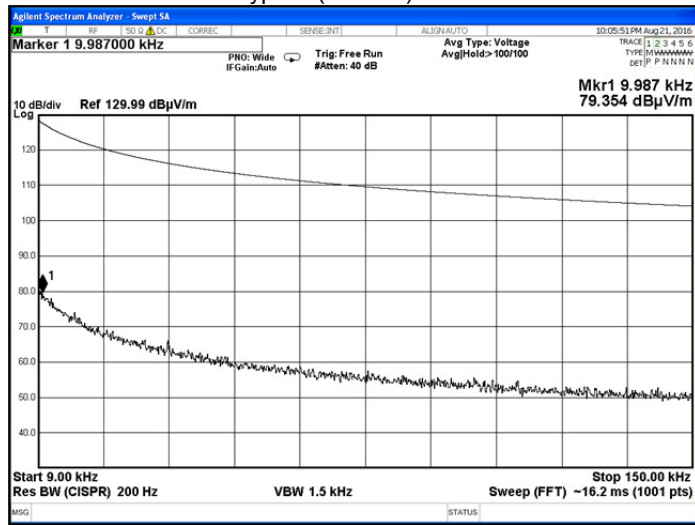

Plot 7.2.8 Radiated emission measurements from 0.15 to 30 MHz

TEST SITE: Semi anechoic chamber
TEST DISTANCE: 3 m
ANTENNA POLARIZATION: Vertical
EUT POSITION: Typical (Vertical)





HERMON LABORATORIES

Test specification: FCC Part 15, Section 231(b) / RSS-210, Section A1.1.2, Field strength of emissions			
Test procedure: ANSI C63.10 sections 6.5, 6.6			
Test mode: Compliance		Verdict: PASS	
Date(s): 23-Aug-16			
Temperature: 27 °C	Relative Humidity: 42 %	Air Pressure: 1008 hPa	Power: 120 VAC
Remarks:			

Plot 7.2.9 Radiated emission measurements from 30 to 1000 MHz

TEST SITE: Semi anechoic chamber
 TEST DISTANCE: 3 m
 ANTENNA POLARIZATION: Vertical and Horizontal
 EUT POSITION: Typical (Vertical)

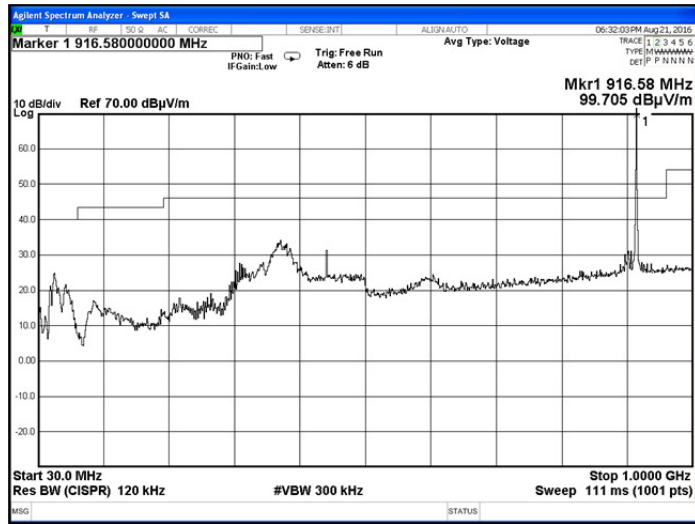

Plot 7.2.10 Radiated emission measurements from 1000 to 10000 MHz

TEST SITE: Semi anechoic chamber
 TEST DISTANCE: 3 m
 ANTENNA POLARIZATION: Vertical and Horizontal
 EUT POSITION: Typical (Vertical)

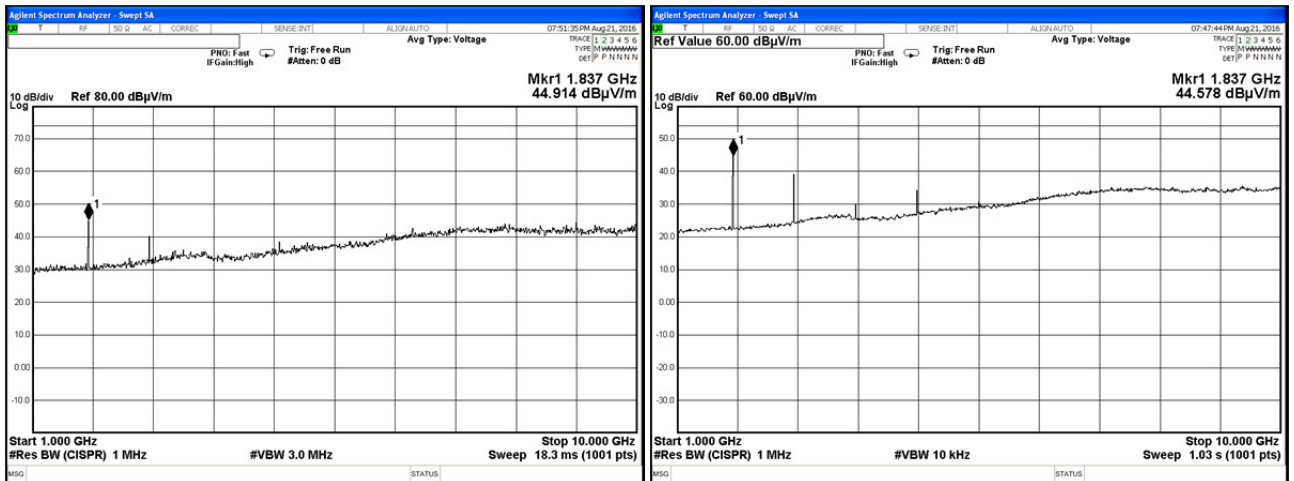



HERMON LABORATORIES

Test specification: FCC Part 15, Section 231(b) / RSS-210, Section A1.1.2, Field strength of emissions			
Test procedure: ANSI C63.10 sections 6.5, 6.6			
Test mode: Compliance	Verdict: PASS		
Date(s): 23-Aug-16			
Temperature: 27 °C	Relative Humidity: 42 %	Air Pressure: 1008 hPa	Power: 120 VAC
Remarks:			

Plot 7.2.11 Radiated emission measurements at the second harmonic frequency

TEST SITE: Semi anechoic chamber
 TEST DISTANCE: 3 m
 ANTENNA POLARIZATION: Vertical
 EUT POSITION: Typical (Vertical)

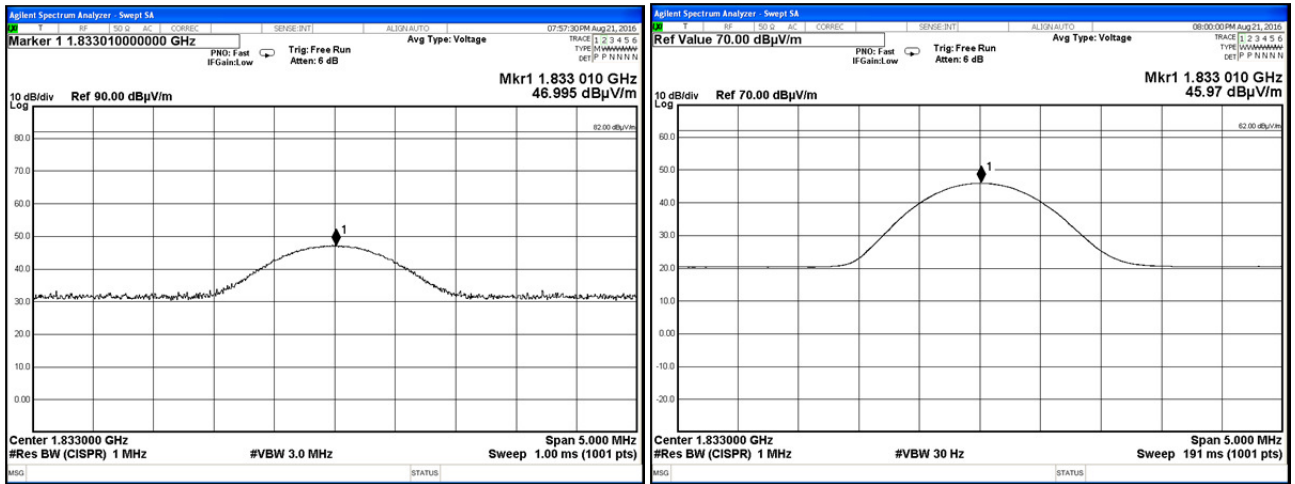

Plot 7.2.12 Radiated emission measurements at the second harmonic frequency

TEST SITE: Semi anechoic chamber
 TEST DISTANCE: 3 m
 ANTENNA POLARIZATION: Horizontal
 EUT POSITION: Typical (Vertical)

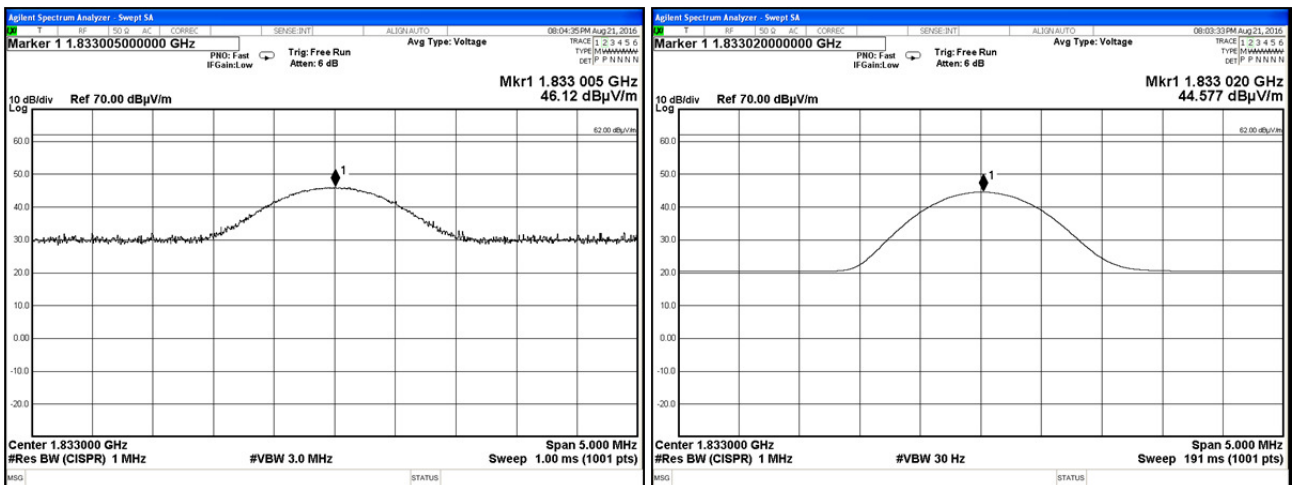



HERMON LABORATORIES

Test specification: FCC Part 15, Section 231(b) / RSS-210, Section A1.1.2, Field strength of emissions			
Test procedure: ANSI C63.10 sections 6.5, 6.6			
Test mode: Compliance		Verdict: PASS	
Date(s): 23-Aug-16			
Temperature: 27 °C	Relative Humidity: 42 %	Air Pressure: 1008 hPa	Power: 120 VAC
Remarks:			

Plot 7.2.13 Radiated emission measurements at the third harmonic frequency

TEST SITE: Semi anechoic chamber
TEST DISTANCE: 3 m
ANTENNA POLARIZATION: Vertical
EUT POSITION: Typical (Vertical)

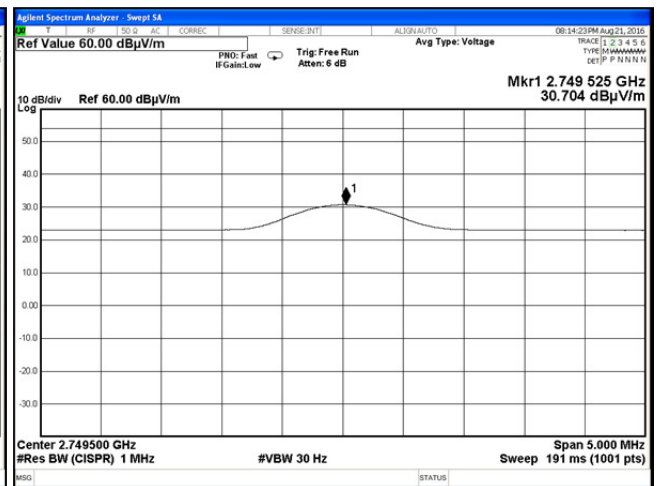
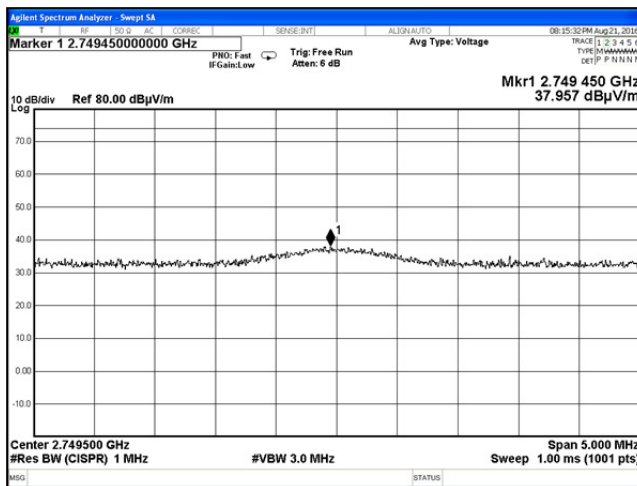

Plot 7.2.14 Radiated emission measurements at the third harmonic frequency

TEST SITE: Semi anechoic chamber
TEST DISTANCE: 3 m
ANTENNA POLARIZATION: Horizontal
EUT POSITION: Typical (Vertical)

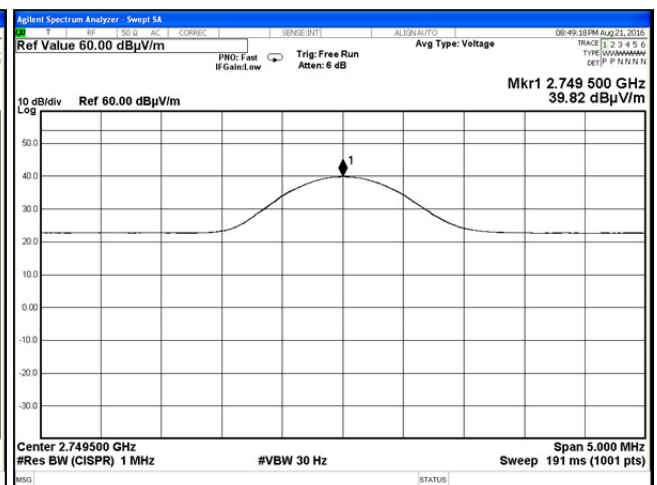
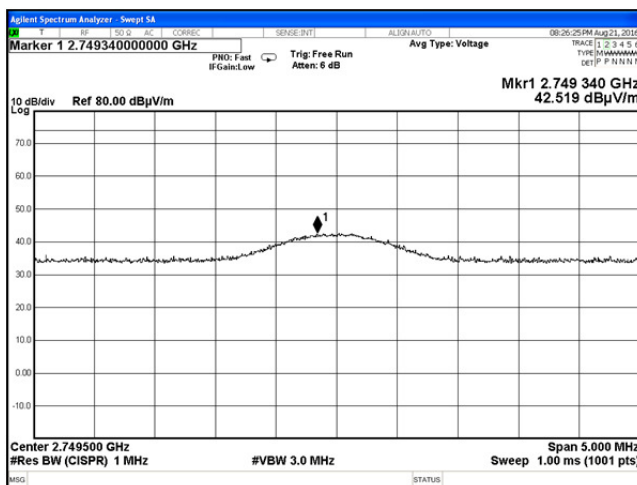



HERMON LABORATORIES

Test specification: FCC Part 15, Section 231(b) / RSS-210, Section A1.1.2, Field strength of emissions			
Test procedure: ANSI C63.10 sections 6.5, 6.6			
Test mode: Compliance		Verdict: PASS	
Date(s): 23-Aug-16			
Temperature: 27 °C	Relative Humidity: 42 %	Air Pressure: 1008 hPa	Power: 120 VAC
Remarks:			

Plot 7.2.15 Radiated emission measurements at the fourth harmonic frequency

TEST SITE: Semi anechoic chamber
TEST DISTANCE: 3 m
ANTENNA POLARIZATION: Vertical
EUT POSITION: Typical (Vertical)

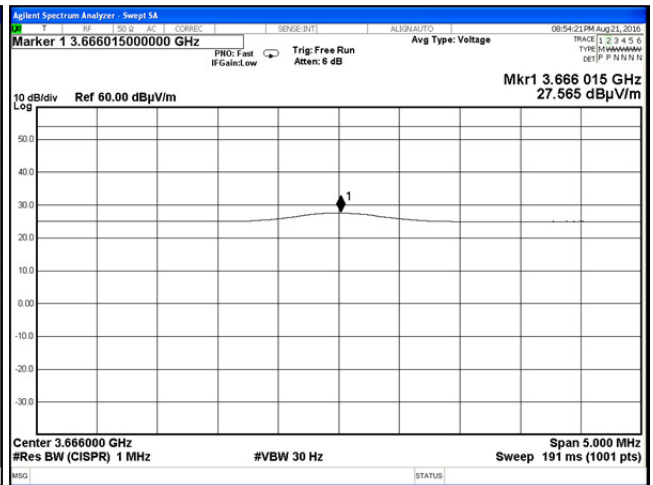
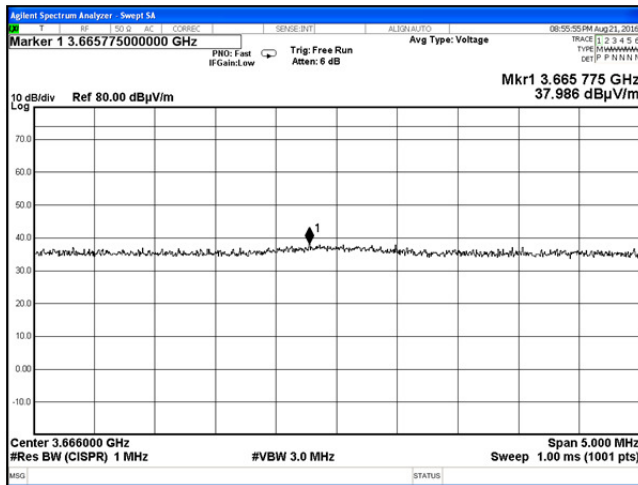

Plot 7.2.16 Radiated emission measurements at the fourth harmonic frequency

TEST SITE: Semi anechoic chamber
TEST DISTANCE: 3 m
ANTENNA POLARIZATION: Horizontal
EUT POSITION: Typical (Vertical)

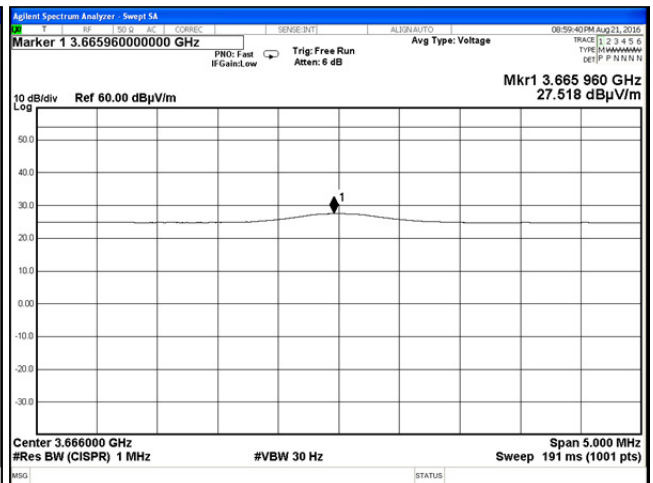
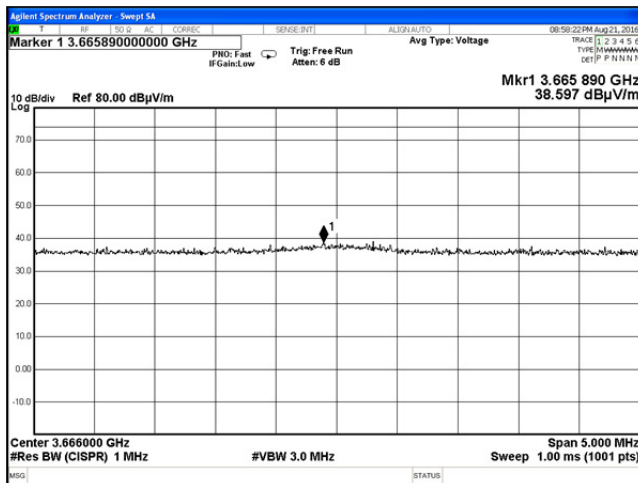



HERMON LABORATORIES

Test specification: FCC Part 15, Section 231(b) / RSS-210, Section A1.1.2, Field strength of emissions			
Test procedure: ANSI C63.10 sections 6.5, 6.6			
Test mode: Compliance		Verdict: PASS	
Date(s): 23-Aug-16			
Temperature: 27 °C	Relative Humidity: 42 %	Air Pressure: 1008 hPa	Power: 120 VAC
Remarks:			

Plot 7.2.17 Radiated emission measurements at the fifth harmonic frequency

TEST SITE: Semi anechoic chamber
TEST DISTANCE: 3 m
ANTENNA POLARIZATION: Vertical
EUT POSITION: Typical (Vertical)

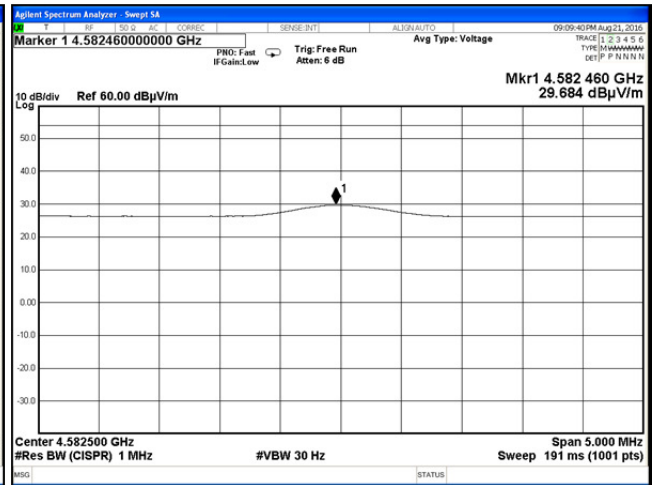
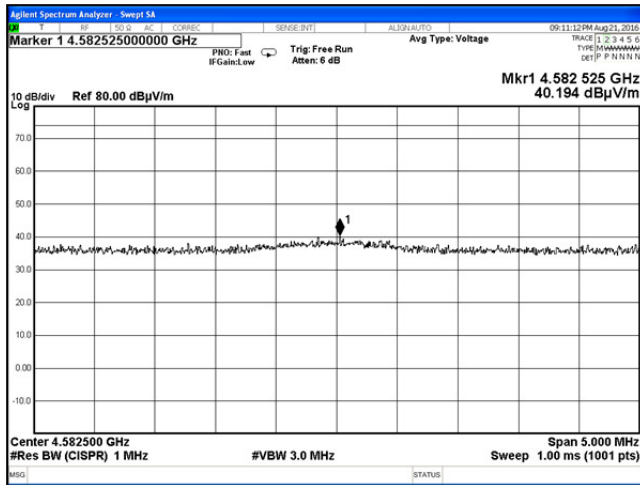

Plot 7.2.18 Radiated emission measurements at the fifth harmonic frequency

TEST SITE: Semi anechoic chamber
TEST DISTANCE: 3 m
ANTENNA POLARIZATION: Horizontal
EUT POSITION: Typical (Vertical)

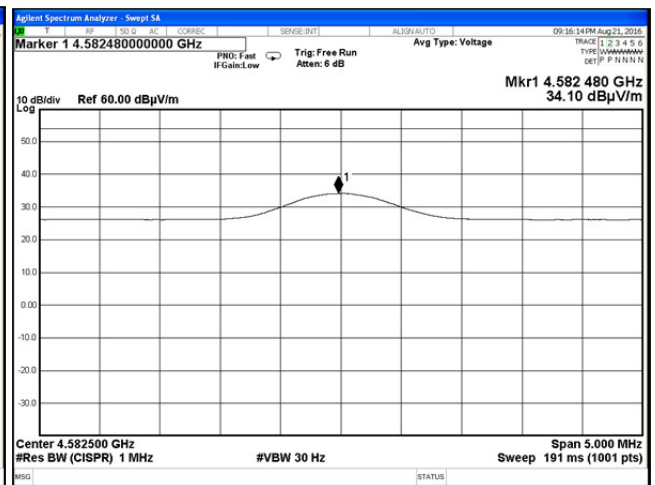
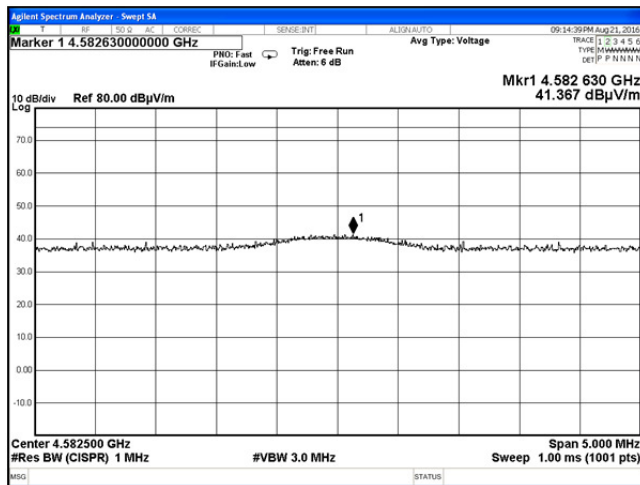



HERMON LABORATORIES

Test specification: FCC Part 15, Section 231(b) / RSS-210, Section A1.1.2, Field strength of emissions			
Test procedure: ANSI C63.10 sections 6.5, 6.6			
Test mode: Compliance		Verdict: PASS	
Date(s): 23-Aug-16			
Temperature: 27 °C	Relative Humidity: 42 %	Air Pressure: 1008 hPa	Power: 120 VAC
Remarks:			

Plot 7.2.19 Transmission pulse duration

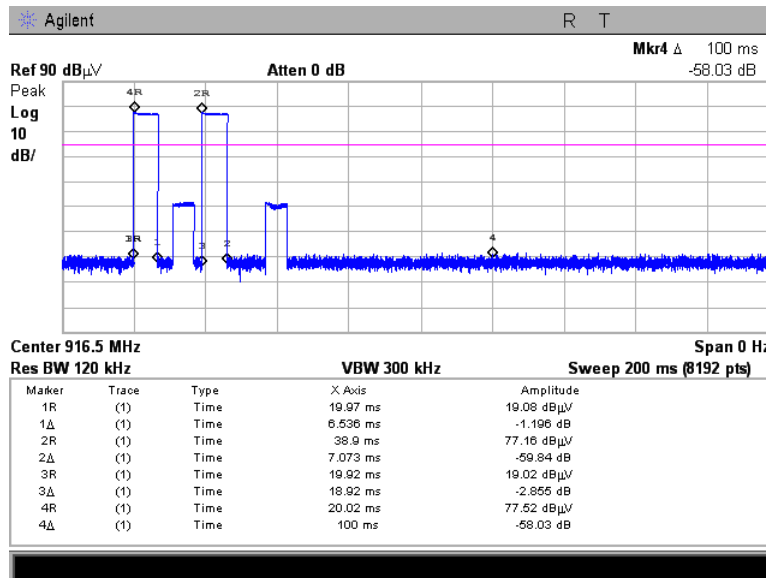

Plot 7.2.20 Transmission pulse period

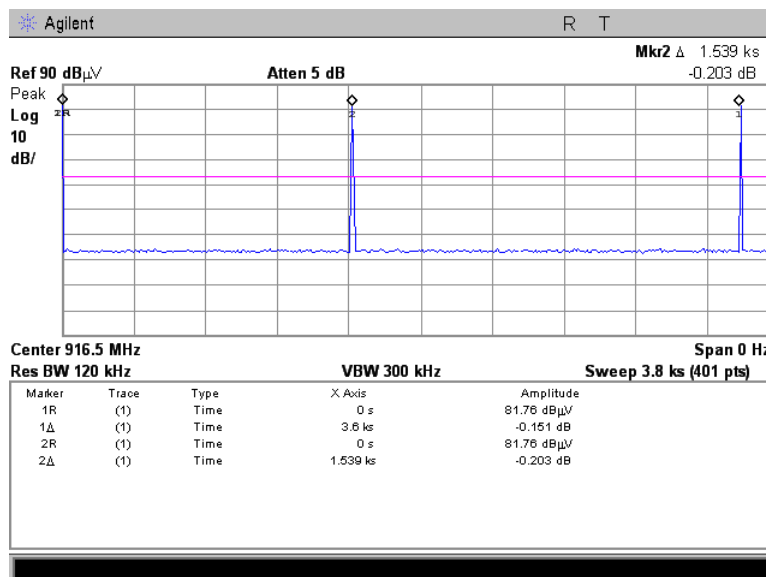



Test specification: FCC Part 15, Section 231(c) / RSS-210, Section A1.1.3, Occupied bandwidth			
Test procedure: ANSI C63.10 section 6.9.2			
Test mode: Compliance		Verdict: PASS	
Date(s): 18-Aug-16			
Temperature: 25 °C	Relative Humidity: 52 %	Air Pressure: 1005 hPa	Power: 120 VAC
Remarks:			

7.3 Occupied bandwidth test

7.3.1 General

This test was performed to measure transmitter occupied bandwidth. Specification test limits are given in Table 7.3.1.

Table 7.3.1 Occupied bandwidth limits

Assigned frequency, MHz	Modulation envelope reference points*, dBc	Maximum allowed bandwidth, % of the carrier frequency
70 - 900	20.0	0.25
Above 900		0.50

*- Modulation envelope reference points provided in terms of attenuation below modulated carrier.

7.3.2 Test procedure

7.3.2.1 The EUT was set up as shown in Figure 7.3.1, energized and its proper operation was checked.

7.3.2.2 The EUT was set to transmit modulated carrier.

7.3.2.3 The transmitter occupied bandwidth was measured with spectrum analyzer as frequency delta between reference points on modulation envelope and provided in Table 7.3.2 and associated plot.

Figure 7.3.1 Occupied bandwidth test setup





Test specification: FCC Part 15, Section 231(c) / RSS-210, Section A1.1.3, Occupied bandwidth			
Test procedure: ANSI C63.10 section 6.9.2			
Test mode: Compliance		Verdict: PASS	
Date(s): 18-Aug-16			
Temperature: 25 °C	Relative Humidity: 52 %	Air Pressure: 1005 hPa	Power: 120 VAC
Remarks:			

Table 7.3.2 Occupied bandwidth test results

DETECTOR USED: Peak hold
 RESOLUTION BANDWIDTH: 1 kHz
 VIDEO BANDWIDTH: 3 kHz
 MODULATION: FSK
 BIT RATE: 38.4kbps
 DETECTOR USED: Peak hold

MODULATION ENVELOPE REFERENCE POINTS: 20 dBc

Carrier frequency, MHz	Occupied bandwidth, kHz	Limit		Margin, kHz	Verdict
		% of the carrier frequency	kHz		
916.5	81.1	0.5	4582.5	-4501.4	Pass

MODULATION ENVELOPE REFERENCE POINTS: 99 %

Carrier frequency, MHz	Occupied bandwidth, kHz	Limit		Margin, kHz	Verdict
		% of the carrier frequency	kHz		
916.5	79.5	0.5	4582.5	-4503.0	Pass

Reference numbers of test equipment used

HL 4136	HL 4274	HL 4575						
---------	---------	---------	--	--	--	--	--	--

Full description is given in Appendix A.



HERMON LABORATORIES

Test specification: FCC Part 15, Section 231(c) / RSS-210, Section A1.1.3, Occupied bandwidth			
Test procedure: ANSI C63.10 section 6.9.2			
Test mode: Compliance		Verdict: PASS	
Date(s): 18-Aug-16			
Temperature: 25 °C	Relative Humidity: 52 %	Air Pressure: 1005 hPa	Power: 120 VAC
Remarks:			

Plot 7.3.1 Occupied bandwidth test result

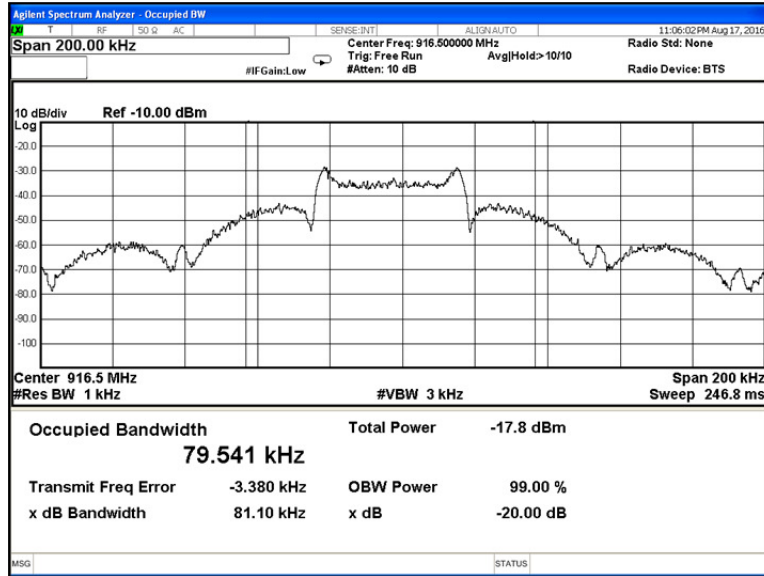



Test specification: FCC Part 15, Section 207 / RSS-Gen, Section 7.2.2, Conducted emission			
Test procedure: ANSI C63.10 section 6.2			
Test mode: Compliance		Verdict: PASS	
Date(s): 23-Aug-16			
Temperature: 25 °C	Relative Humidity: 40 %	Air Pressure: 1008 hPa	Power: 120 VAC
Remarks:			

7.4 Conducted emissions

7.4.1 General

This test was performed to measure common mode conducted emissions at the power port. Specification test limits are given in Table 7.4.1.

Table 7.4.1 Limits for conducted emissions

Frequency, MHz	Class B limit, dB(μV)	
	QP	AVRG
0.15 - 0.5	66 - 56*	56 - 46*
0.5 - 5.0	56	46
5.0 - 30	60	50

* - The limit decreases linearly with the logarithm of frequency.

7.4.2 Test procedure

7.4.2.1 The EUT was set up as shown in Figure 7.4.1 and associated photographs, energized and the performance check was conducted.

7.4.2.2 The measurements were performed at power terminals with the LISN, connected to a spectrum analyzer while unused coaxial connector of the LISN was terminated with 50 Ohm.

7.4.2.3 The position of the device cables was varied to determine maximum emission level.

7.4.2.4 The worst test results (the lowest margins) were recorded in Table 7.4.2 and shown in the associated plots.

Figure 7.4.1 Setup for conducted emission measurements, table-top equipment

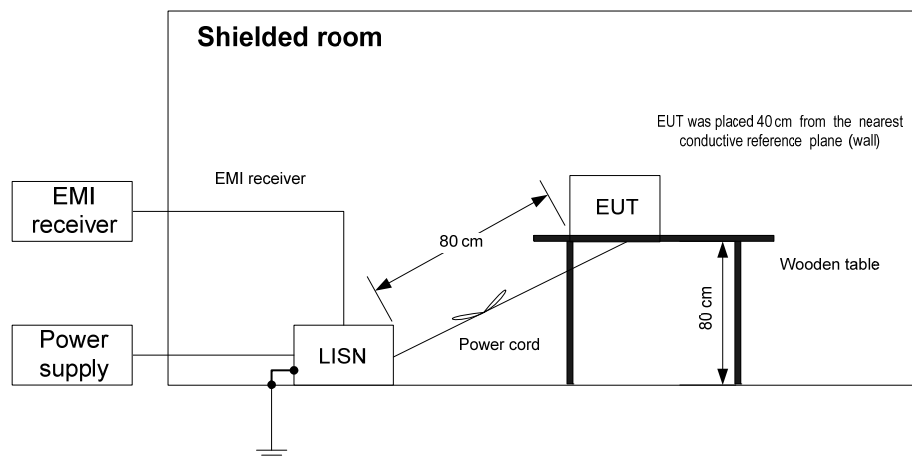



Test specification: FCC Part 15, Section 207 / RSS-Gen, Section 7.2.2, Conducted emission			
Test procedure: ANSI C63.10 section 6.2			
Test mode: Compliance		Verdict: PASS	
Date(s): 23-Aug-16			
Temperature: 25 °C	Relative Humidity: 40 %	Air Pressure: 1008 hPa	Power: 120 VAC
Remarks:			

Table 7.4.2 Conducted emission test results

LINE: AC mains
 EUT OPERATING MODE: Transmit
 EUT SET UP: TABLE-TOP
 TEST SITE: SHIELDED ROOM
 FREQUENCY RANGE: 150 kHz - 30 MHz
 RESOLUTION BANDWIDTH: 9 kHz

Frequency, MHz	Peak emission, dB(µV)	Quasi-peak			Average			Line ID	Verdict
		Measured emission, dB(µV)	Limit, dB(µV)	Margin, dB*	Measured emission, dB(µV)	Limit, dB(µV)	Margin, dB*		
0.150	39.98	32.18	66.00	-33.82	24.36	56.00	-31.64	L1	Pass
0.356	40.81	35.44	58.89	-23.45	22.80	48.89	-26.09		
0.392	36.17	32.61	58.02	-25.41	25.54	48.02	-22.48		
0.770	31.89	26.59	56.00	-29.41	14.81	46.00	-31.19		
1.182	30.72	26.03	56.00	-29.97	13.45	46.00	-32.55		
5.726	34.33	28.72	60.00	-31.28	16.68	50.00	-33.32		
0.150	39.92	31.98	66.00	-34.02	23.74	56.00	-32.26	L2	Pass
0.170	38.91	32.51	65.02	-32.51	12.86	55.02	-42.16		
0.356	37.25	30.22	58.89	-28.67	19.14	48.89	-29.75		
0.392	37.22	32.65	58.02	-25.37	24.75	48.02	-23.27		
1.182	28.12	22.28	56.00	-33.72	10.13	46.00	-35.87		
5.726	28.96	23.43	60.00	-36.57	13.24	50.00	-36.76		

*- Margin = Measured emission - specification limit.

Reference numbers of test equipment used

HL 0447	HL 0787	HL 1513	HL 3612	HL 4756	HL 4778		
---------	---------	---------	---------	---------	---------	--	--

Full description is given in Appendix A.



Test specification: FCC Part 15, Section 207 / RSS-Gen, Section 7.2.2, Conducted emission			
Test procedure: ANSI C63.10 section 6.2			
Test mode: Compliance		Verdict: PASS	
Date(s): 23-Aug-16			
Temperature: 25 °C	Relative Humidity: 40 %	Air Pressure: 1008 hPa	Power: 120 VAC
Remarks:			

Plot 7.4.1 Conducted emission measurements

LINE: L1
EUT OPERATING MODE: Transmit
LIMIT: QUASI-PEAK, AVERAGE
DETECTOR: PEAK



ACTV DET: PEAK
MEAS DET: PEAK QP AVG
MKR 350 kHz
39.24 dBµV

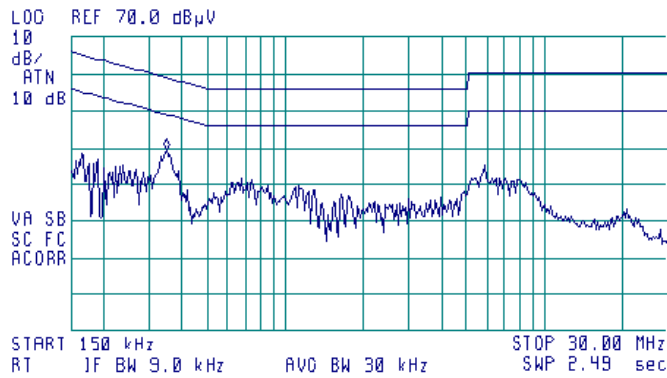

Plot 7.4.2 Conducted emission measurements

LINE: L2
EUT OPERATING MODE: Transmit
LIMIT: QUASI-PEAK, AVERAGE
DETECTOR: PEAK



ACTV DET: PEAK
MEAS DET: PEAK QP AVG
MKR 150 kHz
38.14 dBµV

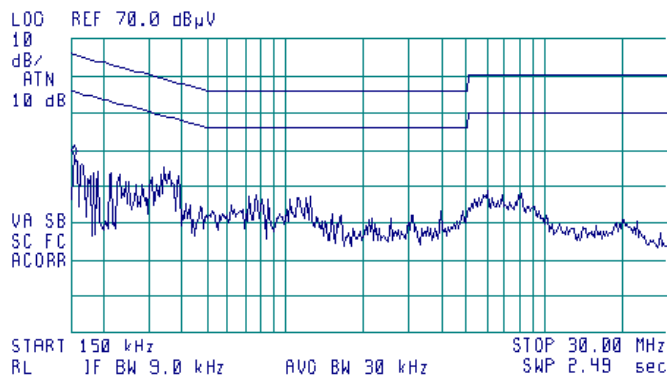



Test specification: FCC Part 15, Section 203 / RSS-Gen, Section 7.1.4, Antenna requirements			
Test procedure: Visual inspection / supplier declaration			
Test mode: Compliance		Verdict: PASS	
Date(s): 03-Aug-16			
Temperature: 26 °C	Relative Humidity: 53 %	Air Pressure: 1007 hPa	Power: 120 VAC
Remarks:			

7.5 Antenna requirements

The EUT was verified for compliance with antenna requirements. A transmitter shall be designed to ensure that no antenna other than that furnished by the responsible party will be used with the device. It may be either permanently attached or employs a unique antenna connector for every antenna proposed for use with the EUT. This requirement does not apply to professionally installed transmitters. The rationale for compliance with the above requirements was either visual inspection results or supplier declaration. The summary of results is provided in Table 7.5.1.

Table 7.5.1 Antenna requirements

Requirement	Rationale	Verdict
The transmitter antenna is permanently attached	Pass	Comply
The transmitter employs a unique antenna connector	NA	
The transmitter requires professional installation	NA	

Photograph 7.5.1 Antenna assembly





8 APPENDIX A Test equipment and ancillaries used for tests

HL No	Description	Manufacturer	Model	Ser. No.	Last Cal./ Check	Due Cal./ Check
0032	Antenna, Biconical, 20 - 200 MHz	Electro-Metrics	BIA 25/30	3577	16-Mar-16	16-Mar-17
0415	Cable, Coax, RF, RG-214, 12.3 m	Hermon Laboratories	CC-3	056	07-Dec-15	07-Dec-16
0447	LISN, 16/2, 300V RMS, 50 Ohm/50 uH + 5 Ohm, STD CISPR 16-1	Hermon Laboratories	LISN 16 - 1	066	13-Oct-15	13-Oct-16
0569	Antenna, Log Periodic, 200 - 1000 MHz	Electro-Metrics	LPA 25/30	1953	17-Mar-16	17-Mar-17
0787	Transient Limiter 9 kHz-200 MHz	Hewlett Packard	11947A	3107A018 77	12-Oct-15	12-Oct-16
1513	Cable RF, 8 m, BNC/BNC	Belden	M17/167 MIL-C-17	1513	08-Sep-15	08-Sep-16
2432	Antenna, Double-Ridged Waveguide Horn 1 to 18 GHz	EMC Test Systems	3115	00027177	28-Mar-16	28-Mar-17
3612	Cable RF, 17.5 m, N type-N type	Teldor	RG-214/U	NA	07-Dec-15	07-Dec-16
3810	Near-Field Probe Set, Hand held, 6 probes	EMC Test Systems	7405	9706-3927	01-Jan-16	01-Jan-17
4136	Shield Box	TESCOM CO., LTD	TC-5916A	5916A000 137	05-Apr-16	05-Apr-17
4274	Test Cable , DC-18 GHz, 1.8 m, SMA/M - N/M	Mini-Circuits	CBL-6FT-SMNM+	70047	30-May-16	30-May-17
4294	Microwave Cable Assembly, 18.0 GHz, 3.4 m, SMA/SMA	Huber-Suhner	Sucoflex P103	NA	07-Dec-15	07-Dec-16
4295	Microwave Cable Assembly, 18.0 GHz, 3.4 m, SMA/SMA	Huber-Suhner	Sucoflex P103	NA	15-Dec-15	15-Dec-16
4535	Microwave Cable Assembly, 6.5 GHz, 5.0 m, N/M type-N/M type	Suhner Switzerland	214-U	NA	30-May-16	30-May-17
4541	Microwave Cable Assembly, 4.0 GHz, 1.0 m, N/M type-N/M type	Suhner Switzerland	214-U	NA	26-Aug-16	26-Aug-17
4542	Amplifier, 9 kHz to 1 GHz, 32 dB gain	Sonoma Instrument	310	0002A056 39	10-Mar-16	10-Mar-17
4543	Broadband preamplifier, 0.5 to 18 GHz, 35 dB gain	Schwarzbeck mess-elektronik	BBV 9718	9718-134	03-Mar-16	03-Mar-17
4549	Cable RF, 6.8 m, N/N - type, up to 3 GHz	Suhner Switzerland	NA	07262	10-Mar-16	10-Mar-17
4551	Cable RF, 6.6 m, N/N - type, up to 18 GHz	Suhner Switzerland	Sucoflex 104E	22200/4E	10-Mar-16	10-Mar-17
4575	EXA Signal Analyzer, 9 kHz - 26.5 GHz	Agilent Technologies	N9010A	MY480301 10	17-Feb-16	17-Mar-17
4603	Horn Antenna, 1 - 18 GHz	Schwarzbeck mess-elektronik	BBHA 9120 D	9120D-611	18-Jun-16	18-Sep-17
4604	Biconilog Antenna, 26 - 2000 MHz	EMCO	3142B	9909-1421	10-May-16	10-May-17
4659	EMC Anechoic Chamber (6.75 x 3.05 x 3.69) m	ETS Euroshield	Ft2000	NA	NA	NA



HERMON LABORATORIES

HL No	Description	Manufacturer	Model	Ser. No.	Last Cal./ Check	Due Cal./ Check
4663	Spectrum Analyzer, 9 kHz - 1.5 GHz	Hewlett Packard	E7401A	US391501 41	23-Aug-15	23-Sep-16
4756	Digital Hygrometer / Thermometer, (0 to +50) deg., (20 to 99) %RH	WESTERN Humidor Corporation	Caliber 4	NA	02-Nov-15	02-Nov-16
4778	EMI Receiver, 9 kHz - 2.9 GHz, System: HL1431, HL4777	Hewlett Packard	8542E	30807A00 262, 3427A001 23	05-Nov-15	05-Nov-16

**9 APPENDIX B Measurement uncertainties****Expanded uncertainty at 95% confidence in Hermon Labs EMC measurements**

Test description	Expanded uncertainty
Conducted emissions with LISN	9 kHz to 150 kHz: ± 3.9 dB 150 kHz to 30 MHz: ± 3.8 dB
Radiated emissions at 10 m measuring distance Horizontal polarization Vertical polarization	Biconilog antenna: ± 5.0 dB Biconical antenna: ± 5.0 dB Log periodic antenna: ± 5.1 dB Double ridged horn antenna: ± 5.3 dB Biconilog antenna: ± 5.5 dB Biconical antenna: ± 5.5 dB Log periodic antenna: ± 5.6 dB Double ridged horn antenna: ± 5.8 dB
Radiated emissions at 3 m measuring distance Horizontal polarization Vertical polarization	Biconilog antenna: ± 5.3 dB Biconical antenna: ± 5.0 dB Log periodic antenna: ± 5.3 dB Double ridged horn antenna: ± 5.3 dB Biconilog antenna: ± 6.0 dB Biconical antenna: ± 5.7 dB Log periodic antenna: ± 6.0 dB Double ridged horn antenna: ± 6.0 dB
Conducted emissions at RF antenna connector	9 kHz to 2.9 GHz: ± 2.6 dB 2.9 GHz to 6.46 GHz: ± 3.5 dB 6.46 GHz to 13.2 GHz: ± 4.3 dB 13.2 GHz to 22.0 GHz: ± 5.0 dB 22.0 GHz to 26.8 GHz: ± 5.5 dB 26.8 GHz to 40.0 GHz: ± 4.8 dB
Duty cycle, timing (Tx ON / OFF) and average factor measurements	± 1.0 %
Occupied bandwidth	± 8.0 %

Hermon Laboratories is accredited by A2LA for calibration according to present requirements of ISO/IEC 17025 and NCSL Z540-1. The accreditation is granted to perform calibration of parameters that are listed in the Scope of Hermon Laboratories Accreditation.

Hermon Laboratories calibrates its reference and transfer standards by calibration laboratories accredited to ISO/IEC 17025 by a mutually recognized Accreditation Body or by a recognized national metrology institute. All reference and transfer standards used in the calibration system are traceable to national or international standards.

In-house calibration of all test and measurement equipment is performed on a regular basis according to Hermon Laboratories calibration procedures, manufacturer calibration/verification procedures or procedures defined in the relevant standards. The Hermon Laboratories test and measurement equipment is calibrated within the tolerances specified by the manufacturers and/or by the relevant standards.

10 APPENDIX C Test laboratory description

Tests were performed at Hermon Laboratories Ltd., which is a fully independent, private, EMC, safety, environmental and telecommunication testing facility.

Hermon Laboratories is recognized and accredited by the Federal Communications Commission (USA) for 1, 2, 15, 18 parts of Code of Federal Regulations 47 (CFR 47), Test Firm Registration Number is 927748, Designation Number is IL1001; registered by Industry Canada for electromagnetic emissions, file number IC 2186A-1 for OATS, certified by VCCI, Japan (the registration numbers are R-808 for OATS, R-1082 for anechoic chamber, G-869 for RE measurements above 1 GHz, C-845 for conducted emissions site, T-1606 for conducted emissions at telecommunication ports). The laboratory is accredited by American Association for Laboratory Accreditation (USA) according to ISO/IEC 17025 for electromagnetic compatibility, product safety, telecommunications testing and environmental simulation (for exact scope please refer to Certificate No. 839.01).

Address: P.O. Box 23, Binyamina 30500, Israel.
Telephone: +972 4628 8001
Fax: +972 4628 8277
e-mail: mail@hermonlabs.com
website: www.hermonlabs.com

Person for contact: Mr. Alex Usoskin, CEO.

11 APPENDIX D Specification references

47CFR part 15: 2015	Radio Frequency Devices.
ANSI C63.10: 2013	American National Standard of Procedures for Compliance Testing of Unlicensed Wireless Devices
ANSI C63.2: 1996	American National Standard for Instrumentation-Electromagnetic Noise and Field Strength, 10 kHz to 40 GHz-Specifications.
ANSI C63.4: 2014	American National Standard for Methods of Measurement of Radio-Noise Emissions from Low-Voltage Electrical and Electronic Equipment in the Range of 9 kHz to 40 GHz
RSS-210 Issue 8: 2010	Low Power Licence- Exempt Radiocommunication Devices
RSS-Gen Issue 4: 2014	General Requirements for Compliance of Radio Apparatus
ICES-003: 2016, Issue 6	Information Technology Equipment (Including Digital Apparatus) – Limits and methods of measurement



12 APPENDIX E Test equipment correction factors

Correction factor
Line impedance stabilization network
Model LISN 16 - 1
Hermon Laboratories, HL 0447

Frequency, kHz	L1, dB	L2, dB
150	0.11	0.09
170	0.10	0.08
200	0.09	0.07
250	0.08	0.07
300	0.07	0.06
350	0.07	0.06
400	0.08	0.05
500	0.07	0.05
600	0.07	0.05
700	0.06	0.06
800	0.07	0.05
900	0.07	0.05
1000	0.07	0.05
1200	0.08	0.05
1500	0.08	0.06
2000	0.08	0.06
2500	0.08	0.06
3000	0.09	0.07
4000	0.09	0.06
5000	0.10	0.08
7000	0.11	0.09
10000	0.14	0.12
15000	0.19	0.17
20000	0.26	0.24
30000	0.45	0.45

The correction factor in dB is to be added to meter readings of an interference analyzer or a spectrum analyzer.



Antenna factor
Biconical antenna
Electro-Metrics, model BIA-25/30
Ser.No.3577, HL 0032

Frequency MHz	Antenna Factor dB(1/m)	Frequency MHz	Antenna Factor dB(1/m)
20	15.1	115	16.7
25	14.6	120	14.1
30	13.7	125	13.1
35	11.8	130	13.0
40	11.4	135	12.9
45	11.7	140	12.7
50	11.4	145	12.5
55	10.5	150	14.3
60	10.3	155	14.8
65	8.9	160	14.7
70	7.6	165	15.1
75	7.3	170	15.6
80	7.3	175	16.5
85	7.8	180	16.7
90	9.4	185	17.3
95	10.6	190	17.9
100	11.8	195	17.6
105	12.5	200	17.9
110	13.7		

Antenna factor in dB (1/m) is to be added to receiver meter reading in dB(μ V) to convert it into field strength in dB(μ V/m).

Antenna factor
Log periodic antenna
Electro-Metrics, model LPA-25/30
Ser.No.1953, HL 0569

Frequency MHz	Antenna Factor dB(1/m)	Frequency MHz	Antenna Factor dB(1/m)
200	15.2	625	25.2
225	15.1	650	25.8
250	16.3	675	27.2
275	17.2	700	27.6
300	19.6	725	27.6
325	18.4	750	27.6
350	19.0	775	28.0
375	20.0	800	28.2
400	20.9	825	29.4
425	21.3	850	29.9
450	22.1	875	30.0
475	22.7	900	30.4
500	23.2	925	30.6
525	23.9	950	30.8
550	24.2	975	31.6
575	24.6	1000	32.1
600	24.7		

Antenna factor in dB(1/m) is to be added to receiver meter reading in dB(μ V) to convert it into field strength in dB(μ V/m).



Antenna factor
Double-ridged guide horn antenna
Model 3115, serial number: 00027177, HL 2432

Frequency, MHz	Antenna factor. dB(1/m)
1000.0	24.7
1500.0	25.7
2000.0	27.8
2500.0	28.9
3000.0	30.7
3500.0	31.8
4000.0	33.0
4500.0	32.8
5000.0	34.2
5500.0	34.9
6000.0	35.2
6500.0	35.4
7000.0	36.3
7500.0	37.3
8000.0	37.5
8500.0	38.0
9000.0	38.3
9500.0	38.3
10000.0	38.7
10500.0	38.7
11000.0	38.9
11500.0	39.5
12000.0	39.5
12500.0	39.4
13000.0	40.5
13500.0	40.8
14000.0	41.5
14500.0	41.3
15000.0	40.2
15500.0	38.7
16000.0	38.5
16500.0	39.8
17000.0	41.9
17500.0	45.8
18000.0	49.1

Antenna factor in dB(1/m) is to be added to receiver meter reading in dB(μ V) to convert it into field strength in dB(μ V/m).



Antenna factor
Horn antenna
Schwarzbeck mess-elektronik, Model BBHA 9120 D, serial number: 9120D-611, HL 4603

Frequency, MHz	Measured antenna factor, dB/m
1000	25.2
1500	25.7
2000	26.1
2500	27.5
3000	28.3
3500	29.0
4000	30.0
4500	30.8
5000	31.9
5500	32.2
6000	33.1
6500	34.6
7000	35.9
7500	36.6
8000	37.2
8500	36.6
9000	36.9
9500	37.5
10000	38.4
10500	39.5
11000	40.3
11500	40.0
12000	39.2
12500	38.7
13000	39.6
13500	40.8
14000	41.6
14500	42.1
15000	41.2
15500	39.1
16000	38.5
16500	39.9
17000	41.0
17500	44.1
18000	55.6

The antenna factor shall be added to receiver reading in dB μ V to obtain field strength in dB μ V/m.



Antenna factor
Biconilog Antenna, 26 - 2000 MHz
EMCO, Model 3142B, serial number: 9909-1421, HL 4604

Frequency, MHz	Measured, dB/m
30	17.9
35	14.8
40	12.1
45	10.0
50	8.7
60	8.1
70	7.3
80	6.6
90	7.6
100	7.9
120	7.0
140	7.7
160	9.6
180	10.0
200	10.2
250	12.7
300	13.4
400	16.7
500	18.2
600	20.2
700	22.0
800	22.7
900	24.1
1000	25.0

The antenna factor shall be added to receiver reading in dB μ V to obtain field strength in dB μ V/m



Cable loss
Cable coax, RG-214, 12.3 m, s/n 056, HL 0415

No.	Frequency, MHz	Cable loss, dB	Measured uncertainty, dB
1	10	0.23	±0.12
2	30	0.44	±0.12
3	50	0.60	±0.12
4	100	0.89	±0.12
5	150	1.11	±0.13
6	200	1.30	±0.13
7	250	1.45	±0.13
8	300	1.61	±0.13
9	400	1.94	±0.13
10	500	2.18	±0.13
11	600	2.45	±0.14
12	700	2.67	±0.14
13	800	2.94	±0.14
14	900	3.16	±0.14
15	1000	3.38	±0.14



Cable loss
Cable coaxial, RG-214/U, N type-N type, 17 m
Teldor, HL 3612

Frequency, MHz	Measured, dB
0.10	0.04
10.0	0.37
20.0	0.54
30.0	0.69
40.0	0.80
50	0.91
60	1.00
70	1.08
80	1.16
90	1.24
100	1.31
150	1.63
200	1.90
250	2.15
300	2.38
350	2.60
400	2.80
450	3.00
500	3.18
550	3.36
600	3.54
650	3.71
700	3.87
750	4.04
800	4.20
850	4.35
900	4.51
950	4.66
1000	4.81



Cable loss
Test cable, Mini-Circuits, S/N 70047, 18 GHz, 1.8 m, SMA/M - N/M
CBL-6FT-SMNM+, HL 4274

Frequency, MHz	Cable loss, dB	Frequency, MHz	Cable loss, dB	Frequency, MHz	Cable loss, dB	Frequency, MHz	Cable loss, dB
10	0.07	4800	1.69	9800	2.62	14800	3.42
30	0.11	4900	1.70	9900	2.63	14900	3.39
50	0.14	5000	1.72	10000	2.64	15000	3.38
100	0.21	5100	1.75	10100	2.64	15100	3.40
200	0.26	5200	1.76	10200	2.66	15200	3.41
300	0.30	5300	1.77	10300	2.67	15300	3.40
400	0.37	5400	1.79	10400	2.68	15400	3.39
500	0.44	5500	1.82	10500	2.68	15500	3.41
600	0.49	5600	1.85	10600	2.70	15600	3.44
700	0.54	5700	1.86	10700	2.71	15700	3.46
800	0.58	5800	1.87	10800	2.73	15800	3.45
900	0.63	5900	1.91	10900	2.74	15900	3.47
1000	0.67	6000	1.94	11000	2.76	16000	3.51
1100	0.71	6100	1.97	11100	2.77	16100	3.56
1200	0.75	6200	1.98	11200	2.78	16200	3.55
1300	0.78	6300	1.99	11300	2.79	16300	3.54
1400	0.81	6400	2.02	11400	2.80	16400	3.57
1500	0.85	6500	2.05	11500	2.82	16500	3.62
1600	0.88	6600	2.06	11600	2.83	16600	3.61
1700	0.91	6700	2.06	11700	2.84	16700	3.60
1800	0.94	6800	2.08	11800	2.85	16800	3.62
1900	0.97	6900	2.10	11900	2.87	16900	3.68
2000	1.00	7000	2.12	12000	2.88	17000	3.70
2100	1.03	7100	2.12	12100	2.89	17100	3.68
2200	1.06	7200	2.13	12200	2.90	17200	3.70
2300	1.08	7300	2.16	12300	2.92	17300	3.80
2400	1.11	7400	2.19	12400	2.94	17400	3.84
2500	1.14	7500	2.22	12500	2.95	17500	3.83
2600	1.16	7600	2.23	12600	2.96	17600	3.83
2700	1.19	7700	2.26	12700	2.98	17700	3.86
2800	1.21	7800	2.30	12800	3.00	17800	3.86
2900	1.27	7900	2.33	12900	3.02	17900	3.80
3000	1.29	8000	2.35	13000	3.03	18000	3.79
3100	1.32	8100	2.37	13100	3.06		
3200	1.35	8200	2.41	13200	3.08		
3300	1.37	8300	2.44	13300	3.09		
3400	1.38	8400	2.47	13400	3.10		
3500	1.41	8500	2.48	13500	3.13		
3600	1.43	8600	2.51	13600	3.17		
3700	1.46	8700	2.53	13700	3.17		
3800	1.47	8800	2.55	13800	3.18		
3900	1.49	8900	2.56	13900	3.22		
4000	1.52	9000	2.57	14000	3.26		
4100	1.55	9100	2.58	14100	3.28		
4200	1.56	9200	2.59	14200	3.30		
4300	1.58	9300	2.59	14300	3.35		
4400	1.60	9400	2.60	14400	3.39		
4500	1.63	9500	2.60	14500	3.39		
4600	1.65	9600	2.61	14600	3.39		
4700	1.67	9700	2.61	14700	3.41		



Cable loss
Microwave Cable Assembly, 18.0 GHz, 3.4 m, SMA/SMA, Huber-Suhner,
Sucoflex P103, HL 4294

Frequency, MHz	Cable loss, dB	Frequency, MHz	Cable loss, dB	Frequency, MHz	Cable loss, dB	Frequency, MHz	Cable loss, dB
10	0.11	4900	2.09	10000	2.90	15100	3.61
30	0.17	5000	2.10	10100	2.92	15200	3.67
50	0.22	5100	2.14	10200	2.95	15300	3.63
100	0.30	5200	2.16	10300	2.96	15400	3.64
200	0.42	5300	2.17	10400	2.99	15500	3.68
300	0.51	5400	2.19	10500	2.99	15600	3.71
400	0.59	5500	2.19	10600	3.03	15700	3.74
500	0.66	5600	2.22	10700	3.03	15800	3.71
600	0.72	5700	2.24	10800	3.04	15900	3.74
700	0.77	5800	2.23	10900	3.05	16000	3.71
800	0.82	5900	2.26	11000	3.09	16100	3.73
900	0.88	6000	2.27	11100	3.07	16200	3.76
1000	0.93	6100	2.26	11200	3.08	16300	3.82
1100	0.98	6200	2.29	11300	3.11	16400	3.90
1200	1.02	6300	2.30	11400	3.12	16500	3.81
1300	1.06	6400	2.34	11500	3.11	16600	3.88
1400	1.10	6500	2.34	11600	3.15	16700	3.87
1500	1.14	6600	2.36	11700	3.16	16800	3.89
1600	1.19	6700	2.36	11800	3.18	16900	3.95
1700	1.23	6800	2.39	11900	3.19	17000	4.02
1800	1.27	6900	2.39	12000	3.23	17100	4.04
1900	1.30	7000	2.44	12100	3.25	17200	3.99
2000	1.35	7100	2.46	12200	3.22	17300	4.03
2100	1.38	7200	2.44	12300	3.25	17400	4.03
2200	1.42	7300	2.48	12400	3.25	17500	4.06
2300	1.45	7400	2.47	12500	3.28	17600	4.05
2400	1.48	7500	2.48	12600	3.27	17700	4.12
2500	1.51	7600	2.50	12700	3.27	17800	4.14
2600	1.55	7700	2.53	12800	3.30	17900	4.18
2700	1.59	7800	2.56	12900	3.30	18000	4.14
2800	1.62	7900	2.55	13000	3.27		
2900	1.65	8000	2.56	13100	3.32		
3000	1.66	8100	2.56	13200	3.32		
3100	1.69	8200	2.57	13300	3.32		
3200	1.71	8300	2.59	13400	3.35		
3300	1.74	8400	2.62	13500	3.38		
3400	1.76	8500	2.67	13600	3.39		
3500	1.78	8600	2.65	13700	3.42		
3600	1.80	8700	2.68	13800	3.47		
3700	1.85	8800	2.68	13900	3.45		
3800	1.88	8900	2.68	14000	3.49		
3900	1.90	9000	2.74	14100	3.50		
4000	1.91	9100	2.74	14200	3.55		
4100	1.93	9200	2.76	14300	3.59		
4200	1.96	9300	2.78	14400	3.58		
4300	1.97	9400	2.79	14500	3.56		
4400	1.99	9500	2.80	14600	3.57		
4500	2.02	9600	2.83	14700	3.57		
4600	2.02	9700	2.84	14800	3.57		
4700	2.04	9800	2.86	14900	3.64		
4800	2.05	9900	2.92	15000	3.64		



Cable loss
Microwave Cable Assembly, 18.0 GHz, 3.4 m, SMA/SMA, Huber-Suhner, S/N 4295,
Sucoflex P103, HL 4295

Frequency, MHz	Cable loss, dB	Frequency, MHz	Cable loss, dB	Frequency, MHz	Cable loss, dB	Frequency, MHz	Cable loss, dB
10	0.11	5000	2.09	10200	2.97	15400	3.63
30	0.18	5100	2.12	10300	3.01	15500	3.65
50	0.23	5200	2.13	10400	3.00	15600	3.63
100	0.31	5300	2.16	10500	3.05	15700	3.64
200	0.38	5400	2.19	10600	3.09	15800	3.64
300	0.43	5500	2.21	10700	3.05	15900	3.66
400	0.52	5600	2.21	10800	3.09	16000	3.71
500	0.60	5700	2.24	10900	3.10	16100	3.67
600	0.67	5800	2.24	11000	3.08	16200	3.71
700	0.72	5900	2.25	11100	3.11	16300	3.70
800	0.78	6000	2.27	11200	3.12	16400	3.71
900	0.83	6100	2.25	11300	3.12	16500	3.72
1000	0.89	6200	2.29	11400	3.20	16600	3.84
1100	0.94	6300	2.34	11500	3.16	16700	3.78
1200	0.98	6400	2.37	11600	3.16	16800	3.85
1300	1.03	6500	2.33	11700	3.20	16900	3.88
1400	1.06	6600	2.34	11800	3.19	17000	3.85
1500	1.11	6700	2.39	11900	3.21	17100	3.88
1600	1.14	6800	2.46	12000	3.28	17200	3.92
1700	1.19	6900	2.45	12100	3.23	17300	3.90
1800	1.22	7000	2.44	12200	3.26	17400	4.00
1900	1.26	7100	2.43	12300	3.30	17500	4.02
2000	1.30	7200	2.44	12400	3.25	17600	4.00
2100	1.34	7300	2.51	12500	3.26	17700	3.96
2200	1.37	7400	2.54	12600	3.30	17800	4.01
2300	1.40	7500	2.49	12700	3.26	17900	4.02
2400	1.44	7600	2.52	12800	3.34	18000	4.08
2500	1.47	7700	2.59	12900	3.37		
2600	1.50	7800	2.57	13000	3.30		
2700	1.55	7900	2.55	13100	3.35		
2800	1.58	8000	2.57	13200	3.31		
2900	1.60	8100	2.58	13300	3.33		
3000	1.63	8200	2.64	13400	3.42		
3100	1.64	8300	2.70	13500	3.43		
3200	1.67	8400	2.65	13600	3.40		
3300	1.69	8500	2.66	13700	3.47		
3400	1.73	8600	2.68	13800	3.45		
3500	1.74	8700	2.70	13900	3.43		
3600	1.76	8800	2.74	14000	3.52		
3700	1.79	8900	2.74	14100	3.51		
3800	1.82	9000	2.76	14200	3.54		
3900	1.85	9100	2.82	14300	3.55		
4000	1.87	9200	2.79	14400	3.52		
4100	1.90	9300	2.82	14500	3.52		
4200	1.92	9400	2.83	14600	3.56		
4300	1.93	9500	2.83	14700	3.55		
4400	1.94	9600	2.86	14800	3.55		
4500	1.97	9700	2.93	14900	3.59		
4600	1.99	9800	2.89	15000	3.56		
4700	2.01	9900	2.91	15100	3.59		
4800	2.02	10000	2.94	15200	3.59		
4900	2.04	10100	2.94	15300	3.59		



Cable loss
Microwave Cable Assembly, 6.5 GHz, 5.0 m, N/M type-N/M type
Suhner Switzerland, HL 4535

Frequency, MHz	Cable loss, dB	Frequency, MHz	Cable loss, dB	Frequency, MHz	Cable loss, dB
10	0.10	1700	1.79	4400	3.53
15	0.13	1800	1.86	4500	3.60
20	0.15	1900	1.93	4600	3.72
30	0.18	2000	2.00	4700	3.80
40	0.21	2100	2.06	4800	3.87
50	0.24	2200	2.13	4900	3.94
60	0.26	2300	2.19	5000	3.99
70	0.29	2400	2.25	5100	4.06
80	0.31	2500	2.32	5200	4.12
90	0.33	2600	2.38	5300	4.17
100	0.35	2700	2.45	5400	4.25
150	0.43	2800	2.51	5500	4.31
200	0.50	2900	2.57	5600	4.40
300	0.63	3000	2.64	5700	4.47
400	0.74	3100	2.73	5800	4.54
500	0.85	3200	2.79	5900	4.64
600	0.94	3300	2.86	6000	4.73
700	1.03	3400	2.91	6100	4.79
800	1.12	3500	2.97	6200	4.89
900	1.20	3600	3.02	6300	5.00
1000	1.28	3700	3.07	6400	5.06
1100	1.35	3800	3.14	6500	5.13
1200	1.43	3900	3.20		
1300	1.50	4000	3.25		
1400	1.58	4100	3.32		
1500	1.65	4200	3.38		
1600	1.72	4300	3.46		



Cable loss
Microwave Cable Assembly, 4.0 GHz, 1.0 m, N/M type-N/M type
Suhner Switzerland, HL 4541

Frequency, MHz	Cable loss, dB	Frequency, MHz	Cable loss, dB
10	0.02	1700	0.45
15	0.03	1800	0.46
20	0.03	1900	0.48
30	0.04	2000	0.49
40	0.04	2100	0.52
50	0.05	2200	0.54
60	0.06	2300	0.55
70	0.06	2400	0.56
80	0.07	2500	0.58
90	0.07	2600	0.59
100	0.08	2700	0.61
150	0.10	2800	0.63
200	0.12	2900	0.64
300	0.15	3000	0.67
400	0.18	3100	0.70
500	0.20	3200	0.74
600	0.23	3300	0.77
700	0.25	3400	0.80
800	0.28	3500	0.82
900	0.30	3600	0.86
1000	0.31	3700	0.88
1100	0.33	3800	0.94
1200	0.35	3900	0.95
1300	0.37	4000	0.99
1400	0.39		
1500	0.41		
1600	0.43		



13 APPENDIX F Abbreviations and acronyms

A	ampere
AC	alternating current
A/m	ampere per meter
AM	amplitude modulation
AVRG	average (detector)
cm	centimeter
dB	decibel
dBm	decibel referred to one milliwatt
dB(μ V)	decibel referred to one microvolt
dB(μ V/m)	decibel referred to one microvolt per meter
dB(μ A)	decibel referred to one microampere
DC	direct current
EIRP	equivalent isotropically radiated power
ERP	effective radiated power
EUT	equipment under test
F	frequency
GHz	gigahertz
GND	ground
H	height
HL	Hermon laboratories
Hz	hertz
k	kilo
kHz	kilohertz
LO	local oscillator
m	meter
MHz	megahertz
min	minute
mm	millimeter
ms	millisecond
μ s	microsecond
NA	not applicable
NB	narrow band
OATS	open area test site
Ω	Ohm
PM	pulse modulation
PS	power supply
ppm	part per million (10^{-6})
QP	quasi-peak
RE	radiated emission
RF	radio frequency
rms	root mean square
Rx	receive
s	second
T	temperature
Tx	transmit
V	volt
WB	wideband

END OF DOCUMENT