

| | | | | | |
|---|--|--|---|--|--|
| Prüfbericht-Nr.: <i>Test report no.:</i> | CN22C1SP(P15C-BLE) 001 | Auftrags-Nr.: <i>Order no.:</i> | 238523973 | Seite 1 von 27 Page 1 of 27 | |
| Kunden-Referenz-Nr.: <i>Client reference no.:</i> | N/A | Auftragsdatum: <i>Order date:</i> | 2021-12-23 | | |
| Auftraggeber: <i>Client:</i> | Atech OEM Inc. 7F, AAeon Building, No. 43, Sec. 4 Keelung Rd. Taipei City, Taiwan | | | | |
| Prüfgegenstand: <i>Test item:</i> | Bluetooth v5.0 BLE Single Mode Module | | | | |
| Bezeichnung / Typ-Nr.: <i>Identification / Type no.:</i> | BL5032 | | | | |
| Auftrags-Inhalt: <i>Order content:</i> | FCC Part 15C Test report (BLE) | | | | |
| Prüfgrundlage: <i>Test specification:</i> | FCC 47CFR Part 15: Subpart C Section 15.247 | | | | |
| Wareneingangsdatum: <i>Date of sample receipt:</i> | 2022-02-17 | | | | |
| Prüfmuster-Nr.: <i>Test sample no.:</i> | A003213909-001 A003213909-003 | | | | |
| Prüfzeitraum: <i>Testing period:</i> | 2022-03-16 - 2022-03-23 | | | | |
| Ort der Prüfung: <i>Place of testing:</i> | EMC/RF Taipei Testing Site | | | | |
| Prüflaboratorium: <i>Testing laboratory:</i> | Taipei Testing Laboratories | | | | |
| Prüfergebnis*: <i>Test result*:</i> | Pass | | | | |
| zusammengestellt von: <i>compiled by:</i> | | genehmigt von: <i>authorized by:</i> | | | |
| Datum: <i>Date:</i> | 2022-03-25 | Ausstellungsdatum: <i>Issue date:</i> | 2022-03-25 | | |
| Stellung / Position: | Senior Project Manager | Stellung / Position: | Senior Project Manager | | |
| Sonstiges / Other: | | | | | |
| Zustand des Prüfgegenstandes bei Anlieferung: <i>Condition of the test item at delivery:</i> | Prüfmuster vollständig und unbeschädigt <i>Test item complete and undamaged</i> | | | | |
| * Legende: | 1 = sehr gut P(ass) = entspricht o.g. Prüfgrundlage(n) | 2 = gut F(ail) = entspricht nicht o.g. Prüfgrundlage(n) | 3 = befriedigend F(ail) = entspricht nicht o.g. Prüfgrundlage(n) | 4 = ausreichend N/A = nicht anwendbar | 5 = mangelhaft N/T = nicht getestet |
| * Legend: | 1 = very good P(ass) = passed a.m. test specification(s) | 2 = good F(ail) = failed a.m. test specification(s) | 3 = satisfactory F(ail) = failed a.m. test specification(s) | 4 = sufficient N/A = not applicable | 5 = poor N/T = not tested |
| <p>Dieser Prüfbericht bezieht sich nur auf das o.g. Prüfmuster und darf ohne Genehmigung der Prüfstelle nicht auszugsweise vervielfältigt werden. Dieser Bericht berechtigt nicht zur Verwendung eines Prüfzeichens. <i>This test report only relates to the a. m. test sample. Without permission of the test center this test report is not permitted to be duplicated in extracts. This test report does not entitle to carry any test mark.</i></p> | | | | | |

TEST SUMMARY

| Report Section | FCC Clause | Test Item | Result |
|----------------|-----------------------------|---|--------|
| 5.1.1 | 15.247(b) & 15.203 | Antenna Requirement | Pass |
| 5.1.2 | 15.247(b)(3) | Peak Output Power | Pass |
| 5.1.3 | 15.247(a)(2) | 6 dB Bandwidth | Pass |
| 5.1.3 | 2.1049 | 99% Occupied Bandwidth | Pass |
| 5.1.4 | 15.247(e) | Power Spectral Density | Pass |
| 5.1.5 | 15.247(d) | Conducted Spurious Emissions and Band Edges | Pass |
| 5.1.6 | 15.247(d) & 15.205 & 15.209 | Radiated Spurious Emissions and Band Edges | Pass |
| 5.2.1 | 15.207 | Mains Conducted Emission | Pass |

Note: Determining compliance based on the results of the compliance measurement, not taking into account measurement instrumentation uncertainty.

Contents

| | |
|--|-----------|
| HISTORY OF THIS TEST REPORT | 5 |
| 1. GENERAL REMARKS | 6 |
| 1.1 COMPLEMENTARY MATERIALS..... | 6 |
| 1.2 DECISION RULE OF CONFORMITY | 6 |
| 2. TEST SITES | 7 |
| 2.1 TEST LABORATORY | 7 |
| 2.2 TEST FACILITY..... | 7 |
| 2.3 TRACEABILITY | 8 |
| 2.4 CALIBRATION | 8 |
| 2.5 MEASUREMENT UNCERTAINTY | 8 |
| 3. GENERAL PRODUCT INFORMATION..... | 9 |
| 3.1 PRODUCT FUNCTION AND INTENDED USE | 9 |
| 3.2 SYSTEM DETAILS AND RATINGS..... | 9 |
| 3.3 NOISE GENERATING AND NOISE SUPPRESSING PARTS | 10 |
| 3.4 SUBMITTED DOCUMENTS..... | 10 |
| 4. TEST SET-UP AND OPERATION MODES..... | 11 |
| 4.1 PRINCIPLE OF CONFIGURATION SELECTION | 11 |
| 4.2 CARRIER FREQUENCY AND CHANNEL..... | 11 |
| 4.3 TEST OPERATION AND TEST SOFTWARE..... | 12 |
| 4.4 SPECIAL ACCESSORIES AND AUXILIARY EQUIPMENT | 13 |
| 4.5 TEST SETUP DIAGRAM | 14 |
| 5. TEST RESULTS | 15 |
| 5.1 TRANSMITTER REQUIREMENT & TEST SUITES | 15 |
| 5.1.1 <i>Antenna Requirement</i> | <i>15</i> |
| 5.1.2 <i>Peak Output Power</i> | <i>16</i> |
| 5.1.3 <i>6 dB Bandwidth and 99% Occupied Bandwidth.....</i> | <i>18</i> |
| 5.1.4 <i>Power Spectral Density.....</i> | <i>19</i> |
| 5.1.5 <i>Conducted Spurious Emissions and Frequency Band Edges Measured in 100kHz Bandwidth.....</i> | <i>20</i> |
| 5.1.6 <i>Radiated Spurious Emissions and Band Edges</i> | <i>21</i> |
| 5.2 MAINS EMISSION | 26 |
| 5.2.1 <i>Mains Conducted Emission.....</i> | <i>26</i> |

Prüfbericht - Nr.: CN22C1SP(P15C-BLE) 001
Test Report No.

Seite 4 von 27
Page 4 of 27

APPENDIX A - TEST RESULT OF CONDUCTED

APPENDIX B - TEST RESULT OF RADIATED EMISSIONS & MAINS CONDUCTED EMISSION

APPENDIX SP - PHOTOGRAPHS OF TEST SETUP

APPENDIX EP - PHOTOGRAPHS OF EUT

Prüfbericht - Nr.: CN22C1SP(P15C-BLE) 001
Test Report No.

Seite 5 von 27
Page 5 of 27

HISTORY OF THIS TEST REPORT

| Report No. | Description | Date Issued |
|------------------------|------------------|-------------|
| CN22C1SP(P15C-BLE) 001 | Original Release | 2022-03-25 |

1. General Remarks

1.1 Complementary Materials

All attachments are integral parts of this test report. This applies especially to the following appendix:

Appendix A - Test Result of Conducted

Appendix B - Test Result of Radiated Emissions & Mains Conducted Emission

Appendix SP - Photographs of Test Setup

Appendix EP - Photographs of EUT

Applied Standard and Test Levels

| Radio |
|---|
| FCC 47CFR Part 15: Subpart C Section 15.247 |
| FCC 47CFR Part 2: Subpart J Section 2.1049 |
| ANSI C63.10:2013 |
| KDB 558074 D01 15.247 Meas Guidance v05r02 |

1.2 Decision Rule of Conformity

The decision rule of conformity of this test report is following the requirements of the requested standard in the quotation, and agreed among testing laboratory and manufacturer (applicant) to exclude the consideration of Measurement Uncertainty, unless it is required by the specific standard.

2. Test Sites

2.1 Test Laboratory

Taipei Testing Laboratories

11F. No.758, Sec. 4, Bade Rd., Songshan Dist.
Taipei City 105
Taiwan (R.O.C.)

2.2 Test Facility

Taipei Testing Laboratories

No.458-18, Sec. 2, Fenliao Rd., Linkou Dist.,
New Taipei City 244
Taiwan (R.O.C.)
FCC Registration No.: 226631
ISED Registration No.: 25563

2.3 Traceability

All measurement equipment calibrations are traceable to NML(Taiwan)/NIST(USA) or where calibration is performed outside Taiwan, to equivalent nationally recognized standards organizations.

2.4 Calibration

Equipment requiring calibration is calibrated periodically in a suitably accredited Calibration Lab. Additionally all equipment is verified for proper performance on a regular basis using in house standards or comparisons.

2.5 Measurement Uncertainty

All measurement uncertainty values are shown with a coverage factor of $k=2$ to indicate a 95% level of confidence.

Emission Measurement Uncertainty

| Parameter | Uncertainty |
|--------------------------------------|---------------|
| Radiated Emission (9 kHz ~ 30 MHz) | ± 1.15 dB |
| Radiated Emission (30 MHz ~ 200 MHz) | ± 1.30 dB |
| Radiated Emission (200 MHz ~ 1 GHz) | ± 1.30 dB |
| Radiated Emission (1 GHz ~ 18 GHz) | ± 1.54 dB |
| Radiated Emission (18 GHz ~ 40 GHz) | ± 2.52 dB |
| Mains Conducted Emission | ± 1.65 dB |

3. General Product Information

3.1 Product Function and Intended Use

The EUT is a Bluetooth v5.0 BLE Single Mode Module. It contains a Bluetooth compatible module enabling the user to communicate data through a Wireless interface.

For details refer to the User Guide, Data Sheet and Circuit Diagram.

3.2 System Details and Ratings

Basic Information of EUT

| Item | EUT information |
|-----------------------------|---------------------------------------|
| Kind of Equipment/Test Item | Bluetooth v5.0 BLE Single Mode Module |
| Type Identification | BL5032 |
| FCC ID | YX6BL5032 |

Technical Specification of EUT

| Item | EUT information |
|---------------------------|---------------------|
| Operating Frequency | 2402 MHz ~ 2480 MHz |
| Channel Spacing | 2 MHz |
| Channel Number | 40 |
| Data Rate | 1Mbps, 2Mbps |
| Operation Voltage | 3.3Vdc |
| Modulation | GFSK |
| Maximum Output Power (mW) | 2.19 |
| Antenna Information | Refer to 5.1.1 |
| Accessory Device | Refer to 4.4 |

3.3 Noise Generating and Noise Suppressing Parts

Refer to the Circuit Diagram.

3.4 Submitted Documents

- Circuit Diagram
- Instruction Manual
- Rating Label
- Technical Description

4. Test Set-up and Operation Modes

4.1 Principle of Configuration Selection

The test modes were adapted accordingly in reference to the instructions for use.

During testing, Channel and Power Controlling Software provided by the customer was used to control the operating channel as well as the output power level. The RF output power selection is for the setting of RF output expected by the customer and is going to be fixed on the firmware of the final end product.

Table for Parameters of Test Software Setting

| Frequency (MHz) | Power Setting |
|-----------------|---------------|
| 2402 | 4 |
| 2440 | 4 |
| 2480 | 4 |

4.2 Carrier Frequency and Channel

| Channel | Freq. (MHz) | Channel | Freq. (MHz) | Channel | Freq. (MHz) | Channel | Freq. (MHz) |
|---------|-------------|---------|-------------|---------|-------------|---------|-------------|
| 0 | 2402 | 10 | 2422 | 20 | 2442 | 30 | 2462 |
| 1 | 2404 | 11 | 2424 | 21 | 2444 | 31 | 2464 |
| 2 | 2406 | 12 | 2426 | 22 | 2446 | 32 | 2466 |
| 3 | 2408 | 13 | 2428 | 23 | 2448 | 33 | 2468 |
| 4 | 2410 | 14 | 2430 | 24 | 2450 | 34 | 2470 |
| 5 | 2412 | 15 | 2432 | 25 | 2452 | 35 | 2472 |
| 6 | 2414 | 16 | 2434 | 26 | 2454 | 36 | 2474 |
| 7 | 2416 | 17 | 2436 | 27 | 2456 | 37 | 2476 |
| 8 | 2418 | 18 | 2438 | 28 | 2458 | 38 | 2478 |
| 9 | 2420 | 19 | 2440 | 29 | 2460 | 39 | 2480 |

4.3 Test Operation and Test Software

Setup for testing: Test samples are provided with a USB interface which makes it possible to control them through a test software installed on a notebook computer.
 This software was running on the laptop computer connected to the EUT. It was used to enable the operation modes listed as below.

| | |
|---------------|-----------|
| Test Software | PuTTY.exe |
|---------------|-----------|

The samples were used as follows:
 A003213909-001 for conducted test
 A003213909-003 for radiated test
 Full test was applied on all test modes, but only worst case was shown.

| EUT Configure Mode | Applicable To | | | Mains Conducted Emission | Description |
|--------------------|------------------------------------|---|---|--------------------------|-------------|
| | Antenna Port Conducted Measurement | Radiated Spurious Emissions above 1 GHz | Radiated Spurious Emissions below 1 GHz | | |
| - | √ | √ | √ | √ | - |

Note:

1. The EUT had been pre-tested on the positioned of each 3 axis. The worst case was found when position on **Z-plane**.
2. "-" means no effect.

Antenna Port Conducted Measurement

- Pre-Scan full test was applied on all test modes, but only worst case was shown.
- Following channel(s) was (were) selected for the final test as listed below.

| EUT Configure Mode | Available Frequency (MHz) | Tested Frequency (MHz) | Date Rate (Mbps) |
|--------------------|---------------------------|------------------------|------------------|
| - | 2402 to 2480 | 2402, 2440, 2480 | 1 |
| - | 2402 to 2480 | 2402, 2440, 2480 | 2 |

Radiated Spurious Emissions (Above 1 GHz)

- Pre-Scan full test was applied on all test modes, but only worst case was shown.
- Following channel(s) was (were) selected for the final test as listed below.

| EUT Configure Mode | Available Frequency (MHz) | Tested Frequency (MHz) | Date Rate (Mbps) |
|--------------------|---------------------------|------------------------|------------------|
| - | 2402 to 2480 | 2402, 2440, 2480 | 1 |
| - | 2402 to 2480 | 2402, 2440, 2480 | 2 |

Radiated Spurious Emissions (Below 1 GHz)

- Pre-Scan full test was applied on all test modes, but only worst case was shown.
- Following channel(s) was (were) selected for the final test as listed below.

| EUT Configure Mode | Available Frequency (MHz) | Tested Frequency (MHz) | Date Rate (Mbps) |
|--------------------|---------------------------|------------------------|------------------|
| - | 2402 to 2480 | 2402 | 1 |

Mains Conducted Emission

- Pre-Scan full test was applied on all test modes, but only worst case was shown.
- Following channel(s) was (were) selected for the final test as listed below.

| EUT Configure Mode | Available Frequency (MHz) | Tested Frequency (MHz) | Date Rate (Mbps) |
|--------------------|---------------------------|------------------------|------------------|
| - | 2402 to 2480 | 2402 | 1 |

Test Condition

| Test Item | Ambient Temperature | Relative Humidity | Tested by |
|---|---------------------|-------------------|-------------------|
| Conducted Measurement | 22.7 °C | 64 % | Stanislas Charles |
| Radiated Spurious Emissions above 1 GHz | 23.8-24.5 °C | 57-62 % | Hunter Wang |
| Radiated Spurious Emissions below 1 GHz | 23.8-24.5 °C | 57-62 % | Hunter Wang |
| Mains Conducted Emission | 21.5 °C | 54 % | Hunter Wang |

4.4 Special Accessories and Auxiliary Equipment

The product has been tested together with the following additional accessories:

Accessory of EUT

None.

Support Unit

| No. | Description | Brand | Model | S/N | Remark |
|-----------------------------|--------------------|------------|---------------|------------|-------------------------------------|
| Radiated Test | | | | | |
| A | DC Cable | Atech OEM | Atech OEM_001 | - | - |
| B | Fixture | BT Fixture | 94V-B | - | - |
| 1 | RS232 to USB Cable | TUV | TUV-002 | - | 161 cm shielded cable with core |
| 2 | DC Cable | TUV | TUV-004 | - | 165 cm non-shielded cable w/o core |
| 3 | Power Supply | Gwinstek | GPC-3030DQ | GEU915613 | 180 cm non-shielded cable w/o core |
| 4 | Notebook | Lenovo | 81BL | MP1DCD6Y | - |
| Mains Conducted Test | | | | | |
| A | DC Cable | Atech OEM | Atech OEM_001 | - | 6 cm non-shielded cable w/o core |
| B | Fixture | BT Fixture | 94V-B | - | - |
| 1 | Power Supply | Gwinstek | GPC-3030DQ | GEU915613 | 180 cm non-shielded cable with core |
| 2 | DC Cable | TUV | TUV-004 | - | 165 cm non-shielded cable w/o core |
| 3 | RS232 to USB Cable | TUV | TUV-002 | - | 161 cm shielded cable with core |
| 4 | Notebook | Lenovo | 81BL | MP1DCD6Y | - |
| Conducted Test | | | | | |
| - | Notebook | HP | TPN-C139 | CND93662VF | - |
| - | Power Supply | PeakTech | 2250 | 188 | - |

4.5 Test Setup Diagram

<Radiated Spurious Emissions mode>

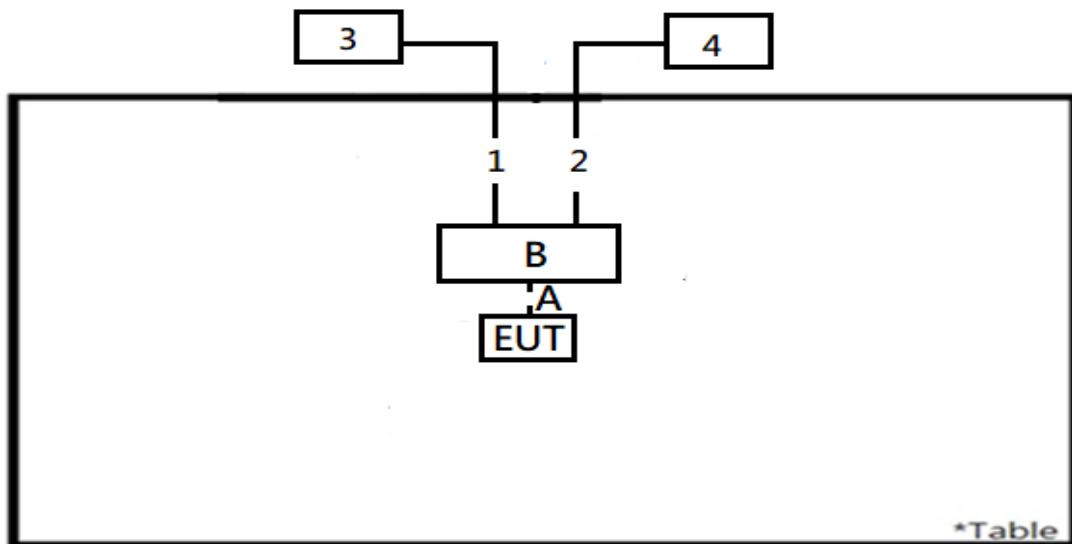

<Mains Conducted Emission mode>

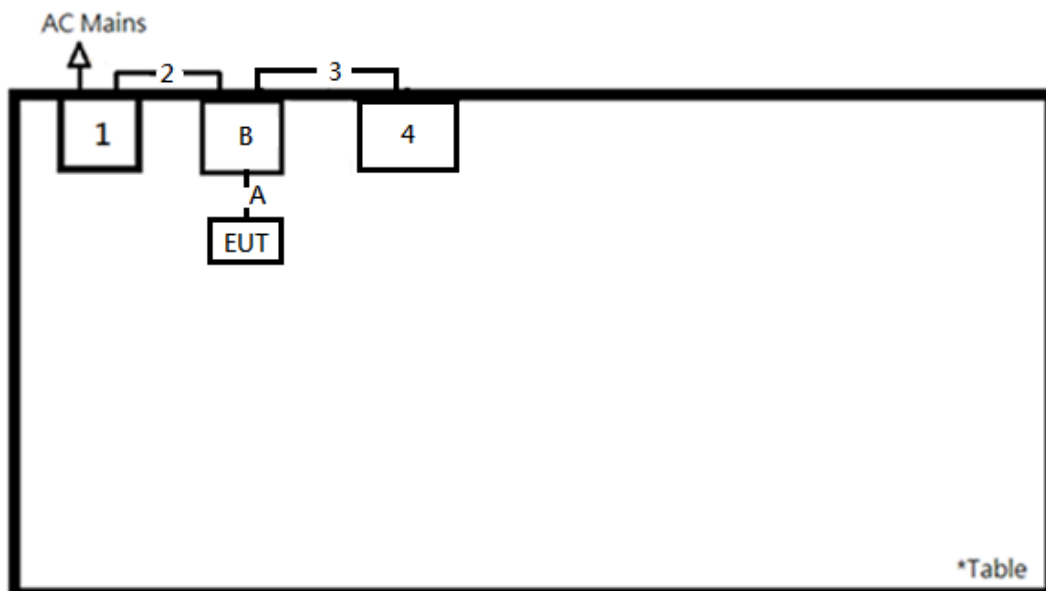

5. Test Results

5.1 Transmitter Requirement & Test Suites

5.1.1 Antenna Requirement

Requirement Use of approved antennas only

According to the manufacturer declaration, the EUT has an antenna with a directional gain of 3.75 dBi. The antenna is PCB antenna with no possibility of replacement with a non-approved antenna by the end-user. Therefore, the EUT is considered to comply with this provision. Refer to EUT photo for details.

5.1.2 Peak Output Power

Limit 1 watt (30 dBm)

Kind of Test Site Shielded room

Test Setup



Test Instruments

| Kind of Equipment | Manufacturer | Type | S/N | Calibration Date | Calibration Due Date | Test Date | |
|-------------------|--------------|---------|---------|------------------|----------------------|-----------|-----------|
| | | | | | | From | Until |
| Power Meter | Anritsu | ML2495A | 1901008 | 2022/3/14 | 2023/3/13 | 2022/3/16 | 2022/3/16 |
| Power Sensor | Anritsu | MA2411B | 1725269 | 2022/3/14 | 2023/3/13 | 2022/3/16 | 2022/3/16 |

Test Procedures

A peak power sensor was used on the output port of the EUT. A power meter was used to read the response of the peak power sensor. Record the power level.

Average power sensor was used to perform output power measurement, trigger and gating function of wide band power meter is enabled to measure max output power of TX on burst. Duty factor is not added to measured value.

Test Result
Peak Output Power
<1Mbps>

| Channel | Channel Frequency | Peak Output Power | | Limit (dBm) |
|----------------|-------------------|-------------------|------|-------------|
| | (MHz) | (dBm) | (mW) | |
| Low Channel | 2402 | 3.41 | 2.19 | 30 |
| Middle Channel | 2440 | 3.40 | 2.19 | 30 |
| High Channel | 2480 | 3.31 | 2.14 | 30 |

<2Mbps>

| Channel | Channel Frequency | Peak Output Power | | Limit (dBm) |
|----------------|-------------------|-------------------|------|-------------|
| | (MHz) | (dBm) | (mW) | |
| Low Channel | 2402 | 3.40 | 2.19 | 30 |
| Middle Channel | 2440 | 3.39 | 2.18 | 30 |
| High Channel | 2480 | 3.31 | 2.14 | 30 |

Average Power
<1Mbps>

| Channel | Channel Frequency | Average Power | |
|----------------|-------------------|---------------|------|
| | (MHz) | (dBm) | (mW) |
| Low Channel | 2402 | 3.35 | 2.16 |
| Middle Channel | 2440 | 3.34 | 2.16 |
| High Channel | 2480 | 3.25 | 2.11 |

<2Mbps>

| Channel | Channel Frequency | Average Power | |
|----------------|-------------------|---------------|------|
| | (MHz) | (dBm) | (mW) |
| Low Channel | 2402 | 3.35 | 2.16 |
| Middle Channel | 2440 | 3.33 | 2.15 |
| High Channel | 2480 | 3.25 | 2.11 |

5.1.3 6 dB Bandwidth and 99% Occupied Bandwidth

Limit The minimum 6 dB bandwidth shall be at least 500 kHz.

Kind of Test Site Shielded room

Test Setup

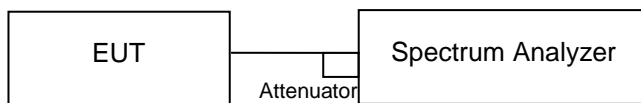

Test Instruments

| Kind of Equipment | Manufacturer | Type | S/N | Calibration Date | Calibration Due Date | Test Date | |
|-------------------|--------------|-------|--------|------------------|----------------------|-----------|-----------|
| | | | | | | From | Until |
| Spectrum Analyzer | R&S | FSV40 | 100921 | 2021/5/10 | 2022/5/9 | 2022/3/16 | 2022/3/16 |

Test Procedure

- a. Set resolution bandwidth (RBW) = 100 kHz
- b. Set the video bandwidth (VBW) $\geq 3 \times$ RBW, Detector = Peak.
- c. Trace mode = max hold.
- d. Sweep = auto couple.
- e. Measure the maximum width of the emission that is constrained by the frequencies associated with the two amplitude points (upper and lower) that are attenuated by 6 dB relative to the maximum level measured in the fundamental emission.
- f. For 99% occupied bandwidth measurement, the transmitter output was connected to the spectrum analyzer through an attenuator. The bandwidth of the fundamental frequency was measured by spectrum analyzer with resolution bandwidth in the range of 1% to 5% of the anticipated emission bandwidth, and a video bandwidth at least 3x the resolution bandwidth and set the detector to PEAK. The width of a frequency band such that, below the lower and above the upper frequency limits, the mean powers emitted are each equal to a specified percentage 0.5% of the total mean power of a given emission.

Test Results

Please refer to Appendix A.

5.1.4 Power Spectral Density

Limit

The power spectral density shall not be greater than 8 dBm in any 3 kHz band.

Kind of Test Site Shielded room

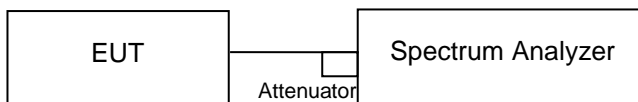
Test Setup

Test Instruments

| Kind of Equipment | Manufacturer | Type | S/N | Calibration Date | Calibration Due Date | Test Date | |
|-------------------|--------------|-------|--------|------------------|----------------------|-----------|-----------|
| | | | | | | From | Until |
| Spectrum Analyzer | R&S | FSV40 | 100921 | 2021/5/10 | 2022/5/9 | 2022/3/16 | 2022/3/16 |

Test Procedure

- a. Set analyzer center frequency to DTS channel center frequency.
- b. Set the span to 1.5 times the DTS bandwidth.
- c. Set the RBW to: $3 \text{ kHz} \leq \text{RBW} \leq 100 \text{ kHz}$.
- d. Set the VBW $\geq 3 \times \text{RBW}$.
- e. Detector = peak.
- f. Sweep time = auto couple.
- g. Trace mode = max hold.
- h. Allow trace to fully stabilize.
- i. Use the peak marker function to determine the maximum amplitude level within the RBW.

Test Results

Please refer to Appendix A.

5.1.5 Conducted Spurious Emissions and Frequency Band Edges Measured in 100kHz Bandwidth

Limit

20dB (below that in the 100 kHz bandwidth within the band that contains the highest level of the desired power.)

Kind of Test Site Shielded room

Test Setup

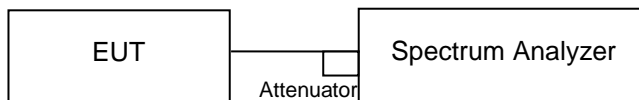

Test Instruments

| Kind of Equipment | Manufacturer | Type | S/N | Calibration Date | Calibration Due Date | Test Date | |
|-------------------|--------------|-------|--------|------------------|----------------------|-----------|-----------|
| | | | | | | From | Until |
| Spectrum Analyzer | R&S | FSV40 | 100921 | 2021/5/10 | 2022/5/9 | 2022/3/16 | 2022/3/16 |

Test Procedure

Measurement procedure REF

1. Set the RBW = 100 kHz.
2. Set the VBW \geq 300 kHz.
3. Detector = peak.
4. Sweep time = auto couple.
5. Trace mode = max hold.
6. Allow trace to fully stabilize.
7. Use the peak marker function to determine the maximum power level in any 100 kHz band segment within the fundamental EBW.

Measurement procedure OOBE

1. Set RBW = 100 kHz.
2. Set VBW \geq 300 kHz.
3. Detector = peak.
4. Sweep = auto couple.
5. Trace Mode = max hold.
6. Allow trace to fully stabilize.
7. Use the peak marker function to determine the maximum amplitude level.

Test Results

Please refer to Appendix A.

5.1.6 Radiated Spurious Emissions and Band Edges

Limit

Radiated emissions which fall in the restricted bands, as defined in §15.205(a), must comply with the radiated emission limits specified in §15.209(a).

Emissions radiated outside the restricted and authorized frequency bands must either comply with the radiated emission limits specified for the restricted bands or in §15.247(d).

Kind of Test Site 3m Semi-Anechoic Chamber

Test Setup

<Radiated Emissions below 30 MHz>

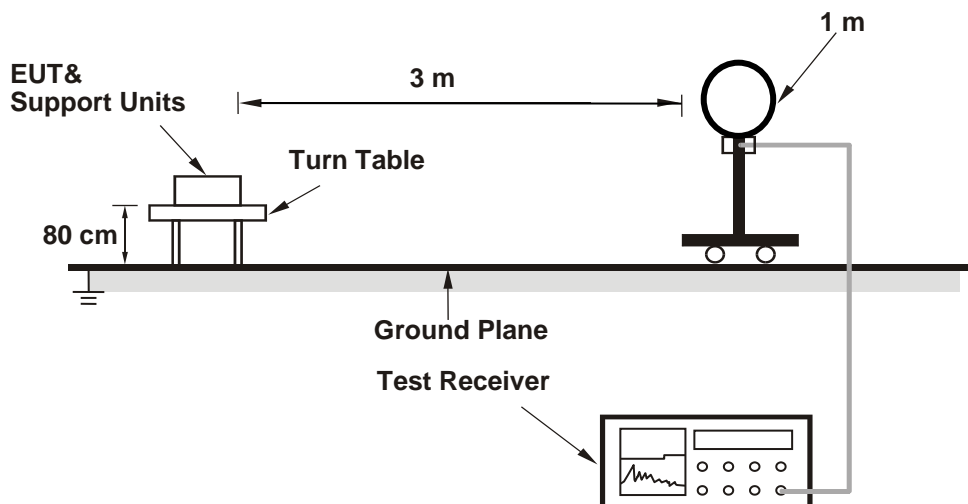

<Radiated Emissions 30 MHz to 1 GHz>

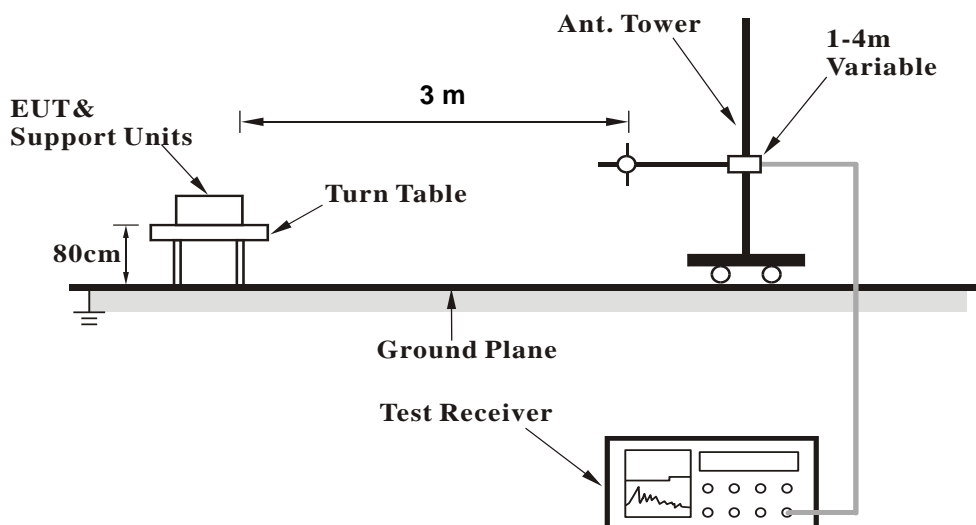

<Radiated Emissions above 1 GHz>

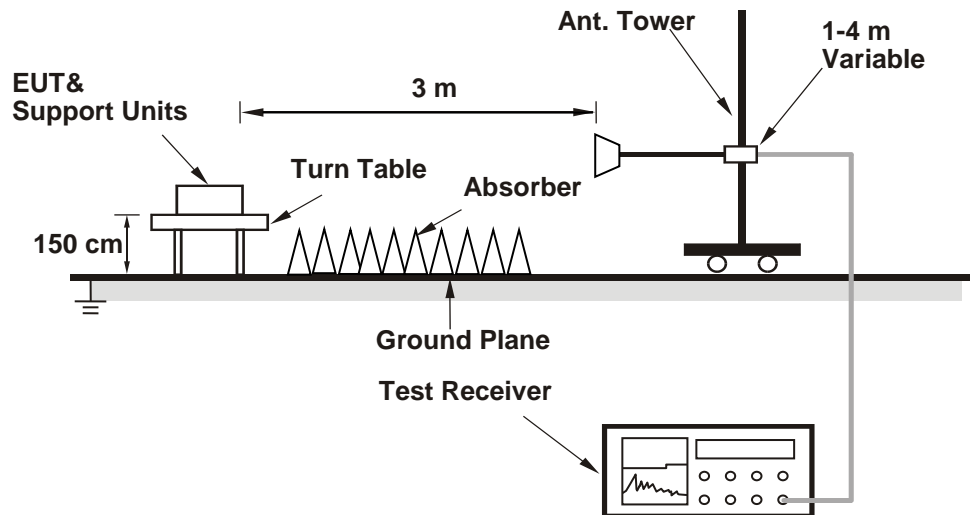

For the actual test configuration, please refer to the attached file (Test Setup Photo).

Test Instruments

Test period: 2022/3/21 ~ 2022/3/22

| Kind of Equipment | Manufacturer | Type | S/N | Calibration Date | Calibration Due Date |
|--------------------|--------------|----------------|------------|------------------|----------------------|
| Receiver | R&S | ESR7 | 102109 | 2022/3/16 | 2023/3/15 |
| Signal Analyzer | R&S | FSV40 | 101513 | 2021/3/28 | 2022/3/27 |
| Bilog Antenna | SCHWARZBECK | VULB-9168 | 00950 | 2022/3/6 | 2023/3/5 |
| Horn Antenna | ETS-Lindgren | 3117 | 00218930 | 2021/12/20 | 2022/12/19 |
| Horn Antenna | SCHWARZBECK | BBHA 9170 | 00887 | 2021/4/8 | 2022/4/7 |
| LF-AMP | Agilent | 8447D | 2727A05146 | 2022/2/16 | 2023/2/15 |
| HF-AMP + AC source | EMCI | EMC051845SE | 980633 | 2022/2/16 | 2023/2/15 |
| HF-AMP + AC source | EMCI | EMC184045SE | 980657 | 2022/2/16 | 2023/2/15 |
| Microwave Cable | HUBER+SUHNER | SUCOFLEX 104EA | 800056/4EA | 2021/3/25 | 2022/3/24 |
| Microwave Cable | HUBER+SUHNER | SUCOFLEX 104 | 804680/4 | 2021/3/25 | 2022/3/24 |
| Microwave Cable | HUBER+SUHNER | SUCOFLEX 104 | MY37202/4 | 2021/3/25 | 2022/3/24 |
| Microwave Cable | HUBER+SUHNER | SUCOFLEX 102EA | 800898/2EA | 2021/4/16 | 2022/4/15 |
| Microwave Cable | HUBER+SUHNER | SUCOFLEX 102EA | 800901/2EA | 2021/4/16 | 2022/4/15 |
| Microwave Cable | HUBER+SUHNER | SUCOFLEX 102EA | 801027/2EA | 2021/4/16 | 2022/4/15 |
| Loop Antenna | SCHWARZBECK | FMZB1519B | 00215 | 2021/12/8 | 2022/12/7 |

Test Procedures**For Radiated Emissions below 30 MHz**

- a. The EUT was placed on the top of a rotating table 0.8 meters above the ground at a 3 meter chamber room. The table was rotated 360 degrees to determine the position of the highest radiation.
- b. The EUT was set 3 meters away from the interference-receiving antenna, which was mounted on the top of a variable-height antenna tower.
- c. Parallel (OPEN), perpendicular (CLOSE), and ground-parallel (GROUND) orientations of the antenna are set to make the measurement.
- d. For each suspected emission, the EUT was arranged to its worst case and the rotatable table was turned from 0 degrees to 360 degrees to find the maximum reading.
- e. The test-receiver system was set to Quasi-Peak Detect Function and Specified Bandwidth with Maximum Hold Mode.

Note:

1. The resolution bandwidth and video bandwidth of test receiver/spectrum analyzer is 9 kHz at frequency below 30 MHz.
2. All modes of operation were investigated and the worst-case emissions are reported.

For Radiated Emissions above 30 MHz

- a. The EUT was placed on the top of a rotating table 0.8 meters (for 30 MHz ~ 1 GHz) / 1.5 meters (for above 1 GHz) above the ground at 3 meter chamber room for test. The table was rotated 360 degrees to determine the position of the highest radiation.
- b. The EUT was set 3 meters away from the interference-receiving antenna, which was mounted on the top of a variable-height antenna tower.
- c. The height of antenna is varied from one meter to four meters above the ground to determine the maximum value of the field strength. Both horizontal and vertical polarizations of the antenna are set to make the measurement.
- d. For each suspected emission, the EUT was arranged to its worst case and then the antenna was tuned to heights from 1 meter to 4 meters and the rotatable table was turned from 0 degrees to 360 degrees to find the maximum reading.
- e. The test-receiver system was set to quasi-peak detect function and specified bandwidth with maximum hold mode when the test frequency is below 1 GHz.
- f. The test-receiver system was set to peak and average detected function and specified bandwidth with maximum hold mode when the test frequency is above 1 GHz. If the peak reading value also meets average limit, measurement with the average detector is unnecessary.

Note:

1. The resolution bandwidth and video bandwidth of test receiver/spectrum analyzer is 120 kHz for Quasi-peak detection (QP) or Peak detection (PK) at frequency below 1 GHz.
2. The resolution bandwidth of test receiver/spectrum analyzer is 1 MHz and the video bandwidth is 3 MHz for Peak detection (PK) at frequency above 1 GHz.
3. The resolution bandwidth of test receiver/spectrum analyzer is 1 MHz and the video bandwidth is $\geq 1/T$ (Duty cycle < 98 %) or 10 Hz (Duty cycle ≥ 98 %) for Average detection (AV) at frequency above 1 GHz.
4. All modes of operation were investigated and the worst-case emissions are reported.
5. The Radiated Emissions testing was performed in the X(E1), Y(H) and Z(E2) axis orientation. The worst-case Axis orientation is recorded in this test report.

Prüfbericht - Nr.: CN22C1SP(P15C-BLE) 001
Test Report No.

Seite 25 von 27
Page 25 of 27

Test Results

Factor (dB/m) = Antenna Factor (dB/m) + Cable Loss (dB)
Level (dBuV/m) = Reading (dBuV) + Factor (dB/m)

Please refer to Appendix B.

5.2 Mains Emission

5.2.1 Mains Conducted Emission

Limit

Mains Conducted Emission as defined in §15.207 must comply with the mains conducted emission limits.

Kind of Test Site Shielded room

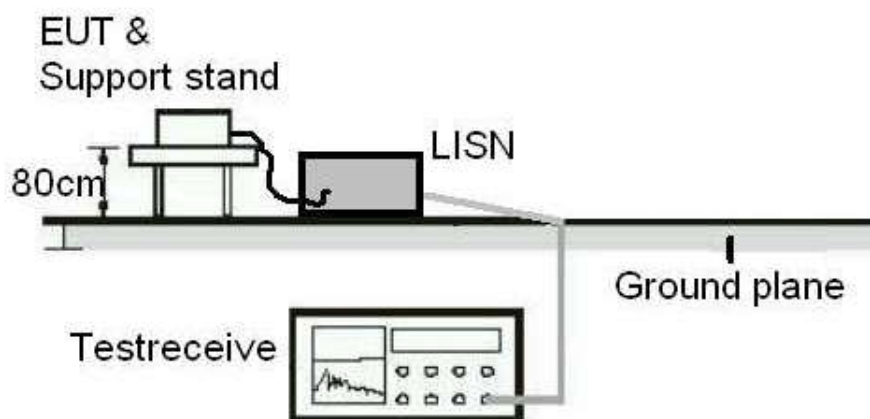
Test Setup

Test Instruments

| Kind of Equipment | Manufacturer | Type | S/N | Calibration Date | Calibration Due Date | Test Date | |
|--------------------|-----------------|--------|---------|------------------|----------------------|-----------|-----------|
| | | | | | | From | Until |
| RF Cable | N/A | N/A | EMC-003 | 2022/3/14 | 2023/3/13 | 2022/3/23 | 2022/3/23 |
| Two-Line V-Network | Rohde & Schwarz | ENV216 | 101938 | 2021/9/23 | 2022/9/22 | 2022/3/23 | 2022/3/23 |
| EMI Test Receiver | R&S | ESCI | 1816063 | 2021/11/15 | 2022/11/14 | 2022/3/23 | 2022/3/23 |

Test Procedures

- a. The EUT was placed 0.4 meters from the conducting wall of the shielded room with EUT being connected to the power mains through a line impedance stabilization network (LISN). Other support units were connected to the power mains through another LISN. The two LISNs provide 50 ohm/50 uH of coupling impedance for the measuring instrument.
- b. Both lines of the power mains connected to the EUT were checked for maximum conducted interference.
- c. The frequency range from 150 kHz to 30 MHz was searched. Emission levels under (Limit – 20 dB) was not recorded.

Note: The resolution bandwidth and video bandwidth of test receiver is 9 kHz for quasi-peak detection (QP) and average detection (AV) at frequency 0.15 MHz – 30 MHz.

Test Results

Please refer to Appendix B.

Appendix A: Test Results of Conducted Test

Test Result of 6 dB Bandwidth

BLE_1M

| Channel | Channel Frequency (MHz) | 6 dB Bandwidth (kHz) | Limit (kHz) | Result |
|----------------|-------------------------|----------------------|-------------|--------|
| Low Channel | 2402 | 500.50 | > 500 | Pass |
| Middle Channel | 2440 | 500.50 | > 500 | Pass |
| High Channel | 2480 | 500.50 | > 500 | Pass |

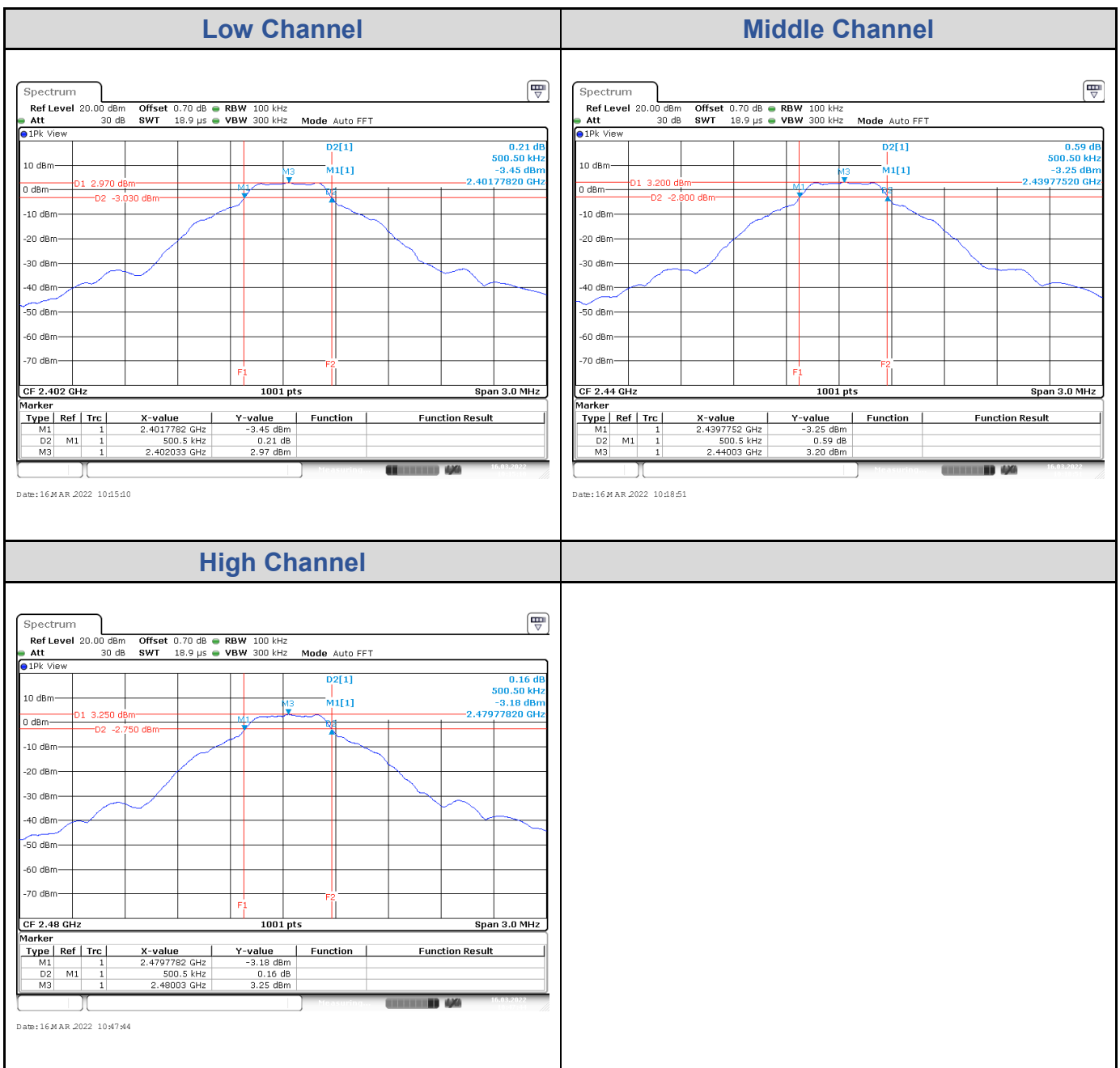

BLE_2M

| Channel | Channel Frequency (MHz) | 6 dB Bandwidth (kHz) | Limit (kHz) | Result |
|----------------|-------------------------|----------------------|-------------|--------|
| Low Channel | 2402 | 784.20 | > 500 | Pass |
| Middle Channel | 2440 | 864.10 | > 500 | Pass |
| High Channel | 2480 | 799.20 | > 500 | Pass |

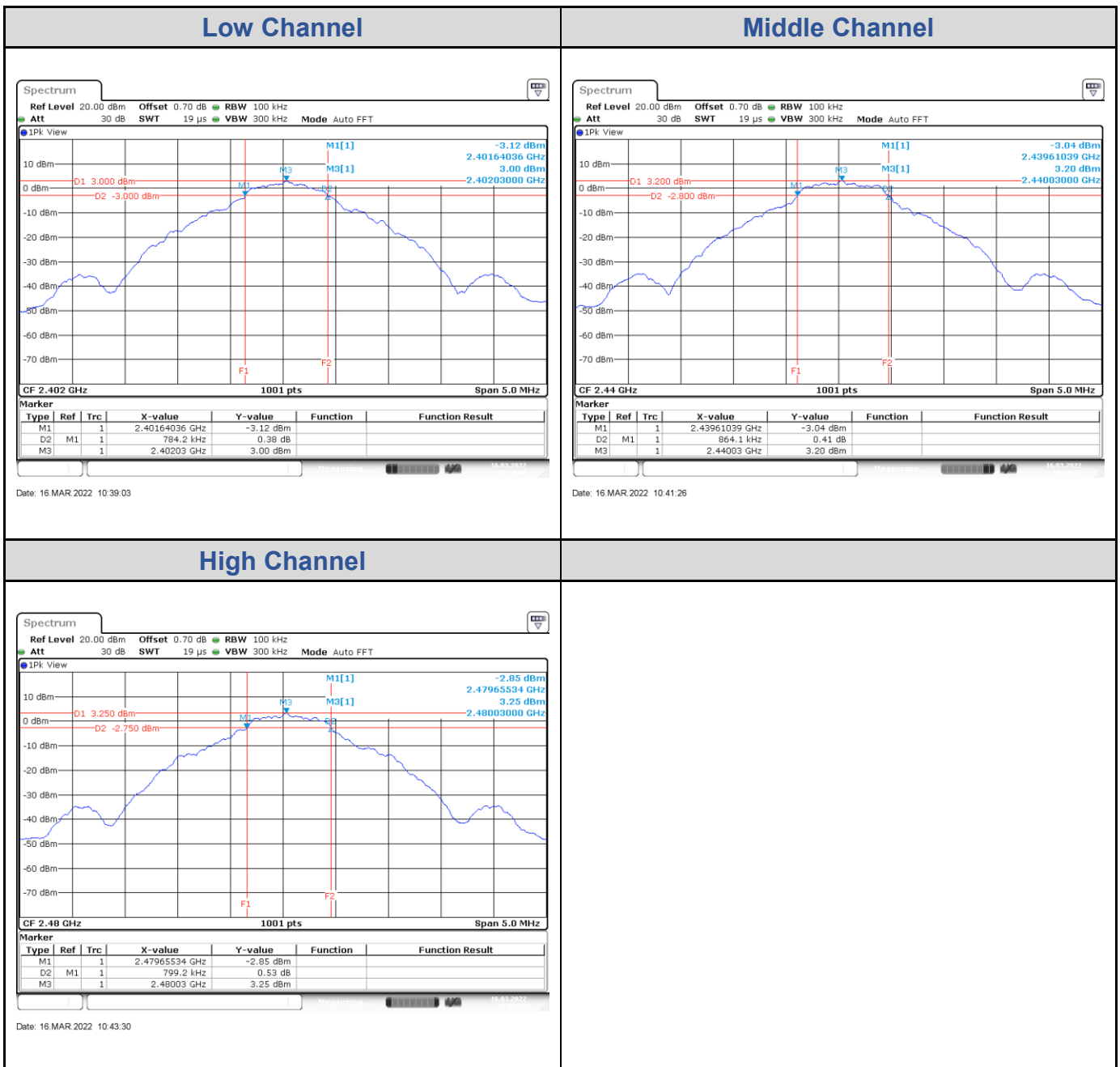

Test Result of 99% Occupied Bandwidth

BLE_1M

| Channel | Channel Frequency (MHz) | 99% Bandwidth (MHz) |
|----------------|-------------------------|---------------------|
| Low Channel | 2402 | 0.93 |
| Middle Channel | 2440 | 0.92 |
| High Channel | 2480 | 0.94 |

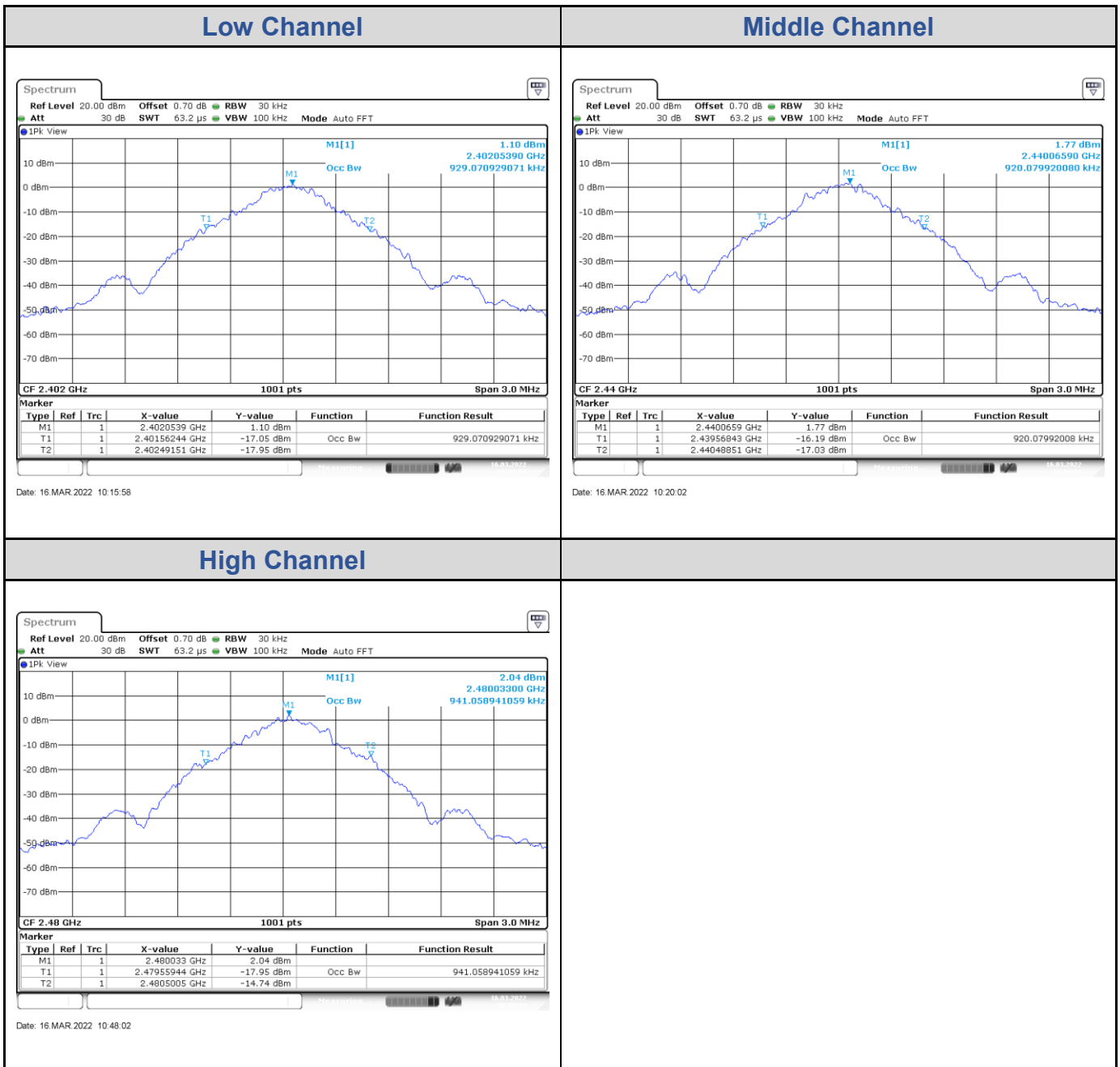

BLE_2M

| Channel | Channel Frequency (MHz) | 99% Bandwidth (MHz) |
|----------------|-------------------------|---------------------|
| Low Channel | 2402 | 1.84 |
| Middle Channel | 2440 | 1.76 |
| High Channel | 2480 | 1.80 |

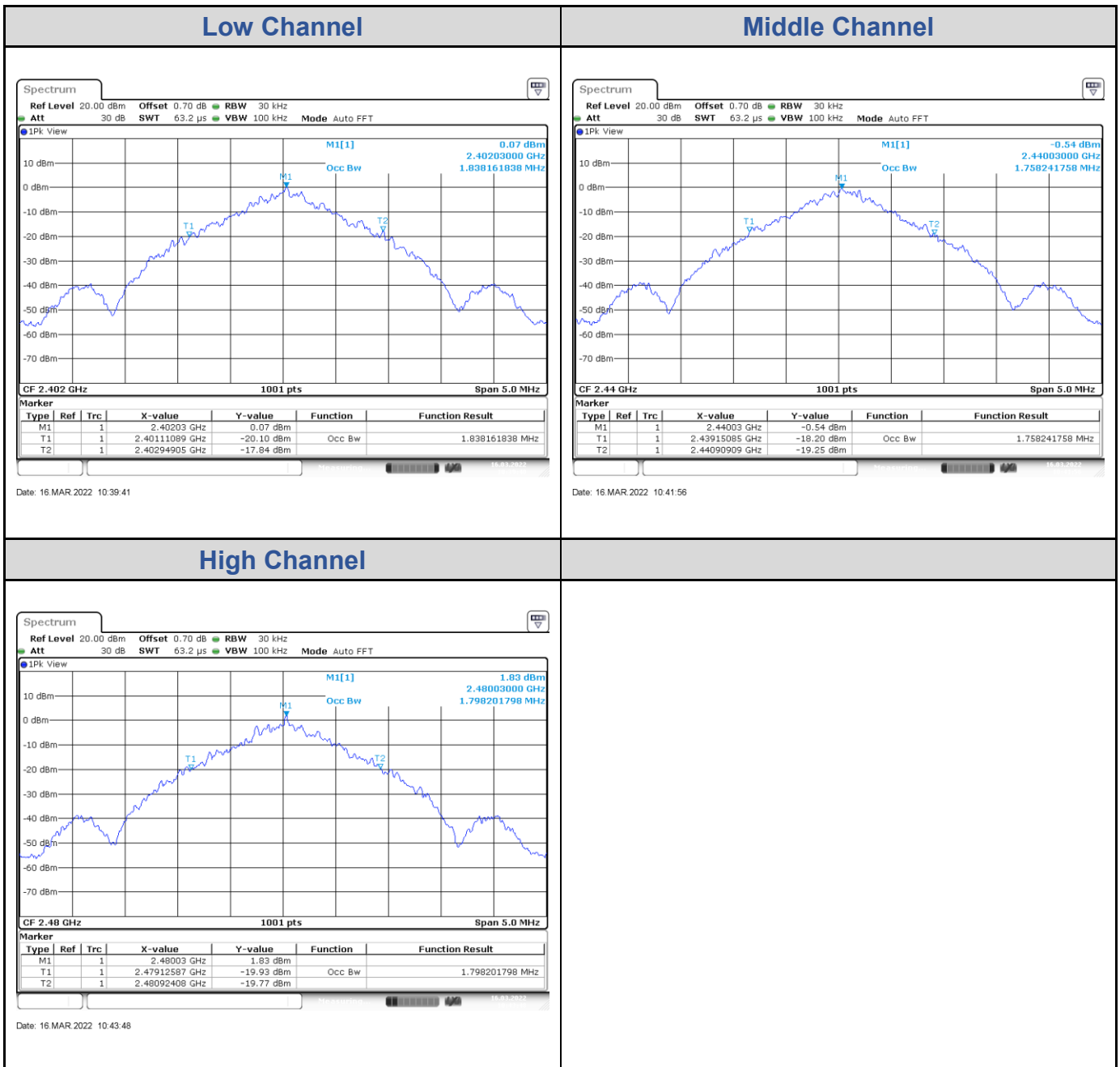

Test Result of Power Spectral Density

BLE_1M

| Channel | Channel Frequency (MHz) | Power Density (dBm/3kHz) | Limit (dBm/3kHz) | Result |
|----------------|-------------------------|--------------------------|------------------|--------|
| Low Channel | 2402 | -7.78 | 8 | Pass |
| Middle Channel | 2440 | -7.34 | 8 | Pass |
| High Channel | 2480 | -6.77 | 8 | Pass |

Low Channel

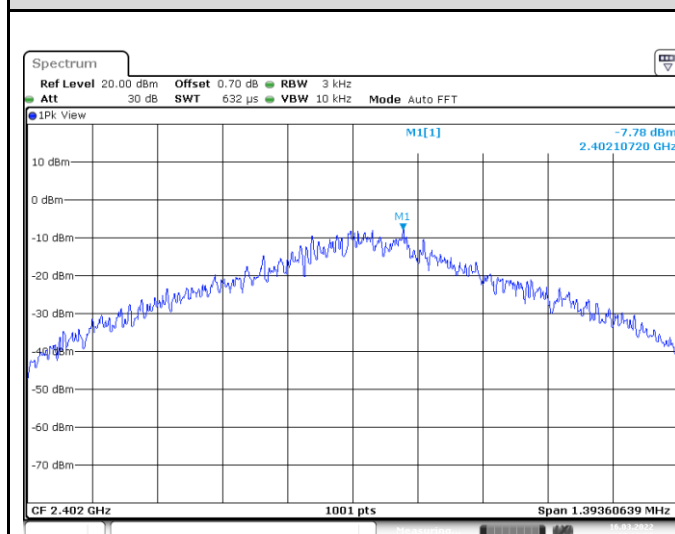

Middle Channel

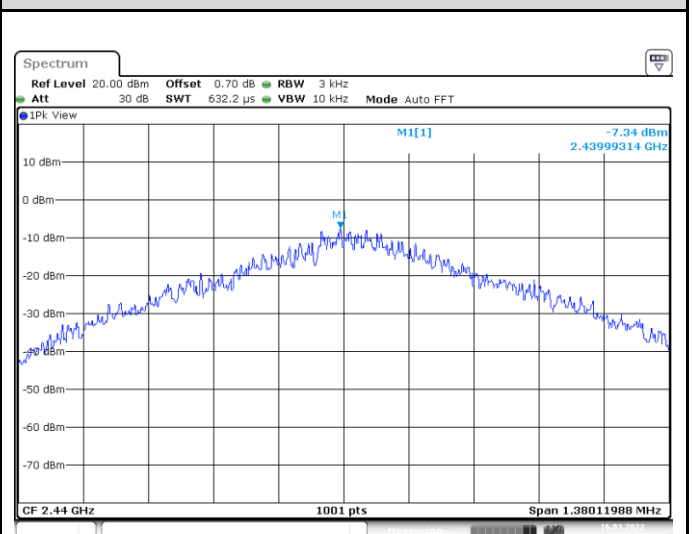

High Channel

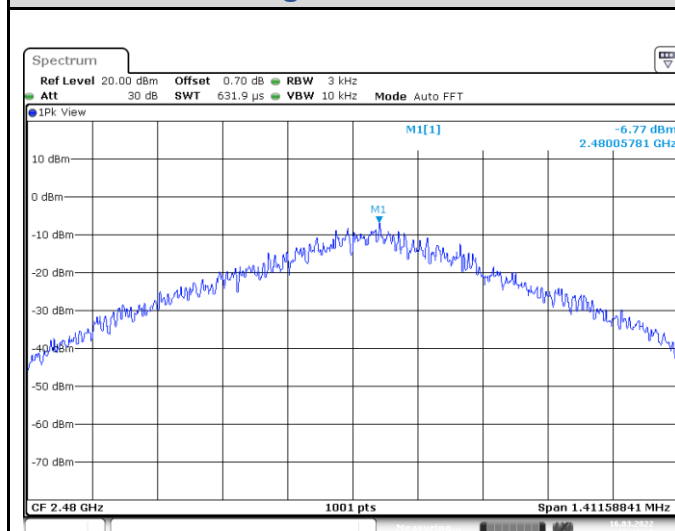

BLE_2M

| Channel | Channel Frequency (MHz) | Power Density (dBm/3kHz) | Limit (dBm/3kHz) | Result |
|----------------|-------------------------|--------------------------|------------------|--------|
| Low Channel | 2402 | -11.46 | 8 | Pass |
| Middle Channel | 2440 | -9.90 | 8 | Pass |
| High Channel | 2480 | -9.21 | 8 | Pass |

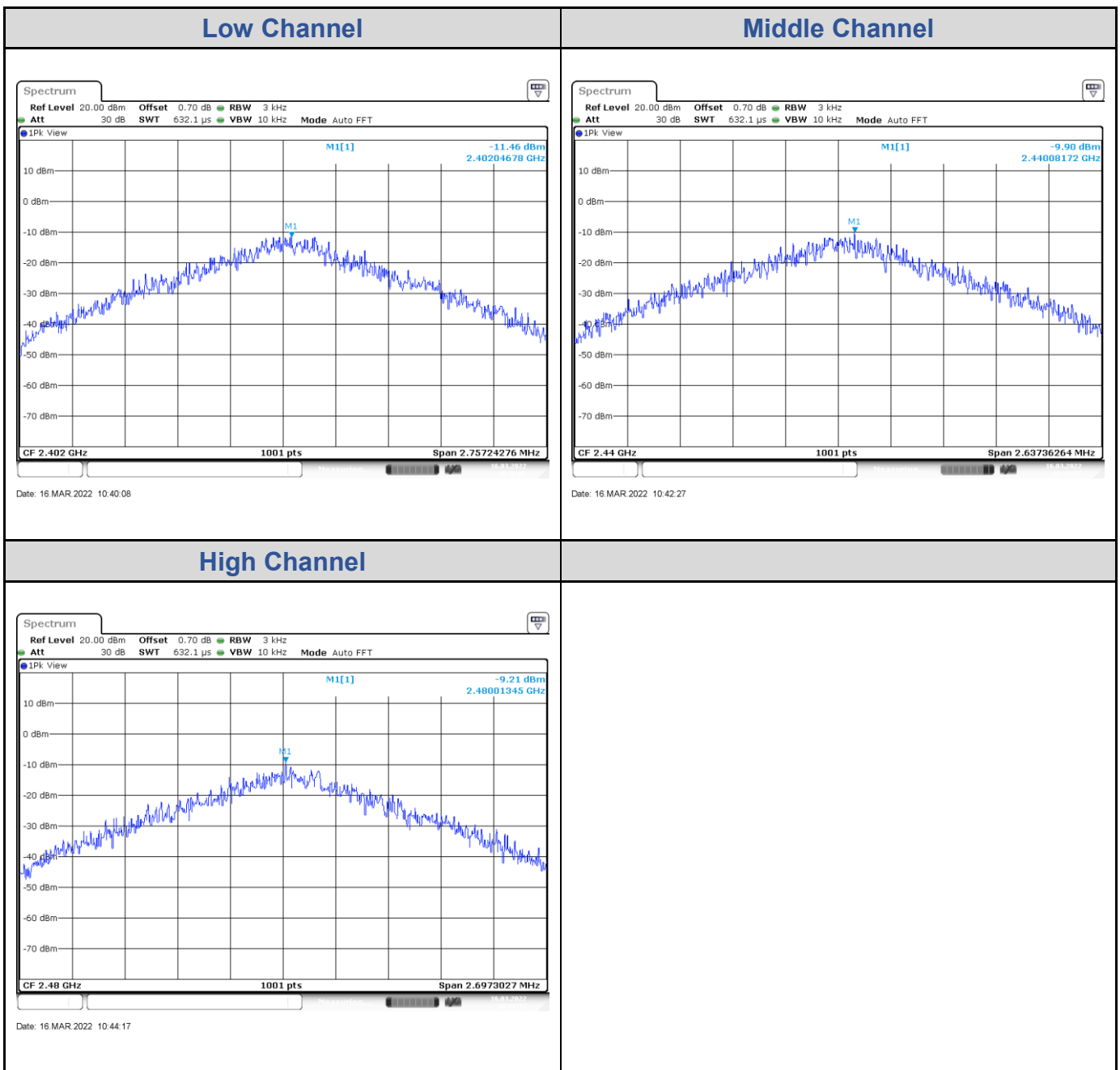

Test Result of Conducted Spurious Emissions, Tx Mode

BLE_1M

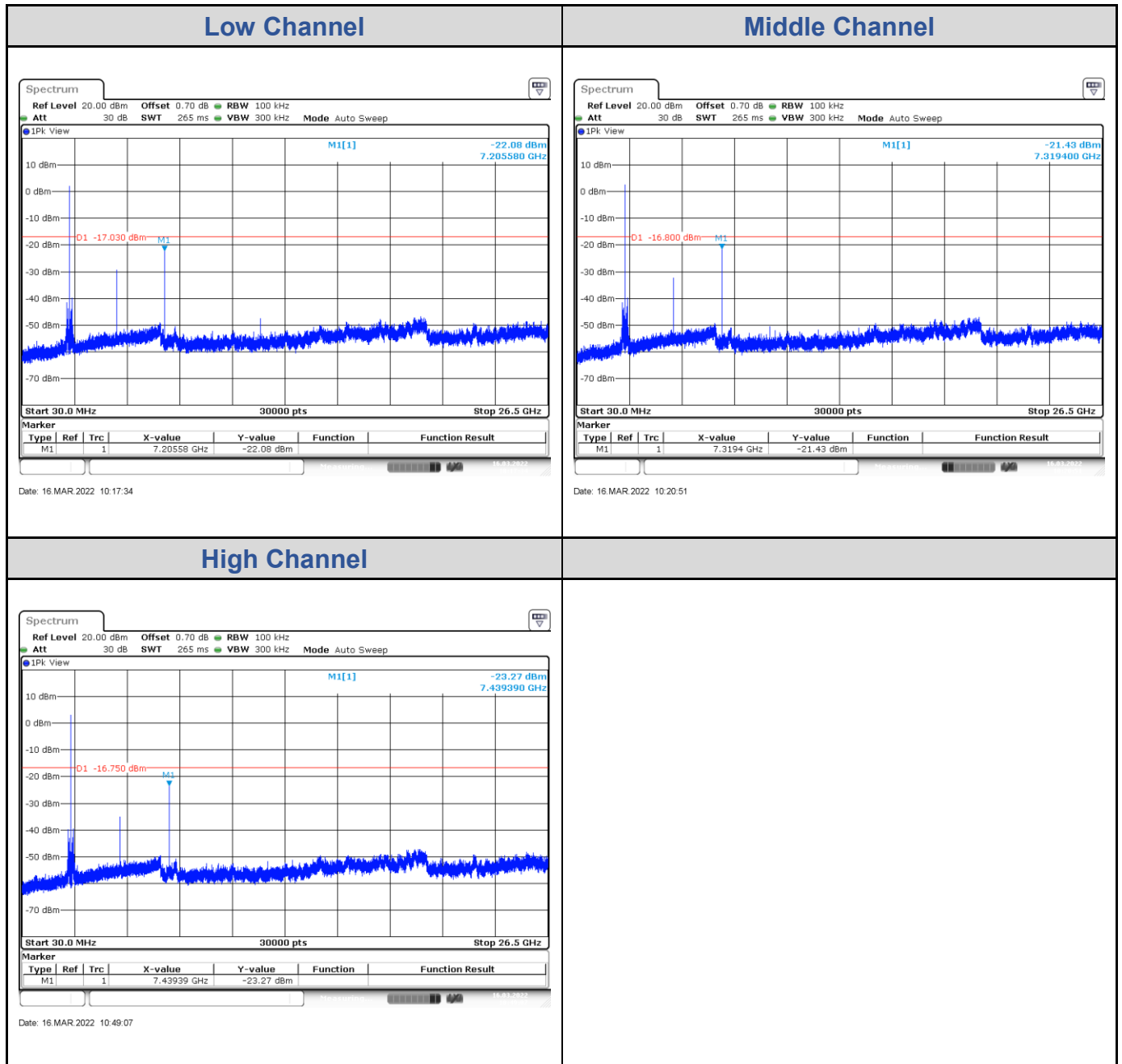

BLE_2M

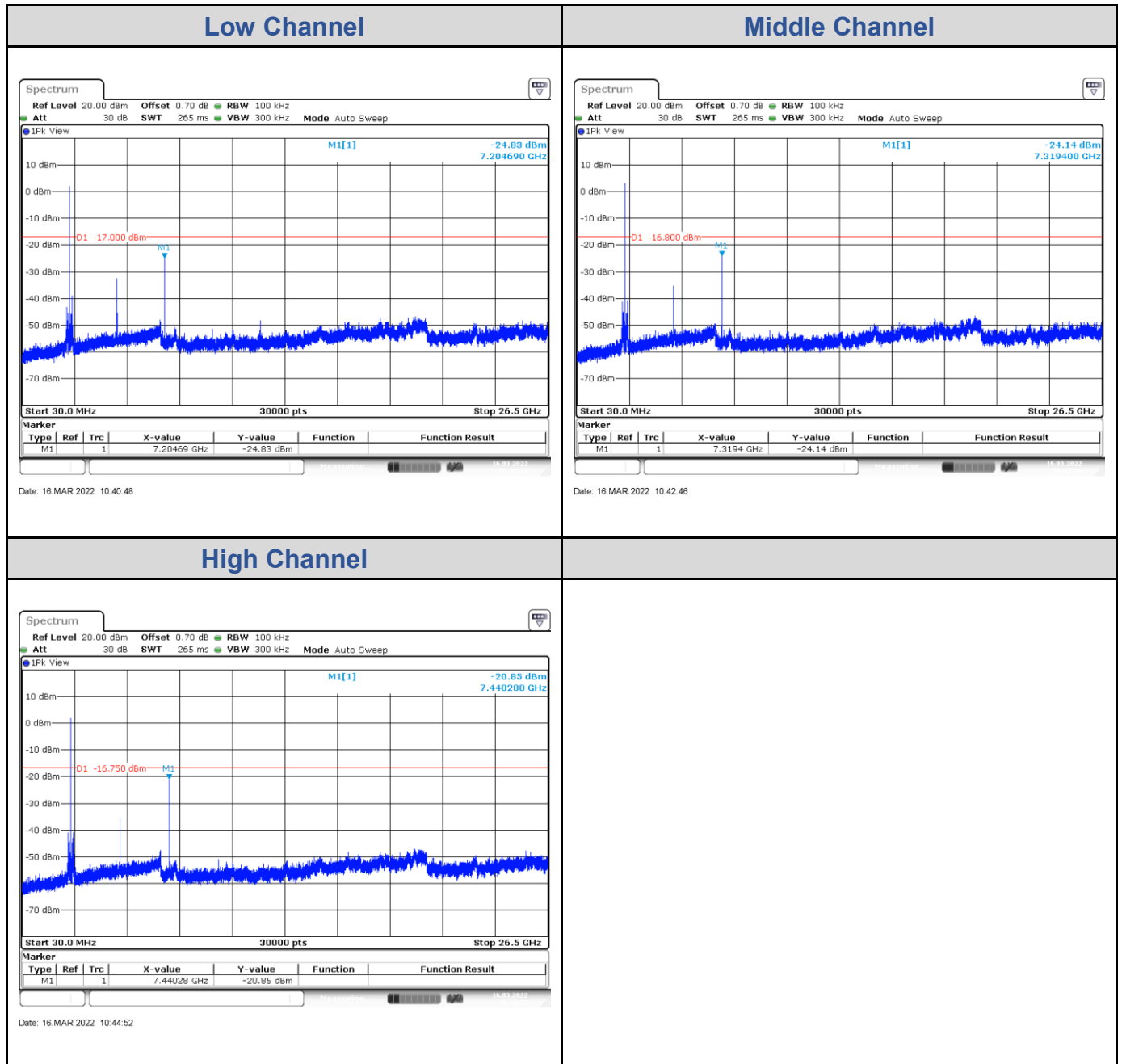

Test Result of Conducted Band Edge, Tx Mode

BLE_1M

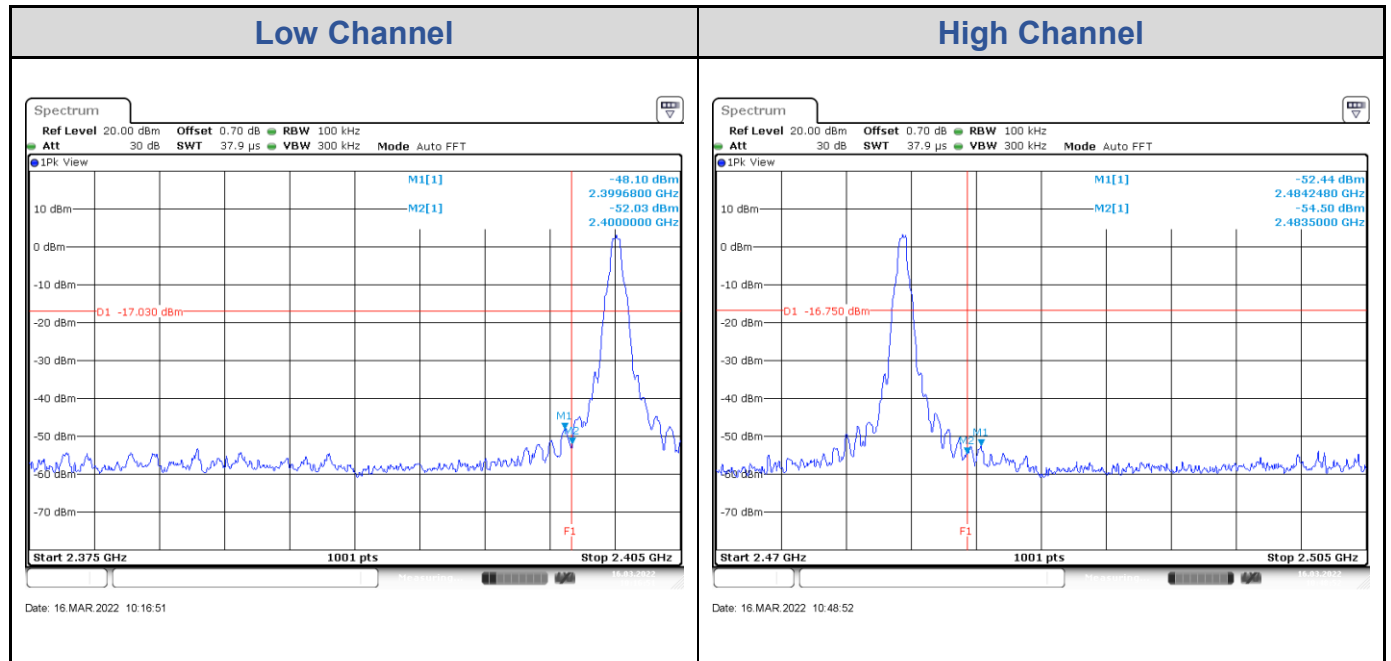

BLE_2M

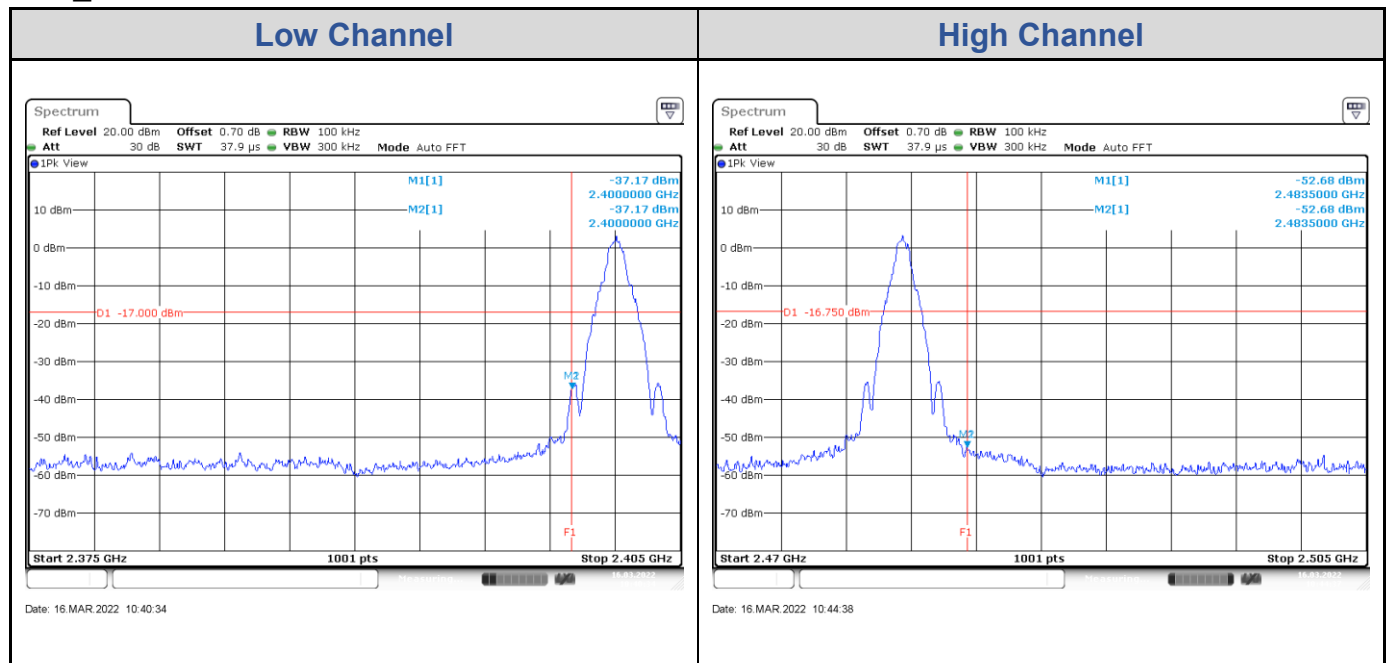

Appendix B: Test Results of Radiated Spurious Emissions & Mains

Radiated Emission Test

Band Edges, 2.31GHz ~ 2.9GHz

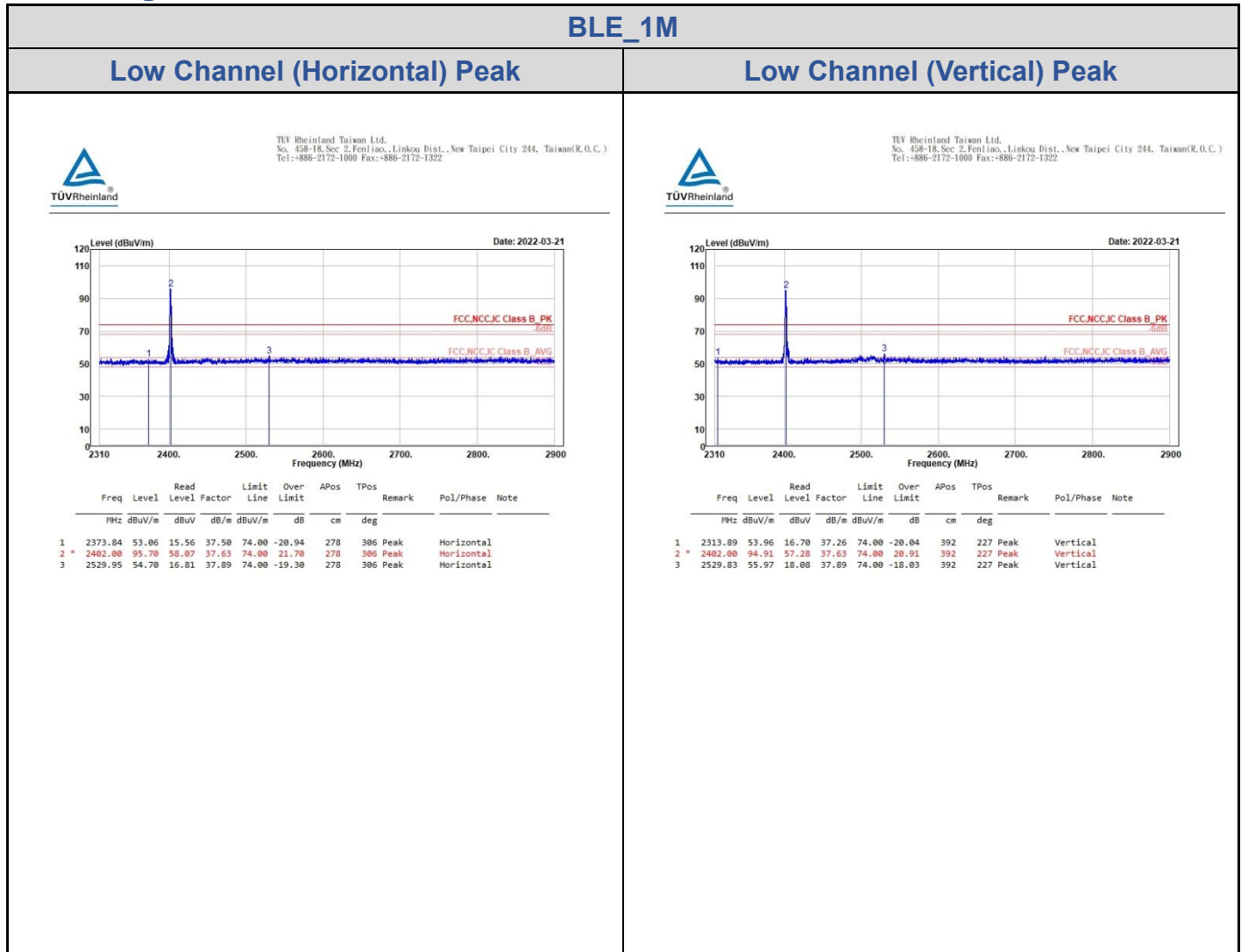

BLE_1M

Low Channel (Horizontal) Average

Low Channel (Vertical) Average



TÜV Rheinland Taiwan Ltd.
No. 438-18, Sec. 2, Fenliao, Linkou Dist., New Taipei City 244, Taiwan(R.O.C.)
Tel: +886-2172-1000 Fax: +886-2172-1322

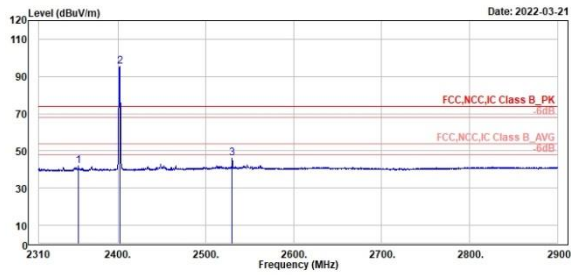

| Freq | Level | Read | Limit | Over | APos | TPos | Remark | Pol/Phase | Note |
|------|---------|-------|-------|--------|-------|--------|--------|-------------|------------|
| MHz | dBuV/m | dBuV | dB/m | dBuV/m | dB | cm | deg | | |
| 1 | 2355.19 | 42.17 | 4.77 | 37.40 | 54.00 | -11.83 | 278 | 306 Average | Horizontal |
| 2 * | 2402.00 | 95.29 | 57.66 | 37.63 | 54.00 | 41.29 | 278 | 306 Average | Horizontal |
| 3 | 2529.95 | 45.96 | 8.07 | 37.89 | 54.00 | -8.04 | 278 | 306 Average | Horizontal |



TÜV Rheinland Taiwan Ltd.
No. 438-18, Sec. 2, Fenliao, Linkou Dist., New Taipei City 244, Taiwan(R.O.C.)
Tel: +886-2172-1000 Fax: +886-2172-1322

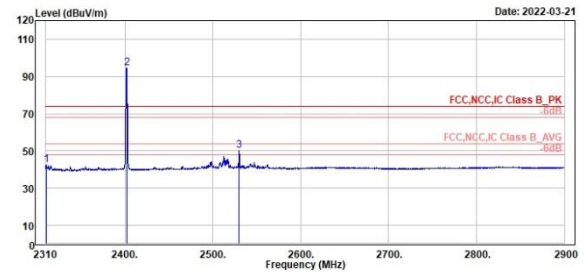

| Freq | Level | Read | Limit | Over | APos | TPos | Remark | Pol/Phase | Note |
|------|---------|-------|-------|--------|-------|--------|--------|-------------|----------|
| MHz | dBuV/m | dBuV | dB/m | dBuV/m | dB | cm | deg | | |
| 1 | 2310.59 | 42.35 | 5.10 | 37.25 | 54.00 | -11.65 | 392 | 227 Average | Vertical |
| 2 * | 2402.00 | 94.49 | 56.86 | 37.63 | 54.00 | 40.49 | 392 | 227 Average | Vertical |
| 3 ! | 2529.95 | 50.01 | 12.12 | 37.89 | 54.00 | -3.99 | 392 | 227 Average | Vertical |

BLE_1M
High Channel (Horizontal) Peak
High Channel (Vertical) Peak

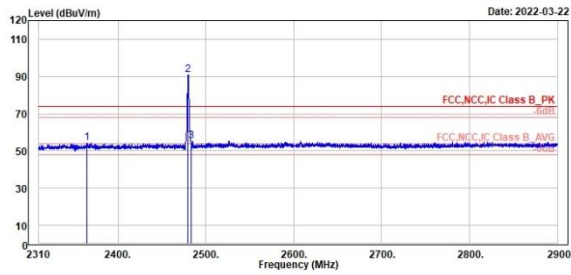

TÜV Rheinland Taiwan Ltd.
 No. 438-18, Sec. 2, Fenliao, Linkou Dist., New Taipei City 244, Taiwan(R.O.C.)
 Tel: +886-2172-1000 Fax: +886-2172-1322



| Freq | Level | Read | Level | Factor | Limit | Over | APos | TPos | Remark | Pol/Phase | Note |
|------|---------|-------|-------|--------|-------|--------|------|------|--------|------------|------|
| MHz | dBuV/m | dBuV | dB/m | dBuV/m | dB | cm | cm | deg | | | |
| 1 | 2364.75 | 54.19 | 16.74 | 37.45 | 74.00 | -19.81 | 295 | 302 | Peak | Horizontal | |
| 2 * | 2480.00 | 90.92 | 53.13 | 37.79 | 74.00 | 16.92 | 295 | 302 | Peak | Horizontal | |
| 3 | 2483.70 | 55.37 | 17.57 | 37.80 | 74.00 | -18.63 | 295 | 302 | Peak | Horizontal | |

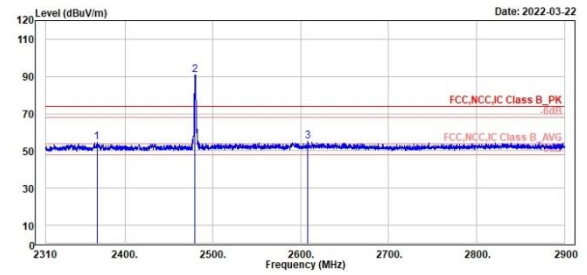

TÜV Rheinland Taiwan Ltd.
 No. 438-18, Sec. 2, Fenliao, Linkou Dist., New Taipei City 244, Taiwan(R.O.C.)
 Tel: +886-2172-1000 Fax: +886-2172-1322



| Freq | Level | Read | Level | Factor | Limit | Over | APos | TPos | Remark | Pol/Phase | Note |
|------|---------|-------|-------|--------|-------|--------|------|------|--------|-----------|------|
| MHz | dBuV/m | dBuV | dB/m | dBuV/m | dB | cm | cm | deg | | | |
| 1 | 2368.17 | 54.56 | 17.10 | 37.46 | 74.00 | -19.44 | 290 | 245 | Peak | Vertical | |
| 2 * | 2480.00 | 90.88 | 53.09 | 37.79 | 74.00 | 16.88 | 290 | 245 | Peak | Vertical | |
| 3 | 2607.95 | 55.34 | 17.36 | 37.98 | 74.00 | -18.66 | 290 | 245 | Peak | Vertical | |

BLE_1M

High Channel (Horizontal) Average

High Channel (Vertical) Average



TÜV Rheinland Taiwan Ltd.
No. 438-18, Sec. 2, Fenhiao, Linkou Dist., New Taipei City 244, Taiwan(R.O.C.)
Tel: +886-2172-1000 Fax: +886-2172-1322

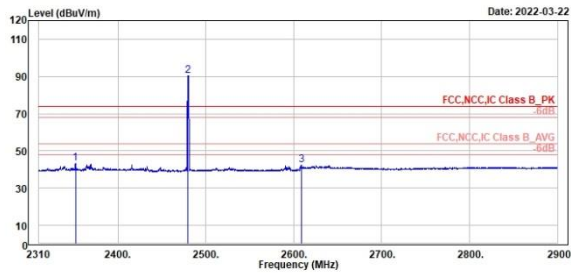

| Freq | Level | Read | Level | Factor | Limit | Over | APos | TPos | Remark | Pol/Phase | Note |
|------|---------|-------|-------|--------|-------|--------|------|------|---------|------------|------|
| MHz | dBuV/m | dBuV | dB/m | dBuV/m | dB | dB | cm | deg | | | |
| 1 | 2351.77 | 43.14 | 5.75 | 37.39 | 54.00 | -10.86 | 295 | 302 | Average | Horizontal | |
| 2 * | 2488.00 | 90.48 | 52.69 | 37.79 | 54.00 | 36.48 | 295 | 302 | Average | Horizontal | |
| 3 | 2608.54 | 42.55 | 4.57 | 37.98 | 54.00 | -11.45 | 295 | 302 | Average | Horizontal | |



TÜV Rheinland Taiwan Ltd.
No. 438-18, Sec. 2, Fenhiao, Linkou Dist., New Taipei City 244, Taiwan(R.O.C.)
Tel: +886-2172-1000 Fax: +886-2172-1322

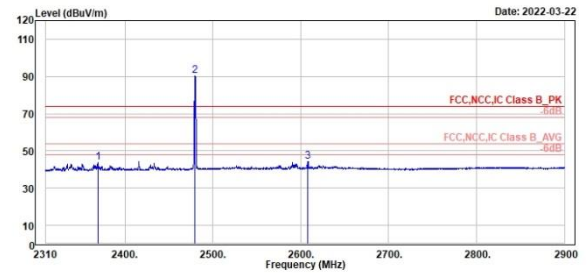

| Freq | Level | Read | Level | Factor | Limit | Over | APos | TPos | Remark | Pol/Phase | Note |
|------|---------|-------|-------|--------|-------|--------|------|------|---------|-----------|------|
| MHz | dBuV/m | dBuV | dB/m | dBuV/m | dB | dB | cm | deg | | | |
| 1 | 2369.24 | 43.71 | 6.23 | 37.48 | 54.00 | -10.29 | 290 | 245 | Average | Vertical | |
| 2 * | 2488.00 | 90.42 | 52.63 | 37.79 | 54.00 | 36.42 | 290 | 245 | Average | Vertical | |
| 3 | 2607.83 | 44.32 | 6.34 | 37.98 | 54.00 | -9.68 | 290 | 245 | Average | Vertical | |

BLE_2M
Low Channel (Horizontal) Peak
Low Channel (Vertical) Peak

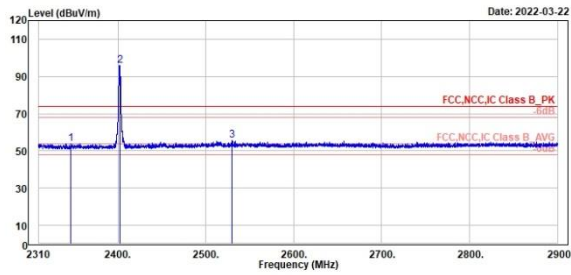

TÜV Rheinland Taiwan Ltd.
 No. 438-18, Sec. 2, Fenliao, Linkou Dist., New Taipei City 244, Taiwan(R.O.C.)
 Tel: +886-2172-1000 Fax: +886-2172-1322



| Freq | Level | Read | Limit | Over | APos | TPos | Remark | Pol/Phase | Note |
|------|---------|-------|-------|--------|-------|--------|--------|-----------|------------|
| MHz | dBuV/m | dBuV | dB/m | dBuV/m | dB | cm | deg | | |
| 1 | 2346.82 | 53.88 | 16.44 | 37.36 | 74.00 | -20.20 | 387 | 278 Peak | Horizontal |
| 2 * | 2402.80 | 95.76 | 58.13 | 37.63 | 74.00 | 21.76 | 387 | 278 Peak | Horizontal |
| 3 | 2529.83 | 55.86 | 17.97 | 37.89 | 74.00 | -18.14 | 387 | 278 Peak | Horizontal |

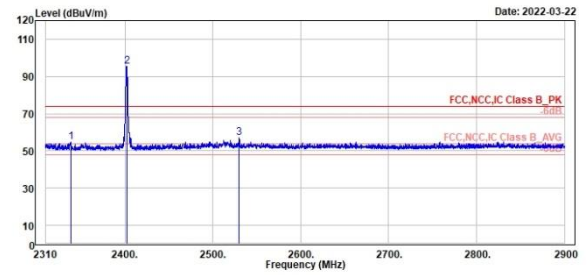

TÜV Rheinland Taiwan Ltd.
 No. 438-18, Sec. 2, Fenliao, Linkou Dist., New Taipei City 244, Taiwan(R.O.C.)
 Tel: +886-2172-1000 Fax: +886-2172-1322



| Freq | Level | Read | Limit | Over | APos | TPos | Remark | Pol/Phase | Note |
|------|---------|-------|-------|--------|-------|--------|--------|-----------|----------|
| MHz | dBuV/m | dBuV | dB/m | dBuV/m | dB | cm | deg | | |
| 1 | 2338.32 | 54.71 | 17.37 | 37.34 | 74.00 | -19.29 | 371 | 234 Peak | Vertical |
| 2 * | 2402.80 | 95.58 | 57.95 | 37.63 | 74.00 | 21.58 | 371 | 234 Peak | Vertical |
| 3 | 2530.07 | 57.07 | 19.18 | 37.89 | 74.00 | -16.93 | 371 | 234 Peak | Vertical |

BLE_2M
Low Channel (Horizontal) Average
Low Channel (Vertical) Average

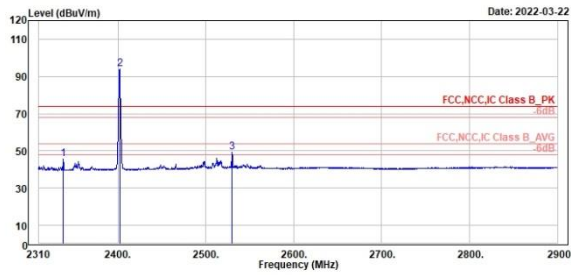

TÜV Rheinland Taiwan Ltd.
 No. 438-18, Sec. 2, Fenhiao, Linkou Dist., New Taipei City 244, Taiwan(R.O.C.)
 Tel: +886-2172-1000 Fax: +886-2172-1322



| Freq | Level | Read | Level | Factor | Limit | Over | APos | TPos | Remark | Pol/Phase | Note |
|------|---------|-------|-------|--------|-------|-------|------|------|---------|------------|------|
| MHz | dBuV/m | dBuV | dB/m | dBuV/m | dB | cm | deg | | | | |
| 1 | 2337.97 | 45.65 | 8.31 | 37.34 | 54.00 | -8.35 | 307 | 278 | Average | Horizontal | |
| 2 * | 2402.00 | 93.86 | 56.23 | 37.63 | 54.00 | 39.86 | 307 | 278 | average | Horizontal | |
| 3 ! | 2529.83 | 49.48 | 11.59 | 37.89 | 54.00 | -4.52 | 307 | 278 | Average | Horizontal | |

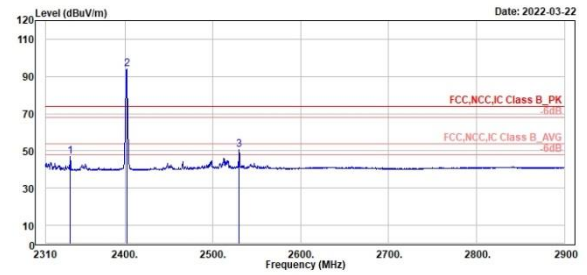

TÜV Rheinland Taiwan Ltd.
 No. 438-18, Sec. 2, Fenhiao, Linkou Dist., New Taipei City 244, Taiwan(R.O.C.)
 Tel: +886-2172-1000 Fax: +886-2172-1322



| Freq | Level | Read | Level | Factor | Limit | Over | APos | TPos | Remark | Pol/Phase | Note |
|------|---------|-------|-------|--------|-------|-------|------|------|---------|-----------|------|
| MHz | dBuV/m | dBuV | dB/m | dBuV/m | dB | cm | deg | | | | |
| 1 | 2337.97 | 46.93 | 9.59 | 37.34 | 54.00 | -7.07 | 371 | 234 | Average | Vertical | |
| 2 * | 2402.00 | 93.78 | 56.15 | 37.63 | 54.00 | 39.78 | 371 | 234 | Average | Vertical | |
| 3 ! | 2529.95 | 50.44 | 12.55 | 37.89 | 54.00 | -3.56 | 371 | 234 | Average | Vertical | |

BLE_2M
High Channel (Horizontal) Peak
High Channel (Vertical) Peak

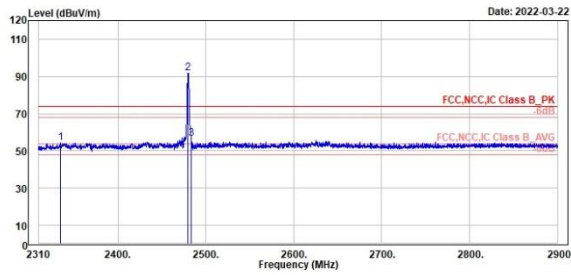

TÜV Rheinland Taiwan Ltd.
 No. 438-18, Sec. 2, Fenliao, Linkou Dist., New Taipei City 244, Taiwan(R.O.C.)
 Tel: +886-2172-1000 Fax: +886-2172-1322



| Peak | Freq (MHz) | Level (dBuV/m) | Read Level (dBuV) | Level Factor (dB/m) | Limit Line (dBuV/m) | Over Limit (dB) | APos (cm) | TPos (deg) | Remark | Pol/Phase | Note |
|------|------------|----------------|-------------------|---------------------|---------------------|-----------------|-----------|------------|--------|------------|------|
| 1 | 2334.54 | 54.51 | 17.19 | 37.32 | 74.00 | -19.49 | 296 | 300 | Peak | Horizontal | |
| 2 * | 2480.00 | 91.65 | 53.66 | 37.99 | 74.00 | 17.65 | 296 | 300 | Peak | Horizontal | |
| 3 | 2483.58 | 56.73 | 18.93 | 37.80 | 74.00 | -17.27 | 296 | 300 | Peak | Horizontal | |

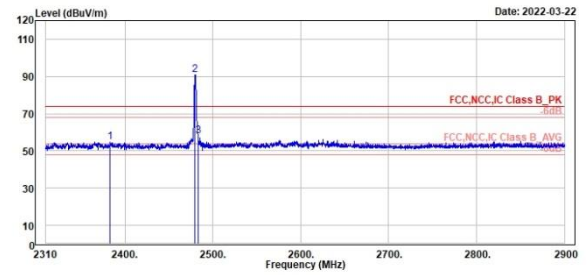

TÜV Rheinland Taiwan Ltd.
 No. 438-18, Sec. 2, Fenliao, Linkou Dist., New Taipei City 244, Taiwan(R.O.C.)
 Tel: +886-2172-1000 Fax: +886-2172-1322



| Peak | Freq (MHz) | Level (dBuV/m) | Read Level (dBuV) | Level Factor (dB/m) | Limit Line (dBuV/m) | Over Limit (dB) | APos (cm) | TPos (deg) | Remark | Pol/Phase | Note |
|------|------------|----------------|-------------------|---------------------|---------------------|-----------------|-----------|------------|--------|-----------|------|
| 1 | 2383.20 | 54.77 | 17.23 | 37.54 | 74.00 | -19.23 | 293 | 199 | Peak | Vertical | |
| 2 * | 2480.00 | 90.66 | 52.87 | 37.79 | 74.00 | 16.66 | 293 | 199 | Peak | Vertical | |
| 3 | 2483.50 | 58.01 | 20.21 | 37.80 | 74.00 | -15.99 | 293 | 199 | Peak | Vertical | |

BLE_2M

High Channel (Horizontal) Average

High Channel (Vertical) Average



TÜV Rheinland Taiwan Ltd.
No. 438-18, Sec. 2, Fenliao, Linkou Dist., New Taipei City 244, Taiwan(R.O.C.)
Tel: +886-2172-1000 Fax: +886-2172-1322

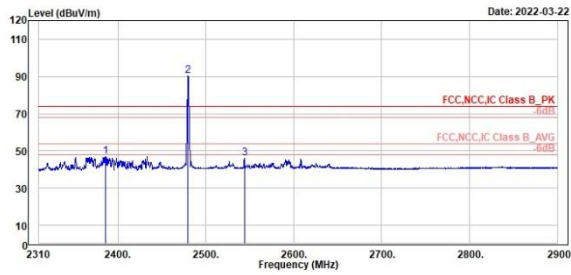

| Freq | Level | Read | Level | Factor | Limit | Over | APos | TPos | Remark | Pol/Phase | Note |
|------|---------|-------|-------|--------|-------|-------|------|------|---------|------------|------|
| MHz | dBuV/m | dBuV | dB/m | dBuV/m | dB | dB | cm | deg | | | |
| 1 | 2386.11 | 46.90 | 9.34 | 37.56 | 54.00 | -7.10 | 296 | 300 | Average | Horizontal | |
| 2 * | 2488.00 | 90.32 | 52.53 | 37.79 | 54.00 | 36.32 | 296 | 300 | average | Horizontal | |
| 3 | 2543.99 | 46.07 | 8.17 | 37.90 | 54.00 | -7.93 | 296 | 300 | Average | Horizontal | |



TÜV Rheinland Taiwan Ltd.
No. 438-18, Sec. 2, Fenliao, Linkou Dist., New Taipei City 244, Taiwan(R.O.C.)
Tel: +886-2172-1000 Fax: +886-2172-1322

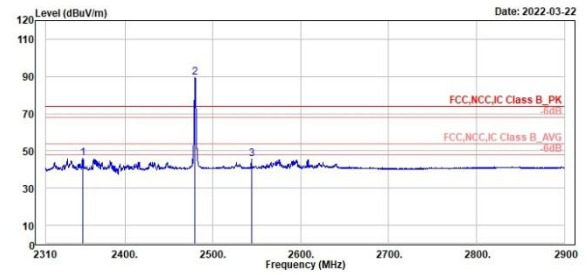

| Freq | Level | Read | Level | Factor | Limit | Over | APos | TPos | Remark | Pol/Phase | Note |
|------|---------|-------|-------|--------|-------|-------|------|------|---------|-----------|------|
| MHz | dBuV/m | dBuV | dB/m | dBuV/m | dB | dB | cm | deg | | | |
| 1 | 2352.60 | 45.98 | 8.59 | 37.39 | 54.00 | -8.02 | 293 | 199 | Average | Vertical | |
| 2 * | 2488.00 | 89.32 | 51.53 | 37.79 | 54.00 | 35.32 | 293 | 199 | Average | Vertical | |
| 3 | 2543.99 | 45.43 | 7.53 | 37.90 | 54.00 | -8.57 | 293 | 199 | Average | Vertical | |

Spurious Emissions, Tx Mode, 9kHz ~ 30MHz

BLE_1M

Low Channel (Open) 9kHz~150kHz

Low Channel (Open) 150kHz~30MHz



TUV Rheinland Taiwan Ltd.
No. 438-18, Sec. 2, Fenliao, Linkou Dist., New Taipei City 244, Taiwan(R.O.C.)
Tel: +886-2172-1000 Fax: +886-2172-1322

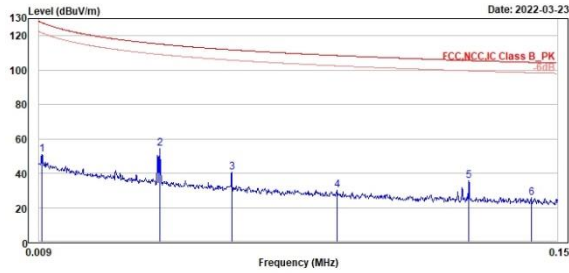

| Freq | Level | Read | Limit | Over | APos | TPos | Remark | Pol/Phase | Note |
|------|--------|-------|-------|--------|--------|--------|--------|-----------|------|
| MHz | dBuV/m | dBuV | dB/m | dBuV/m | dB | cm | deg | | |
| 1 | 0.01 | 50.75 | 32.99 | 17.76 | 127.72 | -76.97 | 100 | 270 QP | Open |
| 2 | 0.04 | 54.19 | 34.80 | 19.39 | 115.16 | -60.97 | 100 | 84 QP | Open |
| 3 | 0.06 | 40.36 | 21.30 | 19.06 | 111.82 | -71.46 | 100 | 25 QP | Open |
| 4 | 0.09 | 30.01 | 11.58 | 18.43 | 108.49 | -78.48 | 100 | 200 QP | Open |
| 5 | 0.13 | 35.49 | 17.18 | 18.31 | 105.60 | -70.11 | 100 | 205 QP | Open |
| 6 | 0.14 | 25.65 | 7.28 | 18.37 | 104.50 | -78.85 | 100 | 57 QP | Open |



TUV Rheinland Taiwan Ltd.
No. 438-18, Sec. 2, Fenliao, Linkou Dist., New Taipei City 244, Taiwan(R.O.C.)
Tel: +886-2172-1000 Fax: +886-2172-1322

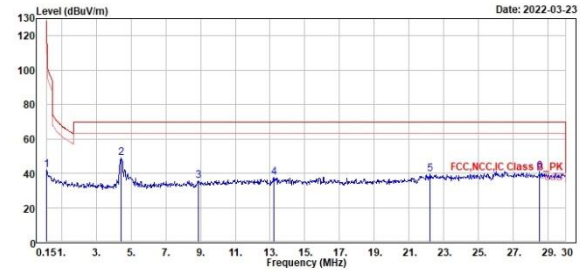

| Freq | Level | Read | Limit | Over | APos | TPos | Remark | Pol/Phase | Note |
|------|--------|-------|-------|--------|--------|--------|--------|-----------|------|
| MHz | dBuV/m | dBuV | dB/m | dBuV/m | dB | cm | deg | | |
| 1 | 0.15 | 42.17 | 23.77 | 18.40 | 104.80 | -61.91 | 100 | 147 QP | Open |
| 2 | 4.45 | 49.04 | 29.63 | 19.41 | 69.50 | -20.46 | 100 | 205 QP | Open |
| 3 | 8.90 | 35.69 | 14.72 | 20.97 | 69.50 | -33.81 | 100 | 150 QP | Open |
| 4 | 13.22 | 37.46 | 15.74 | 21.72 | 69.50 | -32.04 | 100 | 85 QP | Open |
| 5 | 22.21 | 39.33 | 17.03 | 22.30 | 69.50 | -30.17 | 100 | 105 QP | Open |
| 6 | 28.51 | 41.27 | 18.68 | 22.59 | 69.50 | -28.23 | 100 | 308 QP | Open |

BLE_1M

Low Channel (Close) 9kHz~150kHz

Low Channel (Close) 150kHz~30MHz



TUV Rheinland Taiwan Ltd.
No. 438-18, Sec. 2, Fenliao, Linkou Dist., New Taipei City 244, Taiwan(R.O.C.)
Tel: +886-2172-1000 Fax: +886-2172-1322

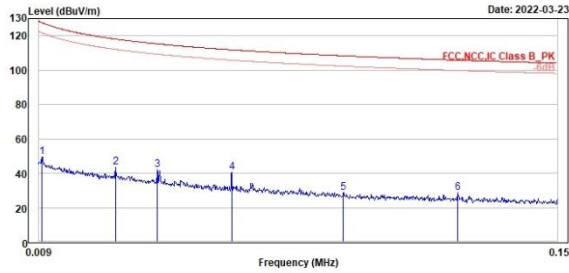

| Freq | Level | Read | Limit | Over | Apos | Tpos | Remark | Pol/Phase | Note |
|------|--------|-------|-------|--------|--------|--------|--------|-----------|-------|
| MHz | dBuV/m | dBuV | dB/m | dBuV/m | dB | cm | deg | | |
| 1 | 0.01 | 49.32 | 31.56 | 17.76 | 127.72 | -78.48 | 100 | 177 QP | Close |
| 2 | 0.03 | 43.27 | 23.77 | 19.50 | 118.09 | -74.82 | 100 | 248 QP | Close |
| 3 | 0.04 | 42.18 | 22.78 | 19.40 | 115.28 | -73.10 | 100 | 261 QP | Close |
| 4 | 0.06 | 40.67 | 21.61 | 19.06 | 111.82 | -71.15 | 100 | 254 QP | Close |
| 5 | 0.09 | 28.61 | 10.22 | 18.39 | 108.34 | -79.73 | 100 | 325 QP | Close |
| 6 | 0.12 | 28.58 | 10.28 | 18.30 | 105.00 | -77.22 | 100 | 64 QP | Close |



TUV Rheinland Taiwan Ltd.
No. 438-18, Sec. 2, Fenliao, Linkou Dist., New Taipei City 244, Taiwan(R.O.C.)
Tel: +886-2172-1000 Fax: +886-2172-1322

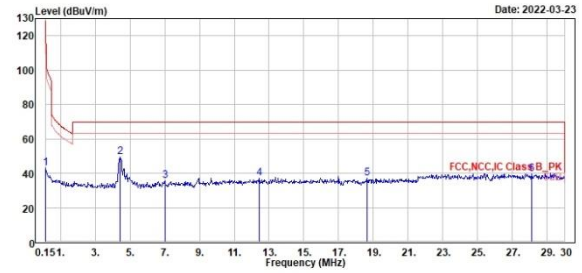

| Freq | Level | Read | Limit | Over | Apos | Tpos | Remark | Pol/Phase | Note |
|------|--------|-------|-------|--------|--------|--------|--------|-----------|-------|
| MHz | dBuV/m | dBuV | dB/m | dBuV/m | dB | cm | deg | | |
| 1 | 0.15 | 43.04 | 24.64 | 18.40 | 104.00 | -61.04 | 100 | 352 QP | Close |
| 2 | 4.45 | 49.41 | 30.00 | 19.41 | 69.50 | -20.09 | 100 | 236 QP | Close |
| 3 | 7.02 | 35.72 | 15.52 | 20.20 | 69.50 | -33.78 | 100 | 18 QP | Close |
| 4 | 12.42 | 37.24 | 15.57 | 21.67 | 69.50 | -32.26 | 100 | 40 QP | Close |
| 5 | 18.66 | 37.08 | 14.97 | 22.11 | 69.50 | -32.42 | 100 | 242 QP | Close |
| 6 | 28.09 | 39.54 | 16.98 | 22.56 | 69.50 | -29.96 | 100 | 309 QP | Close |

Spurious Emissions, Tx Mode, 30MHz ~ 1GHz

BLE_1M

Low Channel (Horizontal)

Low Channel (Vertical)



TÜV Rheinland Taiwan Ltd.
No. 438-18, Sec. 2, Fenliao, Linkou Dist., New Taipei City 244, Taiwan(R.O.C.)
Tel: +886-2172-1000 Fax: +886-2172-1322

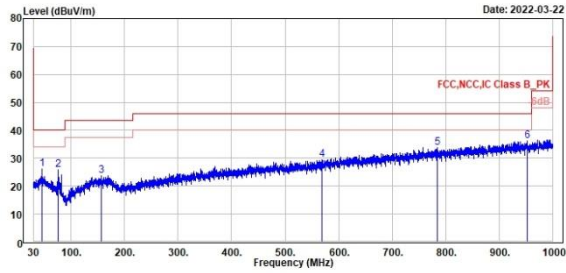

| Freq | Level | Read | Limit | Over | APos | TPos | Remark | Pol/Phase | Note |
|------|--------|-------|-------|--------|-------|--------|--------|-----------|------------|
| MHz | dBuV/m | dBuV | dB/m | dBuV/m | dB | cm | deg | | |
| 1 | 45.33 | 26.10 | 32.03 | -5.93 | 40.00 | -13.90 | 325 | 40 QP | Horizontal |
| 2 | 76.17 | 25.82 | 35.47 | -9.65 | 40.00 | -14.18 | 300 | 165 QP | Horizontal |
| 3 | 157.07 | 23.80 | 29.59 | -5.79 | 43.50 | -19.70 | 280 | 134 QP | Horizontal |
| 4 | 569.61 | 29.38 | 29.78 | -0.40 | 46.00 | -16.62 | 112 | 328 QP | Horizontal |
| 5 | 784.95 | 33.72 | 30.67 | 3.05 | 46.00 | -12.28 | 400 | 295 QP | Horizontal |
| 6 | 952.37 | 36.26 | 30.81 | 5.45 | 46.00 | -9.74 | 107 | 219 QP | Horizontal |



TÜV Rheinland Taiwan Ltd.
No. 438-18, Sec. 2, Fenliao, Linkou Dist., New Taipei City 244, Taiwan(R.O.C.)
Tel: +886-2172-1000 Fax: +886-2172-1322

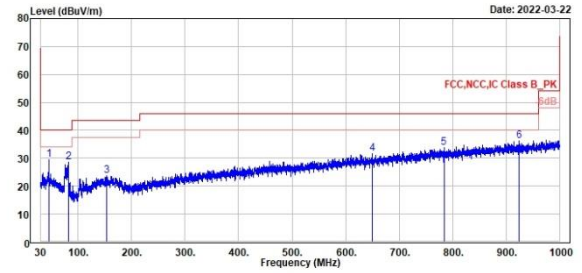

| Freq | Level | Read | Limit | Over | APos | TPos | Remark | Pol/Phase | Note |
|------|--------|-------|-------|--------|-------|--------|--------|-----------|----------|
| MHz | dBuV/m | dBuV | dB/m | dBuV/m | dB | cm | deg | | |
| 1 | 45.33 | 29.61 | 35.54 | -5.93 | 40.00 | -10.39 | 100 | 248 QP | Vertical |
| 2 | 81.51 | 28.51 | 39.28 | -10.77 | 40.00 | -11.49 | 210 | 174 QP | Vertical |
| 3 | 153.00 | 23.59 | 29.51 | -5.92 | 43.50 | -19.91 | 102 | 69 QP | Vertical |
| 4 | 650.12 | 31.54 | 30.63 | 0.91 | 46.00 | -14.46 | 300 | 118 QP | Vertical |
| 5 | 783.88 | 33.64 | 30.57 | 3.07 | 46.00 | -12.36 | 100 | 108 QP | Vertical |
| 6 | 924.05 | 36.15 | 31.06 | 5.09 | 46.00 | -9.85 | 100 | 325 QP | Vertical |

Spurious Emissions, Tx Mode, 1GHz ~ 26.5GHz

BLE_1M

Low Channel (Horizontal)

Low Channel (Vertical)



TÜV Rheinland Taiwan Ltd.
No. 438-18, Sec. 2, Fenliao, Linkou Dist., New Taipei City 244, Taiwan(R.O.C.)
Tel: +886-2172-1000 Fax: +886-2172-1322

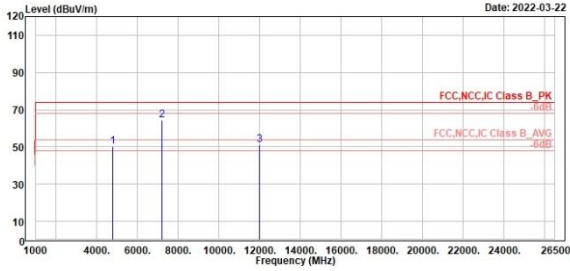

| 1 | 2 | 3 | | | | | | | |
|----------|--------|-------|-------|--------|--------|------|----------|------------|------|
| Freq | Level | Read | Limit | Over | APos | TPos | Remark | Pol/Phase | Note |
| MHz | dBuV/m | dBuV | dB/m | dBuV/m | dB | cm | deg | | |
| 4894.00 | 50.03 | 59.90 | -9.87 | 74.00 | -23.97 | 100 | 342 Peak | Horizontal | |
| 7286.00 | 64.35 | 71.68 | -7.33 | 74.00 | -9.65 | 300 | 38 Peak | Horizontal | |
| 12818.00 | 50.97 | 51.21 | -0.24 | 74.00 | -23.03 | 300 | 199 Peak | Horizontal | |



TÜV Rheinland Taiwan Ltd.
No. 438-18, Sec. 2, Fenliao, Linkou Dist., New Taipei City 244, Taiwan(R.O.C.)
Tel: +886-2172-1000 Fax: +886-2172-1322

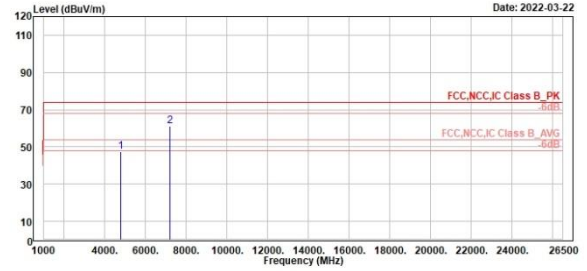

| 1 | 2 | | | | | | | | |
|---------|--------|-------|-------|--------|--------|------|----------|-----------|------|
| Freq | Level | Read | Limit | Over | APos | TPos | Remark | Pol/Phase | Note |
| MHz | dBuV/m | dBuV | dB/m | dBuV/m | dB | cm | deg | | |
| 4894.00 | 47.46 | 57.33 | -9.87 | 74.00 | -26.54 | 300 | 279 Peak | Vertical | |
| 7286.00 | 61.28 | 68.61 | -7.33 | 74.00 | -12.72 | 400 | 283 Peak | Vertical | |

BLE_1M

Middle Channel (Horizontal)

Middle Channel (Vertical)



TÜV Rheinland Taiwan Ltd.
No. 438-18, Sec. 2, Fenliao, Linkou Dist., New Taipei City 244, Taiwan(R.O.C.)
Tel: +886-2172-1000 Fax: +886-2172-1322



TÜV Rheinland Taiwan Ltd.
No. 438-18, Sec. 2, Fenliao, Linkou Dist., New Taipei City 244, Taiwan(R.O.C.)
Tel: +886-2172-1000 Fax: +886-2172-1322

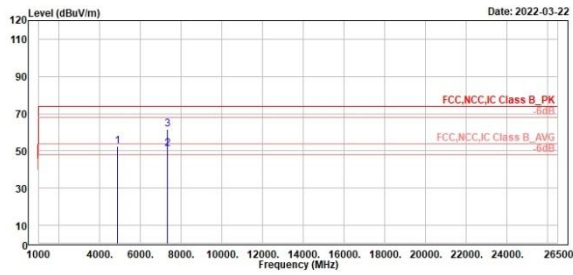

| Freq | Level | Read Level | Factor | Limit Line | Over Limit | APos | TPos | Remark | Pol/Phase | Note |
|------|---------|------------|--------|------------|------------|--------|------|-------------|------------|------|
| MHz | dBuV/m | dBuV | dB/m | dBuV/m | dB | cm | deg | | | |
| 1 | 4880.00 | 52.41 | 62.20 | -9.79 | 74.00 | -21.59 | 100 | 332 Peak | Horizontal | |
| 2 | 7320.00 | 50.95 | 58.44 | -7.49 | 54.00 | -3.05 | 400 | 207 Average | Horizontal | |
| 3 | 7320.00 | 61.43 | 68.92 | -7.49 | 74.00 | -12.57 | 400 | 207 Peak | Horizontal | |

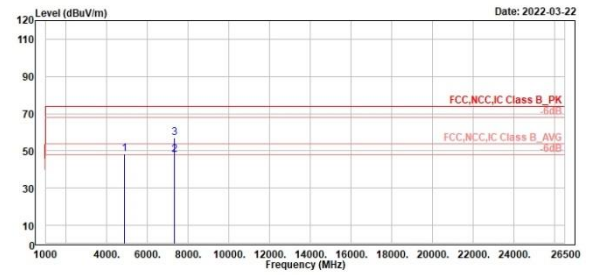

| Freq | Level | Read Level | Factor | Limit Line | Over Limit | APos | TPos | Remark | Pol/Phase | Note |
|------|---------|------------|--------|------------|------------|--------|------|-------------|-----------|------|
| MHz | dBuV/m | dBuV | dB/m | dBuV/m | dB | cm | deg | | | |
| 1 | 4880.00 | 48.48 | 58.27 | -9.79 | 74.00 | -25.52 | 300 | 79 Peak | Vertical | |
| 2 | 7320.00 | 47.80 | 55.29 | -7.49 | 54.00 | -6.20 | 400 | 113 Average | Vertical | |
| 3 | 7320.00 | 56.99 | 64.48 | -7.49 | 74.00 | -17.01 | 400 | 113 Peak | Vertical | |

BLE_1M

High Channel (Horizontal)

High Channel (Vertical)



TÜV Rheinland Taiwan Ltd.
No. 438-18, Sec. 2, Fenliao, Linkou Dist., New Taipei City 244, Taiwan(R.O.C.)
Tel: +886-2172-1000 Fax: +886-2172-1322

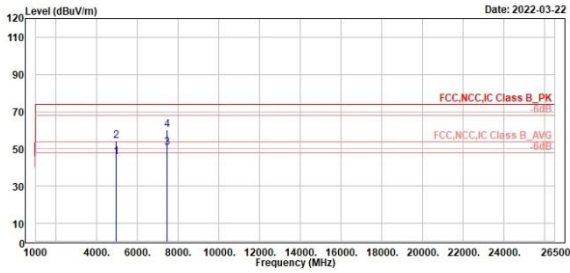

| Freq | Level | Read Level | Factor | Limit Line | Over Limit | APos | TPos | Remark | Pol/Phase | Note |
|------|---------|------------|--------|------------|------------|--------|------|-------------|------------|------|
| MHz | dBuV/m | dBuV | dB/m | dBuV/m | dB | cm | deg | | | |
| 1 | 4968.00 | 45.48 | 54.94 | -9.54 | 54.00 | -8.68 | 280 | 322 Average | Horizontal | |
| 2 | 4968.00 | 54.47 | 64.01 | -9.54 | 74.00 | -19.53 | 280 | 322 Peak | Horizontal | |
| 3 | 7448.00 | 50.87 | 58.22 | -7.35 | 54.00 | -3.13 | 400 | 197 Average | Horizontal | |
| 4 | 7448.00 | 60.34 | 67.69 | -7.35 | 74.00 | -13.66 | 400 | 197 Peak | Horizontal | |



TÜV Rheinland Taiwan Ltd.
No. 438-18, Sec. 2, Fenliao, Linkou Dist., New Taipei City 244, Taiwan(R.O.C.)
Tel: +886-2172-1000 Fax: +886-2172-1322

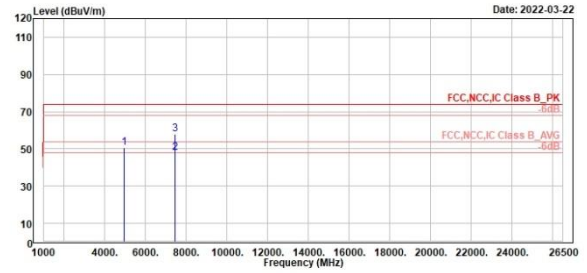

| Freq | Level | Read Level | Factor | Limit Line | Over Limit | APos | TPos | Remark | Pol/Phase | Note |
|------|---------|------------|--------|------------|------------|--------|------|-------------|-----------|------|
| MHz | dBuV/m | dBuV | dB/m | dBuV/m | dB | cm | deg | | | |
| 1 | 4968.00 | 50.84 | 60.38 | -9.54 | 74.00 | -23.16 | 400 | 211 Peak | Vertical | |
| 2 | 7448.00 | 47.93 | 55.28 | -7.35 | 54.00 | -6.07 | 400 | 106 Average | Vertical | |
| 3 | 7448.00 | 58.10 | 65.45 | -7.35 | 74.00 | -15.90 | 400 | 106 Peak | Vertical | |

BLE_2M
Low Channel (Horizontal)
Low Channel (Vertical)

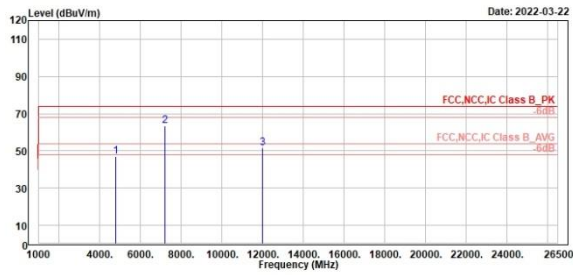

TÜV Rheinland Taiwan Ltd.
 No. 438-18, Sec. 2, Fenliao, Linkou Dist., New Taipei City 244, Taiwan(R.O.C.)
 Tel: +886-2172-1000 Fax: +886-2172-1322



| Freq | Level | Read Level | Factor | Limit Line | Over Limit | APos | TPos | Remark | Pol/Phase | Note |
|------|----------|------------|--------|------------|------------|--------|------|----------|------------|------|
| MHz | dBuV/m | dBuV | dB/m | dBuV/m | dB | cm | deg | | | |
| 1 | 4984.00 | 46.83 | 56.70 | -9.87 | 74.00 | -27.17 | 100 | 291 Peak | Horizontal | |
| 2 | 7286.00 | 63.31 | 70.64 | -7.33 | 74.00 | -10.69 | 100 | 97 Peak | Horizontal | |
| 3 | 12818.00 | 51.39 | 51.63 | -0.24 | 74.00 | -22.61 | 100 | 214 Peak | Horizontal | |

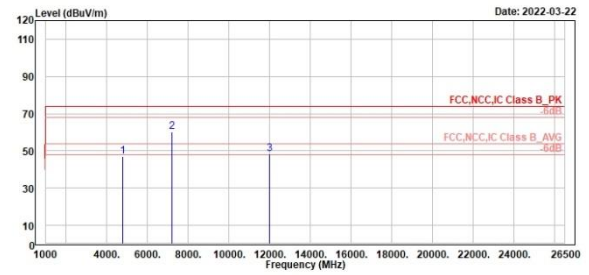

TÜV Rheinland Taiwan Ltd.
 No. 438-18, Sec. 2, Fenliao, Linkou Dist., New Taipei City 244, Taiwan(R.O.C.)
 Tel: +886-2172-1000 Fax: +886-2172-1322



| Freq | Level | Read Level | Factor | Limit Line | Over Limit | APos | TPos | Remark | Pol/Phase | Note |
|------|----------|------------|--------|------------|------------|--------|------|----------|-----------|------|
| MHz | dBuV/m | dBuV | dB/m | dBuV/m | dB | cm | deg | | | |
| 1 | 4984.00 | 47.00 | 56.87 | -9.87 | 74.00 | -27.00 | 300 | 207 Peak | Vertical | |
| 2 | 7286.00 | 60.34 | 67.67 | -7.33 | 74.00 | -13.66 | 400 | 284 Peak | Vertical | |
| 3 | 12818.00 | 48.23 | 48.47 | -0.24 | 74.00 | -25.77 | 300 | 47 Peak | Vertical | |

BLE_2M

Middle Channel (Horizontal)

Middle Channel (Vertical)



TÜV Rheinland Taiwan Ltd.
No. 438-18, Sec. 2, Fenliao, Linkou Dist., New Taipei City 244, Taiwan(R.O.C.)
Tel: +886-2172-1000 Fax: +886-2172-1322



TÜV Rheinland Taiwan Ltd.
No. 438-18, Sec. 2, Fenliao, Linkou Dist., New Taipei City 244, Taiwan(R.O.C.)
Tel: +886-2172-1000 Fax: +886-2172-1322

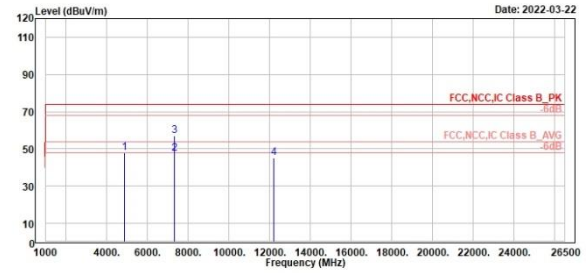
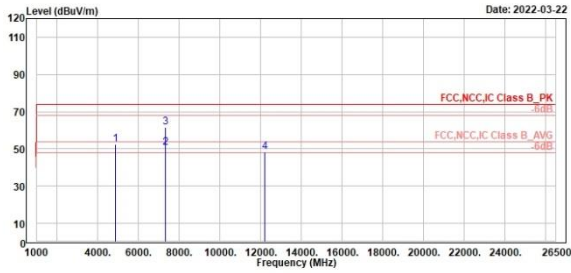

| Line | Freq | Level | Read Level | Factor | Limit Line | Over Limit | APos | TPos | Remark | Pol/Phase | Note |
|------|----------|--------|------------|--------|------------|------------|------|------|---------|------------|------|
| | MHz | dBuV/m | dBuV | dB/m | dBuV/m | dB | cm | deg | | | |
| 1 | 4880.00 | 52.51 | 62.30 | -9.79 | 74.00 | -21.49 | 100 | 328 | Peak | Horizontal | |
| 2 | 7320.00 | 50.87 | 58.36 | -7.49 | 54.00 | -3.13 | 400 | 208 | Average | Horizontal | |
| 3 | 7320.00 | 61.48 | 68.97 | -7.49 | 74.00 | -12.52 | 400 | 208 | Peak | Horizontal | |
| 4 | 12200.00 | 48.46 | 48.48 | -0.02 | 74.00 | -25.54 | 100 | 292 | Peak | Horizontal | |

| Line | Freq | Level | Read Level | Factor | Limit Line | Over Limit | APos | TPos | Remark | Pol/Phase | Note |
|------|----------|--------|------------|--------|------------|------------|------|------|---------|-----------|------|
| | MHz | dBuV/m | dBuV | dB/m | dBuV/m | dB | cm | deg | | | |
| 1 | 4880.00 | 47.90 | 57.69 | -9.79 | 74.00 | -26.10 | 300 | 81 | Peak | Vertical | |
| 2 | 7320.00 | 47.63 | 55.12 | -7.49 | 54.00 | -6.37 | 400 | 101 | Average | Vertical | |
| 3 | 7320.00 | 57.00 | 64.49 | -7.49 | 74.00 | -17.00 | 400 | 101 | Peak | Vertical | |
| 4 | 12200.00 | 45.39 | 45.41 | -0.02 | 74.00 | -28.61 | 100 | 153 | Peak | Vertical | |

BLE_2M

High Channel (Horizontal)

High Channel (Vertical)



TÜV Rheinland Taiwan Ltd.
No. 438-18, Sec. 2, Fenliao, Linkou Dist., New Taipei City 244, Taiwan(R.O.C.)
Tel: +886-2172-1000 Fax: +886-2172-1322



TÜV Rheinland Taiwan Ltd.
No. 438-18, Sec. 2, Fenliao, Linkou Dist., New Taipei City 244, Taiwan(R.O.C.)
Tel: +886-2172-1000 Fax: +886-2172-1322

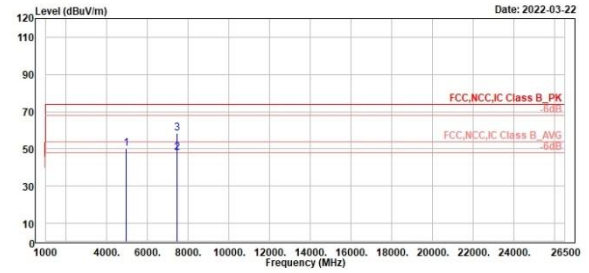
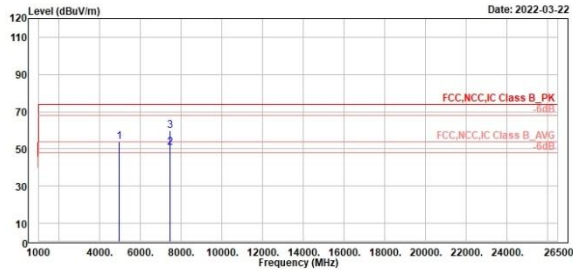

| Freq | Level | Read Level | Factor | Limit Line | Over Limit | APos | TPos | Remark | Pol/Phase | Note |
|------|---------|------------|--------|------------|------------|--------|------|-------------|------------|------|
| MHz | dBuV/m | dBuV | dB/m | dBuV/m | dB | cm | deg | | | |
| 1 | 4968.00 | 53.95 | 63.49 | -9.54 | 74.00 | -20.05 | 200 | 324 Peak | Horizontal | |
| 2 | 7440.00 | 58.83 | 58.18 | -7.35 | 54.00 | -3.17 | 400 | 187 Average | Horizontal | |
| 3 | 7440.00 | 59.67 | 67.02 | -7.35 | 74.00 | -14.33 | 400 | 187 Peak | Horizontal | |

| Freq | Level | Read Level | Factor | Limit Line | Over Limit | APos | TPos | Remark | Pol/Phase | Note |
|------|---------|------------|--------|------------|------------|--------|------|-------------|-----------|------|
| MHz | dBuV/m | dBuV | dB/m | dBuV/m | dB | cm | deg | | | |
| 1 | 4968.00 | 58.37 | 59.91 | -9.54 | 74.00 | -23.63 | 400 | 198 Peak | Vertical | |
| 2 | 7440.00 | 47.94 | 55.29 | -7.35 | 54.00 | -6.06 | 400 | 105 Average | Vertical | |
| 3 | 7440.00 | 58.26 | 65.61 | -7.35 | 74.00 | -15.74 | 400 | 105 Peak | Vertical | |

Mains Conducted Emission, 150kHz ~ 30MHz

Worst Band

(Line)

(Neutral)



TUV Rheinland Taiwan Ltd.
No. 458-18, Sec. 2, Fenhiao, Linkou Dist., New Taipei City 244, Taiwan(R.O.C.)
Tel: +886-2112-1000 Fax: +886-2112-1322

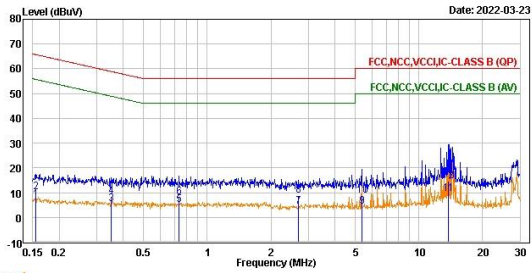

Trace: 1

| Line | Freq | Level | Read Level | Factor | Limit | Over Limit | Remark | Pol/Phase | Note |
|------|-------|-------|------------|--------|-------|------------|---------|-----------|------|
| | MHz | dBuV | dBuV | dB | dBuV | dB | | | |
| 1 | 0.15 | 6.99 | -2.70 | 9.69 | 55.75 | -48.76 | Average | line1 | |
| 2 | 0.15 | 10.34 | 0.65 | 9.69 | 65.75 | -55.41 | QP | line1 | |
| 3 | 0.35 | 5.55 | -4.13 | 9.68 | 46.92 | -43.37 | Average | line1 | |
| 4 | 0.35 | 8.59 | -1.09 | 9.68 | 58.92 | -50.33 | QP | line1 | |
| 5 | 0.74 | 5.22 | -4.47 | 9.69 | 46.00 | -40.78 | Average | line1 | |
| 6 | 0.74 | 8.08 | -1.61 | 9.69 | 56.00 | -47.92 | QP | line1 | |
| 7 | 2.70 | 4.34 | -5.38 | 9.72 | 46.00 | -41.66 | Average | line1 | |
| 8 | 2.70 | 8.82 | -0.90 | 9.72 | 56.00 | -47.18 | QP | line1 | |
| 9 | 5.37 | 4.33 | -5.43 | 9.76 | 50.00 | -45.67 | Average | line1 | |
| 10 | 5.37 | 8.93 | -0.83 | 9.76 | 60.00 | -51.07 | QP | line1 | |
| 11 | 13.72 | 9.47 | -0.34 | 9.81 | 50.00 | -40.53 | Average | line1 | |
| 12 | 13.72 | 14.65 | 4.84 | 9.81 | 60.00 | -45.35 | QP | line1 | |



TUV Rheinland Taiwan Ltd.
No. 458-18, Sec. 2, Fenhiao, Linkou Dist., New Taipei City 244, Taiwan(R.O.C.)
Tel: +886-2112-1000 Fax: +886-2112-1322

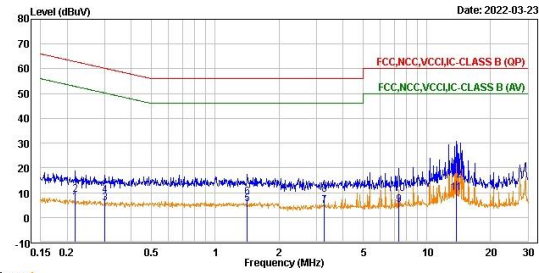

Trace: 1

| Line | Freq | Level | Read Level | Factor | Limit | Over Limit | Remark | Pol/Phase | Note |
|------|-------|-------|------------|--------|-------|------------|---------|-----------|------|
| | MHz | dBuV | dBuV | dB | dBuV | dB | | | |
| 1 | 0.22 | 6.19 | -3.47 | 9.66 | 52.00 | -46.71 | Average | neutral | |
| 2 | 0.22 | 9.22 | -0.44 | 9.66 | 62.00 | -53.68 | QP | neutral | |
| 3 | 0.30 | 5.78 | -3.87 | 9.65 | 50.20 | -44.42 | Average | neutral | |
| 4 | 0.30 | 8.82 | -0.83 | 9.65 | 60.20 | -51.38 | QP | neutral | |
| 5 | 1.42 | 5.23 | -4.45 | 9.68 | 46.00 | -40.77 | Average | neutral | |
| 6 | 1.42 | 7.98 | -1.70 | 9.68 | 56.00 | -48.02 | QP | neutral | |
| 7 | 3.26 | 4.73 | -4.98 | 9.71 | 46.00 | -41.27 | Average | neutral | |
| 8 | 3.26 | 9.28 | -0.43 | 9.71 | 56.00 | -46.72 | QP | neutral | |
| 9 | 7.36 | 4.99 | -4.78 | 9.77 | 50.00 | -45.01 | Average | neutral | |
| 10 | 7.36 | 9.55 | -0.22 | 9.77 | 60.00 | -50.45 | QP | neutral | |
| 11 | 13.72 | 9.91 | 0.08 | 9.83 | 50.00 | -40.09 | Average | neutral | |
| 12 | 13.72 | 14.94 | 5.11 | 9.83 | 60.00 | -45.06 | QP | neutral | |