

FCC Radio Test Report

Product Name:	Wireless USB Adapter
Trademark:	N/A
FCC ID:	YWTWF7610U5B
Model Name :	GWF-5B06
Prepared For :	Shenzhen Ogemray Technology Co., Ltd.
Address :	3/F,No.9 Bldg.Minxing Industrial Park.Minkang Rd. Minzhi St. Baoan District.Shenzhen, China
Prepared By :	DongGuan Precise Testing Service Co., Ltd.
Address :	Building D, Baoding Technology Park, Guangming Road 2, Guangming Community, Dongcheng District, Dongguan, Guangdong, China
Test Date:	Sept. 03 - Sept. 15, 2015
Date of Report :	Sept. 16, 2015
Report No.:	PT1509018003F-3

VERIFICATION OF COMPLIANCE

Applicant's name : **Shenzhen Ogemray Technology Co., Ltd.**
Address : 3/F,No.9 Bldg.Minxing Industrial Park.Minkang Rd. Minzhi St.
Baoan District.Shenzhen, China
Manufacture's Name..... : **Shenzhen Ogemray Technology Co., Ltd.**
Address : 3/F,No.9 Bldg.Minxing Industrial Park.Minkang Rd. Minzhi St.
Baoan District.Shenzhen, China

Product description

Product name : Wireless USB Adapter
Trademark: N/A
Model Name: GWF-5B06
Test procedure FCC Part15.407
Standards ANSI C63.10:2013

This device described above has been tested by PTS, and the test results show that the equipment under test (EUT) is in compliance with the FCC requirements. And it is applicable only to the tested sample identified in the report.

This report shall not be reproduced except in full, without the written approval of PTS, this document may be altered or revised by PTS, personal only, and shall be noted in the revision of the document.

Test Result..... : **Pass**

Testing Engineer : 

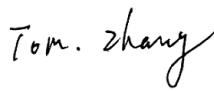
(Juan Zeng)
Technical Manager : 

(Tom Zhang)
Authorized Signatory : 

(Chris Du)

Table of Contents

	Page
1 . SUMMARY OF TEST RESULTS	6
1.1 TEST FACILITY	7
1.2 MEASUREMENT UNCERTAINTY	7
2 . GENERAL INFORMATION	8
2.1 GENERAL DESCRIPTION OF EUT	8
2.2 DESCRIPTION OF TEST MODES	10
2.3 BLOCK DIGRAM SHOWING THE CONFIGURATION OF SYSTEM TESTED	11
2.4 DESCRIPTION OF SUPPORT UNITS(CONDUCTED MODE)	12
2.5 EQUIPMENTS LIST FOR ALL TEST ITEMS	13
FOR RADIATED EMISSION TEST (BELOW 1GHZ)	13
FOR RADIATED EMISSION TEST (1GHZ ABOVE)	13
3 . EMC EMISSION TEST	15
3.1 CONDUCTED EMISSION MEASUREMENT	15
3.1.1 POWER LINE CONDUCTED EMISSION LIMITS	15
3.1.2 TEST PROCEDURE	16
3.1.3 DEVIATION FROM TEST STANDARD	16
3.1.4 TEST SETUP	16
3.1.5 EUT OPERATING CONDITIONS	16
3.1.6 TEST RESULTS	17
3.2 RADIATED EMISSION MEASUREMENT	19
3.2.1 RADIATED EMISSION LIMITS	19
3.2.2 TEST PROCEDURE	20
3.2.3 DEVIATION FROM TEST STANDARD	20
3.2.4 TEST SETUP	21
3.2.5 EUT OPERATING CONDITIONS	22
3.2.6 TEST RESULTS (BETWEEN 9KHZ – 30 MHZ)	23
3.2.7 TEST RESULTS (BETWEEN 30MHZ – 1GHZ)	24
3.2.8 TEST RESULTS (ABOVE 1000 MHZ)	26
4 . MAXIMUM CONDUCTED OUTPUT POWER	32
4.1 APPLIED PROCEDURES / LIMIT	32
4.2 TEST PROCEDURE	32
4.3 DEVIATION FROM STANDARD	32

DongGuan Precise Testing Service Co., Ltd.

Building D, Baoding Technology Park, Guangming Road 2, Guangming Community, Dongcheng District, Dongguan, Guangdong, China

Tel: 86-769-23368601

Fax: 86-769-23368602

[http:// www.pts-testing.com](http://www.pts-testing.com)

Table of Contents		Page
4.4 TEST SETUP		32
4.5 EUT OPERATION CONDITIONS		32
4.6 TEST RESULTS		33
5 . POWER SPECTRAL DENSITY TEST		34
5.1 APPLIED PROCEDURES / LIMIT		34
5.2 TEST PROCEDURE		34
5.3 DEVIATION FROM STANDARD		34
5.4 TEST SETUP		34
5.5 EUT OPERATION CONDITIONS		34
5.6 TEST RESULTS		35
6 . 6DB OCCUPIED BANDWIDTH TEST		43
6.1 APPLIED PROCEDURES / LIMIT		43
6.2 TEST PROCEDURE		43
6.3 DEVIATION FROM STANDARD		43
6.4 TEST SETUP		43
6.5 EUT OPERATION CONDITIONS		43
6.6 TEST RESULTS		44
7 . PEAK EXCURSION TEST		52
7.1 APPLICABLE STANDARD		52
7.2 TEST PROCEDURE		52
7.3 DEVIATION FROM STANDARD		52
7.4 TEST SETUP		52
7.5 EUT OPERATION CONDITIONS		52
7.6 TEST RESULT FOR CONDUCTED SPURIOUS EMISSIONS TEST		53
8 . FREQUENCY STABILITY TEST		61
8.1 APPLICABLE STANDARD		61
8.2 TEST PROCEDURE		61
8.3 DEVIATION FROM STANDARD		61
8.4 TEST SETUP		61
8.5 EUT OPERATION CONDITIONS		61

DongGuan Precise Testing Service Co., Ltd.

Building D, Baoding Technology Park, Guangming Road 2, Guangming Community, Dongcheng
District, Dongguan, Guangdong, China

Tel: 86-769-23368601

Fax: 86-769-23368602

[http:// www.pts-testing.com](http://www.pts-testing.com)

Table of Contents		Page
8.6 TEST RESULT FOR CONDUCTED SPURIOUS EMISSIONS TEST		62
9 . ANTENNA REQUIREMENT		66
9.1 STANDARD REQUIREMENT		66
9.2 EUT ANTENNA		66
10 . EUT TEST PHOTO		67
APPENDIX-PHOTOGRAPHS OF EUT CONSTRUCTIONAL DETAILS		

DongGuan Precise Testing Service Co., Ltd.

Building D, Baoding Technology Park, Guangming Road 2, Guangming Community, Dongcheng
District, Dongguan, Guangdong, China

Tel: 86-769-23368601

Fax: 86-769-23368602

[http:// www.pts-testing.com](http://www.pts-testing.com)

1. SUMMARY OF TEST RESULTS

Test procedures according to the technical standards:

FCC Part15 (15.407) , Subpart E			
Standard Section	Test Item	Judgment	Remark
§15.407(a)	Maximum Conducted Output Power	Compliant	
§15.407(a)	Power Spectral Density	Compliant	
§15.407(e)	6dB Bandwidth	Compliant	
§15.407(a)	Peak Excursion	Compliant	
§15.407(b)	Radiated Emissions	Compliant	
§15.407(b)	Band edge Emissions	Compliant	
§15.407(g)	Frequency Stability	Note	
§15.207(a)	Line Conducted Emissions	Compliant	
§15.203	Antenna Requirements	Compliant	
§2.1093	RF Exposure	Compliant	

NOTE:

(1) "N/A" denotes test is not applicable in this Test Report

DongGuan Precise Testing Service Co., Ltd.

Building D, Baoding Technology Park, Guangming Road 2, Guangming Community, Dongcheng District, Dongguan, Guangdong, China

Tel: 86-769-23368601

Fax: 86-769-23368602

[http:// www.pts-testing.com](http://www.pts-testing.com)

1.1 TEST FACILITY

FCC Registration No.: 371540, IC Registration No.: 12191A-1

Dongguan Precise Testing Service Co., Ltd.

Add.: Building D, Baoding Technology Park, Guangming Road 2, Dongcheng District, Dongguan, Guangdong, China

1.2 MEASUREMENT UNCERTAINTY

The reported uncertainty of measurement $y \pm U$, where expanded uncertainty U is based on a standard uncertainty multiplied by a coverage factor of $k=2$, providing a level of confidence of approximately **95 %**.

No.	Item	Uncertainty
1	Conducted Emission Test	$\pm 1.38\text{dB}$
2	RF power, conducted	$\pm 0.16\text{dB}$
3	Spurious emissions, conducted	$\pm 0.21\text{dB}$
4	All emissions, radiated (<1G)	$\pm 4.68\text{dB}$
5	All emissions, radiated (>1G)	$\pm 4.89\text{dB}$
6	Temperature	$\pm 0.5^\circ\text{C}$
7	Humidity	$\pm 2\%$

DongGuan Precise Testing Service Co., Ltd.

Building D, Baoding Technology Park, Guangming Road 2, Guangming Community, Dongcheng District, Dongguan, Guangdong, China

Tel: 86-769-23368601

Fax: 86-769-23368602

[http:// www.pts-testing.com](http://www.pts-testing.com)

2. GENERAL INFORMATION

2.1 GENERAL DESCRIPTION OF EUT

Equipment	Wireless USB Adapter	
Trade Name	N/A	
Model Name	GWF-5B06	
Product Description	The EUT is a Wireless USB Adapter	
	Operation Frequency:	5725~5850MHz
	Modulation Type:	802.11n: OFDM (64QAM, 16QAM,QPSK,BPSK) 802.11a: OFDM (64QAM, 16QAM,QPSK,BPSK) 802.11ac: OFDM (64QAM, 16QAM,QPSK,BPSK)
	Bit Rate of Transmitter:	802.11n-HT20: 6.5-65 Mbps 802.11n-HT40:13.5-135 Mbps 802.11a: 6-54Mbps 802.11ac: MCS0~MCS9
	Number Of Channel:	For 20MHz bandwidth: 5 Channels For 40MHz bandwidth: 2 Channels For 80MHz bandwidth: 1 Channels
	Antenna Designation:	Please see Note 3.
	Antenna Gain (dBi)	2.8 dBi
	Based on the application, features, or specification exhibited in User's Manual, the EUT is considered as an ITE/Computing Device. More details of EUT technical specification, please refer to the User's Manual.	
Channel List:	Please refer to the Note 2.	
Power supply:	DC 5.0V, 210+/-30mA	
Connecting I/O Port(s)	Please refer to the User's Manual	

Note:

DongGuan Precise Testing Service Co., Ltd.

Building D, Baoding Technology Park, Guangming Road 2, Guangming Community, Dongcheng District, Dongguan, Guangdong, China

Tel: 86-769-23368601

Fax: 86-769-23368602

[http:// www.pts-testing.com](http://www.pts-testing.com)

1. For a more detailed features description, please refer to the manufacturer's specifications or the User's Manual.

2.

Channel List for 802.11n(HT20)/802.11a/802.11ac(20MHz)							
Channel	Frequency (MHz)	Channel	Frequency (MHz)	Channel	Frequency (MHz)	Channel	Frequency (MHz)
149	5745	153	5765	157	5785	161	5805
165	5825						

Channel List for 802.11n(HT40)/802.11ac(40MHz)							
Channel	Frequency (MHz)	Channel	Frequency (MHz)	Channel	Frequency (MHz)	Channel	Frequency (MHz)
151	5755	159	5795	--	--	--	--

Channel List for /802.11ac(80MHz)							
Channel	Frequency (MHz)	Channel	Frequency (MHz)	Channel	Frequency (MHz)	Channel	Frequency (MHz)
155	5775	--	--	--	--	--	--

3.

Table for Filed Antenna

Ant.	Brand	Model Name	Antenna Type	Connector	Gain (dBi)	NOTE
A	N/A	N/A	PCB Antenna	N/A	2.8	Wifi Antenna

2.2 DESCRIPTION OF TEST MODES

To investigate the maximum EMI emission characteristics generates from EUT, the test system was pre-scanning tested base on the consideration of following EUT operation mode or test configuration mode which possible have effect on EMI emission level. Each of these EUT operation mode(s) or test configuration mode(s) mentioned above was evaluated respectively.

Pretest Mode	Description
Mode 1	802.11n-HT20 CH149/ CH157/ CH165
Mode 2	802.11-HT40 CH151/ CH159
Mode 3	802.11a CH149/ CH157/ CH165
Mode 4	802.11ac(20MHz) CH149/ CH157/ CH165
Mode 5	802.11ac(40MHz) CH151/ CH159
Mode 6	802.11ac(80MHz) CH155
Mode 7	Link Mode

For Conducted Emission	
Final Test Mode	Description
Mode 7	Link Mode

For Radiated Emission	
Final Test Mode	Description
Mode 1	802.11n-HT20 CH149/ CH157/ CH165
Mode 2	802.11-HT40 CH151/ CH159
Mode 3	802.11a CH149/ CH157/ CH165
Mode 4	802.11ac(20MHz) CH149/ CH157/ CH165
Mode 5	802.11ac(40MHz) CH151/ CH159
Mode 6	802.11ac(80MHz) CH155
Mode 7	Link Mode

Note:

- (1) The measurements are performed at the highest, middle, lowest available channels.
- (2) The measurements are performed at all Bit Rate of Transmitter, the worst data was reported

2.3 BLOCK DIGRAM SHOWING THE CONFIGURATION OF SYSTEM TESTED

Conducted Emission Test

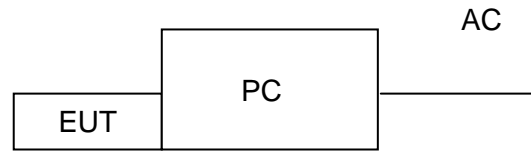

Radiated Spurious Emission Test

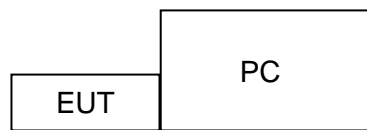

2.4 DESCRIPTION OF SUPPORT UNITS(CONDUCTED MODE)

The EUT has been tested as an independent unit together with other necessary accessories or support units. The following support units or accessories were used to form a representative test configuration during the tests.

Item	Equipment	Mfr/Brand	Model/Type No.	Series No.	Note
PC	PC	Sony	GWF-5B06	N/A	
EUT	Wireless USB Adapter	N/A	GWF-5B06	N/A	

Item	Shielded Type	Ferrite Core	Length	Note

Note:

- (1) The support equipment was authorized by Declaration of Confirmation.
- (2) For detachable type I/O cable should be specified the length in cm in 『Length』 column.

2.5 EQUIPMENTS LIST FOR ALL TEST ITEMS

FOR RADIATED EMISSION TEST (BELOW 1GHZ)

Name of Equipment	Manufacturer	Model	Serial No.	Last Cal.	Next Cal.
EMI Test Receiver	Rohde & Schwarz	ESCI	101417	July 4, 2015	July 3, 2016
Trilog Broadband Antenna (25M-1GHz)	SCHWARZBECK	VULB9160	9160-3355	July 4, 2015	July 3, 2016
Signal Amplifier	SCHWARZBECK	BBV 9475	9745-0013	July 4, 2015	July 3, 2016
RF Cable	SCHWARZBECK	AK9515E	96221	July 4, 2015	July 3, 2016
3m Anechoic Chamber	CHENGYU	966	PTS-001	June 6, 2015	June 5, 2016
MULTI-DEVICE Positioning Controller	Max-Full	MF-7802	MF780208339	N/A	N/A
Active loop antenna (9K-30MHz)	Schwarzbeck	FMZB1519	1519-038	June 6, 2015	June 5, 2016
Spectrum analyzer	Agilent	E4407B	MY46185649	June 6, 2015	June 5, 2016

FOR RADIATED EMISSION TEST (1GHZ ABOVE)

Name of Equipment	Manufacturer	Model	Serial No.	Last Cal.	Next Cal.
EMI Test Receiver	Rohde & Schwarz	ESCI	101417	July 4, 2015	July 3, 2016
Horn Antenna (1G-18GHz)	SCHWARZBECK	BBHA9120D	9120D-1246	July 11, 2015	July 10, 2016
Spectrum Analyzer	Agilent	E4411B	MY4511453	July 4, 2015	July 3, 2016
Signal Amplifier	SCHWARZBECK	BBV 9718	9718-269	July 7, 2015	July 6, 2016
RF Cable	SCHWARZBECK	AK9515H	96220	July 8, 2015	July 7, 2016
3m Anechoic Chamber	CHENGYU	966	PTS-001	June 6, 2015	June 5, 2016
MULTI-DEVICE Positioning Controller	Max-Full	MF-7802	MF780208339	N/A	N/A

DongGuan Precise Testing Service Co., Ltd.

Building D, Baoding Technology Park, Guangming Road 2, Guangming Community, Dongcheng District, Dongguan, Guangdong, China

Tel: 86-769-23368601

Fax: 86-769-23368602

[http:// www.pts-testing.com](http://www.pts-testing.com)

Horn Ant (18G-40GHz)	Schwarzbeck	BBHA 9170	9170-181	June 6, 2015	June 5, 2016
-------------------------	-------------	-----------	----------	--------------	--------------

- Note:** 1. The calibration interval of the above test instruments is 12 months and the calibrations are traceable to CEPREI/CHINA and NIM/CHINA
 2. N/A = No Calibration Request.

FOR CONDUCTED EMISSION TEST:

Name of Equipment	Manufacturer	Model	Serial No.	Last Cal.	Next Cal.
EMI Test Receiver	Rohde & Schwarz	ESCI	101417	July 4, 2015	July 3, 2016
Signal analyzer	Agilent	N9020A	MY51550378	July 8, 2015	July 7, 2016
Artificial Mains Network	Narda	L2-16B	000WX31025	July 8, 2015	July 7, 2016
Artificial Mains Network (AUX)	Narda	L2-16B	000WX31026	July 8, 2015	July 7, 2016
RF Cable	SCHWARZBECK	AK9515E	96222	July 4, 2015	July 3, 2016
Shielded Room	CHENGYU	843	PTS-002	June 6, 2015	June 5, 2016

- Note:** 1. The calibration interval of the above test instruments is 12 months and the calibrations are traceable to CEPREI/CHINA and NIM/CHINA

DongGuan Precise Testing Service Co., Ltd.

Building D, Baoding Technology Park, Guangming Road 2, Guangming Community, Dongcheng District, Dongguan, Guangdong, China

Tel: 86-769-23368601

Fax: 86-769-23368602

[http:// www.pts-testing.com](http://www.pts-testing.com)

3. EMC EMISSION TEST

3.1 CONDUCTED EMISSION MEASUREMENT

3.1.1 POWER LINE CONDUCTED EMISSION Limits (Frequency Range 150KHz-30MHz)

FREQUENCY (MHz)	Class A (dBuV)		Class B (dBuV)		Standard
	Quasi-peak	Average	Quasi-peak	Average	
0.15 -0.5	79.00	66.00	66 - 56 *	56 - 46 *	CISPR
0.50 -5.0	73.00	60.00	56.00	46.00	CISPR
5.0 -30.0	73.00	60.00	60.00	50.00	CISPR

0.15 -0.5	79.00	66.00	66 - 56 *	56 - 46 *	FCC
0.50 -5.0	73.00	60.00	56.00	46.00	FCC
5.0 -30.0	73.00	60.00	60.00	50.00	FCC

Note:

- (1) The tighter limit applies at the band edges.
- (2) The limit of " * " marked band means the limitation decreases linearly with the logarithm of the frequency in the range.

The following table is the setting of the receiver

Receiver Parameters	Setting
Attenuation	10 dB
Start Frequency	0.15 MHz
Stop Frequency	30 MHz
IF Bandwidth	9 kHz

DongGuan Precise Testing Service Co., Ltd.

Building D, Baoding Technology Park, Guangming Road 2, Guangming Community, Dongcheng District, Dongguan, Guangdong, China

Tel: 86-769-23368601

Fax: 86-769-23368602

http:// www.pts-testing.com

3.1.2 TEST PROCEDURE

- a. The EUT was placed 0.8 meters from the horizontal ground plane with EUT being connected to the power mains through a line impedance stabilization network (LISN). All other support equipments powered from additional LISN(s). The LISN provide 50 Ohm/ 50uH of coupling impedance for the measuring instrument.
- b. Interconnecting cables that hang closer than 40 cm to the ground plane shall be folded back and forth in the center forming a bundle 30 to 40 cm long.
- c. I/O cables that are not connected to a peripheral shall be bundled in the center. The end of the cable may be terminated, if required, using the correct terminating impedance. The overall length shall not exceed 1 m.
- d. LISN at least 80 cm from nearest part of EUT chassis.
- e. For the actual test configuration, please refer to the related Item –EUT Test Photos.

3.1.3 DEVIATION FROM TEST STANDARD

No deviation

3.1.4 TEST SETUP

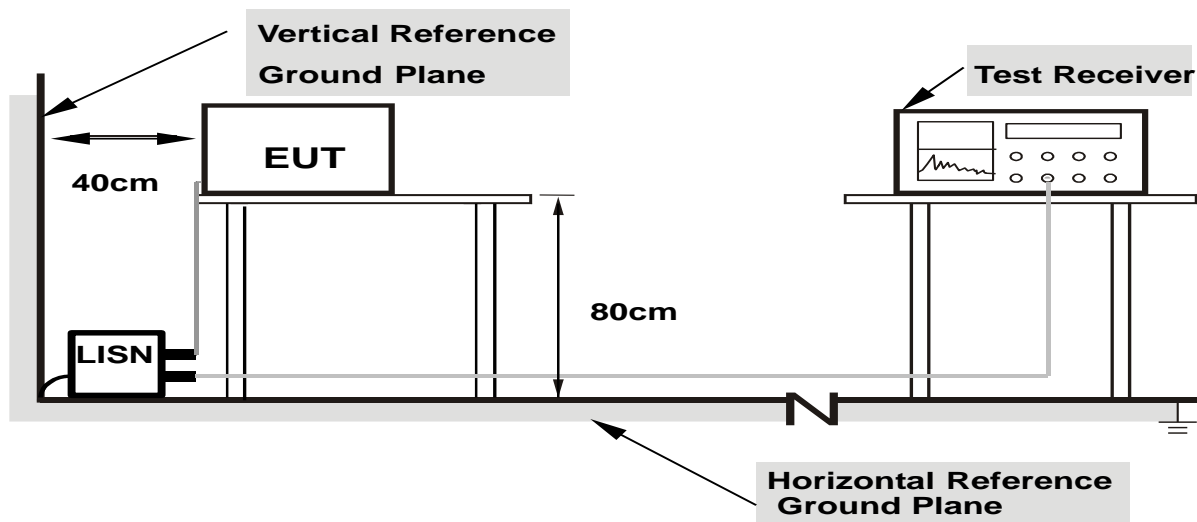

- Note: 1.Support units were connected to second LISN.**
2.Both of LISNs (AMN) are 80 cm from EUT and at least 80 from other units and other metal planes

3.1.5 EUT OPERATING CONDITIONS

The EUT was configured for testing in a typical fashion (as a customer would normally use it). The EUT has been programmed to continuously transmit during test. This operating condition was tested and used to collect the included data.

DongGuan Precise Testing Service Co., Ltd.

Building D, Baoding Technology Park, Guangming Road 2, Guangming Community, Dongcheng District, Dongguan, Guangdong, China

Tel: 86-769-23368601

Fax: 86-769-23368602

[http:// www.pts-testing.com](http://www.pts-testing.com)

3.1.6 TEST RESULTS

EUT :	Wireless USB Adapter	Model Name. :	GWF-5B06
Temperature :	26 °C	Relative Humidity :	54%
Pressure :	1010hPa	Phase :	L
Test Voltage :	AC120V/60Hz	Test Mode :	Mode 7

No.	Freq MHz	Cable Loss dB	AMN Factor dB	Receiver Reading dBuV	Emission Level dBuV	Limit dBuV	Over Limit dB	Remark
1.	0.466	10.64	0.60	28.05	39.29	46.58	-7.29	Average
2.	0.466	10.64	0.60	35.67	46.91	56.58	-9.67	QP
3.	0.585	10.66	0.60	28.02	39.28	46.00	-6.72	Average
4.	0.585	10.66	0.60	36.40	47.66	56.00	-8.34	QP

Remark:

1. All readings are Quasi-Peak and Average values.
2. Factor = Insertion Loss + Cable Loss.

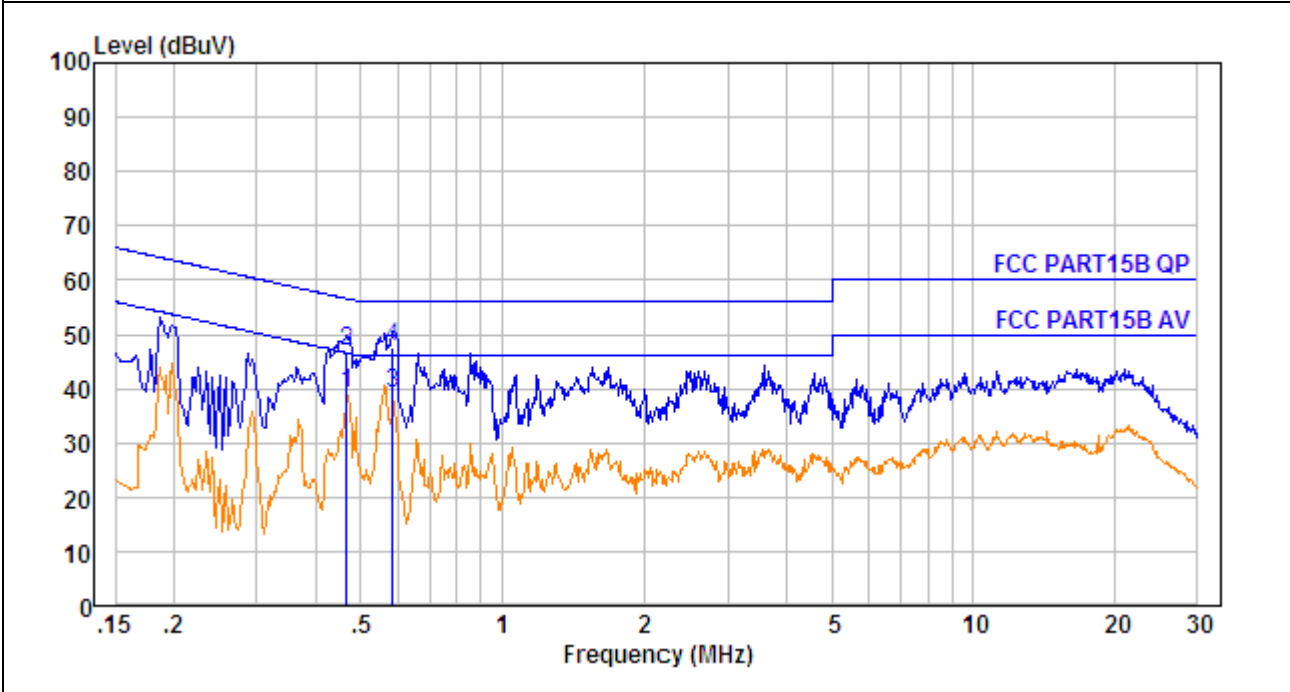

DongGuan Precise Testing Service Co., Ltd.

Building D, Baoding Technology Park, Guangming Road 2, Guangming Community, Dongcheng District, Dongguan, Guangdong, China

Tel: 86-769-23368601

Fax: 86-769-23368602

http:// www.pts-testing.com

EUT :	Wireless USB Adapter	Model Name. :	GWF-5B06
Temperature :	26 °C	Relative Humidity :	54%
Pressure :	1010hPa	Phase :	N
Test Voltage :	AC120V/60Hz	Test Mode :	Mode 7

No.	Freq MHz	Cable Loss dB	AMN Factor dB	Receiver Reading dBuV	Emission Level dBuV	Limit dBuV	Over Limit dB	Remark
1.	0.532	10.65	0.60	10.10	21.35	46.00	-24.65	Average
2.	0.532	10.65	0.60	34.80	46.05	56.00	-9.95	QP
3.	4.158	10.73	0.60	24.93	36.26	46.00	-9.74	Average
4.	4.158	10.73	0.60	36.80	48.13	56.00	-7.87	QP
5.	5.805	10.74	0.60	29.05	40.39	50.00	-9.61	Average
6.	5.805	10.74	0.60	39.86	51.20	60.00	-8.80	QP

Remark:

1. All readings are Quasi-Peak and Average values.
2. Factor = Insertion Loss + Cable Loss.

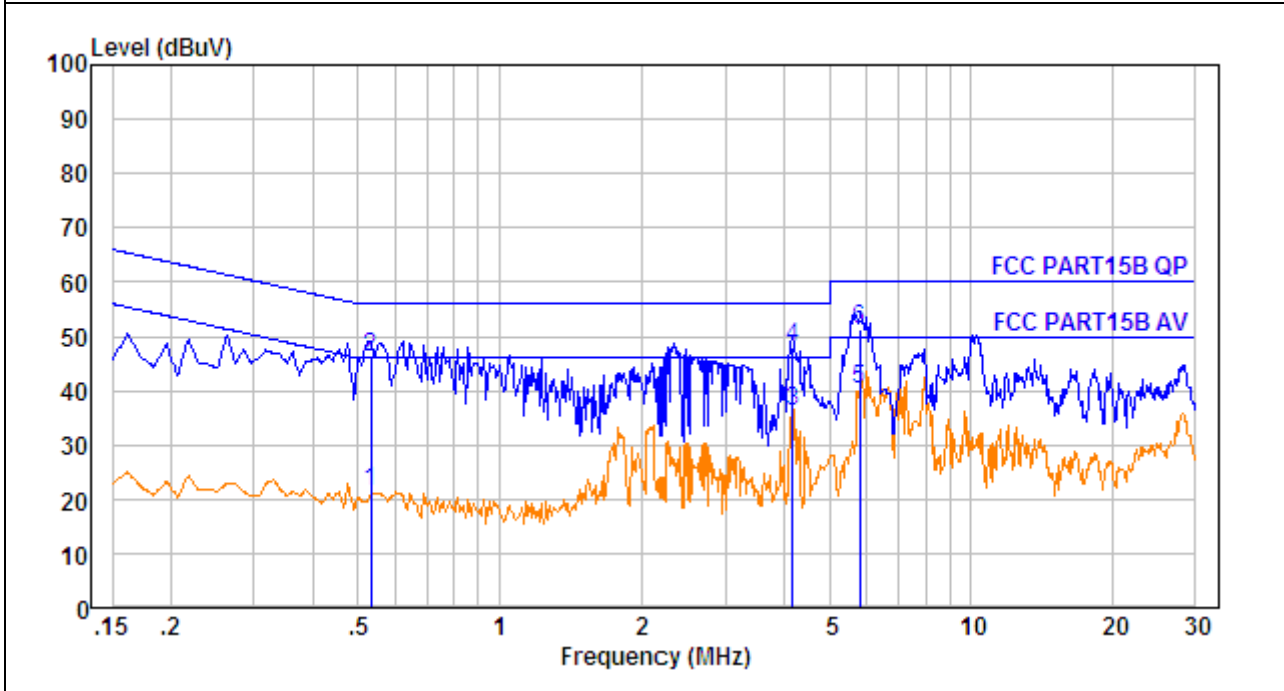

DongGuan Precise Testing Service Co., Ltd.

Building D, Baoding Technology Park, Guangming Road 2, Guangming Community, Dongcheng District, Dongguan, Guangdong, China

Tel: 86-769-23368601

Fax: 86-769-23368602

http:// www.pts-testing.com

3.2 RADIATED EMISSION MEASUREMENT

3.2.1 RADIATED EMISSION LIMITS (Frequency Range 9kHz-1000MHz)

20dBc in any 100 kHz bandwidth outside the operating frequency band. In case the emission fall within the restricted band specified on 15.205(a), then the 15.209(a) limit in the table below has to be followed.

Frequencies (MHz)	Field Strength (micovolts/meter)	Measurement Distance (meters)
0.009~0.490	2400/F(KHz)	300
0.490~1.705	24000/F(KHz)	30
1.705~30.0	30	30
30~88	100	3
88~216	150	3
216~960	200	3
Above 960	500	3

LIMITS OF RADIATED EMISSION MEASUREMENT (Above 1000MHz)

FREQUENCY (MHz)	Class A (dBuV/m) (at 3M)		Class B (dBuV/m) (at 3M)	
	PEAK	AVERAGE	PEAK	AVERAGE
Above 1000	80	60	74	54

Notes:

- (1) The limit for radiated test was performed according to FCC PART 15C.
- (2) The tighter limit applies at the band edges.
- (3) Emission level (dBuV/m)=20log Emission level (uV/m).

Spectrum Parameter	Setting
Attenuation	Auto
Start Frequency	1000 MHz
Stop Frequency	10th carrier harmonic
RB / VB (emission in restricted band)	1 MHz / 1 MHz for Peak, 1 MHz / 10Hz for Average

Receiver Parameter	Setting
Attenuation	Auto
Start ~ Stop Frequency	9kHz~150kHz / RB 200Hz for QP
Start ~ Stop Frequency	150kHz~30MHz / RB 9kHz for QP
Start ~ Stop Frequency	30MHz~1000MHz / RB 120kHz for QP

DongGuan Precise Testing Service Co., Ltd.

Building D, Baoding Technology Park, Guangming Road 2, Guangming Community, Dongcheng District, Dongguan, Guangdong, China

3.2.2 TEST PROCEDURE

- a. The measuring distance of at 3 m shall be used for measurements at frequency up to 1GHz. For frequencies above 1GHz, any suitable measuring distance may be used.
- b. The EUT was placed on the top of a rotating table 0.8 meters above the ground at a 3 meter open area test site. The table was rotated 360 degrees to determine the position of the highest radiation.
- c. The height of the equipment or of the substitution antenna shall be 0.8 m; the height of the test antenna shall vary between 1 m to 4 m. Both horizontal and vertical polarizations of the antenna are set to make the measurement.
- d. The initial step in collecting conducted emission data is a spectrum analyzer peak detector mode pre-scanning the measurement frequency range. Significant peaks are then marked and then Quasi Peak detector mode re-measured.
- e. If the Peak Mode measured value compliance with and lower than Quasi Peak Mode Limit, the EUT shall be deemed to meet QP Limits and then no additional QP Mode measurement performed.
- f. For the actual test configuration, please refer to the related Item –EUT Test Photos.

Note:

Both horizontal and vertical antenna polarities were tested and performed pretest to three orthogonal axis. The worst case emissions were reported

3.2.3 DEVIATION FROM TEST STANDARD

No deviation

3.2.4 TEST SETUP

(A) Radiated Emission Test-Up Frequency Below 30MHz

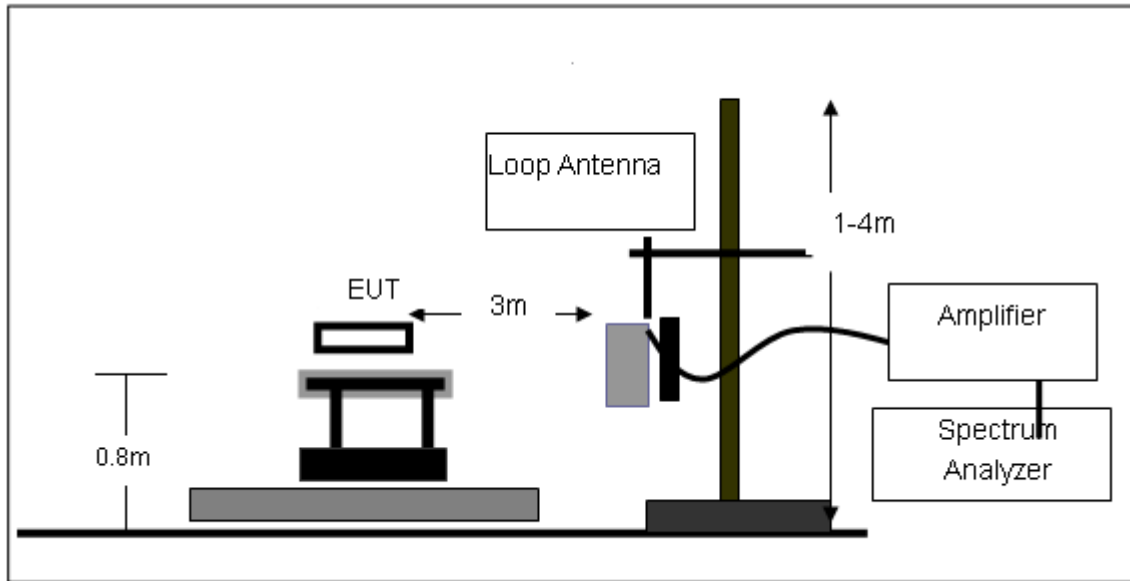

(B) Radiated Emission Test-Up Frequency 30MHz~1GHz

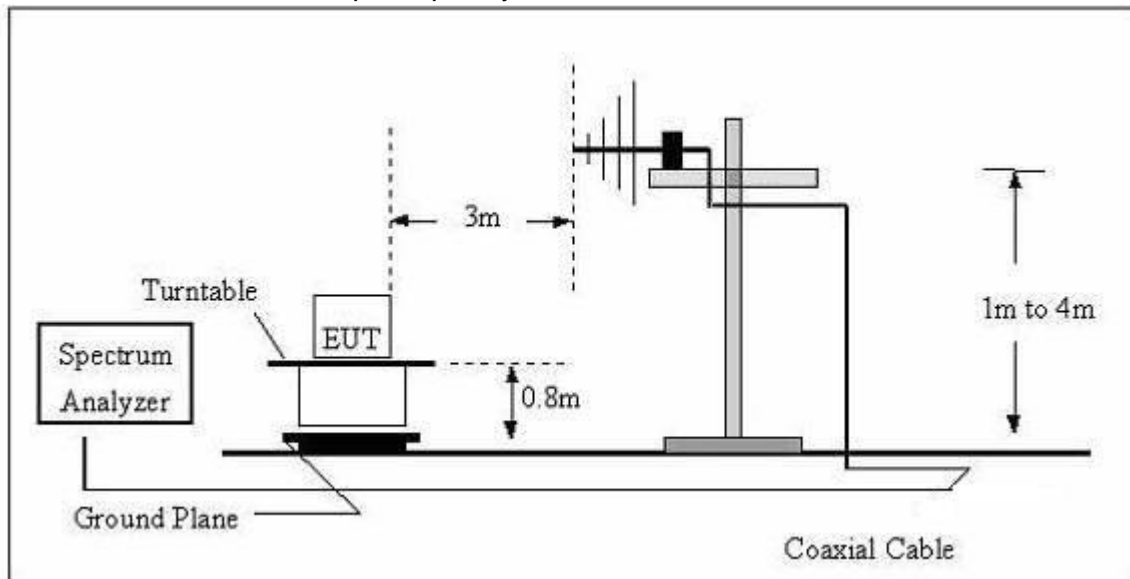

(C) Radiated Emission Test-Up Frequency Above 1GHz

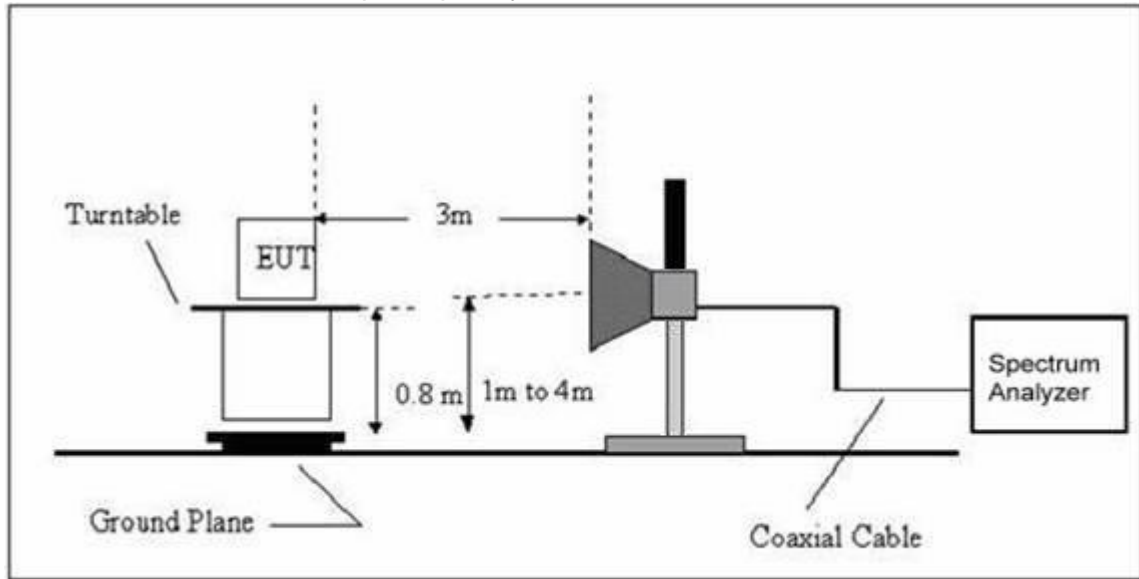

3.2.5 EUT OPERATING CONDITIONS

The EUT tested system was configured as the statements of 2.4 Unless otherwise a special operating condition is specified in the follows during the testing.

3.2.6 TEST RESULTS (BETWEEN 9KHZ – 30 MHZ)

EUT:	Wireless USB Adapter	Model Name. :	GWF-5B06
Temperature:	20 °C	Relative Humidity:	48%
Pressure:	1010 hPa	Test Voltage :	DC 5V
Test Mode :	TX	Polarization :	--

Freq.	Reading	Limit	Margin	State
(MHz)	(dBuV/m)	(dBuV/m)	(dB)	P/F
--	--	--	--	PASS
--	--	--	--	PASS

NOTE:

The amplitude of spurious emissions which are attenuated by more than 20dB below the permissible value has no need to be reported.

Distance extrapolation factor = $40 \log(\text{specific distance/test distance})(\text{dB})$;

Limit line = specific limits(dBuv) + distance extrapolation factor.

3.2.7 TEST RESULTS (BETWEEN 30MHZ – 1GHZ)

EUT :	Wireless USB Adapter	Model Name :	GWF-5B06
Temperature :	20 °C	Relative Humidity :	48%
Pressure:	1010 hPa	Test Voltage :	DC 5V
Test Mode :	Mode 1		

Test plot for Horizontal:

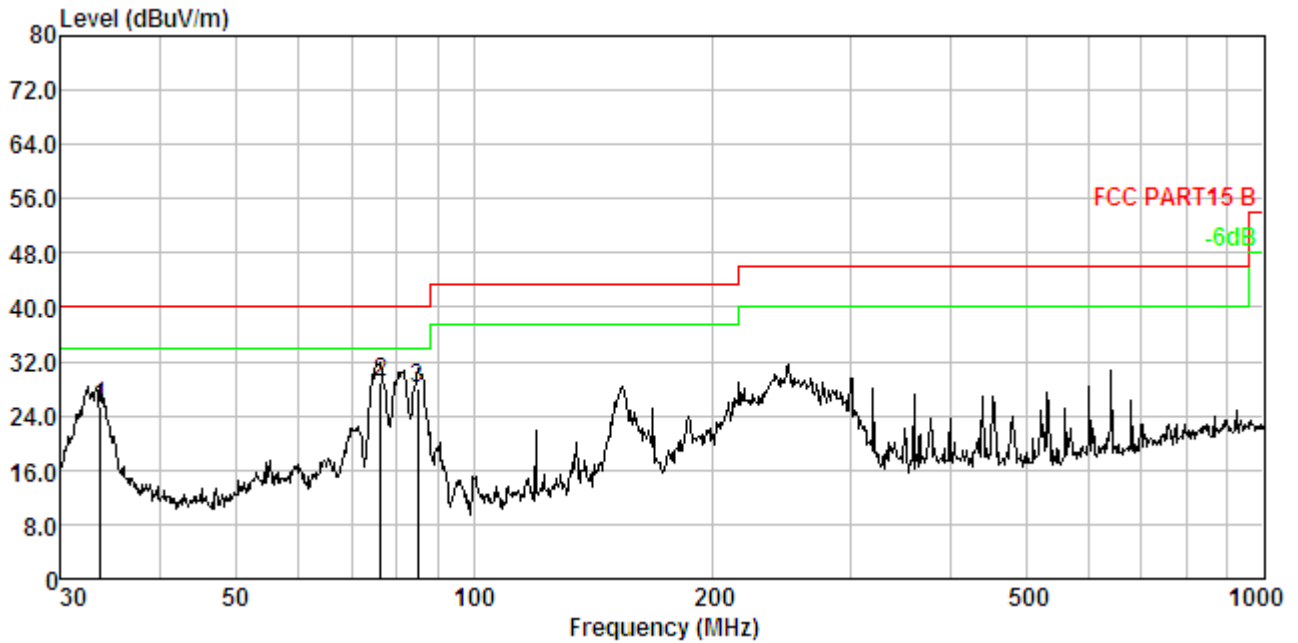

No.	Freq MHz	Cable Loss dB	ANT Factor dB/m	Receiver Reading dBuV	Preamp Factor dB	Emission Level dBuV/m	Limit dBuV/m	Over Limit dB	Remark
1.	33.680	1.16	13.31	41.05	30.01	25.51	40.00	-14.49	QP
2.	76.244	1.90	9.59	47.77	30.29	28.97	40.00	-11.03	QP
3.	84.999	2.00	8.68	47.74	30.33	28.09	40.00	-11.91	QP

Remark:

Absolute Level= ReadingLevel+ Factor, Margin= Limit- Absolute Level

Test plot for Vertical:

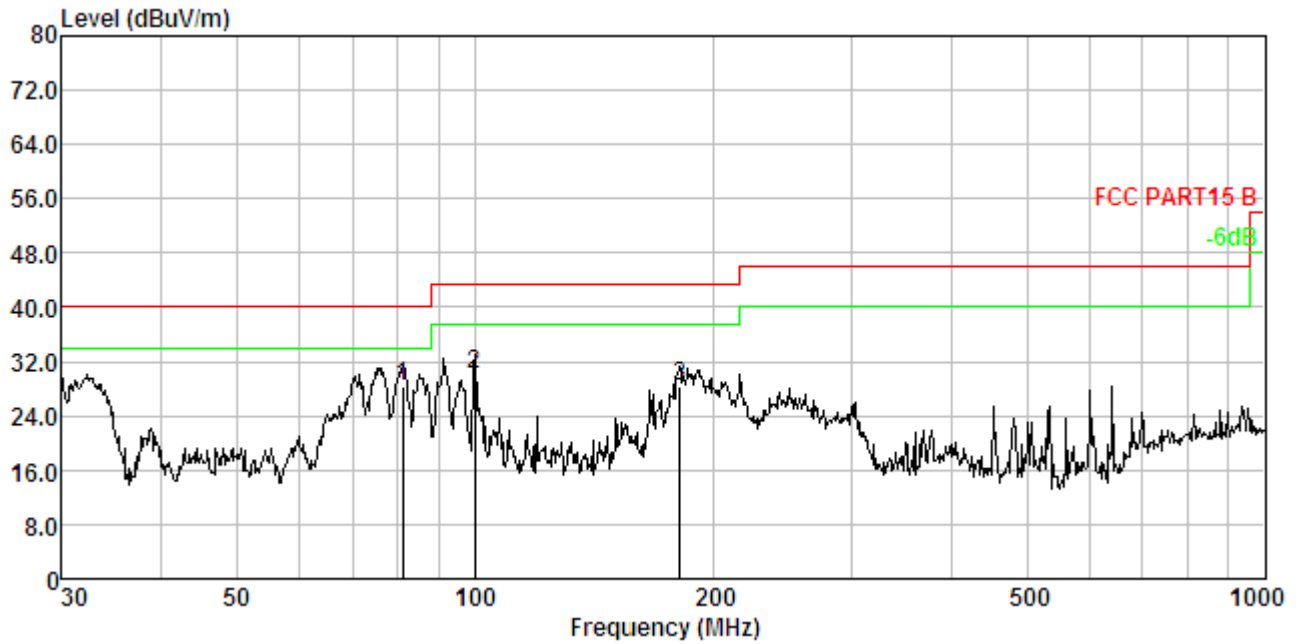

No.	Freq MHz	Cable Loss dB	ANT Factor dB/m	Receiver Reading dBuV	Preamp Factor dB	Emission Level dBuV/m	Limit dBuV/m	Over Limit dB	Remark
1.	81.212	1.96	8.75	47.93	30.32	28.32	40.00	-11.68	QP
2.	100.229	2.15	10.26	47.98	30.39	30.00	43.50	-13.50	QP
3.	181.283	2.68	12.26	44.04	30.60	28.38	43.50	-15.12	QP

Remark:

Absolute Level= ReadingLevel+ Factor, Margin= Limit- Absolute Level

3.2.8 TEST RESULTS (ABOVE 1000 MHZ)

802.11a

Normal Voltage

Polar (H/V)	Frequency	Meter Reading	Factor	Emission Level	Limits	Margin	Detector Type
	(GHz)	(dBuV)	(dB)	(dBuV/m)	(dBuV/m)	(dB)	
operation frequency:5745							
V	17.24	59.69	-3.76	55.93	74.00	-18.07	Pk
V	17.24	42.02	-3.76	38.26	54.00	-15.74	AV
H	17.24	60.21	-3.76	56.45	74.00	-17.55	Pk
H	17.24	44.63	-3.76	40.87	54.00	-13.13	AV
Remark:							
Absolute Level= ReadingLevel+ Factor, Margin= Limit- Absolute Level							

802.11a

Normal Voltage

Polar (H/V)	Frequency	Meter Reading	Factor	Emission Level	Limits	Margin	Detector Type
	(GHz)	(dBuV)	(dB)	(dBuV/m)	(dBuV/m)	(dB)	
operation frequency:5785							
V	17.34	59.02	-3.74	55.28	74.00	-18.72	Pk
V	17.34	42.53	-3.74	38.79	54.00	-15.21	AV
H	17.34	60.30	-3.74	56.56	74.00	-17.44	Pk
H	17.34	43.98	-3.74	40.24	54.00	-13.76	AV
Remark:							
Absolute Level= ReadingLevel+ Factor, Margin= Limit- Absolute Level							

802.11a

Normal Voltage

Polar (H/V)	Frequency	Meter Reading	Factor	Emission Level	Limits	Margin	Detector Type
	(GHz)	(dBuV)	(dB)	(dBuV/m)	(dBuV/m)	(dB)	
operation frequency:5825							
V	17.45	58.89	-3.78	55.11	74.00	-18.89	Pk
V	17.45	42.13	-3.78	38.35	54.00	-15.65	AV
H	17.45	60.47	-3.78	56.69	74.00	-17.31	Pk
H	17.45	44.41	-3.78	40.63	54.00	-13.37	AV
Remark:							
Absolute Level= ReadingLevel+ Factor, Margin= Limit- Absolute Level							

DongGuan Precise Testing Service Co., Ltd.

Building D, Baoding Technology Park, Guangming Road 2, Guangming Community, Dongcheng District, Dongguan, Guangdong, China

802.11n(20MHz)

Normal Voltage

Polar (H/V)	Frequency	Meter Reading	Factor	Emission Level	Limits	Margin	Detector Type
	(GHz)	(dBuV)	(dB)	(dBuV/m)	(dBuV/m)	(dB)	
operation frequency:5745							
V	17.24	59.21	-3.76	55.45	74.00	-18.55	Pk
V	17.24	42.32	-3.76	38.56	54.00	-15.44	AV
H	17.24	60.13	-3.76	56.37	74.00	-17.63	Pk
H	17.24	43.70	-3.76	39.94	54.00	-14.06	AV
Remark:							
Absolute Level= ReadingLevel+ Factor, Margin= Limit- Absolute Level							

802.11n(20MHz)

Normal Voltage

Polar (H/V)	Frequency	Meter Reading	Factor	Emission Level	Limits	Margin	Detector Type
	(GHz)	(dBuV)	(dB)	(dBuV/m)	(dBuV/m)	(dB)	
operation frequency:5785							
V	17.34	59.07	-3.74	55.33	74.00	-18.67	Pk
V	17.34	42.02	-3.74	38.28	54.00	-15.72	AV
H	17.34	60.49	-3.74	56.75	74.00	-17.25	Pk
H	17.34	43.36	-3.74	39.62	54.00	-14.38	AV
Remark:							
Absolute Level= ReadingLevel+ Factor, Margin= Limit- Absolute Level							

802.11n(20MHz)

Normal Voltage

Polar (H/V)	Frequency	Meter Reading	Factor	Emission Level	Limits	Margin	Detector Type
	(GHz)	(dBuV)	(dB)	(dBuV/m)	(dBuV/m)	(dB)	
operation frequency:5825							
V	17.45	59.61	-3.78	55.83	74.00	-18.17	Pk
V	17.45	42.15	-3.78	38.37	54.00	-15.63	AV
H	17.45	60.00	-3.78	56.22	74.00	-17.78	Pk
H	17.45	43.23	-3.78	39.45	54.00	-14.55	AV
Remark:							
Absolute Level= ReadingLevel+ Factor, Margin= Limit- Absolute Level							

802.11n(40MHz)

Normal Voltage

Polar (H/V)	Frequency	Meter Reading	Factor	Emission Level	Limits	Margin	Detector Type
	(GHz)	(dBuV)	(dB)	(dBuV/m)	(dBuV/m)	(dB)	
operation frequency:5755							
V	17.27	57.99	-3.76	54.23	74.00	-19.77	Pk
V	17.27	42.43	-3.76	38.67	54.00	-15.33	AV
H	17.27	59.20	-3.76	55.44	74.00	-18.56	Pk
H	17.27	43.01	-3.76	39.25	54.00	-14.75	AV
Remark:							
Absolute Level= ReadingLevel+ Factor, Margin= Limit- Absolute Level							

802.11n(40MHz)

Normal Voltage

Polar (H/V)	Frequency	Meter Reading	Factor	Emission Level	Limits	Margin	Detector Type
	(GHz)	(dBuV)	(dB)	(dBuV/m)	(dBuV/m)	(dB)	
operation frequency:5795							
V	17.39	58.20	-3.77	54.43	74.00	-19.57	Pk
V	17.39	42.12	-3.77	38.35	54.00	-15.65	AV
H	17.39	59.73	-3.77	55.96	74.00	-18.04	Pk
H	17.39	43.55	-3.77	39.78	54.00	-14.22	AV
Remark:							
Absolute Level= ReadingLevel+ Factor, Margin= Limit- Absolute Level							

802.11ac(20MHz)

Normal Voltage

Polar (H/V)	Frequency	Meter Reading	Factor	Emission Level	Limits	Margin	Detector Type
	(GHz)	(dBuV)	(dB)	(dBuV/m)	(dBuV/m)	(dB)	
operation frequency:5745							
V	17.24	60.40	-3.76	56.64	74.00	-17.36	Pk
V	17.24	43.54	-3.76	39.78	54.00	-14.22	AV
H	17.24	61.00	-3.76	57.24	74.00	-16.76	Pk
H	17.24	44.42	-3.76	40.66	54.00	-13.34	AV
Remark:							
Absolute Level= ReadingLevel+ Factor, Margin= Limit- Absolute Level							

802.11ac(20MHz)

Normal Voltage

Polar (H/V)	Frequency	Meter Reading	Factor	Emission Level	Limits	Margin	Detector Type
	(GHz)	(dBuV)	(dB)	(dBuV/m)	(dBuV/m)	(dB)	
operation frequency:5785							
V	17.34	60.32	-3.74	56.58	74.00	-17.42	Pk
V	17.34	43.01	-3.74	39.27	54.00	-14.73	AV
H	17.34	61.60	-3.74	57.86	74.00	-16.14	Pk
H	17.34	44.26	-3.74	40.52	54.00	-13.48	AV
Remark:							
Absolute Level= ReadingLevel+ Factor, Margin= Limit- Absolute Level							

802.11ac(20MHz)

Normal Voltage

Polar (H/V)	Frequency	Meter Reading	Factor	Emission Level	Limits	Margin	Detector Type
	(GHz)	(dBuV)	(dB)	(dBuV/m)	(dBuV/m)	(dB)	
operation frequency:5825							
V	17.45	60.07	-3.78	56.29	74.00	-17.71	Pk
V	17.45	43.22	-3.78	39.44	54.00	-14.56	AV
H	17.45	61.45	-3.78	57.67	74.00	-16.33	Pk
H	17.45	43.91	-3.78	40.13	54.00	-13.87	AV
Remark:							
Absolute Level= ReadingLevel+ Factor, Margin= Limit- Absolute Level							

802.11ac(40MHz)

Normal Voltage

Polar (H/V)	Frequency	Meter Reading	Factor	Emission Level	Limits	Margin	Detector Type
	(GHz)	(dBuV)	(dB)	(dBuV/m)	(dBuV/m)	(dB)	
operation frequency:5755							
V	17.27	59.00	-3.76	55.24	74.00	-18.76	Pk
V	17.27	42.12	-3.76	38.36	54.00	-15.64	AV
H	17.27	60.65	-3.76	56.89	74.00	-17.11	Pk
H	17.27	43.21	-3.76	39.45	54.00	-14.55	AV
Remark:							
Absolute Level= ReadingLevel+ Factor, Margin= Limit- Absolute Level							

802.11ac(40MHz)

Normal Voltage

Polar (H/V)	Frequency	Meter Reading	Factor	Emission Level	Limits	Margin	Detector Type
	(GHz)	(dBuV)	(dB)	(dBuV/m)	(dBuV/m)	(dB)	
operation frequency:5795							
V	17.39	59.23	-3.77	55.46	74.00	-18.54	Pk
V	17.39	42.60	-3.77	38.83	54.00	-15.17	AV
H	17.39	60.04	-3.77	56.27	74.00	-17.73	Pk
H	17.39	43.65	-3.77	39.88	54.00	-14.12	AV
Remark:							
Absolute Level= ReadingLevel+ Factor, Margin= Limit- Absolute Level							

802.11ac(80MHz)

Normal Voltage

Polar (H/V)	Frequency	Meter Reading	Factor	Emission Level	Limits	Margin	Detector Type
	(GHz)	(dBuV)	(dB)	(dBuV/m)	(dBuV/m)	(dB)	
operation frequency:5775							
V	17.33	58.07	-3.74	54.33	74.00	-19.67	Pk
V	17.33	41.73	-3.74	37.99	54.00	-16.01	AV
H	17.33	59.20	-3.74	55.46	74.00	-18.54	Pk
H	17.33	42.41	-3.74	38.67	54.00	-15.33	AV
Remark:							
Absolute Level= ReadingLevel+ Factor, Margin= Limit- Absolute Level							

DongGuan Precise Testing Service Co., Ltd.

Building D, Baoding Technology Park, Guangming Road 2, Guangming Community, Dongcheng District, Dongguan, Guangdong, China

Results of Band Edges Test:

802.11a

Normal Voltage

Polar (H/V)	Frequency	Meter Reading	Factor	Emission Level	Limits	Margin	Detector Type
	(MHz)	(dBuV)	(dB)	(dBuV/m)	(dBuV/m)	(dB)	
operation frequency:5745							
V	5725.00	53.98	-3.70	50.28	74.00	-23.72	Pk
V	5725.00	39.05	-3.70	35.35	54.00	-18.65	AV
H	5725.00	54.99	-3.70	51.29	74.00	-22.71	Pk
H	5725.00	39.13	-3.70	35.43	54.00	-18.57	AV
Remark:							
Absolute Level= ReadingLevel+ Factor, Margin= Limit- Absolute Level							

802.11a

Normal Voltage

Polar (H/V)	Frequency	Meter Reading	Factor	Emission Level	Limits	Margin	Detector Type
	(MHz)	(dBuV)	(dB)	(dBuV/m)	(dBuV/m)	(dB)	
operation frequency:5825							
V	5850.00	54.04	-3.72	50.32	74.00	-23.68	Pk
V	5850.00	39.16	-3.72	35.44	54.00	-18.56	AV
H	5850.00	55.40	-3.72	51.68	74.00	-22.32	Pk
H	5850.00	38.86	-3.72	35.14	54.00	-18.86	AV
Remark:							
Absolute Level= ReadingLevel+ Factor, Margin= Limit- Absolute Level							

Note: All modes have been tested and we only record the worst result.

4. MAXIMUM CONDUCTED OUTPUT POWER

4.1 APPLIED PROCEDURES / LIMIT

For 5745~5805MHz

For the band 5.725-5.85 GHz, the maximum conducted output power over the frequency band of operation shall not exceed 1 W. In addition, the maximum power spectral density shall not exceed 30 dBm in any 500-kHz band. If transmitting antennas of directional gain greater than 6 dBi are used, both the maximum conducted output power and the maximum power spectral density shall be reduced by the amount in dB that the directional gain of the antenna exceeds 6 dBi. However, fixed point-to-point U-NII devices operating in this band may employ transmitting antennas with directional gain greater than 6 dBi without any corresponding reduction in transmitter conducted power. Fixed, point-to-point operations exclude the use of point-to-multipoint systems, omnidirectional applications, and multiple collocated transmitters transmitting the same information. The operator of the U-NII device, or if the equipment is professionally installed, the installer, is responsible for ensuring that systems employing high gain directional antennas are used exclusively for fixed, point-to-point operations.

4.2 TEST PROCEDURE

The transmitter output (antenna port) was connected to the power sensor. Read the test result from the power meter and record it.

4.3 DEVIATION FROM STANDARD

No deviation.

4.4 TEST SETUP



4.5 EUT OPERATION CONDITIONS

The EUT tested system was configured as the statements of 2.1 Unless otherwise a special operating condition is specified in the follows during the testing.

4.6 TEST RESULTS

EUT :	Wireless USB Adapter	Model Name :	GWF-5B06
Temperature :	25 °C	Relative Humidity :	60%
Pressure :	1015 hPa	Test Voltage :	DC 5V

Test Channel	Frequency	Maximum Conducted Output Power(PK)	Maximum Conducted Output Power(AV)	LIMIT
	(MHz)	(dBm)	(dBm)	dBm
TX 802.11a Mode				
CH149	5745	16.59	13.67	30
CH157	5785	16.78	13.44	30
CH165	5825	17.14	13.90	30
TX 802.11n-HT20 Mode				
CH149	5745	14.65	11.35	30
CH157	5785	14.79	11.77	30
CH165	5825	14.43	11.25	30
TX 802.11n-HT40 Mode				
CH151	5755	13.75	10.19	30
CH159	5795	13.89	10.37	30
TX 802.11ac(20MHz) Mode				
CH149	5745	16.53	13.79	30
CH157	5785	16.32	13.39	30
CH165	5825	16.46	13.75	30
TX 802.11ac(40MHz) Mode				
CH151	5755	13.51	10.34	30
CH159	5795	13.76	10.48	30
TX 802.11ac(80MHz) Mode				
CH155	5775	16.43	13.32	30

DongGuan Precise Testing Service Co., Ltd.

Building D, Baoding Technology Park, Guangming Road 2, Guangming Community, Dongcheng District, Dongguan, Guangdong, China

Tel: 86-769-23368601

Fax: 86-769-23368602

[http:// www.pts-testing.com](http://www.pts-testing.com)

5. POWER SPECTRAL DENSITY TEST

5.1 APPLIED PROCEDURES / LIMIT

The power spectral density is defined as the highest level of power in dBm per MHz generated by the transmitter within the power envelope. The power spectral density limits as show follow.

Frequency range(MHz)	Power Spectral Density Limit
5725~5850	30 dBm/500kHz

5.2 TEST PROCEDURE

1. The transmitter was connected directly to a Spectrum Analyzer through a directional couple.
2. The power was monitored at the coupler port with a Spectrum Analyzer. The power level was set to the maximum level.
3. Set the RBW = 500 kHz.
4. Set the VBW $\geq 3 \times$ RBW
5. Span=Encompass the entire emissions bandwidth (EBW) of the signal
6. Detector = peak.
7. Sweep time = auto couple.
8. Trace mode = max hold.
9. Allow trace to fully stabilize.
10. Use the peak marker function to determine the maximum power level in any 1MHz band segment within the fundamental EBW.

5.3 DEVIATION FROM STANDARD

No deviation.

5.4 TEST SETUP

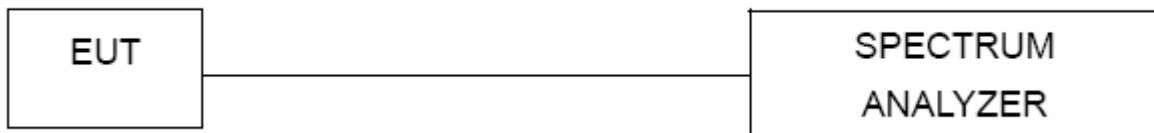

5.5 EUT OPERATION CONDITIONS

The EUT tested system was configured as the statements of 2.4 Unless otherwise a special operating condition is specified in the follows during the testing.

5.6 TEST RESULTS

EUT :	Wireless USB Adapter	Model Name :	GWF-5B06
Temperature :	25 °C	Relative Humidity :	60%
Pressure :	1012 hPa	Test Voltage :	DC 5V

Channel	Frequency (MHz)	Power Density (dBm/MHz)	Duty cycle factor (dB)	10log(500kHz/RBW) Factor (dB)	Sum PSD (dBm/MHz)	Max. Limit (dBm/MHz)	Result
TX 802.11a Mode							
CH149	5745	-5.620	0	2.22	-3.400	30	Complies
CH157	5785	-5.537	0	2.22	-3.317	30	Complies
CH165	5825	-5.276	0	2.22	-3.056	30	Complies
TX 802.11n-HT20 Mode							
CH149	5745	-5.919	0	2.22	-3.699	30	Complies
CH157	5785	-5.697	0	2.22	-3.477	30	Complies
CH165	5825	-5.418	0	2.22	-3.198	30	Complies
TX 802.11n-HT40 Mode							
CH151	5755	-8.156	0	2.22	-5.936	30	Complies
CH159	5795	-7.666	0	2.22	-5.446	30	Complies
TX 802.11ac(20MHz) Mode							
CH149	5745	-5.548	0	2.22	-3.328	30	Complies
CH157	5785	-5.459	0	2.22	-3.239	30	Complies
CH165	5825	-5.249	0	2.22	-3.029	30	Complies
TX 802.11ac(40MHz) Mode							
CH151	5755	-8.634	0	2.22	-6.414	30	Complies
CH159	5795	-8.469	0	2.22	-6.249	30	Complies
TX 802.11ac(80MHz) Mode							
CH155	5775	-11.307	0	2.22	-9.087	30	Complies

Duty cycle factor=10log(Ton/Tperiod)=10log[1/100%]dB =0 dB

DongGuan Precise Testing Service Co., Ltd.

Building D, Baoding Technology Park, Guangming Road 2, Guangming Community, Dongcheng District, Dongguan, Guangdong, China

Tel: 86-769-23368601

Fax: 86-769-23368602

http:// www.pts-testing.com

802.11a mode-ch165

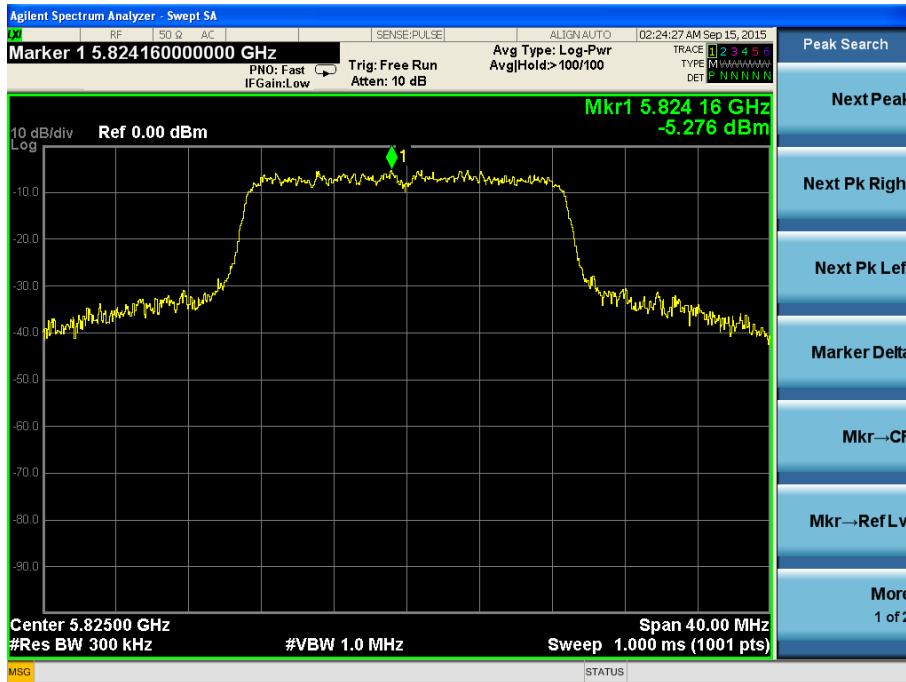

802.11n-HT20 mode-ch149

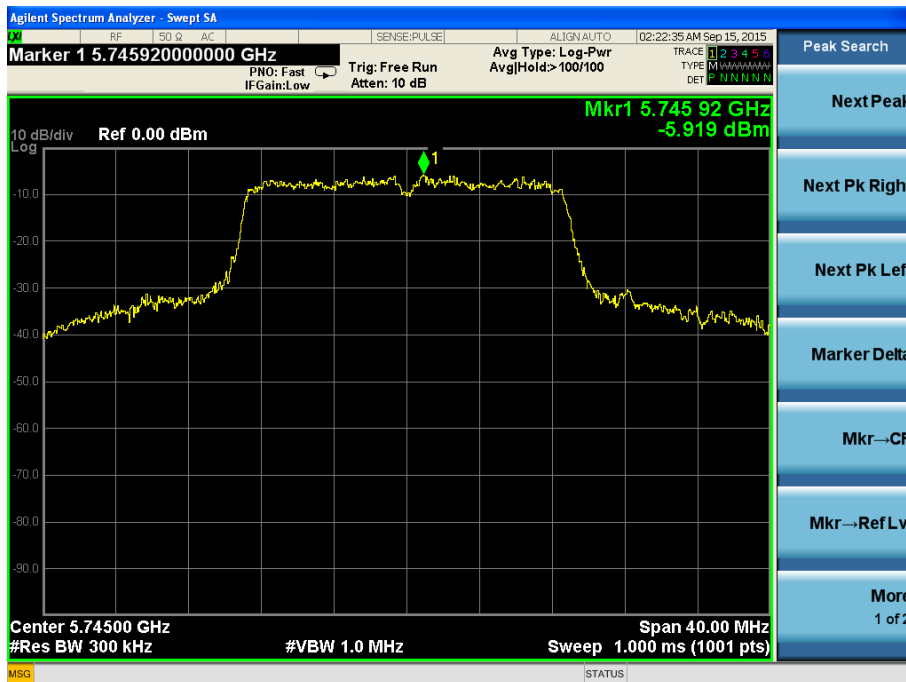

DongGuan Precise Testing Service Co., Ltd.

Building D, Baoding Technology Park, Guangming Road 2, Guangming Community, Dongcheng District, Dongguan, Guangdong, China

Tel: 86-769-23368601

Fax: 86-769-23368602

http:// www.pts-testing.com

802.11n-HT20 mode-ch157

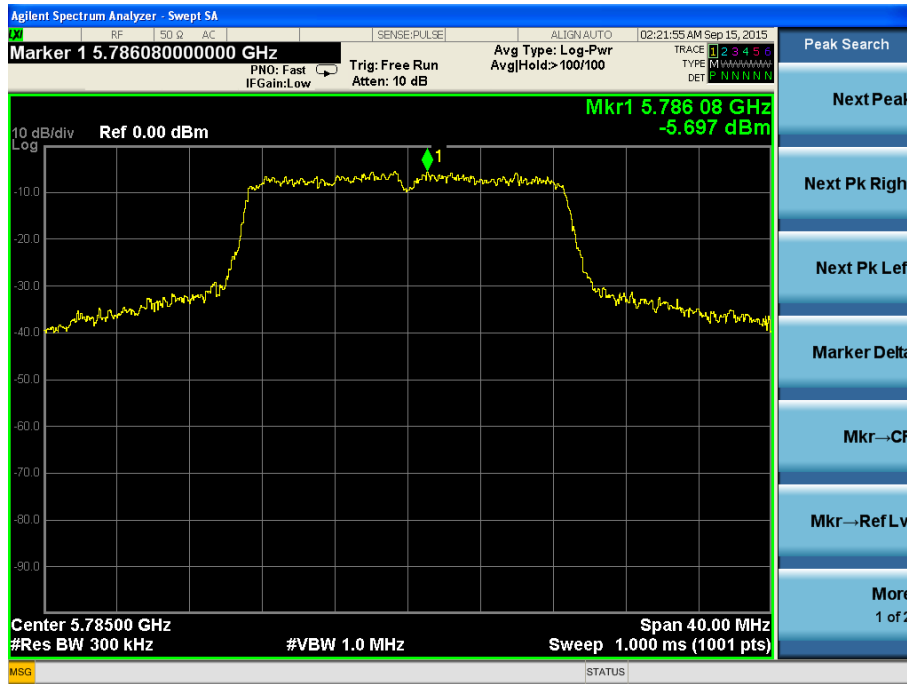

802.11n-HT20 mode-ch165

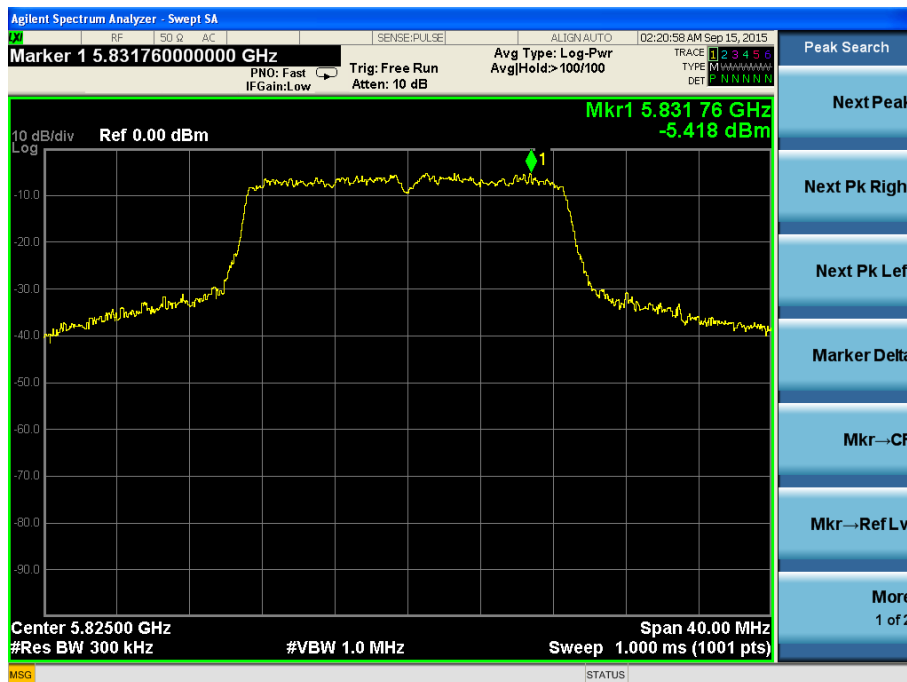

DongGuan Precise Testing Service Co., Ltd.

Building D, Baoding Technology Park, Guangming Road 2, Guangming Community, Dongcheng District, Dongguan, Guangdong, China

Tel: 86-769-23368601

Fax: 86-769-23368602

http:// www.pts-testing.com

802.11n-HT40 mode-ch151

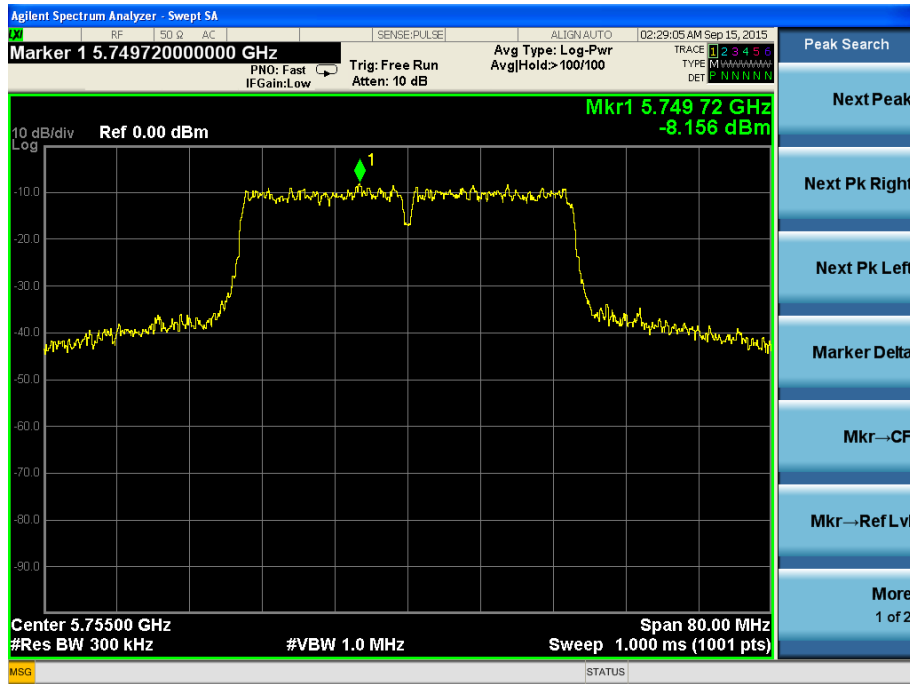

802.11n-HT40 mode-ch159

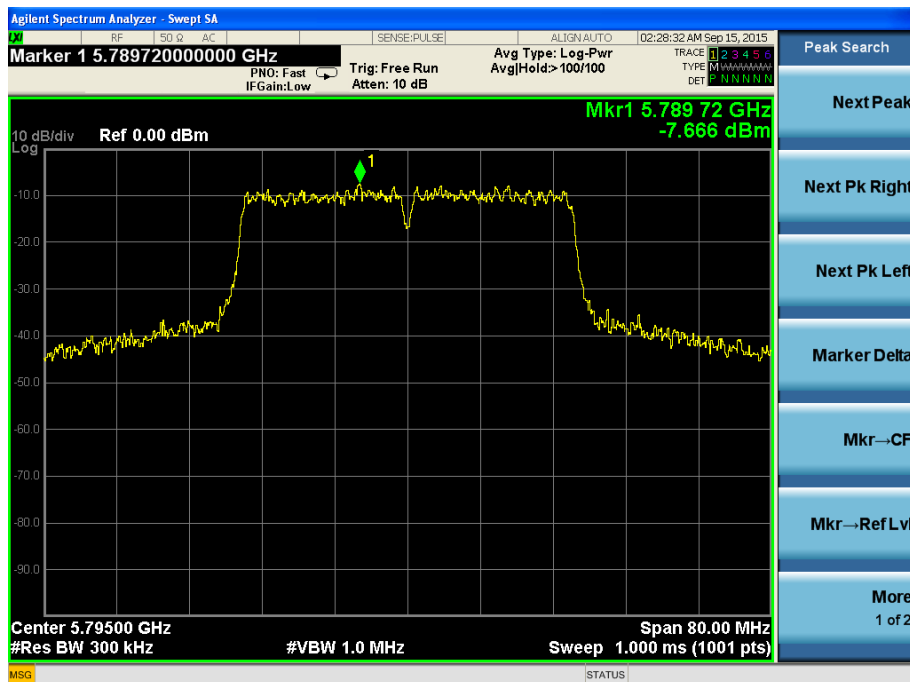

DongGuan Precise Testing Service Co., Ltd.

Building D, Baoding Technology Park, Guangming Road 2, Guangming Community, Dongcheng District, Dongguan, Guangdong, China

Tel: 86-769-23368601

Fax: 86-769-23368602

http:// www.pts-testing.com

802.11ac(20MHz) mode-ch149

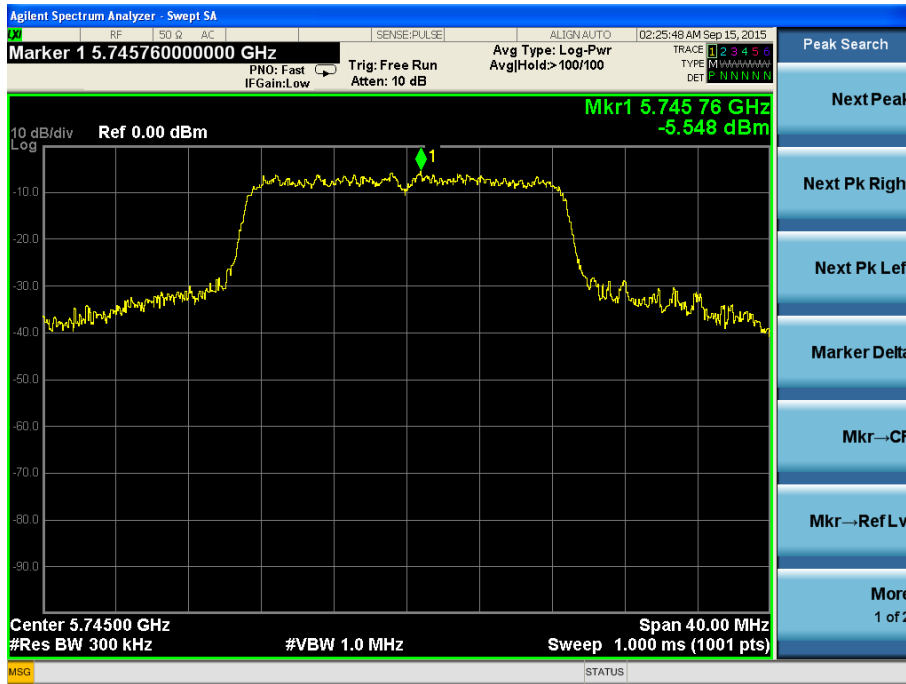

802.11ac(20MHz) mode-ch157

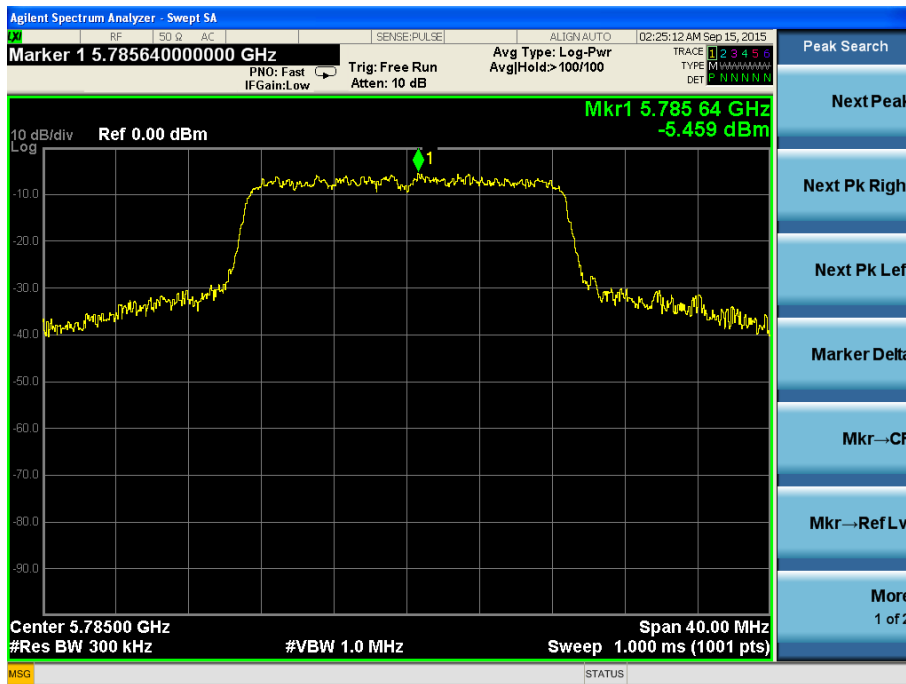

DongGuan Precise Testing Service Co., Ltd.

Building D, Baoding Technology Park, Guangming Road 2, Guangming Community, Dongcheng District, Dongguan, Guangdong, China

Tel: 86-769-23368601

Fax: 86-769-23368602

[http:// www.pts-testing.com](http://www.pts-testing.com)

802.11ac(40MHz) mode-ch159

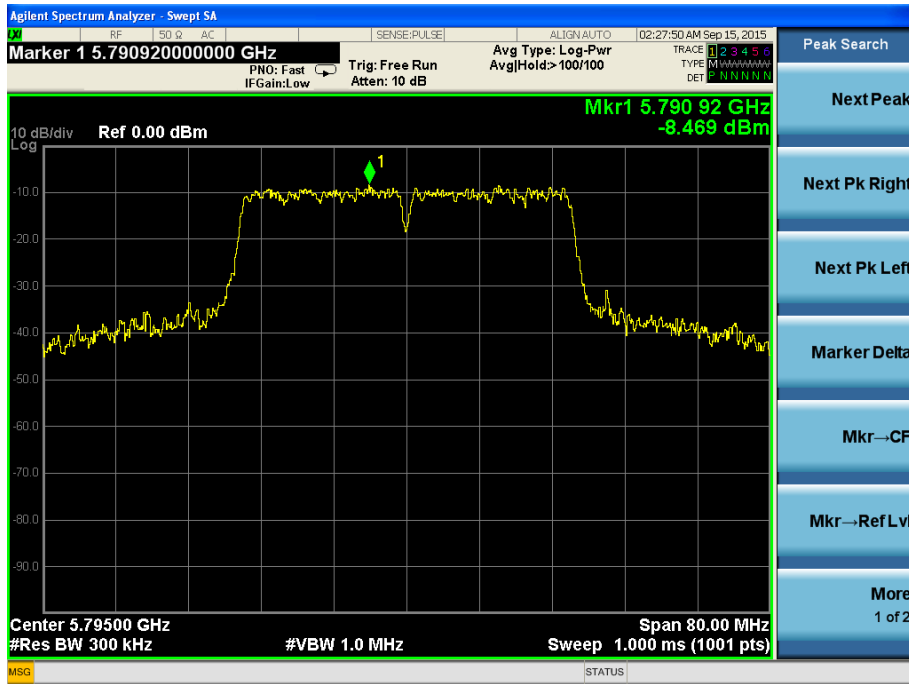

802.11ac(80MHz) mode-ch155

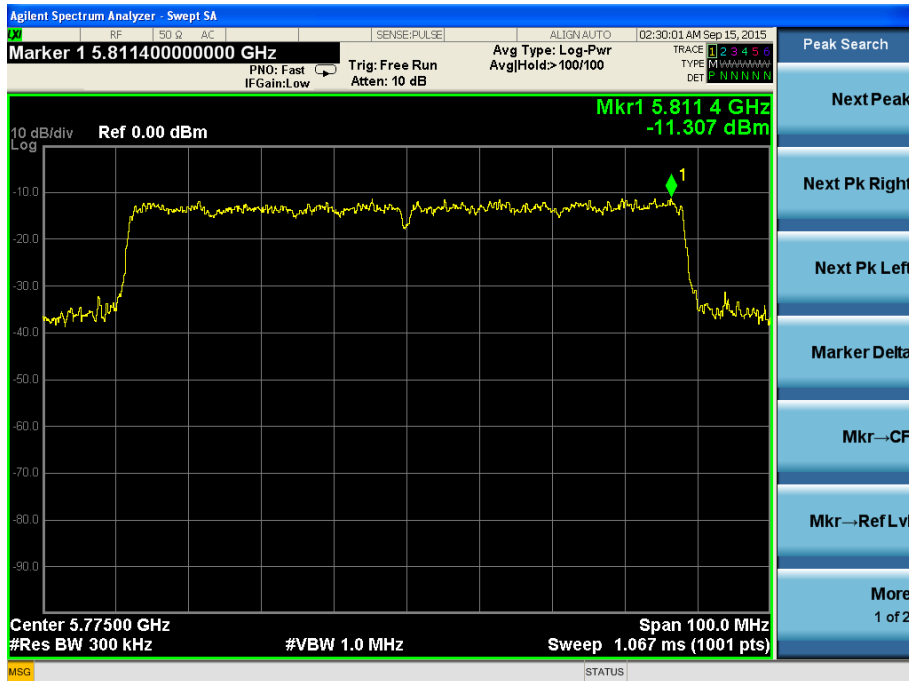

DongGuan Precise Testing Service Co., Ltd.

Building D, Baoding Technology Park, Guangming Road 2, Guangming Community, Dongcheng District, Dongguan, Guangdong, China

Tel: 86-769-23368601

Fax: 86-769-23368602

http:// www.pts-testing.com

6. 6DB OCCUPIED BANDWIDTH TEST

6.1 APPLIED PROCEDURES / LIMIT

Within the 5.725-5.85 GHz band, the minimum 6 dB bandwidth of U-NII devices shall be at least 500 kHz.

6.2 TEST PROCEDURE

1. The transmitter output (antenna port) was connected to the spectrum analyser in peak hold mode.
2. The resolution bandwidth of 100 kHz and the video bandwidth of 300 kHz were used.
3. Measured the spectrum width with power higher than 6dB below carrier.

6.3 DEVIATION FROM STANDARD

No deviation.

6.4 TEST SETUP

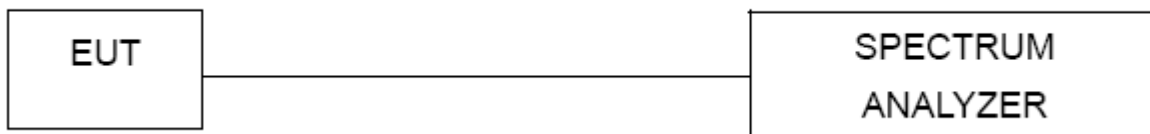

6.5 EUT OPERATION CONDITIONS

The EUT tested system was configured as the statements of 2.4 Unless otherwise a special operating condition is specified in the follows during the testing.

6.6 TEST RESULTS

EUT :	Wireless USB Adapter	Model Name :	GWF-5B06
Temperature :	25 °C	Relative Humidity :	60%
Pressure :	1012 hPa	Test Voltage :	DC 5V

Test Channel	Frequency (MHz)	6dB Bandwidth (MHz)	Limit (MHz)
TX 802.11a Mode			
CH149	5745	17.73	0.5
CH157	5785	17.70	0.5
CH165	5825	17.72	0.5
TX 802.11n-HT20 Mode			
CH149	5745	17.67	0.5
CH157	5785	17.64	0.5
CH165	5825	17.56	0.5
TX 802.11n-HT40 Mode			
CH151	5755	36.51	0.5
CH159	5795	36.52	0.5
TX 802.11ac(20MHz) Mode			
CH149	5745	17.73	0.5
CH157	5785	17.73	0.5
CH165	5825	17.73	0.5
TX 802.11ac(40MHz) Mode			
CH151	5755	36.34	0.5
CH159	5795	36.51	0.5
TX 802.11ac(80MHz) Mode			
CH155	5775	76.50	0.5

DongGuan Precise Testing Service Co., Ltd.

Building D, Baoding Technology Park, Guangming Road 2, Guangming Community, Dongcheng District, Dongguan, Guangdong, China

Tel: 86-769-23368601

Fax: 86-769-23368602

[http:// www.pts-testing.com](http://www.pts-testing.com)

802.11a mode-ch149

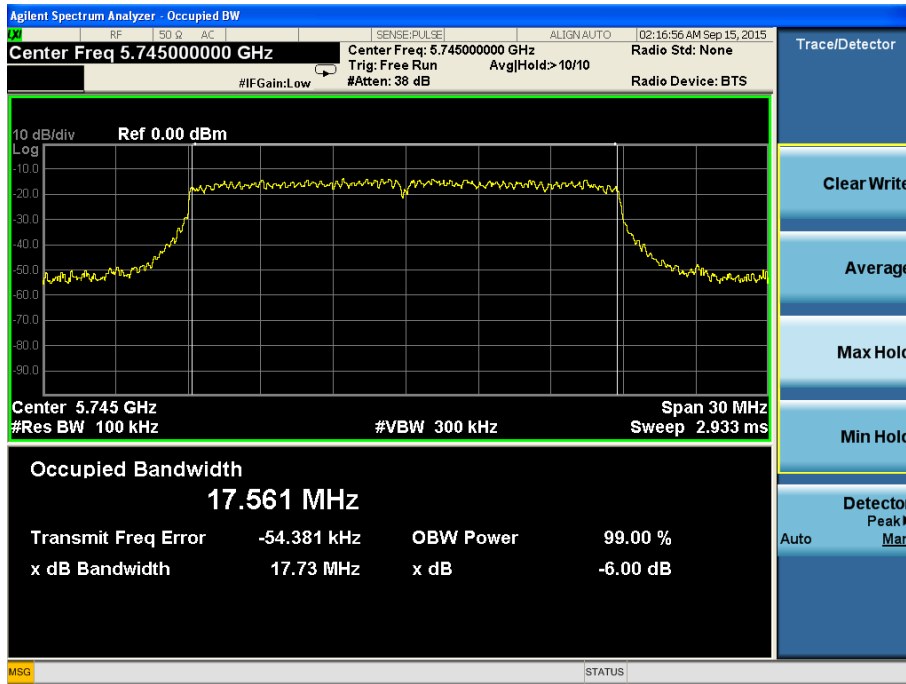

802.11a mode-ch157

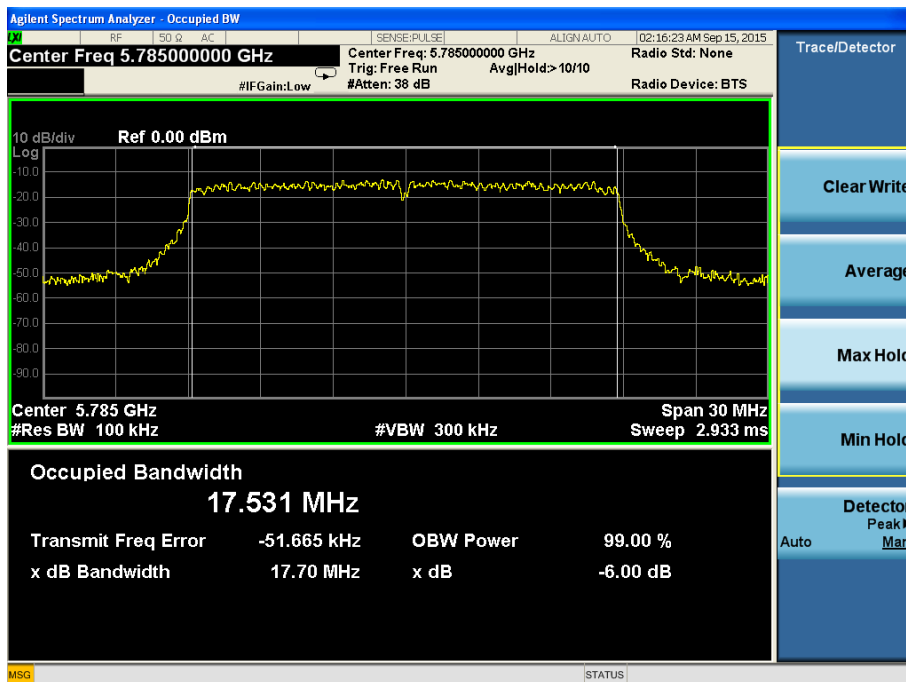

DongGuan Precise Testing Service Co., Ltd.

Building D, Baoding Technology Park, Guangming Road 2, Guangming Community, Dongcheng District, Dongguan, Guangdong, China

Tel: 86-769-23368601

Fax: 86-769-23368602

http:// www.pts-testing.com

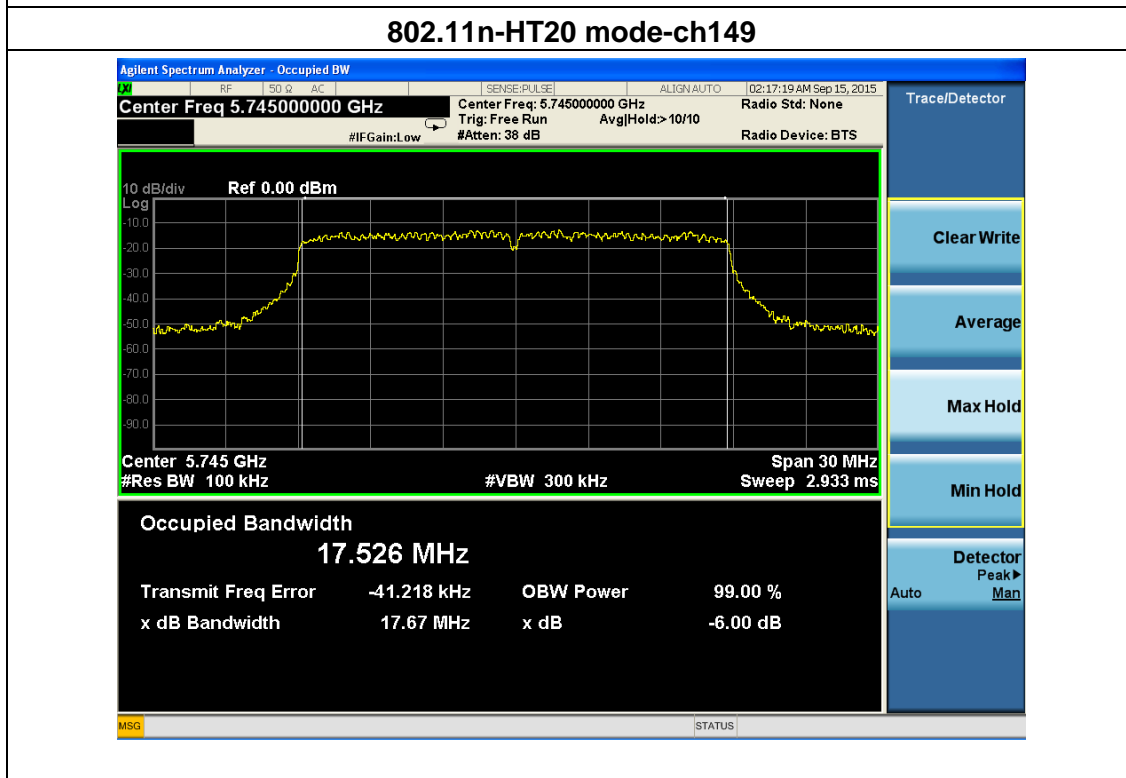
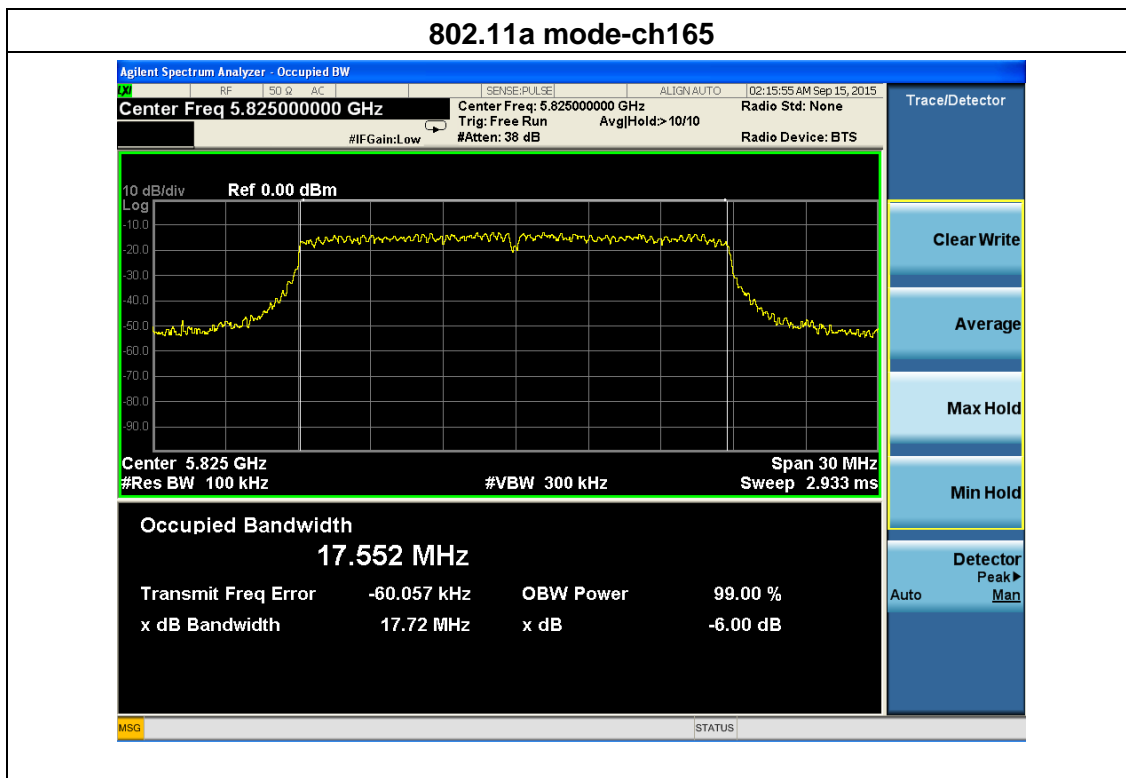

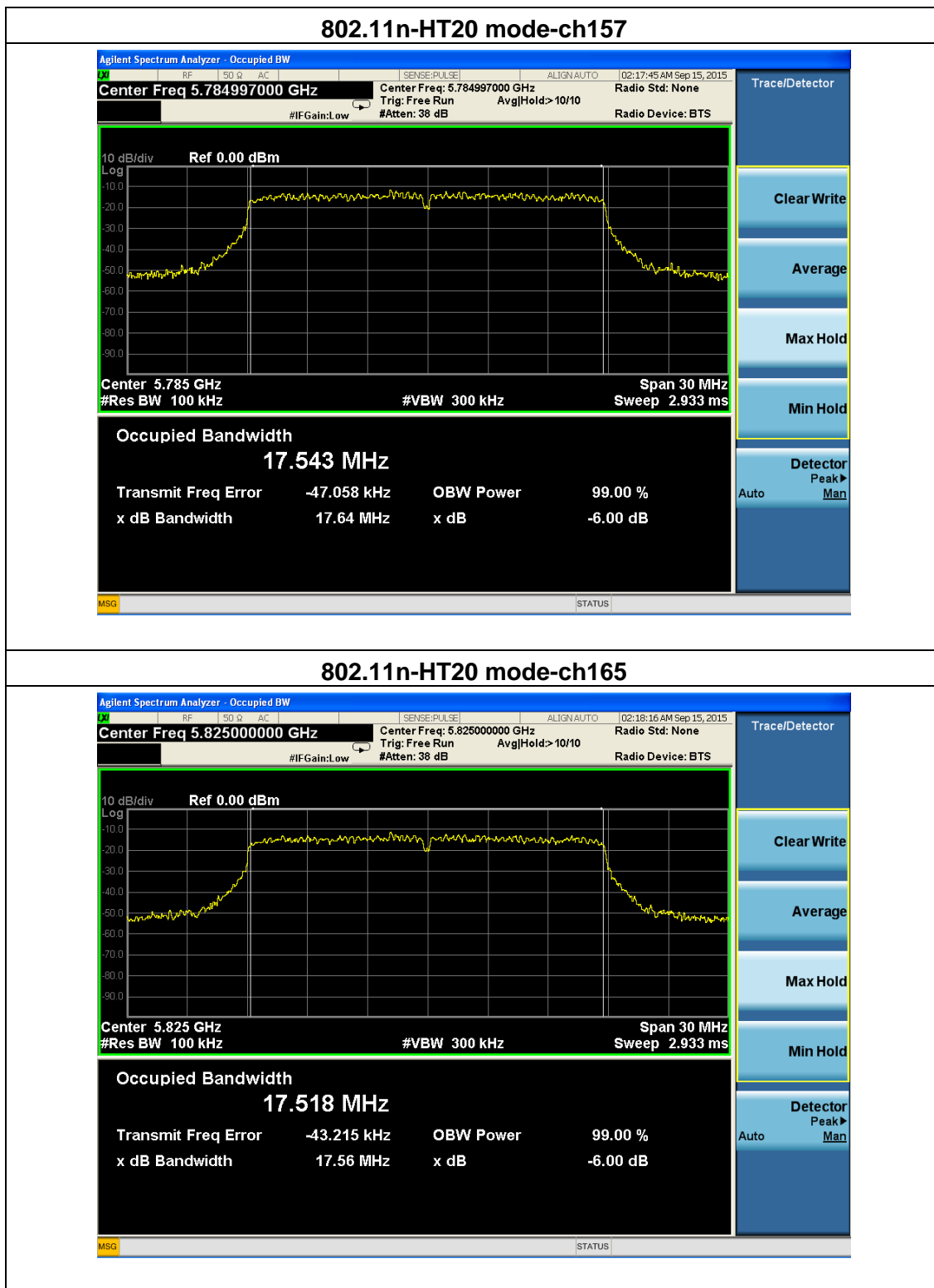

DongGuan Precise Testing Service Co., Ltd.

Building D, Baoding Technology Park, Guangming Road 2, Guangming Community, Dongcheng District, Dongguan, Guangdong, China

Tel: 86-769-23368601

Fax: 86-769-23368602

http:// www.pts-testing.com

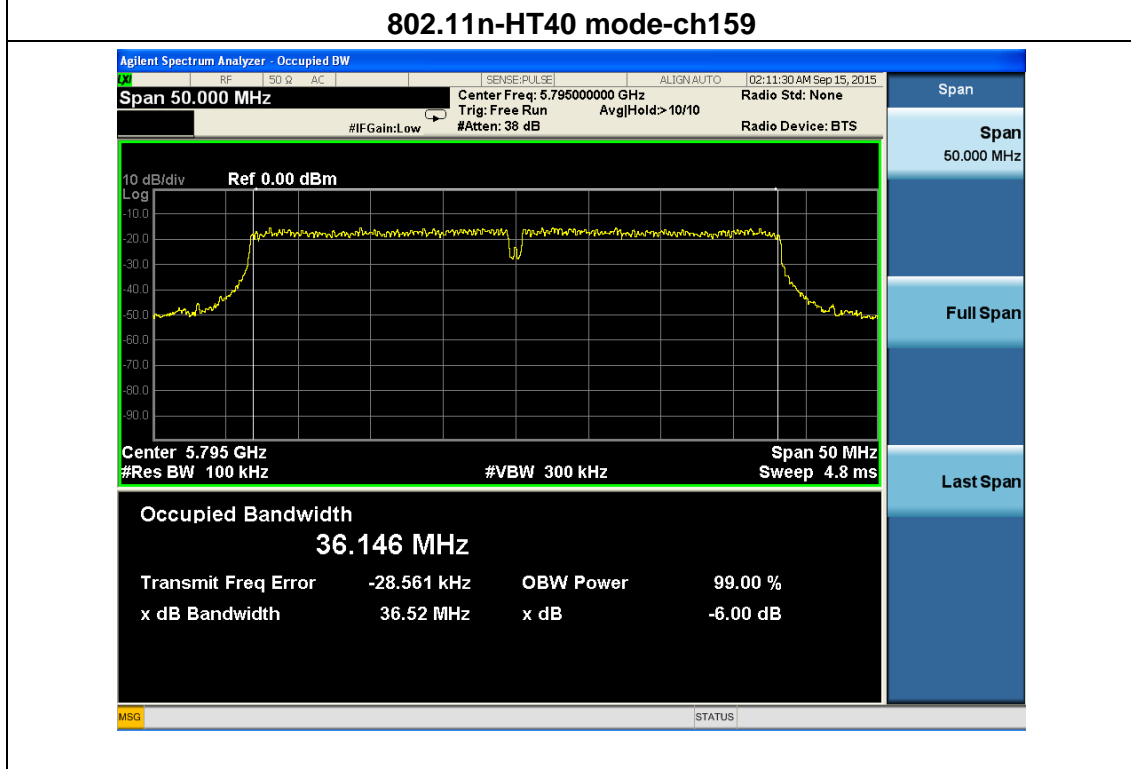
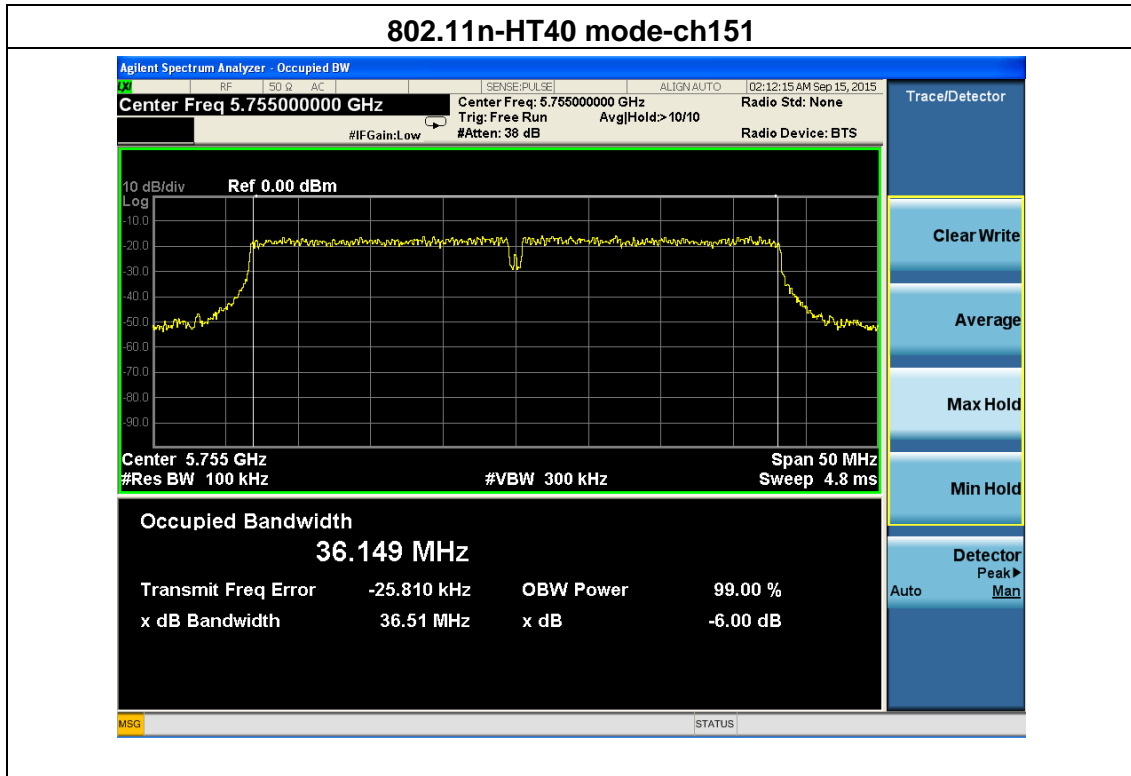

DongGuan Precise Testing Service Co., Ltd.

Building D, Baoding Technology Park, Guangming Road 2, Guangming Community, Dongcheng District, Dongguan, Guangdong, China

Tel: 86-769-23368601

Fax: 86-769-23368602

http:// www.pts-testing.com

802.11ac(20MHz) mode-ch149

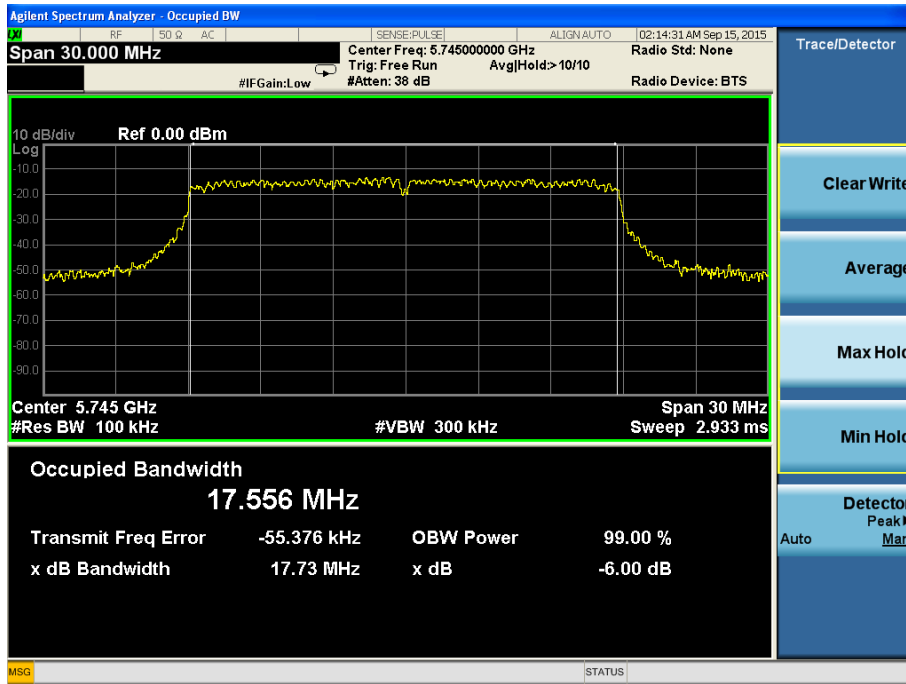

802.11ac(20MHz) mode-ch157

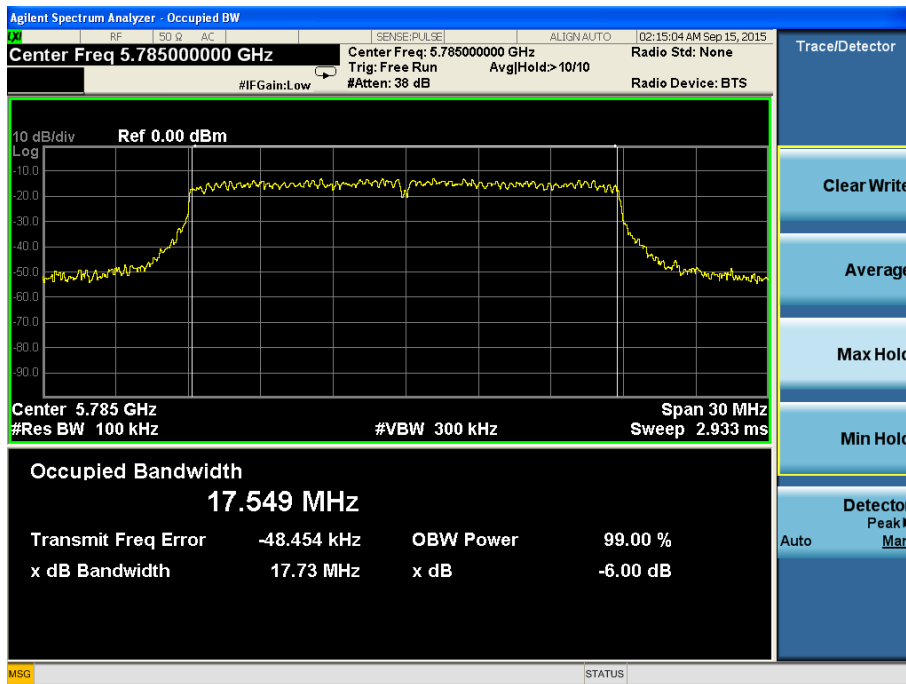

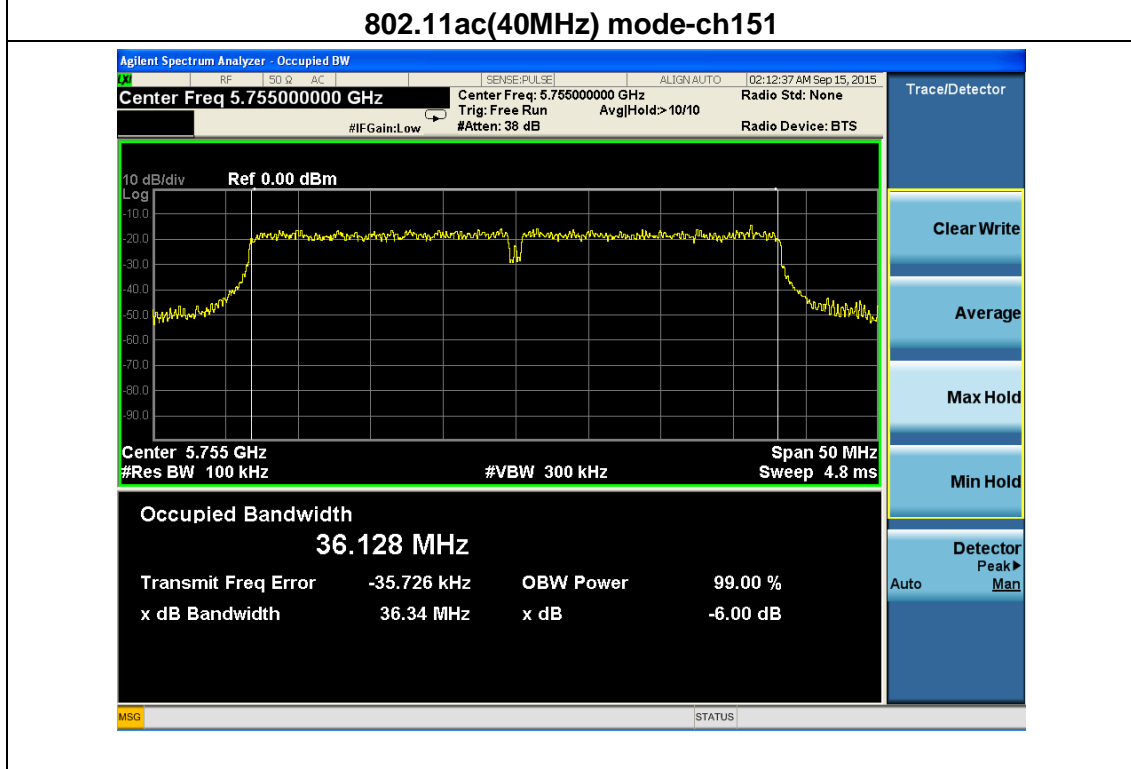
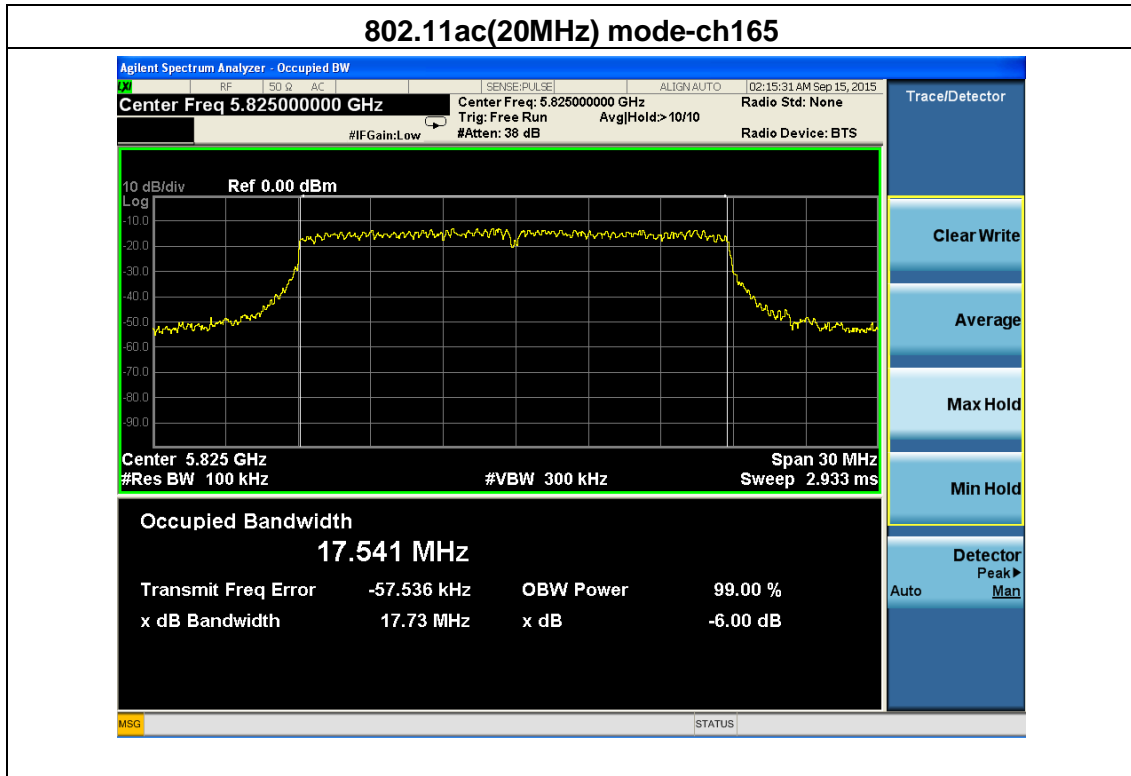

DongGuan Precise Testing Service Co., Ltd.

Building D, Baoding Technology Park, Guangming Road 2, Guangming Community, Dongcheng District, Dongguan, Guangdong, China

Tel: 86-769-23368601

Fax: 86-769-23368602

http:// www.pts-testing.com

802.11ac(40MHz) mode-ch159

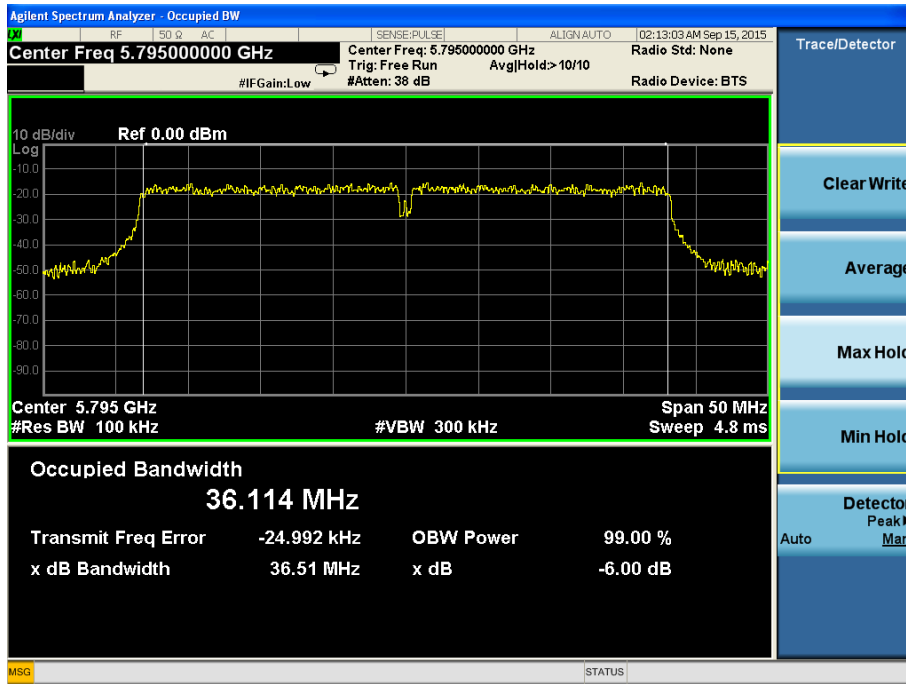

802.11ac(80MHz) mode-ch155

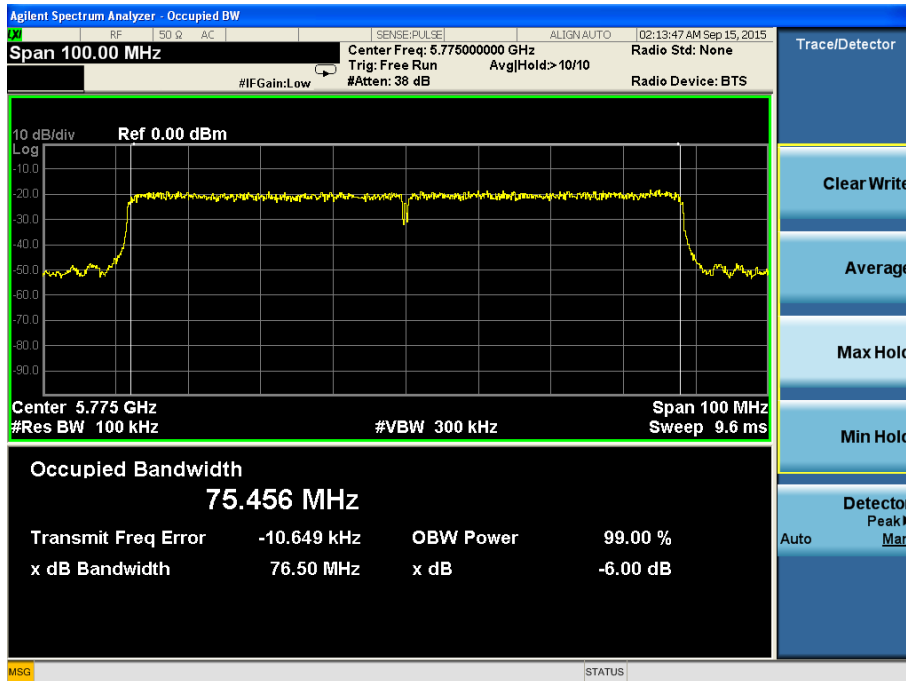

DongGuan Precise Testing Service Co., Ltd.

Building D, Baoding Technology Park, Guangming Road 2, Guangming Community, Dongcheng District, Dongguan, Guangdong, China

Tel: 86-769-23368601

Fax: 86-769-23368602

http:// www.pts-testing.com

7. PEAK EXCURSION TEST

7.1 APPLICABLE STANDARD

The ratio of the peak excursion of the modulation envelope (measured using a peak hold function) to the maximum conducted output power (measured as specified above) shall not exceed 13 dB across any 1 MHz bandwidth or the emissions bandwidth whichever is less.

7.2 TEST PROCEDURE

1. The transmitter output is connected to the spectrum analyzer.
2. Trace A, Set RBW = 1MHz, VBW = 3MHz, Span >26dB bandwidth, Max. hold.
3. Delta Mark trace A Maximum frequency and trace B same frequency.
4. Repeat the above procedure until measurements for all frequencies were complete.

7.3 DEVIATION FROM STANDARD

No deviation.

7.4 TEST SETUP

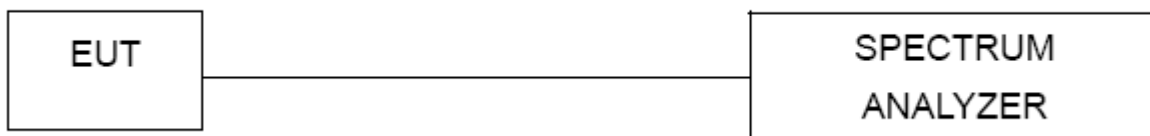

7.5 EUT OPERATION CONDITIONS

The EUT tested system was configured as the statements of 2.4 Unless otherwise a special operating condition is specified in the follows during the testing.

7.6 TEST RESULT FOR CONDUCTED SPURIOUS EMISSIONS TEST

EUT :	Wireless USB Adapter	Model Name :	GWF-5B06
Temperature :	25 °C	Relative Humidity :	60%
Pressure :	1012 hPa	Test Voltage :	DC 5V

Test Channel	Frequency (MHz)	Peak Excursion (dB)	Limit (dB)	Result
TX 802.11a Mode				
CH149	5745	2.838	13	Complies
CH157	5785	4.739	13	Complies
CH165	5825	3.009	13	Complies
TX 802.11n-HT20 Mode				
CH149	5745	3.249	13	Complies
CH157	5785	4.102	13	Complies
CH165	5825	4.122	13	Complies
TX 802.11n-HT40 Mode				
CH151	5755	3.350	13	Complies
CH159	5785	3.673	13	Complies
TX 802.11ac(20MHz) Mode				
CH149	5745	2.874	13	Complies
CH157	5785	2.591	13	Complies
CH165	5825	2.772	13	Complies
TX 802.11ac(40MHz) Mode				
CH151	5755	2.939	13	Complies
CH159	5785	3.551	13	Complies
TX 802.11ac(80MHz) Mode				
CH155	5775	3.122	13	Complies

DongGuan Precise Testing Service Co., Ltd.

Building D, Baoding Technology Park, Guangming Road 2, Guangming Community, Dongcheng District, Dongguan, Guangdong, China

Tel: 86-769-23368601

Fax: 86-769-23368602

[http:// www.pts-testing.com](http://www.pts-testing.com)

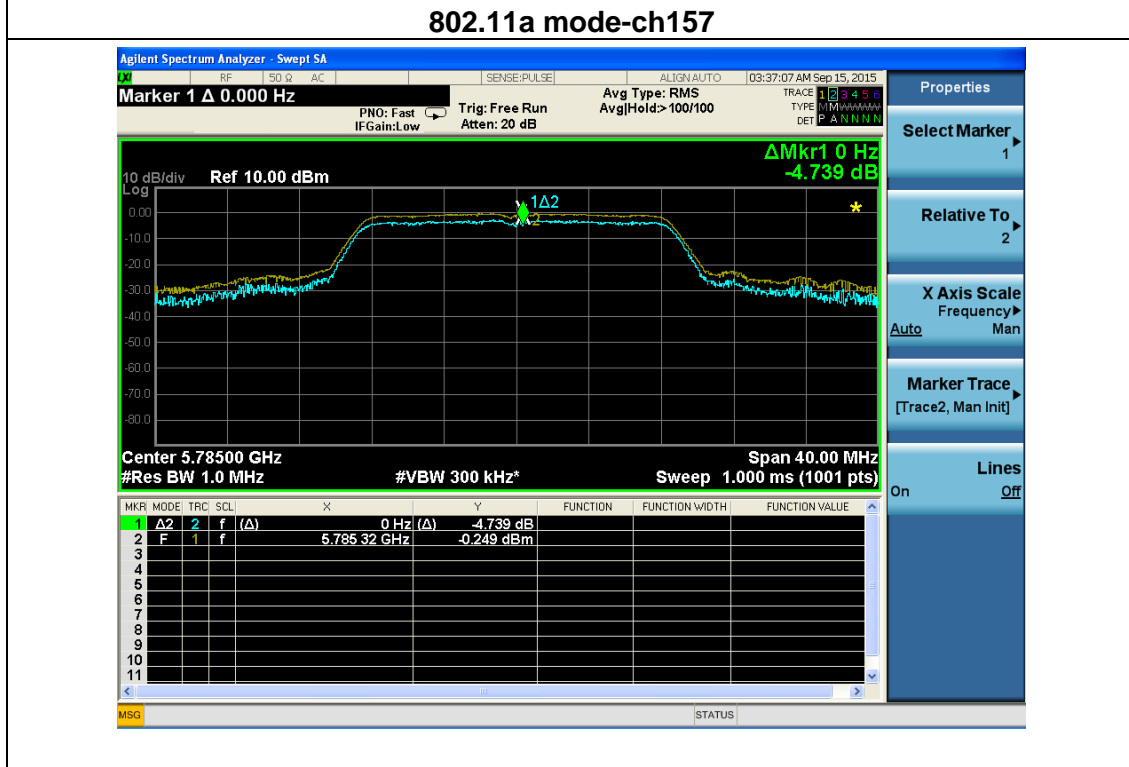
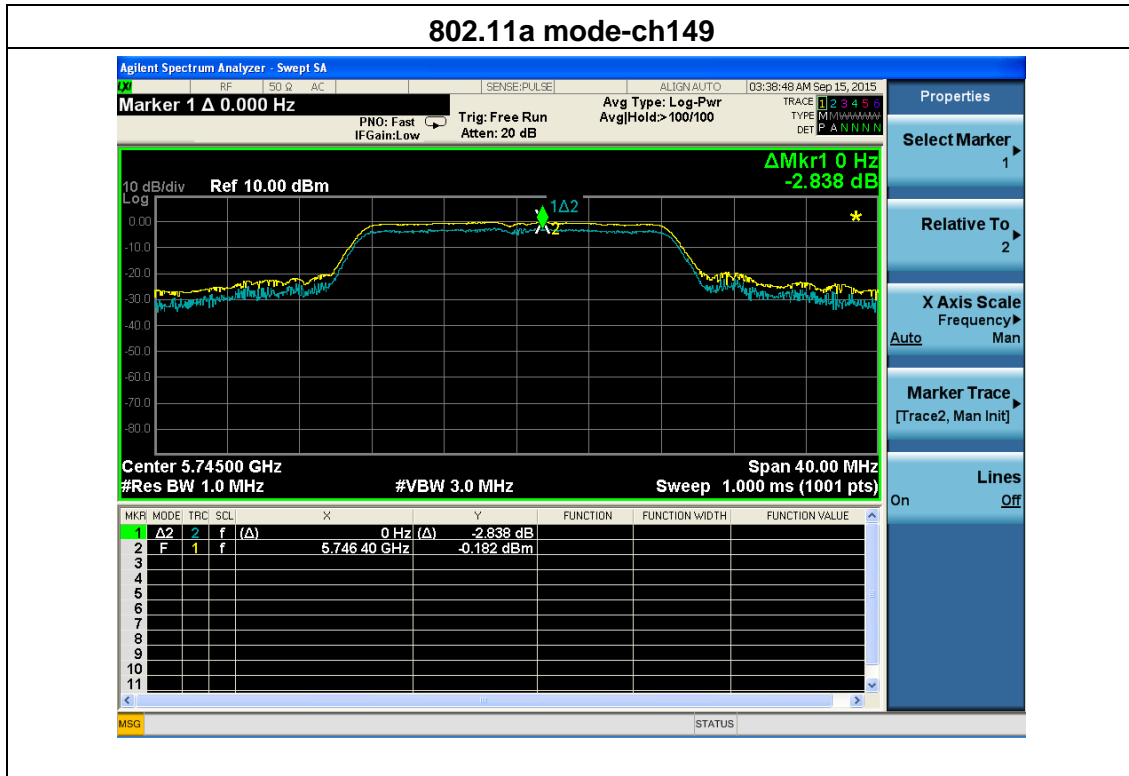

DongGuan Precise Testing Service Co., Ltd.

Building D, Baoding Technology Park, Guangming Road 2, Guangming Community, Dongcheng District, Dongguan, Guangdong, China

Tel: 86-769-23368601

Fax: 86-769-23368602

[http:// www.pts-testing.com](http://www.pts-testing.com)

802.11a mode-ch165



802.11n-HT20 mode-ch149



DongGuan Precise Testing Service Co., Ltd.

Building D, Baoding Technology Park, Guangming Road 2, Guangming Community, Dongcheng District, Dongguan, Guangdong, China

Tel: 86-769-23368601

Fax: 86-769-23368602

http:// www.pts-testing.com

802.11n-HT20 mode-ch157



802.11n-HT20 mode-ch165

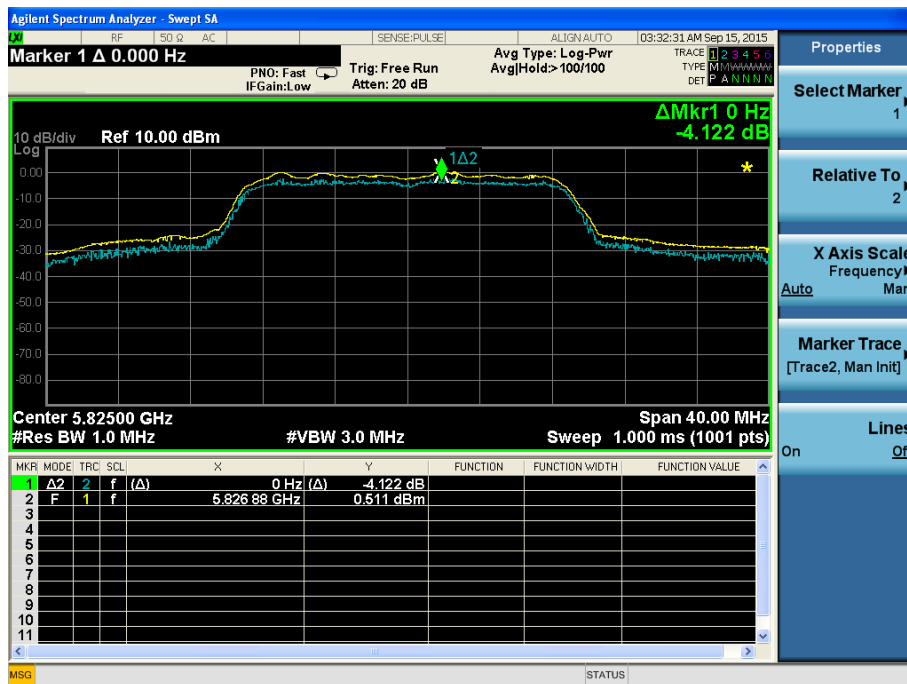

DongGuan Precise Testing Service Co., Ltd.

Building D, Baoding Technology Park, Guangming Road 2, Guangming Community, Dongcheng District, Dongguan, Guangdong, China

Tel: 86-769-23368601

Fax: 86-769-23368602

http:// www.pts-testing.com

802.11n-HT40 mode-ch151



802.11n-HT40 mode-ch159



DongGuan Precise Testing Service Co., Ltd.

Building D, Baoding Technology Park, Guangming Road 2, Guangming Community, Dongcheng District, Dongguan, Guangdong, China

Tel: 86-769-23368601

Fax: 86-769-23368602

http:// www.pts-testing.com

802.11ac(20MHz) mode-ch149

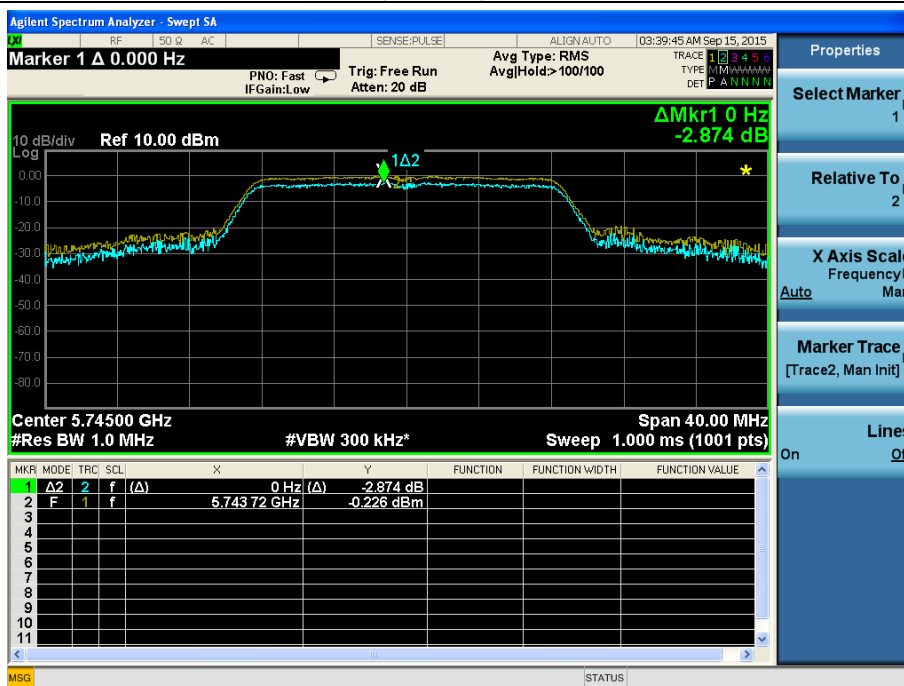

802.11ac(20MHz) mode-ch157



DongGuan Precise Testing Service Co., Ltd.

Building D, Baoding Technology Park, Guangming Road 2, Guangming Community, Dongcheng District, Dongguan, Guangdong, China

Tel: 86-769-23368601

Fax: 86-769-23368602

http:// www.pts-testing.com

802.11ac(20MHz) mode-ch165



802.11ac(40MHz) mode-ch151



DongGuan Precise Testing Service Co., Ltd.

Building D, Baoding Technology Park, Guangming Road 2, Guangming Community, Dongcheng District, Dongguan, Guangdong, China

Tel: 86-769-23368601

Fax: 86-769-23368602

http:// www.pts-testing.com

802.11ac(40MHz) mode-ch159



802.11ac(80MHz) mode-ch155

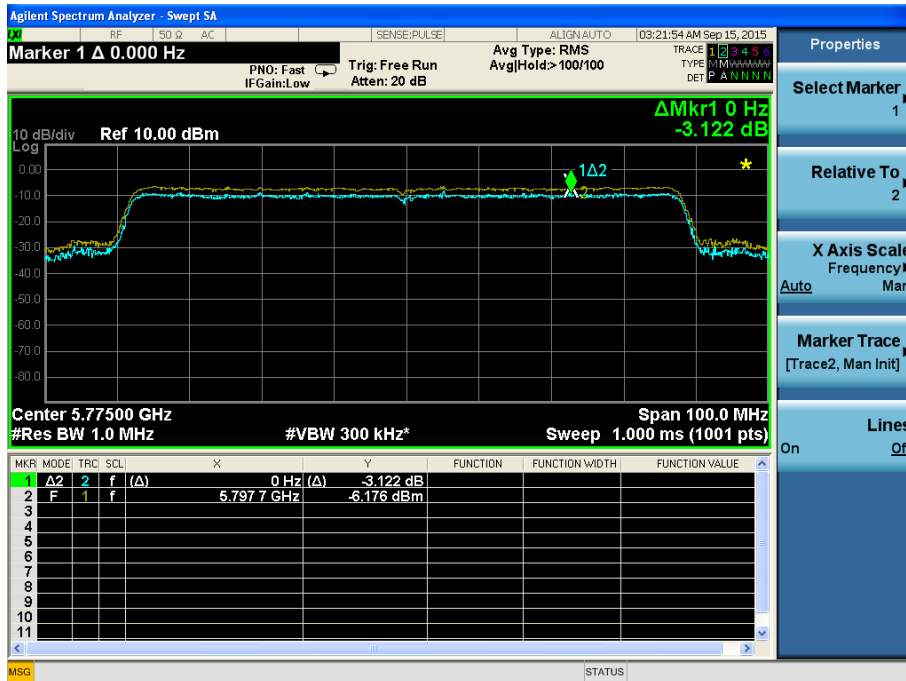

DongGuan Precise Testing Service Co., Ltd.

Building D, Baoding Technology Park, Guangming Road 2, Guangming Community, Dongcheng District, Dongguan, Guangdong, China

Tel: 86-769-23368601

Fax: 86-769-23368602

http:// www.pts-testing.com

8. FREQUENCY STABILITY TEST

8.1 APPLICABLE STANDARD

Manufacturers of U-NII devices are responsible for ensuring frequency stability such that an emissions is maintained within the band of operation under all conditions of normal operation as specified in the user's manual or $\pm 20\text{ppm}$ (IEEE 802.11n specification).

8.2 TEST PROCEDURE

1. The transmitter output (antenna port) was connected to the spectrum analyzer.
2. EUT have transmitted absence of modulation signal and fixed channelize.
3. Set the spectrum analyzer span to view the entire absence of modulation emissions bandwidth.
4. Set RBW = 10 kHz, VBW = 10 kHz with peak detector and maxhold settings.
5. f_c is declaring of channel frequency. Then the frequency error formula is $(f_c - f) / f_c \times 10^6 \text{ ppm}$ and the limit is less than $\pm 20\text{ppm}$ (IEEE 802.11n specification).
6. The test extreme voltage is to change the primary supply voltage from 85 to 115 percent of the nominal value
7. Extreme temperature rule is $-30^\circ\text{C} \sim 50^\circ\text{C}$.

8.3 DEVIATION FROM STANDARD

No deviation.

8.4 TEST SETUP



8.5 EUT OPERATION CONDITIONS

The EUT tested system was configured as the statements of 2.4 Unless otherwise a special operating condition is specified in the follows during the testing.

8.6 TEST RESULT FOR CONDUCTED SPURIOUS EMISSIONS TEST

EUT :	Wireless USB Adapter	Model Name :	GWF-5B06
Temperature :	25 °C	Relative Humidity :	60%
Pressure :	1012 hPa	Test Voltage :	DC 5V

Test Result for 802.11a:

Voltage vs. Frequency Stability

Voltage (V)	Measure Frequency (MHz)
4.5	5785.0059
5.0	5785.0076
5.5	5785.0044
Max. Deviation (MHz)	0.0076
Max. Deviation (ppm)	1.31

Temperature vs. Frequency Stability

Temperature (°C)	Measure Frequency (MHz)
-30	5785.0073
-20	5785.0054
-10	5785.0047
0	5785.0061
+10	5785.0071
+20	5785.0068
+30	5785.0059
+40	5785.0035
+50	5785.0028
Max. Deviation (MHz)	0.0073
Max. Deviation (ppm)	1.26

DongGuan Precise Testing Service Co., Ltd.

Building D, Baoding Technology Park, Guangming Road 2, Guangming Community, Dongcheng District, Dongguan, Guangdong, China

Tel: 86-769-23368601

Fax: 86-769-23368602

[http:// www.pts-testing.com](http://www.pts-testing.com)

Test Result for 802.11n-HT20:

Voltage vs. Frequency Stability

Voltage	Measure Frequency (MHz)
(V)	5785
4.5	5785.0036
5.0	5785.0057
5.5	5785.0061
Max. Deviation (MHz)	0.0061
Max. Deviation (ppm)	1.05

Temperature vs. Frequency Stability

Temperature	Measure Frequency (MHz)
(°C)	5785
-30	5785.0034
-20	5785.0067
-10	5785.0021
0	5785.0053
+10	5785.0058
+20	5785.0046
+30	5785.0062
+40	5785.0055
+50	5785.0031
Max. Deviation (MHz)	0.0067
Max. Deviation (ppm)	1.16

Test Result for 802.11n-HT40:

Voltage vs. Frequency Stability

Voltage	Measure Frequency (MHz)
(V)	5755
4.5	5755.0054
5.0	5755.0031
5.5	5755.0065
Max. Deviation (MHz)	0.0065
Max. Deviation (ppm)	1.13

Temperature vs. Frequency Stability

Temperature	Measure Frequency (MHz)
(°C)	5755
-30	5755.0064
-20	5755.0033
-10	5755.0056
0	5755.0028
+10	5755.0021
+20	5755.0035
+30	5755.0067
+40	5755.0013
+50	5755.0044
Max. Deviation (MHz)	0.0067
Max. Deviation (ppm)	1.16

DongGuan Precise Testing Service Co., Ltd.

Building D, Baoding Technology Park, Guangming Road 2, Guangming Community, Dongcheng District, Dongguan, Guangdong, China

Test Result for 802.11ac(20MHz):

Voltage vs. Frequency Stability

Voltage	Measure Frequency (MHz)
(V)	5785
4.5	5785.0064
5.0	5785.0033
5.5	5785.0041
Max. Deviation (MHz)	0.0064
Max. Deviation (ppm)	1.10

Temperature vs. Frequency Stability

Temperature	Measure Frequency (MHz)
(°C)	5785
-30	5785.0023
-20	5785.0044
-10	5785.0056
0	5785.0037
+10	5785.0063
+20	5785.0056
+30	5785.0039
+40	5785.0051
+50	5785.0047
Max. Deviation (MHz)	0.0063
Max. Deviation (ppm)	1.09

Test Result for 802.11ac(40MHz):

Voltage vs. Frequency Stability

Voltage	Measure Frequency (MHz)
(V)	5755
4.5	5755.00031
5.0	5755.0045
5.5	5755.0051
Max. Deviation (MHz)	0.0051
Max. Deviation (ppm)	0.89

Temperature vs. Frequency Stability

Temperature	Measure Frequency (MHz)
(°C)	5755
-30	5755.0045
-20	5755.0032
-10	5755.0067
0	5755.0034
+10	5755.0048
+20	5755.0032
+30	5755.0029
+40	5755.0057
+50	5755.0062
Max. Deviation (MHz)	0.0067
Max. Deviation (ppm)	1.16

DongGuan Precise Testing Service Co., Ltd.

Building D, Baoding Technology Park, Guangming Road 2, Guangming Community, Dongcheng District, Dongguan, Guangdong, China

Test Result for 802.11ac(80MHz):

Voltage vs. Frequency Stability

Voltage	Measure Frequency (MHz)
(V)	5775
4.5	5775.0045
5.0	5775.0023
5.5	5775.0057
Max. Deviation (MHz)	0.0057
Max. Deviation (ppm)	0.99

Temperature vs. Frequency Stability

Temperature	Measure Frequency (MHz)
(°C)	5775
-30	5775.0043
-20	5775.0014
-10	5775.0034
0	5775.0056
+10	5775.0067
+20	5775.0051
+30	5775.0038
+40	5775.0063
+50	5775.0046
Max. Deviation (MHz)	0.0067
Max. Deviation (ppm)	1.16

DongGuan Precise Testing Service Co., Ltd.

Building D, Baoding Technology Park, Guangming Road 2, Guangming Community, Dongcheng District, Dongguan, Guangdong, China

Tel: 86-769-23368601

Fax: 86-769-23368602

[http:// www.pts-testing.com](http://www.pts-testing.com)

9. ANTENNA REQUIREMENT

9.1 STANDARD REQUIREMENT

15.203 requirement: For intentional device, according to 15.203: an intentional radiator shall be designed to ensure that no antenna other than that furnished by the responsible party shall be used with the device.

9.2 EUT ANTENNA

The EUT antenna is Integrated(PCB) antenna and the gain is 2.8dBi. It's permanent attached antenna. It comply with the standard requirement.

10. EUT TEST PHOTO

Radiated Measurement Photos

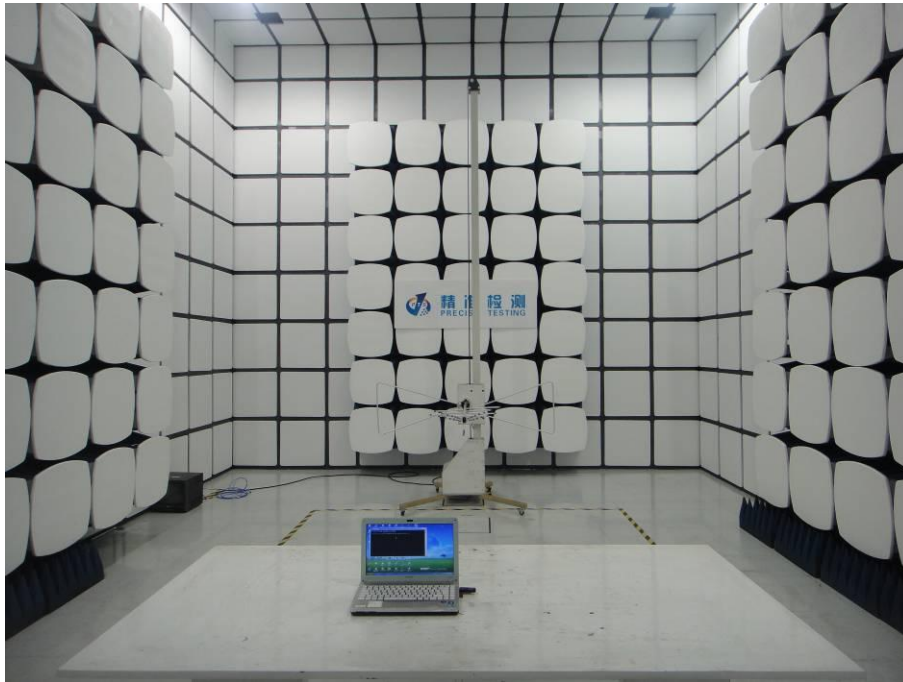

Radiated Measurement Photos

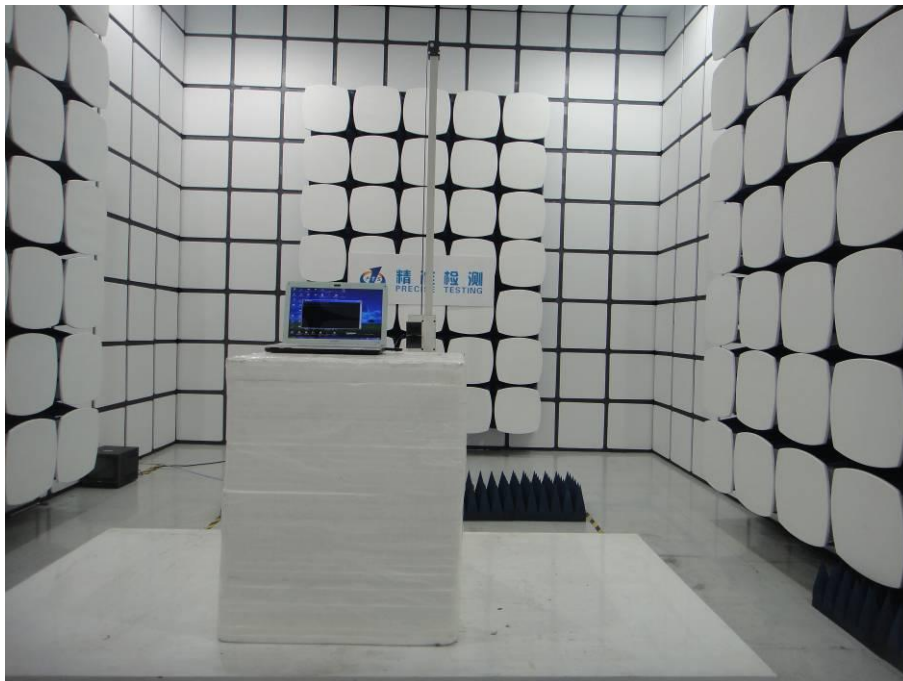

DongGuan Precise Testing Service Co., Ltd.

Building D, Baoding Technology Park, Guangming Road 2, Guangming Community, Dongcheng District, Dongguan, Guangdong, China

Tel: 86-769-23368601

Fax: 86-769-23368602

[http:// www.pts-testing.com](http://www.pts-testing.com)

Conducted Measurement Photos



DongGuan Precise Testing Service Co., Ltd.

Building D, Baoding Technology Park, Guangming Road 2, Guangming Community, Dongcheng District, Dongguan, Guangdong, China

Tel: 86-769-23368601

Fax: 86-769-23368602

[http:// www.pts-testing.com](http://www.pts-testing.com)