



FCC Part 15C Test Report

FCC ID: YWTWF5572N4B

Product Name:	300Mbps Wifi Adapter
Trademark:	N/A
Model Name :	GWF-4B06
Prepared For :	Shenzhen Ogemray Technology Co., Ltd.
Address :	3F-4F, Plant 5, Dongwu Industrial Area, North of Donghuan 1st Road, Longhua office, Longhua New District, Shenzhen , Guangdong, China
Prepared By :	Shenzhen BCTC Technology Co., Ltd.
Address :	No.101, Yousong Road, Longhua New District, Shenzhen, China
Test Date:	Jul. 06– Jul. 13, 2016
Date of Report :	Jul. 14, 2016
Report No.:	BCTC-160608467-1E



VERIFICATION OF COMPLIANCE

Applicant's name..... Shenzhen Ogemray Technology Co., Ltd.
 Address 3F-4F, Plant 5, Dongwu Industrial Area,North of Donghuan 1st Road, Longhua office, Longhua New District, Shenzhen , Guangdong, China

Manufacture's Name Shenzhen Ogemray Technology Co., Ltd.
 Address 3F-4F, Plant 5, Dongwu Industrial Area,North of Donghuan 1st Road, Longhua office, Longhua New District, Shenzhen , Guangdong, China

Product description

Product name..... 300Mbps Wifi Adapter
 Model Name: GWF-4B06
 Standards: FCC Part15.407
 ANSI C63.10-2013
 KDB789033 D02 General UNII Test Procedures New Rules v01r02

This device described above has been tested by BCTC, and the test results show that the equipment under test (EUT) is in compliance with the FCC requirements. And it is applicable only to the tested sample identified in the report.

This report shall not be reproduced except in full, without the written approval of BCTC, this document may be altered or revised by BCTC, personal only, and shall be noted in the revision of the document.

Test Result **Pass**

Testing Engineer : Eric Yang
 Eric Yang

Reviewer : Jade Yang
 (Supervisor) Jade Yang

Approved & Authorized : Carson Zhang
 Signer(Manager)





TABLE OF CONTENTS

	Page
Test Report Declaration	
1. TEST SUMMARY	4
2. GENERAL PRODUCT INFORMATION	5
2.1. Product Function	5
2.2. Description of Device (EUT).....	5
2.3. Test Supporting System	6
2.4. Independent Operation Modes.....	7
2.5. Test Sites	7
2.6. List of Test and Measurement Instruments	8
3. TEST SET-UP AND OPERATION MODES	9
3.1. Principle of Configuration Selection	9
3.2. Block Diagram of Test Set-up.....	9
3.3. Test Operation Mode and Test Software	9
3.4. Special Accessories and Auxiliary Equipment.....	9
3.5. Countermeasures to Achieve EMC Compliance	9
4. EMISSION TEST RESULTS	10
4.1. Conducted Emission Measurement.....	10
4.2. Radiated Emission Measurement.....	14
5. BAND EDGE COMPLIANCE TEST	32
5.1. Limits	32
5.2. Test setup	32
5.3. Test Data	32
6. 26DB AND 99% BANDWIDTH TEST	34
6.1. Measurement Procedure.....	34
7. OUTPUT POWER TEST	44
7.1. Limits	44
7.2. Test setup	44
7.3. Test result	45
8. PEAK POWER SPECTRAL DENSITY TEST	46
8.1. Limits	46
8.2. Test setup	46
8.3. Test data.....	47
9. DUTY CYCLE TEST SIGNAL	56
10. FREQUENCY STABILITY	58
10.1. Limits	58
10.2. Test setup	58
10.3. Test data.....	59
11. TRANSMISSION IN THE ABSENCE OF DATA	65
11.1. Limits	65
11.2. Test result	65
12. PHOTOGRAPHS OF TEST SET-UP	66
13. PHOTOGRAPHS OF THE EUT	68



1.TEST SUMMARY

Test Items	Test Requirement	Result
Conducted Emissions	15.207	PASS
Radiated Emissions	15.407(b), 15.209	PASS
26dB bandwidth and 99%dB Bandwidth	15.403(i) 15.407(e)	PASS
Power density	15.407 (a)	PASS
Maximum Peak Output Power	15.407 (a)	PASS
Emissions from out of band	15.407 (b)	PASS
Transmission in case of Absence of Information	15.407(c)	PASS
Frequency Stability	15.407(g)	PASS
Antenna Requirement	15.203	PASS



2.GENERAL PRODUCT INFORMATION

2.1. Product Function

Refer to Technical Construction Form and User Manual.

2.2. Description of Device (EUT)

Product Name:	300Mbps Wifi Adapter
Model No.:	GWF-4B06
Trade Name:	N/A
Operation Frequency:	5180-5240, 5745-5825MHz(802.11a/n(HT20)) 5190-5230, 5755-5795MHz(802.11n(HT40))
Channel numbers:	See channel list
Modulation technology:	64QAM, 16QAM, QPSK, BPSK for OFDM
Data speed (IEEE 802.11a):	6Mbps, 9Mbps, 12Mbps, 18Mbps, 24Mbps, 36Mbps, 48Mbps,54Mbps
Data speed (IEEE 802.11n):	Up to 300Mbps
Antenna Type:	PCB antenna*2
Antenna gain:	2.0dBi
Power supply:	DC 5V

Note1: Directional Gain=2dBi+10log(2)=5.01dBi

Note2: The EUT incorporates a mimo funtion. Physically, the EUT provide two completed transmitter and two receivers.



Channel List for 802.11a/n(20)			
Channel	Frequency (MHz)	Channel	Frequency (MHz)
36	5180	44	5220
40	5200	48	5240

Channel List for 802.11a/n(20)			
Channel	Frequency (MHz)	Channel	Frequency (MHz)
149	5745	161	5805
153	5765	165	5825
157	5785		

Channel List for 802.11n(40)			
Channel	Frequency (MHz)	Channel	Frequency (MHz)
38	5190	46	5230

Channel List for 802.11n(40)			
Channel	Frequency (MHz)	Channel	Frequency (MHz)
151	5755	159	5795

2.3. Test Supporting System

None.



2.4. Independent Operation Modes

The basic operation modes are:

These is Digital Transmission system (DTS) and have modulation OFDM, DSSS, DBPSK, DQPSK, CCK, 16QAM, 64QAM. According exploratory test, EUT will have maximum output power in those data rate (802.11a/n: MCS0), so those data rate were used for all test. The equipment enables high-speed access without wires to network assets. This adapter uses the IEEE 802.11 protocol to enable wireless communications between the host and Wireless router.

802.11a/n(20)

Frequency	Band 1	Band 4
Low	5180MHz	5745MHz
Middle	5200MHz	5785MHz
High	5240MHz	5825MHz

802.11n(40)

Frequency	Band 1	Band 4
Low	5190MHz	5755MHz
High	5230MHz	5795MHz

Note: for conducted emission test, we pretest all mode, the worst mode was 802.11a channel 36.

for radiated emissions test, we pretest all mode, the worst mode was 802.11a/n20

The worst mode's data was recording and show in the test report.

2.5. Test Sites

2.5.1. Test Facilities

Lab Qualifications : FCC Registration No.:187086



2.6. List of Test and Measurement Instruments

Conduction test equipment

Item	Kind of Equipment	Manufacturer	Type No.	Serial No.	Last calibration	Calibrated until	Calibration period
1	Test Receiver	R&S	ESCI	1166.5950K03-101165-ha	2016.07.06	2017.07.05	1 year
2	LISN	R&S	NSLK8126	8126466	2015.08.24	2016.08.23	1 year
3	LISN	R&S	NSLK8126	8126487	2015.08.24	2016.08.23	1 year
4	50Ω Coaxial Switch	Anritsu	MP59B	6200264417	2016.07.06	2017.07.05	1 year
5	RF cables	R&S	R204	R20X	2016.07.06	2017.07.05	1 year

Radiation test, Band-edge test and 6db bandwidth test equipment

Item	Kind of equipment	Manufacturer	Type No.	Serial No.	Last calibration	Calibrated until	Calibration period
1	Spectrum Analyzer	Agilent	E4407B	MY45108040	2016.07.06	2017.07.05	1 year
2	Test Receiver	R&S	ESPI	101318	2016.07.06	2017.07.05	1 year
3	Bilog Antenna	R&S	VULB9168	VULB9168-438	2016.07.06	2017.07.05	1 year
4	50Ω Coaxial Switch	Anritsu	MP59B	6200264416	2016.07.06	2017.07.05	1 year
5	Spectrum Analyzer	ADVANTEST	R3132	150900201	2016.07.06	2017.07.05	1 year
6	Horn Antenna	R&S	HF906	10027	2016.07.06	2017.07.05	1 year
7	Horn Antenna	R&S	BBHA 9170	9170-181	2016.07.06	2017.07.05	1 year
8	Amplifier	R&S	BBV9743	9743-019	2015.12.22	2016.12.21	1 year
9	Loop Antenna	ARA	PLGWF-4B0630/B	1029	2016.07.06	2017.07.05	1 year
10	RF cables	R&S	R203	R20X	2016.07.06	2017.07.05	1 year
11	Antenna connector	Florida RFLabs	Lab-Fle	RF 01#	2016.07.06	2017.07.05	1 year
12	Power Metter	ANRITSU	ML2487A	6K00001568	2016.07.06	2017.07.05	1 year
13	Power Sensor (AV)	ANRITSU	ML2491A	030989	2016.07.06	2017.07.05	1 year
14	Signal Analyzer	Agilent	N9010A	MY48030494	2016.07.06	2017.07.05	1 year
15	Test Receiver	R&S	ESU 40	100376	2016.07.06	2017.07.05	1 year

3. TEST SET-UP AND OPERATION MODES

3.1. Principle of Configuration Selection

Emission: The equipment under test (EUT) was configured to measure its highest possible radiation level. The test modes were adapted accordingly in reference to the Operating Instructions.

3.2. Block Diagram of Test Set-up

System Diagram of Connections between EUT and Simulators

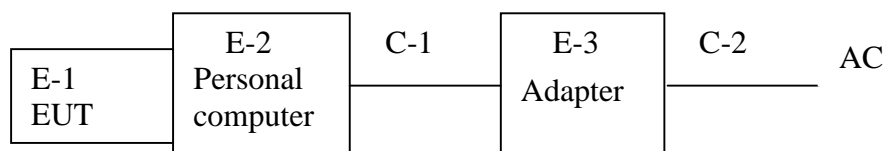

(EUT: 300Mbps Wifi Adapter)

3.3. Test Operation Mode and Test Software

None.

3.4. Special Accessories and Auxiliary Equipment

3.5. Countermeasures to Achieve EMC Compliance

None.



4. EMISSION TEST RESULTS

4.1. Conducted Emission Measurement

POWER LINE CONDUCTED EMISSION Limits (Frequency Range 150KHz-30MHz)

FREQUENCY (MHz)	Class B (dBuV)		Standard
	Quasi -peak	Average	
0.15 -0.5	66 - 56 *	56 - 46 *	FCC
0.50 -5.0	56.00	46.00	FCC
5.0 -30.0	60.00	50.00	FCC

Note:

- (1) The tighter limit applies at the band edges.
- (2) The limit of " * " marked band means the limitation decreases linearly with the logarithm of the frequency in the range.

The following table is the setting of the receiver

Receiver Parameters	Setting
Attenuation	10 dB
Start Frequency	0.15 MHz
Stop Frequency	30 MHz
IF Bandwidth	9 kHz

4.1.1. TEST PROCEDURE

- a. The EUT was placed 0.8 meters from the horizontal ground plane with EUT being connected to the power mains through a line impedance stabilization network (LISN). All other support equipments powered from additional LISN(s). The LISN provide 50 Ohm/ 50uH of coupling impedance for the measuring instrument.
- b. Interconnecting cables that hang closer than 40 cm to the ground plane shall be folded back and forth in the center forming a bundle 30 to 40 cm long.
- c. I/O cables that are not connected to a peripheral shall be bundled in the center. The end of the cable may be terminated, if required, using the correct terminating impedance. The overall length shall not exceed 1 m.
- d. LISN at least 80 cm from nearest part of EUT chassis.
- e. For the actual test configuration, please refer to the related Item –EUT Test Photos.

4.1.2. DEVIATION FROM TEST STANDARD

No deviation

4.1.3. TEST SETUP

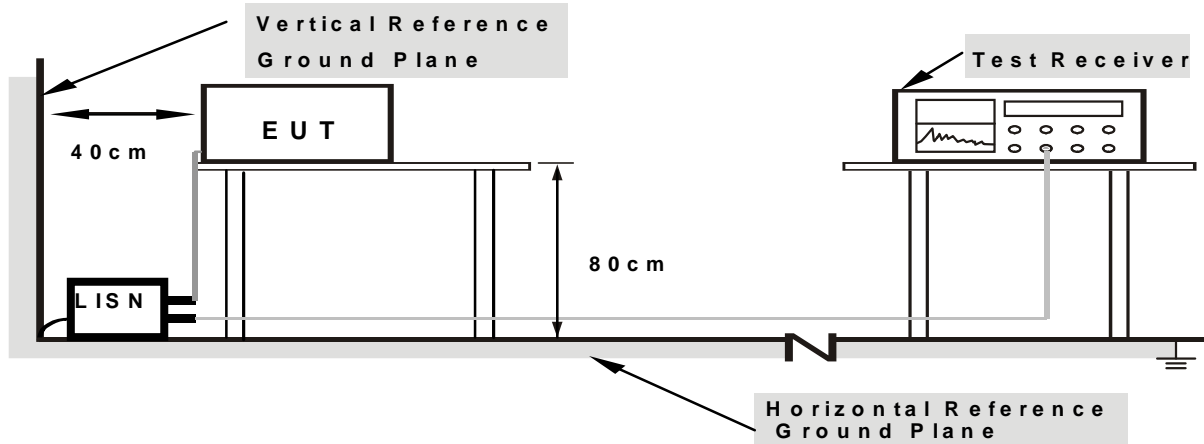

- Note: 1.Support units were connected to second LISN .
2.Both of LISNs (AMN) are 80 cm from EUT and at least 80 from other units and other metal planes

4.1.4. EUT OPERATING CONDITIONS

The EUT was configured for testing in a typical fashion (as a customer would normally use it). The EUT has been programmed to continuously transmit during test. This operating condition was tested and used to collect the included data.

We pretest all adapter's emission, only the adapter 1's data was worst and the data was recording in the report.

The data only show the worst mode.

If peak level comply with Quasi-Peak limit, then the Quasi-Peak level is deemed to comply with Quasi-Peak limit.

We pretest AC 120V and AC 240V, the worst voltage was AC 120V and the data recording in the report.

4.1.5. TEST RESULTS



Temperature:	26 °C	Relative Humidity:	54%
Pressure:	1010hPa	Phase :	L
Test Voltage :	DC 5V from PC	Test Mode:	Link Mode

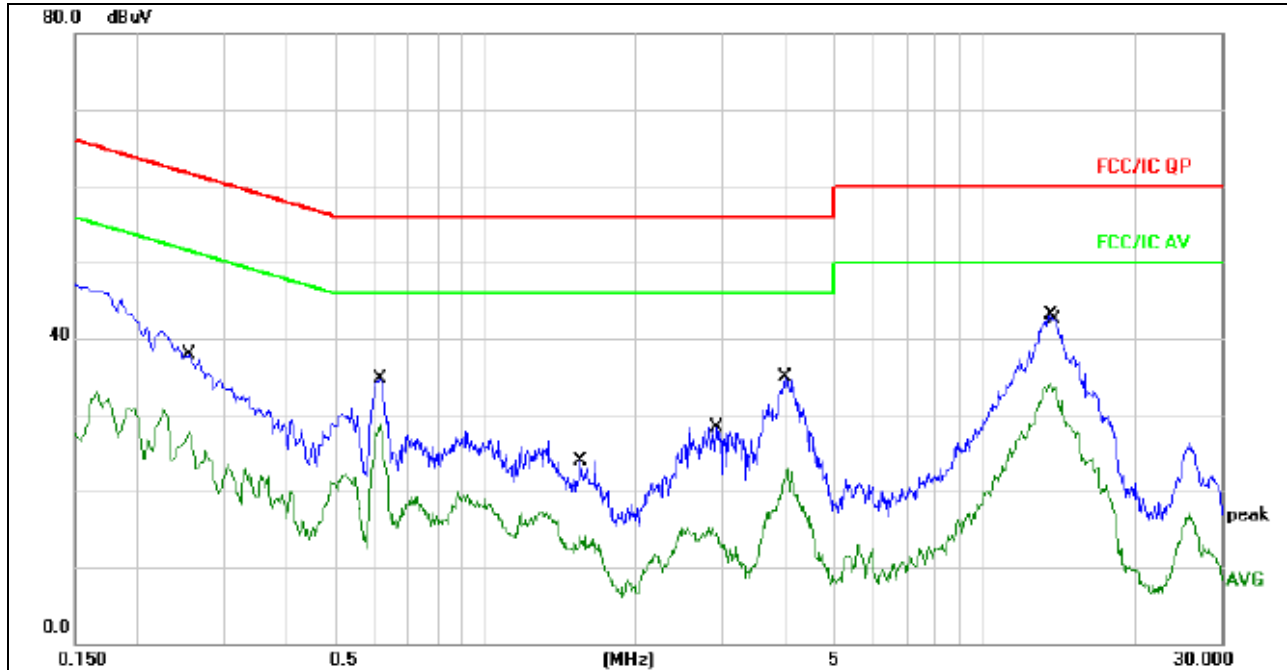

Remark:

1. All readings are Quasi-Peak and Average values.
2. Factor = Insertion Loss + Cable Loss.

No. Mk.	Freq. MHz	Reading Level dBuV	Correct Factor dB	Measurement dBuV	Limit dBuV	Over dB	Detector	Comment
1	0.2540	27.73	10.08	37.81	61.62	-23.81	QP	
2	0.2540	15.56	10.08	25.64	51.62	-25.98	AVG	
3	0.6139	24.51	10.13	34.64	56.00	-21.36	QP	
4	0.6139	18.65	10.13	28.78	46.00	-17.22	AVG	
5	1.5580	13.73	10.18	23.91	56.00	-32.09	QP	
6	1.5580	3.92	10.18	14.10	46.00	-31.90	AVG	
7	2.9020	18.13	10.19	28.32	56.00	-27.68	QP	
8	2.9020	4.99	10.19	15.18	46.00	-30.82	AVG	
9	4.0019	24.74	10.16	34.90	56.00	-21.10	QP	
10	4.0019	12.77	10.16	22.93	46.00	-23.07	AVG	
11	13.6819	32.91	10.14	43.05	60.00	-16.95	QP	
12 *	13.9419	23.61	10.14	33.75	50.00	-16.25	AVG	



Temperature:	26 °C	Relative Humidity:	54%
Pressure:	1010hPa	Phase :	N
Test Voltage :	DC 5V from PC	Test Mode:	Link Mode

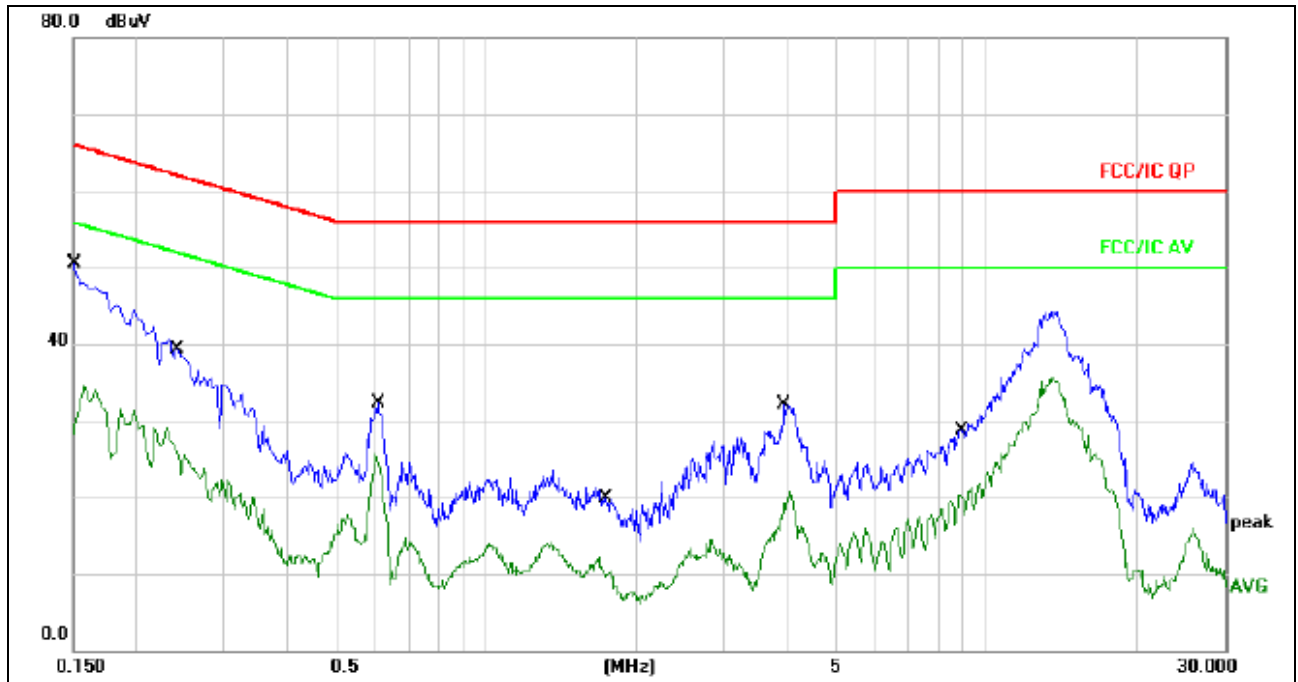

Remark:

1. All readings are Quasi-Peak and Average values.
2. Factor = Insertion Loss + Cable Loss.

No.	Mk.	Freq. MHz	Reading Level dBuV	Correct Factor dB	Measure- ment dBuV	Limit dBuV	Over dB	Detector	Comment
1	*	0.1499	40.43	10.05	50.48	66.00	-15.52	QP	
2		0.1499	24.43	10.05	34.48	56.00	-21.52	AVG	
3		0.2419	29.26	10.08	39.34	62.03	-22.69	QP	
4		0.2419	18.84	10.08	28.92	52.03	-23.11	AVG	
5		0.6097	22.20	10.13	32.33	56.00	-23.67	QP	
6		0.6097	15.63	10.13	25.76	46.00	-20.24	AVG	
7		1.7419	9.72	10.18	19.90	56.00	-36.10	QP	
8		1.7419	1.93	10.18	12.11	46.00	-33.89	AVG	
9		3.9100	18.73	10.16	28.89	56.00	-27.11	QP	
10		3.9100	10.54	10.16	20.70	46.00	-25.30	AVG	
11		8.9259	18.55	10.12	28.67	60.00	-31.33	QP	
12		8.9259	11.15	10.12	21.27	50.00	-28.73	AVG	



4.2. Radiated Emission Measurement

4.2.1. Radiated Emission Limits (Frequency Range 9kHz-1000MHz)

20dBc in any 100 kHz bandwidth outside the operating frequency band. In case the emission fall within the restricted band specified on 15.205(a), then the 15.209(a) limit in the table below has to be followed.

Frequencies (MHz)	Field Strength (micorvolts/meter)	Measurement Distance (meters)
0.009~0.490	2400/F(KHz)	300
0.490~1.705	24000/F(KHz)	30
1.705~30.0	30	30
30~88	100	3
88~216	150	3
216~960	200	3
Above 960	500	3

LIMITS OF RADIATED EMISSION MEASUREMENT (Above 1000MHz)

FREQUENCY (MHz)	Class B (dBuV/m) (at 3M)	
	PEAK	AVERAGE
Above 1000	74	54

Notes:

- (1) The limit for radiated test was performed according to FCC PART 15C.
- (2) The tighter limit applies at the band edges.
- (3) Emission level (dBuV/m)=20log Emission level (uV/m).

FREQUENCY RANGE OF RADIATED MEASUREMENT (For unintentional radiators)

Highest frequency generated or Upper frequency of measurement used in the device or on which the device operates or tunes (MHz)	Range (MHz)
Below 1.705	30
1.705 – 108	1000
108 – 500	2000
500 – 1000	5000
Above 1000	5th harmonic of the highest frequency or 40 GHz, whichever is lower



Spectrum Parameter	Setting
Attenuation	Auto
Start Frequency	1000 MHz
Stop Frequency	10th carrier harmonic
RB / VB (emission in restricted band)	1 MHz / 1 MHz for Peak, 1 MHz / 10Hz for Average

Receiver Parameter	Setting
Attenuation	Auto
Start ~ Stop Frequency	9kHz~150kHz / RB 200Hz for QP
Start ~ Stop Frequency	150kHz~30MHz / RB 9kHz for QP
Start ~ Stop Frequency	30MHz~1000MHz / RB 120kHz for QP

4.2.2. TEST PROCEDURE

- a. The measuring distance of at 3 m shall be used for measurements at frequency up to 25GHz. For frequencies above 1GHz, any suitable measuring distance may be used.
- b. The EUT was placed on the top of a rotating table 1.5 meters above the ground at a 3 meter open area test site. The table was rotated 360 degrees to determine the position of the highest radiation.
- c. The height of the equipment or of the substitution antenna shall be 1.5 m; the height of the test antenna shall vary between 1 m to 4 m. Both horizontal and vertical polarizations of the antenna are set to make the measurement.
- d. The initial step in collecting conducted emission data is a spectrum analyzer peak detector mode pre-scanning the measurement frequency range. Significant peaks are then marked and then Quasi Peak detector mode re-measured.
- e. If the Peak Mode measured value compliance with and lower than Quasi Peak Mode Limit, the EUT shall be deemed to meet QP Limits and then no additional QP Mode measurement performed.
- f. For the actual test configuration, please refer to the related Item –EUT Test Photos.
- g. For the radiated emission test above 1GHz:
Place the measurement antenna away from each area of the EUT determined to be a source of emissions at the specified measurement distance, while keeping the measurement antenna aimed at the source of emissions at each frequency of significant emissions, with polarization oriented for maximum response.
The measurement antenna may have to be higher or lower than the EUT, depending on the radiation pattern of the emission and staying aimed at the emission source for receiving the maximum signal. The final measurement antenna elevation shall be that which maximizes the emissions. The measurement antenna elevation for maximum emissions shall be restricted to a range of heights of from 1 m to 4 m above the ground or reference ground plane.

Note:

Both horizontal and vertical antenna polarities were tested and performed pretest to three orthogonal axis. The worst case emissions were reported

We pretest AC 120V and AC 240V, the worst voltage was AC 120V and the data recording in the report.

4.2.3. DEVIATION FROM TEST STANDARD

No deviation

4.2.4. TEST SETUP

(A) Radiated Emission Test-Up Frequency Below 30MHz

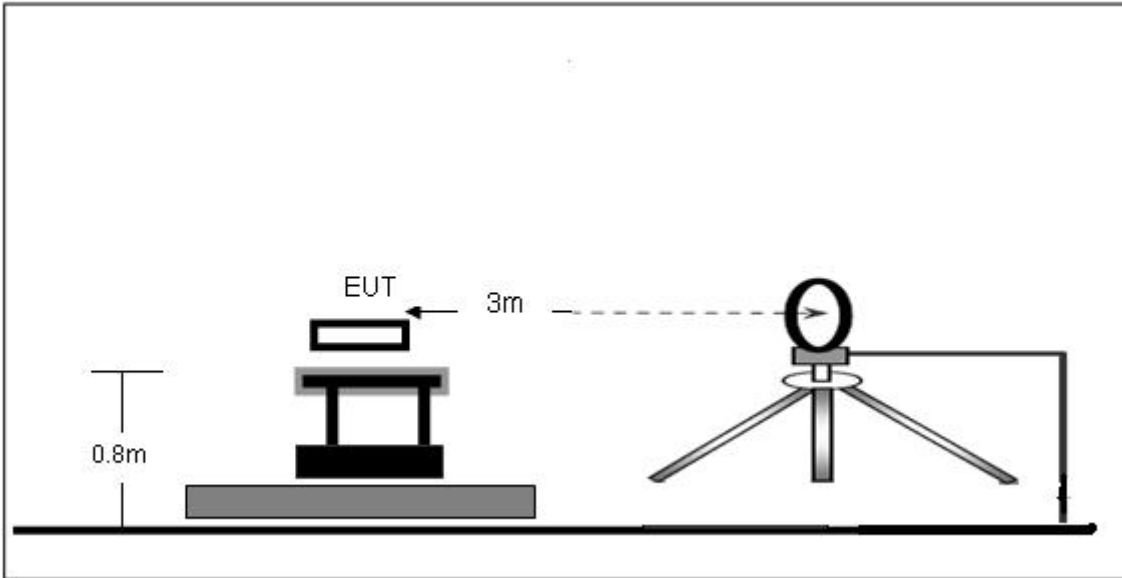

(B) Radiated Emission Test-Up Frequency 30MHz~1GHz

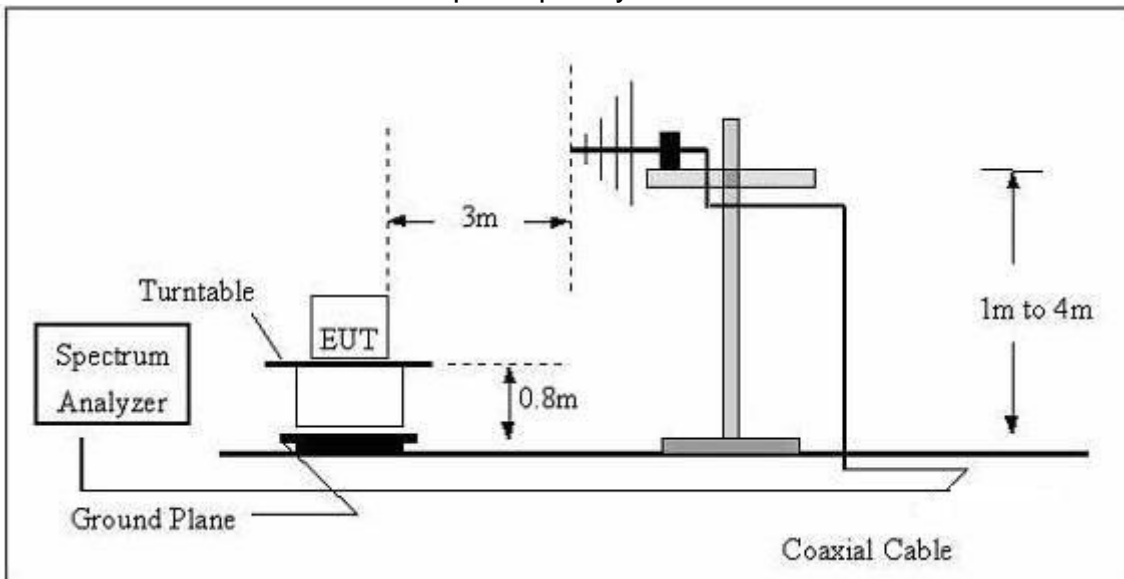

(C) Radiated Emission Test-Up Frequency Above 1GHz

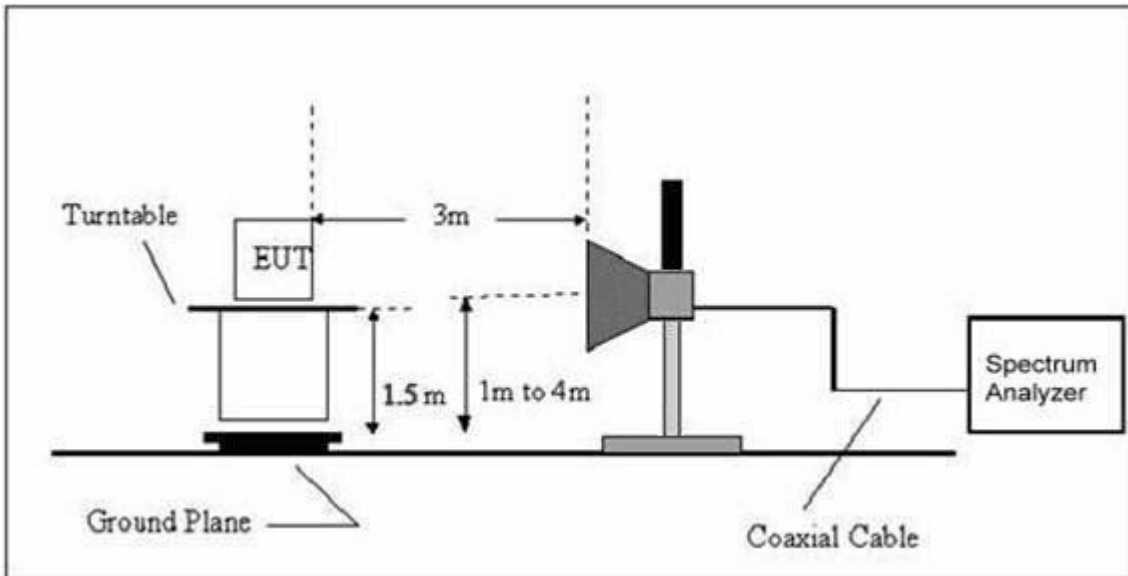

4.2.5. EUT OPERATING CONDITIONS

The EUT tested system was configured as the statements of 2.4 Unless otherwise a special operating condition is specified in the follows during the testing.

We pretest all adapter's emission, only the adapter 1's data was worst and the data was recording in the report.

The data only show the worst mode.



Radiated Spurious Emission (Below 30MHz)

EUT :	300Mbps Wifi Adapter	Model Name :	GWF-4B06
Temperature :	20 °C	Relative Humidity :	48%
Pressure :	1010 hPa	Polarization :	---
Test Voltage :	DC 5V from PC		
Test Mode :	TX		

Freq. (MHz)	Reading (dBuV/m)	Limit (dBuV/m)	Margin (dB)	State P/F
--	--	--	--	PASS
--	--	--	--	PASS

Note:

The amplitude of spurious emissions which are attenuated by more than 20dB below the permissible value has no need to be reported.

Distance extrapolation factor = $40 \log(\text{specific distance}/\text{test distance})$ (dB);

Limit line = specific limits(dBuv) + distance extrapolation factor.



Radiated Spurious Emission (Between 30MHz – 1GHz)

Temperature :	26 °C	Relative Humidity :	54%
Pressure :	1010 hPa	Polarization :	Horizontal
Test Voltage :	DC 5V from PC		
Test Mode : (Worst)	Link Mode		

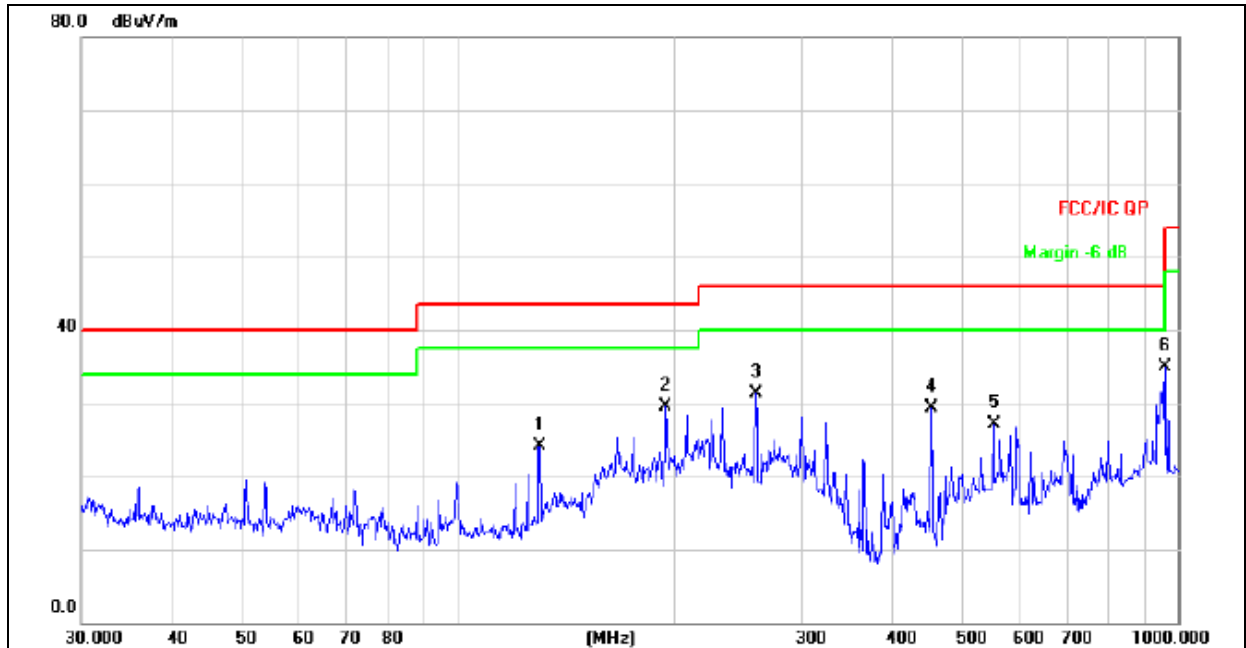

Remark:

Factor = Antenna Factor + Cable Loss – Pre-amplifier.
All interfaces was connected, and BT TX mode was link.

No.	Mk.	Freq.	Reading Level	Correct Factor	Measurement	Limit	Over	Antenna Height	Table Degree	
		MHz	dBuV	dB/m	dBuV/m	dBuV/m	dB	cm	degree	Comment
1		129.9226	38.25	-14.11	24.14	43.50	-19.36	QP		
2	*	194.4534	45.38	-15.86	29.52	43.50	-13.98	QP		
3		259.2338	45.17	-13.94	31.23	46.00	-14.77	QP		
4		454.3100	38.18	-8.95	29.23	46.00	-16.77	QP		
5		554.8254	34.02	-6.96	27.06	46.00	-18.94	QP		
6		962.1623	35.39	-0.42	34.97	54.00	-19.03	QP		



Temperature :	26 °C	Relative Humidity :	54%
Pressure :	1010 hPa	Polarization :	Vertical
Test Voltage :	DC 5V from PC		
Test Mode : (Worst)	Link Mode		

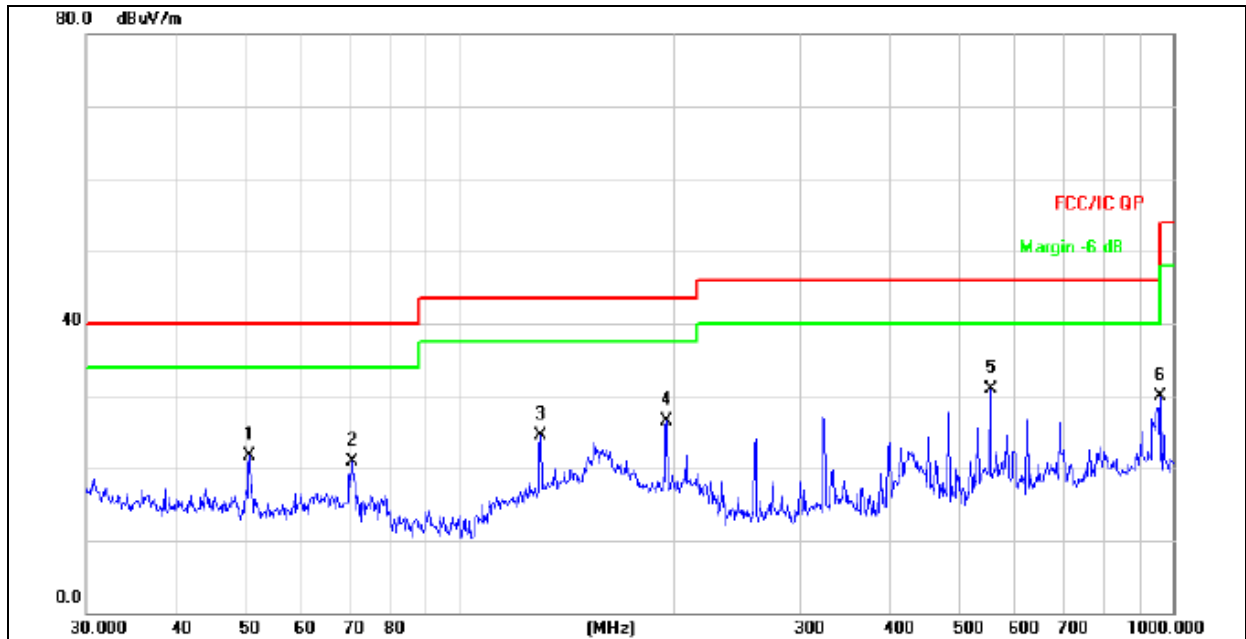

Remark:

Factor = Antenna Factor + Cable Loss – Pre-amplifier.

All interfaces was connected, and BT TX mode was link.

No.	Mk.	Freq.	Reading Level	Correct Factor	Measurement	Limit	Over	Antenna Height	Table Degree	
		MHz	dBuV	dB/m	dBuV/m	dBuV/m	dB	cm	degree	Comment
1		50.7637	32.19	-10.42	21.77	40.00	-18.23	QP		
2		70.5836	35.55	-14.74	20.81	40.00	-19.19	QP		
3		129.9226	38.63	-14.11	24.52	43.50	-18.98	QP		
4		195.1365	42.32	-15.90	26.42	43.50	-17.08	QP		
5	*	554.8254	37.78	-6.96	30.82	46.00	-15.18	QP		
6		962.1623	30.36	-0.42	29.94	54.00	-24.06	QP		



Radiated Spurious Emission (1GHz to 5th harmonics)

802.11a band 1

	Freq.	Receiver Reading	Detector	Polar	Pre-amplifier	Cable Loss	Antenna Factor	Emission Level	Limit	Result
	(MHz)	(dBμV)	(PK/QP/Ave)	(H/V)	(dB)	(dB)	(dB)	(dBμV/m)	(dBμV/m)	
Lower Channel 5180MHz	10360.00	57.82	PK	H	33.36	6.20	29.10	59.76	74.00	Pass
	10360.00	47.79	Ave	H	33.36	6.20	29.10	49.73	54.00	Pass
	15540.00	59.47	PK	H	34.40	6.55	26.50	58.12	74.00	Pass
	15540.00	48.76	Ave	H	34.40	6.55	26.50	47.41	54.00	Pass
	10360.00	57.67	PK	V	33.36	6.20	29.10	59.61	74.00	Pass
	10360.00	48.61	Ave	V	33.45	6.20	29.10	50.46	54.00	Pass
	15540.00	58.89	PK	V	34.40	6.55	26.50	57.54	74.00	Pass
	15540.00	48.97	Ave	V	34.40	6.55	26.50	47.62	54.00	Pass
	Middle Channel 5200MHz	10400.00	56.52	PK	H	33.65	6.45	29.36	58.68	74.00
10400.00		47.53	Ave	H	33.65	6.45	29.36	49.69	54.00	Pass
15600.00		59.03	PK	H	34.72	6.84	26.68	57.83	74.00	Pass
15600.00		47.54	Ave	H	34.72	6.84	26.68	46.34	54.00	Pass
10400.00		57.32	PK	V	33.65	6.45	29.36	59.48	74.00	Pass
10400.00		48.51	Ave	V	33.65	6.45	29.36	50.67	54.00	Pass
15600.00		58.78	PK	V	34.72	6.84	26.68	57.58	74.00	Pass
15600.00		47.83	Ave	V	34.72	6.84	26.38	46.33	54.00	Pass
Upper Channel 5240MHz	10480.00	56.7	PK	H	33.89	6.82	30.55	60.18	74.00	Pass
	10480.00	46.35	Ave	H	33.89	6.82	30.55	49.83	54.00	Pass
	15720.00	58.95	PK	H	35.12	6.95	27.85	58.63	74.00	Pass
	15720.00	47.84	Ave	H	35.12	6.95	27.85	47.52	54.00	Pass
	10480.00	57.71	PK	V	33.89	6.82	30.55	61.19	74.00	Pass
	10480.00	47.16	Ave	V	33.89	6.82	30.55	50.64	54.00	Pass
	15720.00	59.06	PK	V	35.12	6.95	27.85	58.74	74.00	Pass
	15720.00	47.99	Ave	V	35.12	6.95	27.85	47.67	54.00	Pass

Remark:

Emission Level = Antenna Factor + Cable Loss – Pre-amplifier.

Margin = Emission Level - Limit

Other harmonics emissions are lower than 20dB below the allowable limit.



802.11a band 4

	Freq.	Receiver Reading	Detector	Polar	Pre-amplifier	Cable Loss	Antenna Factor	Emission Level	Limit	Result
	(MHz)	(dBμV)	(PK/QP/Ave)	(H/V)	(dB)	(dB)	(dB)	(dBμV/m)	(dBμV/m)	
Lower Channel 5745MHz	11490.00	56.84	PK	H	34.25	6.48	29.46	58.53	74.00	Pass
	11490.00	47.81	Ave	H	33.25	6.48	29.46	50.5	54.00	Pass
	17235.00	58.52	PK	H	34.83	6.96	26.88	57.53	74.00	Pass
	17235.00	47.75	Ave	H	34.83	6.96	26.88	46.76	54.00	Pass
	11490.00	56.5	PK	V	34.25	6.48	29.46	58.19	74.00	Pass
	11490.00	47.64	Ave	V	33.25	6.48	29.46	50.33	54.00	Pass
	17235.00	58.76	PK	V	34.83	6.96	26.88	57.77	74.00	Pass
	17235.00	47.95	Ave	V	34.83	6.96	26.88	46.96	54.00	Pass
	Middle Channel 5785MHz	11570.00	57.51	PK	H	33.95	6.89	29.36	59.81	74.00
11570.00		48.05	Ave	H	33.95	6.89	29.36	50.35	54.00	Pass
17355.00		58.12	PK	H	35.25	7.10	27.22	57.19	74.00	Pass
17355.00		48.52	Ave	H	35.25	7.10	27.22	47.59	54.00	Pass
11570.00		57.44	PK	V	33.95	6.89	29.36	59.74	74.00	Pass
11570.00		47.83	Ave	V	33.95	6.89	29.36	50.13	54.00	Pass
17355.00		59.01	PK	V	35.25	7.10	27.22	58.08	74.00	Pass
17355.00		47.57	Ave	V	35.25	7.10	27.22	46.64	54.00	Pass
Upper Channel 5825MHz	11650.00	57.12	PK	H	34.35	7.15	30.15	60.07	57.12	Pass
	11650.00	46.04	Ave	H	34.35	7.15	30.15	48.99	46.04	Pass
	17475.00	59.77	PK	H	35.75	7.45	28.54	60.01	59.77	Pass
	17475.00	48.12	Ave	H	35.75	7.45	28.54	48.36	48.12	Pass
	11650.00	58.43	PK	V	34.35	7.15	30.15	61.38	58.43	Pass
	11650.00	46.91	Ave	V	34.35	7.15	30.15	49.86	46.91	Pass
	17475.00	59.21	PK	V	35.75	7.45	28.54	59.45	59.21	Pass
	17475.00	48.24	Ave	V	35.75	7.45	28.54	48.48	48.24	Pass

Remark:

Emission Level = Receiver Reading + Antenna Factor + Cable Loss – Pre-amplifier.

Margin = Emission Level - Limit

Other harmonics emissions are lower than 20dB below the allowable limit.



802.11n20 band 1

	Freq.	Receiver Reading	Detector	Polar	Pre-amplifier	Cable Loss	Antenna Factor	Emission Level	Limit	Result
	(MHz)	(dBμV)	(PK/QP/Ave)	(H/V)	(dB)	(dB)	(dB)	(dBμV/m)	(dBμV/m)	
Lower Channel 5180MHz	10360.00	57.81	PK	H	33.36	6.20	29.10	59.75	74.00	Pass
	10360.00	47.78	Ave	H	33.36	6.20	29.10	49.72	54.00	Pass
	15540.00	59.46	PK	H	34.40	6.55	26.50	58.11	74.00	Pass
	15540.00	48.75	Ave	H	34.40	6.55	26.50	47.40	54.00	Pass
	10360.00	57.65	PK	V	33.36	6.20	29.10	59.59	74.00	Pass
	10360.00	48.05	Ave	V	33.45	6.20	29.10	49.90	54.00	Pass
	15540.00	58.87	PK	V	34.40	6.55	26.50	57.52	74.00	Pass
	15540.00	48.96	Ave	V	34.40	6.55	26.50	47.61	54.00	Pass
	Middle Channel 5200MHz	10400.00	56.50	PK	H	33.65	6.45	29.36	58.66	74.00
10400.00		47.52	Ave	H	33.65	6.45	29.36	49.68	54.00	Pass
15600.00		59.01	PK	H	34.72	6.84	26.68	57.81	74.00	Pass
15600.00		47.53	Ave	H	34.72	6.84	26.68	46.33	54.00	Pass
10400.00		57.31	PK	V	33.65	6.45	29.36	59.47	74.00	Pass
10400.00		47.76	Ave	V	33.65	6.45	29.36	49.92	54.00	Pass
15600.00		58.77	PK	V	34.72	6.84	26.68	57.57	74.00	Pass
15600.00		47.82	Ave	V	34.72	6.84	26.38	46.32	54.00	Pass
Upper Channel 5240MHz	10480.00	56.69	PK	H	33.89	6.82	30.55	60.17	74.00	Pass
	10480.00	46.94	Ave	H	33.89	6.82	30.55	50.42	54.00	Pass
	15720.00	59.00	PK	H	35.12	6.95	27.85	58.68	74.00	Pass
	15720.00	47.83	Ave	H	35.12	6.95	27.85	47.51	54.00	Pass
	10480.00	57.69	PK	V	33.89	6.82	30.55	61.17	74.00	Pass
	10480.00	45.85	Ave	V	33.89	6.82	30.55	49.33	54.00	Pass
	15720.00	59.05	PK	V	35.12	6.95	27.85	58.73	74.00	Pass
	15720.00	47.98	Ave	V	35.12	6.95	27.85	47.66	54.00	Pass

Remark:

Emission Level = Antenna Factor + Cable Loss – Pre-amplifier.

Margin = Emission Level - Limit

Other harmonics emissions are lower than 20dB below the allowable limit.



802.11n20 band 4

	Freq.	Receiver Reading	Detector	Polar	Pre-amplifier	Cable Loss	Antenna Factor	Emission Level	Limit	Result
	(MHz)	(dBμV)	(PK/QP/Ave)	(H/V)	(dB)	(dB)	(dB)	(dBμV/m)	(dBμV/m)	
Lower Channel 5745MHz	11490.00	56.97	PK	H	34.26	6.45	29.23	58.39	74.00	Pass
	11490.00	47.47	Ave	H	33.26	6.45	29.23	49.89	54.00	Pass
	17235.00	58.68	PK	H	34.83	6.96	26.88	57.69	74.00	Pass
	17235.00	47.88	Ave	H	34.83	6.96	26.88	46.89	54.00	Pass
	11490.00	56.65	PK	V	34.25	6.48	29.46	58.34	74.00	Pass
	11490.00	46.35	Ave	V	33.25	6.48	29.46	49.04	54.00	Pass
	17235.00	58.92	PK	V	34.83	6.96	26.88	57.93	74.00	Pass
	17235.00	48.07	Ave	V	34.83	6.96	26.88	47.08	54.00	Pass
	Middle Channel 5785MHz	11570.00	57.67	PK	H	33.95	6.89	29.36	59.97	74.00
11570.00		46.91	Ave	H	33.95	6.89	29.36	49.21	54.00	Pass
17355.00		58.28	PK	H	35.25	7.10	27.22	57.35	74.00	Pass
17355.00		48.65	Ave	H	35.25	7.10	27.22	47.72	54.00	Pass
11570.00		57.6	PK	V	33.95	6.89	29.36	59.9	74.00	Pass
11570.00		47.46	Ave	V	33.95	6.89	29.36	49.76	54.00	Pass
17355.00		59.17	PK	V	35.25	7.10	27.22	58.24	74.00	Pass
17355.00		47.7	Ave	V	35.25	7.10	27.22	46.77	54.00	Pass
Upper Channel 5825MHz	11650.00	58.26	PK	H	34.35	7.15	30.15	61.21	57.12	Pass
	11650.00	46.84	Ave	H	34.35	7.15	30.15	49.79	46.04	Pass
	17475.00	59.93	PK	H	35.75	7.45	28.54	60.17	59.77	Pass
	17475.00	48.12	Ave	H	35.75	7.45	28.54	48.36	48.12	Pass
	11650.00	58.56	PK	V	34.35	7.15	30.15	61.51	58.43	Pass
	11650.00	47.02	Ave	V	34.35	7.15	30.15	49.97	46.91	Pass
	17475.00	59.37	PK	V	35.75	7.45	28.54	59.61	59.21	Pass
	17475.00	48.37	Ave	V	35.75	7.45	28.54	48.61	48.24	Pass

Remark:

Emission Level = Antenna Factor + Cable Loss – Pre-amplifier.

Margin = Emission Level - Limit

Other harmonics emissions are lower than 20dB below the allowable limit.



18G~40GHz

802.11a band 1

	Freq.	Receiver Reading	Detector	Polar	Pre-amplifier	Cable Loss	Antenna Factor	Emission Level	Limit	Result
	(MHz)	(dBμV)	(PK/QP/Ave)	(H/V)	(dB)	(dB)	(dB)	(dBμV/m)	(dBμV/m)	
Lower Channel 5180MHz	20590.00	58.81	PK	H	36.36	10.20	27.10	59.75	74.00	Pass
	20590.00	48.78	Ave	H	36.36	10.20	27.10	49.72	54.00	Pass
	25580.00	59.46	PK	H	36.40	10.55	27.50	61.11	74.00	Pass
	25590.00	48.56	Ave	H	36.40	10.55	27.50	50.21	54.00	Pass
	20590.00	57.45	PK	V	36.63	10.20	27.10	58.12	74.00	Pass
	20590.00	48.35	Ave	V	36.63	10.20	27.10	49.02	54.00	Pass
	25580.00	58.43	PK	V	36.40	10.55	27.50	60.08	74.00	Pass
	25580.00	47.96	Ave	V	36.40	10.55	27.50	49.61	54.00	Pass
	Middle Channel 5200MHz	20450.00	55.50	PK	H	36.38	10.20	27.10	56.42	74.00
20450.00		46.52	Ave	H	36.38	10.20	27.10	47.44	54.00	Pass
25670.00		58.01	PK	H	36.45	10.55	27.50	59.61	74.00	Pass
25670.00		46.53	Ave	H	36.45	10.55	27.50	48.13	54.00	Pass
20450.00		57.31	PK	V	36.68	10.20	27.10	57.93	74.00	Pass
20450.00		47.35	Ave	V	36.68	10.20	27.10	47.97	54.00	Pass
25670.00		58.12	PK	V	36.50	10.55	27.50	59.67	74.00	Pass
25670.00		47.76	Ave	V	36.50	10.55	27.50	49.31	54.00	Pass
Upper Channel 5240MHz	20480.00	56.64	PK	H	36.65	10.35	27.34	57.68	74.00	Pass
	20480.00	46.54	Ave	H	36.65	10.35	27.34	47.58	54.00	Pass
	25720.00	58.56	PK	H	36.74	10.78	27.95	60.55	74.00	Pass
	25720.00	47.75	Ave	H	36.74	10.78	27.95	49.74	54.00	Pass
	20480.00	57.25	PK	V	36.65	10.35	27.34	58.29	74.00	Pass
	20480.00	45.75	Ave	V	36.65	10.35	27.34	46.79	54.00	Pass
	25785.00	59.21	PK	V	36.74	10.78	27.95	61.2	74.00	Pass
	25785.00	47.68	Ave	V	36.74	10.78	27.95	49.67	54.00	Pass

Remark:

Emission Level = Antenna Factor + Cable Loss – Pre-amplifier.

Margin = Emission Level - Limit

Other harmonics emissions are lower than 20dB below the allowable limit.



802.11a band 4

	Freq.	Receiver Reading	Detector	Polar	Pre-amplifier	Cable Loss	Antenna Factor	Emission Level	Limit	Result
	(MHz)	(dBμV)	(PK/QP/Ave)	(H/V)	(dB)	(dB)	(dB)	(dBμV/m)	(dBμV/m)	
Lower Channel 5745MHz	214560.00	56.85	PK	H	37.15	10.55	28.12	58.37	74.00	Pass
	21456.00	47.56	Ave	H	37.15	10.55	28.12	49.08	54.00	Pass
	27235.00	58.62	PK	H	37.44	10.84	28.43	60.45	74.00	Pass
	27235.00	47.48	Ave	H	37.44	10.84	28.43	49.31	54.00	Pass
	214560.00	56.45	PK	V	37.15	10.55	28.12	57.97	74.00	Pass
	21456.00	46.25	Ave	V	37.15	10.55	28.12	47.77	54.00	Pass
	27235.00	57.92	PK	V	37.44	10.84	28.43	59.75	74.00	Pass
	27235.00	47.62	Ave	V	37.44	10.84	28.43	49.45	54.00	Pass
	Middle Channel 5785MHz	21548.00	57.27	PK	H	37.15	10.89	28.35	59.36	74.00
21548.00		46.84	Ave	H	37.15	10.89	28.35	48.93	54.00	Pass
27395.00		58.19	PK	H	37.44	10.95	28.54	60.24	74.00	Pass
27395.00		48.52	Ave	H	37.44	10.95	28.54	50.57	54.00	Pass
21548.00		57.53	PK	V	37.15	10.89	28.35	59.62	74.00	Pass
21548.00		47.37	Ave	V	37.15	10.89	28.35	49.46	54.00	Pass
27395.00		59.21	PK	V	37.44	10.95	28.54	61.26	74.00	Pass
27395.00		47.18	Ave	V	37.44	10.95	28.54	49.23	54.00	Pass
Upper Channel 5825MHz	21750.00	57.86	PK	H	37.29	10.96	28.56	60.09	74.00	Pass
	21750.00	46.65	Ave	H	37.29	10.96	28.56	48.88	54.00	Pass
	27494.00	59.44	PK	H	37.65	11.15	28.75	61.69	74.00	Pass
	27494.00	47.55	Ave	H	37.65	11.15	28.75	49.8	54.00	Pass
	21750.00	58.39	PK	V	37.29	10.96	28.56	60.62	74.00	Pass
	21750.00	47.11	Ave	V	37.29	10.96	28.56	49.34	54.00	Pass
	27494.00	59.74	PK	V	37.65	11.15	28.75	61.99	74.00	Pass
	27494.00	47.56	Ave	V	37.65	11.15	28.75	49.81	54.00	Pass

Remark:

Emission Level = Receiver Reading + Antenna Factor + Cable Loss – Pre-amplifier.

Margin = Emission Level - Limit

Other harmonics emissions are lower than 20dB below the allowable limit.



802.11n20 band 1

	Freq.	Receiver Reading	Detector	Polar	Pre-amplifier	Cable Loss	Antenna Factor	Emission Level	Limit	Result
	(MHz)	(dBμV)	(PK/QP/Ave)	(H/V)	(dB)	(dB)	(dB)	(dBμV/m)	(dBμV/m)	
Lower Channel 5180MHz	20590.00	58.67	PK	H	36.36	10.20	27.10	59.61	74.00	Pass
	20590.00	48.45	Ave	H	36.36	10.20	27.10	49.39	54.00	Pass
	25580.00	59.61	PK	H	36.40	10.55	27.50	61.26	74.00	Pass
	25590.00	48.49	Ave	H	36.40	10.55	27.50	50.14	54.00	Pass
	20590.00	57.57	PK	V	36.63	10.20	27.10	58.24	74.00	Pass
	20590.00	48.85	Ave	V	36.63	10.20	27.10	49.52	54.00	Pass
	25580.00	58.45	PK	V	36.40	10.55	27.50	60.10	74.00	Pass
	25580.00	47.23	Ave	V	36.40	10.55	27.50	48.88	54.00	Pass
	Middle Channel 5200MHz	20450.00	56.87	PK	H	36.38	10.20	27.10	57.79	74.00
20450.00		45.63	Ave	H	36.38	10.20	27.10	46.55	54.00	Pass
25670.00		58.22	PK	H	36.45	10.55	27.50	59.82	74.00	Pass
25670.00		45.95	Ave	H	36.45	10.55	27.50	47.55	54.00	Pass
20450.00		57.46	PK	V	36.68	10.20	27.10	58.08	74.00	Pass
20450.00		47.75	Ave	V	36.68	10.20	27.10	48.37	54.00	Pass
25670.00		58.69	PK	V	36.50	10.55	27.50	60.24	74.00	Pass
25670.00		47.48	Ave	V	36.50	10.55	27.50	49.03	54.00	Pass
Upper Channel 5240MHz	20480.00	56.25	PK	H	36.65	10.35	27.34	57.29	74.00	Pass
	20480.00	46.37	Ave	H	36.65	10.35	27.34	47.41	54.00	Pass
	25720.00	58.71	PK	H	36.74	10.78	27.95	60.7	74.00	Pass
	25720.00	47.48	Ave	H	36.74	10.78	27.95	49.47	54.00	Pass
	20480.00	57.19	PK	V	36.65	10.35	27.34	58.23	74.00	Pass
	20480.00	45.47	Ave	V	36.65	10.35	27.34	46.51	54.00	Pass
	25785.00	59.38	PK	V	36.74	10.78	27.95	61.37	74.00	Pass
	25785.00	47.44	Ave	V	36.74	10.78	27.95	49.43	54.00	Pass

Remark:

Emission Level = Antenna Factor + Cable Loss – Pre-amplifier.

Margin = Emission Level - Limit

Other harmonics emissions are lower than 20dB below the allowable limit.



802.11n20 band 4

	Freq.	Receiver Reading	Detector	Polar	Pre-amplifier	Cable Loss	Antenna Factor	Emission Level	Limit	Result
	(MHz)	(dBμV)	(PK/QP/Ave)	(H/V)	(dB)	(dB)	(dB)	(dBμV/m)	(dBμV/m)	
Lower Channel 5745MHz	214560.00	56.37	PK	H	37.15	10.55	28.12	57.89	74.00	Pass
	21456.00	47.78	Ave	H	37.15	10.55	28.12	49.3	54.00	Pass
	27235.00	57.62	PK	H	37.44	10.84	28.43	59.45	74.00	Pass
	27235.00	46.48	Ave	H	37.44	10.84	28.43	48.31	54.00	Pass
	214560.00	56.22	PK	V	37.15	10.55	28.12	57.74	74.00	Pass
	21456.00	46.47	Ave	V	37.15	10.55	28.12	47.99	54.00	Pass
	27235.00	57.78	PK	V	37.44	10.84	28.43	59.61	74.00	Pass
	27235.00	47.12	Ave	V	37.44	10.84	28.43	48.95	54.00	Pass
	Middle Channel 5785MHz	21548.00	57.45	PK	H	37.15	10.89	28.35	59.54	74.00
21548.00		46.39	Ave	H	37.15	10.89	28.35	48.48	54.00	Pass
27395.00		58.48	PK	H	37.44	10.95	28.54	60.53	74.00	Pass
27395.00		48.29	Ave	H	37.44	10.95	28.54	50.34	54.00	Pass
21548.00		57.35	PK	V	37.15	10.89	28.35	59.44	74.00	Pass
21548.00		47.46	Ave	V	37.15	10.89	28.35	49.55	54.00	Pass
27395.00		59.57	PK	V	37.44	10.95	28.54	61.62	74.00	Pass
27395.00		47.33	Ave	V	37.44	10.95	28.54	49.38	54.00	Pass
Upper Channel 5825MHz	21750.00	57.78	PK	H	37.29	10.96	28.56	60.01	74.00	Pass
	21750.00	46.21	Ave	H	37.29	10.96	28.56	48.44	54.00	Pass
	27494.00	59.44	PK	H	37.65	11.15	28.75	61.69	74.00	Pass
	27494.00	47.51	Ave	H	37.65	11.15	28.75	49.76	54.00	Pass
	21750.00	58.35	PK	V	37.29	10.96	28.56	60.58	74.00	Pass
	21750.00	47.22	Ave	V	37.29	10.96	28.56	49.45	54.00	Pass
	27494.00	59.38	PK	V	37.65	11.15	28.75	61.63	74.00	Pass
	27494.00	47.14	Ave	V	37.65	11.15	28.75	49.39	54.00	Pass

Remark:

Emission Level = Antenna Factor + Cable Loss – Pre-amplifier.

Margin = Emission Level - Limit

Other harmonics emissions are lower than 20dB below the allowable limit.



802.11a band 1 5180MHz Horizontal

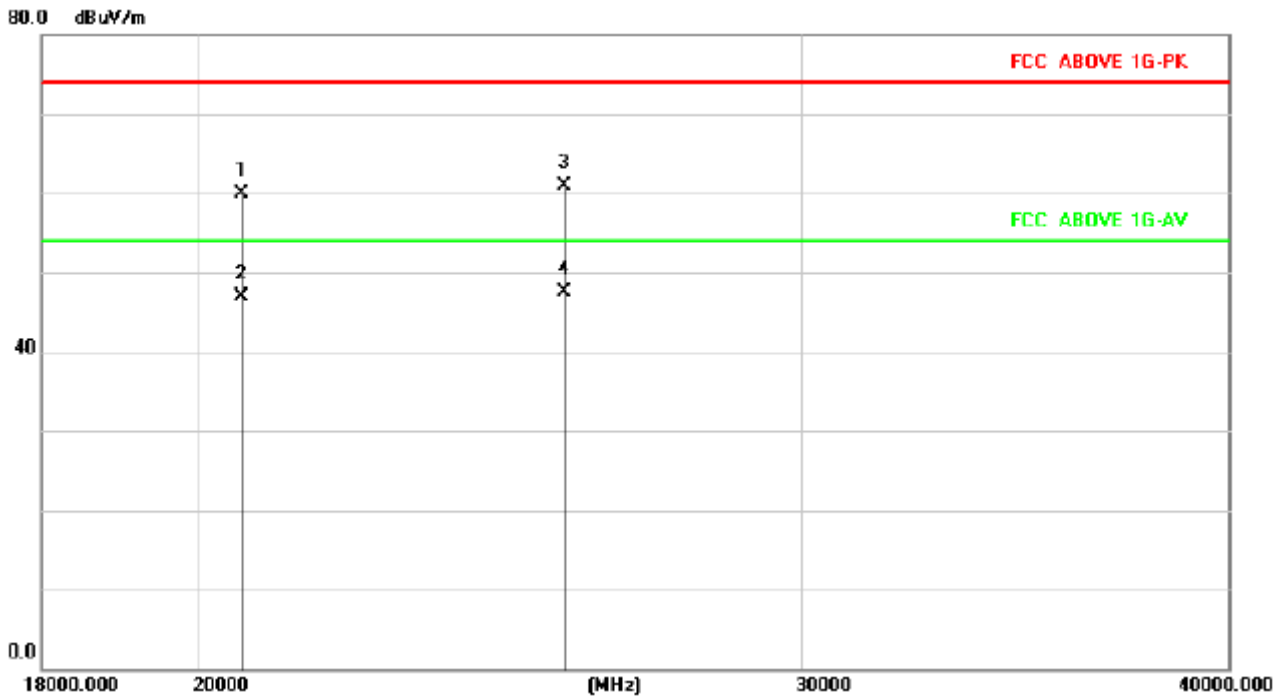

5180MHz Vertical

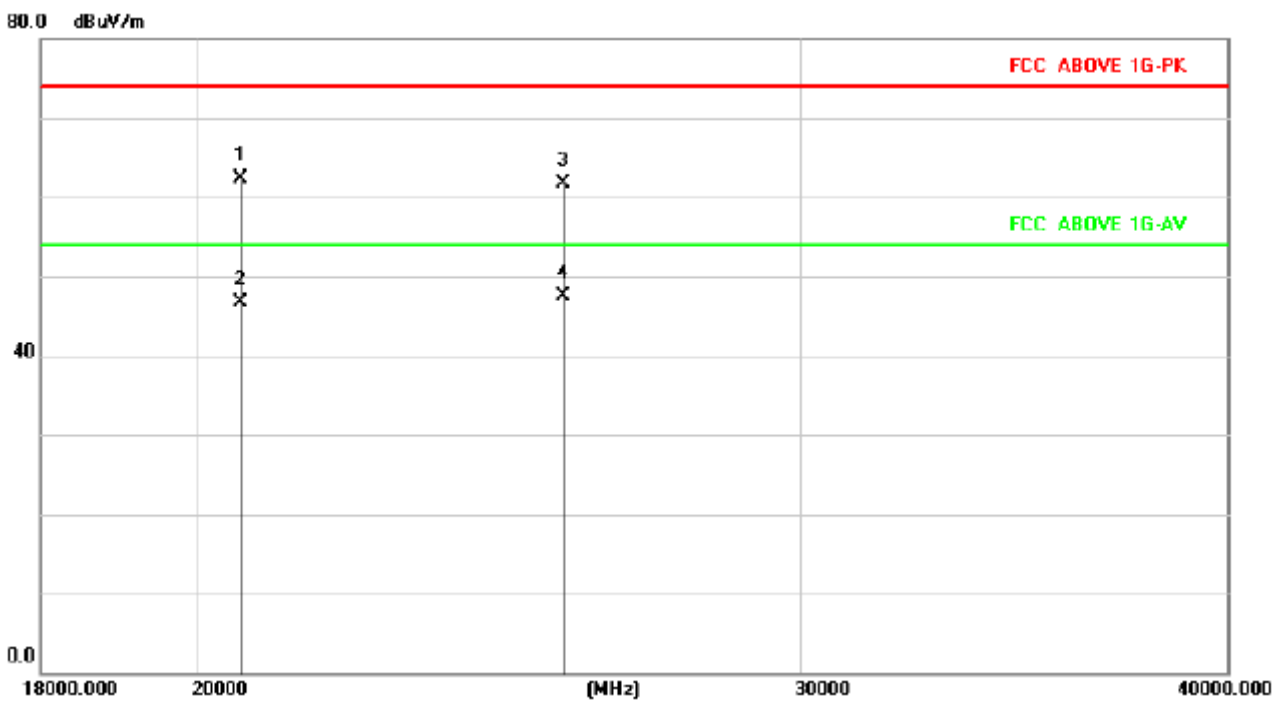



5200MHz Horizontal

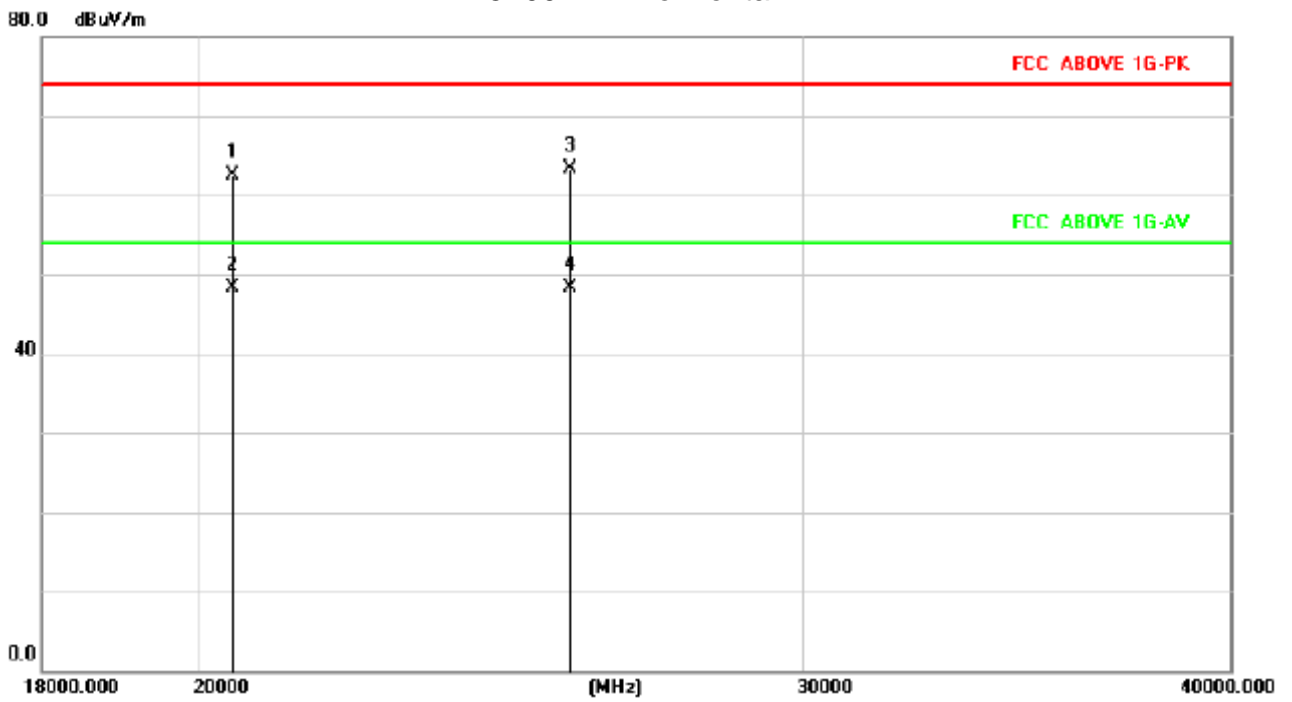

5200MHz Vertical

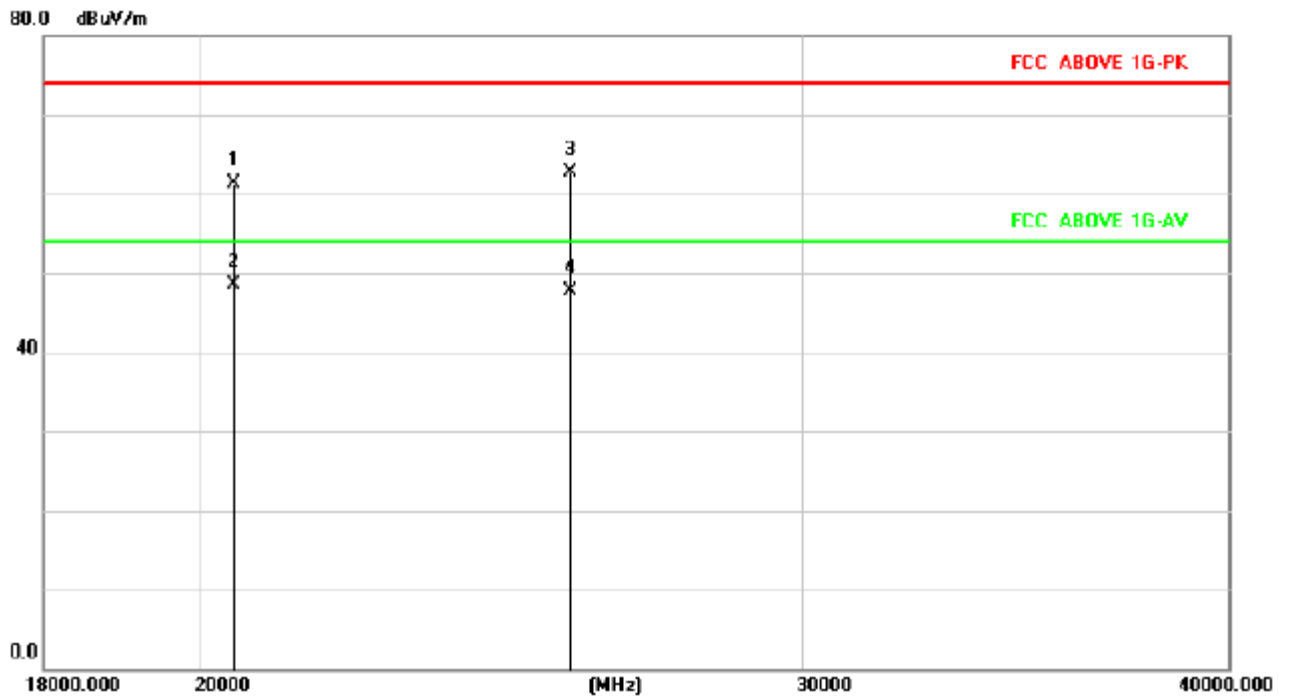



5240MHz Horizontal

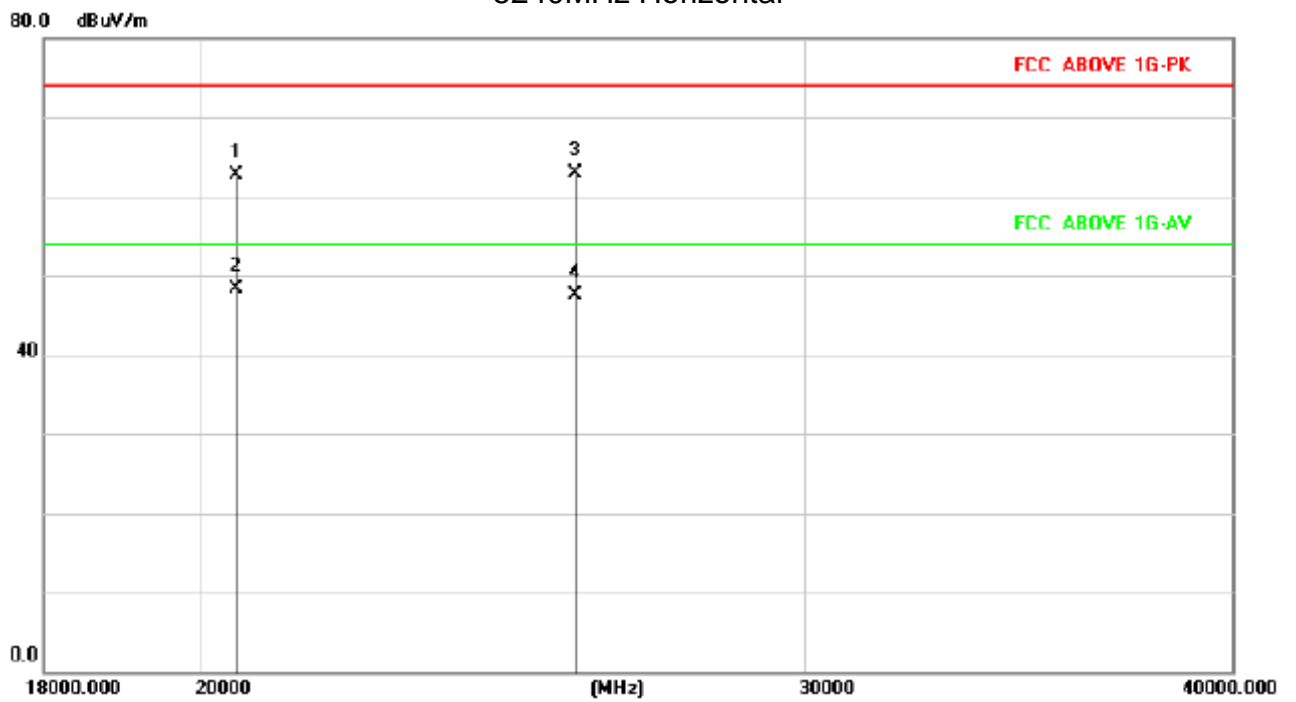

5240MHz Vertical

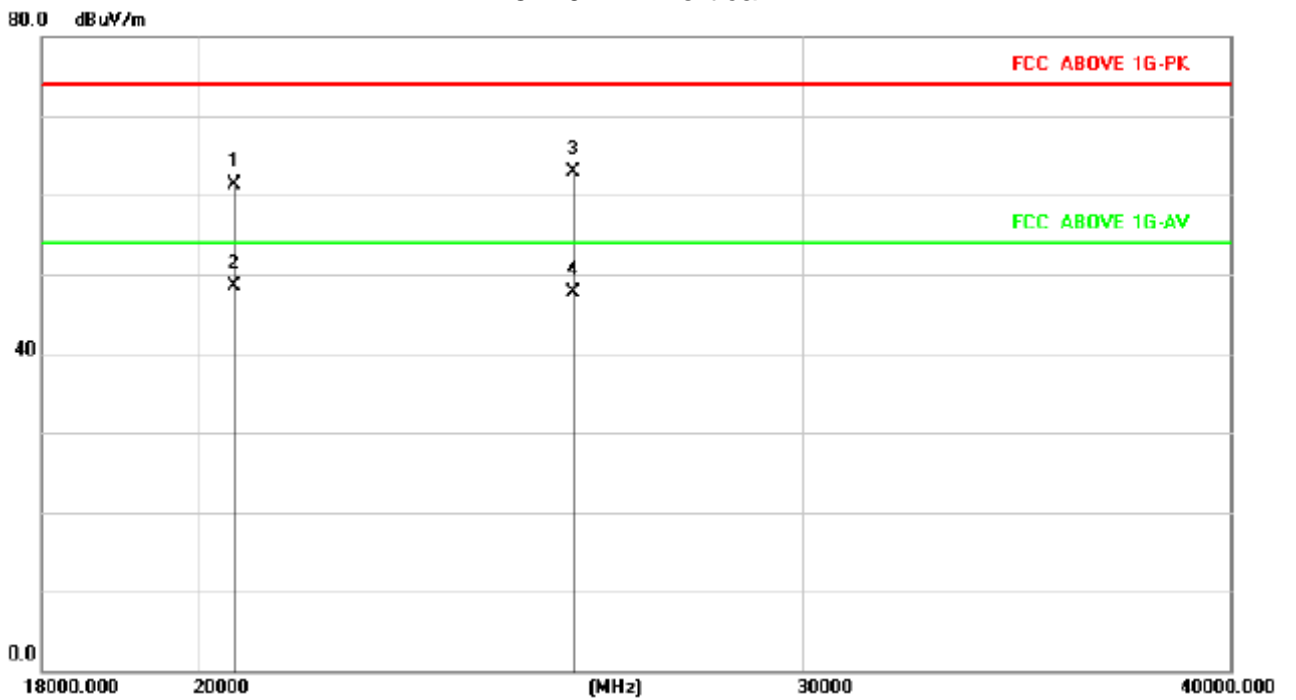

Note: "802.11a band 1" mode is the worst mode and the data recording in the report.



5. BAND EDGE COMPLIANCE TEST

5.1. Limits

(1) For transmitters operating in the 5.15-5.25 GHz band: All emissions outside of the 5.15-5.35 GHz band shall not exceed an e.i.r.p. of -27 dBm/MHz.

(4) For transmitters operating in the 5.725-5.85 GHz band: All emissions within the frequency range from the band edge to 10 MHz above or below the band edge shall not exceed an e.i.r.p. of -17 dBm/MHz; for frequencies 10 MHz or greater above or below the band edge, emissions shall not exceed an e.i.r.p. of -27 dBm/MHz.

5.2. Test setup

Test method: FCC KDB 789033 G)& Parts 15.407(b)(4) & 15.209(a)

Same as Clause 4.2.

5.3. Test Data

Please see data as below:

Note: we pretest horizontal and vertical, the worst was horizontal and show in the report.



Modulation	Test Frequency (MHz)	Max Level Frequency (MHz)	Max Level (dB μ V/m)	EIRP[dBm]	Limit[dBm]	Result
802.11a	5180	5148.63	52.46	-42.74	-27.00	Pass
	5240	5255.34	51.88	-43.32	-27.00	Pass
	5745	5723.67	51.64	-43.56	-27.00	Pass
	5825	5853.16	51.61	-43.59	-27.00	Pass
802.11n(HT20)	5180	5146.86	52.28	-42.92	-27.00	Pass
	5240	5253.19	52.16	-43.04	-27.00	Pass
	5745	5723.51	51.76	-43.44	-27.00	Pass
	5825	5853.43	52.09	-43.11	-27.00	Pass
802.11n(HT40)	5190	5147.69	51.87	-43.33	-27.00	Pass
	5230	5253.42	52.00	-43.20	-27.00	Pass
	5755	5723.11	51.54	-43.66	-27.00	Pass
	5795	5853.61	51.62	-43.58	-27.00	Pass

Remark: 1. According to KDB 789033 D02 section H) d) (iii), for measurement above 1000MHz@3m distance, the limit of EIRP is calculated as follows: $EIRP[dBm] = E[dB\mu V/m] - 95.2$



6. 26DB AND 99% BANDWIDTH TEST

6.1. Measurement Procedure

The bandwidth at 26 dB down from the highest in-band spectral density is measured with a spectrum analyzer connected to the antenna terminal while the EUT is operating at its maximum power control level, as defined in KDB 789033, at the appropriate frequencies. The spectrum analyzer's bandwidth measurement function is configured to measure the 26 dB bandwidth.

The 26 dB bandwidth is used to determine the conducted power limits.

There is no limit bandwidth for U-NII-1, U-NII-2-A and U-NII-2-C.

The minimum of 6dB Bandwidth measurement is 0.5 MHz for U-NII-3

we test all antennas, the antenna 1 was worst mode and the data recording in the report.



26dB bandwidth

	Frequency (MHz)	26dB Bandwidth (MHz)		99% Bandwidth (MHz)	
		Ant 1	Ant 2	Ant 1	Ant 2
802.11a	5180	18.796	19.805	16.483	16.454
	5200	18.965	18.614	16.487	16.471
	5240	18.662	18.834	16.450	16.450
802.11n (HT20)	5180	19.705	19.161	17.563	17.541
	5200	19.007	19.008	17.575	17.536
	5240	19.108	19.018	17.508	17.503
802.11n (HT40)	5190	38.779	38.726	35.982	35.920
	5230	38.468	38.627	35.905	35.904

	Frequency (MHz)	-6dB Bandwidth (MHz)		99% Bandwidth (MHz)		Limit (MHz)
		Ant 1	Ant 2	Ant 1	Ant 2	
802.11a	5745	16.31	16.31	16.411	16.416	>0.5
	5785	16.36	16.33	16.426	16.418	>0.5
	5825	16.34	16.30	16.407	16.413	>0.5
802.11n (HT20)	5745	17.03	17.05	17.559	17.558	>0.5
	5785	17.24	17.24	17.561	17.554	>0.5
	5825	16.98	16.97	17.560	17.557	>0.5
802.11n (HT40)	5755	35.20	35.20	35.852	35.861	>0.5
	5795	35.53	35.53	35.901	35.902	>0.5



802.11a 5180MHz

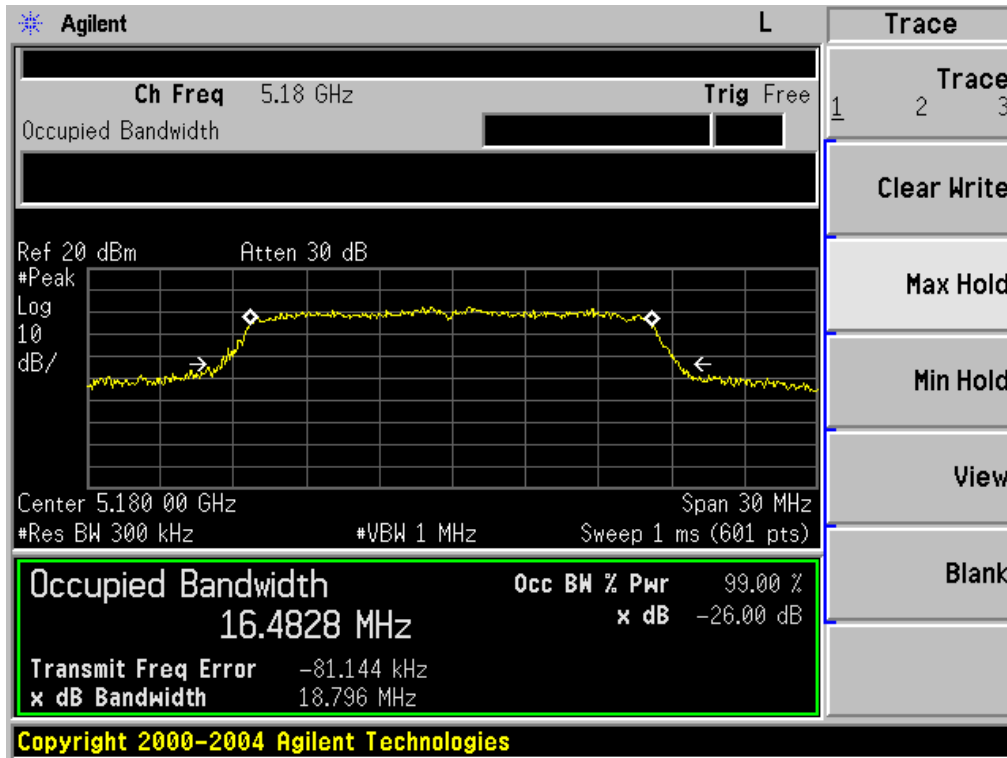

802.11a 5200MHz

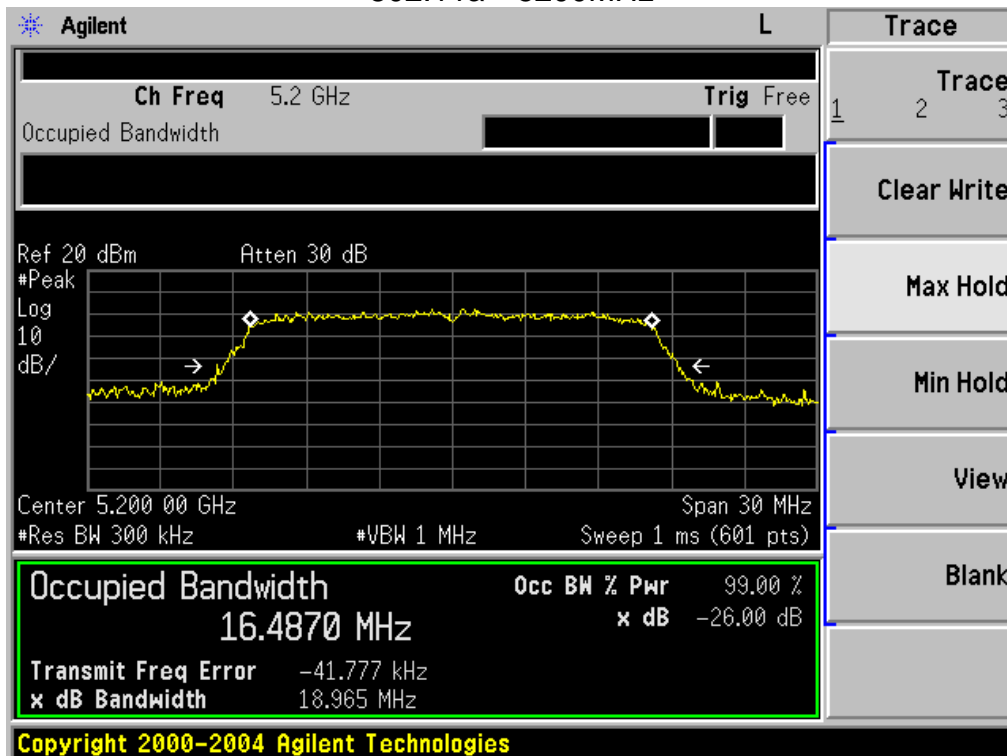



802.11a 5240MHz

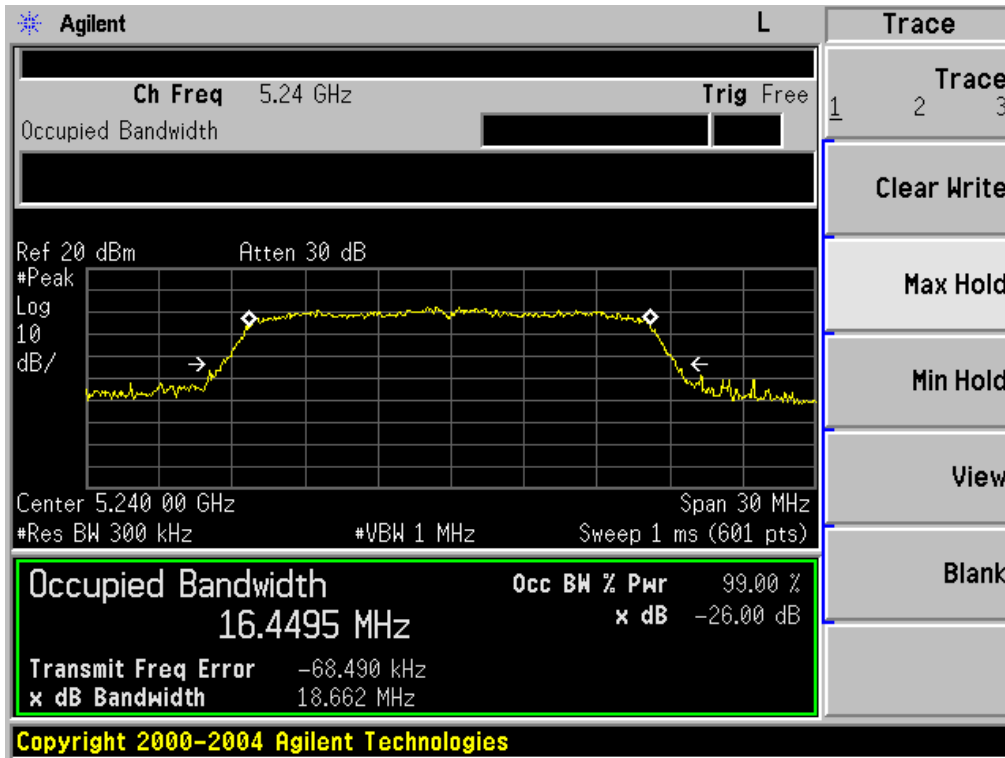

802.11n(HT20) 5180MHz

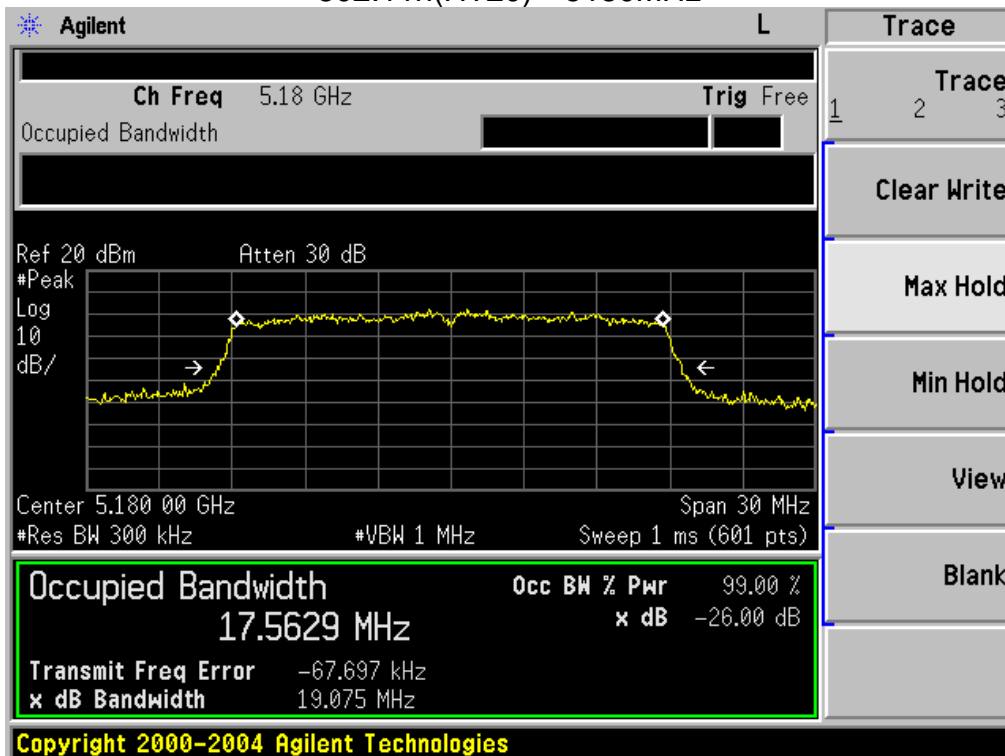



802.11n(HT20) 5200MHz

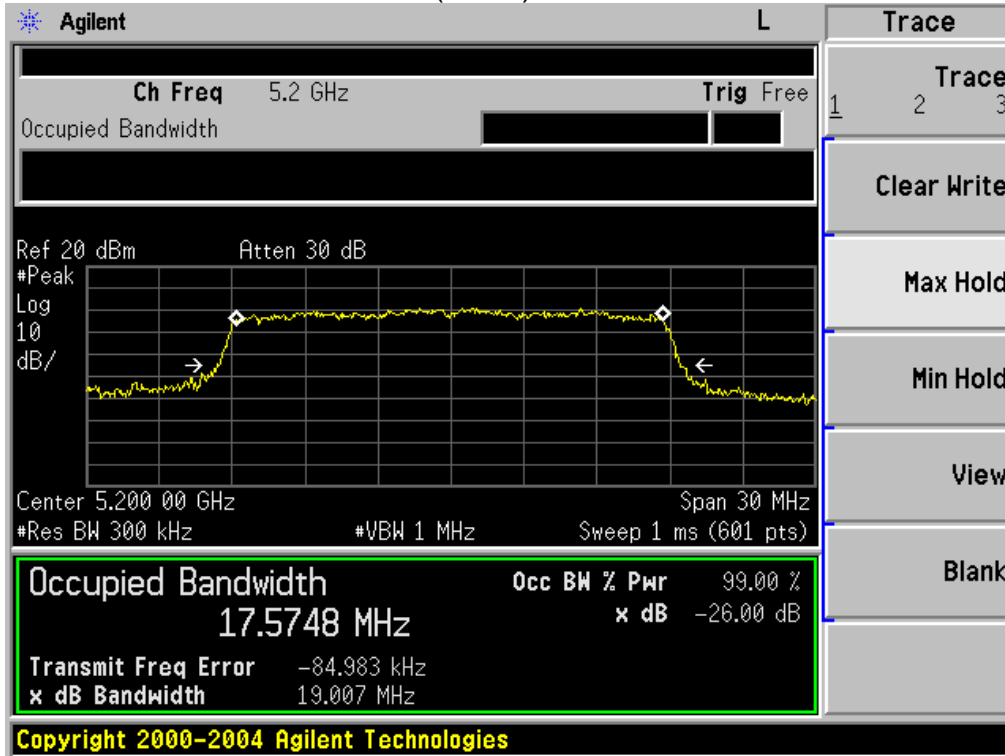

802.11n(HT20) 5240MHz

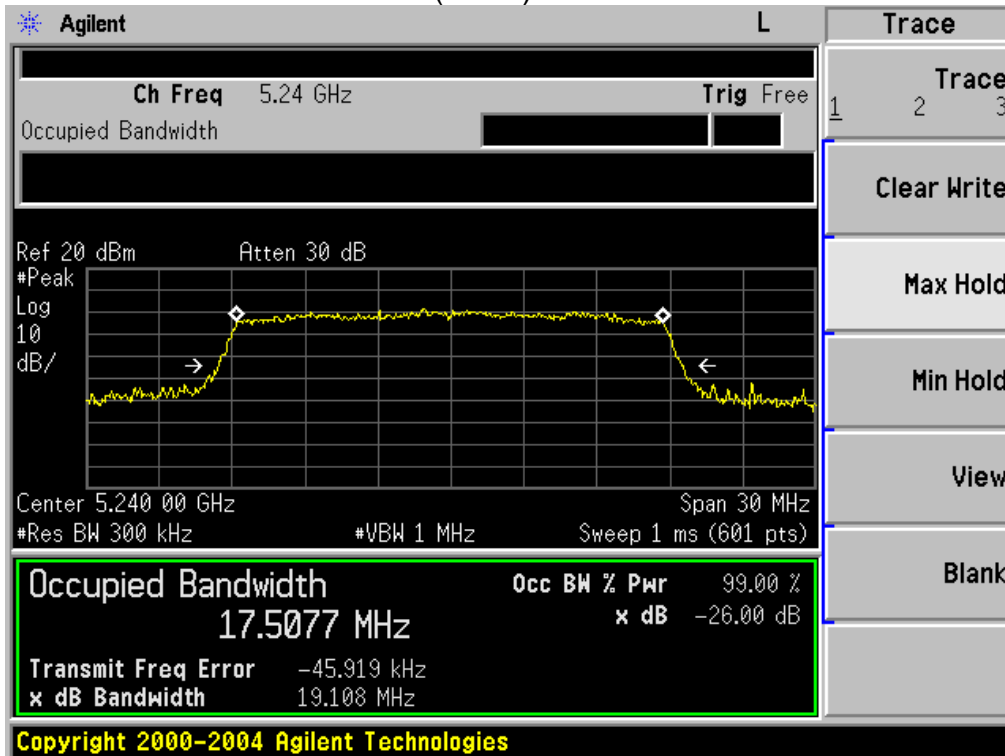



802.11n(HT40) 5190MHz

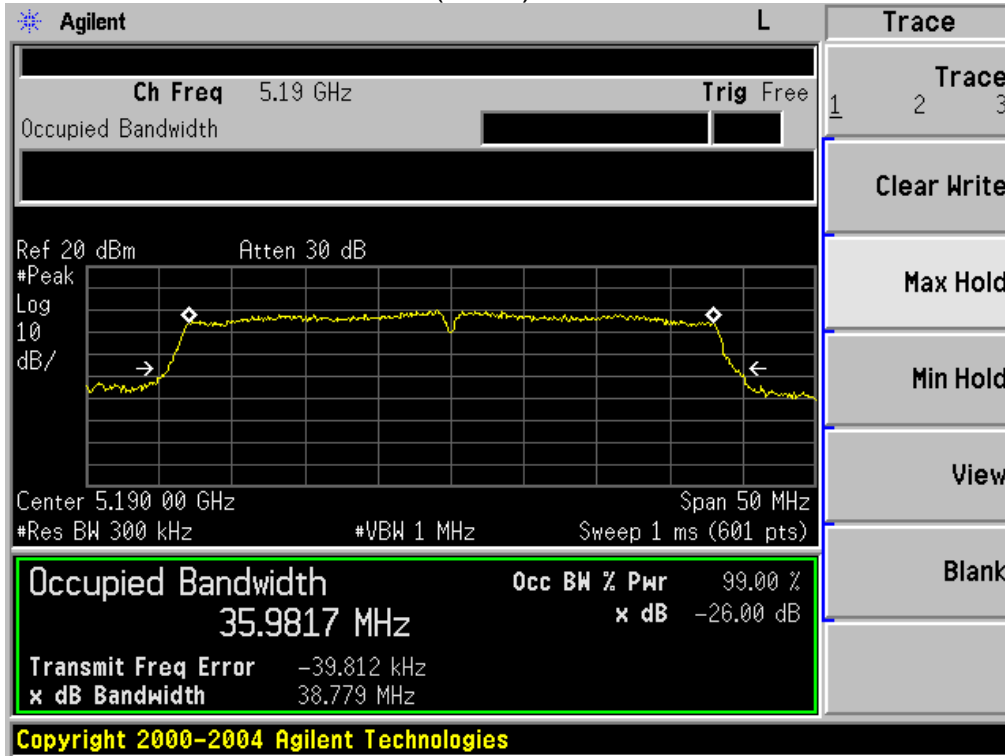

802.11n(HT40) 5230MHz

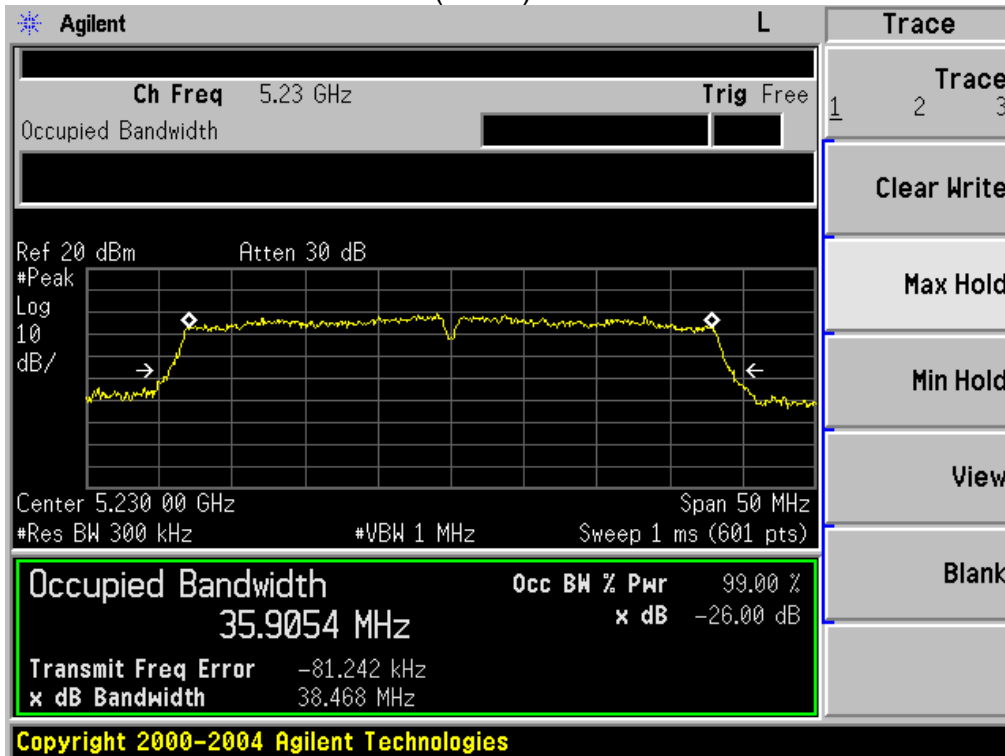



802.11a 5745MHz

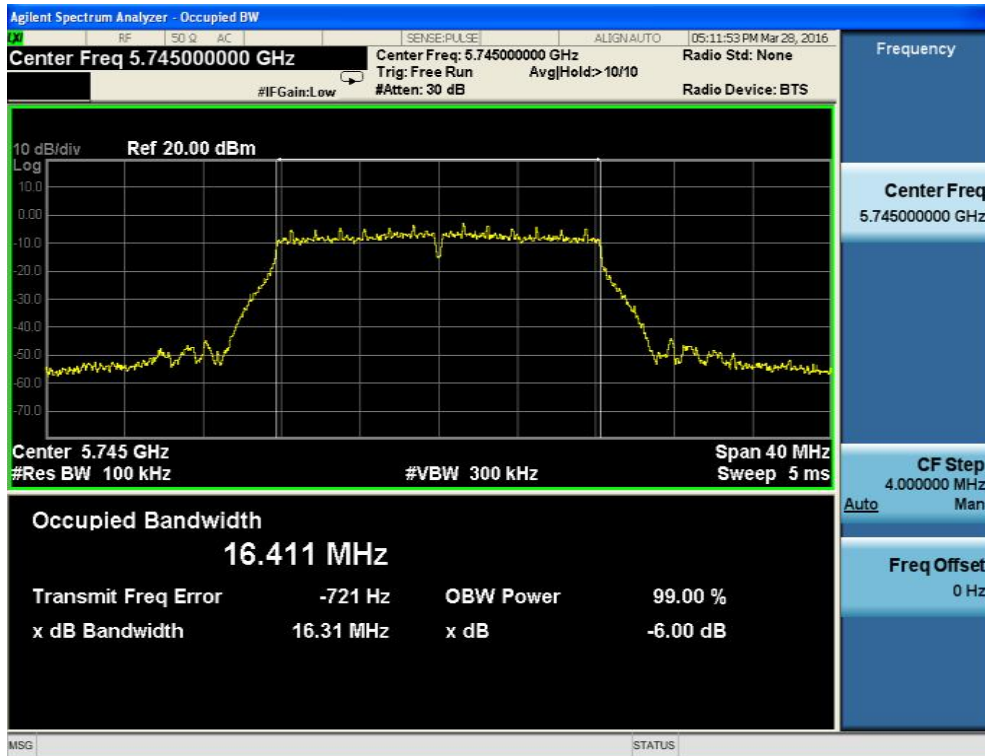

802.11a 5785MHz





802.11a 5825MHz

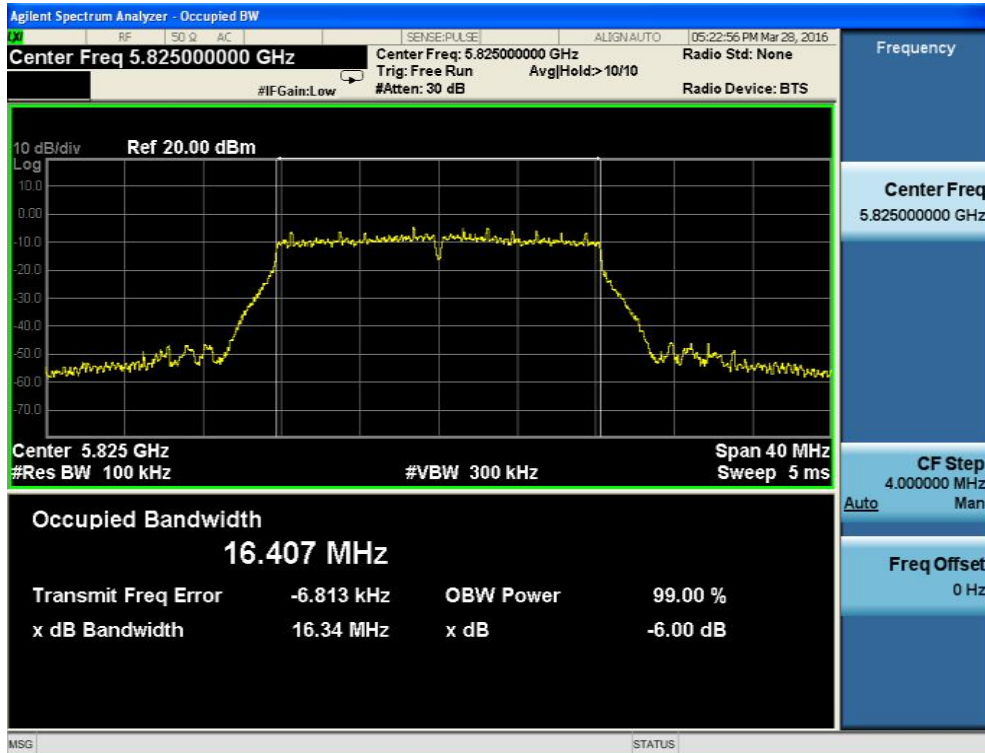

802.11n(HT20) 5745MHz

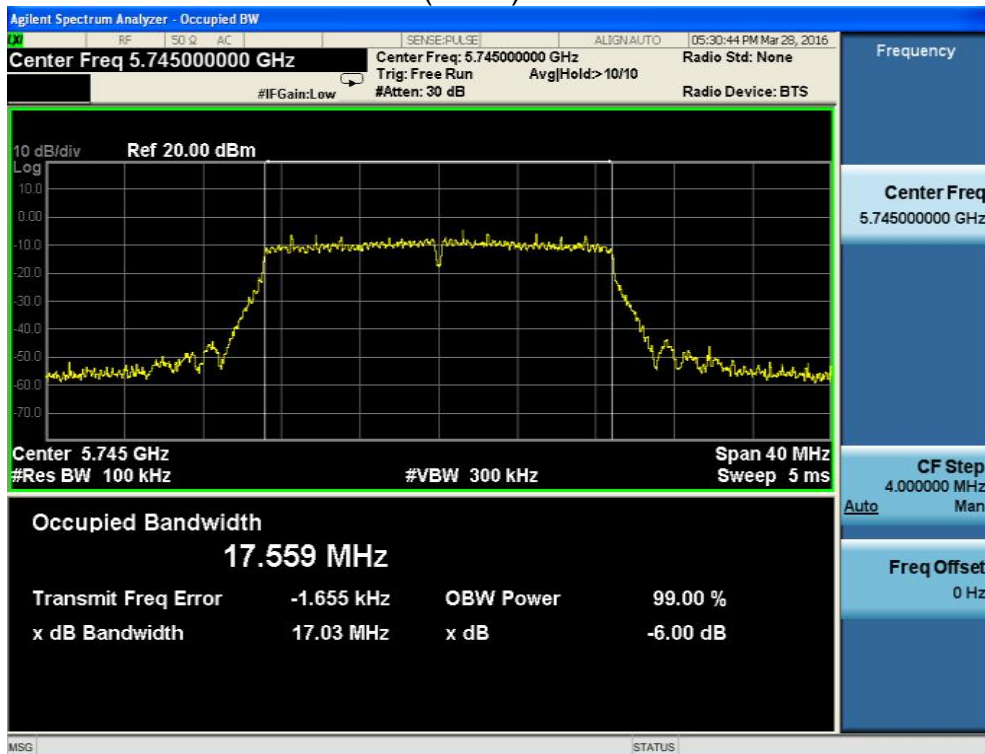



802.11n(HT20) 5785MHz

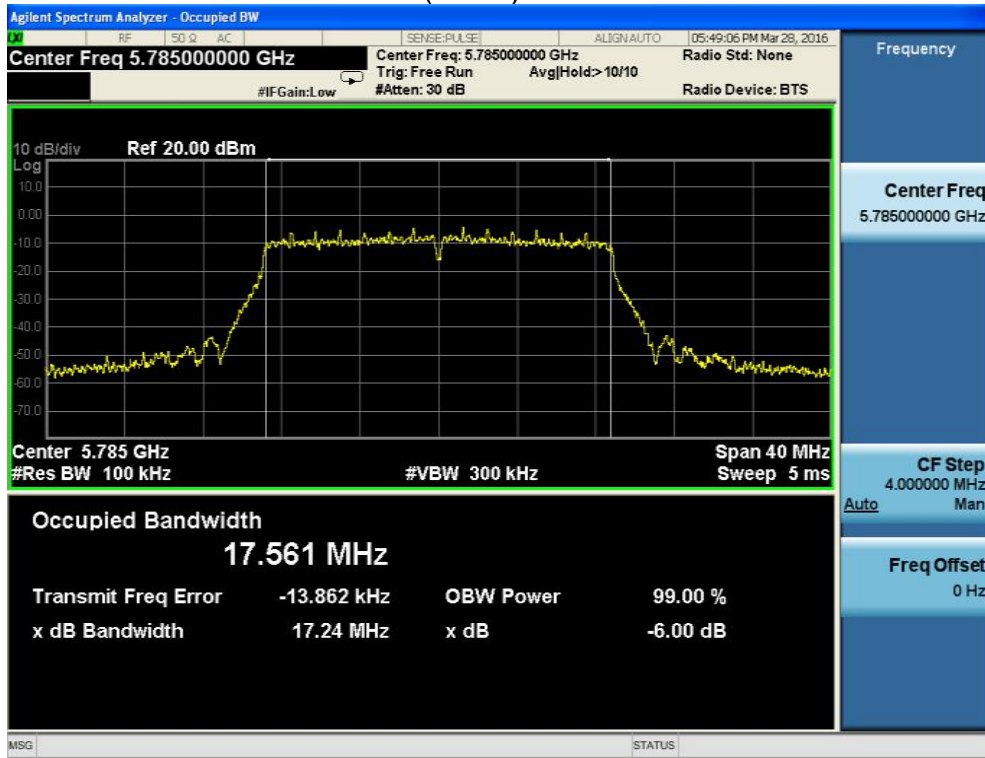

802.11n(HT20) 5825MHz





802.11n(HT40) 5755MHz

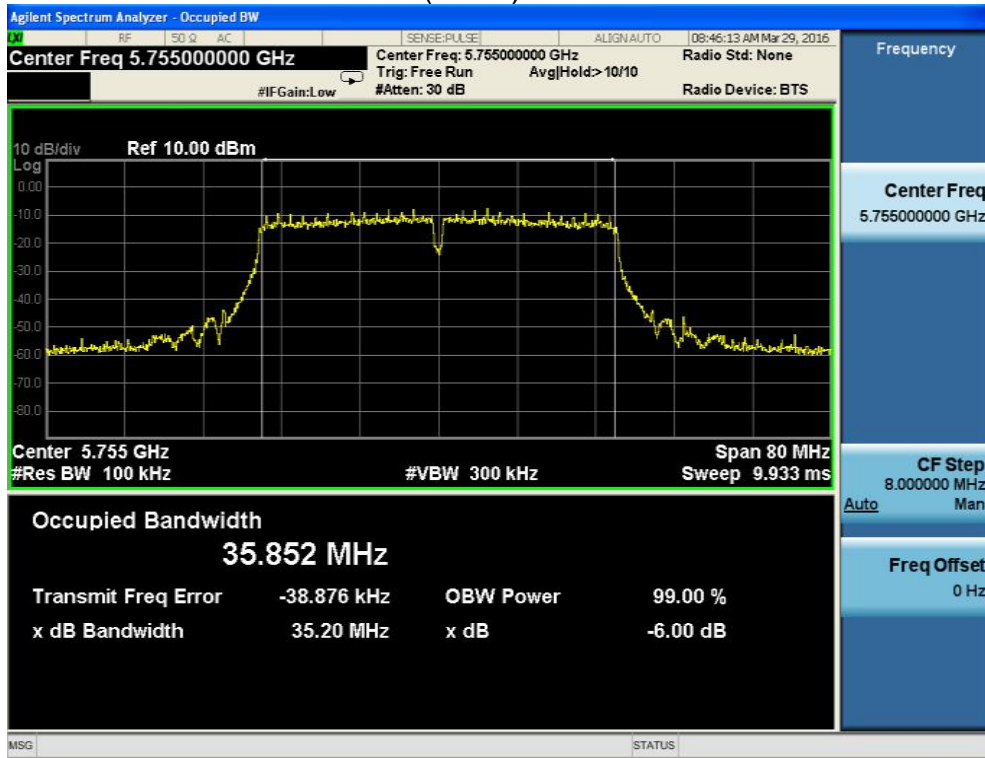

802.11n(HT40) 5795MHz

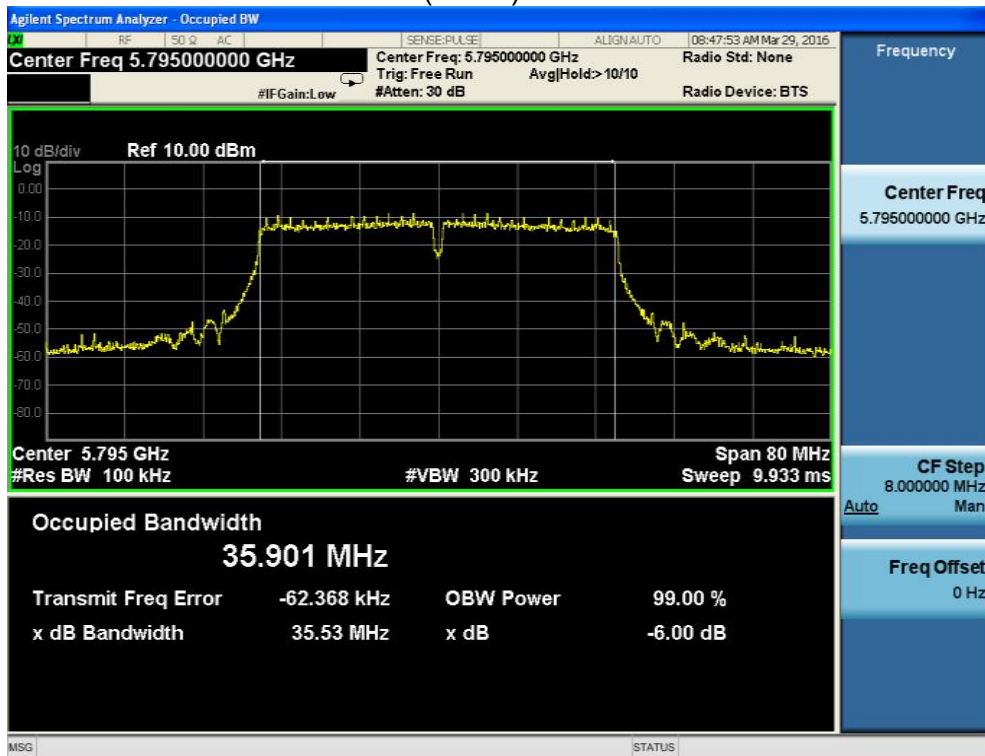



7. OUTPUT POWER TEST

7.1. Limits

For mobile and portable client devices in the 5.15-5.25 GHz band, the maximum conducted output power over the frequency band of operation shall not exceed 250 mW provided the maximum antenna gain does not exceed 6 dBi.

For the band 5.725-5.85 GHz, the maximum conducted output power over the frequency band of operation shall not exceed 1 W.

7.2. Test setup

1. The maximum average conducted output power can be measured using Method PM-G (Measurement using a gated RF average power meter):
2. Measurements may be performed using a wideband gated RF power meter provided that the gate parameters are adjusted such that the power is measured only when the EUT is transmitting at its maximum power control level. Since the measurement is made only during the ON time of the transmitter, no duty cycle correction factor is required.
 - a. The Transmitter output (antenna port) was connected to the power meter.
 - b. Turn on the EUT and power meter and then record the power value.
 - c. Repeat above procedures on all channels needed to be tested.



7.3. Test result

	Frequency (MHz)	Average Output Power(dBm)		Total Power (mW)	Total Power (dBm)	FCC Limit (dBm)	Result
		Ant.1	Ant.2				
802.11a	5180	-6.02	-6.22	0.06	-12.22	23.98	Pass
	5220	-6.35	-6.20	0.06	-12.55	23.98	Pass
	5240	-6.32	-6.30	0.06	-12.62	23.98	Pass
	5745	-6.12	-6.23	0.06	-12.35	30.0	Pass
	5785	-6.10	-6.35	0.06	-12.45	30.0	Pass
	5825	-6.20	-6.38	0.06	-12.58	30.0	Pass
802.11n (HT20)	5180	-6.50	-6.51	0.05	-13.01	23.98	Pass
	5220	-6.50	-6.72	0.05	-13.22	23.98	Pass
	5240	-6.70	-6.65	0.05	-13.35	23.98	Pass
	5745	-6.72	-6.80	0.04	-13.52	30.0	Pass
	5785	-6.80	-6.75	0.04	-13.55	30.0	Pass
	5825	-6.75	-6.87	0.04	-13.62	30.0	Pass
802.11n (HT40)	5190	-7.10	-7.00	0.04	-14.10	23.98	Pass
	5230	-6.95	-7.05	0.04	-14.00	23.98	Pass
	5755	-6.95	-7.10	0.04	-14.05	30.0	Pass
	5795	-6.85	-7.13	0.04	-13.98	30.0	Pass



8. PEAK POWER SPECTRAL DENSITY TEST

8.1. Limits

In addition, the maximum power spectral density shall not exceed 11 dBm in any 1 megahertz band.

In addition, the maximum power spectral density shall not exceed 30 dBm in any 500 kHz band.

8.2. Test setup

1. Place the EUT on the table and set it in transmitting mode.
2. The testing follows FCC KDB 789033 D02.
3. Remove the antenna from the EUT and then connect a low loss RF cable from the antenna port to

Spectrum.

4. For U-NII1, U-NII-2A, U-NII-2C Band:

Set RBW=1MHz, VBW=3*RBW, where span is enough to capture the entire bandwidth, Sweep time = Auto (601 pts), detector = sample, traces 100 sweeps of video averaging. (SA-2 with the omission of procedure x, the integration with 26dB EBW bandwidth)

For U-NII-3 Band:

Set RBW=500 kHz, VBW=3*RBW, where span is enough to capture the entire bandwidth, Sweep time = Auto (601 pts), detector = sample, traces 100 sweeps of video averaging. (SA-2 with the omission of procedure x, the integration with 26dB EBW bandwidth)

5. Use the cursor on spectrum to peak search the highest level of trace
6. Record the max. reading and add $10 \log(1/\text{duty cycle})$.

we test all antennas, the antenna 1 was worst mode and the data recording in the report.



8.3. Test data

Test data as below

	Frequency (MHz)	Reading Level (dBm)	Duty factor (dB)	Duty factor 10 log (1MHz/RBW)	PPSD (dBm)	FCC Limit (dBm)	Result
802.11a	5180	-6.67	0.21	0.0	-6.46	11.00	Pass
	5220	-7.57	0.21	0.0	-7.36	11.00	Pass
	5240	-7.78	0.21	0.0	-7.57	11.00	Pass
	5745	-5.69	0.21	0.0	-5.48	30.00	Pass
	5785	-7.52	0.21	0.0	-7.31	30.00	Pass
	5825	-7.80	0.21	0.0	-7.59	30.00	Pass
802.11n (HT20)	5180	-8.76	0.44	0.0	-8.32	11.00	Pass
	5220	-7.67	0.44	0.0	-7.23	11.00	Pass
	5240	-7.28	0.44	0.0	-6.84	11.00	Pass
	5745	-7.69	0.44	0.0	-7.25	30.00	Pass
	5785	-6.66	0.44	0.0	-6.22	30.00	Pass
	5825	-7.09	0.44	0.0	-6.65	30.00	Pass
802.11n (HT40)	5190	-8.78	0.77	0.0	-8.01	11.00	Pass
	5230	-9.60	0.77	0.0	-8.83	11.00	Pass
	5755	-10.70	0.77	0.0	-9.93	30.00	Pass
	5795	-9.02	0.77	0.0	-8.25	30.00	Pass

Note: where x is the duty cycle.



802.11a 5180MHz

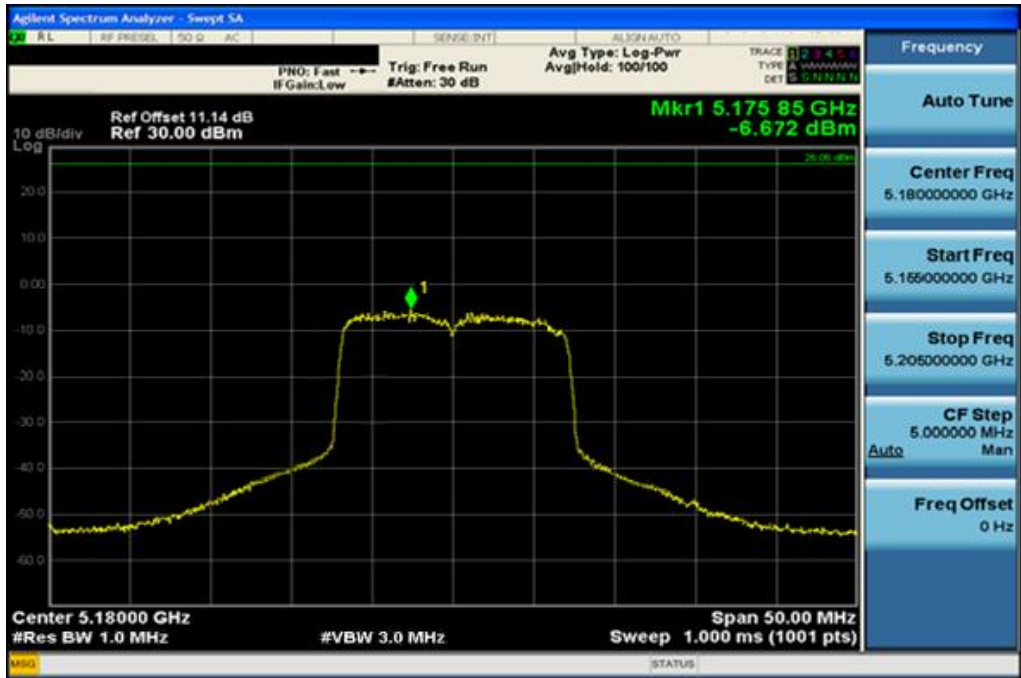

802.11a 5200MHz

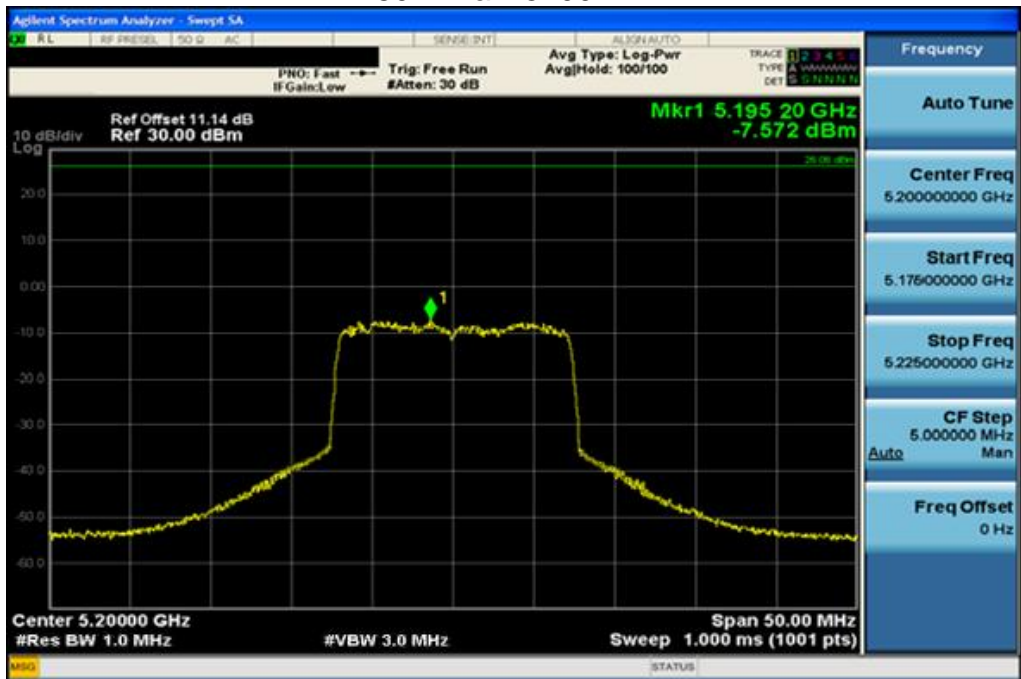



802.11a 5240MHz

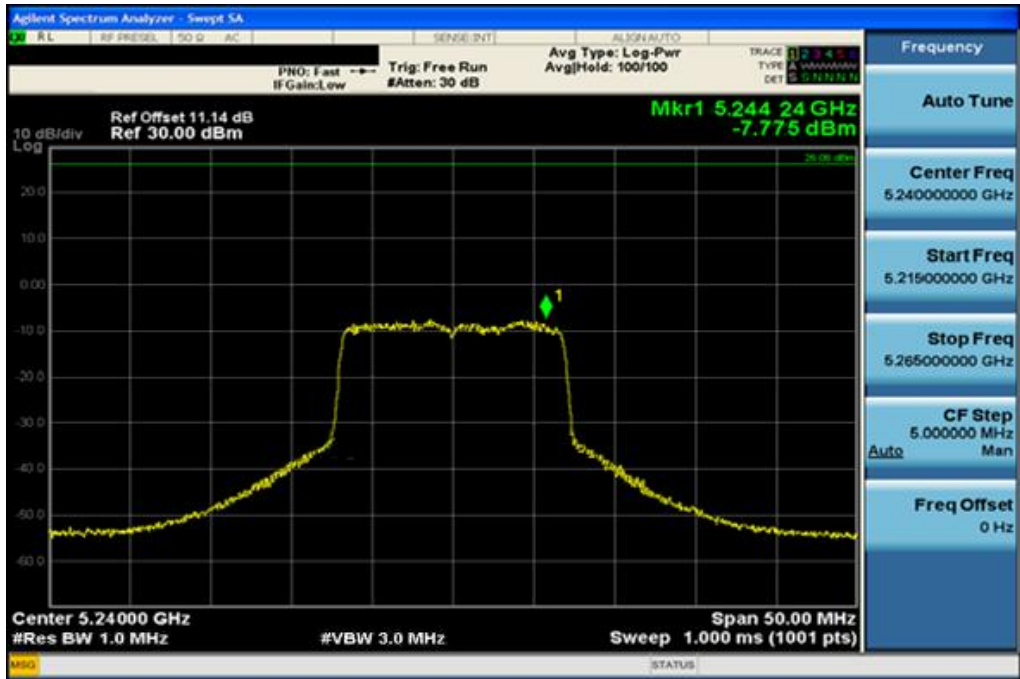

802.11a 5745MHz

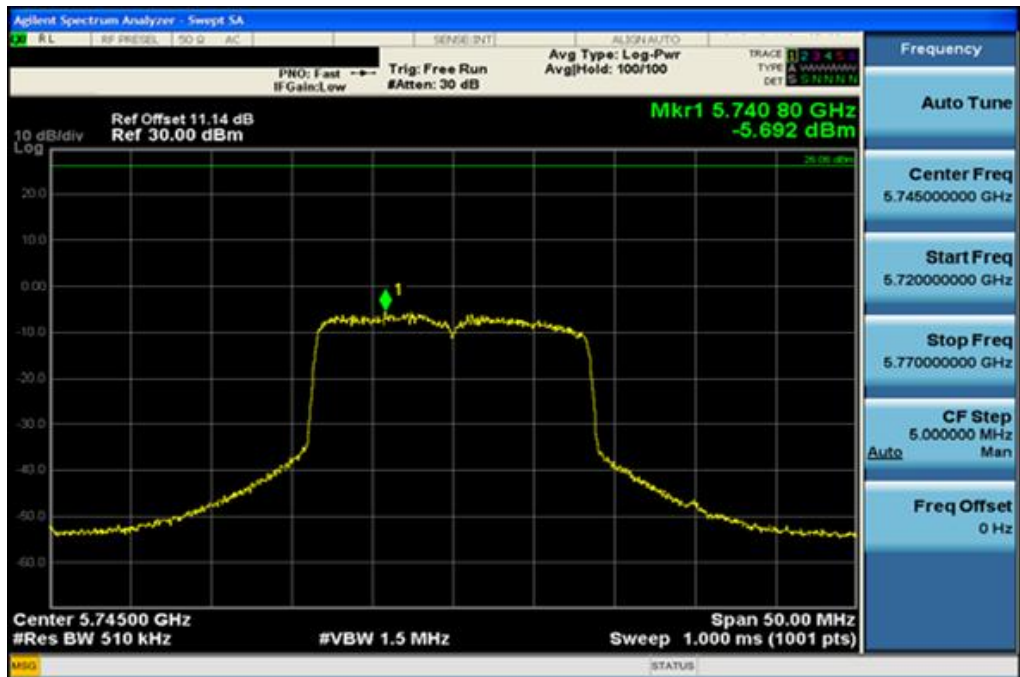



802.11a 5785MHz

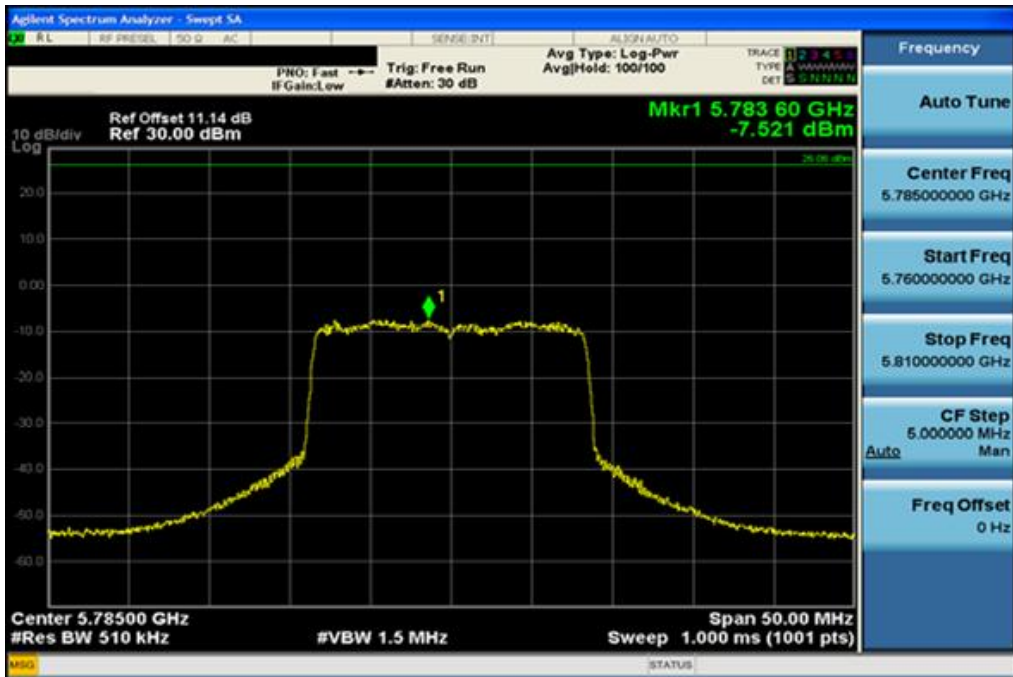

802.11a 5825MHz

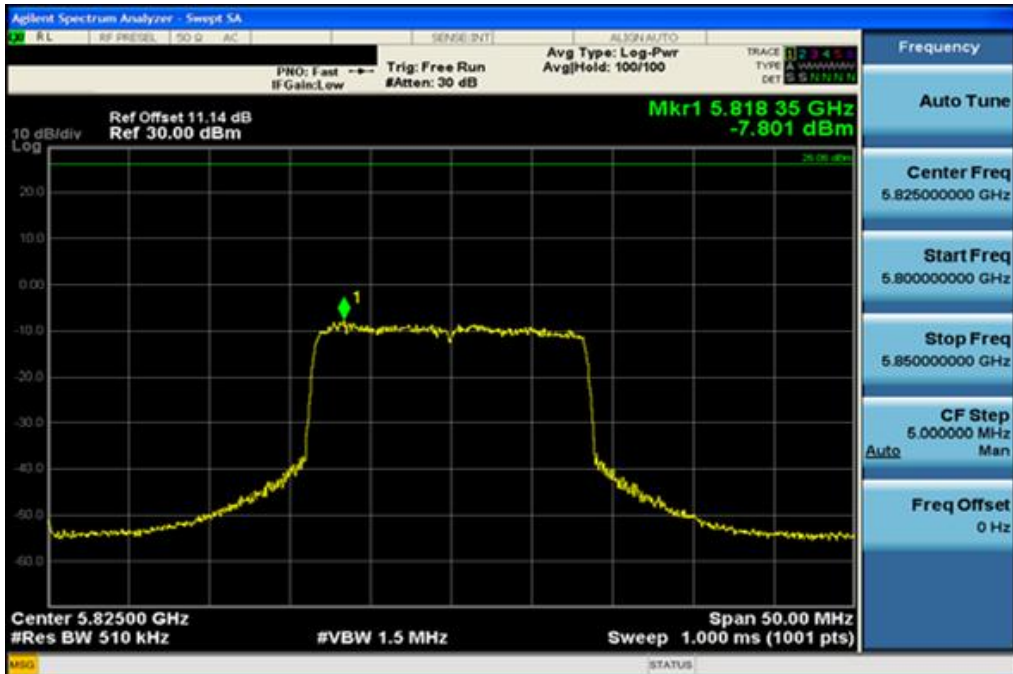



802.11n(HT20) 5180MHz

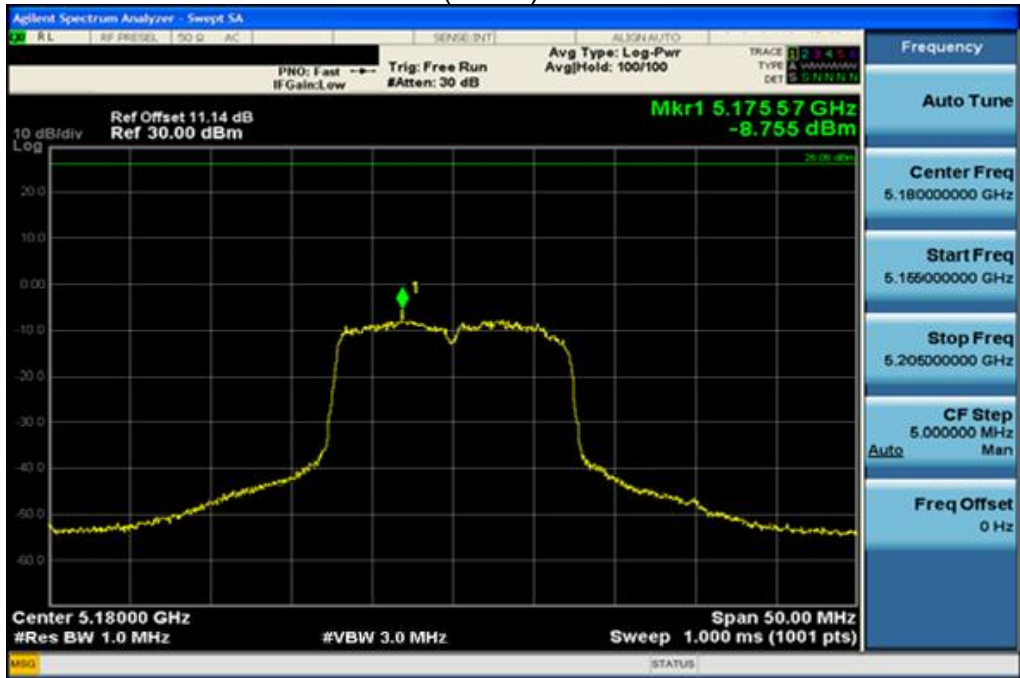

802.11n(HT20) 5200MHz

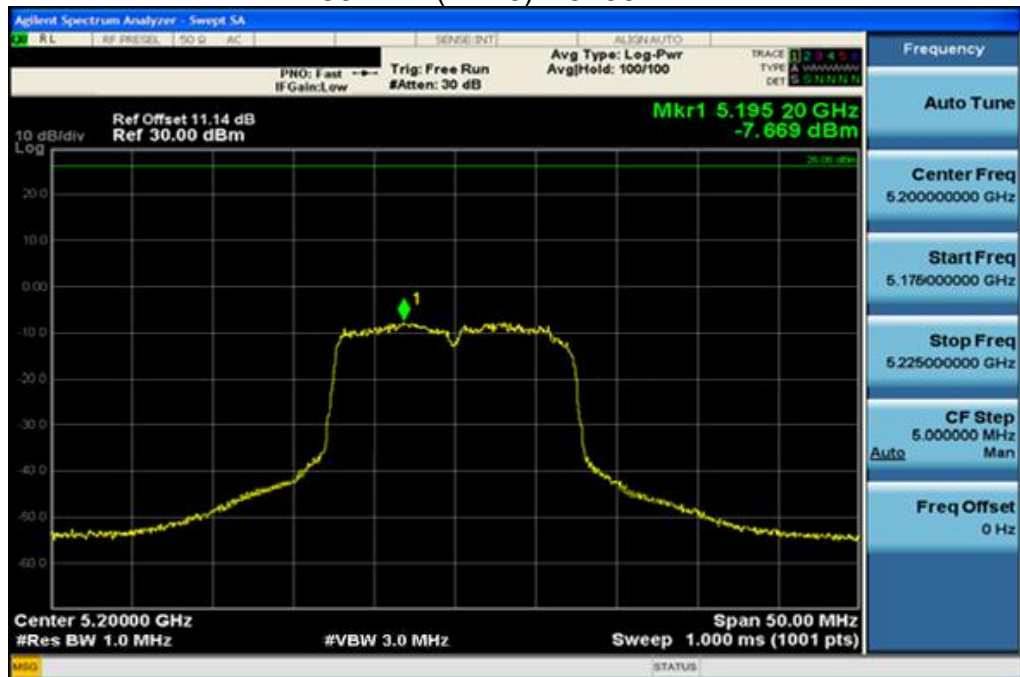



802.11n(HT20) 5240MHz

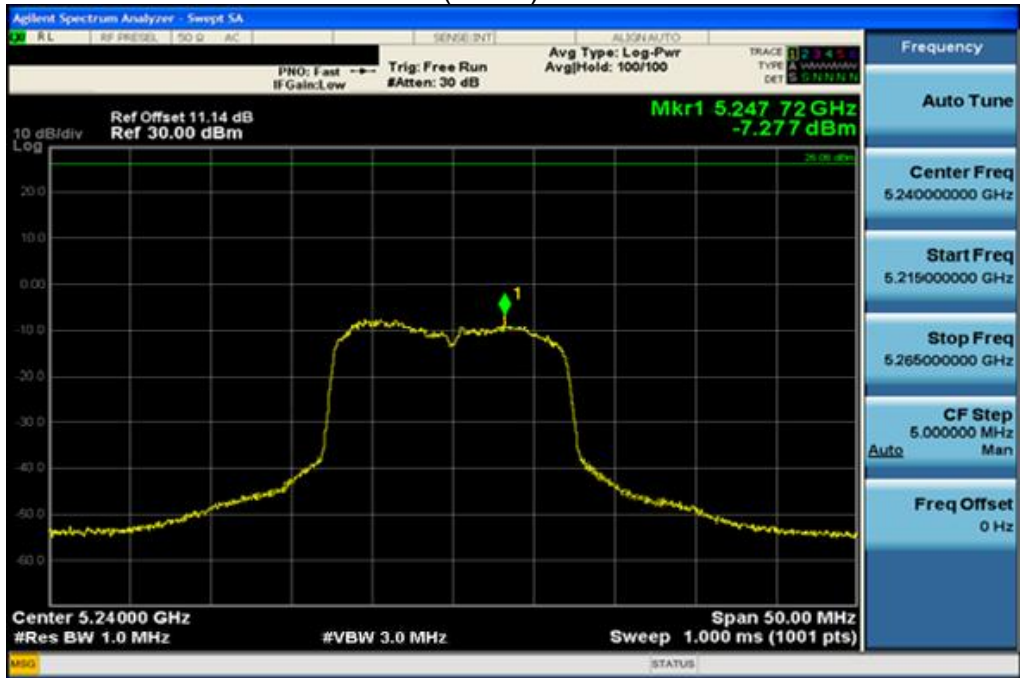

802.11n(HT20) 5745MHz

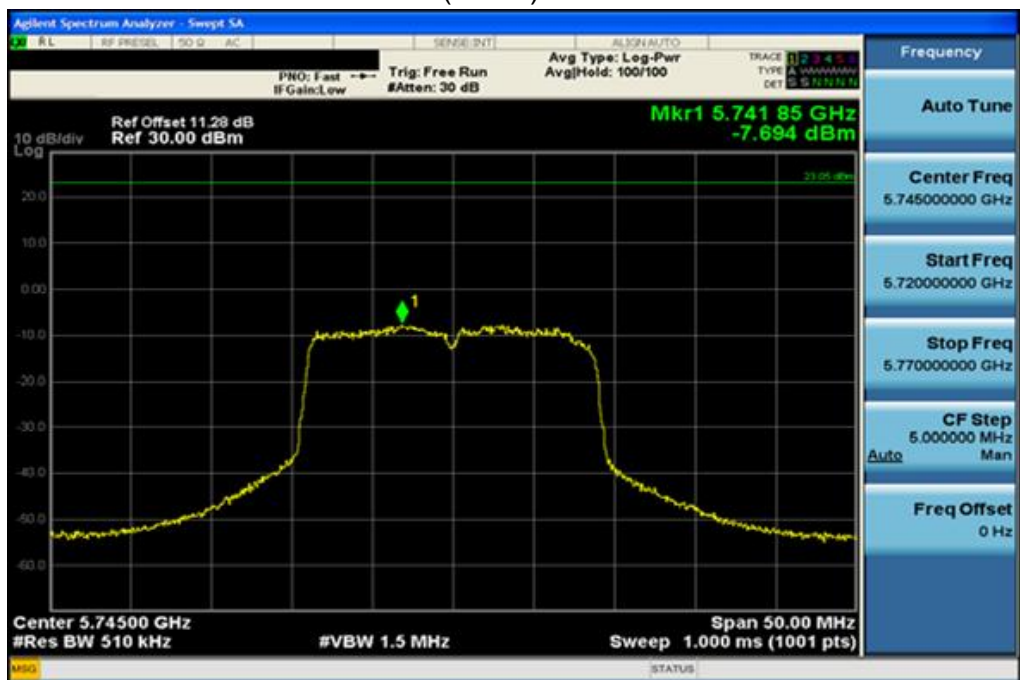



802.11n(HT20) 5785MHz

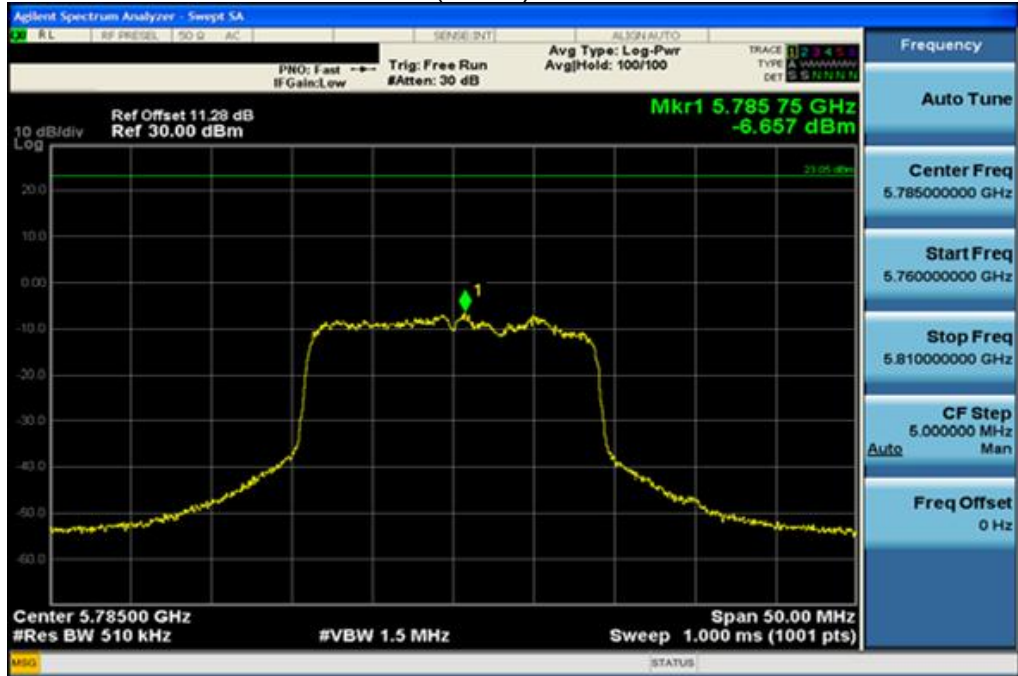

802.11n(HT20) 5825MHz

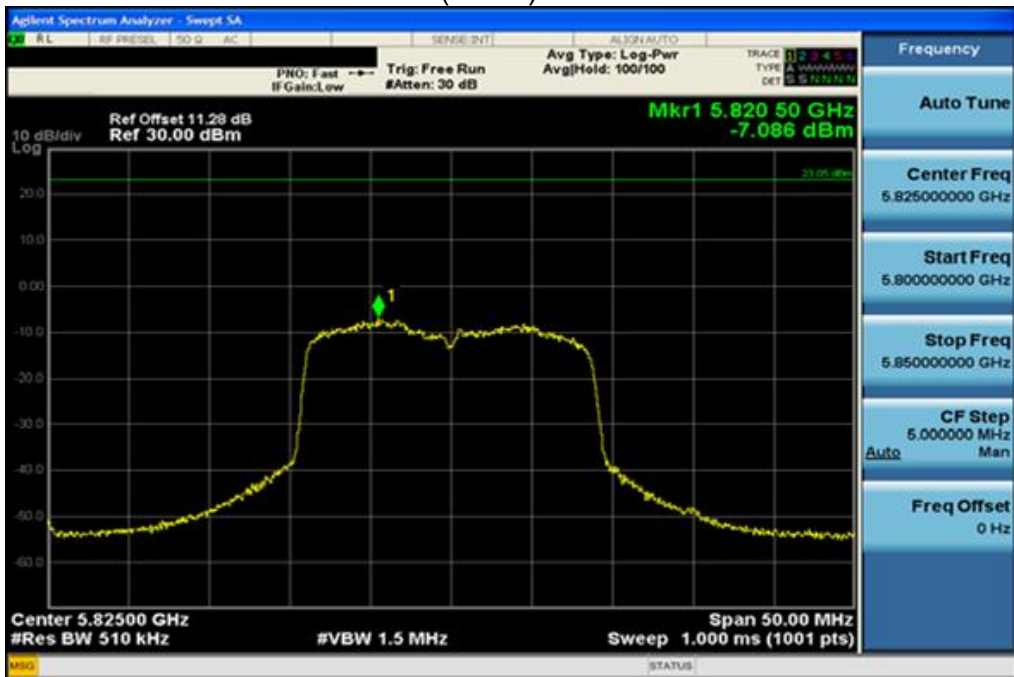



802.11n(HT40) 5190MHz

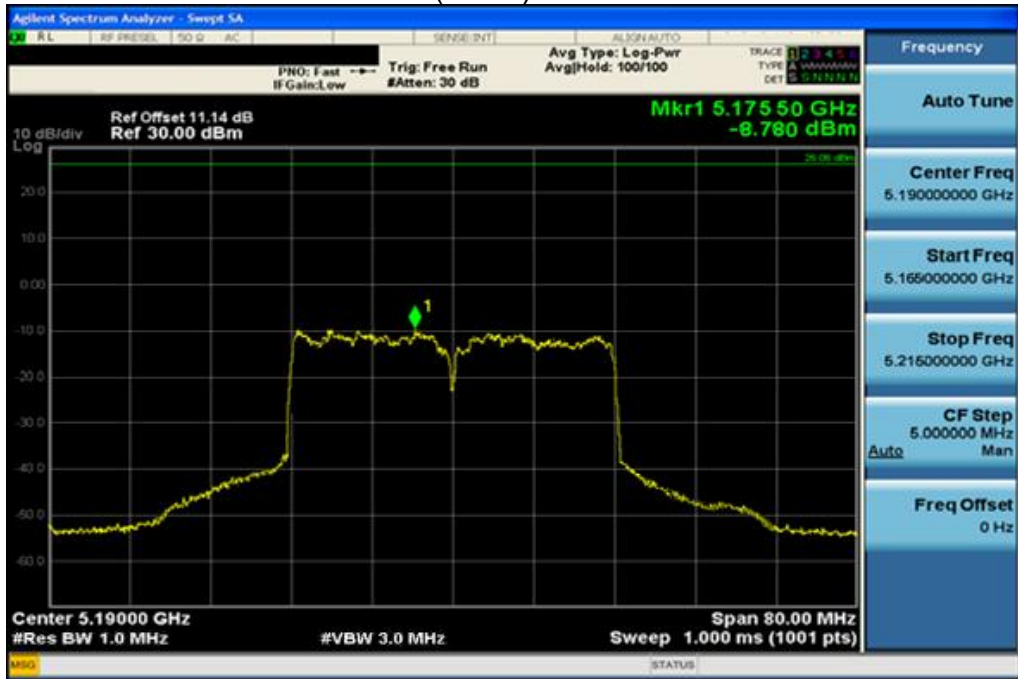

802.11n(HT40) 5230MHz





9. DUTY CYCLE TEST SIGNAL

Pre-analysis Check: While conducting average power measurement, duty cycle of each mode shall be checked to ensure its duty cycle in order to compensate for the loss due to insufficient ratio of duty cycle.

All duty cycle is pre-scanned, and result as obtained below shows only the most representative ones where duty cycle is conducted as the given transmission with given virtual operation that expresses the percentage.

Formula:

$$\text{Duty Cycle} = T_{\text{on}} / (T_{\text{on}} + T_{\text{off}})$$

Measurement Procedure:

1. Set span = Zero
2. RBW = 8MHz
3. VBW = 8MHz,
4. Detector = Peak

Duty Cycle:

Operation Mode	Duty Cycle	Duty Fator (dB) $10 * \log (1/ \text{Duty cycle})$
802.11a	95.35%	0.21
802.11n(HT20)	90.78%	0.42
802.11n(HT40)	83.76%	0.77



802.11a

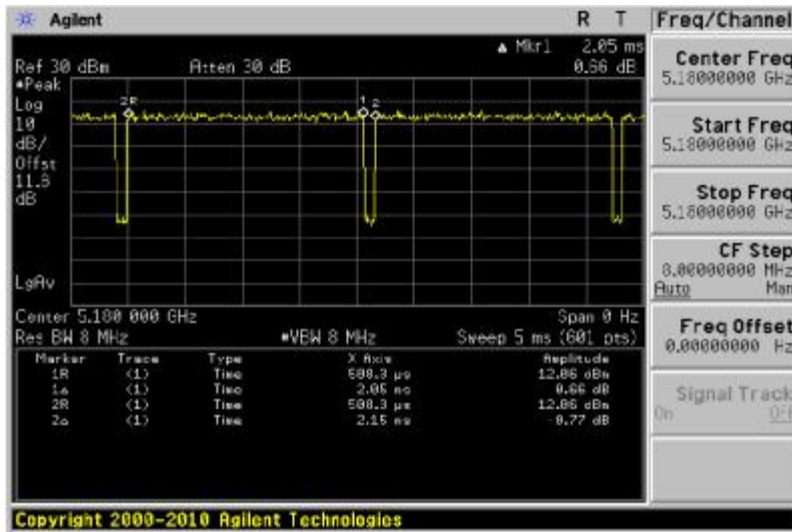

802.11n(HT20)

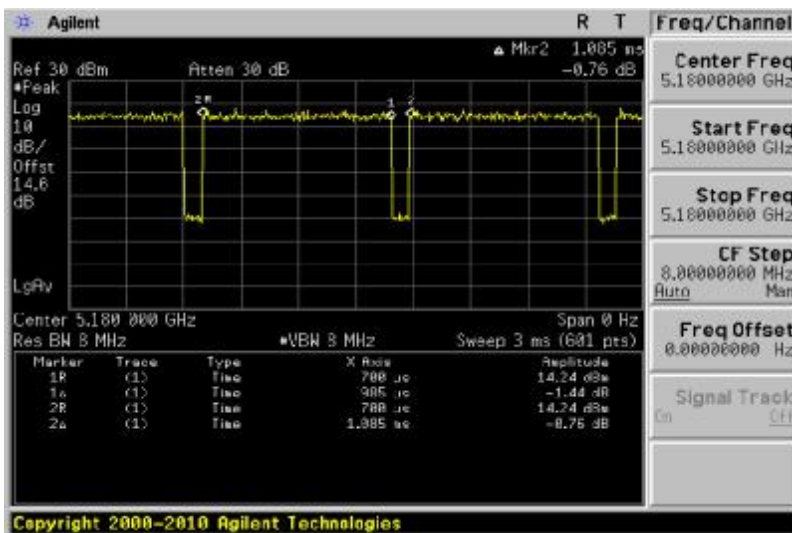

802.11n(HT40)

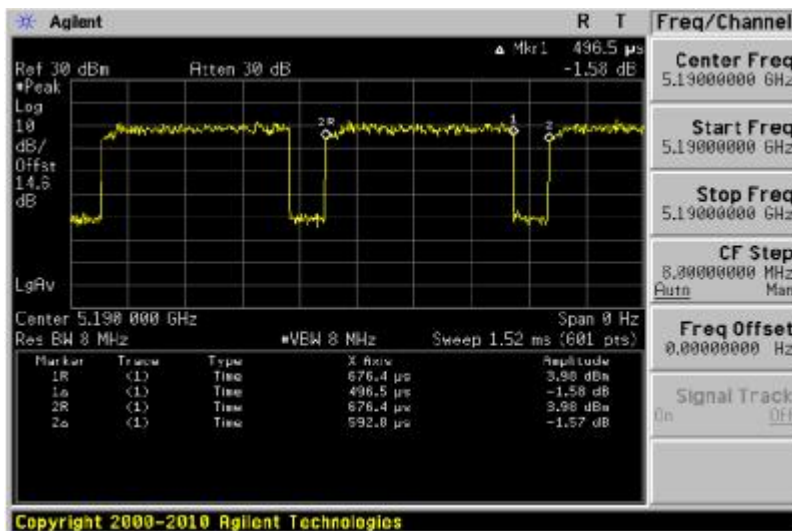



10. FREQUENCY STABILITY

10.1. Limits

Manufacturers of U-NII devices are responsible for ensuring frequency stability such that an emission is maintained within the band of operation under all conditions of normal operation as specified in the user's manual.

10.2. Test setup

1. The EUT was placed inside temperature chamber and powered and powered by nominal DC voltage.
2. Set EUT as normal operation.
3. Turn the EUT on and couple its output to spectrum.
4. Turn the EUT off and set the chamber to the highest temperature specified.
5. Allow sufficient time (approximately 30 min) for the temperature of the chamber to stabilize, turn the EUT and measure the operating frequency.
6. Repeat step with the temperature chamber set to the lowest temperature.

we test all antennas, the antenna 1 was worst mode and the data recording in the report.



10.3. Test data

Test data as below

Ant 1

	Test Voltage	Test Temp.	Measured Frequency (MHz)	Spectrum Frequency (MHz)	Δ Frequency (MHz)	
802.11a	4.255V	-20°C	5180.000	5180.0427	-0.0427	
			5220.000	5220.0346	-0.0346	
			5240.000	5240.0247	-0.0247	
			5745.000	5745.0341	-0.0341	
			5785.000	5785.0362	-0.0362	
			5825.000	5825.0342	-0.0342	
	3.145V		5180.000	5180.0247	-0.0247	
			5220.000	5220.0318	-0.0318	
			5240.000	5240.0276	-0.0276	
			5745.000	5745.0294	-0.0294	
			5785.000	5785.0347	-0.0347	
			5825.000	5825.0418	-0.0418	
	3.70V	25°C	5180.000	5180.0517	-0.0517	
			5220.000	5220.0249	-0.0249	
			5240.000	5240.0361	-0.0361	
			5745.000	5745.0347	-0.0347	
			5785.000	5785.0428	-0.0428	
			5825.000	5825.0294	-0.0294	
	4.255V		50°C	5180.000	5180.0347	-0.0347
				5220.000	5220.0264	-0.0264
				5240.000	5240.0318	-0.0318
				5745.000	5745.0614	-0.0614
				5785.000	5785.0418	-0.0418
				5825.000	5825.0611	-0.0611
3.145V	50°C	5180.000		5180.0336	-0.0336	
		5220.000		5220.0275	-0.0275	
		5240.000		5240.0361	-0.0361	
		5745.000		5745.0484	-0.0484	
		5785.000		5785.0294	-0.0294	
		5825.000		5825.0741	-0.0741	



Ant 2

	Test Voltage	Test Temp.	Measured Frequency (MHz)	Spectrum Frequency (MHz)	Δ Frequency (MHz)	
802.11a	4.255V	-20°C	5180.000	5180.0353	-0.0353	
			5220.000	5220.0346	-0.0346	
			5240.000	5240.0254	-0.0254	
			5745.000	5745.0325	-0.0325	
			5785.000	5785.0333	-0.0333	
			5825.000	5825.0342	-0.0342	
	3.145V		5180.000	5180.0274	-0.0274	
			5220.000	5220.0325	-0.0325	
			5240.000	5240.0254	-0.0254	
			5745.000	5745.0261	-0.0261	
			5785.000	5785.0343	-0.0343	
			5825.000	5825.0428	-0.0428	
	3.70V	25°C	5180.000	5180.0553	-0.0553	
			5220.000	5220.0242	-0.0242	
			5240.000	5240.0351	-0.0351	
			5745.000	5745.0327	-0.0327	
			5785.000	5785.0443	-0.0443	
			5825.000	5825.0259	-0.0259	
	4.255V		50°C	5180.000	5180.0357	-0.0357
				5220.000	5220.0261	-0.0261
				5240.000	5240.0326	-0.0326
				5745.000	5745.0642	-0.0642
				5785.000	5785.0461	-0.0461
				5825.000	5825.0642	-0.0642
3.145V	50°C	5180.000		5180.0326	-0.0326	
		5220.000		5220.0246	-0.0246	
		5240.000		5240.0374	-0.0374	
		5745.000		5745.0451	-0.0451	
		5785.000		5785.0263	-0.0263	
		5825.000		5825.0741	-0.0741	



Ant 1

	Test Voltage	Test Temp.	Measured Frequency (MHz)	Spectrum Frequency (MHz)	Δ Frequency (MHz)
802.11n20	4.255V	-20°C	5180.000	5180.0417	-0.0417
			5220.000	5220.0364	-0.0364
			5240.000	5240.0269	-0.0269
			5745.000	5745.0674	-0.0674
			5785.000	5785.0249	-0.0249
			5825.000	5825.0337	-0.0337
	3.145V	-20°C	5180.000	5180.0289	-0.0289
			5220.000	5220.0519	-0.0519
			5240.000	5240.0347	-0.0347
			5745.000	5745.0427	-0.0427
			5785.000	5785.0428	-0.0428
			5825.000	5825.0218	-0.0218
	3.70V	25°C	5180.000	5180.0247	-0.0247
			5220.000	5220.0351	-0.0351
			5240.000	5240.0428	-0.0428
			5745.000	5745.0617	-0.0617
			5785.000	5785.0347	-0.0347
			5825.000	5825.0518	-0.0518
	4.255V	50°C	5180.000	5180.0267	-0.0267
			5220.000	5220.0314	-0.0314
			5240.000	5240.0516	-0.0516
			5745.000	5745.0324	-0.0324
			5785.000	5785.0614	-0.0614
			5825.000	5825.0287	-0.0287
3.145V	50°C	5180.000	5180.0327	-0.0327	
		5220.000	5220.0287	-0.0287	
		5240.000	5240.0611	-0.0611	
		5745.000	5745.0387	-0.0387	
		5785.000	5785.0269	-0.0269	
		5825.000	5825.0334	-0.0334	



Ant 2

	Test Voltage	Test Temp.	Measured Frequency (MHz)	Spectrum Frequency (MHz)	Δ Frequency (MHz)
802.11n20	4.255V	-20°C	5180.000	5180.0421	-0.0421
			5220.000	5220.0374	-0.0374
			5240.000	5240.0216	-0.0216
			5745.000	5745.0652	-0.0652
			5785.000	5785.0236	-0.0236
			5825.000	5825.0344	-0.0344
	3.145V	-20°C	5180.000	5180.0274	-0.0274
			5220.000	5220.0526	-0.0526
			5240.000	5240.0341	-0.0341
			5745.000	5745.0434	-0.0434
			5785.000	5785.0426	-0.0426
			5825.000	5825.0227	-0.0227
	3.70V	25°C	5180.000	5180.0241	-0.0241
			5220.000	5220.0361	-0.0361
			5240.000	5240.0474	-0.0474
			5745.000	5745.0667	-0.0667
			5785.000	5785.0324	-0.0324
			5825.000	5825.0526	-0.0526
	4.255V	50°C	5180.000	5180.0243	-0.0243
			5220.000	5220.0361	-0.0361
			5240.000	5240.0558	-0.0558
			5745.000	5745.0352	-0.0352
			5785.000	5785.0674	-0.0674
			5825.000	5825.0225	-0.0225
3.145V	50°C	5180.000	5180.0351	-0.0351	
		5220.000	5220.0274	-0.0274	
		5240.000	5240.0662	-0.0662	
		5745.000	5745.0358	-0.0358	
		5785.000	5785.0252	-0.0252	
		5825.000	5825.0361	-0.0361	



Ant 1

	Test Voltage	Test Temp.	Measured Frequency (MHz)	Spectrum Frequency (MHz)	Δ Frequency (MHz)
802.11n40	4.255V	-20°C	5190.000	5190.0267	-0.0267
			5230.000	5230.0364	-0.0364
			5755.000	5755.0517	-0.0517
			5795.000	5795.0641	-0.0641
	3.145V		5190.000	5190.0297	-0.0297
			5230.000	5230.0384	-0.0384
			5755.000	5755.0275	-0.0275
			5795.000	5795.0466	-0.0466
	3.70V	25°C	5190.000	5190.0258	-0.0258
			5230.000	5230.0618	-0.0618
			5755.000	5755.0268	-0.0268
			5795.000	5795.0517	-0.0517
	4.255V	50°C	5190.000	5190.0617	-0.0617
			5230.000	5230.0546	-0.0546
			5755.000	5755.0417	-0.0417
			5795.000	5795.0349	-0.0349
3.145V	50°C	5190.000	5190.0521	-0.0521	
		5230.000	5230.0328	-0.0328	
		5755.000	5755.0337	-0.0337	
		5795.000	5795.0419	-0.0419	



Ant 2

	Test Voltage	Test Temp.	Measured Frequency (MHz)	Spectrum Frequency (MHz)	Δ Frequency (MHz)
802.11n40	4.255V	-20°C	5190.000	5190.0228	-0.0228
			5230.000	5230.0316	-0.0316
			5755.000	5755.0557	-0.0557
			5795.000	5795.0626	-0.0626
	3.145V		5190.000	5190.0231	-0.0231
			5230.000	5230.0357	-0.0357
			5755.000	5755.0216	-0.0216
			5795.000	5795.0424	-0.0424
	3.70V	25°C	5190.000	5190.0218	-0.0218
			5230.000	5230.0633	-0.0633
			5755.000	5755.0256	-0.0256
			5795.000	5795.0227	-0.0227
	4.255V	50°C	5190.000	5190.0627	-0.0627
			5230.000	5230.0543	-0.0543
			5755.000	5755.0447	-0.0447
			5795.000	5795.0355	-0.0355
3.145V	50°C	5190.000	5190.0534	-0.0534	
		5230.000	5230.0323	-0.0323	
		5755.000	5755.0374	-0.0374	
		5795.000	5795.0466	-0.0466	



11. TRANSMISSION IN THE ABSENCE OF DATA

11.1. Limits

According to §15.407(c)

The device shall automatically discontinue transmission in case of either absence of information to transmit or operational failure. These provisions are not intended to preclude the transmission of control or signaling information or the use of repetitive codes used by certain digital technologies to complete frame or burst intervals. Applicants shall include in their application for equipment authorization a description of how this requirement is met.

11.2. Test result

No non-compliance noted:

Refer to the theory of operation.

12. PHOTOGRAPHS OF TEST SET-UP

Conducted Emission



Radiated Emission Test

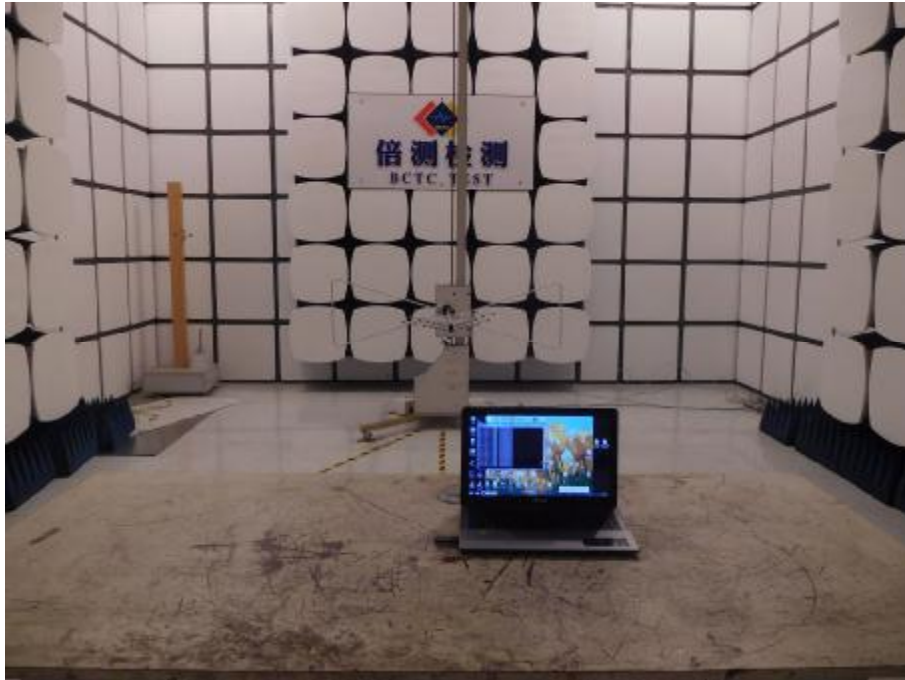

13. PHOTOGRAPHS OF THE EUT

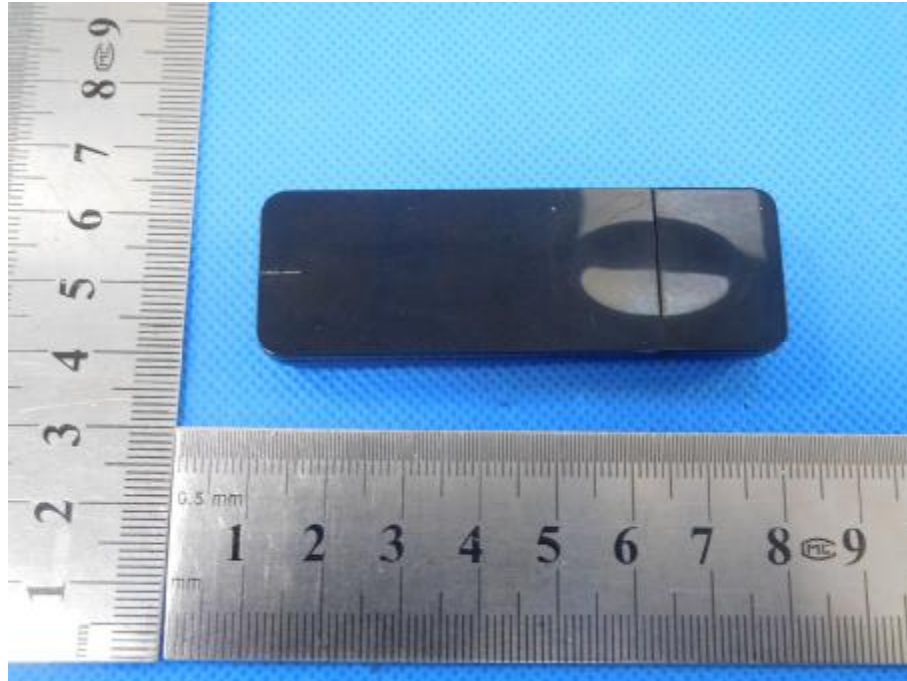

***** END OF REPORT *****