

SAMPLESAMPLESAMPLESAMPLESAMPLE
SAMPLESAMPLESAMPLESAMPLESAMPLE
SAMPLESAMPLESAMPLESAMPLESAMPLE
SAMPLESAMPLESAMPLESAMPLESAMPLE
SAMPLESAMPLESAMPLESAMPLESAMPLE
SAMPLESAMPLESAMPLESAMPLESAMPLE
SAMPLESAMPLESAMPLESAMPLESAMPLE
SAMPLESAMPLESAMPLESAMPLESAMPLE
SAMPLESAMPLESAMPLESAMPLESAMPLE
SAMPLESAMPLESAMPLESAMPLESAMPLE
SAMPLESAMPLESAMPLESAMPLESAMPLE
SAMPLESAMPLESAMPLESAMPLESAMPLE
SAMPLESAMPLESAMPLESAMPLESAMPLE
SAMPLESAMPLESAMPLESAMPLESAMPLE
SAMPLESAMPLESAMPLESAMPLESAMPLE
SAMPLESAMPLESAMPLESAMPLESAMPLE
SAMPLESAMPLESAMPLESAMPLESAMPLE
SAMPLESAMPLESAMPLESAMPLESAMPLE
SAMPLESAMPLESAMPLESAMPLESAMPLE
SAMPLESAMPLESAMPLESAMPLESAMPLE

Bluetooth Mouse

M-XGS30BB

M-XGM30BB

M-XGL30BB

M-XGLL30BB

User Manual

Thank you very much for purchasing this product.

* Each of the “M-XGS30BB/M-XGM30BB/M-XGL30BB/M-XGLL30BB” series is referred to as “this product” in this manual except in some cases.

This manual describes the necessary precautions you should take for safe operation of this product. Observe these precautions carefully to avoid personal injury, damage, fire, and other problems.

■ Meaning of symbols

WARNING

Failure to observe precautions carries the possibility of serious personal injury or death due to fire, electric shock, or other causes.

CAUTION

Failure to observe precautions may result in personal injury due to electric shock or other causes, and may damage other equipment.

 Prohibited action

 Mandatory action

 Situation that needs attention

 Notes and reference information

WARNING

 **If a foreign object (water, metal chips) enters this product, stop using immediately and remove the battery.**

Continuing to use this product as it is may cause a fire or electric shock.

 **If this product behaves abnormally, such as by generating heat or smoke, or giving off strange smells, cease usage immediately and shut down the connected device. After confirming that the product is not generating heat that will cause burns, remove the battery from the product. Afterwards, please contact your dealer.**

Continuing to use the product as it is may cause a fire or electric shock.

 **Please do not drop or hit this product.**

In the event that this product is damaged, cease usage immediately. Turn OFF the power and remove the battery from the mouse. Afterwards, please contact your dealer.

Fires or electric shocks may occur if this product is used when damaged.

 **Do not attempt to disassemble, modify or repair this product.**

Doing so may cause a fire, electric shock, or product damage.

Malfunctions are not covered under warranty.

 **Do not put this product in fire.**

Breakage may cause fire or injury.

 **CAUTION**

 **Do not place this product in any of the following environments:**

- In a car exposed to sunlight or a place exposed to direct sunlight.
 - In a place that becomes hot, such as around a heater.
 - In a moist place or a place where condensation may occur.
 - In an uneven place or a place exposed to vibration.
 - In a place where a magnetic field is generated (such as near a magnet.)
 - In a dusty place.
-

 **This product does not have a waterproof structure. Use or store in a place not exposed to liquids such as water.**

Any liquid such as rain, water spray, juice, coffee, steam, and sweat, may cause this product to breakdown.



- Only use this mouse with PCs, smartphones, tablets, and video game systems.
- Do not use this product with any device that may significantly be affected in the case of this product malfunctioning.
- If this product is used on a transparent surface such as glass or a highly reflective surface such as a mirror, the optical sensor will not function correctly and the mouse cursor movement will become unstable.
- * Although the sensor light is not visible, please note that looking directly into the sensor may hurt your eyes.
- When you no longer need to use this product and the battery, be sure to dispose of them in accordance with the local ordinances and laws of your area.

■ Battery

 **CAUTION**

-  Please use either an AA alkaline battery, an AA manganese battery or an AA nickel-metal hydride rechargeable battery.
-

 **Remove the battery when you are not using this product for long periods of time.**

This may cause leakage or malfunction.

■ **Cleaning the Product**

If the body of this product becomes dirty, wipe with a soft, dry cloth.



Using a volatile liquid such as paint thinner, benzene or alcohol may affect the material quality and/or discolor this product.

Please note the following for disinfection.



Gently soak a cleaning cloth, such as a microfiber cloth, in the disinfectant solution. Make sure there are no loose droplets and gently wipe the product using the cloth.

After wiping, dry thoroughly and wipe off any residual liquid.

* Do not spray any liquid onto the product directly. Doing so can cause electric malfunctions.



IMPORTANT



Do not spray any liquid onto the product directly.

Doing so can cause electric malfunctions.



Do not use organic solvents or ultraviolet lights.

Usage can result in deterioration of the housing components or paints, which can cause damage to the exterior.



We recommend the usage of disposable gloves.



When using any alcohol-based products, please check that it is appropriate for the specific purpose and that it is used properly.



Please note that in the event that damage or abnormal operation to the product is caused by the cleaning process, the customer will be fully responsible for the cost of repair.



We recommend that you disinfect your hands before and after using PCs and peripheral devices that are used by multiple people in order to prevent the spread of infection through the equipment.



Please turn off any connected devices.

* Please turn off connected devices in sleep or hibernation mode.

* Please unplug the AC adapter and power cable from the power outlet.

Cautions for Wireless Equipment

This product is a wireless device that can use the entire 2.4GHz band, and is able to avoid the mobile entity identification device range. The GFSK method is adopted as the radio wave method, and the interference distance is 10m. The 2.4GHz band is also used in medical devices, Bluetooth, and wireless LAN devices of the IEEE 802.11b/11g/11n standards.

- Before using this product, check that there are no other "radio stations"* operating nearby.
- If electromagnetic interference occurs between this product and other "radio stations"*, move this product to another location or stop using this product.

* Other "radio stations" refer to industrial, scientific and medical devices using the 2.4GHz band, the same as this product, other radio stations of this type, licensed radio station premises for a mobile object identification system that is used in factory production lines, certain non-licensed low power radio stations, and amateur radio stations.

WARNING

-  Do not use in equipment which may cause serious effects due to it malfunctioning. There are rare cases in which an external radio wave at the same frequency, or the radio wave emitted from a mobile phone, causes this product to malfunction, slow down, or fail to operate.
 - Do not use this product in places where radio wave usage is prohibited, such as hospitals. Radio waves of this product may affect electronic devices and medical devices (for example pacemakers).
 - Due to the possibility of hindering safe navigation of aircraft, use of wireless mouse in aircraft is prohibited by the Civil Aeronautics Act. Turn off the power of the wireless mouse before boarding and do not use after boarding.
- * ELECOM is not liable for any accidents or any indirect or consequential damage incurred due to the failure of this product.

How to use



Items included in this package



The following are included in this package. Verify the package to ensure all items are accounted for prior to using this product. While every effort has been made to ensure proper packaging, in the event that any shortage or damage is discovered, please contact the retailer where the product was purchased.

- **Mouse x 1**
- **AA alkaline dry cell battery for confirming operability x 1**



It is pre-inserted in the mouse body. Please remove the battery insulating pull tab before use.

Name and function of each part



* This manual uses illustrations of the "M-XGM30BB" series for explanation.

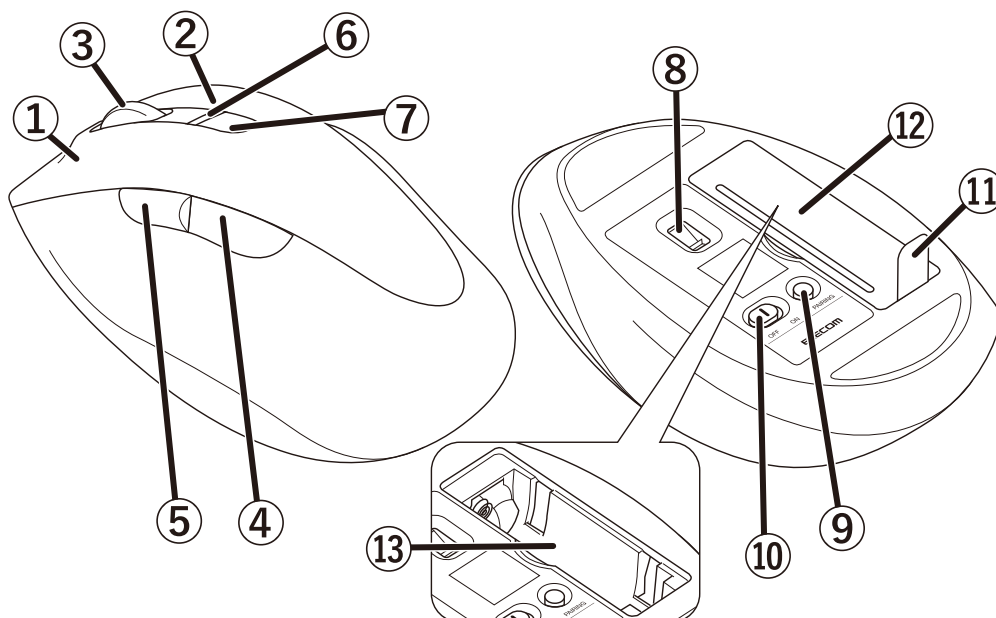

① **Left button**

To left click on your PC.

② **Right button**

To right click on your PC.

③ **Wheel**

Rotate forward and backward or click like a button to operate your PC.

④ **"Back" button**

Perform the "Back" function on the Web browser.

⑤ **"Forward" button**

Perform the "Forward" function on the Web browser.

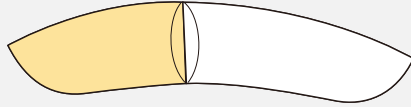

"Forward" button
Continue to next page.

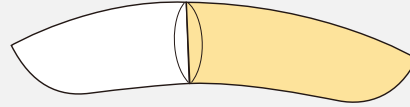

"Back" button
Return to previous page.



You will need to install the "ELECOM Mouse Assistant Mac version" from our website to use the "Back" and "Forward" button on Mac. Please refer to "[Install ELECOM Mouse Assistant](#)".

⑥ LED light

- During pairing standby state, the LED blinks.
- The LED will light up for a period of time when the mouse is switched ON.
- The LED will blink during use when the battery level is low.

The color of the LED changes depending on the device to which it is connected.

PC1 (White)

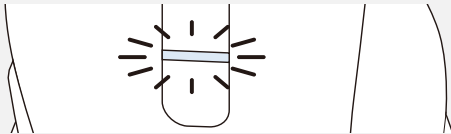

PC2 (Green)

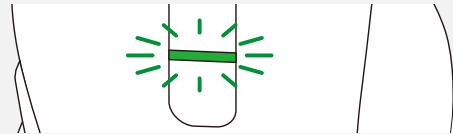

⑦ Device selection button

Use this to switch between devices connected to this product.

Please refer to "[Switch connected device](#)".

⑧ Optical sensor

The LED will light up blue when the battery is inserted into the mouse.

This sensor will detect mouse movements when you move the mouse.

* Please note that looking directly into the sensor light may hurt your eyes.

⑨ Pairing button

Pair the mouse with your device's Bluetooth module or a Bluetooth adapter.

⑩ Power switch

Turn the mouse power on (ON) and off (OFF).

⑪ Battery insulating tab

Remove this tab before using.

⑫ Battery cover

Remove this cover and insert the battery.

⑬ Battery storage compartment

Holds the battery.

Switch connected device

This product can be used to switch between two Bluetooth devices.

Switch between connected Bluetooth devices in the following way.

■ Switch when pairing

1) Click the button to switch between "PC1" and "PC2".

The LED will blink white when the connected device is "PC1" and green when it is "PC2".

PC1 (Blinks in white)

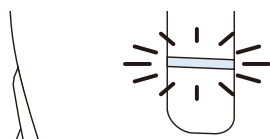

PC2 (Blinks in green)

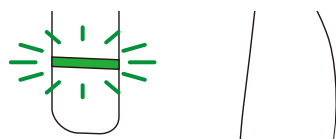

When paired with only one device on either "PC1" or "PC2", the existing connection will be lost when you switch to the unpaired side.

Switching back to the side paired with a connected device will restore the connection.

2) Pair with the selected connected device.



To pair, please refer to "How to use" → "Connecting and setting up the mouse" → (OS specific) → "2. Pair with PC".

■ Switch during use

1) Click the button to switch between "PC1" and "PC2".

2) When the device to be switched to is connected, the LED will light up for about 3 seconds.

The LED will light up white when the connected device is "PC1" and green when "PC2" is connected.

PC1 (White)

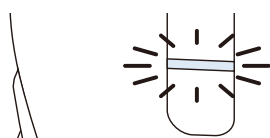

PC2 (Green)

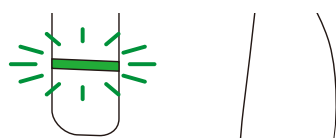



When paired with only one device on either "PC1" or "PC2", the existing connection will be lost when you switch to the unpaired side.

Switching back to the side paired with a connected device will restore the connection.

Connecting and setting up the mouse



Windows®



1. Turn the power ON

1) Remove the battery cover.

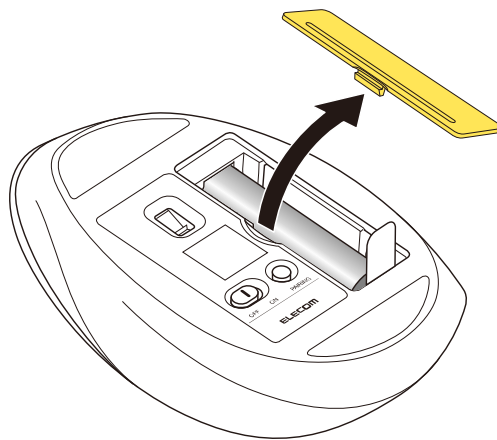

2) Remove the battery insulating tab.

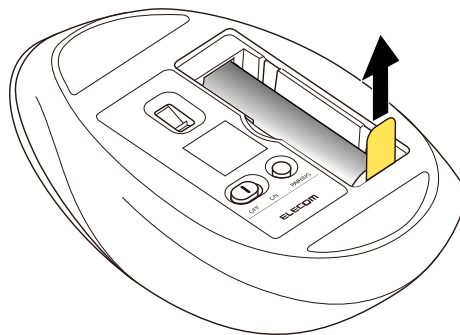

3) Put the battery cover back on.

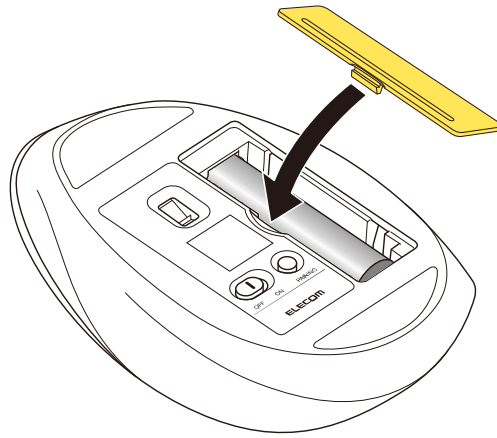

4) Slide the power switch on the underside of the product to the ON position.

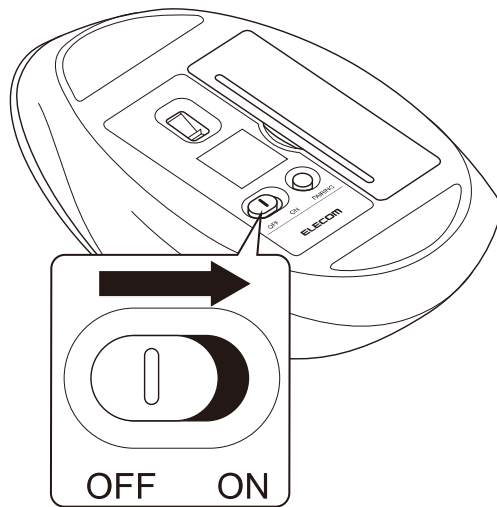

The LED will light up for a period of time.

* When the battery level is running low, the LED will blink for a period of time.



Power-saving mode

When the mouse is left untouched for a fixed period of time while the power is ON, it automatically shifts to power-saving mode.

The mouse returns from power-saving mode when it is moved.

* Mouse operation may be unstable for 2-3 seconds after returning from the power-saving mode.

Replacing the battery...

1) Remove the battery cover.

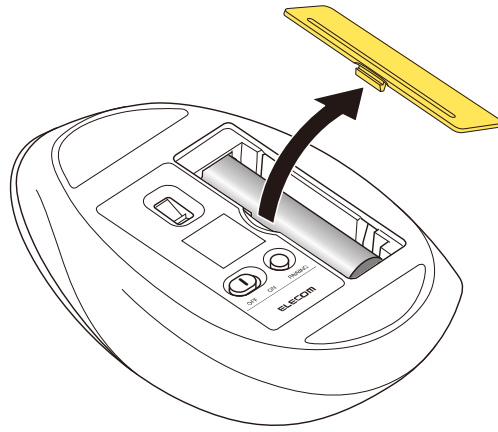

2) Remove the battery.

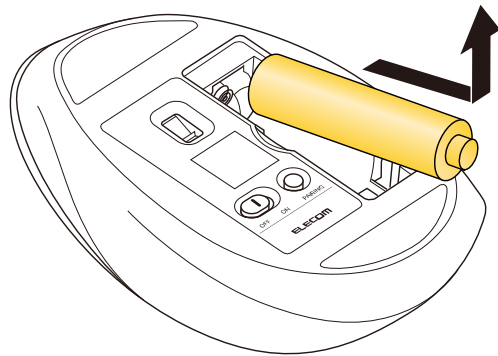

3) Insert the battery according to the instructions on the battery compartment.

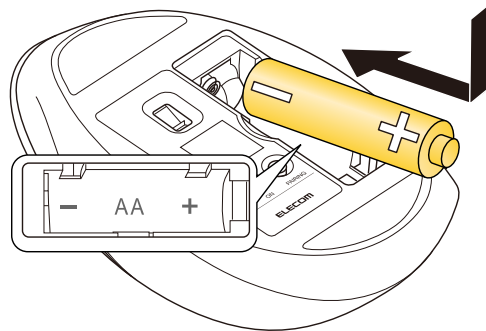

Ensure that the battery is inserted with the positive (+) and negative (-) terminals oriented correctly.

4) Put the battery cover back on.

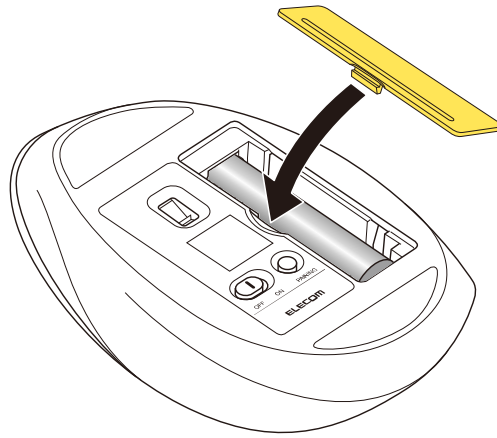

2. Pairing with a PC

- Pairing involves registering Bluetooth devices (in this case, this product and your device) with each other, and authorizing a connection between them.
- This section covers Windows standard Bluetooth functions. Depending on your device or Bluetooth adaptor, unique Bluetooth functions may be used. Please read the respective manuals for each function.
- Please carry out the pairing operation using your current mouse or touchpad on your device.
- The following instructions are for Windows 11 (22H2).

1) Click on “Start” on the bottom of the screen and click on “Settings”.

The “Settings” page will appear.

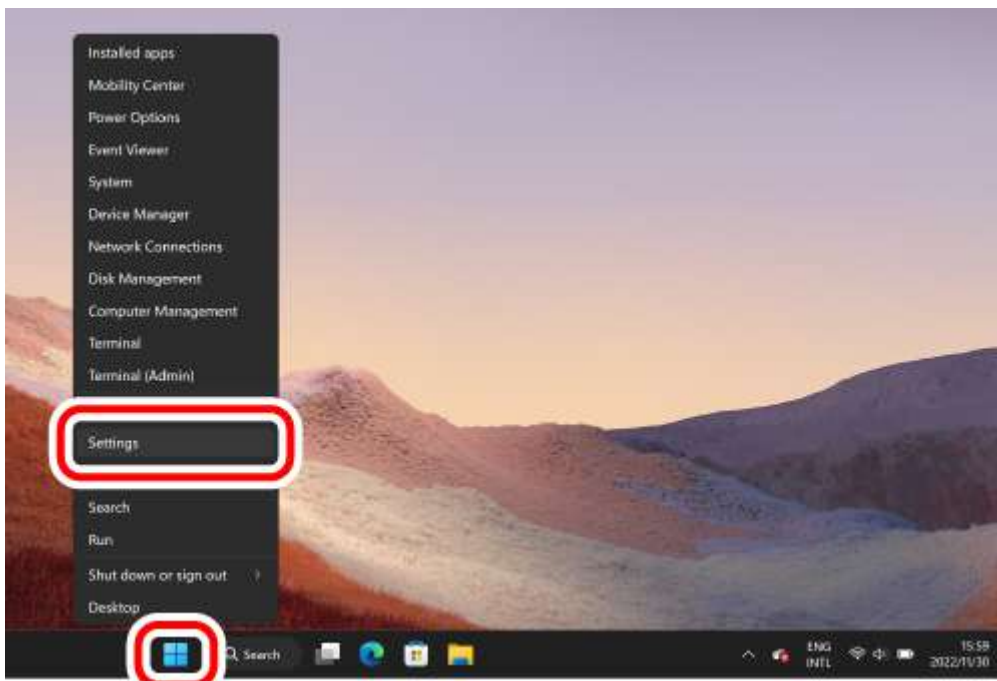

2) Click on “Bluetooth & devices”.

The “Device” page will appear.

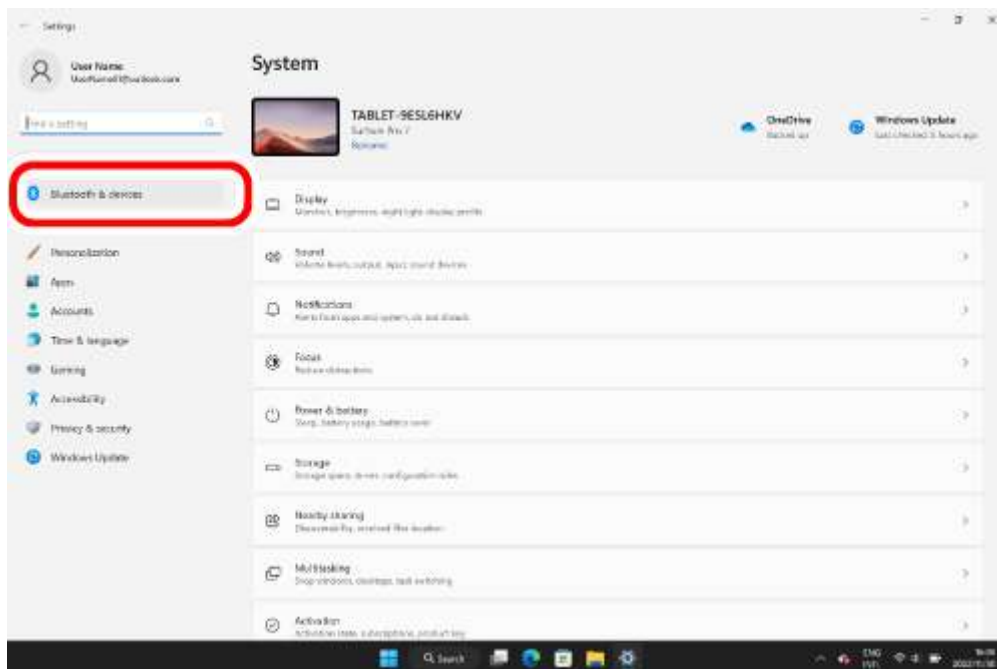

If "Bluetooth" is off, turn it on.

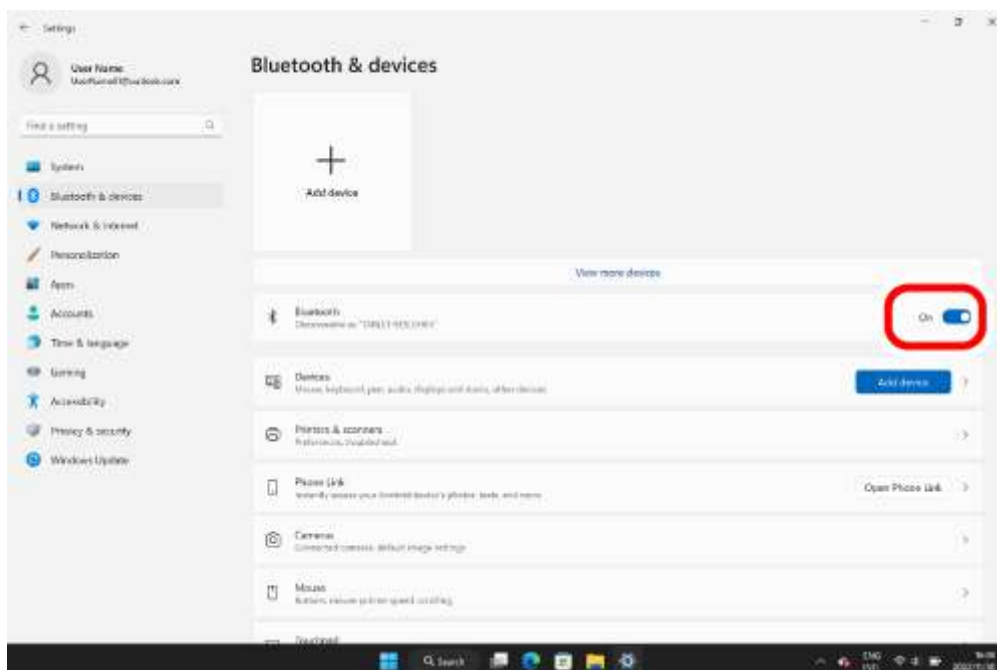

3) Click on "Add device".

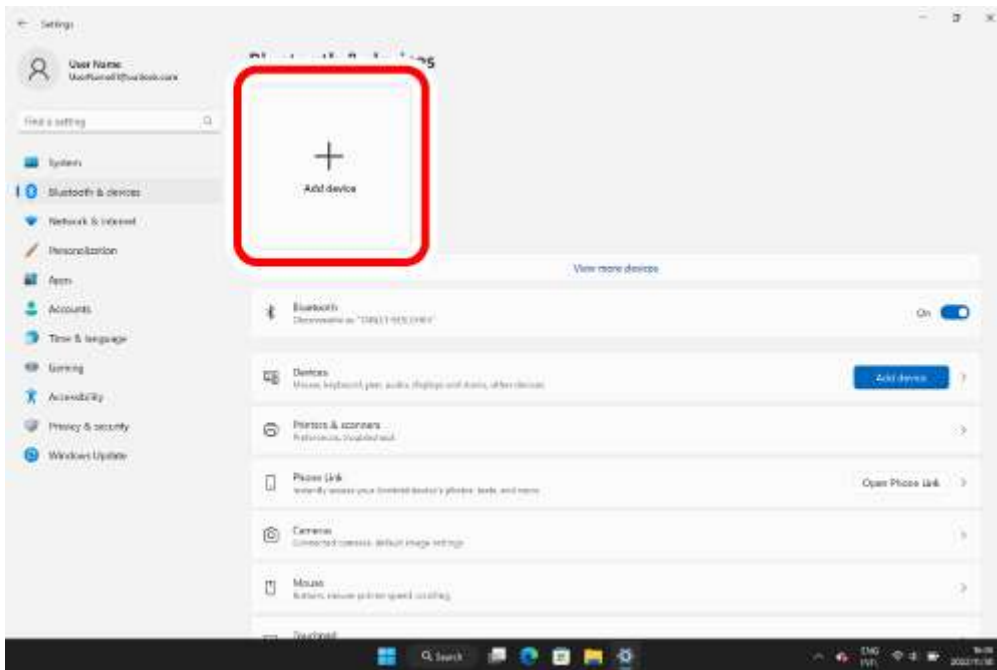

4) Press the button to switch between the connected devices.



- Please refer to **“Switch connected device”** to switch between connected devices.
- The selected connected Bluetooth device will be registered under your connected devices.

5) Click **“Bluetooth”**.



6) When the add device screen is displayed, hold down the pairing button on the underside for 3 seconds and then release.

Pairing mode will be activated and the LED will blink.

The LED will blink white when the connected device is "PC1" and green when it is "PC2".

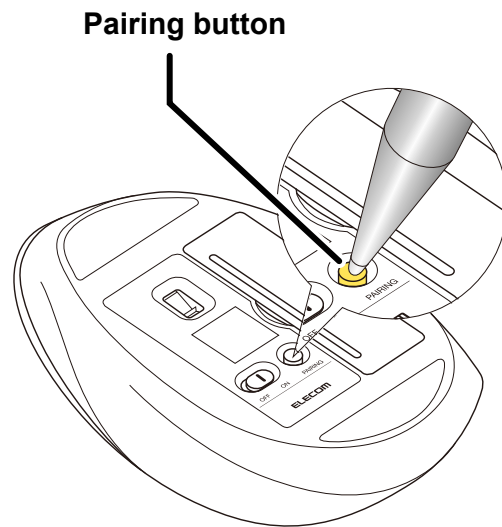

7) Click on "ELECOM OpticalMouse".

Pairing begins.

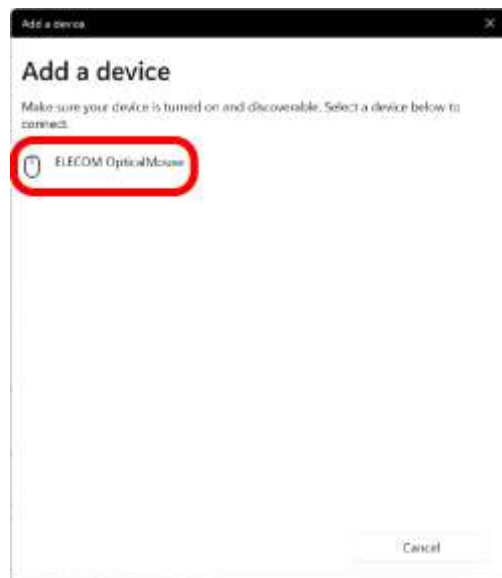

8) When the message changes to "Your device is ready to go!", click "Finish".

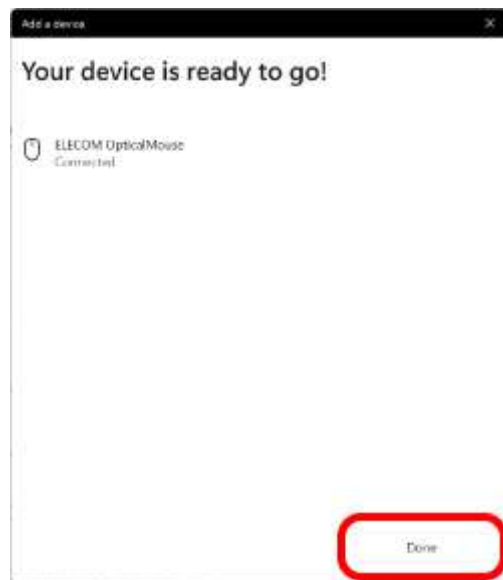

9) Pairing is complete when this product is added to “Bluetooth & devices” and the status is “Connected”.

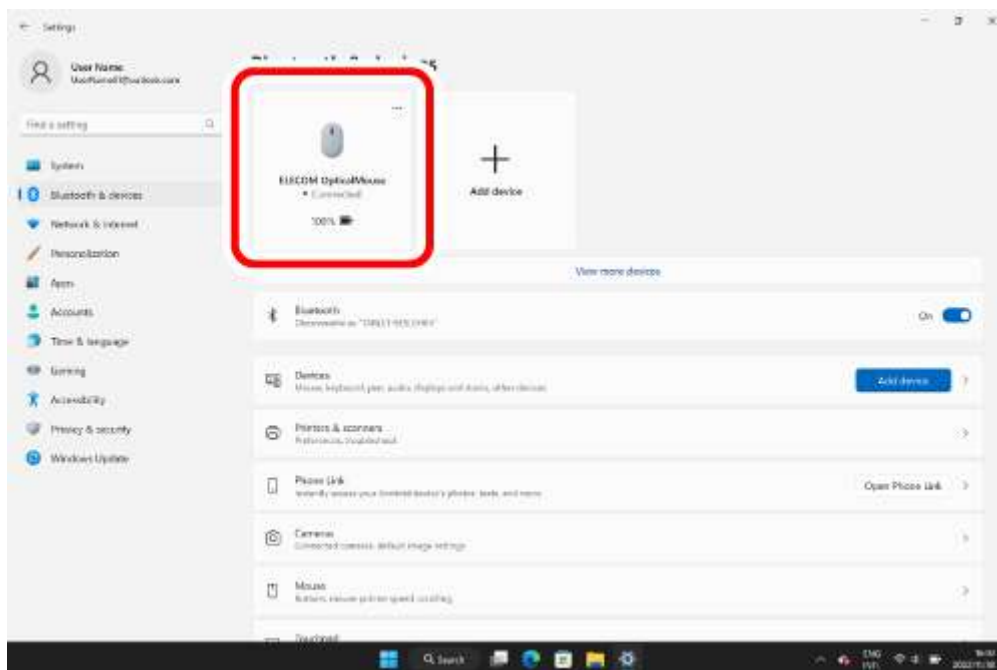

You can now use the mouse.

By downloading and installing the "ELECOM Mouse Assistant" from our company website, functions such as button assignment function and presentation mode can be used. Please proceed to ["Install ELECOM Mouse Assistant"](#).

Change the mouse pointer speed

Adjust the mouse pointer movement speed on your PC if the mouse pointer moves too fast or too slow.

■ For Windows 11

1) Click on “Start” on the bottom of the screen and click on “Settings”.

The “Settings” page will appear.

2) Click on “Bluetooth & devices” and then “Mouse”.

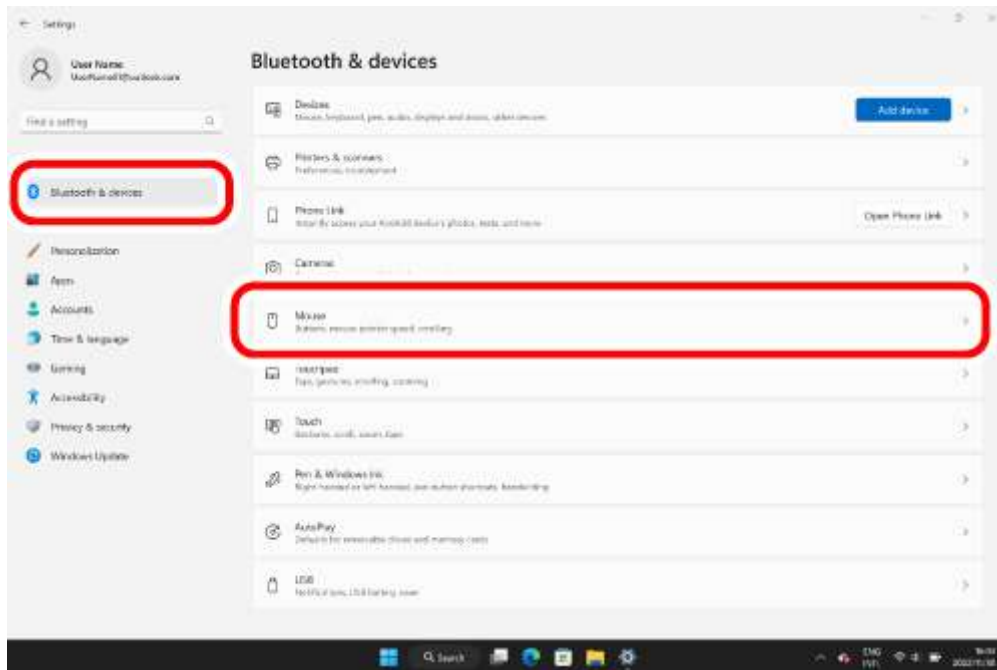

3) Adjust the “Mouse pointer speed” slider bar to adjust the mouse pointer movement speed.

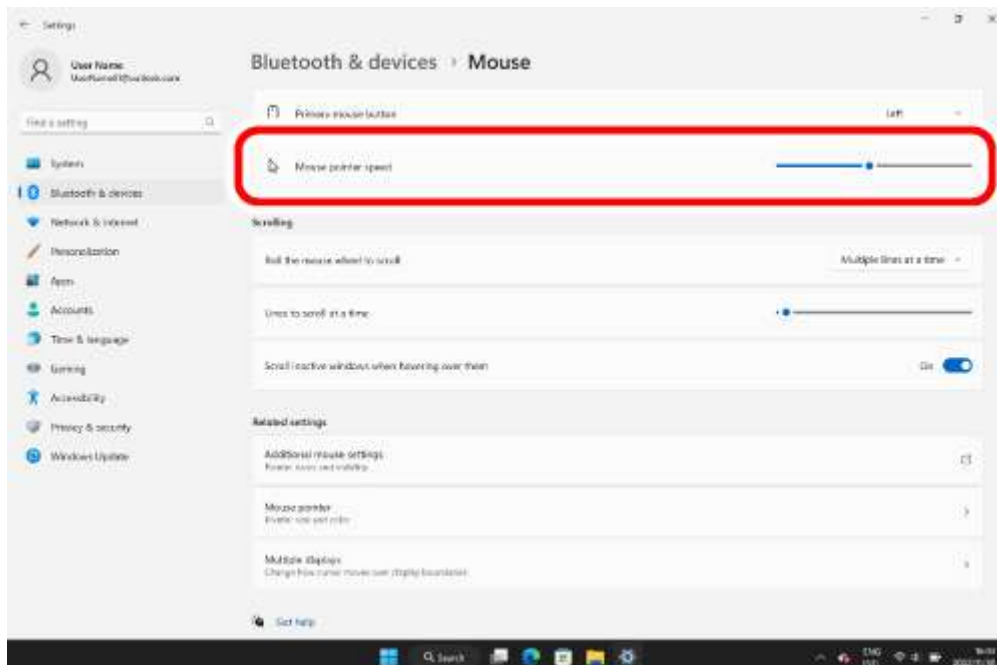

■ For Windows 10/8.1

1) Open “Mouse” properties.

• For Windows 10

From the start menu, click the Settings icon, select "Devices" → "Mouse", then click "Other mouse options" under "Related Settings".

• **For Windows 8.1**

Right-click the Start button in the bottom left-hand corner of the screen and select "Control Panel" → "Devices and Printers" → "Hardware and Sound", then click on "Mouse" under "Devices and Printers".

2) Select the "Pointer Options" tab.

3) Adjust the "Select a pointer speed" slider bar to adjust the mouse pointer movement speed.

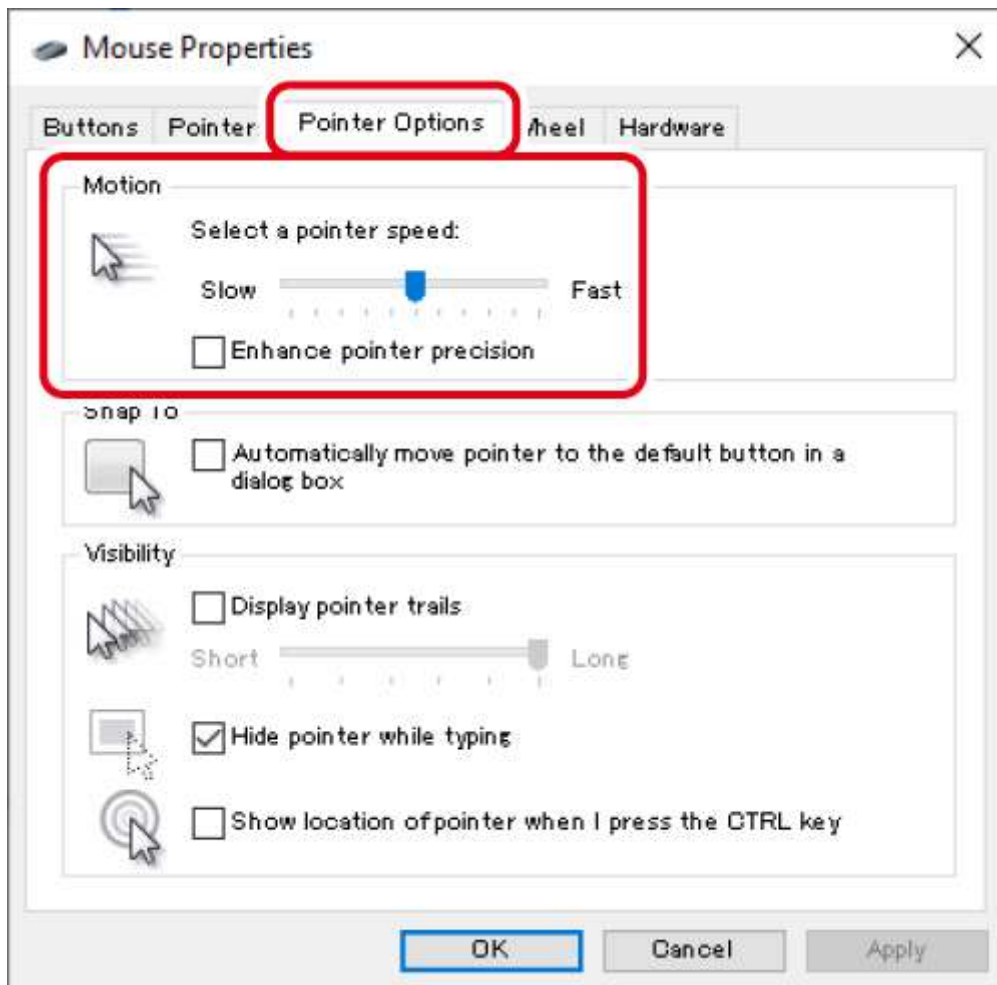

Change the number of lines scrolled in one wheel turn

■ **For Windows 11**

1) Click on "Start" on the bottom of the screen and click on "Settings".

The "Settings" page will appear.

2) Click on "Bluetooth & devices" and then "Mouse".

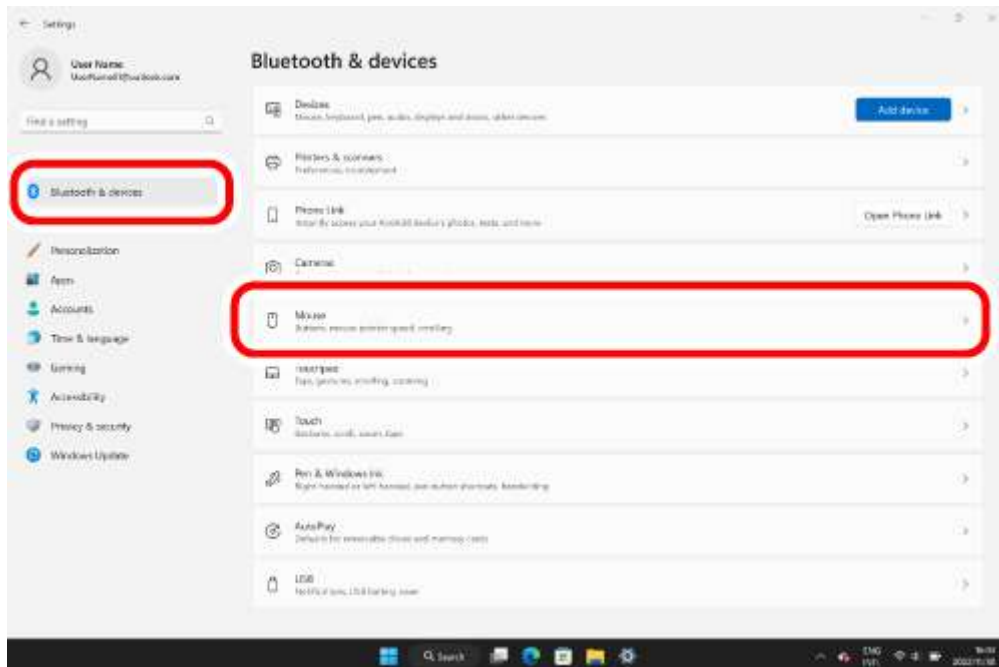

3) Adjust the “Lines to scroll at a time” slider bar to adjust the number of lines per scroll.

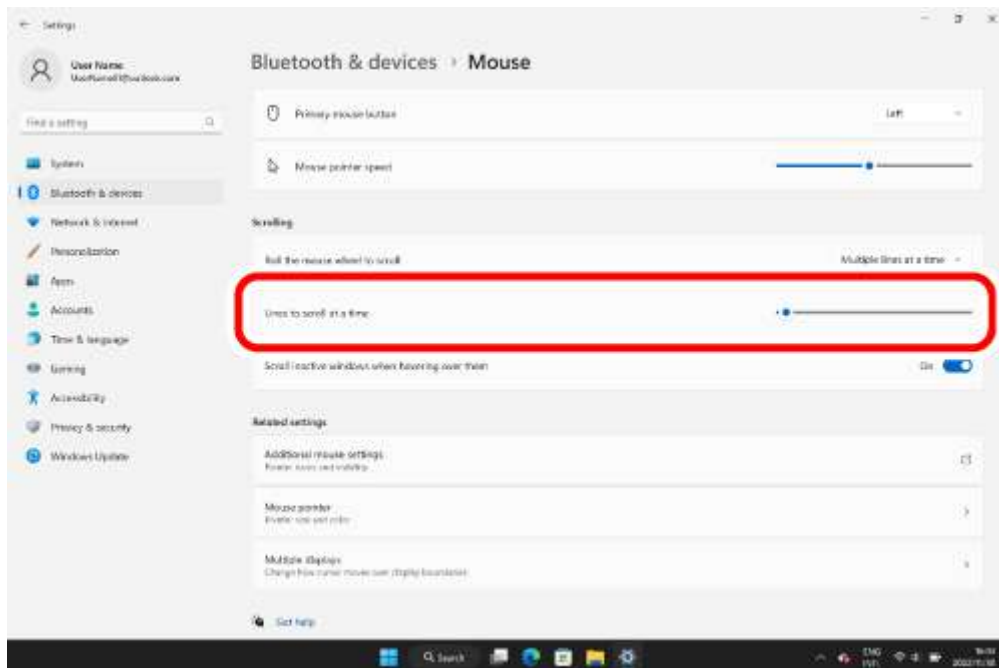

■ For Windows 10/8.1

1) Open “Mouse” properties.

• For Windows 10

From the start menu, click the Settings icon, select “Devices” → “Mouse”, then click “Other mouse options” under “Related Settings”.

• For Windows 8.1

Right-click the Start button in the bottom left-hand corner of the screen and select “Control Panel” → “Devices and Printers” → “Hardware and Sound”, then click on “Mouse” under “Devices & Printers”.

2) Select the “Wheel” tab.

3) Change the value of “The following number of lines at a time” under “Roll the wheel one notch to scroll”

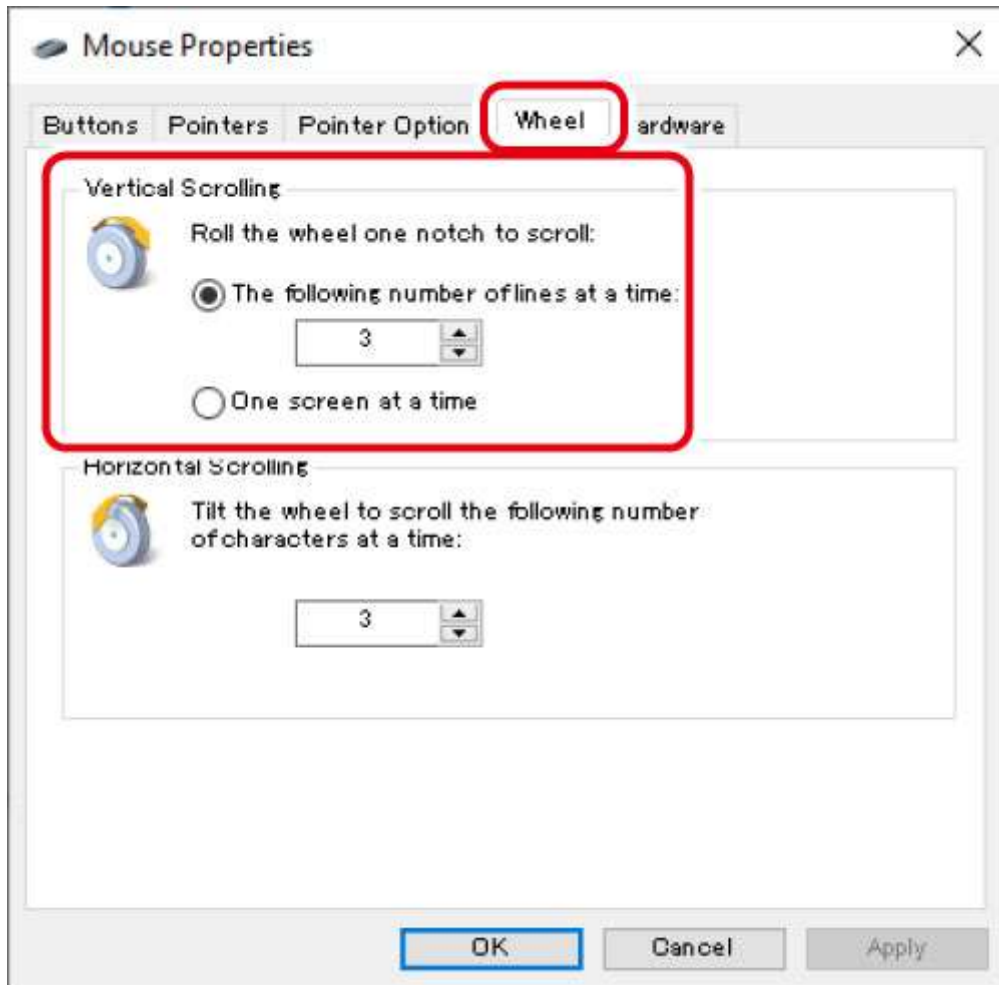

Mac



1. Turn the power ON

1) Remove the battery cover.

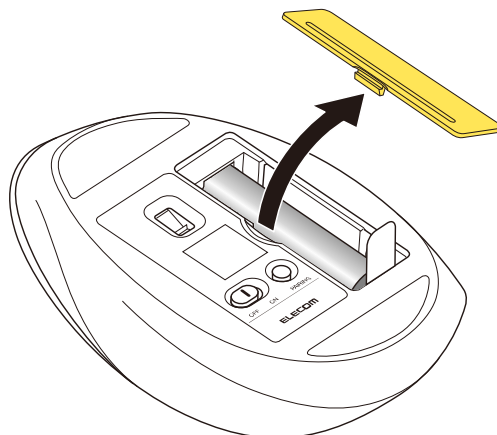

2) Remove the battery insulating tab.

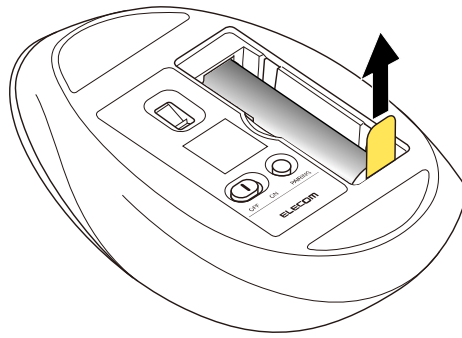

3) Put the battery cover back on.

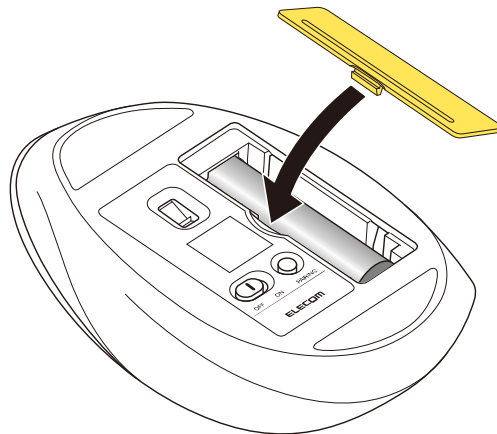

4) Slide the power switch on the underside of the product to the ON position.

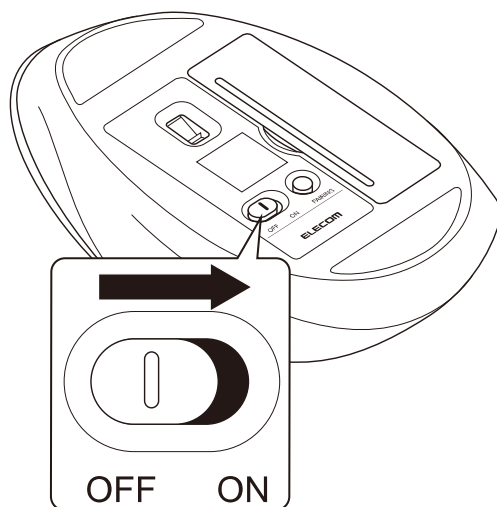

The LED will light up for a period of time.

* When the battery level is running low, the LED will blink for a period of time.



Power-saving mode

When the mouse is left untouched for a fixed period of time while the power is ON, it automatically shifts to power-saving mode.

The mouse returns from power-saving mode when it is moved.

* Mouse operation may be unstable for 2-3 seconds after returning from the power-saving mode.

Replacing the battery...

1) Remove the battery cover.

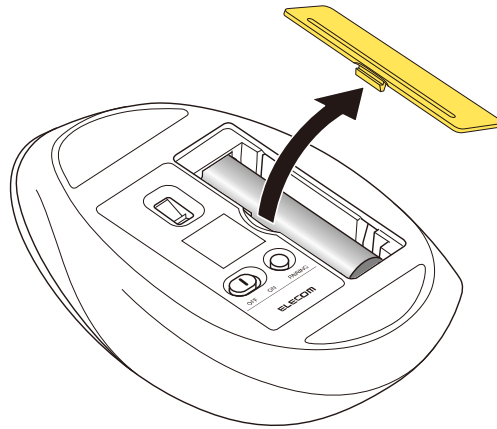

2) Remove the battery.

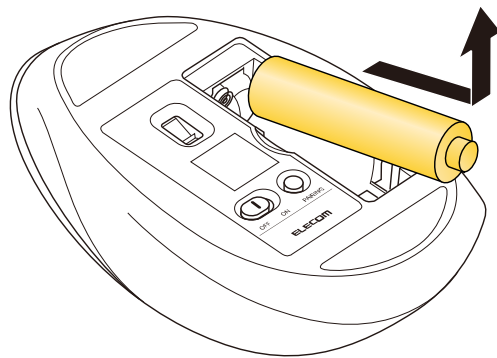

3) Insert the battery according to the instructions on the battery compartment.

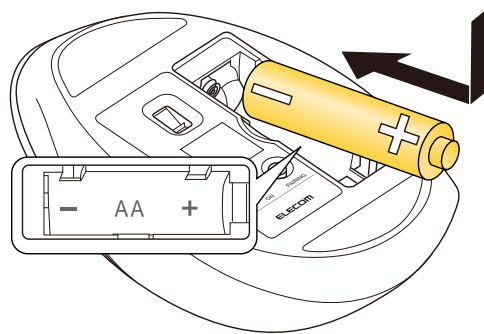

Ensure that the battery is inserted with the positive (+) and negative (-) terminals oriented correctly.

4) Put the battery cover back on.

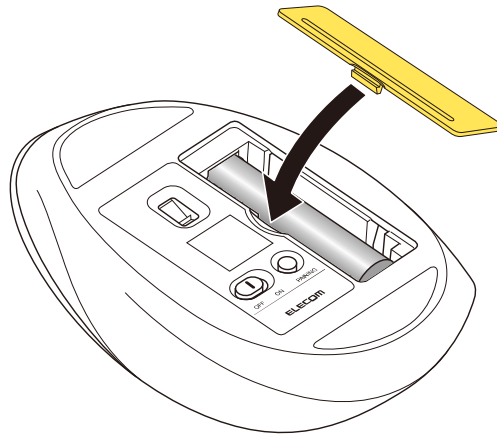

2. Pairing with a PC

- Pairing involves registering Bluetooth devices (in this case, this product and your device) with each other, and authorizing a connection between them.
- This section covers macOS standard Bluetooth functions. Depending on your device or Bluetooth adaptor, unique Bluetooth functions may be used. Please read the respective manuals for each function.
- Please carry out the pairing operation using your current mouse or touchpad on your device.
- The following instructions are for macOS Ventura (13).

1) From the Apple menu, click on “System Settings...”.

The System Settings window will appear.

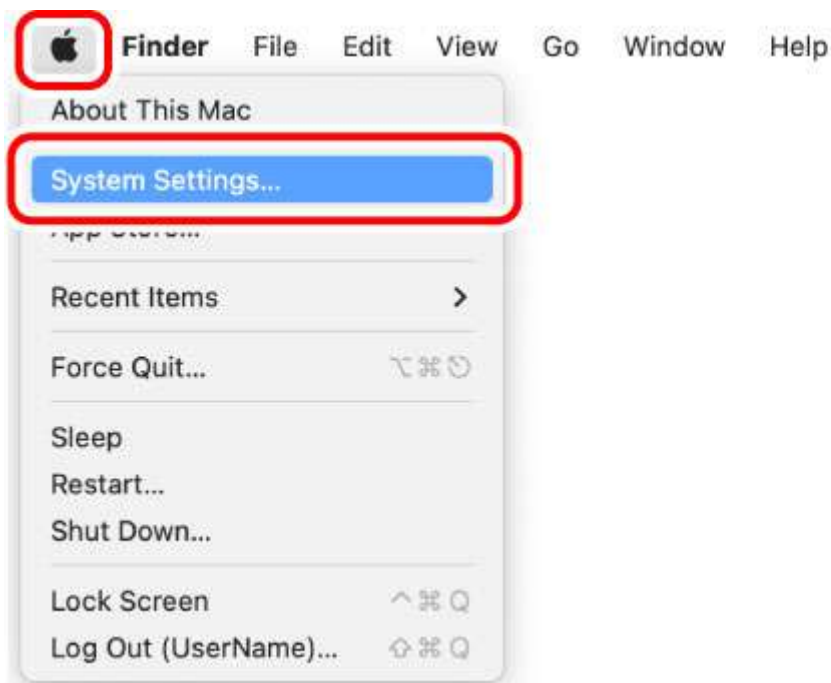

2) Click on “Bluetooth” to turn on “Bluetooth”.

The “Bluetooth” system settings page will appear.

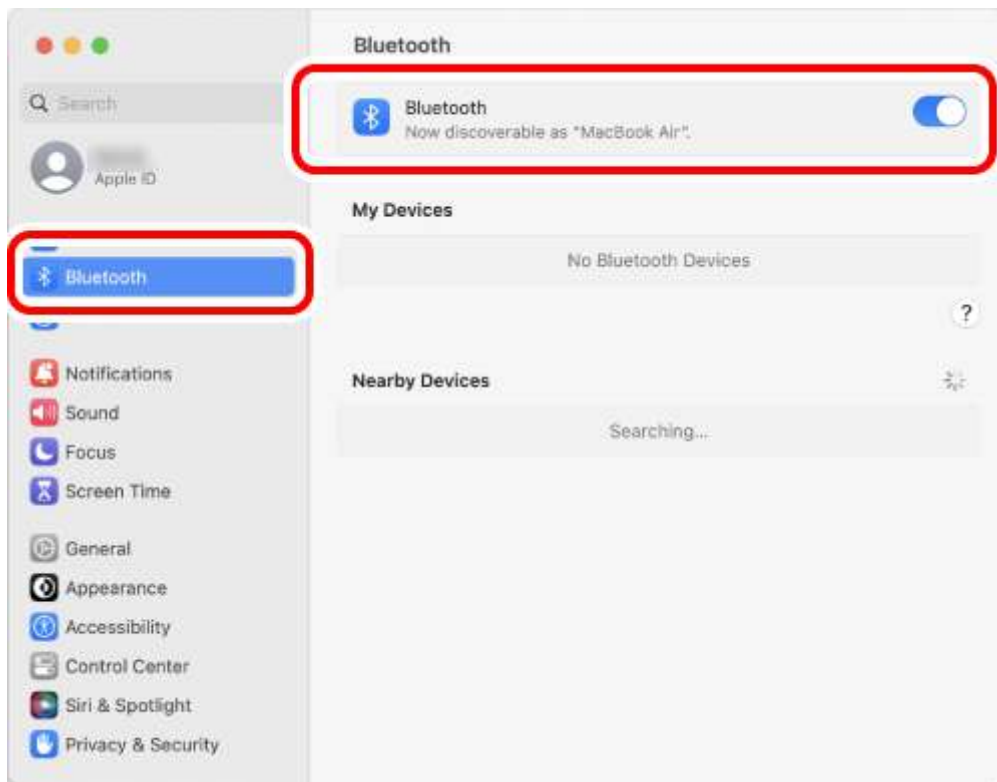

3) Press the button to switch between the connected devices.



- Please refer to **“Switch connected device”** to switch between connected devices.
- The selected connected Bluetooth device will be registered under your connected devices.

4) During the device search, hold down the pairing button on the underside for 3 seconds and then release.

Pairing mode will be activated and the LED will blink.

The LED will blink white when the connected device is "PC1" and green when it is "PC2".

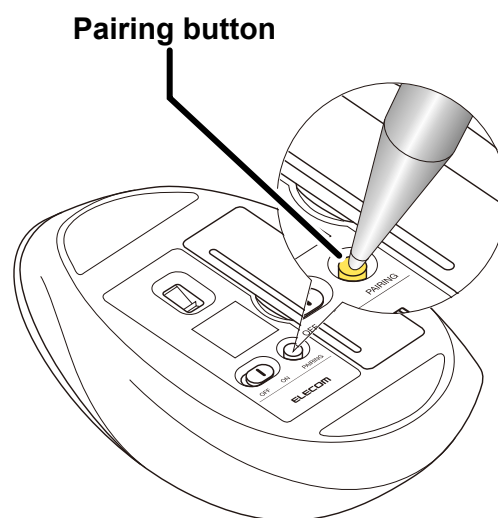

5) When "ELECOM OpticalMouse" is detected under "Nearby Devices", click "Connect".

Pairing begins.

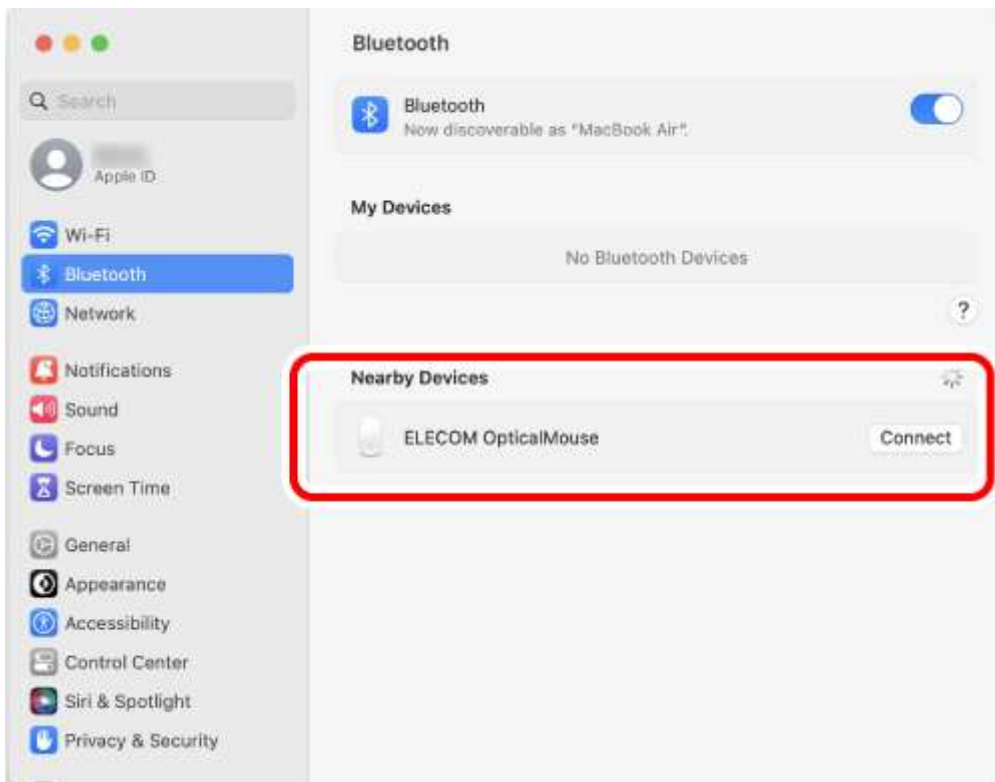

6) Pairing is complete when the status of "ELECOM OpticalMouse" changes to "Connected".

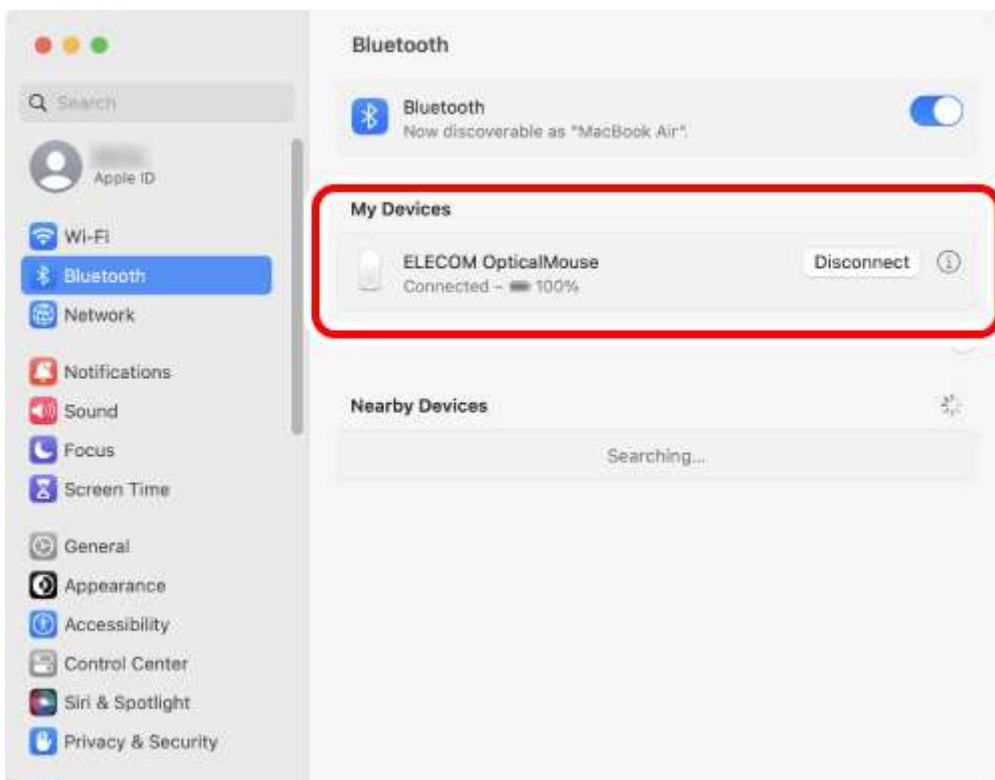

You can now use the mouse.

By downloading and installing the "ELECOM Mouse Assistant" from our company website, functions such as button assignment function and presentation mode can be used. Please proceed to "[Install ELECOM Mouse Assistant](#)".

Change the mouse pointer speed

Adjust the mouse pointer movement speed on your PC if the mouse pointer moves too fast or too slow.

1) Click "Mouse" under "System Settings".

The "Mouse" settings page will load up.

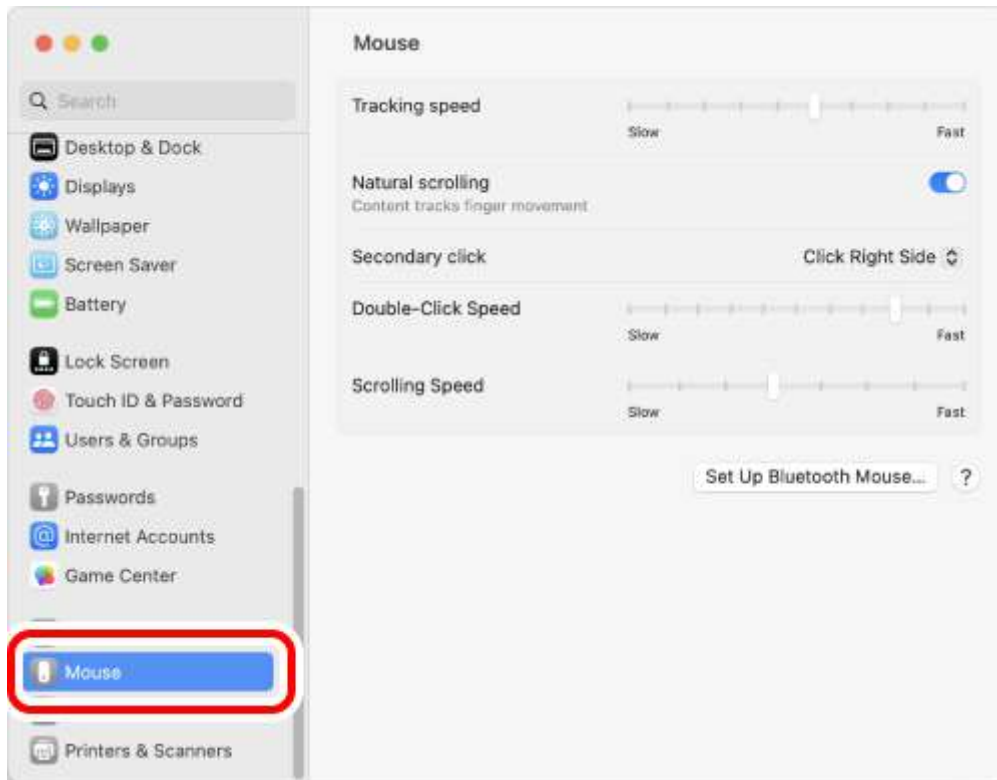

2) Adjust the "Tracking speed" slider to adjust the speed of the mouse pointer.

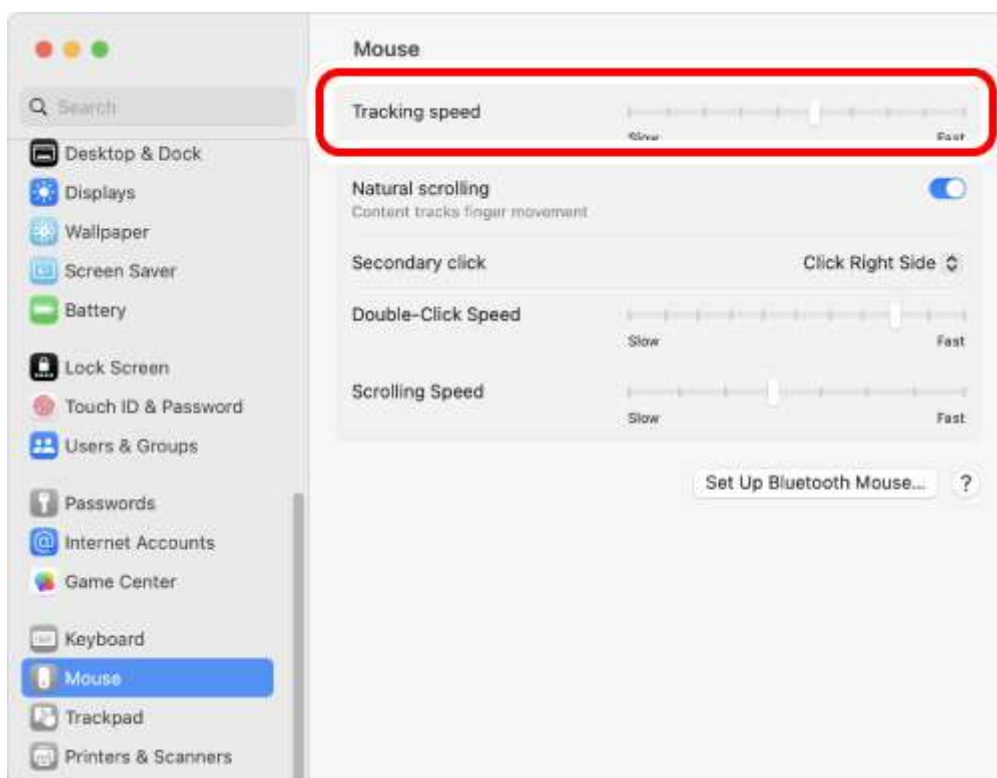



Unchecking "Natural scrolling" will cause the scroll direction to be reversed.

iPhone, iPad



1. Turn the power ON

1) Remove the battery cover.

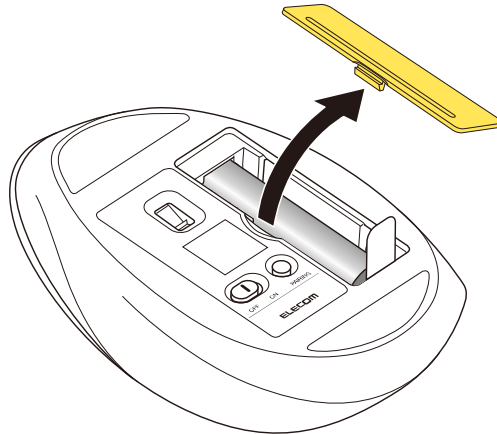

2) Remove the battery insulating tab.

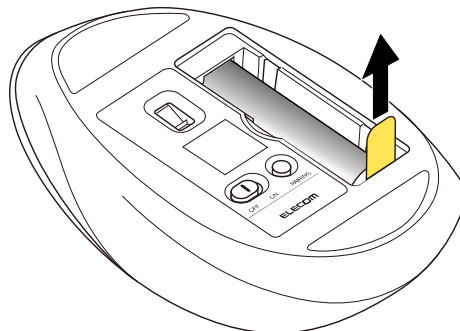

3) Put the battery cover back on.

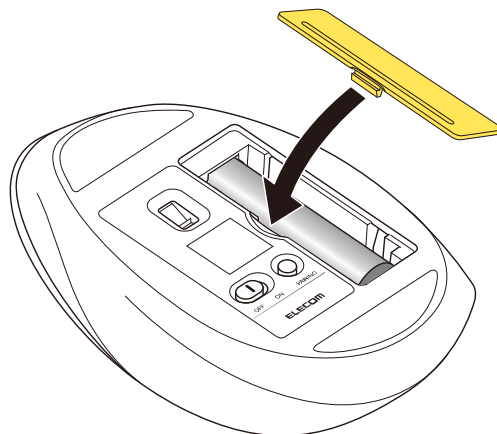

4) Slide the power switch on the underside of the product to the ON position.

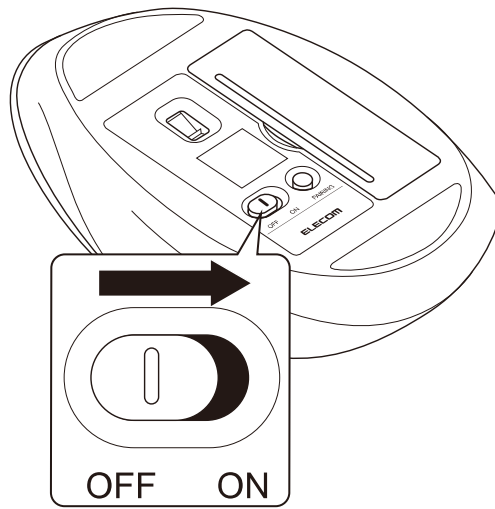

The LED will light up for a period of time.

* When the battery level is running low, the LED will blink for a period of time.



Power-saving mode

When the mouse is left untouched for a fixed period of time while the power is ON, it automatically shifts to power-saving mode.

The mouse returns from power-saving mode when it is moved.

* Mouse operation may be unstable for 2-3 seconds after returning from the power-saving mode.

Replacing the battery...

1) Remove the battery cover.

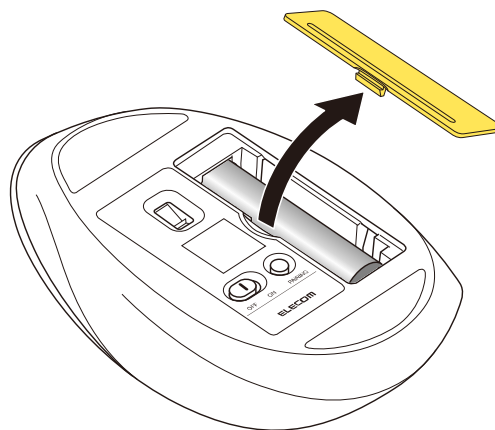

2) Remove the battery.

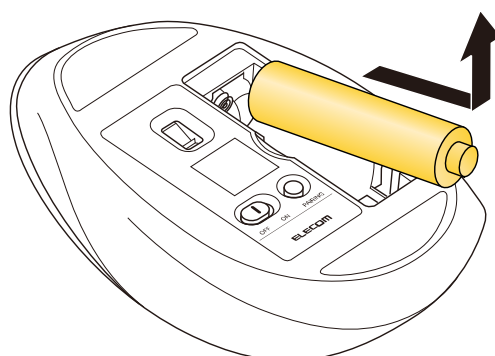

3) Insert the battery according to the instructions on the battery compartment.

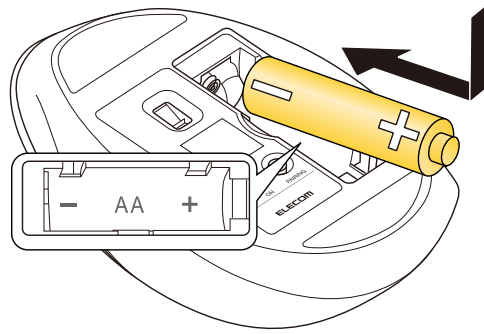

Ensure that the battery is inserted with the positive (+) and negative (-) terminals oriented correctly.

4) Put the battery cover back on.

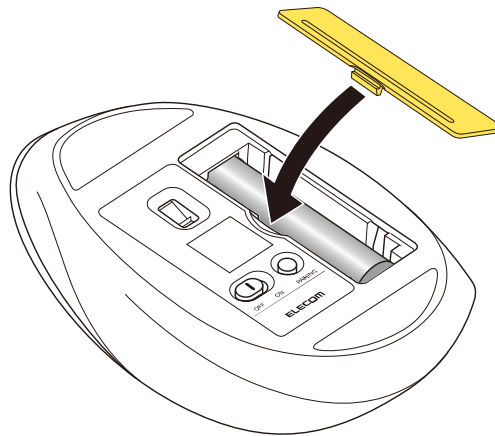

2. Pairing with an iPad or an iPhone

- Pairing involves registering Bluetooth devices (in this case, this product and an iPad or an iPhone) with each other, and authorizing a connection between them.
- Tap to operate the iPad or iPhone device until pairing is complete.
- The following instructions are for iPadOS Ver.16.11.

1) Tap on “Settings” from the home page.



2) Tap on “Bluetooth” to turn on the “Bluetooth”.

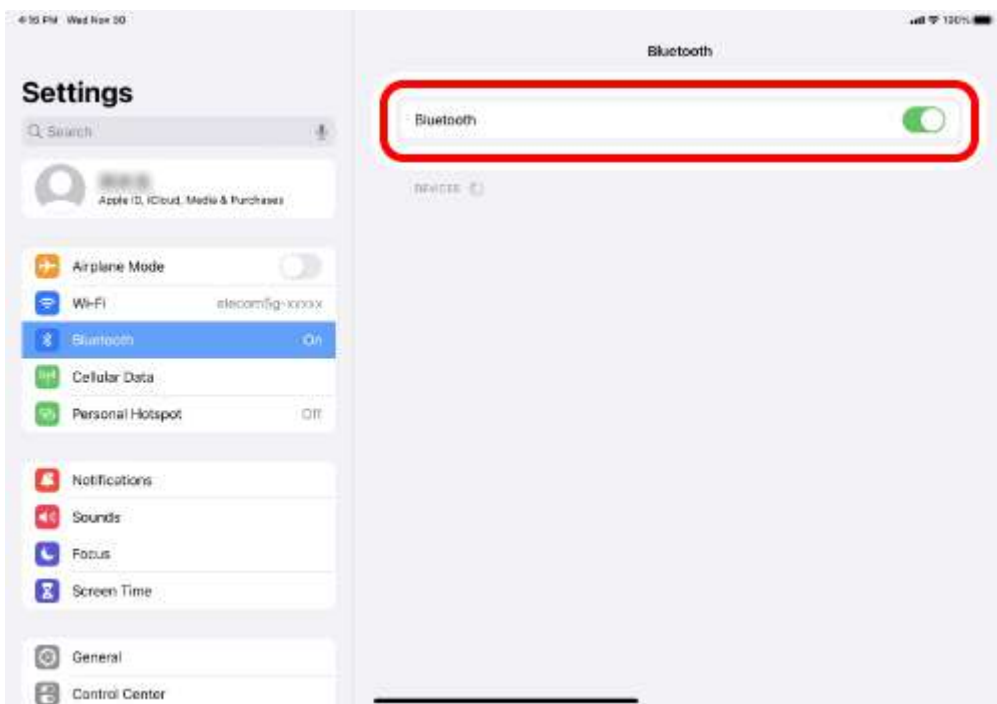

3) Press the button to switch between the connected devices.



- Please refer to “**Switch connected device**” to switch between connected devices.
- The selected connected Bluetooth device will be registered under your connected devices.

4) During the device search, hold down the pairing button on the underside for 3 seconds and then release.

Pairing mode will be activated and the LED will blink.

The LED will blink white when the connected device is "PC1" and green when it is "PC2".

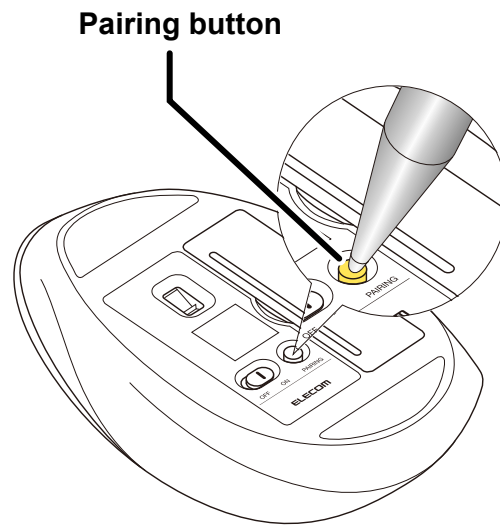

5) Tap on "ELECOM OpticalMouse" when it is detected under "Devices".

Pairing begins.

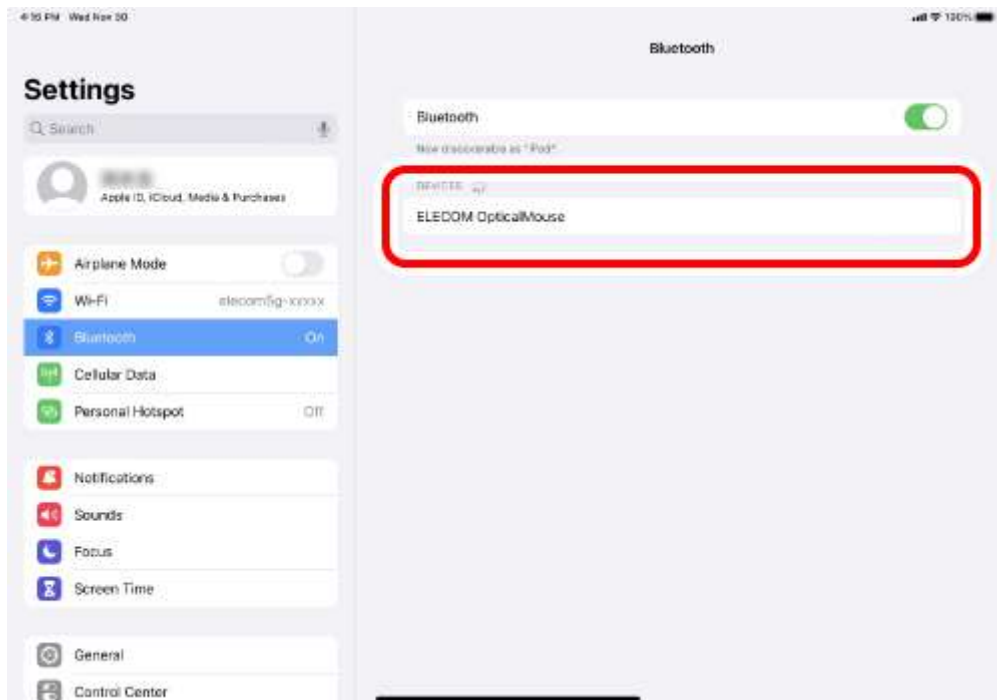

6) When the "Bluetooth pairing requirements" page loads, tap on "Pairing".

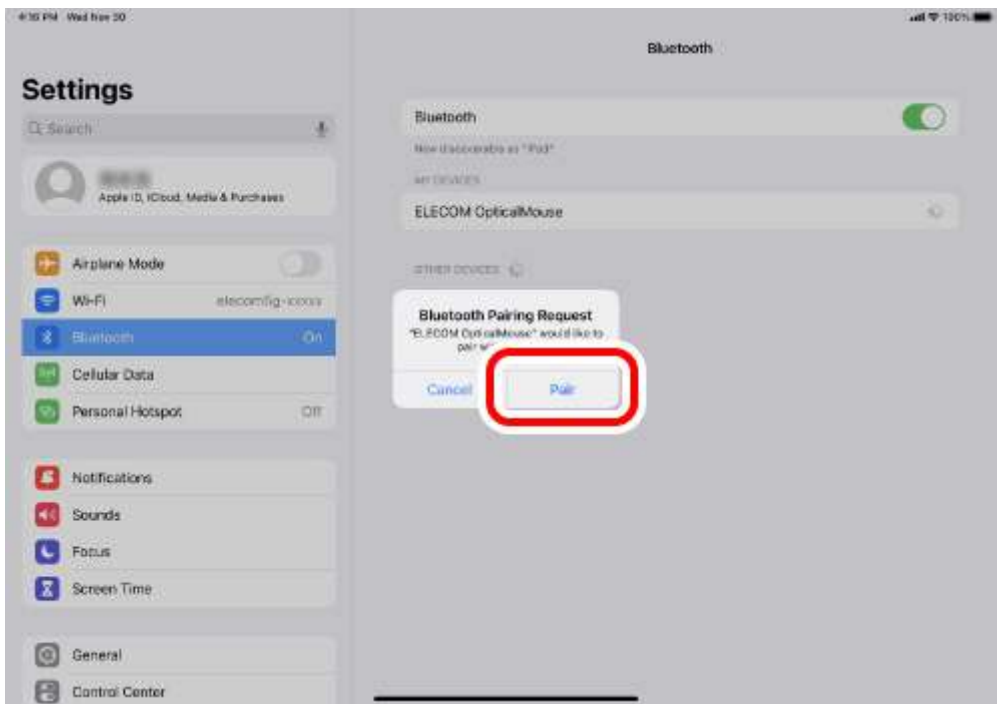

7) When the status is "Connected", the mouse is connected.

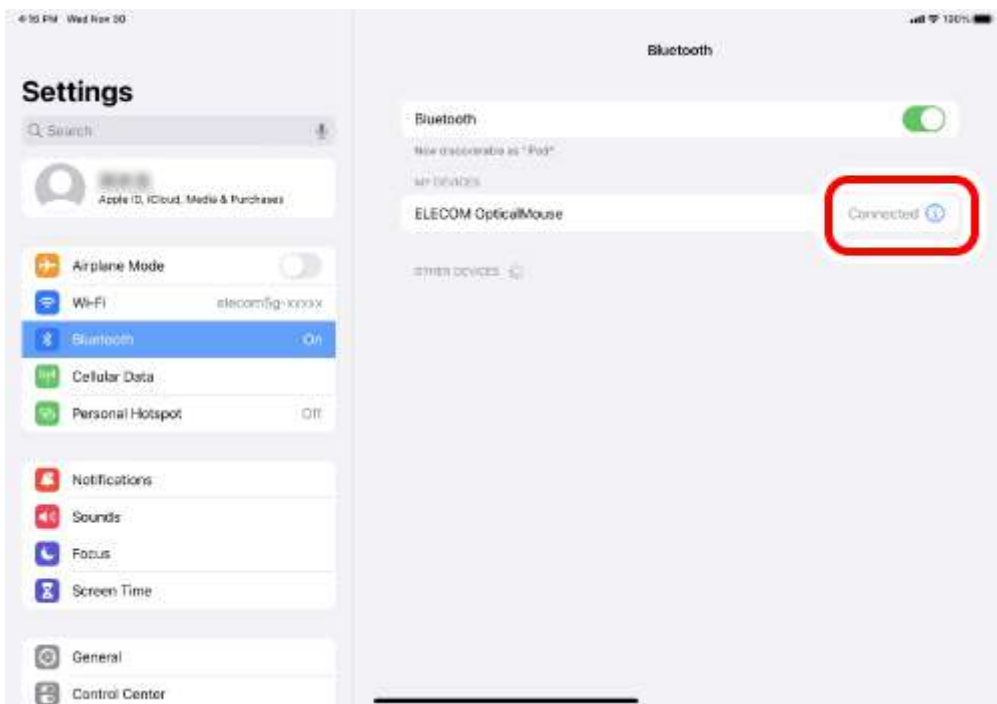

You can now use the mouse.

Register custom actions to the buttons.

Only the 2 buttons and the wheel can be used under the initial settings.

- Button 1: Single click
- Button 2: Secondary click

Follow the steps below to assign all other button functions.

1. Turn ON AssistiveTouch.

1) Tap on "Accessibility" under "Settings".

2) Tap on "Touch".

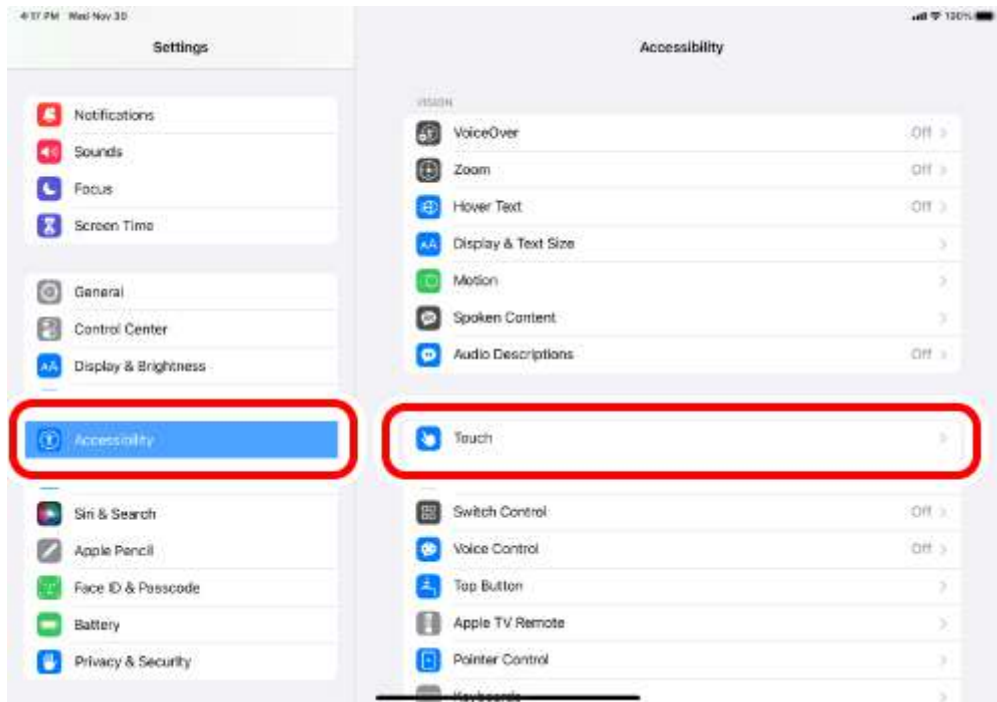

3. Tap on "AssistiveTouch".

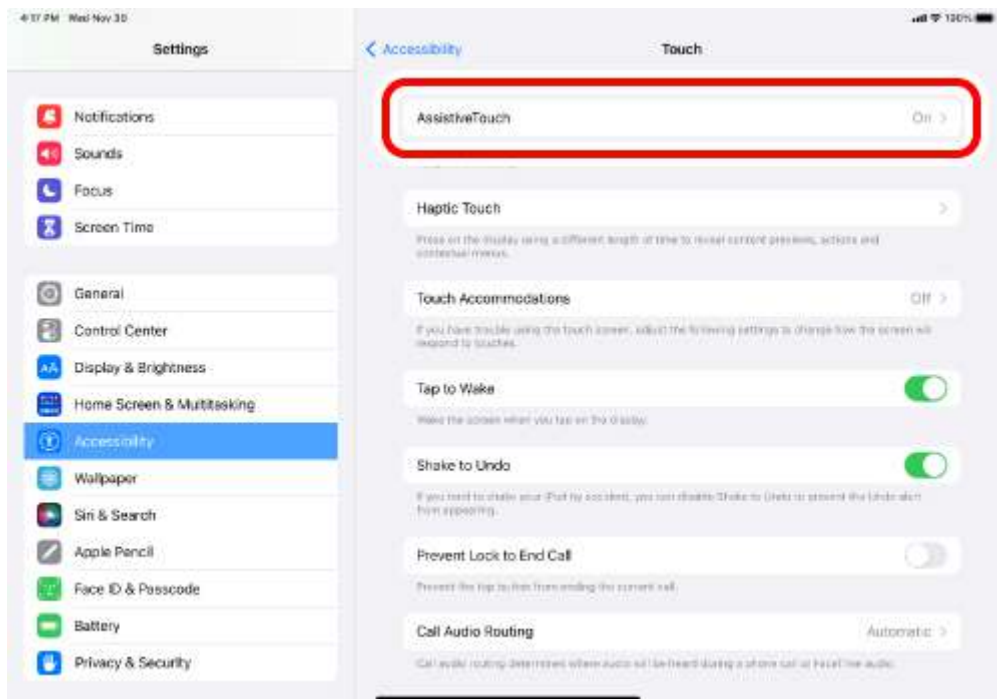

4. Tap on "AssistiveTouch" to turn ON.

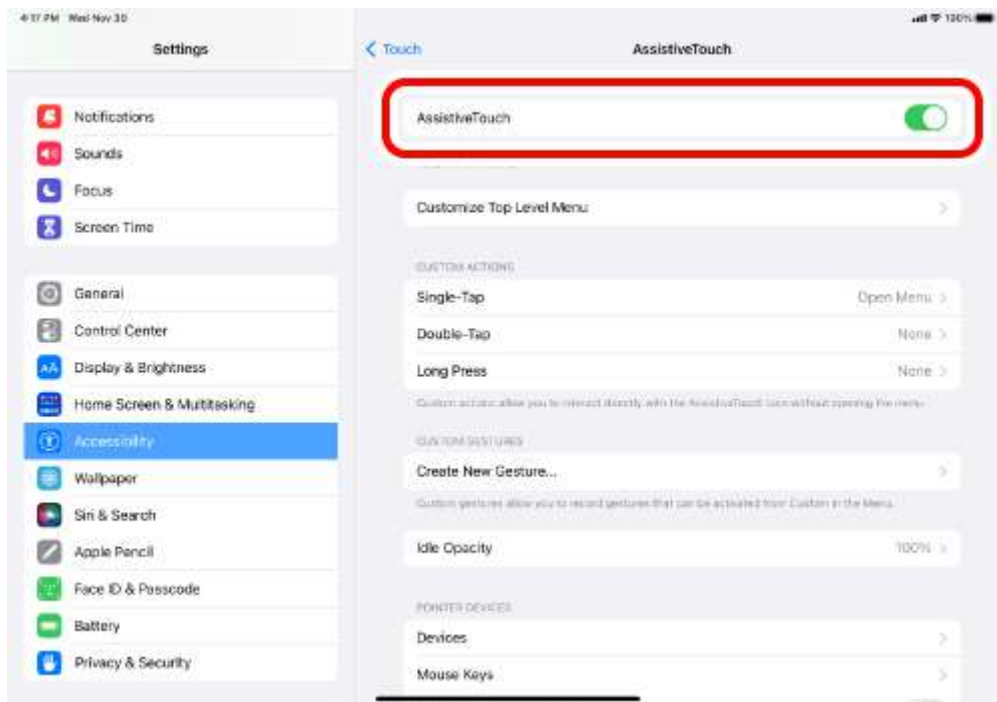

2. Assign custom actions to the buttons.

1) Tap on "Devices" under "Pointing devices".

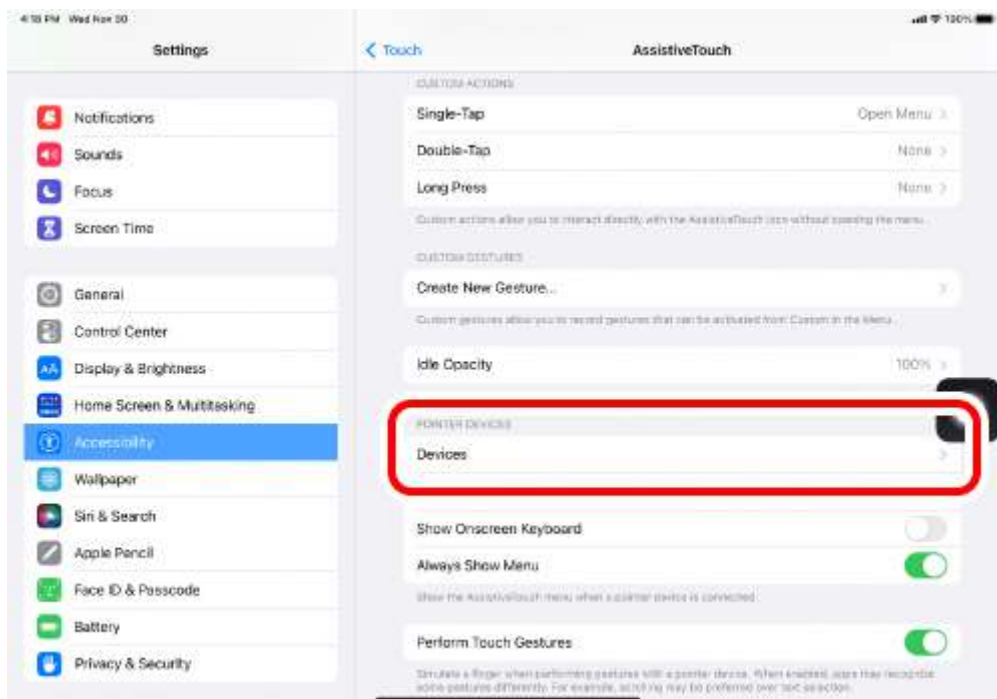

2) Tap on "ELECOM OpticalMouse".

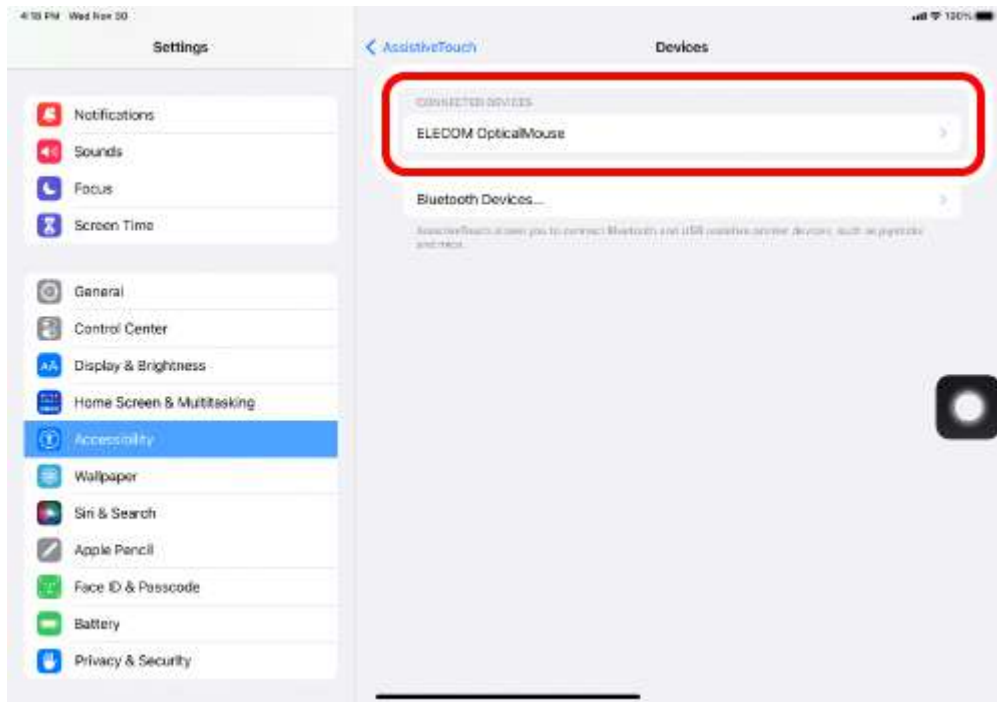

3) Tap on “Customize additional buttons...”.

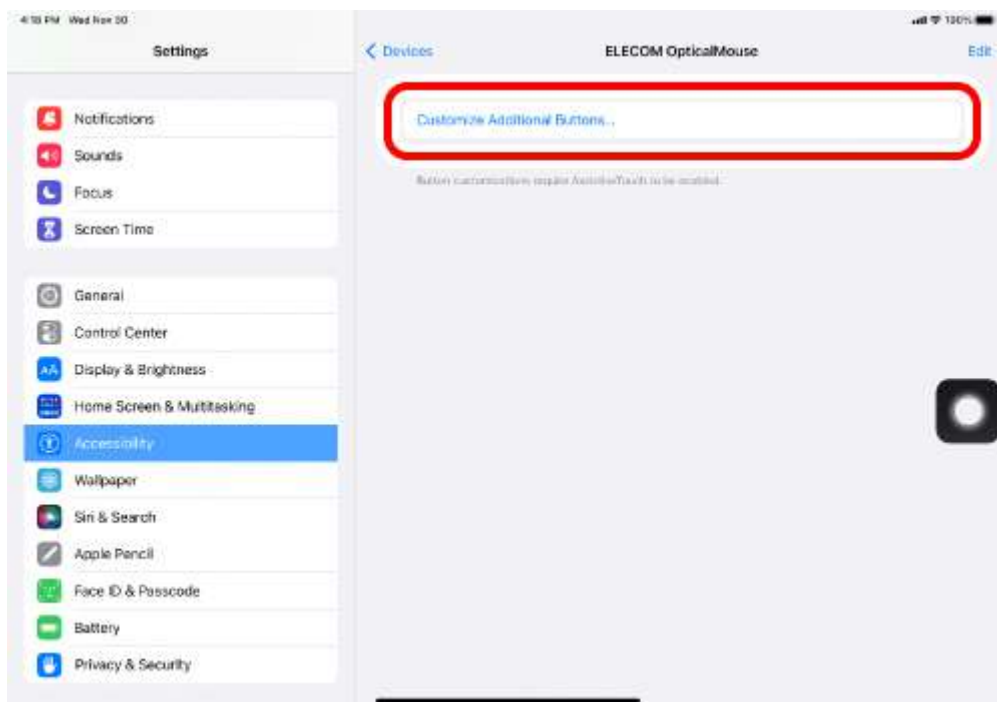

4) When the “Customize button” page loads, click on the button on the mouse to be added.

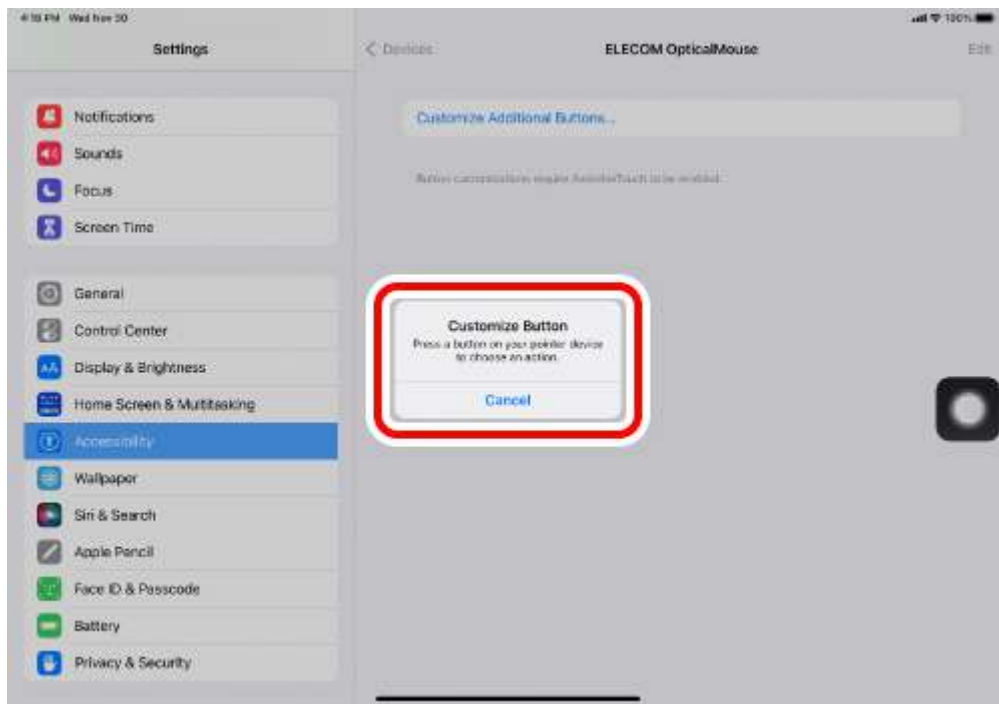

* When adding "Button 3".

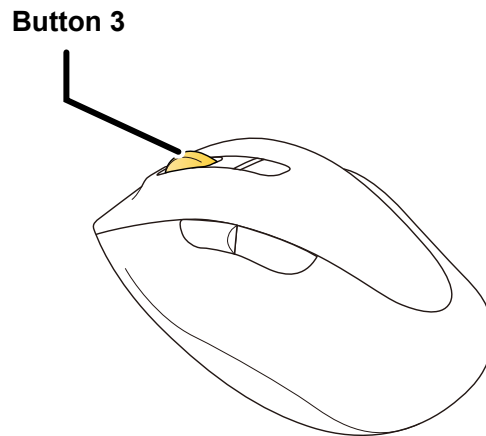

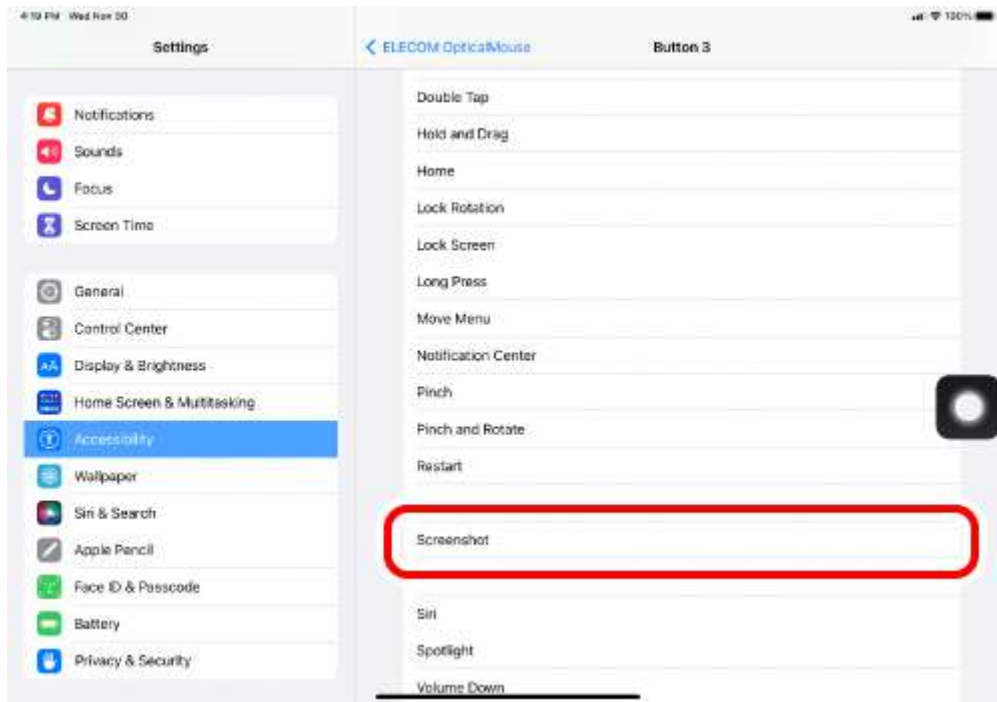

5) A list of all assignable functions will load. Tap on the desired function to assign.

* When assigning "Screenshot" to "Button 3".

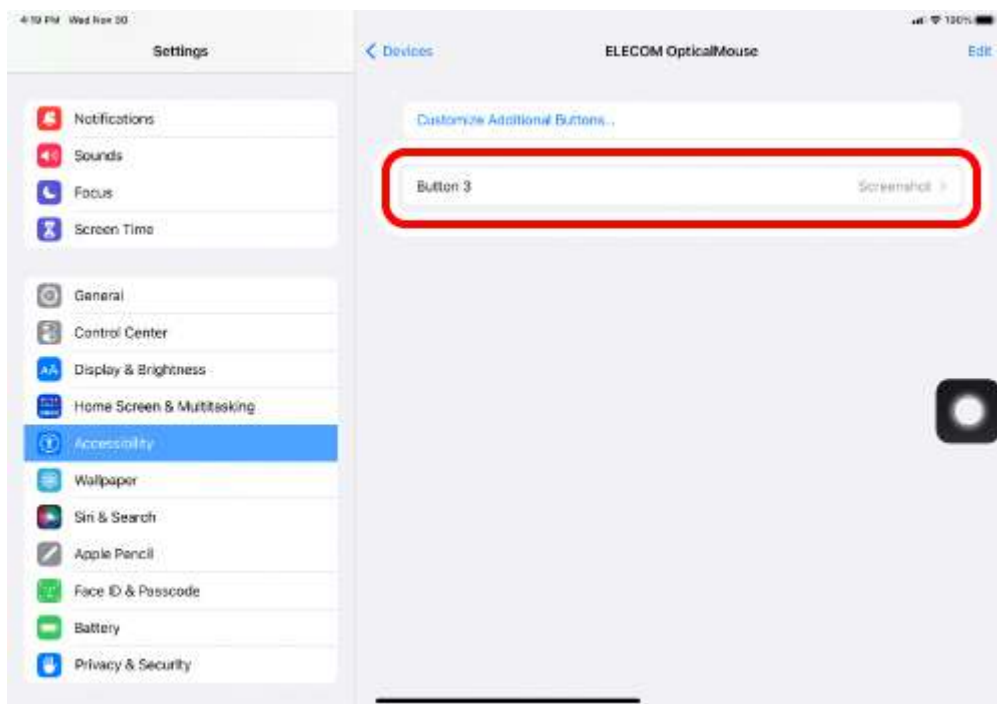

6) A function is assigned to the button. To assign other buttons, repeat the steps above.



 When AssistiveTouch is OFF, the Custom Action function is disabled and only the initial right click, left click and wheel scroll functions may be used.

Android



1. Turn the power ON

1) Remove the battery cover.

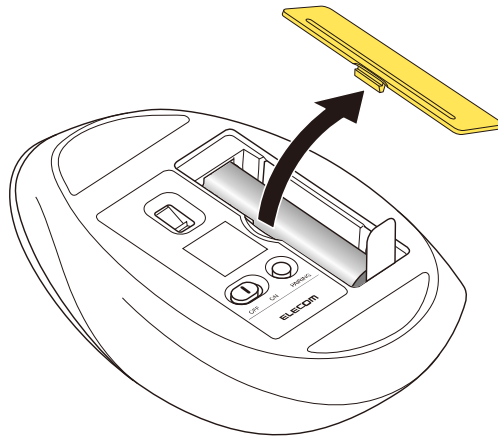

2) Remove the battery insulating tab.

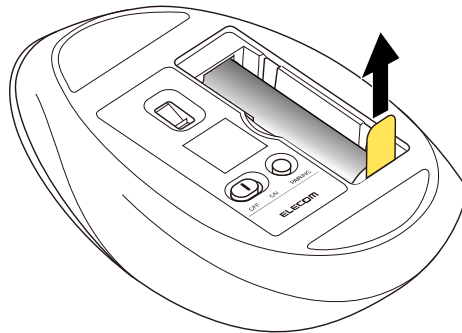

3) Put the battery cover back on.

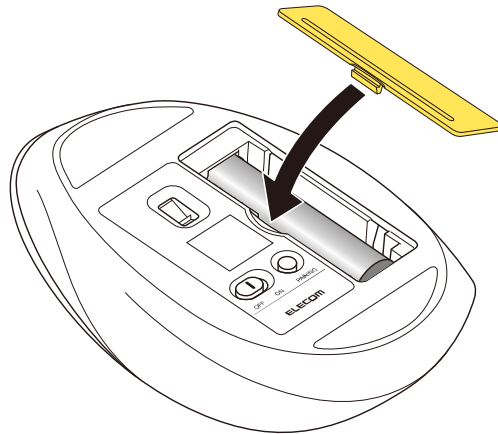

4) Slide the power switch on the underside of the product to the ON position.

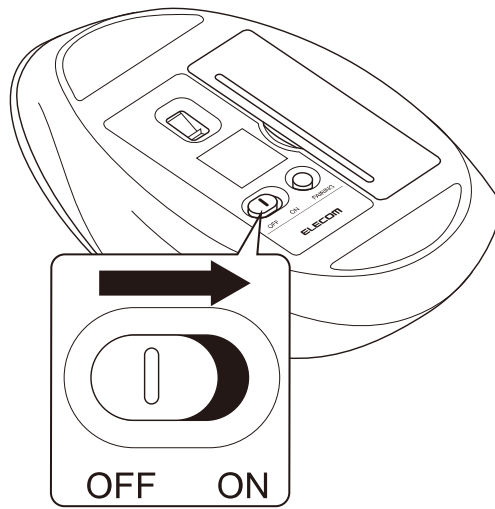

The LED will light up for a period of time.

* When the battery level is running low, the LED will blink for a period of time.



Power-saving mode

When the mouse is left untouched for a fixed period of time while the power is ON, it automatically shifts to power-saving mode.

The mouse returns from power-saving mode when it is moved.

* Mouse operation may be unstable for 2-3 seconds after returning from the power-saving mode.

Replacing the battery...

1) Remove the battery cover.

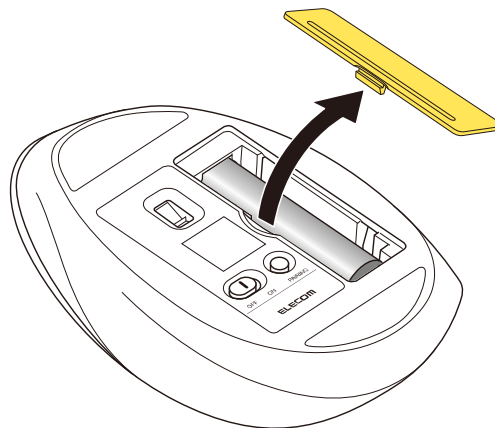

2) Remove the battery.

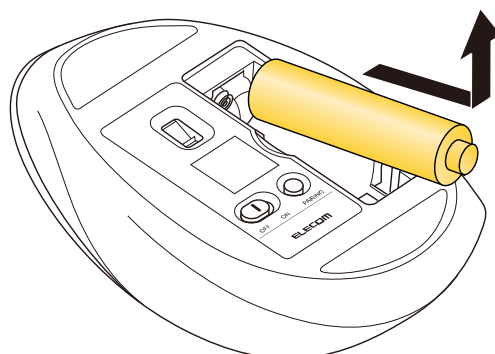

3) Insert the battery according to the instructions on the battery compartment.

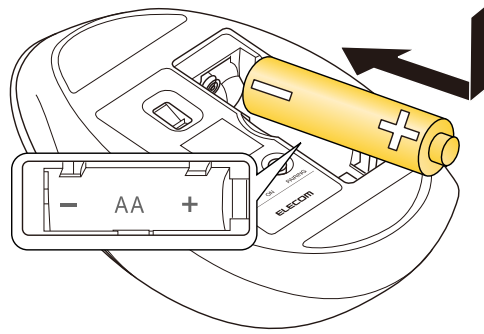

Ensure that the battery is inserted with the positive (+) and negative (-) terminals oriented correctly.

4) Put the battery cover back on.

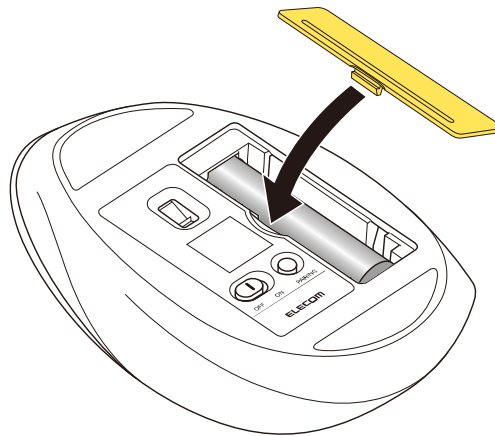

2. Pairing with an Android device.

- Pairing involves registering Bluetooth devices (in this case, this product and an Android device) with each other, and authorizing a connection between them.
- Tap to operate the Android device until pairing is complete.
- Instructions for Galaxy Tab A7 Lite (Android 12) are as follows. There may be differences depending on the OS version or device.

1) Tap on "Settings".

2) Tap on "Connections".

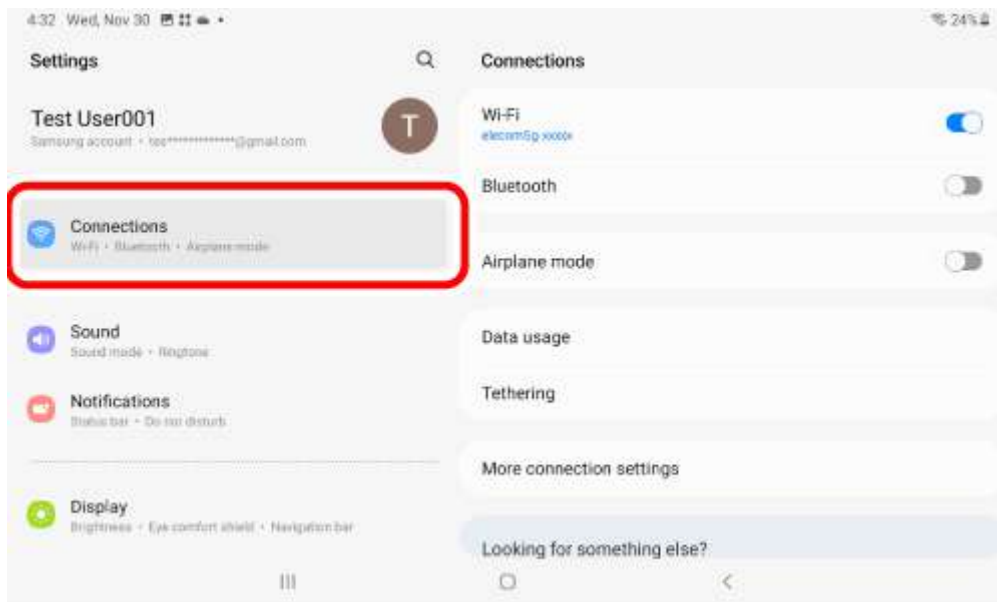

3) Tap on "Bluetooth".

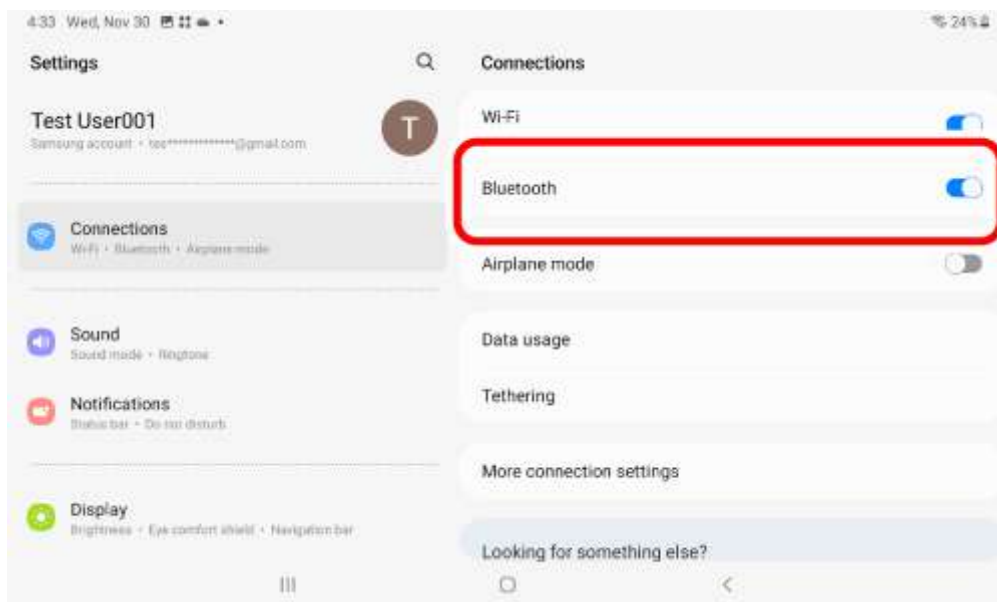

4) Check that "Bluetooth" is enabled.

If unavailable, tap to enable.

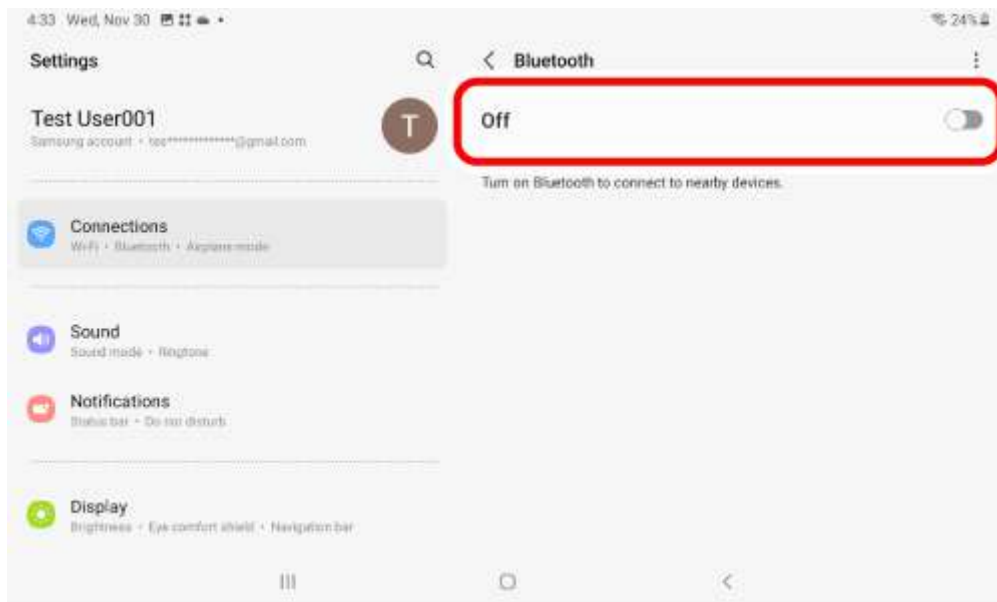

5) Slide the switch to switch between the connected devices.



- Please refer to **“Switch connected device”** to switch between connected devices.
- The selected connected Bluetooth device will be registered under your connected devices.

6) Hold down the pairing button at the bottom of the product for 3 seconds and then release.

Pairing mode will be activated and the LED will blink.

The LED will blink white when the connected device is "PC1" and green when it is "PC2".

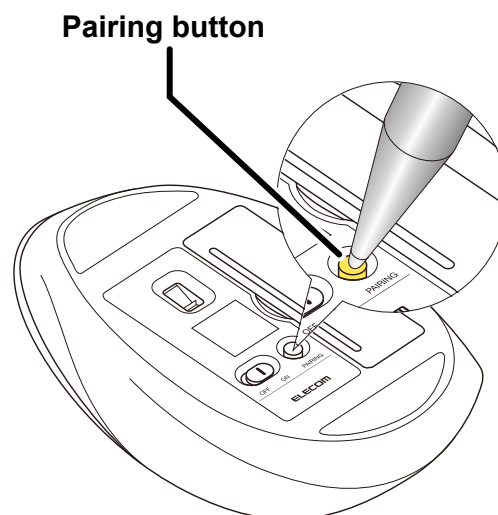

7) Tap on “Scan”.

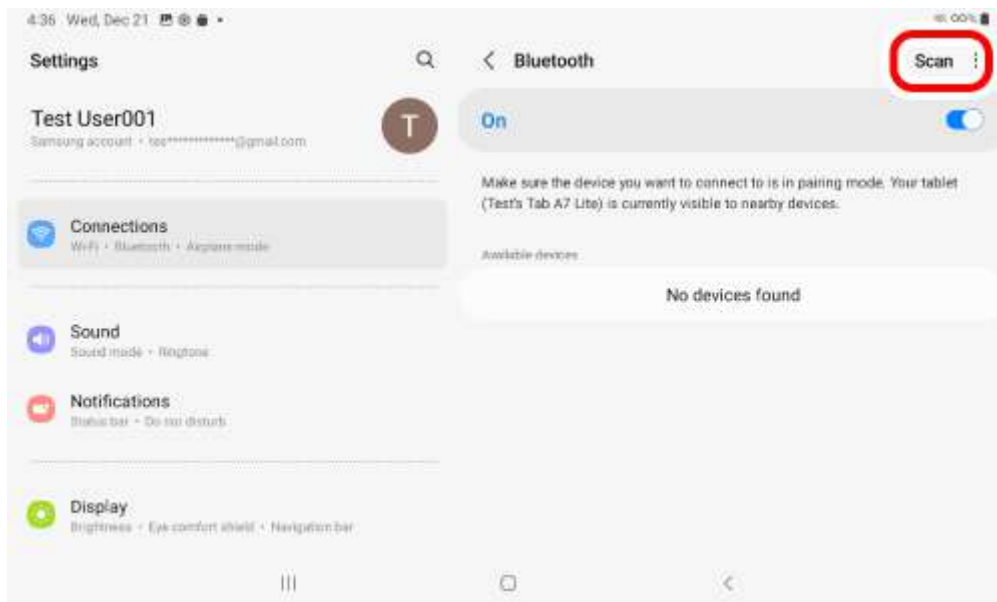

8) Tap on "ELECOM OpticalMouse" when it is detected under "Available devices".

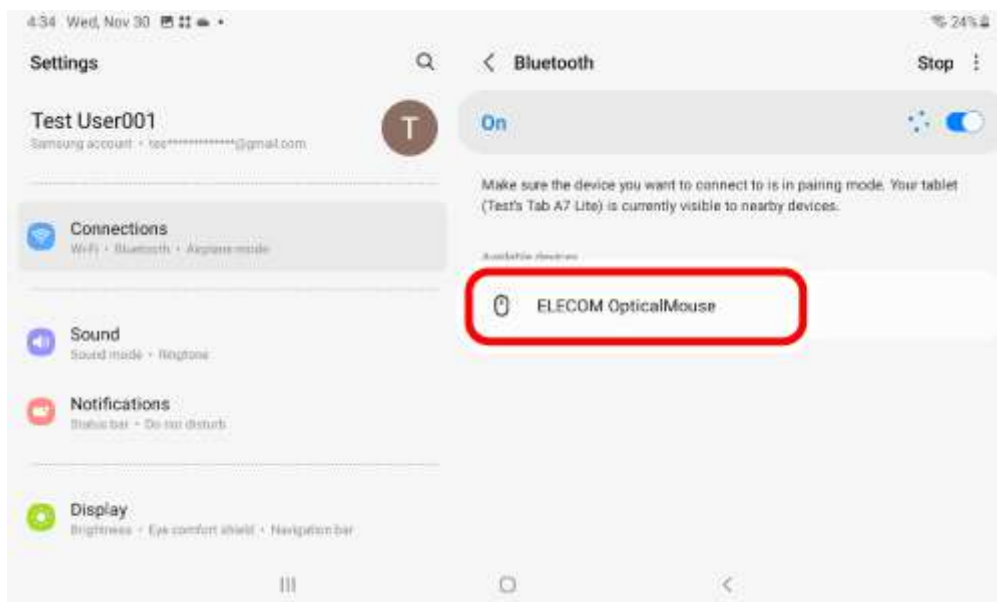

9) Tap on "Pair".

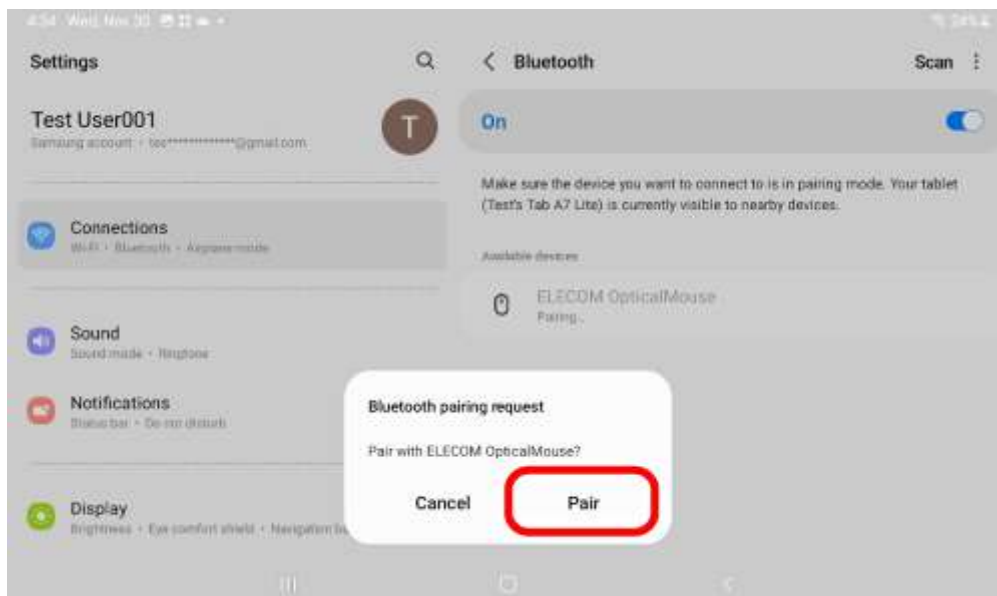

Pairing begins.

10) Pairing is complete when this product is added to “Paired devices” and the status is “Connected”.

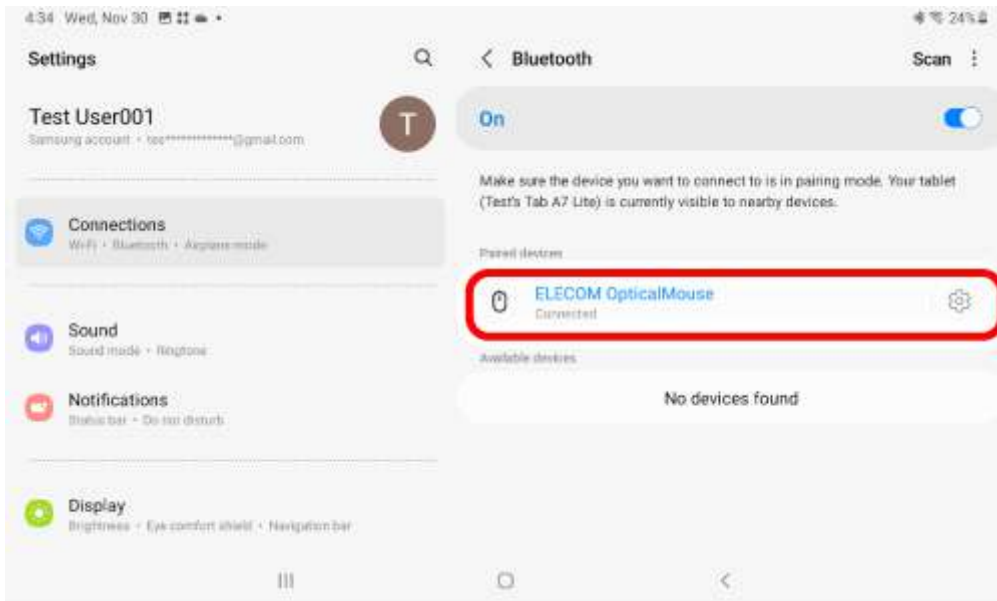

You can now use the mouse.

Chrome OS



1. Turn the power ON

1) Remove the battery cover.

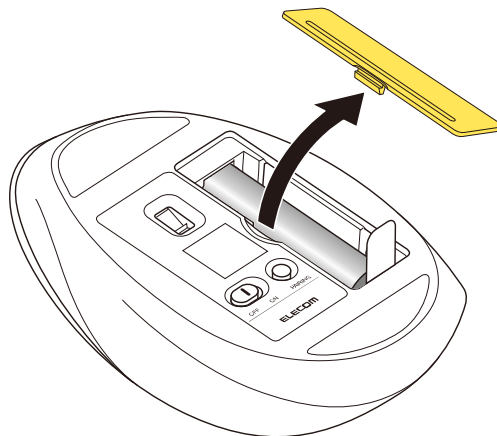

2) Remove the battery insulating tab.

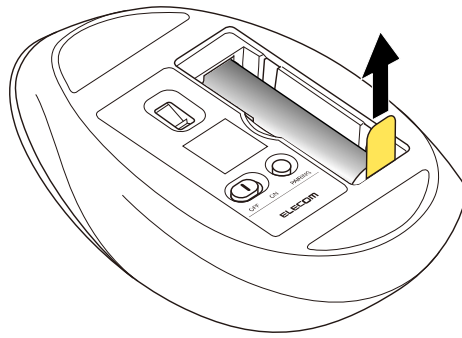

3) Put the battery cover back on.

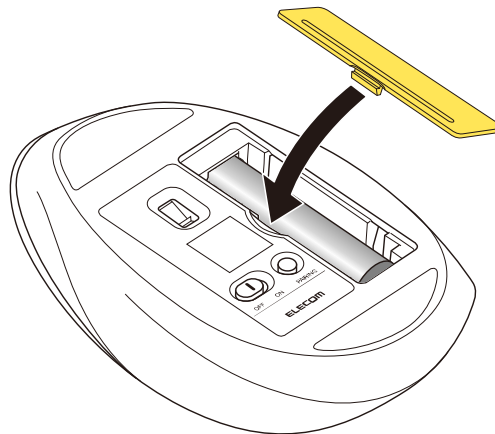

4) Slide the power switch on the underside of the product to the ON position.

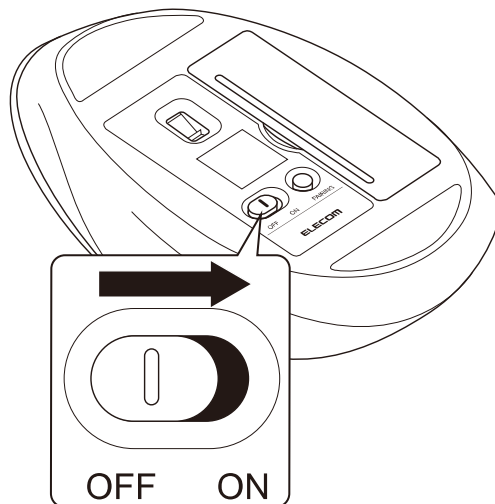

The LED will light up for a period of time.

* When the battery level is running low, the LED will blink for a period of time.



Power-saving mode

When the mouse is left untouched for a fixed period of time while the power is ON, it automatically shifts to power-saving mode.

The mouse returns from power-saving mode when it is moved.

* Mouse operation may be unstable for 2-3 seconds after returning from the power-saving mode.

Replacing the battery...

1) Remove the battery cover.

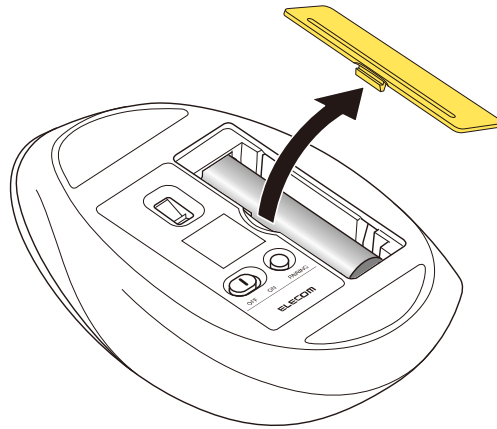

2) Remove the battery.

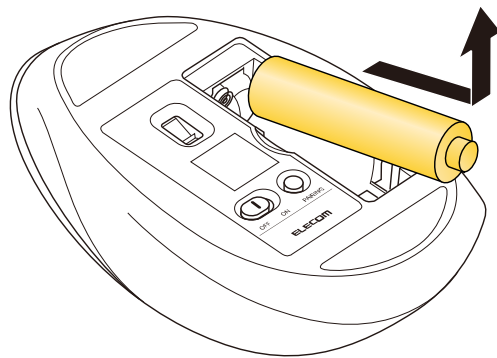

3) Insert the battery according to the instructions on the battery compartment.

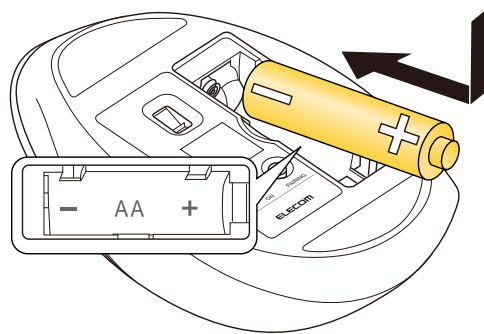

Ensure that the battery is inserted with the positive (+) and negative (-) terminals oriented correctly.

4) Put the battery cover back on.

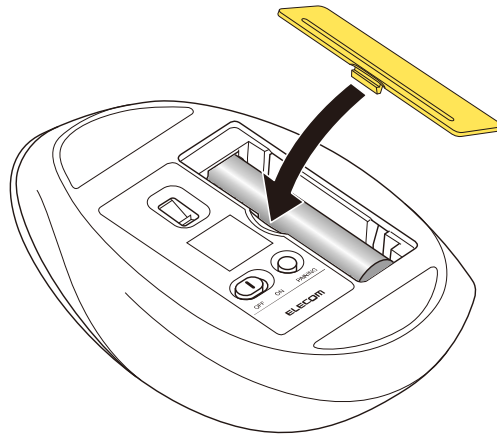

2. Pairing with a PC

- Pairing involves registering Bluetooth devices (in this case, this product and your device) with each other, and authorizing a connection between them.
- This section covers Chrome OS standard Bluetooth functions. Depending on your device, unique Bluetooth functions may be used. Please read the respective manuals for each function.
- Use your current mouse or the touchpad on your device to operate your device until pairing is complete.
- The following instructions are for Chrome OS (107.0.5304.110).

1) Click on the quick settings panel on the bottom right.

2) Click "Bluetooth".

If "Bluetooth" is off, turn it on.

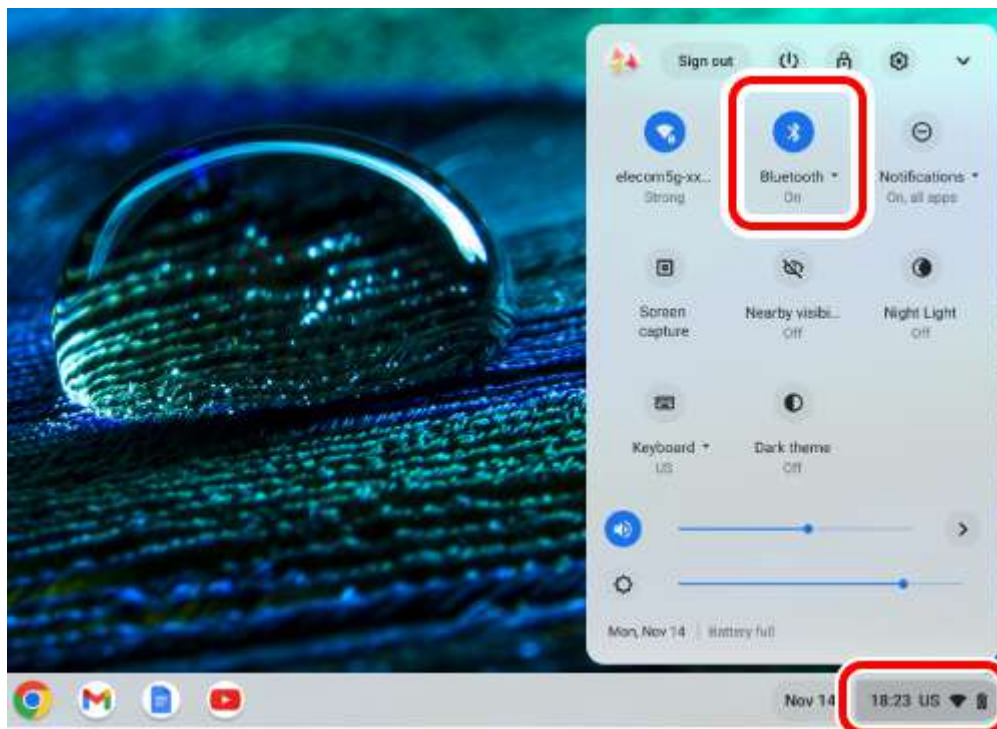

3) Press the button to switch between the connected devices.



* Please refer to **"Switch connected device"** to switch between connected devices.

• The selected connected Bluetooth device will be registered under your connected devices.

4) Click on “Pair new device”.

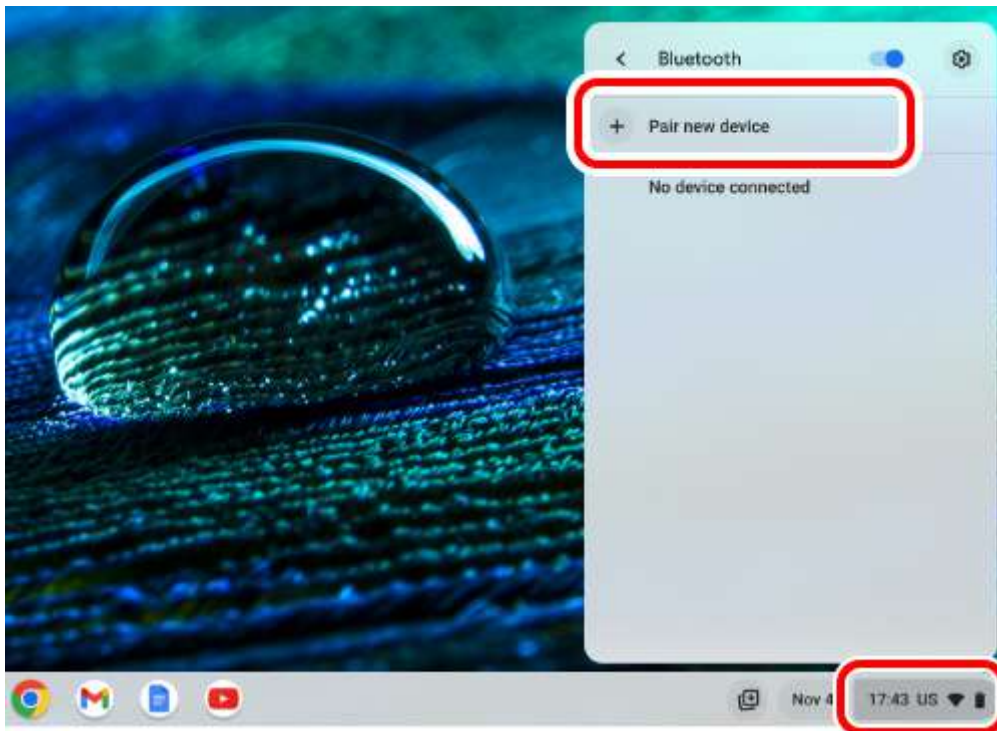

5) During the device search, hold down the pairing button on the underside for 3 seconds and then release.

Pairing mode will be activated and the LED will blink.

The LED will blink white when the connected device is "PC1" and green when it is "PC2".

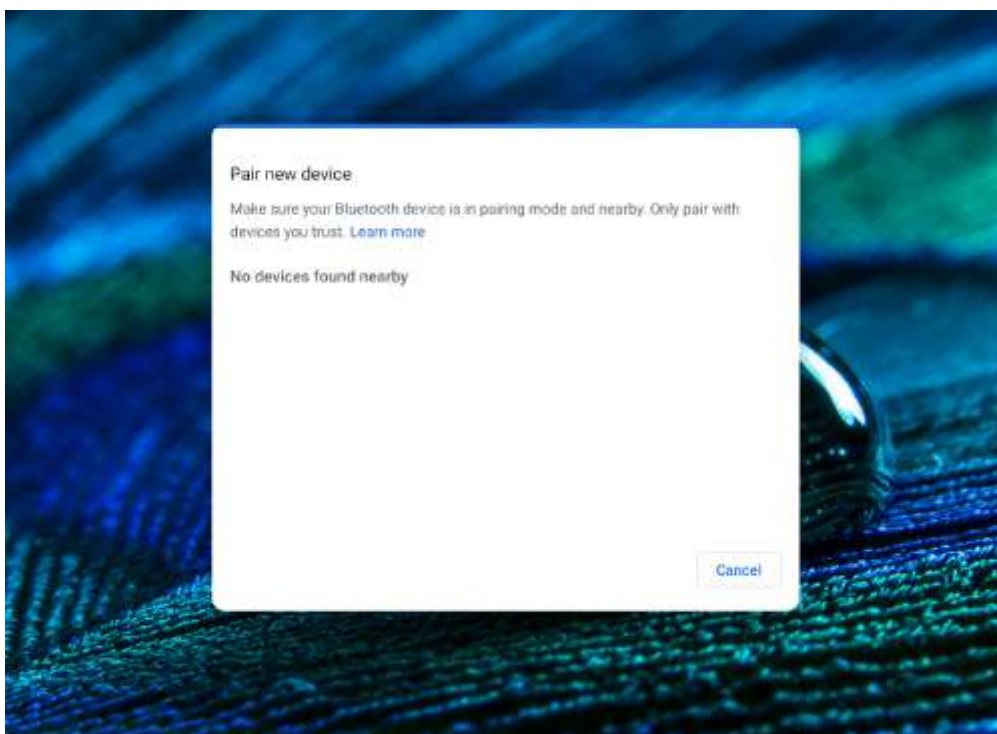

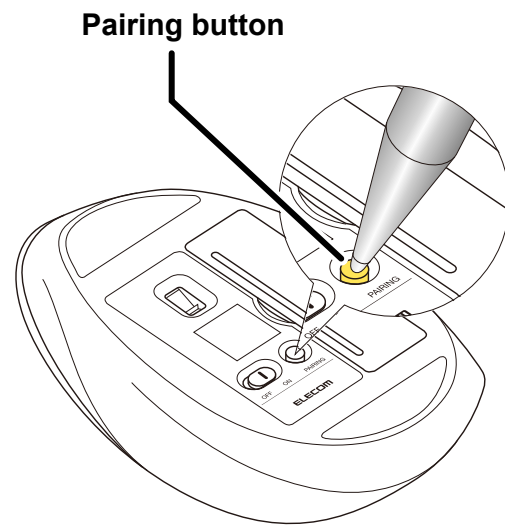

6) Click on "ELECOM OpticalMouse".

Pairing begins.

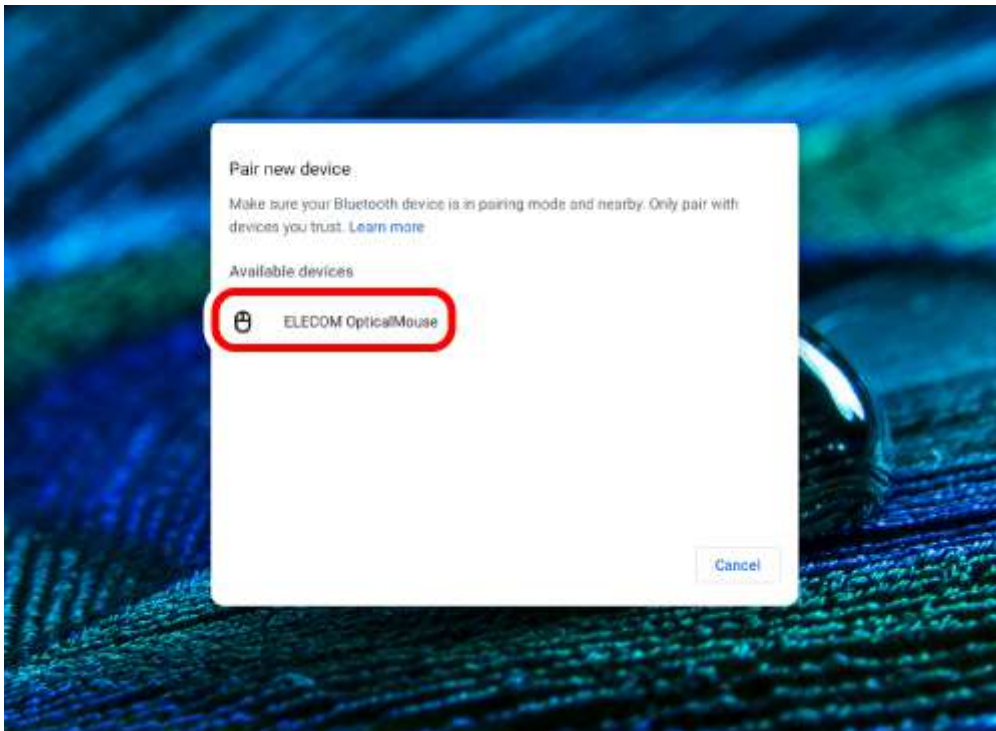

7) "ELECOM OpticalMouse connected" will be displayed at the bottom of the screen.

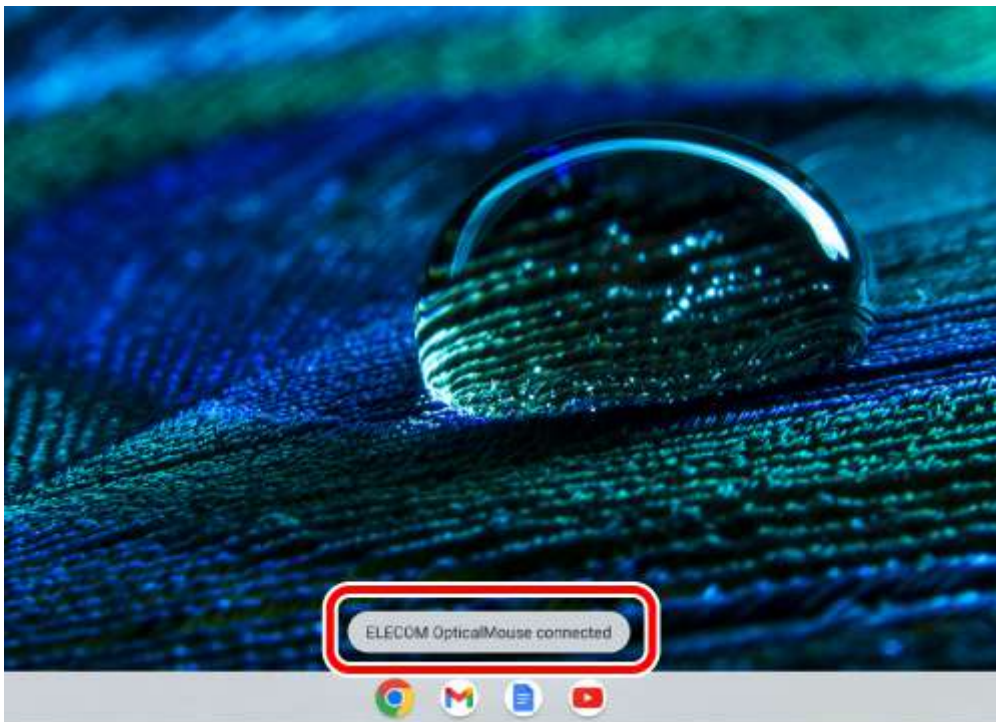

Click "Bluetooth" like in step 2. Pairing is complete when "ELECOM OpticalMouse" appears under "Previously connected".

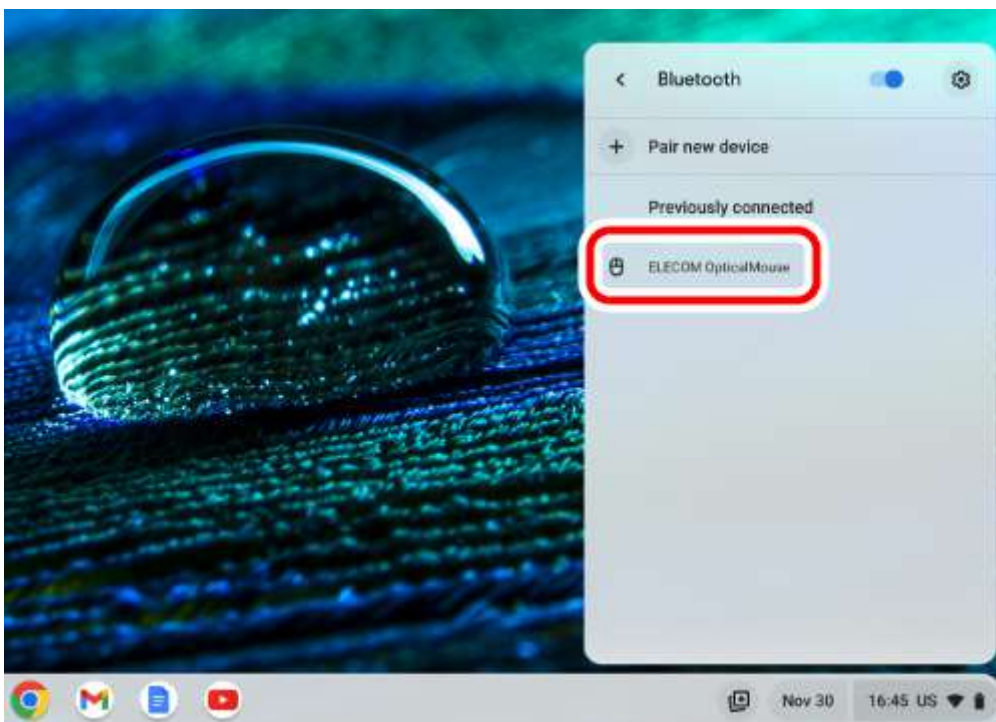

You can now use the mouse.

Change the mouse pointer speed

Adjust the mouse pointer movement speed on your PC if the mouse pointer moves too fast or too slow.

1) Click on the quick settings panel on the bottom right.

2) Click on "Settings".

The settings page will appear.

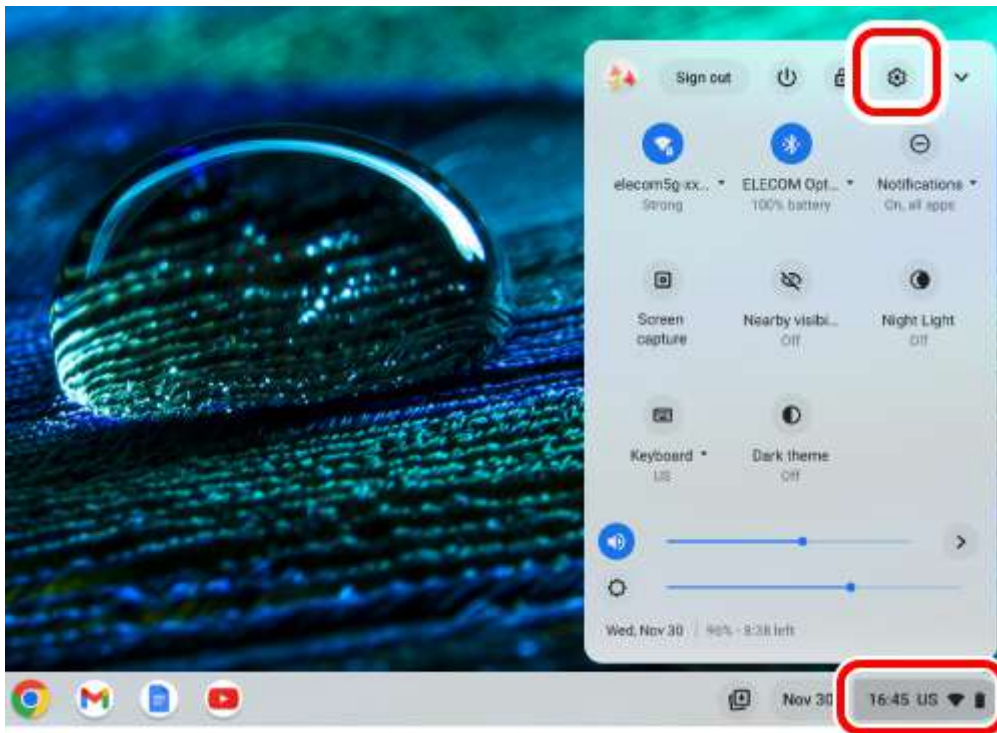

3) Click on “Mouse and touchpad” under “Device”.

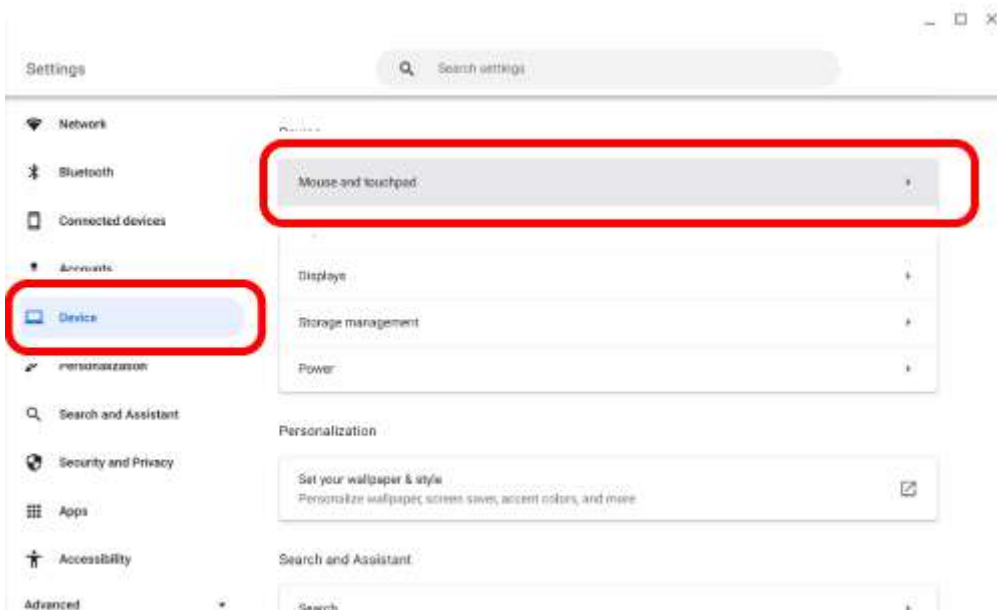

4) Adjust the “Mouse speed” slider to adjust the speed of the mouse pointer.

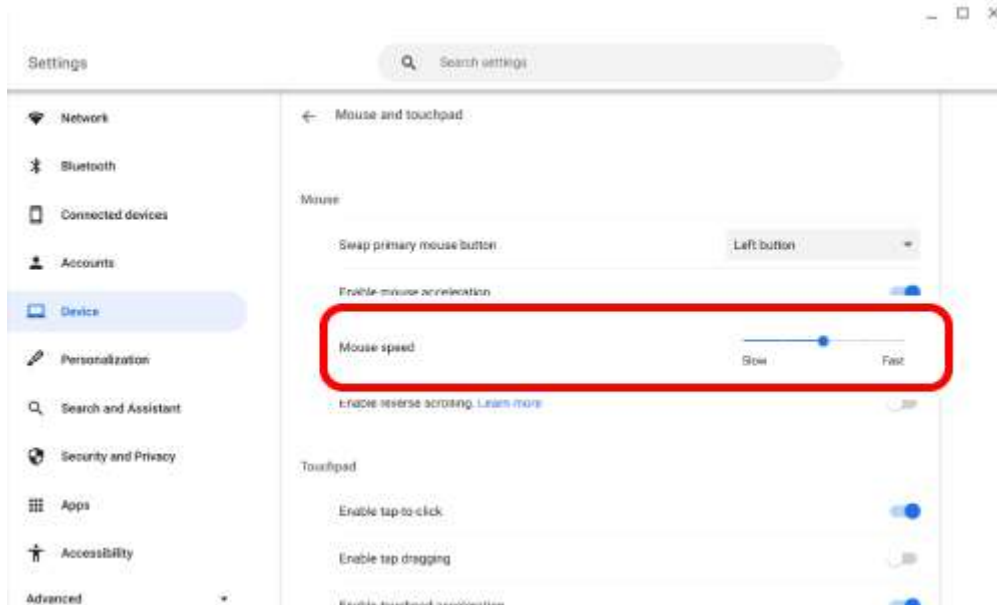

Install ELECOM Mouse Assistant



To use the function assignment function, fast scroll function and presentation mode with this product, the ELECOM Mouse Assistant must be installed.

“ELECOM Mouse Assistant” is a software that allows you to use the mouse more effectively.

Using ELECOM Mouse Assistant, users can set the functions they want to the unique buttons and use them to perform the operations they want.

■ Get ELECOM Mouse Assistant

Please visit our homepage below and download the latest version of the application.

> The download page is [here](#)

Product specifications



Compatible models	Windows OS, macOS, Chrome OS, Android, iOS and iPadOS-based devices that support Bluetooth® HOGP.
Supported OS	Windows 11, Windows 10, Windows 8.1, Android 13, macOS Ventura(13), Chrome OS, iOS 16, iPadOS 16 * Update for each new version of the OS or the installation of a service pack might be required. * Please see the table of supported devices for the latest information.
Conformity standards	Bluetooth 5.0 Class2 / profile: HOGP (HID Over GATT Profile)

* XXX will be determined when its fixed.

Resolution	2000CPI
Communication method	GFSK
Radio frequency	2.4GHz
Radio wave range	When used on magnetic surfaces such as metal desks: 3m, When used on non-magnetic surfaces such as wooden desks: 10m * These values were obtained in ELECOM's test environment and are not guaranteed.
Sensor Type	IR optical sensor
LED color	Blue
Buttons	5 * including wheel button
Number of wheels	1
Continuous operating time	Approximately xxx hours
Continuous standby time	Approximately xxx days
Projected battery lifespan	Approximately xxx days * assuming PC usage of 8 hours per day with 5% attributed to mouse operations
Power consumption	Any 1 of AA alkaline dry-cell battery, AA manganese dry-cell battery or AA nickel-metal hydride battery
Rated voltage	1.5V
Dimensions	M-XGS30BBS series: approximately W xx × D xxx × H xx mm (approximately W x.x × D x.x × H x.x inch) M-XGM30BBS series: approximately W xx × D xxx × H xx mm (approximately W x.x × D x.x × H x.x inch) M-XGL30BBS series: approximately W xx × D xxx × H xx mm (approximately W x.x × D x.x × H x.x inch) M-XGLL30BBS series: approximately W xx × D xxx × H xx mm (approximately W x.x × D x.x × H x.x inch)
Size category	M-XGS30BBS series: S size M-XGM30BBS series: M size

* XXX will be determined when its fixed.

	M-XGL30BBS series: L size M-XGLL30BBS series: LL size
Weight	M-XGS30BBS series: approximately xx g / approximately x.x oz M-XGM30BBS series: approximately xx g / approximately x.x oz M-XGL30BBS series: approximately xx g / approximately x.x oz M-XGLL30BBS series: approximately xx g / approximately x.x oz
Operating environment conditions	Temperature: 5°C to 40°C / humidity: ~90%RH (without condensation)
Storage environment conditions	Temperature -10°C to 60°C / humidity ~90%RH (without condensation)
Accessories	AA alkaline dry cell battery for confirming operability x 1

Compliance status



Model: M-XGx30BBS

▼ China / 中国

设备型号 M-XGM30BBS

CMIIT ID: XXXXXXXXXXX

设备型号 M-XGL30BBS

CMIIT ID: XXXXXXXXXXX

RoHS Compliance (产品中有毒有害物质或元素的名称及含量)

▼ EU

Model: M-XGLL30BBS



CE Declaration of Conformity

RoHS Compliance

Importer EU Contact (For CE matters only)

Around the World Trading, Ltd.

5th floor, Koenigsallee 2b, Dusseldorf, Nordrhein-Westfalen, 40212, Germany

WEEE Disposal and Recycling Information

This symbol means that waste of electrical and electronic equipment (WEEE) should not be disposed as general household waste. WEEE should be treated separately to prevent possible harm to the environment or human health. Consult your retailer or local municipal office for collection, return, recycle or reuse of WEEE.

▼ **Korea / 대한민국**



모델명: M-XGLL30BBS

인증번호: R-R-ELJ-M-XGLL30BBS

제작자 및 설치자는 해당 무선설비가 전파혼신 가능성이 있으므로 인명안전과 관련된 서비스는 할 수 없습니다.

▼ **Singapore**

Model: M-XGLL30BBS

Complies with
IMDA standards
DA106058.

Operating Frequencies: XXXX-XXXX MHz

Maximum field intensity / RF Output power: X.XX dBm / X.XX mW

▼ **Taiwan / 台灣**

型式: M-XGLL30BBS



BSMI RoHS statement (限用物質含有情況標示聲明書)



型號 M-XGLL30BBS: XXXXXXXXXXXXXXXX

型號 M-XGM30BBS: XXXXXXXXXXXXXXXX

取得審驗證明之低功率射頻器材，非經核准，公司、商號或使用者均不得擅自變更頻率、加大功率或變更原設計之特性及功能。低功率射頻器材之使用不得影響飛航安全及干擾合法通信；經發現有干擾現象時，應立即停用，並改善至無干擾時方得繼續使用。前述合法通信，指依電信管理法規定作業之無線電通信。低功率射頻器材須忍受合法通信或工業、科學及醫療用電波輻射性電機設備之干擾。

▼ UK



UK Declaration of Conformity

RoHS Compliance

Importer UK Contact (For UKCA matters only)

Around the World Trading, Ltd.

25 Clarendon Road Redhill, Surrey RH1 1QZ, United Kingdom

▼ US



M-XGLL30BBS

FCC ID: YWO-M-XGLL30BBS

This device complies with Part 15 of the FCC Rules. Operation is subject to the following two conditions: (1) this device may not cause harmful interference, and (2) this device must accept any interference received, including interference that may cause undesired operation.

NOTE; This equipment has been tested and found to comply with the limits for a Class B Digital Device, pursuant to part 15 of the FCC Rules. These limits are designed to provide reasonable protection against harmful interference in a residential installation. This equipment generates, uses and can radiated radio frequency energy and, if not installed and used in accordance with the instruction, may cause harmful interference to radio communication. However, there is no guarantee that interference will not occur in a particular installation. If this equipment does cause harmful interference to radio or television reception, which can be determined by tuning the equipment off and on, the user is encouraged to try to correct the interference by one or more of the following measures:

- Reorient or relocate the receiving antenna - Increase the separation between the equipment and receiver -
- Connect the equipment into an outlet on a circuit different from that to which the receiver is connected -
- Consult the dealer or an experienced radio/TV technician for help

NOTICE: The manufacture is not responsible for any radio or TV interference caused by unauthorized modification to this equipment. Such modifications could void the user's authority to operate the equipment.

In order to make improvements to this product, the design and specifications are subject to change without prior notice.

FCC Caution: To assure continued compliance, any changes or modifications not expressly approved by the party responsible for compliance could void the user's authority to operate this equipment. (Example - use only shielded interface cables when connecting to computer or peripheral devices).

FCC Radiation Exposure Statement

This equipment complies with FCC RF radiation exposure limits set forth for an uncontrolled environment. This equipment should be installed and operated with a minimum distance of 0.5 cm between the radiator and your body.

This transmitter must not be co-located or operating in conjunction with any other antenna or transmitter.

The antennas used for this transmitter must be installed to provide a separation distance of at least 0.5 cm from all persons and must not be co-located or operating in conjunction with any other antenna or transmitter.

Responsible party

ELECOM USA, Inc.

18575 Jamboree Road Suite 600, Irvine CA 92612 USA

elecomus.com

▼ Vietnam / Việt Nam

RoHS compliant list (Chứng Nhận Đạt Tiêu Chuẩn RoHS)