

# MASTERFORCE®

Radio with Bluetooth  
MODEL: OB20RDB

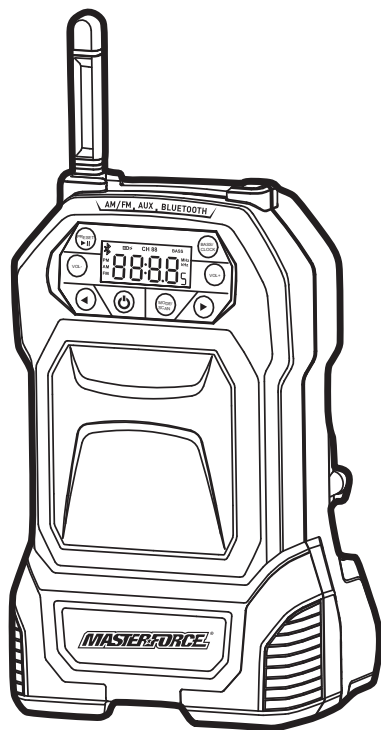

241-0446

## OPERATOR'S MANUAL

**CAUTION:** To Reduce the Risk of Injury, User Must Read and Understand Operator's Manual. Save These Instructions For Future Reference.

For questions / comments, technical assistance or repair parts –  
Please Call Toll Free: 1-866-917-4374. (M-F 8:30am-5:00pm Est.)

# TABLE OF CONTENTS

Safety Symbols.....	Page 2
Safety Instructions.....	Page 3
Overview/Specifications.....	Page 7
Assembly.....	Page 8
Operation.....	Page 9
Maintenance.....	Page 13
Troubleshooting.....	Page 13
Warranty.....	Page 14

# SAFETY SYMBOLS

Some of these following symbols may be used on this tool. Please study them and learn their meaning. Proper interpretation of these symbols will allow you to operate the tool better and more safely.

Symbol	Name	Designation / Explanation
V	Volts	Voltage
A	Amperes	Current
Hz	Hertz	Frequency (cycles per second)
W	Watts	Power
~	Alternating current	Type of current
≡	Direct current	Type or characteristic of current
lbs	Pounds	Weight
	Class II construction	Double insulated construction

 **WARNING:** To ensure safety and reliability, all repairs should be performed by a qualified service technician.

# SAFETY INSTRUCTIONS

The purpose of safety symbols is to attract your attention to possible dangers. The safety symbols and the explanations with them deserve your careful attention and understanding. The symbol warnings do not, by themselves, eliminate any danger. The instructions and warnings they give are no substitutes for proper accident prevention measures.

 **WARNING:** Be sure to read and understand all safety instructions in this manual, including all safety alert symbols such as “DANGER,” “WARNING,” and “CAUTION” before using this tool. Failure to following all instructions listed below may result in electric shock, fire, and/or serious personal injury.

---

## SYMBOL MEANING

 **SAFETY ALERT SYMBOL:** Indicates DANGER, WARNING, or CAUTION. May be used in conjunction with other symbols or pictographs.

 **DANGER:** Indicates an imminently hazardous situation, which, if not avoided, will result in death or serious injury.

 **WARNING:** Indicates a potentially hazardous situation, which, if not avoided, could result in death or serious injury.

 **CAUTION:** Indicates a potentially hazardous situation, which, if not avoided, could result in minor or moderate injury.

**NOTICE:** (Without Safety Alert Symbol) Indicates a situation that may result in property damage.

**SAVE THESE INSTRUCTIONS!**

# SAFETY INSTRUCTIONS



**WARNING:** Read all safety warnings and instructions!

Failure to follow the warnings and instructions may result in electric shock, fire and/or serious injury. Save all warnings and instructions for future reference.

The term power tool in the warnings refers to your mains-operated (corded) power tool or battery-operated (cordless) power tool.

## WORK AREA SAFETY

1. Keep the work area clean and well lit. Cluttered or dark areas invite accidents.
2. Do not operate power tools in explosive atmospheres, such as in the presence of flammable liquids, gases or dust. Power tools create sparks which may ignite the dust or fumes.

## ELECTRICAL SAFETY

1. A battery operated product with integral batteries or a separate battery pack must be recharged only with the specified charger for the battery. A charger that may be suitable for one type of battery may create a risk of fire when used with another battery.
2. Use battery operated product only with specifically designated battery pack. Use of any other batteries may create a risk of fire.
3. Use only with charger listed.

## PERSONAL SAFETY

1. Do not overreach. Keep proper footing and balance at all times. This enables better control of the power tool in unexpected situations.

2. Do not use on a ladder or unstable support. Stable footing on a solid surface enables better control of the product in unexpected situations.

## PRODUCT USE AND CARE

1. Do not use the power tool if the switch does not turn it on and off. Any power tool that cannot be controlled with the switch is dangerous and must be repaired.
2. Disconnect battery pack from product or place the switch in the locked or off position before making any adjustments, changing accessories, or storing the product. Such preventive safety measures reduce the risk of starting the product accidentally.
3. When battery pack is not in use, keep it away from other metal objects like: paper clips, coins, keys, nails, screws, or other small metal objects that can make a connection from one terminal to another. Shorting the battery terminals together may cause sparks, burns, or a fire.
4. Keep the radio and its handle dry, clean and free from oil and grease. Always use a clean cloth when cleaning. Never use brake fluids, gasoline, petroleum-based products, or any strong solvents to clean your radio. Following this rule will reduce the risk of loss of control and deterioration of the enclosure plastic.
5. Do not use this apparatus near water.
6. Clean only with dry cloth.
7. Do not block any ventilation openings. Install in accordance with the manufacturer's instructions.
8. Do not install near any heat sources such as radiators, heat registers, stoves, or other apparatus (including amplifiers) that produce heat.
9. Only use attachments/accessories specified by the manufacturer.

# SAFETY INSTRUCTIONS

## SERVICE

1. Have your power tool serviced by a qualified repair person using only identical replacement parts. This will ensure that the safety of the power tool is maintained.

## IMPORTANT SAFETY INSTRUCTIONS

1. Know your product. Read operator's manual carefully. Learn its applications and limitations, as well as the specific potential hazards related to this product. Following this rule will reduce the risk of electric shock, fire, or serious injury.

2. Battery products do not have to be plugged into an electrical outlet; therefore, they are always in operating condition. Be aware of possible hazards when not using your battery product or when changing accessories. Following this rule will reduce the risk of electric shock, fire, or serious personal injury.

3. Do not place battery products or their batteries near fire or heat. This will reduce the risk of explosion and possibly injury.

4. Do not crush, drop or damage battery pack. Do not use a battery pack or charger that has been dropped or received a sharp blow. A damaged battery is subject to explosion. Properly dispose of a dropped or damaged battery immediately.

5. Batteries can explode in the presence of a source of ignition, such as a pilot light. To reduce the risk of serious personal injury, never use any cordless product in the presence of open flame. An exploded battery can propel debris and chemicals. If exposed, flush with water immediately.

6. Do not charge battery product in a damp or wet location. Following this rule will reduce the risk of electric shock.

7. Under extreme usage or temperature conditions, battery leakage may occur. If liquid comes in contact with your skin, wash immediately with soap and water, then neutralize with lemon juice or vinegar. If liquid gets into your eyes, flush them with clean water for at least 10 minutes, then seek immediate medical attention. Following this rule will reduce the risk of serious personal injury.

8. To reduce the risk of personal injury and electric shock, the product should not be played with or placed where small children can reach it.

9. To reduce the risk of electric shock, do not expose to water or rain.

10. Do not use the radio to listen to music or other audio programs while operating machinery. Doing so may cause distractions that could result in serious personal injury.

11. This radio is capable of producing sound levels that can be dangerous to long-term hearing. Listening to music at high volume for any period of time may cause noise-induced hearing loss. The higher the volume, the less time required before your hearing may be affected.

12. Save these instructions. Refer to them frequently and use them to instruct others who may use this tool. If you loan someone this tool, loan them these instructions also to prevent misuse of the product and possible injury.

# SAFETY INSTRUCTIONS

## FCC STATEMENT

1. This device complies with Part 15 of the FCC Rules. Operation is subject to the following two conditions:

- (1) This device may not cause harmful interference.
- (2) This device must accept any interference received, including interference that may cause undesired operation.

2. Changes or modifications not expressly approved by the party responsible for compliance could void the user's authority to operate the equipment.

**NOTE: This equipment has been tested and found to comply with the limits for a Class B digital device, pursuant to Part 15 of the FCC Rules. These limits are designed to provide reasonable protection against harmful interference in a residential installation.**

This equipment generates uses and can radiate radio frequency energy and, if not installed and used in accordance with the instructions, may cause harmful interference to radio communications. However, there is no guarantee that interference will not occur in a particular installation. If this equipment does cause harmful interference to radio or television reception, which can be determined by turning the equipment off and on, the user is encouraged to try to correct the interference by one or more of the following measures:

- Reorient or relocate the receiving antenna.
- Increase the separation between the equipment and receiver.
- Connect the equipment into an outlet on a circuit different from that to which the receiver is connected.
- Consult the dealer or an experienced radio/TV technician for help.

RF warning statement:

The device has been evaluated to meet general RF exposure requirement. The device can be used in portable exposure condition without restriction.

# OVERVIEW

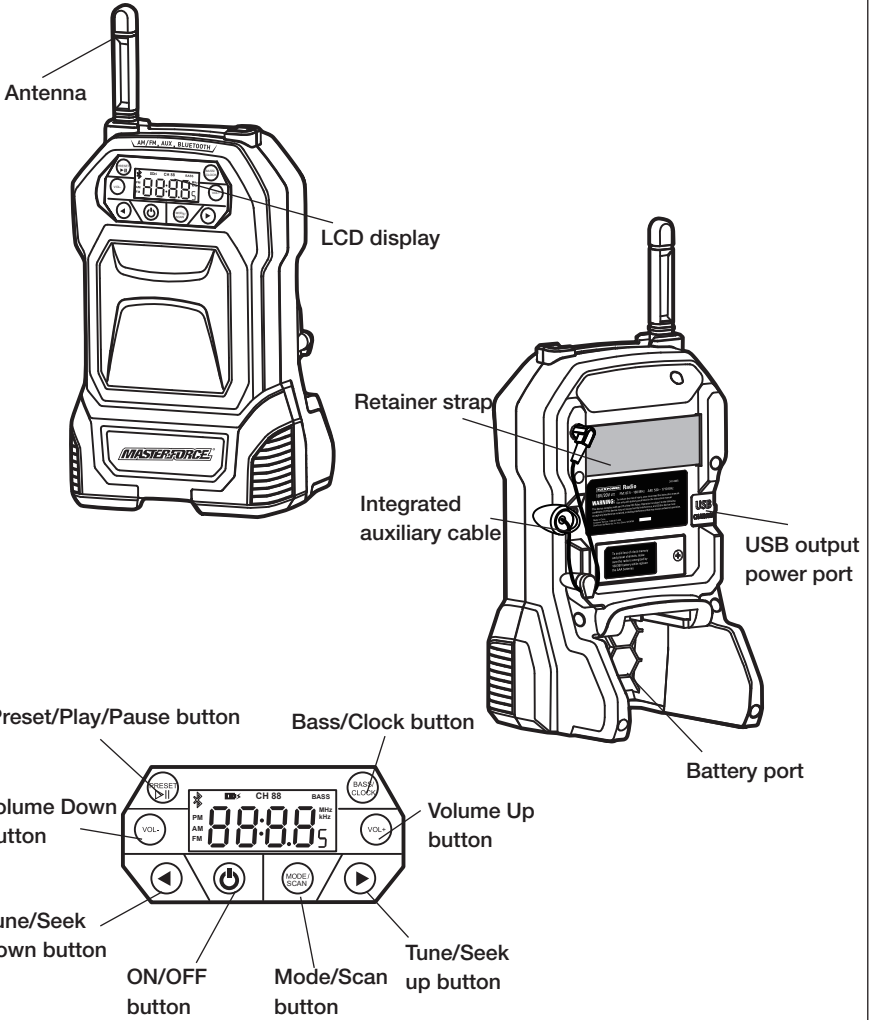



# SPECIFICATIONS

AM Tuner	530-1710 KHz
FM Tuner	87.5-108 MHz
Auxiliary Cable	3.5 mm plug
USB Output Charge Port	5V DC, 1 A (max)
Weight (without battery)	1 lbs. 8 oz.
Compatible Battery Packs	252-8027
	252-8029
	252-8030
	252-8031
	252-8034
	252-8035
Battery Chargers	252-8025, 252-8026, 252-8036, 252-8037, 252-8044

# ASSEMBLY

## CONTENTS

 **WARNING:** If any part is broken or missing, **DO NOT** attempt to attach the battery pack, or operate the tool until the broken or missing part is replaced. Failure to do so could result in possible serious injury.

Radio and Operator's manual

## UNPACKING

 **WARNING:** Do not attempt to modify this tool or create accessories not recommended for use with this tool. Any such alteration or modification is misuse and could result in a hazardous condition leading to possible serious injury.

1. Carefully remove the radio and any accessories from the carton. Make sure that all items listed in the packing list are included.
2. Inspect the radio carefully to make sure that no breakage or damage occurred during shipping.
3. Do not discard the packing material until you have carefully inspected and satisfactorily operated the radio.

# OPERATION

## TO INSTALL/REMOVE AAA BATTERIES

It is advisable to write down stored frequencies before replacing the AAA batteries if, at the time of AAA battery replacement, the 18/20V battery pack is removed or has no charge. The radio will lose all settings previously stored in memory when replacing the AAA batteries in this situation, and they will require reprogramming.

Always use new alkaline batteries for replacement.

1. Use a Philips screwdriver to loosen the screw from the battery cover. Remove the screw.
2. Remove the battery cover.
3. Install two new AAA batteries according to polarity indicators inside the battery compartment.
4. Replace the battery cover and secure it with the screw.

**NOTICE:** Do not mix old and new batteries.

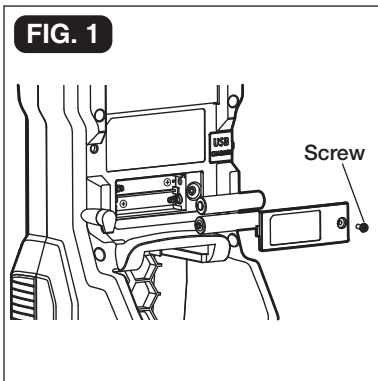

## TO INSTALL/REMOVE 18/20V BATTERY PACK

**To install:**

1. Place the battery pack in the radio, aligning the raised rib on the battery pack with the groove in the radio's battery port.
2. Make sure that the latches on each side of the battery pack snap into place and the battery pack is secured to the radio.

**To remove:**

1. Depress the battery-release button, located on the front of the battery pack to release the battery pack.
2. Pull the battery pack and remove it from the radio.

## LCD DISPLAY

The LCD display on the front of the radio illuminates when the radio is turned on. It will display the radio mode and frequency/channel setting. The LCD will be dark if there is no operation within 10 seconds.

## TURNING THE RADIO ON/OFF

Press and hold the  button for three seconds to turn the radio on or off.

**NOTICE:** If AAA batteries have been installed, the time will be displayed when the radio is off, even if the 18/20V battery pack is removed.

# OPERATION

## ADJUSTING THE VOLUME

When the radio is turned ON, it will initially return to the last volume setting used.

**NOTICE:** If both 18/20V battery pack and AAA batteries are removed from the radio or have no charge, the radio will return to the default volume setting.

To increase the volume: Press the **VOL+** button.

To decrease the volume: Press the **VOL-** button.

To change volume quickly, hold the **VOL+** or **VOL-** button.

## EQ ADJUSTMENT

To increase the bass sound, press the **BASS/CLOCK** button and quickly release it. To go back to the balance setting press the **BASS/CLOCK** button and quickly release it again.

## MODE SELECTION

To switch modes, press the **MODE/SCAN** button and quickly release it. The selected mode will be shown in the digital display. There are four modes:

- FM mode
- AM mode
- AUX mode
- BLUETOOTH mode

**NOTICE:** When turned on, the radio will return to the last mode that was used, unless both AAA batteries and 18/20V battery pack are removed or lose charge.

## CHANGING CHANNELS

The ◀▶ buttons are used to manually tune to the desired radio frequency. The selected frequency is displayed on the digital display.

**To use tune feature:**

1. Press the ◀ or ▶ button and quickly release to manually scroll through radio channels one frequency at a time.

**To use seek feature:**

1. Press and hold the ◀ button for three seconds to tune to the next lowest frequency with clear reception.
2. Press and hold the ▶ button for three seconds to tune to the next highest frequency with clear reception.

**To use scan feature:**

1. Press and hold the **MODE/SCAN** button for three seconds to seek through the band.
2. The scanning will pause when each channel is found and all channels will be saved automatically in the memory.
3. Press the ◀ or ▶ button to stop scanning

**To use the FM antenna:**



Raise or lower radio antenna until the radio channel can be heard clearly.

# OPERATION

## STORING A PRESET IN MEMORY

The memory feature saves up to 40 frequencies as presets in the radio's memory. You can save 20 frequencies in FM mode and 20 in AM mode.

To store a frequency in memory:

1. Tune to the frequency you want to save.
2. Press and hold the  button. A memory location number will blink on and off.
3. Press the ◀ or ▶ button to select a memory location.
4. Press the  button and quickly release it to store the frequency in the selected memory location.

To recall a preset frequency:

1. Press the  button and quickly release it to cycle through the stored frequencies.

## SETTING THE CLOCK

The time is always displayed when the radio is turned off and in AUX mode.

**NOTICE:** If both AAA batteries and 18/20V battery pack are removed or lose their charge, the clock settings will be lost. Settings are not affected by the removal of only the 18/20V battery pack.

To set the clock:

1. Press and hold the BASS/CLOCK button. The number representing the hours will blink on and off.

**NOTICE:** If you do not press a button within 10 seconds, the clock programming feature will automatically return to the previous setting.

2. Press the ◀ or ▶ button to set the hour. For AM/PM settings, scroll through the first 12 numbers until AM/PM is displayed.

3. Press the BASS/CLOCK button quickly. The number representing the minutes will blink on and off.
4. Press the ◀ or ▶ button to set the minutes.
5. Press the BASS/CLOCK button again to save.

## USING MEDIA PLAYER

1. Select AUX mode. Refer to MODE SELECTION.
2. The RETAINER STRAP may be used to secure the media player into position.
3. Connect the integrated auxiliary cable to the media player .
4. The media player must be ON and in PLAY mode for sound to be heard through the speaker.
5. All media player controls can be used normally while connected to the radio.

**NOTICE:** Volume for any device connected through the auxiliary connector can be adjusted using the volume control for that device or with the VOL+ or VOL- buttons on the radio.

- Turning the radio OFF will NOT turn the media player OFF.

**NOTICE:** The integrated auxiliary cable DOES NOT provide a charging function for auxiliary devices.

## CHARGING/POWERING A USB DEVICE





The USB Output POWER PORT charges/powers most devices that can accept power through a USB connection.

# OPERATION

## PAIRING A BLUETOOTH ENABLED DEVICE

1. Select Bluetooth mode; refer to **MODE SELECTION**. The logo “”, representing Bluetooth will, blink on and off.
2. Turn on the Bluetooth function of your mobile phone or other Bluetooth-enabled device, search the “MASTERFORCE RADIO” device and connect to it.

**NOTICE:** Usually you needn't to input password for most Bluetooth devices. If a password is required, use “0000” as the password.

3. “” will stop flashing to indicate that pairing was successful.
4. After successfully pairing, you can begin playing music from your Bluetooth device wirelessly through the radio.
5. Press the ◀ and ▶ buttons to choose the previous or next track.
6. To pause or begin the play, press the **PRESET**  button quickly.
7. To disconnect the BLUETOOTH-enabled device, press and hold the **PRESET**  button. “” will blink on and off to indicate that the devices are no longer paired.

## MAINTENANCE

**⚠ WARNING:** To avoid serious personal injury, always remove the battery pack from the radio when cleaning or performing any maintenance. Contact a qualified service technician for all repairs.

**⚠ WARNING:** When servicing, use only identical replacement parts. Use of any other parts may create a hazard or cause product damage. For more information, call the toll-free helpline, at 1-866-917-4374.

**⚠ WARNING:** Avoid using solvents when cleaning plastic parts. Most plastics are susceptible to damage from various types of commercial solvents and may be damaged by their use. Use a clean cloth to remove dirt, dust, oil, grease, etc.

**⚠ WARNING:** Using compressed air may be the most effective cleaning method. Always wear safety goggles when cleaning tools with compressed air.

## TROUBLESHOOTING

PROBLEM	CAUSE	SOLUTION
The radio does not work.	The 18/20V battery pack is depleted.	Charge the battery pack.
The radio lost clock memory and preset channels after the 18/20V battery pack is removed.	The AAA size batteries are depleted.	Replace the AAA batteries.



## **CORDLESS JOBSITE RADIO WARRANTY**

### **90-DAY MONEY BACK GUARANTEE:**

This MASTERFORCE® brand power tool carries our 90-DAY Money Back Guarantee. If you are not completely satisfied with your MASTERFORCE® brand power tool for any reason within ninety (90) days from the date of purchase, return the tool with your original receipt to any MENARDS® retail store, and we will provide you a refund – no questions asked.

### **3-YEAR LIMITED WARRANTY:**

This MASTERFORCE® brand power tool carries our famous No Hassle 3-Year Limited Warranty to the original purchaser. If, during normal use, this MASTERFORCE® power tool breaks or fails due to a defect in material or workmanship within three (3) years from the date of original purchase, simply bring this tool with the original sales receipt back to your nearest MENARDS® retail store. At its discretion, MASTERFORCE® agrees to have the tool or any defective part(s) repaired or replaced with the same or similar MASTERFORCE® product or part free of charge, within the stated warranty period, when returned by the original purchaser with original sales receipt. Notwithstanding the foregoing, this limited warranty does not cover any damage that has resulted from abuse or misuse of the Merchandise. This warranty: (1) excludes expendable parts including but not limited to blades, brushes, belts, bits, light bulbs, and/or batteries; (2) shall be void if this tool is used for commercial and/or rental purposes; and (3) does not cover any losses, injuries to persons/property or costs. This warranty does give you specific legal rights and you may have other rights, which vary from state to state. Be careful, tools are dangerous if improperly used or maintained. Seller's employees are not qualified to advise you on the use of this Merchandise. Any oral representation(s) made will not be binding on seller or its employees. The rights under this limited warranty are to the original purchaser of the Merchandise and may not be transferred to any subsequent owner. This limited warranty is in lieu of all warranties, expressed or implied including warranties or merchantability and fitness for a particular purpose. Seller shall not be liable for any special, incidental, or consequential damages. The sole exclusive remedy against the seller will be for the replacement of any defects as provided herein, as long as the seller is willing or able to replace this product or is willing to refund the purchase price as provided above. For insurance purposes, seller is not allowed to demonstrate any of these power tools for you.

For questions / comments, technical assistance or repair parts – Please Call Toll Free at: 1-866-917-4374. (M-F 8:30am-5:00pm Est.)

**SAVE YOUR RECEIPTS  
THIS WARRANTY IS VOID WITHOUT THEM**

**MASTER★FORCE®**

**MENARDS®**