

Prüfbericht-Nr.: <i>Test Report No.:</i>	50299306 001	Auftrags-Nr.: <i>Order No.:</i>	238109710	Seite 1 von 50 <i>Page 1 of 50</i>	
Kunden-Referenz-Nr.: <i>Client Reference No.:</i>	N/A	Auftragsdatum: <i>Order date:</i>	09-Sep-2019		
Auftraggeber: <i>Client:</i>	Pass & Seymour, Inc. d/b/a Legrand 301 Fulling Mill Road, Suite G, Middletown, PA 17057				
Prüfgegenstand: <i>Test item:</i>	Led Light strip				
Bezeichnung / Typ-Nr.: <i>Identification / Type No.:</i>	HKT1				
Auftrags-Inhalt: <i>Order content:</i>	FCC Part 15C / ISED RSS-247 Test report (Wi-Fi 2.4GHz)				
Prüfgrundlage: <i>Test specification:</i>	FCC 47CFR Part 15: Subpart C Section 15.247 ISED RSS-247 (02-2017)				
Wareneingangsdatum: <i>Date of receipt:</i>	3-Oct-2019				
Prüfmuster-Nr.: <i>Test sample No.:</i>	A000677355-004 A000677355-005				
Prüfzeitraum: <i>Testing period:</i>	04-Oct-2019 – 23-Oct-2019				
Ort der Prüfung: <i>Place of testing:</i>	EMC/RF Laboratory Taipei				
Prüflaboratorium: <i>Testing laboratory:</i>	TUV Rheinland Taiwan Ltd.				
Prüfergebnis*: <i>Test result*:</i>	Pass				
geprüft von / tested by:		kontrolliert von / reviewed by:			
2019-11-04	Mars Y.J. Lin /Project Engineer	2019-11-04	Arvin Ho /Vice General Manager		
Datum <i>Date</i>	Name / Stellung <i>Name / Position</i>	Unterschrift <i>Signature</i>	Datum <i>Date</i>	Name / Stellung <i>Name / Position</i>	Unterschrift <i>Signature</i>
Sonstiges / Other:					
The test data was copied from the original test report(Report Number:50296855-001) based on the information provided by the manufacturer(DEXATEK TECHNOLOGY LTD.), all the listed models are electrically identical as the device be tested and recorded within the original test report but just with different brand name and model series for marketing purpose.					
Zustand des Prüfgegenstandes bei Anlieferung: <i>Condition of the test item at delivery:</i>		Prüfmuster vollständig und unbeschädigt <i>Test item complete and undamaged</i>			
* Legende:	1 = sehr gut P(ass) = entspricht o.g. Prüfgrundlage(n)	2 = gut F(ail) = entspricht nicht o.g. Prüfgrundlage(n)	3 = befriedigend N/A = nicht anwendbar	4 = ausreichend N/T = nicht getestet	5 = mangelhaft
Legend:	1 = very good P(ass) = passed a.m. test specification(s)	2 = good F(ail) = failed a.m. test specification(s)	3 = satisfactory N/A = not applicable	4 = sufficient N/T = not tested	5 = poor
Dieser Prüfbericht bezieht sich nur auf das o.g. Prüfmuster und darf ohne Genehmigung der Prüfstelle nicht auszugsweise vervielfältigt werden. Dieser Bericht berechtigt nicht zur Verwendung eines Prüfzeichens. <i>This test report only relates to the a. m. test sample. Without permission of the test center this test report is not permitted to be duplicated in extracts. This test report does not entitle to carry any test mark.</i>					

TEST SUMMARY

5.1.1 ANTENNA REQUIREMENT

RESULT: *Passed*

5.1.2 PEAK OUTPUT POWER

RESULT: *Passed*

5.1.3 6dB BANDWIDTH AND 99% BANDWIDTH

RESULT: *Passed*

5.1.4 POWER DENSITY

RESULT: *Passed*

5.1.5 CONDUCTED SPURIOUS EMISSIONS AND FREQUENCY BAND EDGE MEASURED IN 100KHZ BANDWIDTH

RESULT: *Passed*

5.1.6 SPURIOUS EMISSION

RESULT: *Passed*

5.1.7 MAINS CONDUCTED EMISSIONS

RESULT: *Passed*

6.1.1 ELECTROMAGNETIC FIELDS

RESULT: *Passed*

Contents

1.	GENERAL REMARKS	5
1.1	COMPLEMENTARY MATERIALS.....	5
2.	TEST SITES	6
2.1	TEST LABORATORY	6
2.2	TEST FACILITY.....	6
2.3	LIST OF TEST AND MEASUREMENT INSTRUMENTS.....	7
2.4	TRACEABILITY	8
2.5	CALIBRATION	8
2.6	MEASUREMENT UNCERTAINTY	8
3.	GENERAL PRODUCT INFORMATION.....	9
3.1	PRODUCT FUNCTION AND INTENDED USE	9
3.2	SYSTEM DETAILS AND RATINGS.....	9
3.3	INDEPENDENT OPERATION MODES.....	10
3.4	NOISE GENERATING AND NOISE SUPPRESSING PARTS	10
3.5	SUBMITTED DOCUMENTS.....	10
4.	TEST SET-UP AND OPERATION MODES.....	11
4.1	PRINCIPLE OF CONFIGURATION SELECTION	11
4.2	TEST OPERATION AND TEST SOFTWARE.....	12
4.3	AUXILIARY EQUIPMENT	13
4.4	COUNTERMEASURES TO ACHIEVE EMC COMPLIANCE.....	13
4.5	TEST SETUP DIAGRAM	13
5.	TEST RESULTS	15
5.1	TRANSMITTER REQUIREMENT & TEST SUITES.....	15
5.1.1	<i>Antenna Requirement</i>	<i>15</i>
5.1.2	<i>Peak Output Power</i>	<i>16</i>
5.1.3	<i>6dB Bandwidth and 99% Bandwidth.....</i>	<i>17</i>
5.1.4	<i>Power Density</i>	<i>26</i>
5.1.5	<i>Conducted spurious emissions and Frequency Band Edge measured in 100kHz Bandwidth.....</i>	<i>33</i>
5.1.6	<i>Spurious Emission</i>	<i>43</i>
5.1.7	<i>Mains Conducted Emissions.....</i>	<i>44</i>
6.	SAFETY HUMAN EXPOSURE	45
6.1	RADIO FREQUENCY EXPOSURE COMPLIANCE	45
6.1.1	<i>Electromagnetic Fields.....</i>	<i>45</i>

Prüfbericht - Nr.: 50299306 001
Test Report No.

Seite 4 von 50
Page 4 of 50

PHOTOGRAPHS OF THE TEST SET-UP	46
7. LIST OF TABLES	50
8. LIST OF PHOTOGRAPHS.....	50

1. General Remarks

1.1 Complementary Materials

The following attachments are integral parts of this test report:

Appendix P: Photo Documentation

(File Name: 50299306 001 APPENDIXP)

Appendix D: Test Result of Radiated Emissions

(File Name: 50299306 001 APPENDIXD)

Test Specifications

The following standards were applied (in bold: product standards, otherwise: basic standards).

Table 1: Applied Standard and Test Levels

Radio
FCC 47CFR Part 15: Subpart C Section 15.247 FCC 47CFR Part 2: Subpart J Section 2.1091 ISED RSS-247 Issue 2 (Feb 2017) ISED RSS-102 Issue 5 (Mar 2015) ISED RSS-Gen Issue 5 (Mar 2019) ANSI C63.10:2013 KDB558074 D01 DTS Meas Guidance v03r05 KDB447498 D01 General RF Exposure Guidance v06

2. Test Sites

2.1 Test Laboratory

TUV Rheinland Taiwan Ltd.
Taipei Testing Laboratories

11F. No.758, Sec. 4, Bade Rd., Songshan Dist.
Taipei City 105
Taiwan (R.O.C.)

2.2 Test Facility

TUV Rheinland Taiwan Ltd.

11F. No.758, Sec. 4, Bade Rd., Songshan Dist.
Taipei City 105
Taiwan (R.O.C.)

FCC Registration No.: 180491
IC Canada Registration No.: 9465A
TAF Accredited NCC Test Lab. No.:3567
TAF ISO17025 Certification effective period: 6th-May-2019 to 05th-May-2022



Testing Laboratory
3567

2.3 List of Test and Measurement Instruments

Table 2: List of Test and Measurement Equipment

Equipment	Manufacturer	Model No.	Serial No.	Cal. Date	Cal. Due Date
EMI Test Receiver	R&S	ESR7	102109	2019/4/17	2020/4/16
Spectrum Analyzer	R&S	FSV40	101509	2019/2/4	2020/2/4
Pre-Amplifier	Agilent	8447D	2727A05146	2019/2/22	2020/2/22
Pre-Amplifier	EMCI	EMC051845SE	980635	2019/2/25	2020/2/25
Pre-Amplifier	EMCI	EMC184045SE	980656	2019/2/23	2020/2/23
Bilog Antenna	SCHWARZBECK	VULB-9168	00950	2019/1/14	2020/1/14
Horn Antenna	ETS-Lindgren	3117	00218929	2018/12/27	2019/12/27
Horn Antenna	SCHWARZBECK	BBHA 9170	00890	2019/4/12	2020/4/11
Loop Antenna	Schwarzbeck	FMZB 1513	1513-076	2019/07/11	2020/07/11
Test Software	Audix	e3	Ver. 9	N/A	N/A
Test Cable	HUBER+SUHNE R	SUCOFLEX 104EA	800057/4EA	2019/4/11	2020/4/10
Test Cable	HUBER+SUHNE R	SUCOFLEX 104	802244/4	2019/4/11	2020/4/10
Test Cable	HUBER+SUHNE R	SUCOFLEX 104	MY37203/4	2019/4/11	2020/4/10
Test Cable	HUBER+SUHNE R	SUCOFLEX 102EA	800897/2EA	2019/4/11	2020/4/10
Test Cable	HUBER+SUHNE R	SUCOFLEX 102EA	800902/2EA	2019/4/11	2020/4/10
Test Cable	HUBER+SUHNE R	SUCOFLEX 102EA	801026/2EA	2019/4/11	2020/4/10
EMI Test Receiver	Rohde & Schwarz	ESCI 7	100797	2019/01/16	2020/01/16
Two-Line V- Network (for EUT)	Rohde & Schwarz	ENV216	101243	2019/06/23	2020/06/23
Two-Line V- Network	Rohde & Schwarz	ENV216	101262	2019/07/16	2020/07/16
Telecom ISN 4 Line	Fischer Custom Communications	FFCC-TLISN- T4-02-09	101168	2019/01/02	2020/01/02
Impedance Stabilization Network	TESEQ	ISN T800	51949	2019/02/20	2020/02/20
Pulse Limiter	Rohde & Schwarz	ESH3-Z2	0357.8810.54- 102102-HN	2019/07/25	2020/07/25
Spectrum Analyzer	Agilent	N9010A	MY53470241	2019/06/17	2020/06/17
Power Meter	Anritu	ML2495A	1901008	2019/04/29	2020/04/29

2.4 Traceability

All measurement equipment calibrations are traceable to NML(Taiwan)/NIST(USA) or where calibration is performed outside Taiwan, to equivalent nationally recognized standards organizations.

2.5 Calibration

Equipment requiring calibration is calibrated periodically by the manufacturer or according to manufacturer's specifications. Additionally all equipment is verified for proper performance on a regular basis using in house standards or comparisons.

2.6 Measurement Uncertainty

The estimated combined standard uncertainty for radiated emissions and conducted emissions measurements are ± 3 dB.

Table 3: Emission Measurement Uncertainty

Parameter	Uncertainty
RF power, conducted	± 1.5 dB
Adjacent channel power	± 3 dB
Radiated emission of transmitter, valid up to 26 GHz	± 6 dB
Radiated emission of receiver, valid up to 26 GHz	± 6 dB
Temperature	± 2 °C
Humidity	± 10 %

3. General Product Information

3.1 Product Function and Intended Use

The EUT is a Led Light strip. It contains a Wi-Fi 2.4GHz compatible module enabling the user to communicate data through a Wireless interface.
For details refer to the User Guide, Data Sheet and Circuit Diagram.

3.2 System Details and Ratings

Table 4: Basic Information of EUT

Item	EUT information
Kind of Equipment	Led Light strip
Type Designation	HKT1
FCC ID	YV8-SA7199
Canada ID	9922A-SA7199
Canada HVIN	HKT1

Table 5: Technical Specification of EUT

Technical Specification	Value
Operating Frequencies	2412 MHz ~ 2462 MHz
Channel Spacing	5 MHz
Channel number	802.11b/g/n20 : 11 (2412 MHz ~ 2462 MHz)
Operation Voltage	Power Adapter: Input:100-240v 1.5A ; Output: 20V 3.25A
Modulation	802.11b: DSSS ; 802.11g/n20: OFDM
Antenna gain	2.01dBi

3.3 Independent Operation Modes

Basic operation modes are:

- A. Transmitting
 - 1. Low channel
 - 2. Middle channel
 - 3. High channel
- B. Receiving
- C. Standby
- D. Off

3.4 Noise Generating and Noise Suppressing Parts

Refer to the Circuit Diagram.

3.5 Submitted Documents

- Bill of Material
- PCB Layout
- Photo Document
- Technical Description
- Circuit Diagram
- Instruction Manual
- Rating Label

4. Test Set-up and Operation Modes

4.1 Principle of Configuration Selection

The equipment under test (EUT) was configured to measure its maximum power level. The test modes were adapted accordingly in reference to the instructions for use.

During testing, Channel and Power Controlling Software provided by the customer was used to control the operating channel as well as the output power level. The RF output power selection is for the setting of RF output power expected by the customer and is going to be fixed on the firmware of the final end product.

Table 6: Table for Parameters of Test Software Setting

Mode	Channel Frequency		
	2412 MHz	2437 MHz	2462 MHz
802.11b	47	51	53
802.11g	54	54	54
802.11n20	52	52	52

4.2 Test Operation and Test Software

Setup for testing: Test samples are provided with a USB interface which makes it possible to control them through test software installed on a notebook computer.

This software, Realtek UI_mptool was running on the laptop computer connected to the EUT. It was used to enable the operation modes listed in section 3.3 as appropriate.

The samples were used as follows:

Conducted: A000677355-004

Radiation: A000677355-005

Full test was applied on all test modes, but only worst case was shown

IEEE 802.11b mode:

Channel Low (2412MHz), Channel Mid (2437MHz) and Channel High (2462MHz) with 1Mbps data rate were chosen for full testing.

IEEE 802.11g mode:

Channel Low (2412MHz), Channel Mid (2437MHz) and Channel High (2462MHz) with 6Mbps data rate were chosen for full testing.

IEEE 802.11n HT 20 mode:

Channel Low (2412MHz), Channel Mid (2437MHz) and Channel High (2462MHz) with 13Mbps data rate were chosen for full testing.

4.3 Auxiliary Equipment

The product has been tested together with the following additional accessories:

Description	Manufacturer	Model No.	Serial No.
Notebook(EMC-06)	Lenovo	TP00048A	PB-0F8B2

4.4 Countermeasures to achieve EMC Compliance

The test sample which has been tested contained the noise suppression parts as described in the Constructional Data Form or the Technical Construction File. No additional measures were employed to achieve compliance.

4.5 Test Setup Diagram

Diagram of Measurement Configuration for Radiation Test

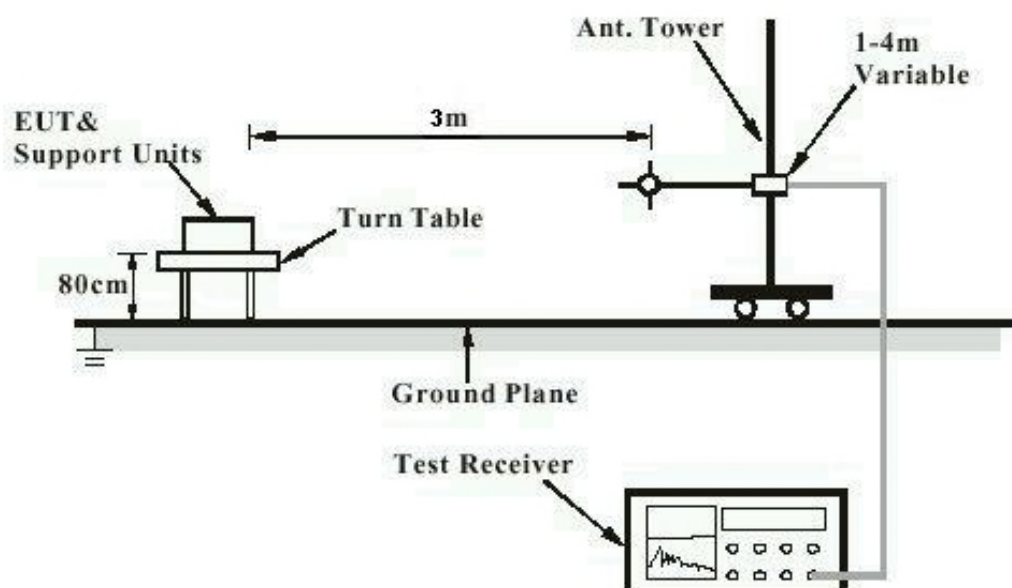

Note: Measurements above 1 GHz are done with a table height of 1.5m.

Diagram of Measurement Equipment Configuration for Mains Conduction Measurement (if applicable)

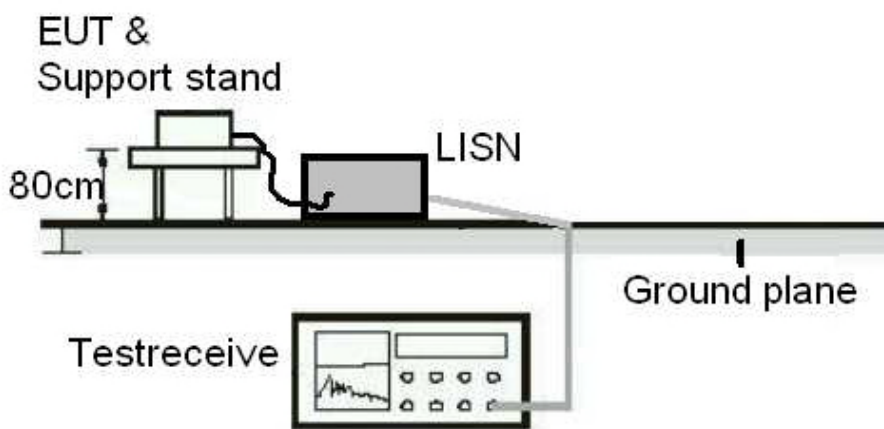
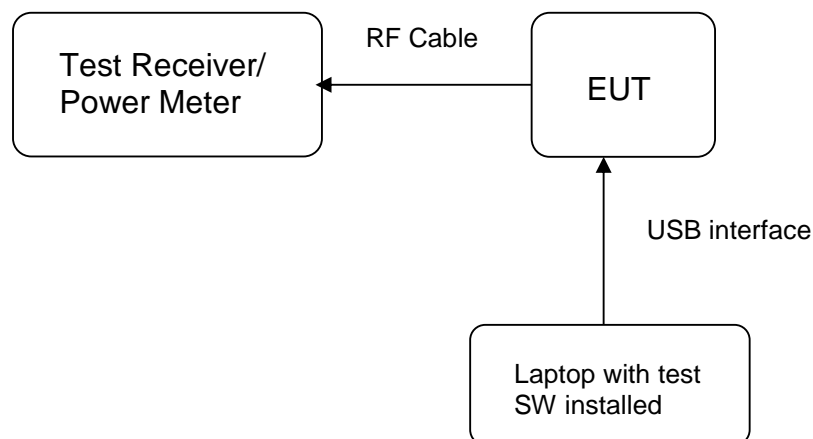

Diagram of Measurement Equipment Configuration for Conducted Transmitter Measurement



5. Test Results

5.1 Transmitter Requirement & Test Suites

5.1.1 Antenna Requirement

RESULT:**Passed**

Test standard : FCC Part 15.247(b)(4), Part 15.203 and RSS-Gen 6.8
Limit : the use of antennas with directional gains that do not exceed 6 dBi

According to the manufacturer declaration, the EUT has an antenna with a directional gain of 2.01dBi. The antenna is a Chip Antenna soldered to the PCB with no possibility of replacement with a non-approved antenna by the end-user. Therefore, the EUT is considered to comply with this provision.

Refer to EUT photo for details.

5.1.2 Peak Output Power

RESULT:
Passed

Test standard : FCC Part 15.247(b)(3), RSS-247 5.4(d)
 Basic standard : ANSI C63.10:2013, KDB558074
 Limit : 1 Watt
 Kind of test site : Shielded room/Conducted room

Test setup

Test Channel : Low/ Middle/ High
 Operation Mode : A

Table 7: Test result of Peak Output Power (802.11b)

Channel	Channel Frequency (MHz)	Output Power		Limit (W)
		(dBm)	(W)	
Low Channel	2412	21.13	0.12972	1
Middle Channel	2437	23.19	0.20845	1
High Channel	2462	24.21	0.26363	1

Table 8: Test result of Peak Output Power (802.11g)

Channel	Channel Frequency (MHz)	Output Power		Limit (W)
		(dBm)	(W)	
Low Channel	2412	24.54	0.28445	1
Middle Channel	2437	24.71	0.29580	1
High Channel	2462	24.92	0.31046	1

Table 9: Test result of Peak Output Power (802.11n HT20)

Channel	Channel Frequency (MHz)	Output Power		Limit (W)
		(dBm)	(W)	
Low Channel	2412	23.89	0.24491	1
Middle Channel	2437	24.29	0.26853	1
High Channel	2462	24.74	0.29785	1

Prüfbericht - Nr.: 50299306 001

Test Report No.

Seite 17 von 50

Page 17 of 50

5.1.3 6dB Bandwidth and 99% Bandwidth

RESULT:**Passed**

Test standard : FCC Part 15.247(a)(2), RSS-247 5.2(a)
Basic standard : ANSI C63.10:2013, KDB558074
Kind of test site : Shielded room/Conducted room

Test setup

Test Channel : Low/ Middle/ High
Operation Mode : A

Table 10: Test result of 6dB Bandwidth (802.11b)

Channel	Channel Frequency (MHz)	6dB Bandwidth (MHz)	Limit (MHz)	Result
Low Channel	2412	9.0509	>0.5	Pass
Mid Channel	2437	9.0509	>0.5	Pass
High Channel	2462	9.0509	>0.5	Pass

Table 11: Test result of 6dB Bandwidth (802.11g)

Channel	Channel Frequency (MHz)	6dB Bandwidth (MHz)	Limit (MHz)	Result
Low Channel	2412	16.5435	>0.5	Pass
Mid Channel	2437	16.5435	>0.5	Pass
High Channel	2462	16.5435	>0.5	Pass

Table 12: Test result of 6dB Bandwidth (802.11n HT20)

Channel	Channel Frequency (MHz)	6dB Bandwidth (MHz)	Limit (MHz)	Result
Low Channel	2412	17.6823	>0.5	Pass
Mid Channel	2437	17.7722	>0.5	Pass
High Channel	2462	17.6823	>0.5	Pass

Table 13: Test result of 99% Bandwidth (802.11b)

Channel	Channel Frequency (MHz)	99% Bandwidth (MHz)
Low Channel	2412	13.186
Mid Channel	2437	13.396
High Channel	2462	13.966

Table 14: Test result of 99% Bandwidth (802.11g)

Channel	Channel Frequency (MHz)	99% Bandwidth (MHz)
Low Channel	2412	16.483
Mid Channel	2437	16.483
High Channel	2462	16.543

Table 15: Test result of 99% Bandwidth (802.11n HT20)

Channel	Channel Frequency (MHz)	99% Bandwidth (MHz)
Low Channel	2412	17.622
Mid Channel	2437	17.652
High Channel	2462	17.652

Test Plot of 6dB Bandwidth and Test Plot of 99% Bandwidth (802.11b)

Low Channel

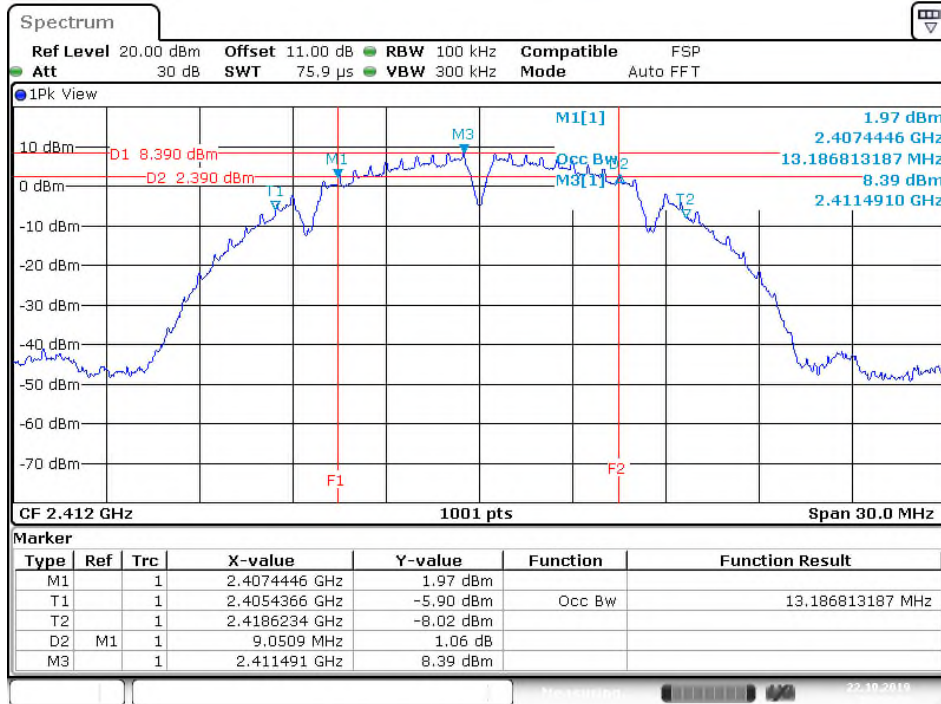

Date: 22.OCT.2019 11:14:30

Middle Channel

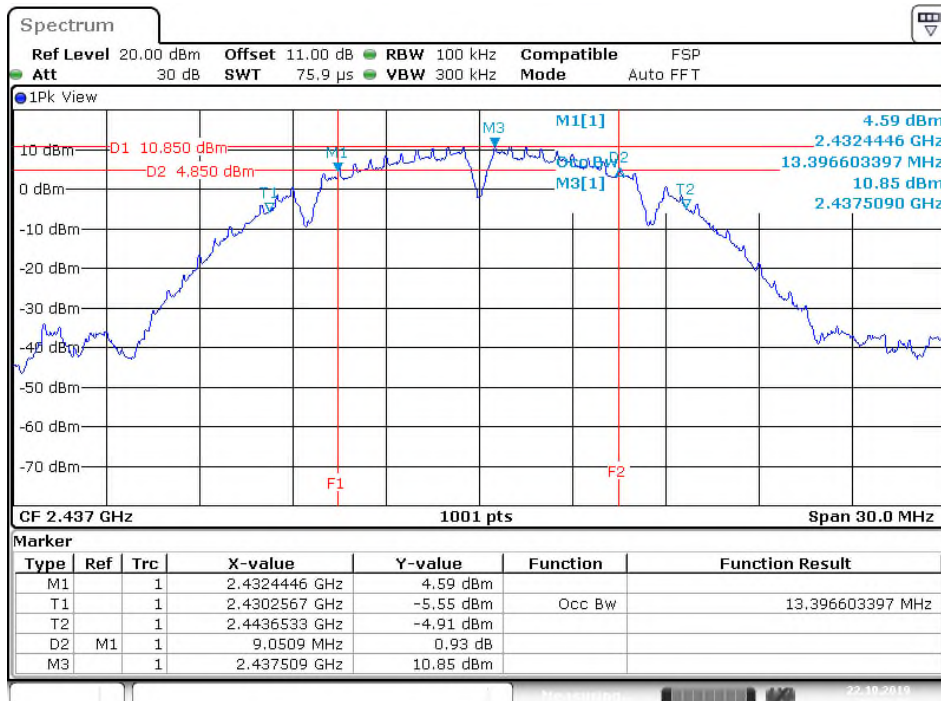

Date: 22.OCT.2019 11:24:26

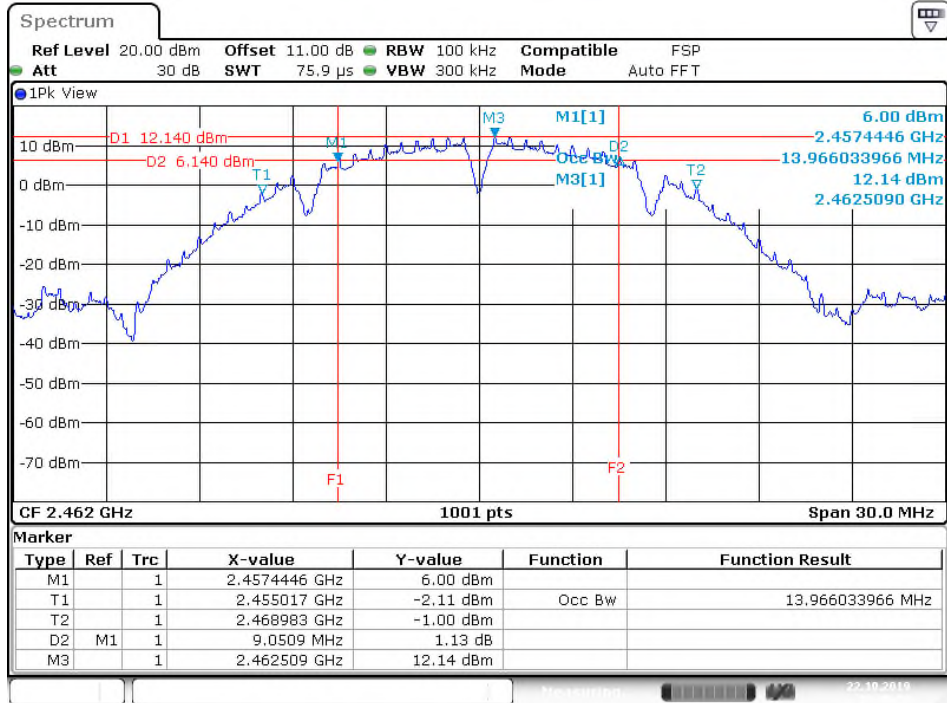
High Channel

Date: 22.OCT.2019 11:30:11

Test Plot of 6dB Bandwidth and Test Plot of 99% Bandwidth (802.11g)

Low Channel

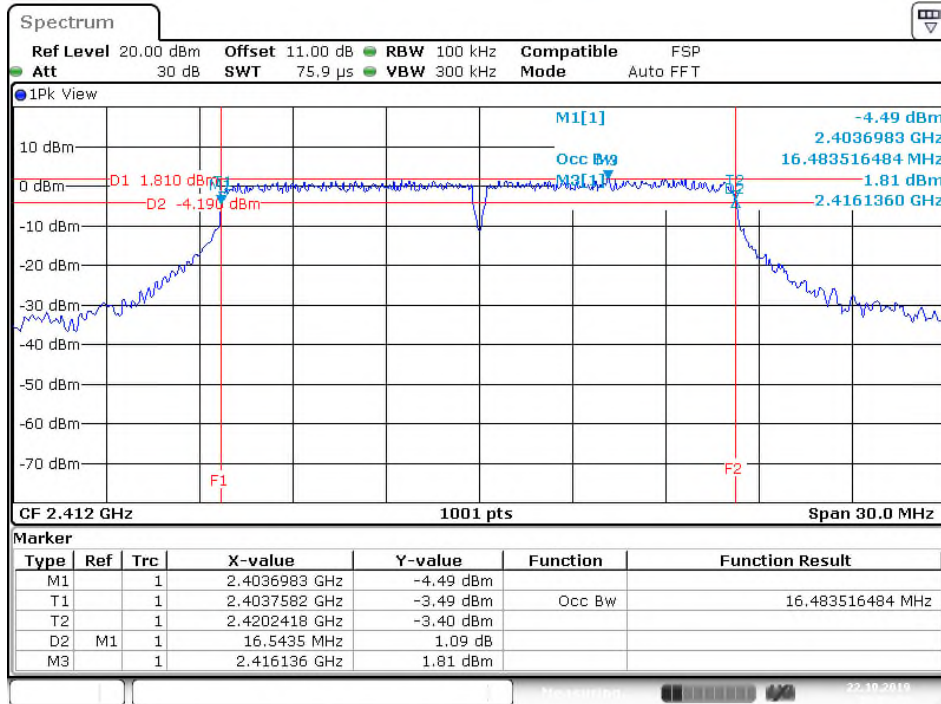

Middle Channel

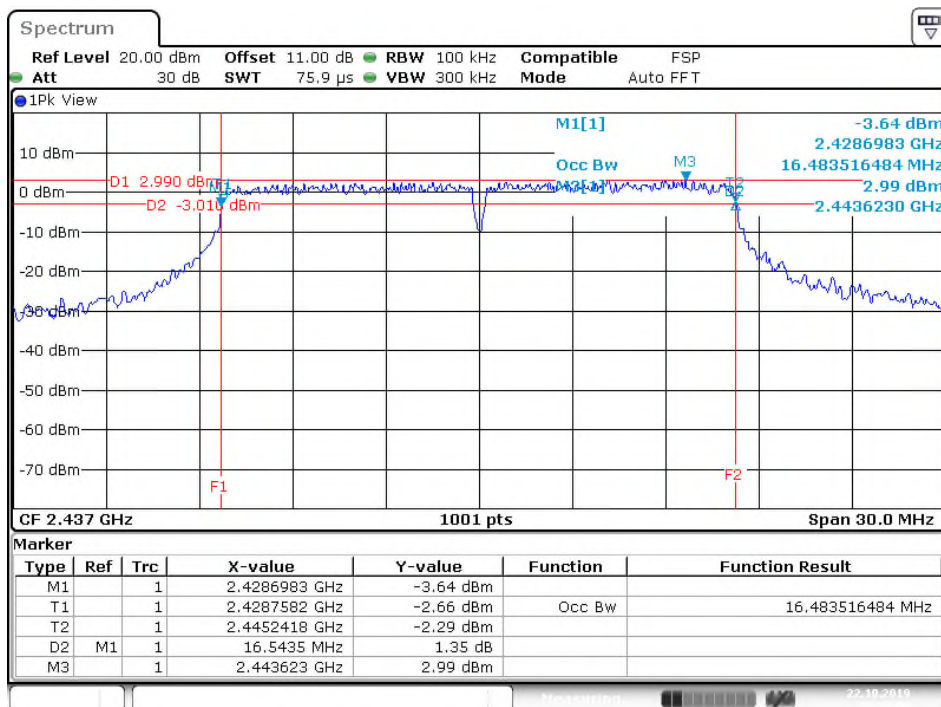

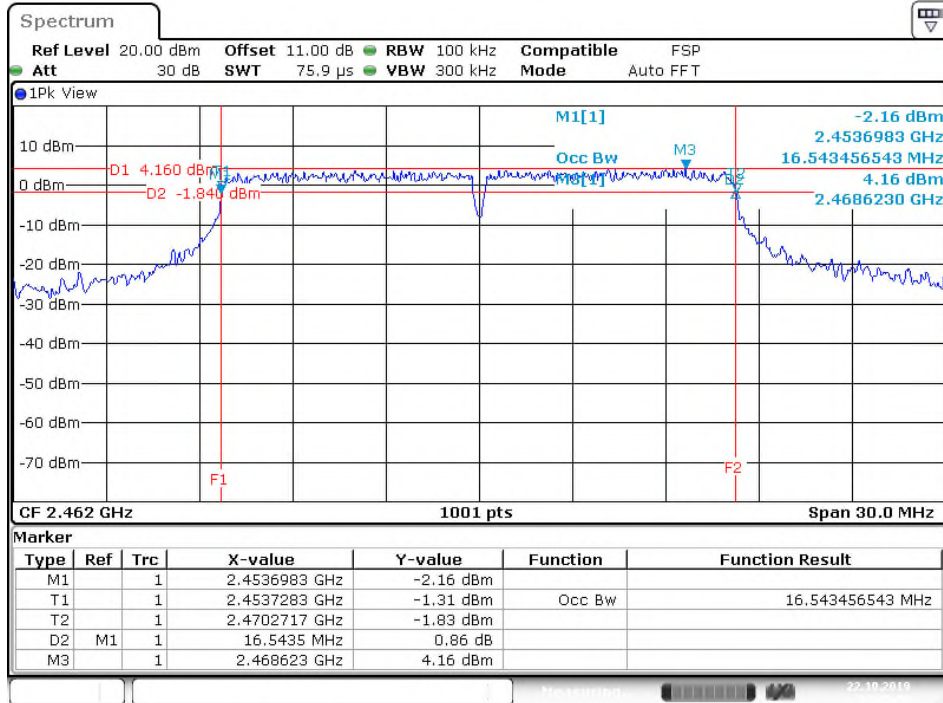
High Channel

Date: 22.OCT.2019 14:55:00

Test Plot of 6dB Bandwidth and Test Plot of 99% Bandwidth (802.11n HT20)

Low Channel

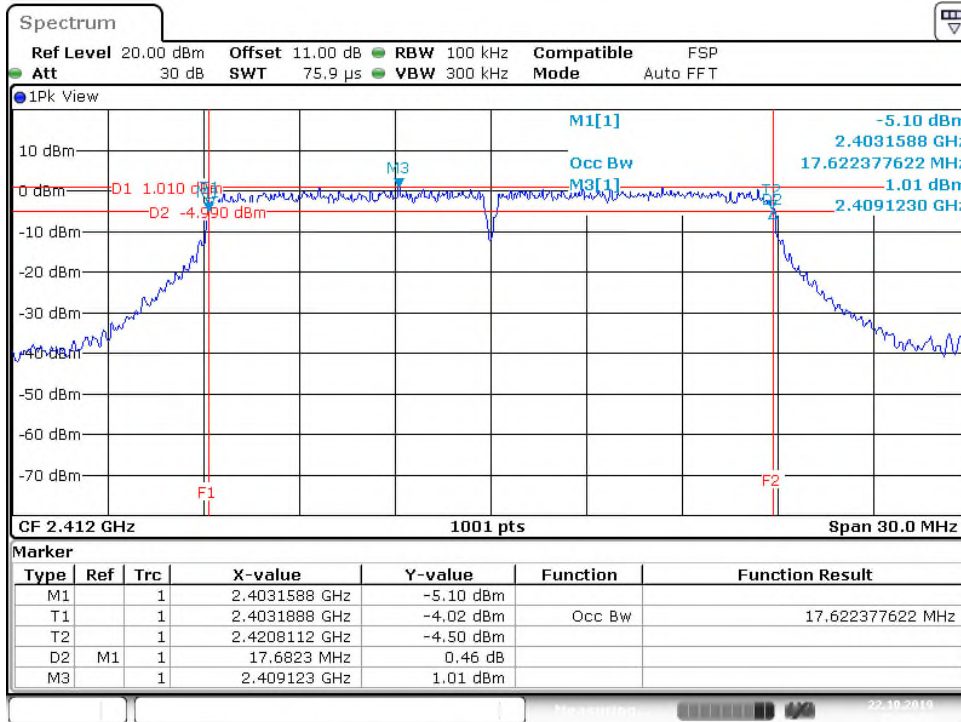

Middle Channel

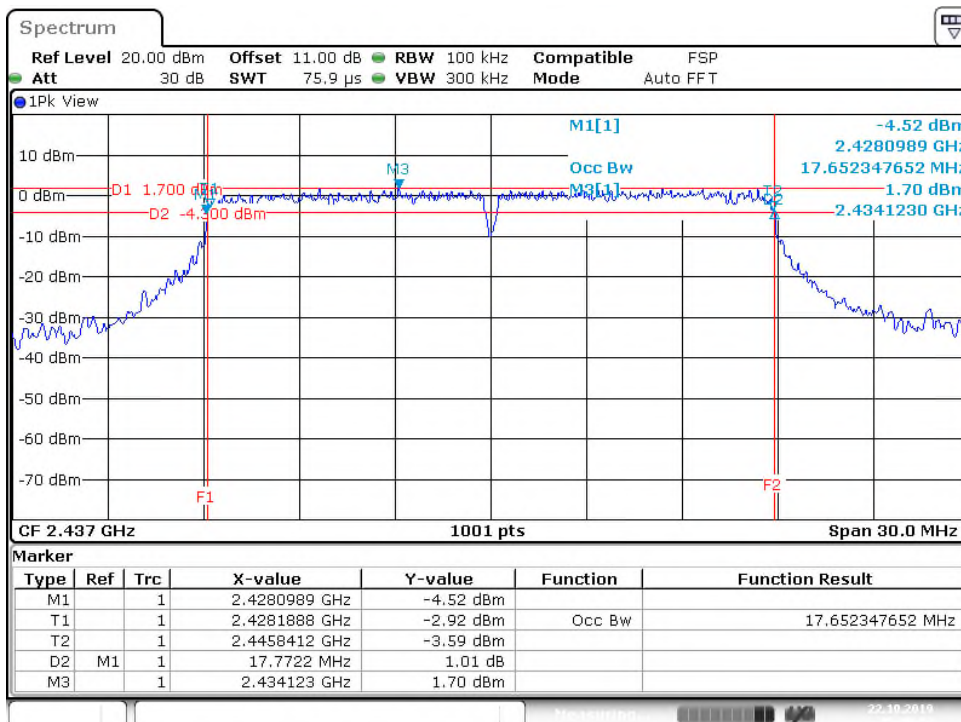

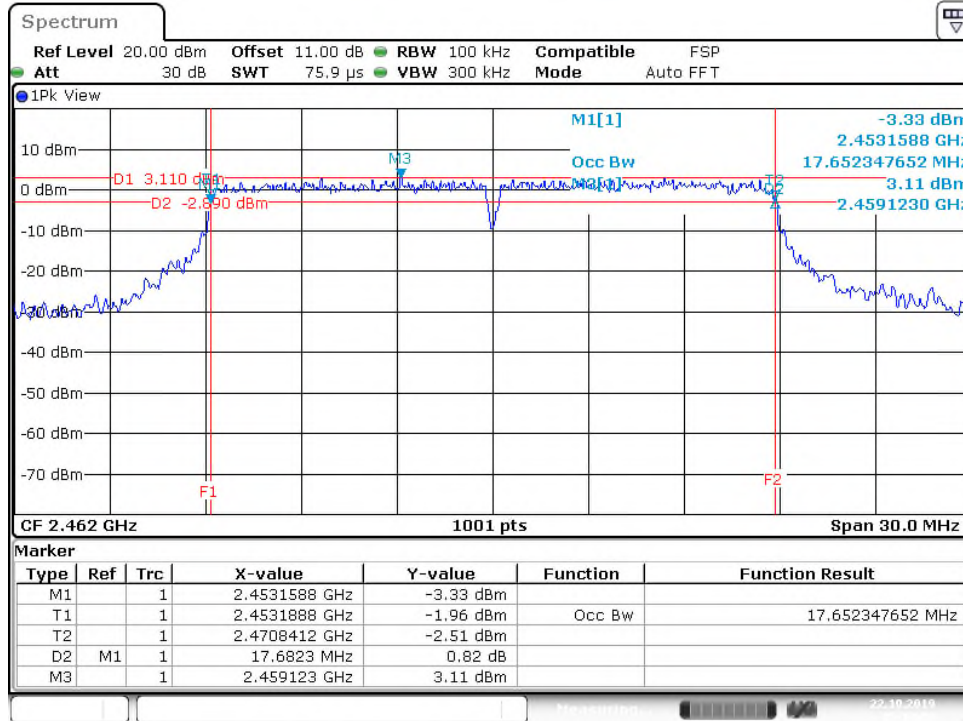
High Channel

Date: 22.OCT.2019 15:14:03

5.1.4 Power Density

RESULT:
Passed

Test standard : FCC Part 15.247(e) , RSS-247 5.2(b)
 Basic standard : ANSI C63.10:2013, KDB558074
 Kind of test site : Shielded room/Conducted room

Test setup

Test Channel : Low/ Middle/ High
 Operation Mode : A

Table 16: Test result of Power Density (802.11b)

Channel	Channel Frequency (MHz)	Power Density	Limit
		(dBm)	(dBm)
Low Channel	2412	-12.03	8
Middle Channel	2437	-9.73	8
High Channel	2462	-8.15	8

Table 17: Test result of Power Density (802.11g)

Channel	Channel Frequency (MHz)	Power Density	Limit
		(dBm)	(dBm)
Low Channel	2412	-12.79	8
Middle Channel	2437	-11.78	8
High Channel	2462	-10.66	8

Table 18: Test result of Power Density (802.11n HT20)

Channel	Channel Frequency (MHz)	Power Density	Limit
		(dBm)	(dBm)
Low Channel	2412	-13.13	8
Middle Channel	2437	-12.04	8
High Channel	2462	-11.14	8

Test Plot of Power Density (802.11b)

Low Channel

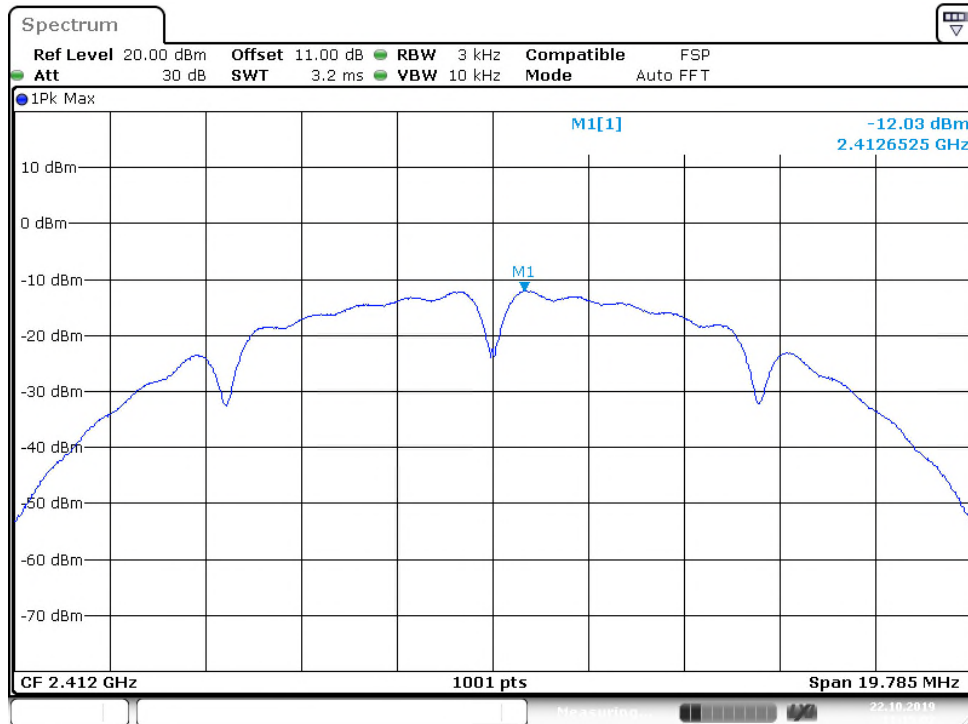

Date: 22.OCT.2019 11:15:02

Middle Channel

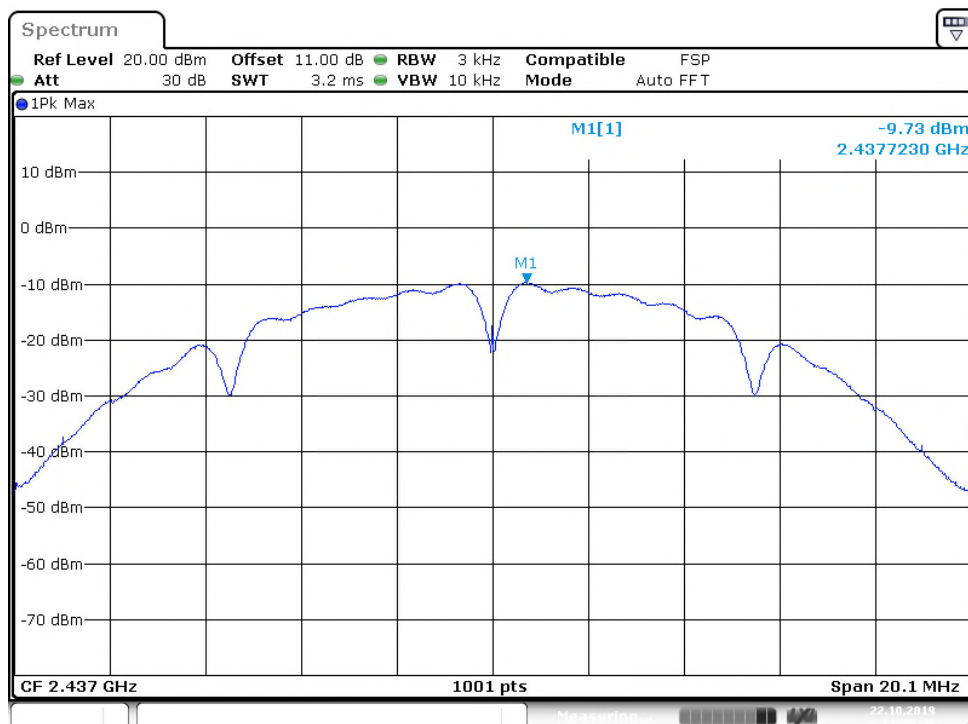

Date: 22.OCT.2019 11:25:43

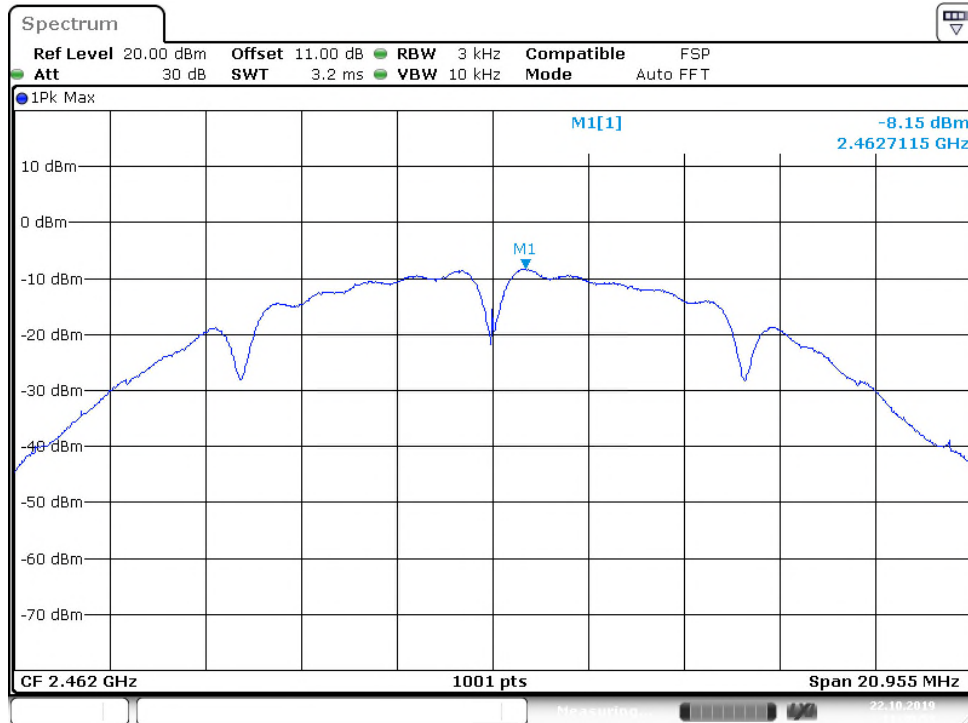
High Channel

Date: 22.OCT.2019 11:30:53

Test Plot of Power Density (802.11g)

Low Channel

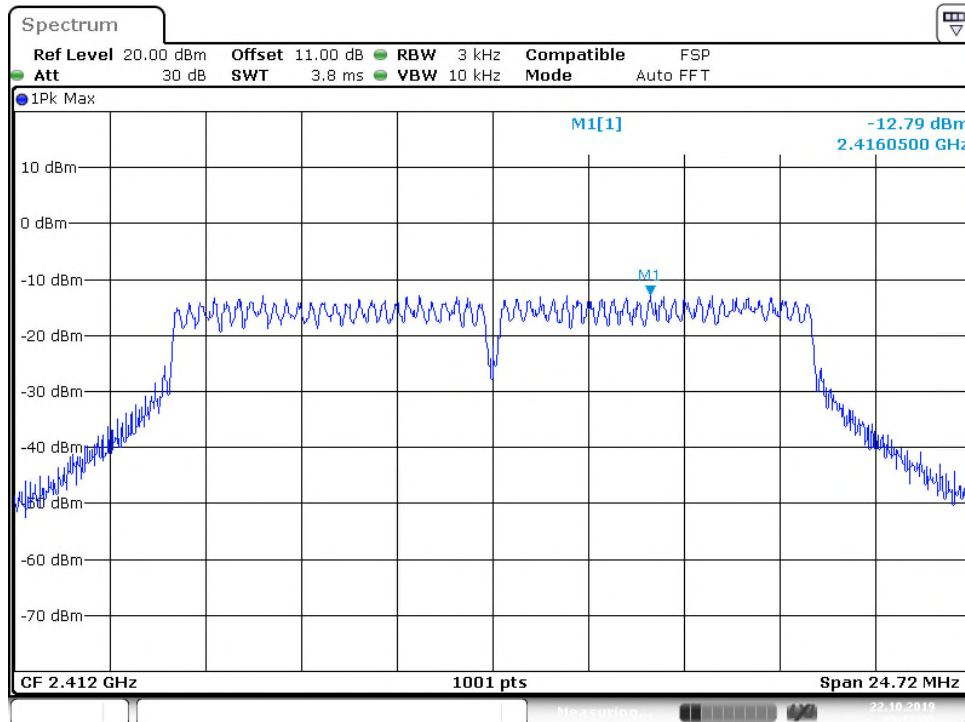

Date: 22.OCT.2019 13:12:05

Middle Channel

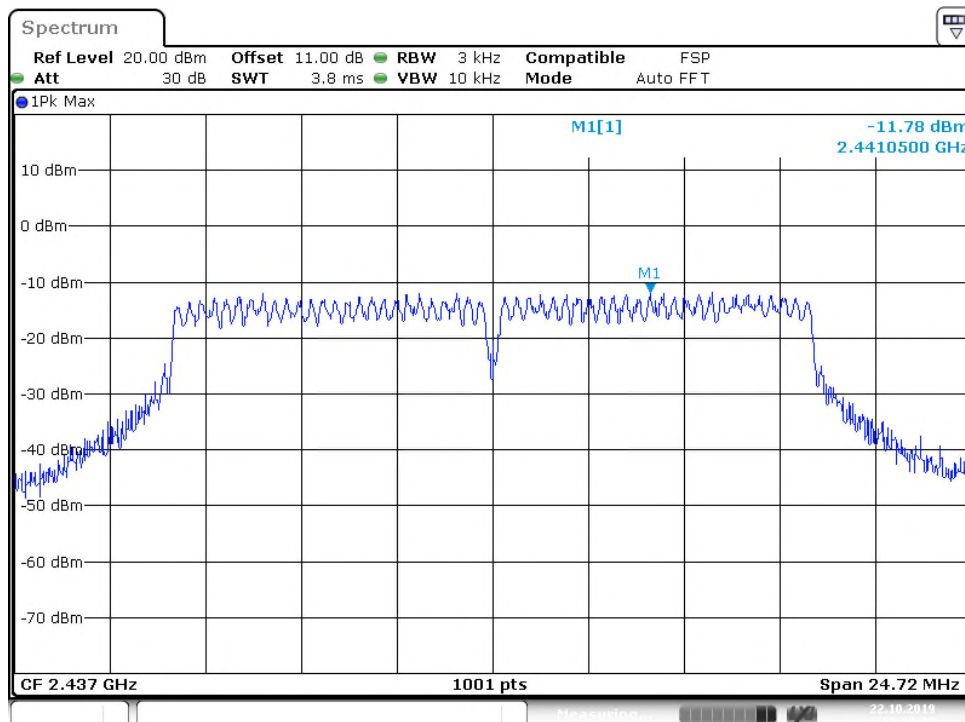

Date: 22.OCT.2019 13:18:17

High Channel

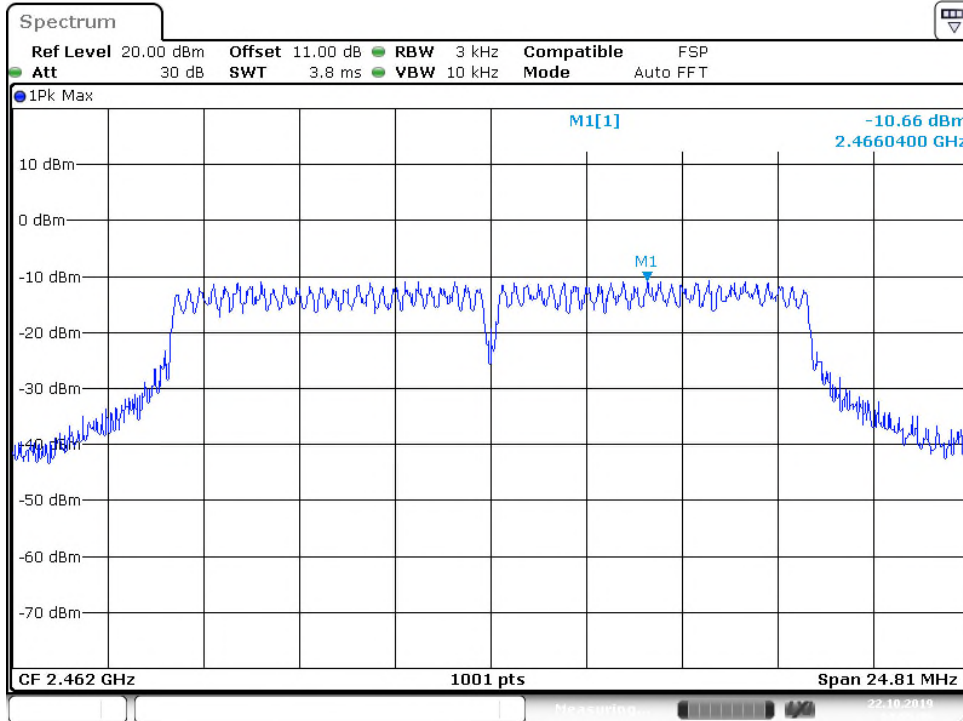

Date: 22.OCT.2019 14:55:36

Test Plot of Power Density (802.11n HT20)

Low Channel

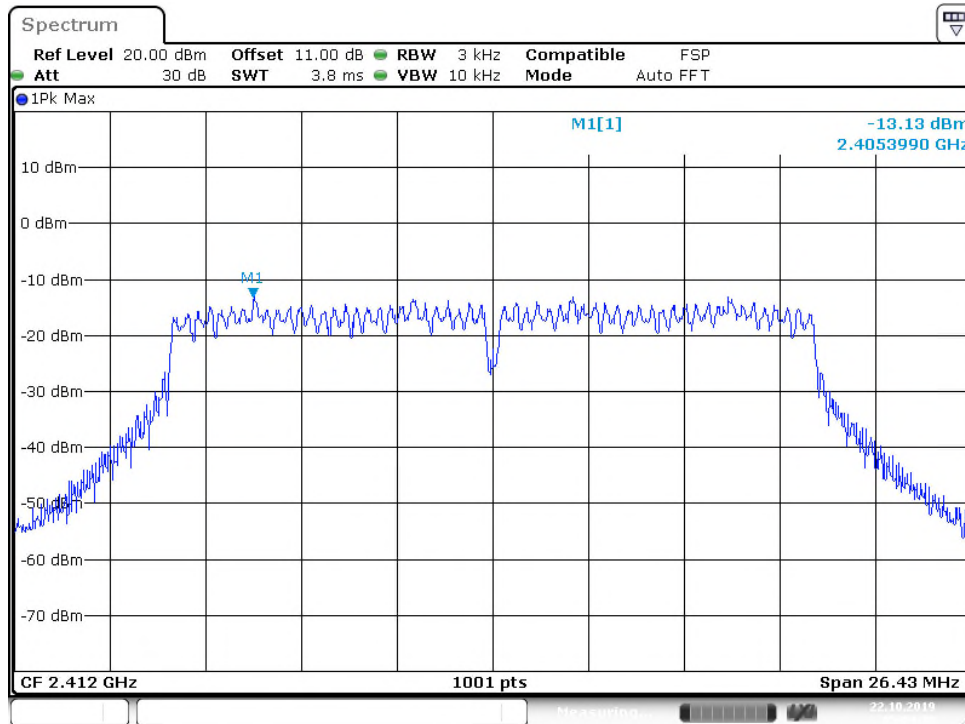

Middle Channel

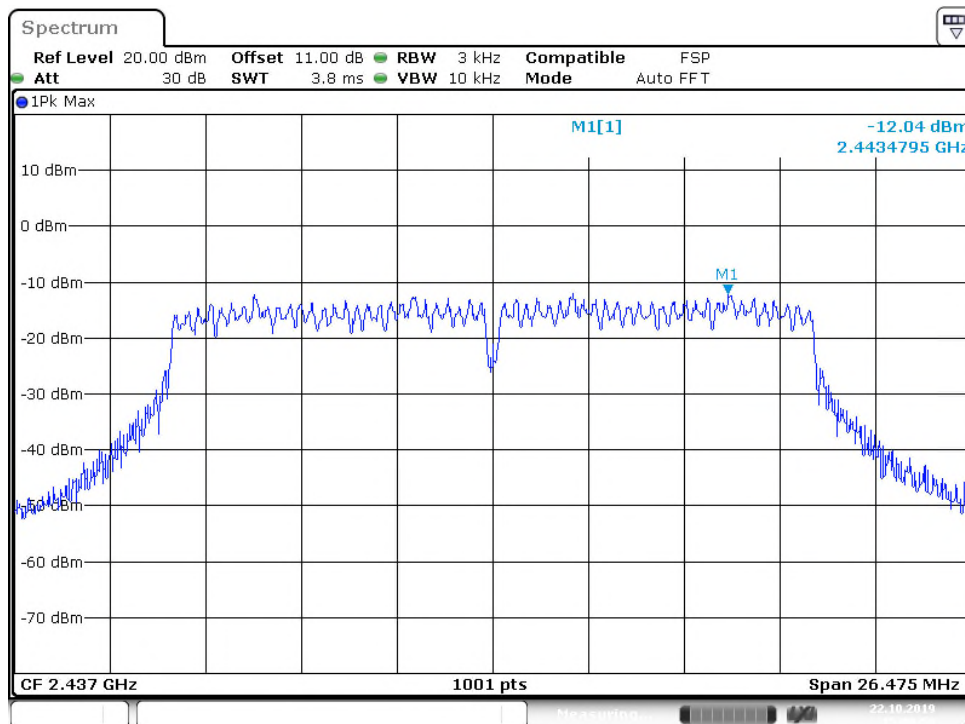

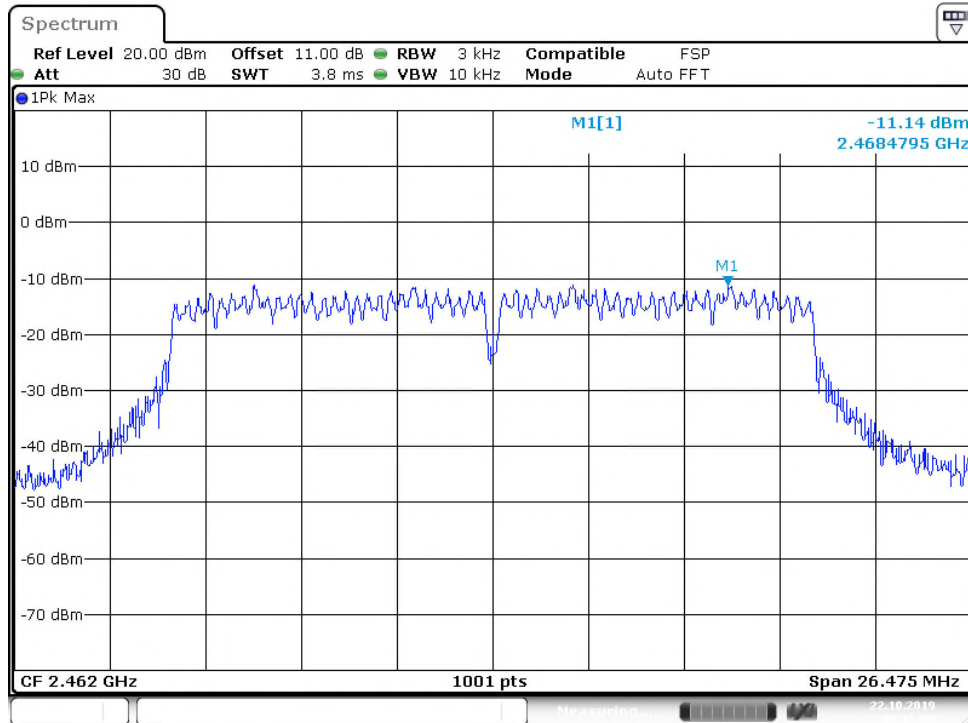
High Channel

Date: 22.OCT.2019 15:15:33

5.1.5 Conducted spurious emissions and Frequency Band Edge measured in 100kHz Bandwidth

RESULT:**Passed**

Test standard : FCC part 15.247(d), RSS-247 5.5
Basic standard : ANSI C63.10:2013, KDB558074
Limit : 20dB (below that in the 100kHz bandwidth within the band that contains the highest level of the desired power)
Kind of test site : Shielded room/Conducted room

Test setup

Test Channel : Low/ High
Operation mode : A

All emissions are more than 20dB below fundamental, details refer to following test plot, and compliance is achieved as well.

Due to the small size of the product and that there are no inductive components of significant size, 9kHz to 30MHz frequency range is not tested based on technical judgment.

Test Plot 100kHz Conducted Emissions (802.11b)

Low Channel

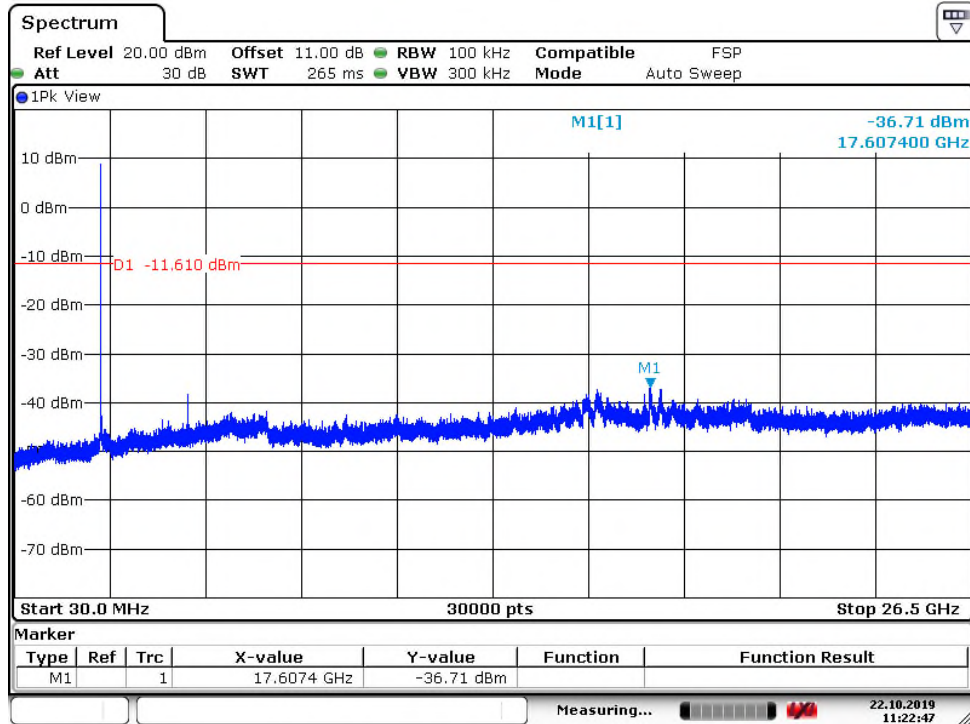

Date: 22.OCT.2019 11:22:47

Middle Channel

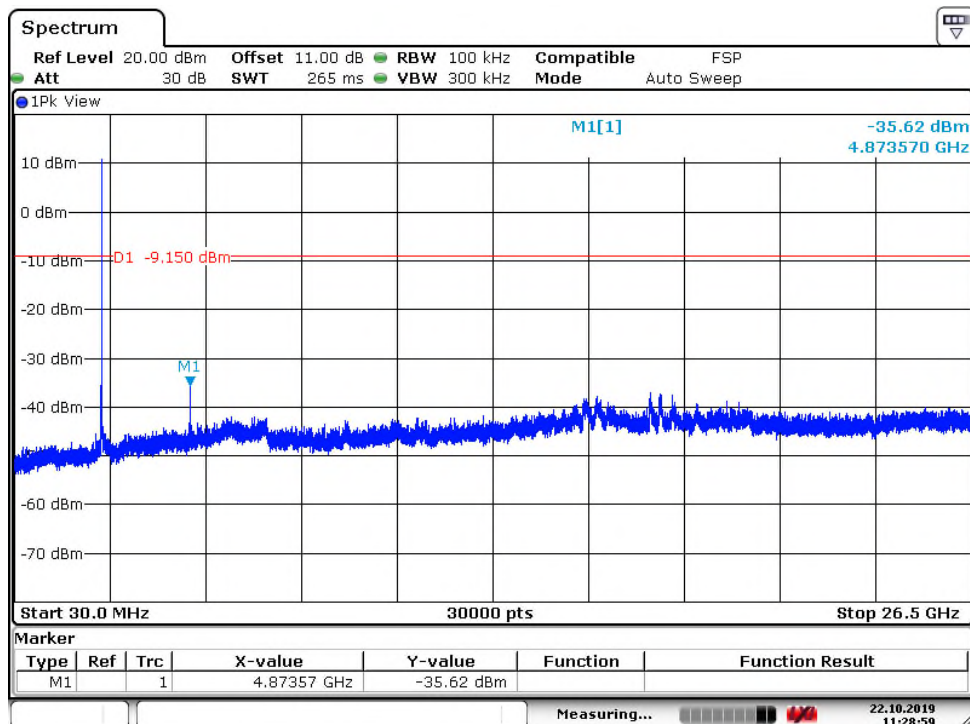

Date: 22.OCT.2019 11:28:58

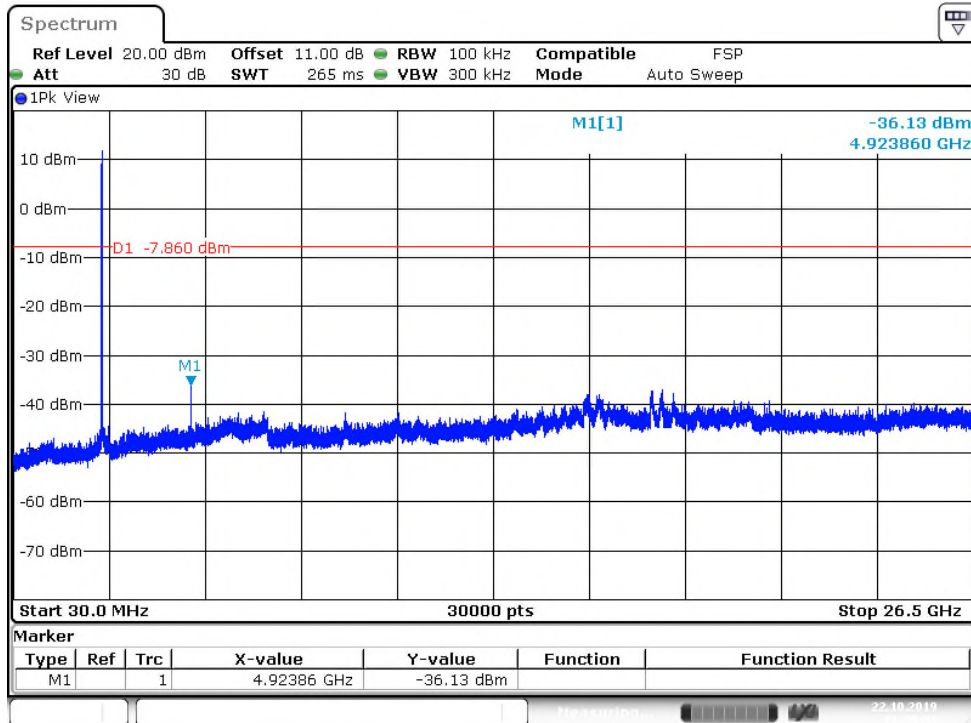
High Channel

Test Plot 100kHz Conducted Emissions (802.11g)

Low Channel

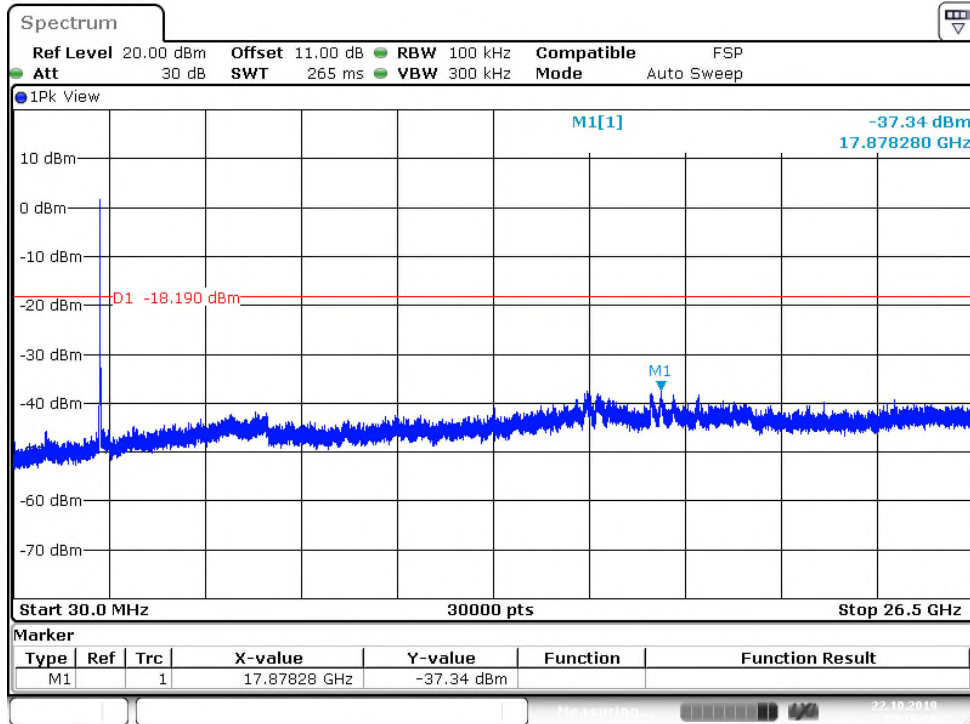

Middle Channel

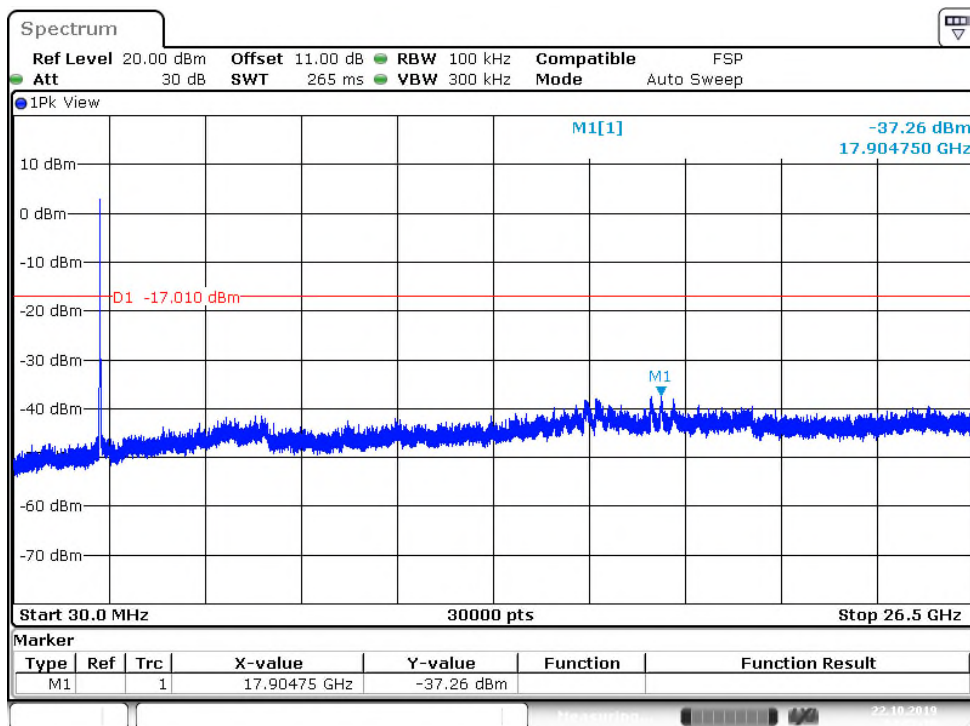

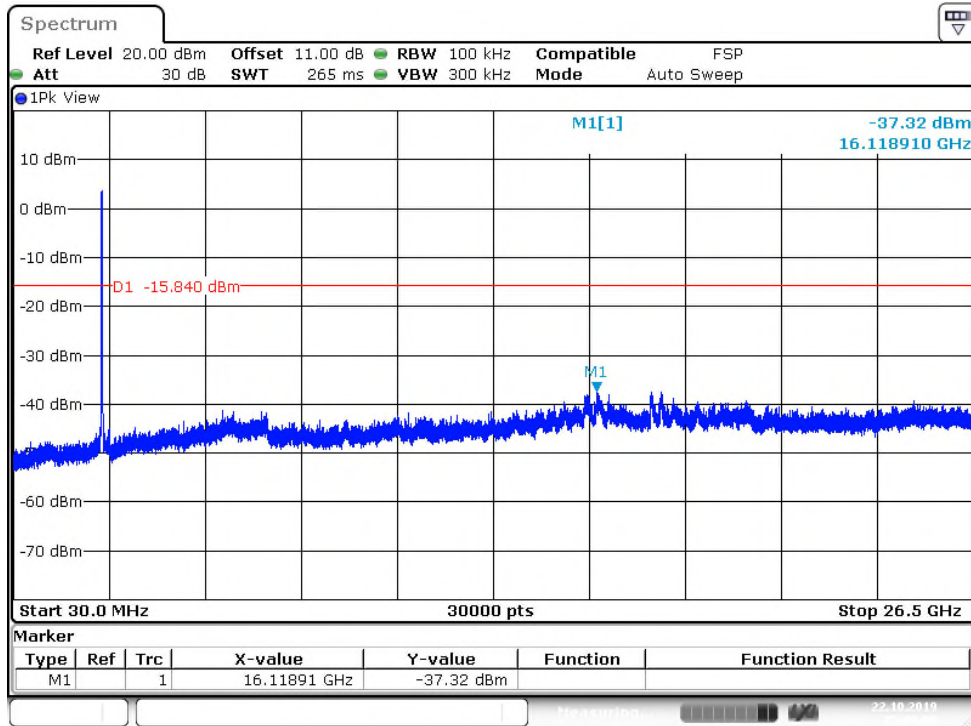
High Channel

Test Plot 100kHz Conducted Emissions (802.11n HT20)

Low Channel

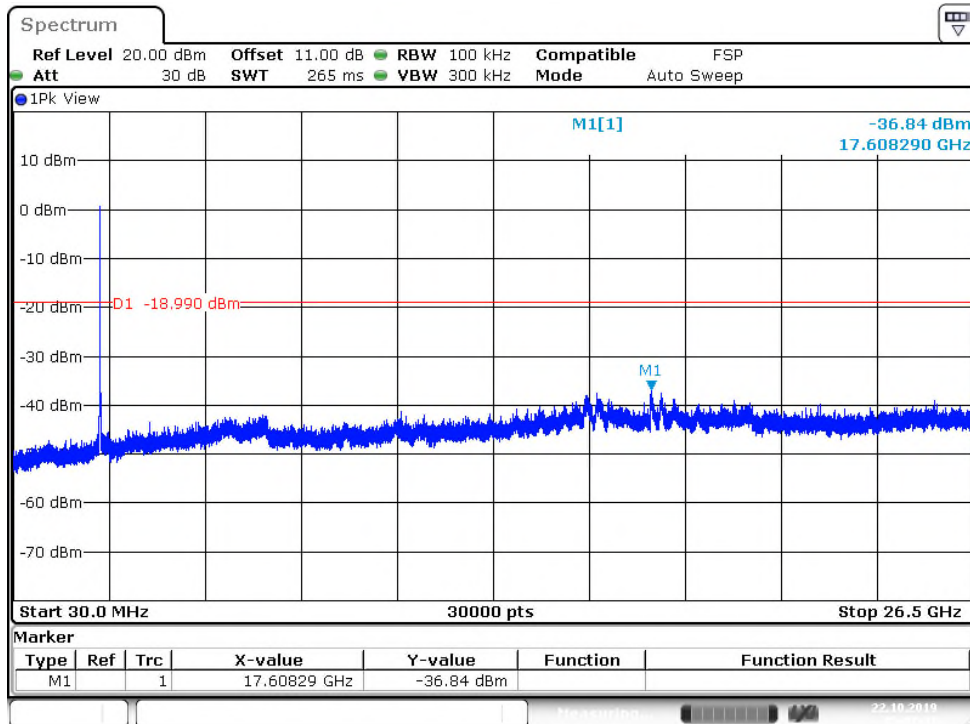

Middle Channel

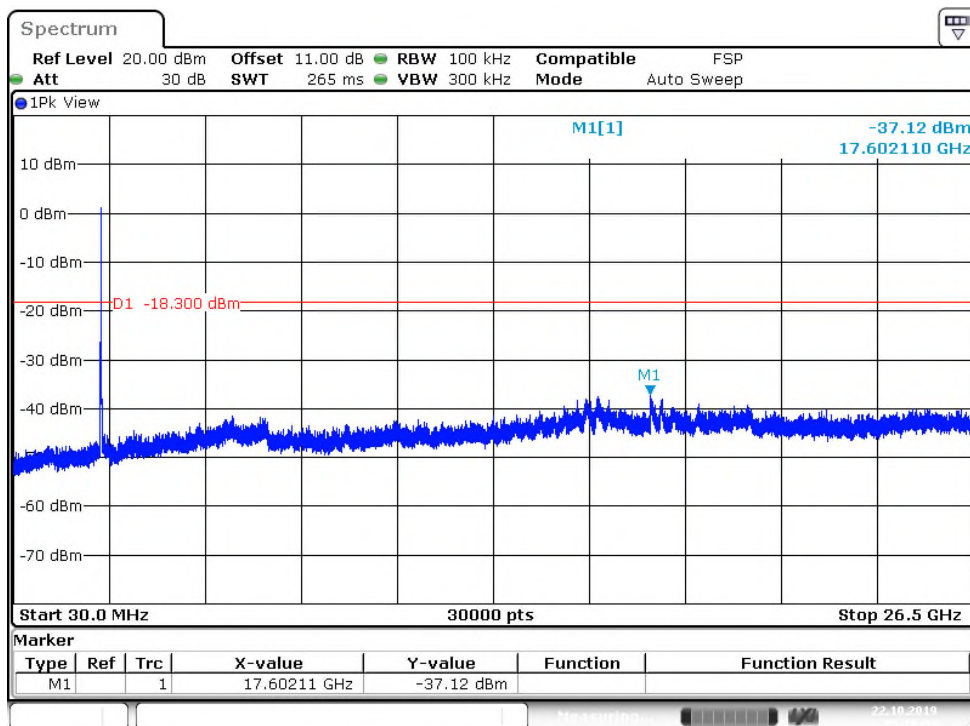

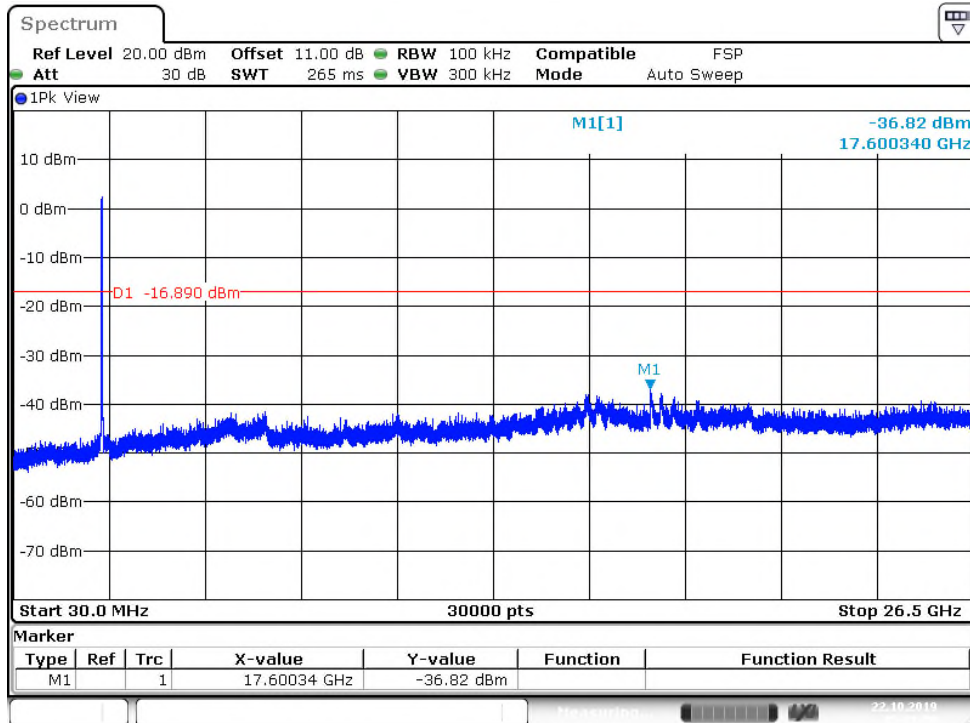
High Channel

Test Plot 100kHz RBW of Band Edge (802.11b)

Low Channel

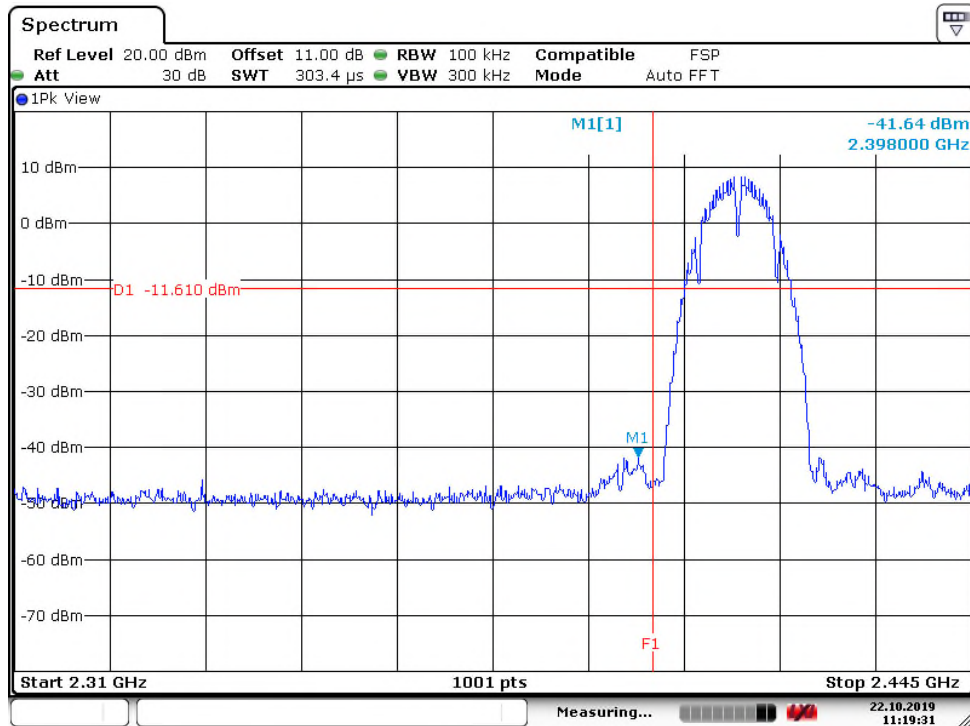

Date: 22.OCT.2019 11:19:31

High Channel

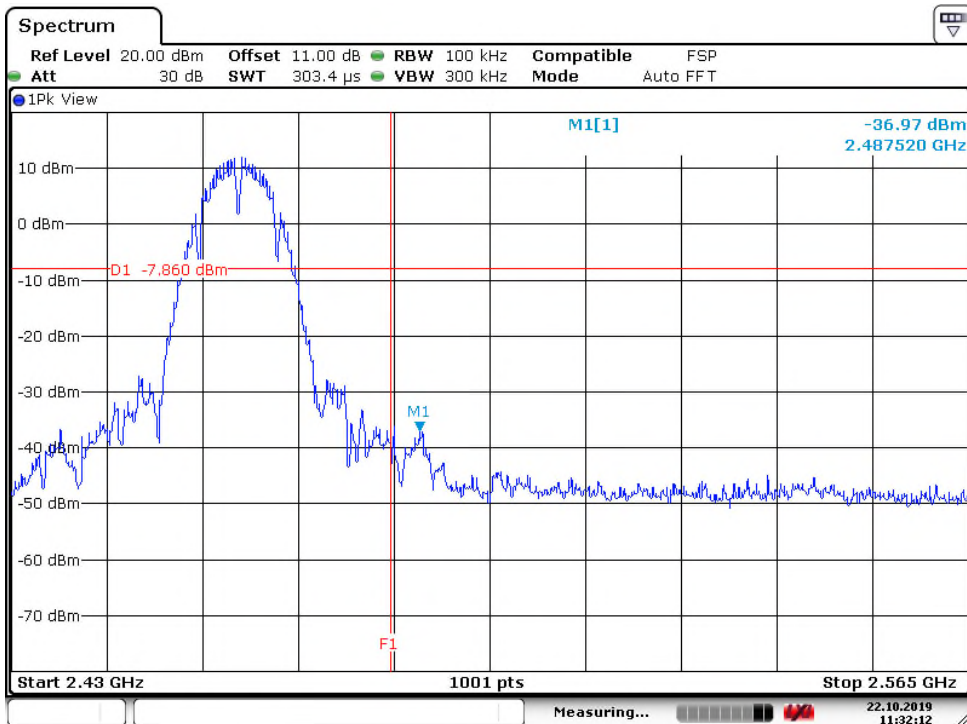

Date: 22.OCT.2019 11:32:12

Test Plot 100kHz RBW of Band Edge (802.11g)

Low Channel

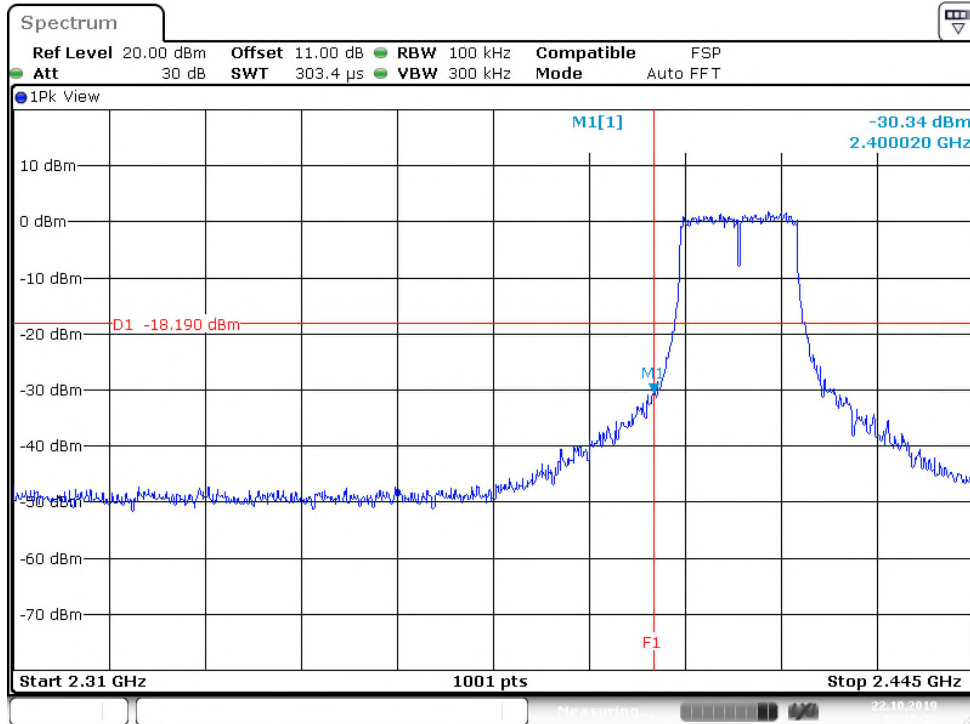

High Channel

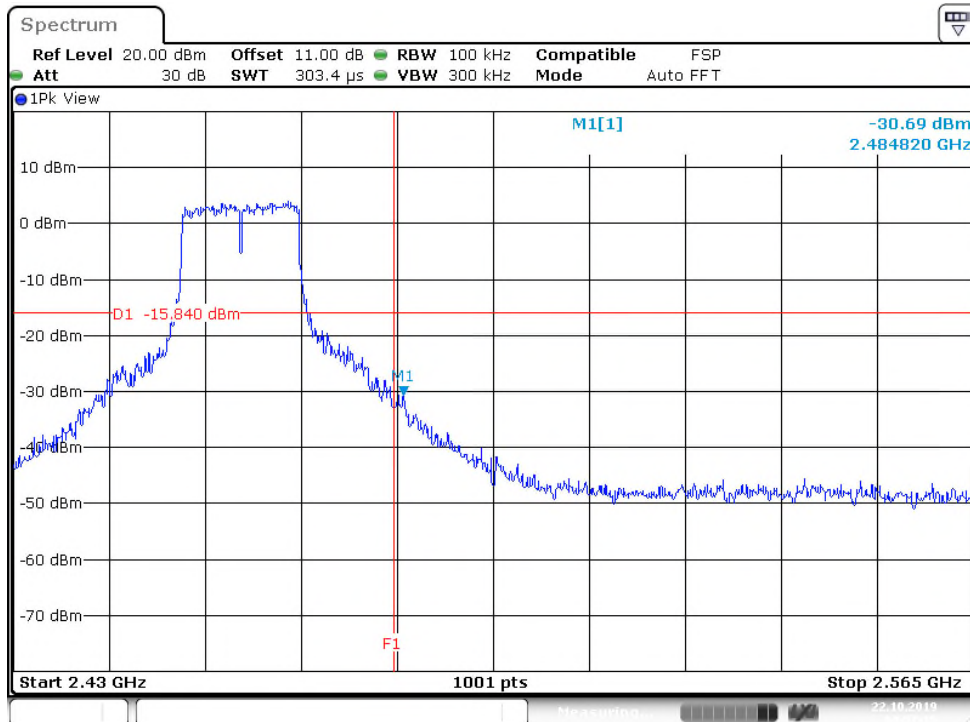

Test Plot 100kHz RBW of Band Edge (802.11n HT20)

Low Channel

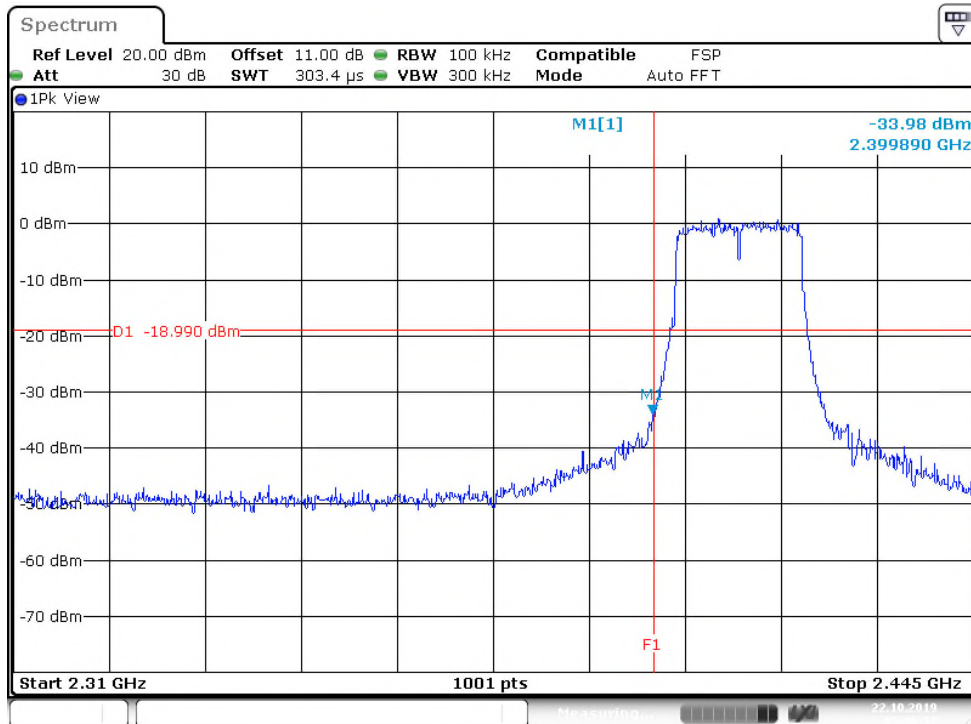

High Channel

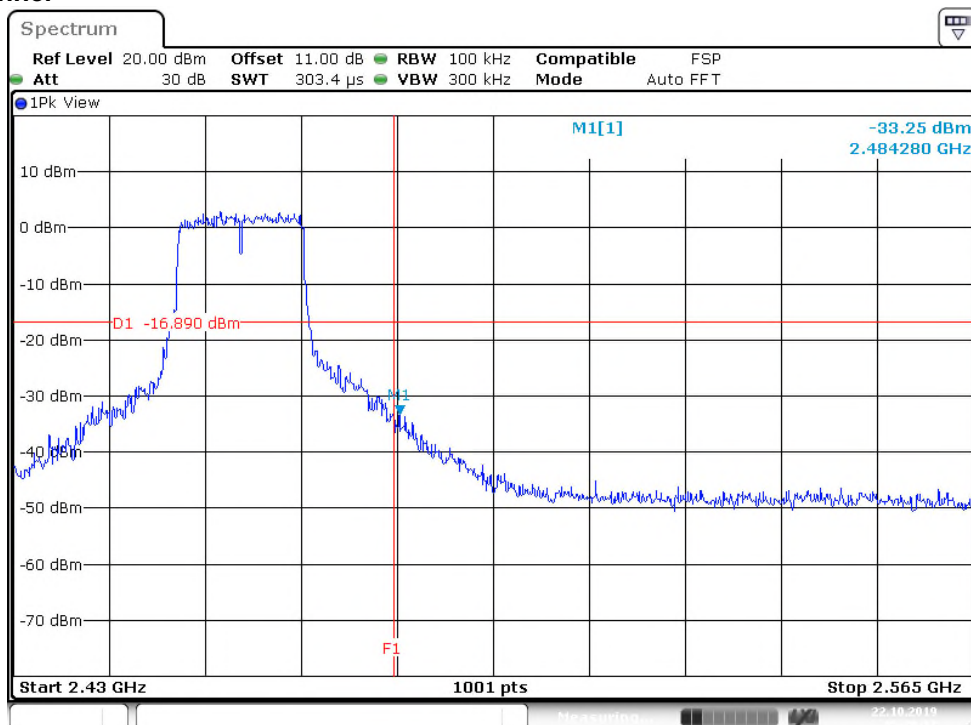

5.1.6 Spurious Emission

RESULT:**Passed**

Test standard : FCC part 15.247(d), FCC 15.205, FCC 15.209,
RSS-Gen 8.10 and RSS-Gen 8.9

Basic standard : ANSI C63.10:2013
Limits : Radiated emissions which fall in the restricted
bands, as defined in FCC 15.205(a) and RSS-
Gen i5, 8.10 (Table 7), must comply with the
radiated emission limits specified in FCC
15.209(a) and RSS-Gen i5, 8.9 (Table 5 and
6).

Emission radiated outside the specified
frequency bands must comply with the
radiated emission limits specified in FCC
15.247(d) and RSS-247 i2, 5.5.

Kind of test site : 3m Semi-Anechoic Chamber

Test setup

Test Channel : Low/ Middle/ High
Operation mode : A

Remark: Testing was carried out within frequency range 9kHz to the tenth harmonic.

For details refer to Appendix D.

The Radiated Emissions testing was performed in the X, Y and Z axis orientation. The X Axis orientation is the worst-case and recorded in this test report.

Prüfbericht - Nr.: 50299306 001

Test Report No.

Seite 44 von 50

Page 44 of 50

5.1.7 Mains Conducted Emissions

RESULT:**Passed**

Test standard : FCC Part 15.207
FCC Part 15.107
RSS-Gen 8.8

Limits : Mains Conducted emissions as defined in
above standards

Kind of test site : Shielded Room

Test setup

Test Channel : Middle
Operation mode : A

Remark: For details refer to Appendix D.

6. Safety Human exposure

6.1 Radio Frequency Exposure Compliance

6.1.1 Electromagnetic Fields

RESULT:**Passed**

Test standard : FCC 47 CFR Part 2:Subpart J Section 2.1091
FCC KDB Publication 447498 D01 v06
RSS-102 Issue 5

Separation distance is more than 20 cm, thus mobile device exposure limits can be applied

Maximum Exposure:

Power to Antenna (mW)	310.46 mW
Power to Antenna (dBm)	24.9 dBm
Antenna Gain	2.01 dBi
Power+Ant Gain	493.2 mW
Distance	20 cm
S=	0.098 mW/cm ²

Limit FCC:
1500-100,000 MHz 1.0 mW/cm²

Limit Canada: 0.544 mW/cm²

---End---

Photographs of the Test Set-Up

Photograph 1: Set-up for Spurious Emissions (Front View)



Photograph 2: Set-up for Spurious Emissions (Back View 1)

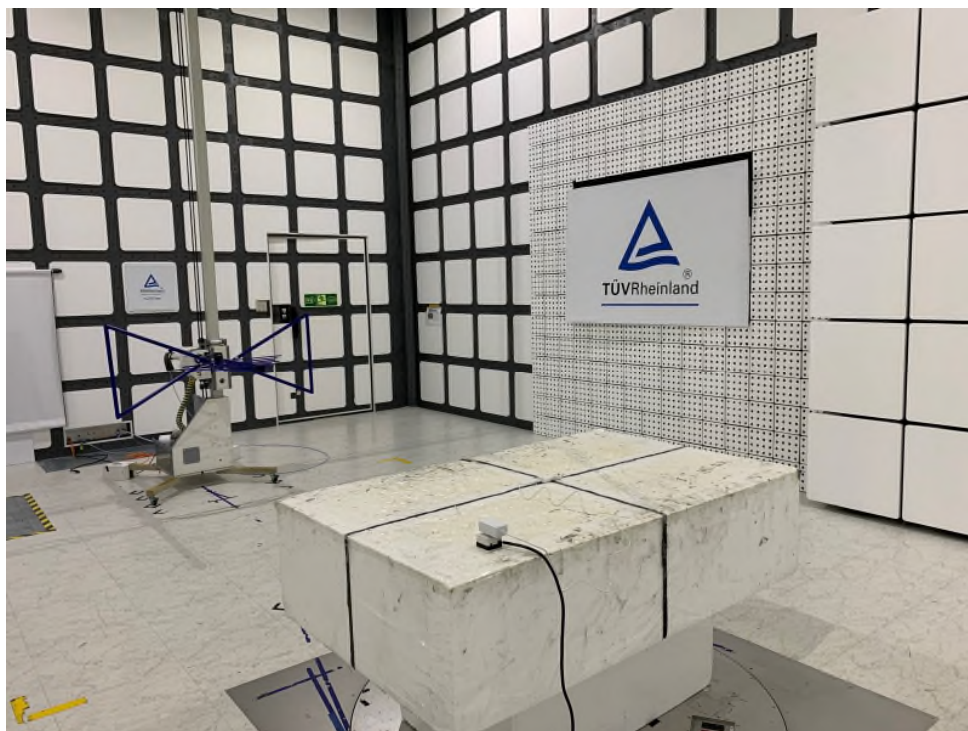

Photograph 3: Set-up for Spurious Emissions (Back View 2)

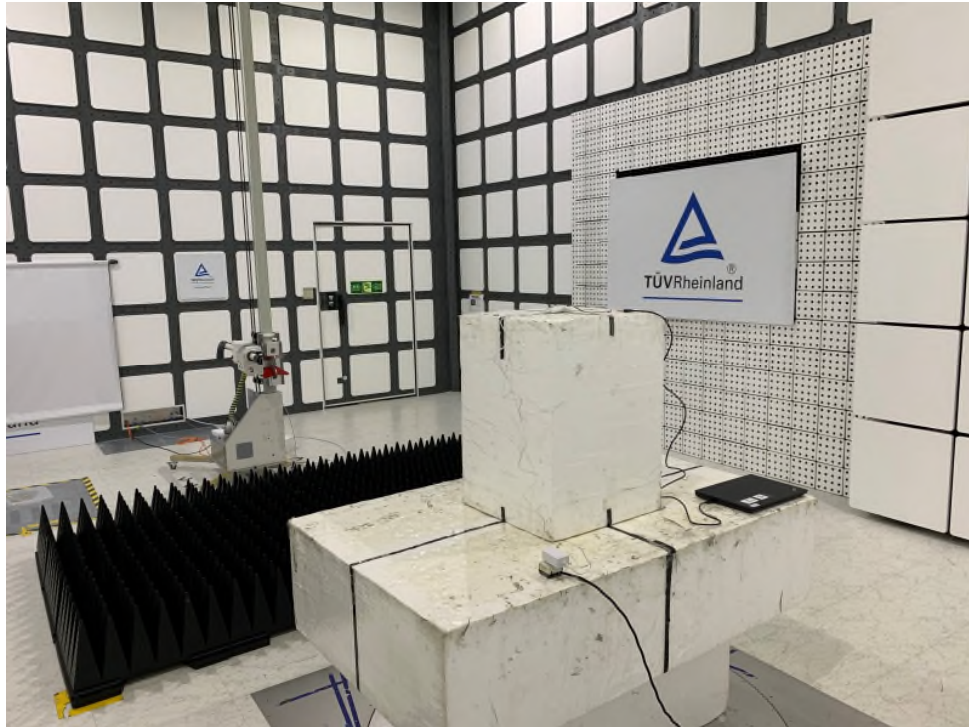

Photograph 4: Set-up for Spurious Emissions (Back View 3)

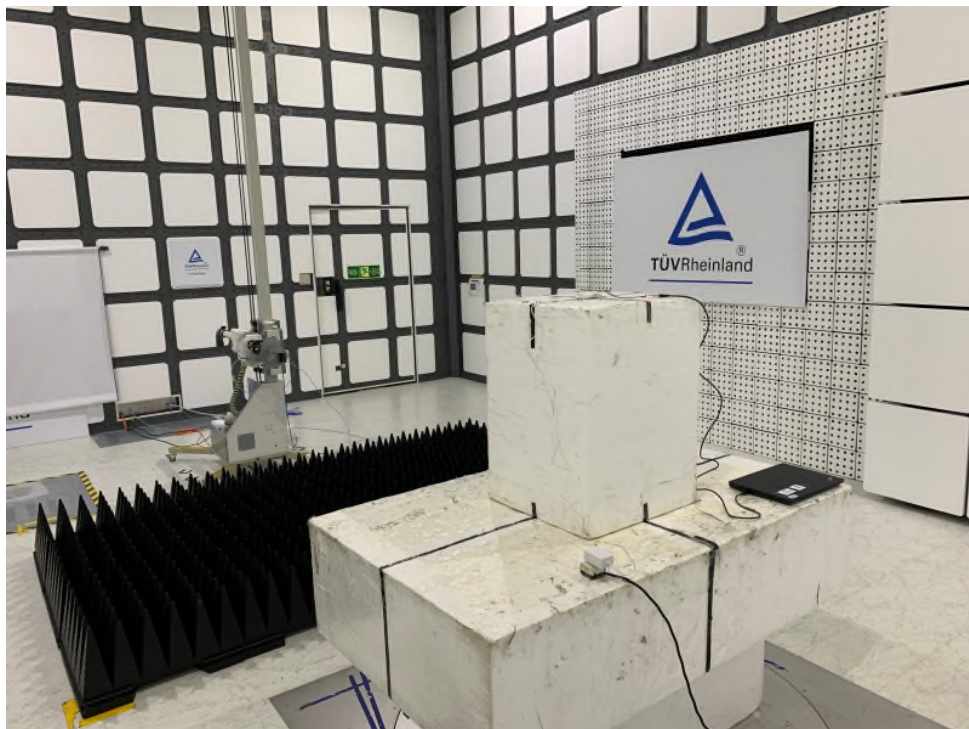

Photograph 5: Set-up for Conducted testing

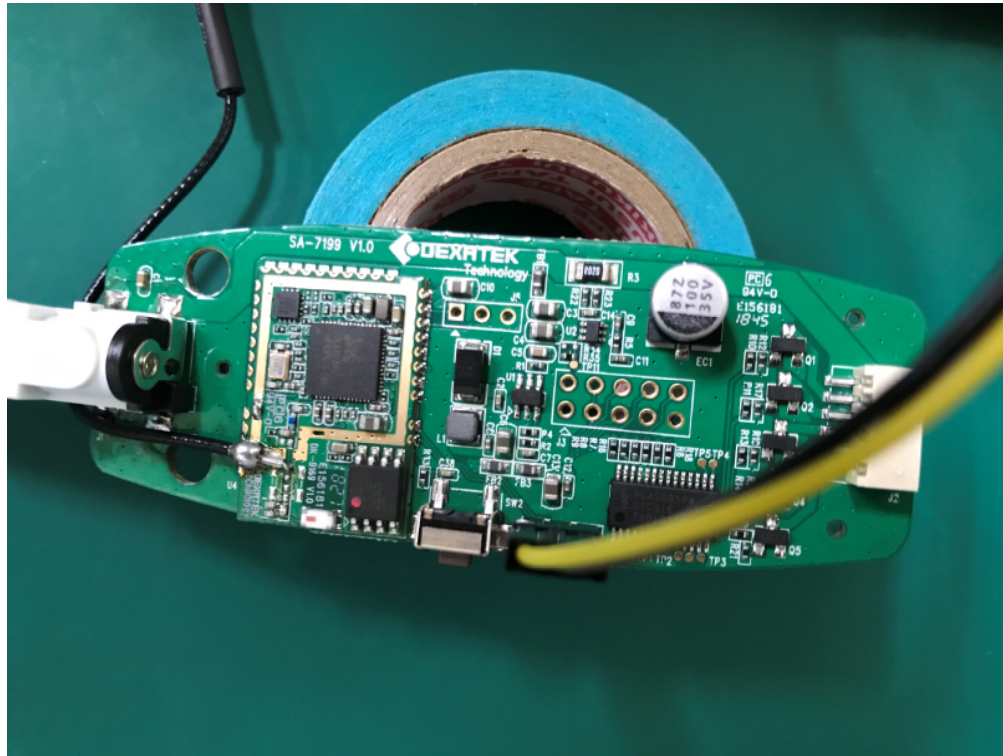

Photograph 6: Set-up for Conducted testing

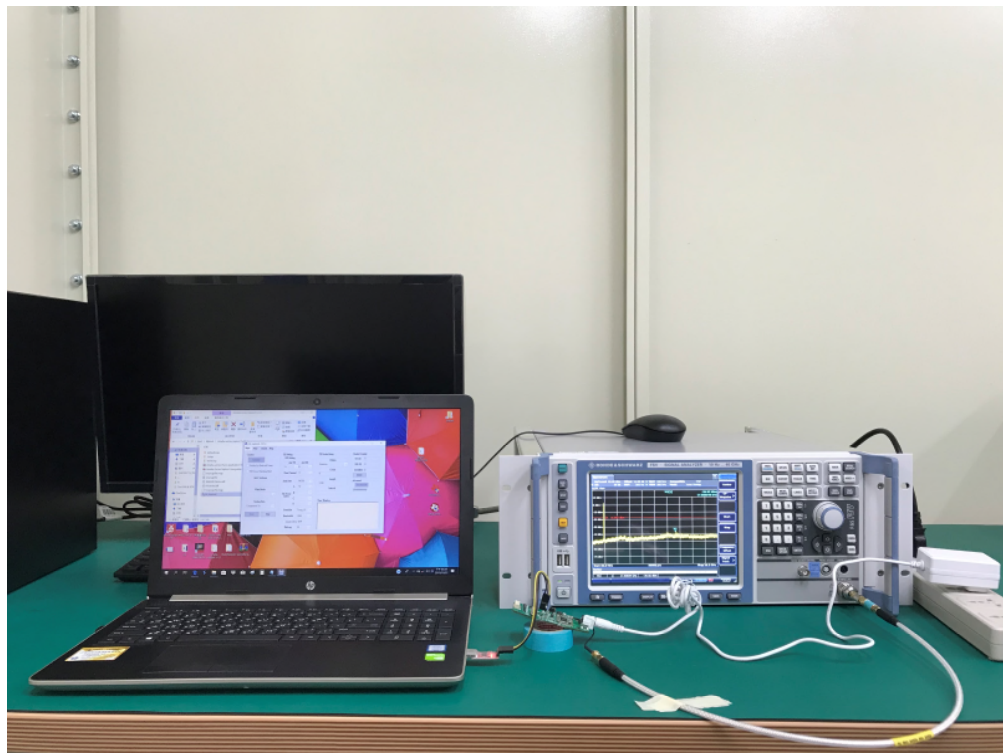

Photograph 7: Set-up for Mains Conducted testing (Back View)



Photograph 8: Set-up for Mains Conducted testing (Front View)



7. List of Tables

Table 1: Applied Standard and Test Levels	5
Table 2: List of Test and Measurement Equipment	7
Table 3: Emission Measurement Uncertainty.....	8
Table 4: Basic Information of EUT	9
Table 5: Technical Specification of EUT	9
Table 6: Table for Parameters of Test Software Setting	11
Table 7: Test result of Peak Output Power (802.11b).....	16
Table 8: Test result of Peak Output Power (802.11g).....	16
Table 9: Test result of Peak Output Power (802.11n HT20).....	16
Table 10: Test result of 6dB Bandwidth (802.11b).....	18
Table 11: Test result of 6dB Bandwidth (802.11g).....	18
Table 12: Test result of 6dB Bandwidth (802.11n HT20).....	18
Table 13: Test result of 99% Bandwidth (802.11b).....	19
Table 14: Test result of 99% Bandwidth (802.11g).....	19
Table 15: Test result of 99% Bandwidth (802.11n HT20).....	19
Table 16: Test result of Power Density (802.11b).....	26
Table 17: Test result of Power Density (802.11g).....	26
Table 18: Test result of Power Density (802.11n HT20).....	26

8. List of Photographs

Photograph 1: Set-up for Spurious Emissions (Front View).....	46
Photograph 2: Set-up for Spurious Emissions (Back View 1).....	46
Photograph 3: Set-up for Spurious Emissions (Back View 2).....	47
Photograph 4: Set-up for Spurious Emissions (Back View 3).....	47
Photograph 5: Set-up for Conducted testing	48
Photograph 6: Set-up for Conducted testing	48
Photograph 7: Set-up for Mains Conducted testing (Back View).....	49
Photograph 8: Set-up for Mains Conducted testing (Front View).....	49