



**FCC 47 CFR PART 15 SUBPART C  
INDUSTRY CANADA RSS-216 ISSUE 2**

**CERTIFICATION TEST REPORT**

**FOR**

**Radiant Wireless Charger**

**MODEL NO: RWC826USBV2**

**FCC ID: YV8-RWC826USBV2**

**IC: 9922A-RWC826USBV2**

**REPORT NUMBER: 12516531-E3V3**

**ISSUE DATE: NOVEMBER 02, 2018**

*Prepared for*  
**PASS & SEYMOUR INC., d/b/a LEGRAND**  
**301 FULLING MILL ROAD SUITE G**  
**MIDDLETOWN, PA 17057, U.S.A.**

*Prepared by*  
**UL VERIFICATION SERVICES INC.**  
**47173 BENICIA STREET**  
**FREMONT, CA 94538, U.S.A.**  
**TEL: (510) 771-1000**  
**FAX: (510) 661-0888**



NVLAP LAB CODE 200065-0

Revision History

<u>Rev.</u>	<u>Issue Date</u>	<u>Revisions</u>	<u>Revised By</u>
V1	10/22/2018	Initial Issue	Chin Pang
V2	10/24/2018	Address TCB's Questions	Chin Pang
V3	11/02/2018	Update Model Number	Chin Pang

## TABLE OF CONTENTS

<b>1. ATTESTATION OF TEST RESULTS .....</b>	<b>5</b>
<b>2. TEST METHODOLOGY .....</b>	<b>6</b>
<b>3. FACILITIES AND ACCREDITATION .....</b>	<b>6</b>
<b>4. CALIBRATION AND UNCERTAINTY .....</b>	<b>6</b>
4.1. MEASURING INSTRUMENT CALIBRATION .....	6
4.2. SAMPLE CALCULATION .....	6
4.3. MEASUREMENT UNCERTAINTY.....	7
<b>5. EQUIPMENT UNDER TEST .....</b>	<b>8</b>
5.1. DESCRIPTION OF EUT .....	8
5.2. MAXIMUM OUTPUT POWER.....	8
5.3. SOFTWARE AND FIRMWARE.....	8
5.4. WORST-CASE CONFIGURATION AND MODE.....	9
5.5. DESCRIPTION OF TEST SETUP.....	10
<b>6. TEST AND MEASUREMENT EQUIPMENT .....</b>	<b>12</b>
<b>7. OCCUPIED BANDWIDTH .....</b>	<b>13</b>
<b>8. RADIATED EMISSION TEST RESULTS.....</b>	<b>16</b>
8.1. LIMITS AND PROCEDURE.....	16
8.2. FCC TX FUNDAMENTAL AND SPURIOUS EMISSIONS FROM 9 kHz TO 30 MHz ..	18
8.2.1. STANDBY CONFIGURATION .....	18
8.2.2. COIL1, OPERATING WITH PHONE .....	19
8.2.3. COIL2, OPERATING WITH PHONE .....	20
8.3. IC / CISPR 11 TX FUNDAMENTAL AND SPURIOUS EMISSIONS FROM 9 kHz TO 30 MHz	21
8.3.1. STANDBY CONFIGURATION .....	21
8.3.2. COIL1, OPERATING WITH PHONE .....	22
8.3.3. COIL2, OPERATING WITH PHONE .....	23
8.4. FCC TX SPURIOUS EMISSION 30 TO 1000 MHz .....	24
8.4.1. STANDBY CONFIGURATION .....	24
8.4.2. COIL 1, OPERATING WITH PHONE .....	26
8.4.3. COIL 2, OPERATING WITH PHONE .....	28
8.5. IC / CISPR 11 TX SPURIOUS EMISSION 30 TO 1000 MHz .....	30
8.5.1. STANDBY CONFIGURATION .....	30
8.5.2. COIL 1, OPERATING WITH PHONE .....	32
8.5.3. COIL 2, OPERATING WITH PHONE .....	34
<b>9. AC POWER LINE CONDUCTED EMISSIONS .....</b>	<b>36</b>
9.1.1. STANDBY MODE POWERED BY AC/DC ADAPTER.....	37
9.1.2. OPERATING MODE WITH PHONE .....	39

---

**10. SETUP PHOTOS .....41**

# 1. ATTESTATION OF TEST RESULTS

**COMPANY NAME:** Pass & Seymour Inc., d/b/a Legrand  
**EUT DESCRIPTION:** Radiant Wireless Charger  
**MODEL NUMBER:** RWC826USBV2  
**SERIAL NUMBER:** 1827136  
**DATE TESTED:** SEPTEMBER 25 – OCTOBER 01 and 18-24, 2018

APPLICABLE STANDARDS	
STANDARD	TEST RESULTS
FCC PART 15 SUBPART C	Complies
INDUSTRY CANADA RSS-216 ISSUE 2	Complies
INDUSTRY CANADA RSS-GEN ISSUE 5	Complies

UL Verification Services Inc. tested the above equipment in accordance with the requirements set forth in the above standards. The test results show that the equipment tested is capable of demonstrating compliance with the requirements as documented in this report.

The results documented in this report apply only to the tested sample, under the conditions and modes of operation as described herein. It is the manufacturer's responsibility to assure that additional production units of this model are manufactured with identical electrical and mechanical components. All samples tested were in good operating condition throughout the entire test program. Measurement Uncertainties are published for informational purposes only and were not taken into account unless noted otherwise.

This document may not be altered or revised in any way unless done so by UL Verification Services Inc. and all revisions are duly noted in the revisions section. Any alteration of this document not carried out by UL Verification Services Inc. will constitute fraud and shall nullify the document. This report must not be used by the client to claim product certification, approval, or endorsement by NVLAP, NIST, any agency of the Federal Government, or any agency of the U.S. government.

Approved & Released For  
UL Verification Services Inc. By:

Prepared By:

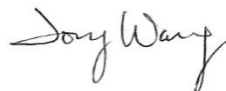

CHIN PANG  
SENIOR TEST ENGINEER  
UL VERIFICATION SERVICES INC.

TONY WANG  
LAB ENGINEER  
UL VERIFICATION SERVICES INC.

## 2. TEST METHODOLOGY

The tests documented in this report were performed in accordance with ANSI C63.10-2013, FCC CFR 47 Part 2, and FCC CFR 47 Part 15, RSS-GEN Issue 5 and RSS-216 Issue 2 January 2016.

## 3. FACILITIES AND ACCREDITATION

The test sites and measurement facilities used to collect data are located at 47173 and 47266 Benicia Street, Fremont, California, USA. Line conducted emissions are measured only at the 47173 address. The following table identifies which facilities were utilized for radiated emission measurements documented in this report. Specific facilities are also identified in the test results sections.

47173 Benicia Street	47266 Benicia Street
<input checked="" type="checkbox"/> Chamber A (IC:2324B-1)	<input type="checkbox"/> Chamber D (IC: 22541-1)
<input type="checkbox"/> Chamber B (IC:2324B-2)	<input type="checkbox"/> Chamber E (IC: 22541-2)
<input checked="" type="checkbox"/> Chamber C (IC:2324B-3)	<input type="checkbox"/> Chamber F (IC: 22541-3)
	<input type="checkbox"/> Chamber G (IC: 22541-4)
	<input type="checkbox"/> Chamber H (IC: 22541-5)

The above test sites and facilities are covered under FCC Test Firm Registration # 208313.

UL Verification Services Inc. is accredited by NVLAP, Laboratory Code 200065-0. The full scope of accreditation can be viewed at [NVLAP Lab Search](#).

## 4. CALIBRATION AND UNCERTAINTY

### 4.1. MEASURING INSTRUMENT CALIBRATION

The measuring equipment utilized to perform the tests documented in this report has been calibrated in accordance with the manufacturer's recommendations, and is traceable to recognized national standards.

### 4.2. SAMPLE CALCULATION

Where relevant, the following sample calculation is provided:

$$\begin{aligned} \text{Field Strength (dBuV/m)} &= \text{Measured Voltage (dBuV)} + \text{Antenna Factor (dB/m)} + \\ &\text{Cable Loss (dB)} - \text{Preamp Gain (dB)} \\ 36.5 \text{ dBuV} + 18.7 \text{ dB/m} + 0.6 \text{ dB} - 26.9 \text{ dB} &= 28.9 \text{ dBuV/m} \end{aligned}$$

### 4.3. MEASUREMENT UNCERTAINTY

Where relevant, the following measurement uncertainty levels have been estimated for tests performed on the apparatus:

PARAMETER	UNCERTAINTY
Conducted Disturbance, 9KHz to 0.15 MHz	3.84 dB
Conducted Disturbance, 0.15 to 30 MHz	3.65 dB
Radiated Disturbance, 9KHz to 30 MHz	3.15 dB
Radiated Disturbance, 30 to 1000 MHz	5.36 dB
Radiated Disturbance, 1000 to 18000 MHz	4.32 dB
Radiated Disturbance, 18000 to 26000 MHz	4.45 dB
Radiated Disturbance, 26000 to 40000 MHz	5.24 dB

Uncertainty figures are valid to a confidence level of 95%.

## 5. EQUIPMENT UNDER TEST

### 5.1. DESCRIPTION OF EUT

The EUT is a wireless charger which has a multiple inductive charging coil to charge phone. The charging frequency is 110KHz – 148KHz, and the maximum power consumption is 5 W in charging status.

Config	Mode	Descriptions
1	Standby	EUT alone powered by 115Vac
2	Operating	EUT and phone powered by 115Vac

Note that the EUT was tested as standby and operation modes.

### 5.2. MAXIMUM OUTPUT POWER

The transmitter has maximum peak radiated electric and magnetic field strength as follows:

Coil	Fundamental Frequency (KHz)	Mode	E field (300m distance) FCC (dBuV/m)	H field (3m distance) IC (dBuA/m)
Coil1/Coil2	145.4	Standby	5.92	35.56
Coil1	115.0	Operating	-3.43	24.04
Coil2	145.4	Operating	4.58	27.50

### 5.3. SOFTWARE AND FIRMWARE

The firmware version is "Legrand\_TXPad\_v8017.0003.0011\_OTP".



## 5.4. WORST-CASE CONFIGURATION AND MODE

The EUT is a wireless charger enclosed in plastic case with two different coils, Coil1 and Coil2. Both Coil1 and Coil2 were investigated with phone on below 30MHz and 30-1GHz .

Config	Mode	Descriptions
1	Standby	EUT Alone powered by US115Vac
2	Operating	EUT and Phone powered by US115Vac

For all radiated emissions tests were investigated during the charging process, the phone actively indicates the status of the charging process. Device being charged was at a state of 20 – 50% charged.

For below 30MHz testing, investigation was done on three antenna orientations: RX antenna Face-on, Face-off and horizontal (parallel to ground). The worst-case configurations were determined on RX antenna Face-on and Face-off; therefore, all final tests were performed using these two orientations.

Although these tests were performed other than open area test site, adequate comparison measurements were confirmed against 300 m open area test site. Therefore sufficient tests were made to demonstrate that the alternative site produces results that correlate with the ones of tests made in an open field based on KDB 414788 D01.

## 5.5. DESCRIPTION OF TEST SETUP

### SUPPORT EQUIPMENT & PERIPHERALS

SUPPORT EQUIPMENT & PERIPHERALS LIST				
Description	Manufacturer	Model	Serial Number	FCC ID
Phone	Samsung	Galaxy S7	SM-G930U	A3LSMG930US

### I/O CABLES

I/O Cable List						
Cable No	Port	# of identical ports	Connector Type	Cable Type	Cable Length (m)	Remarks
1	AC	1	AC	Un-shielded	2	N/A

### TEST SETUP

**CONFIGURATION 1: STANDBY MODE**

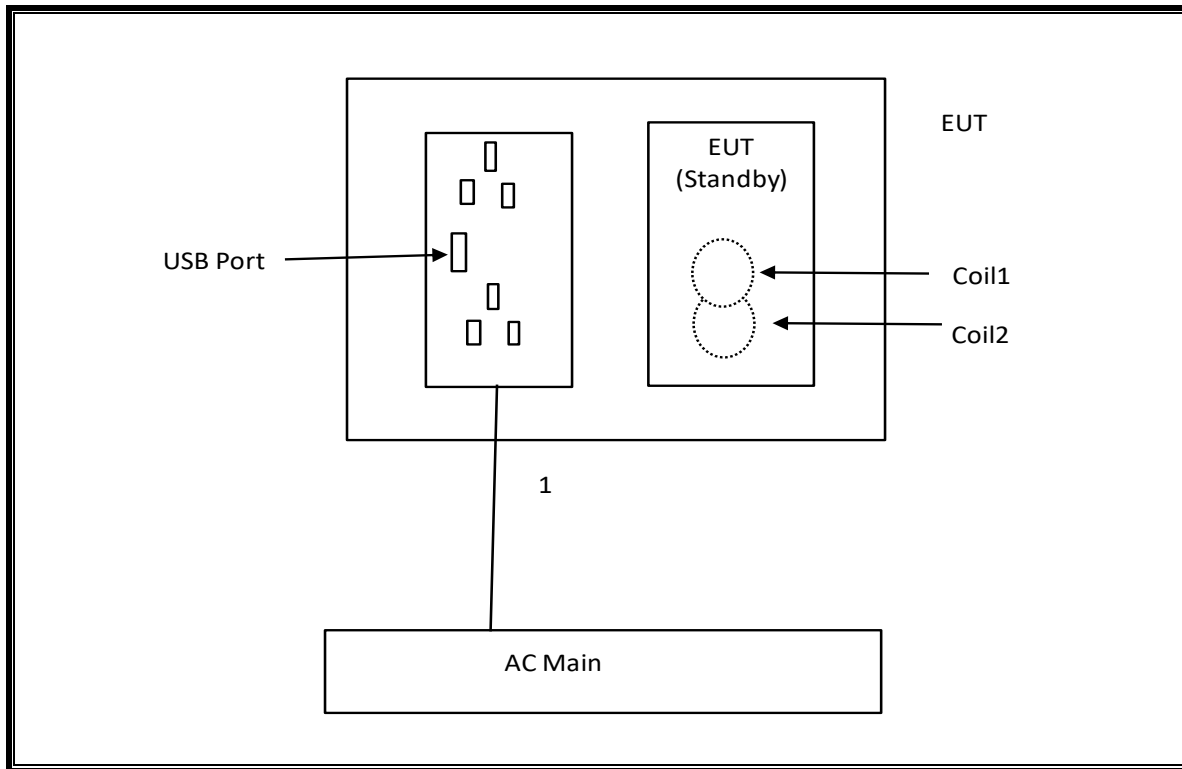

**CONFIGURATION 2: OPERATING MODE WITH PHONE**

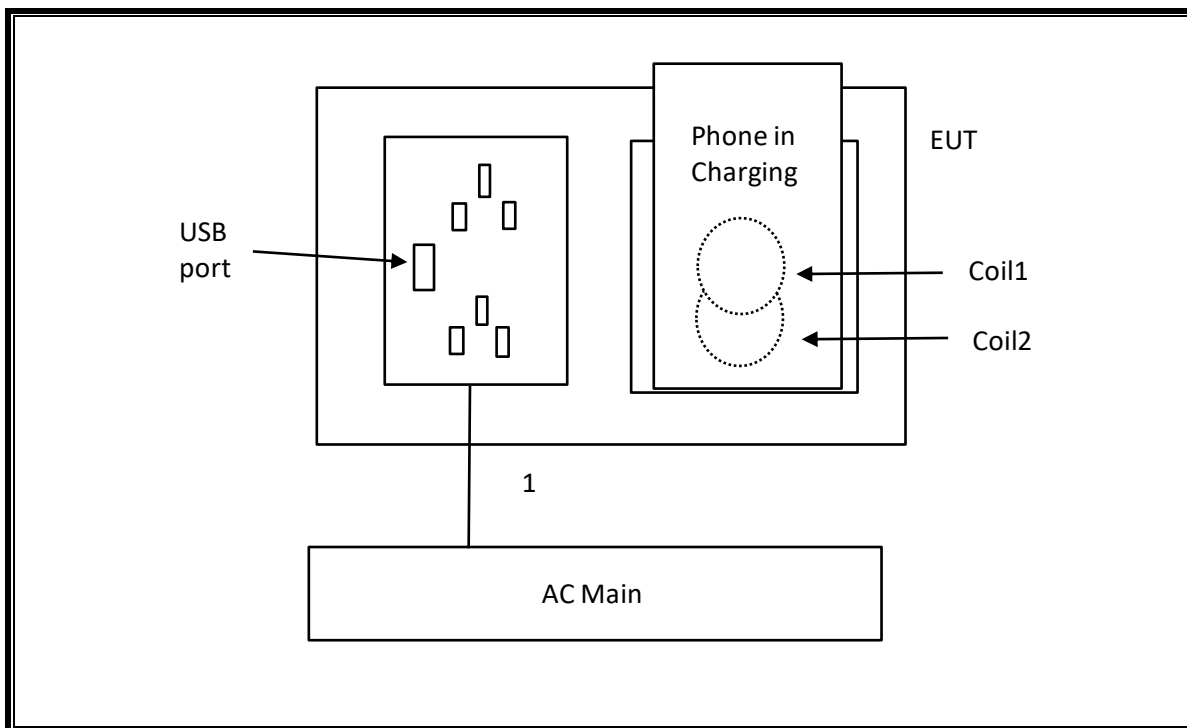

## 6. TEST AND MEASUREMENT EQUIPMENT

The following test and measurement equipment was utilized for the tests documented in this report:

TEST EQUIPMENT LIST				
Description	Manufacturer	Model	ID Num	Cal Due
Antenna, Broadband Hybrid, 30MHz to 2000MHz	Sunol Sciences Corp.	JB1	T130	10/16/2018
Amplifier, 10KHz to 1GHz, 32dB	Sonoma Instrument Co.	310N	T15	08/15/2019
Spectrum Analyzer, PXA 3Hz to 44GHz	Keysight	N9030A	T1466	04/16/2019
Antenna, Active Loop 9KHz to 30MHz	EMCO	6502	T35	12/15/2018
Antenna, Broadband Hybrid, 30MHz to 2000MHz	Sunol Sciences	JB1	T243	11/2/2018
Antenna, Active Loop 9kHz-30MHz	ETS-Lindgren	6502	T1683	02/21/2019
Amplifier, 10KHz to 1GHz, 32dB	Sonoma	310N	T300	12/11/2018
Spectrum Analyzer, PXA 3Hz to 44GHz	Keysight	N9030A	T1450	02/05/2019
Sniffer Probes	Electro Metrics	EM-6992	N/A	N/A
AC Line Conducted				
EMI Test Receiver 9KHz-7GHz	Rohde & Schwarz	ESCI7	T1436	01/25/2019
LISN for Conducted Emissions CISPR-16	Fischer	50/250-25-2-01	T1310	06/15/2019

Test Software List			
Description	Manufacturer	Model	Version
Radiated Software	UL	UL EMC	Ver. 9.5, April 26, 2016

## **7. OCCUPIED BANDWIDTH**

### **TEST PROCEDURE**

The transmitter output is connected to the spectrum analyzer. The RBW is set to 200Hz. The VBW is set to 3 times the RBW. The sweep time is coupled. The spectrum analyzer internal 99% bandwidth function is utilized.

Note: Because the measured signal is CW-like, adjusting the RBW per C63.10 would not be practical since measured bandwidth will always follow the RBW and the result will be approximately twice the RBW.

### **EUT SETUP**

1. Charger in standby mode
2. Charger in operating mode on Coil 1 and 2.

### **RESULTS**

**STANDBY MODE**

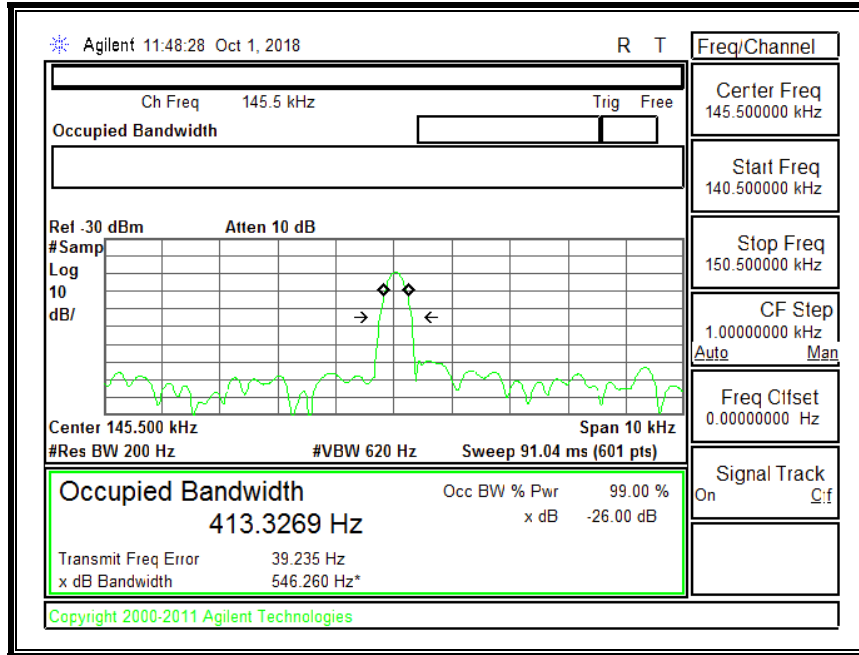

**OPERATING MODE, COIL1**

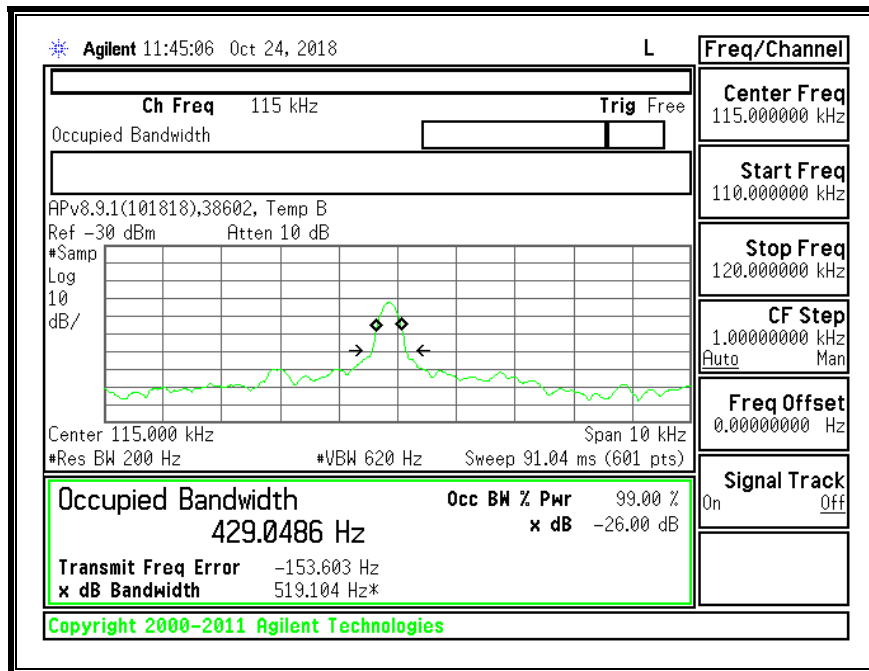

**OPERATING MODE, COIL2**

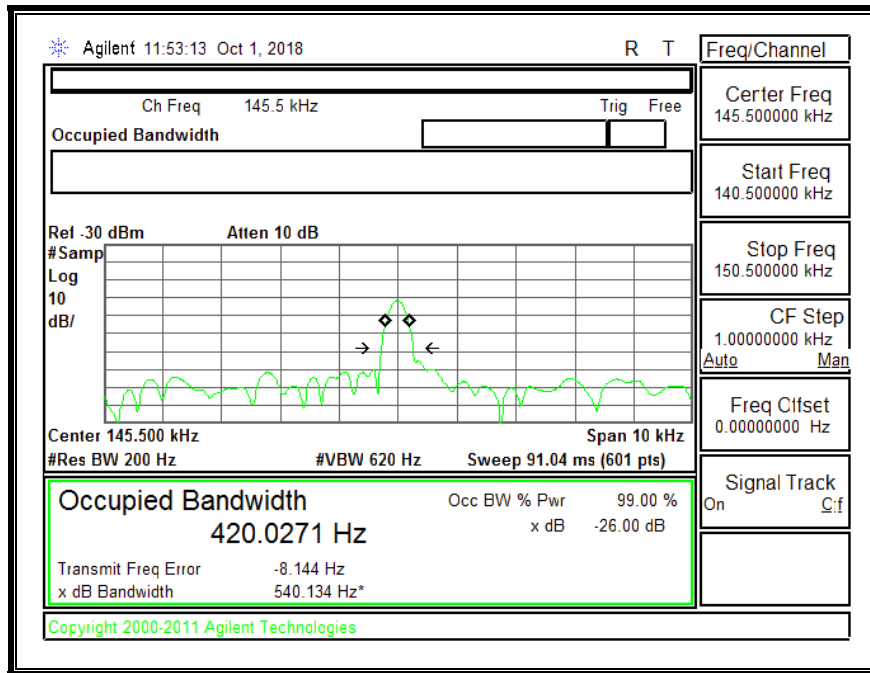

## 8. RADIATED EMISSION TEST RESULTS

### 8.1. LIMITS AND PROCEDURE

#### LIMITS

FCC §15.209 (a)

ICES-001 Section 6.2, IC RSS-216 6.2.2, and IC RSS-GEN Sections 8.9 and 8.10.

Frequency (MHz)	Field Strength (microvolts/meter)	Measurement Distance (m)
0.009–0.490	2400/F(kHz)	300
0.490–1.705	24000/F(kHz)	30
1.705–30.0	30	30
30–88	100	3
88 to 216	150	3
216 to 960	200	3
Above 960 MHz	500	3

Note: The lower limit shall apply at the transition frequency.

#### CISPR 11:04

Electromagnetic radiation disturbance limits for class B group 2 equipment measured on a test site

Frequency Range (MHz)	Magnetic Field Strength Limit Class B Group 2 @ 3m Distance (dBuA/m)
	Quasi-peak
0.009 - 0.070	69
0.070 - 0.1485	69
	Decreasing Linearly with Logarithm of Frequency to 39
0.1485 - 4.0	39
	Decreasing Linearly with Logarithm of Frequency to 3
4.0 - 30	3

The limits of this table apply to induction cooking appliances intended for commercial use and those for domestic use with a diagonal diameter of more than 1.6m.  
 The measurements are performed at 3m distance with a 0.6 m loop antenna as described in 4.2.1 of CISPR 16-1-4.  
 The antenna should be vertically installed, with the lower edge of the loop at 1m height above the floor.



Frequency Range (MHz)	Electric Field Strength Limit Class B Group 2 @ 3m Distance (dBuV/m)	
	Quasi-peak	Average
30 – 80,872	40	35
80,872 – 81,848	60	55
81,848 – 134,786	40	35
134,786 – 136,414	60	55
136,414 – 230	40	35
230 – 1 000	47	42

## **RESULTS**

The EUT belongs to RSS-216, Type 3 (Category I Radio Apparatus) firstly.

## 8.2. FCC TX FUNDAMENTAL AND SPURIOUS EMISSIONS FROM 9 kHz TO 30 MHz

### 8.2.1. STANDBY CONFIGURATION

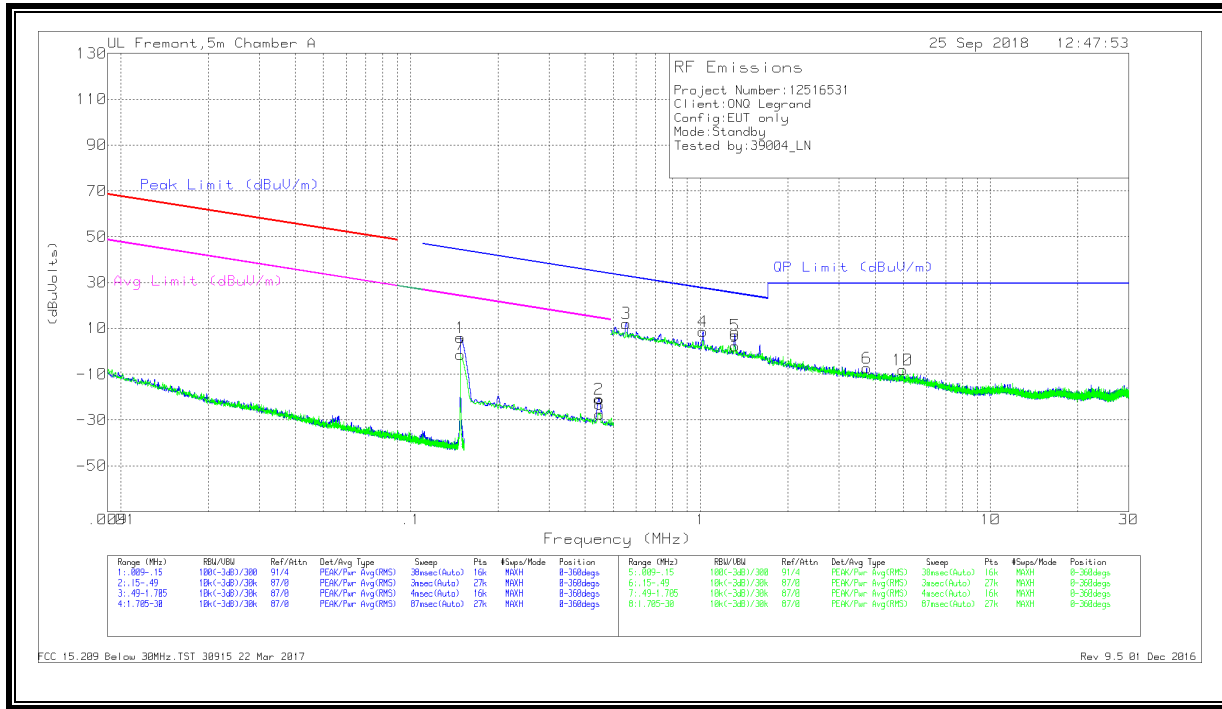

### DATA

Marker	Frequency (MHz)	Meter Reading (dBuV)	Det	Loop Antenna (dB/m)	Cbl (dB)	Dist Corr 300m	Corrected Reading (dBuVolts)	Peak Limit (dBuV/m)	Margin (dB)	Avg Limit (dBuV/m)	Margin (dB)	Azimuth (Degs)
7	.14543	67.24	Pk	11.1	.1	-80	-1.56	44.19	-45.75	24.19	-25.75	0-360
1	.14546	74.72	Pk	11.1	.1	-80	5.92	44.19	-38.27	24.19	-18.27	0-360
2	.4459	47.93	Pk	11	.1	-80	-20.97	34.62	-55.59	14.62	-35.59	0-360
8	.44767	41.33	Pk	11	.1	-80	-27.57	34.59	-62.16	14.59	-42.16	0-360

### Pk - Peak detector

Marker	Frequency (MHz)	Meter Reading (dBuV)	Det	Loop Antenna (dB/m)	Cbl (dB)	Dist Corr 30m	Corrected Reading (dBuVolts)	QP Limit (dBuV/m)	Margin (dB)	Azimuth (Degs)
3	.5549	41	Pk	11.1	.1	-40	12.2	32.72	-20.52	0-360
4	1.01961	37.09	Pk	11.3	.2	-40	8.59	27.45	-18.86	0-360
9	1.31171	30.85	Pk	11.3	.2	-40	2.35	25.27	-22.92	0-360
5	1.31186	35.52	Pk	11.3	.2	-40	7.02	25.27	-18.25	0-360
6	3.73864	21.12	Pk	11.3	.3	-40	-7.28	29.5	-36.78	0-360
10	4.9821	20.38	Pk	11.2	.3	-40	-8.12	29.5	-37.62	0-360

### Pk - Peak detector

FCC 15.209 Below 30MHz.TST 30915 22 Mar 2017  
 Rev 9.5 01 Dec 2016

### 8.2.2. COIL1, OPERATING WITH PHONE

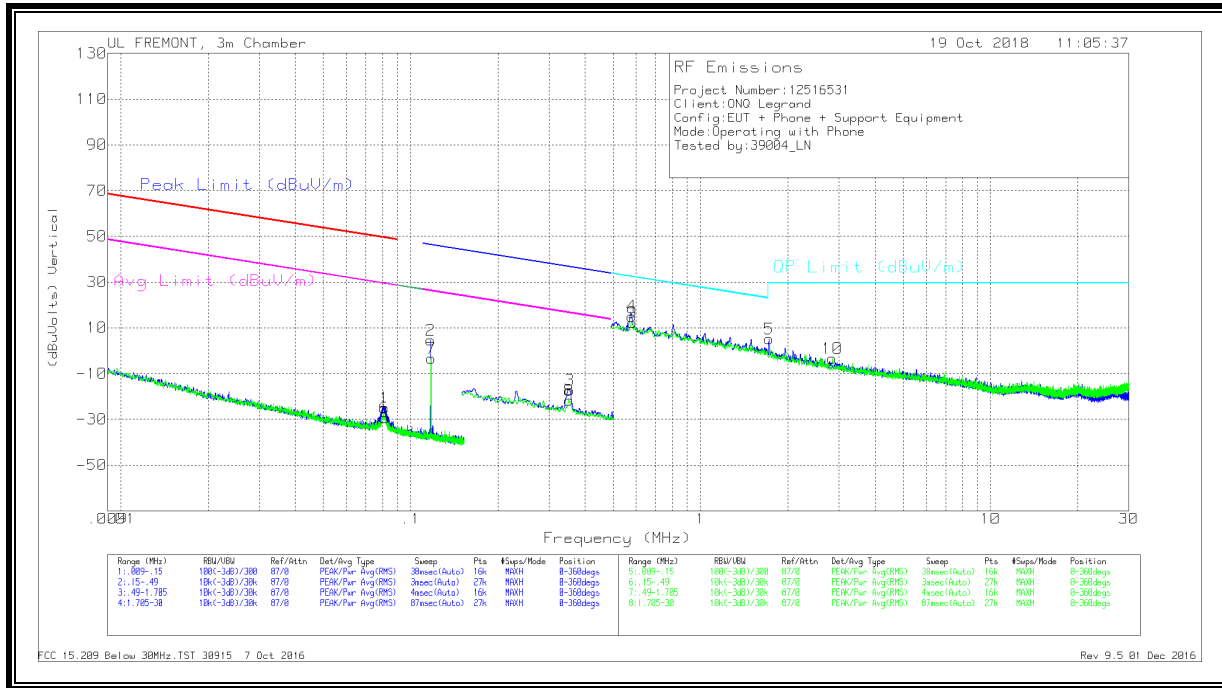

### DATA

Marker	Frequency (MHz)	Meter Reading (dBuV)	Det	Loop Antenna (dB/m)	Cbl (dB)	Dist Corr 300m	Corrected Reading (dBuVolts)	Peak Limit (dBuV/m)	Margin (dB)	Avg Limit (dBuV/m)	Margin (dB)	Azimuth (Degs)
1	.08127	41.71	Pk	11.9	1.4	-80	-24.99	49.39	-74.38	29.39	-54.38	0-360
6	.0813	37.41	Pk	11.9	1.4	-80	-29.29	49.38	-78.67	29.38	-58.67	0-360
2	.1155	71.38	Pk	11.8	1.4	-80	4.58	46.26	-41.68	26.26	-21.68	0-360
7	.1155	63.53	Pk	11.8	1.4	-80	-3.27	46.23	-49.5	26.23	-29.5	0-360
8	.35169	45.02	Pk	11.7	1.5	-80	-21.78	36.69	-58.47	16.69	-38.47	0-360
3	.35347	49.59	Pk	11.7	1.5	-80	-17.21	36.64	-53.85	16.64	-33.85	0-360

### Pk - Peak detector

Marker	Frequency (MHz)	Meter Reading (dBuV)	Det	Loop Antenna (dB/m)	Cbl (dB)	Dist Corr 30m	Corrected Reading (dBuVolts)	QP Limit (dBuV/m)	Margin (dB)	Azimuth (Degs)
4	.57869	41.92	Pk	11.7	1.5	-40	15.12	32.36	-17.24	0-360
9	.58052	39.02	Pk	11.7	1.5	-40	12.22	32.33	-20.11	0-360
5	1.72177	31.76	Pk	11.9	1.5	-40	5.16	29.5	-24.34	0-360
10	2.84522	23.27	Pk	11.8	1.5	-40	-3.43	29.5	-32.93	0-360

### Pk - Peak detector

FCC 15.209 Below 30MHz.TST 30915 7 Oct 2016  
 Rev 9.5 01 Dec 2016

### 8.2.3. COIL2, OPERATING WITH PHONE

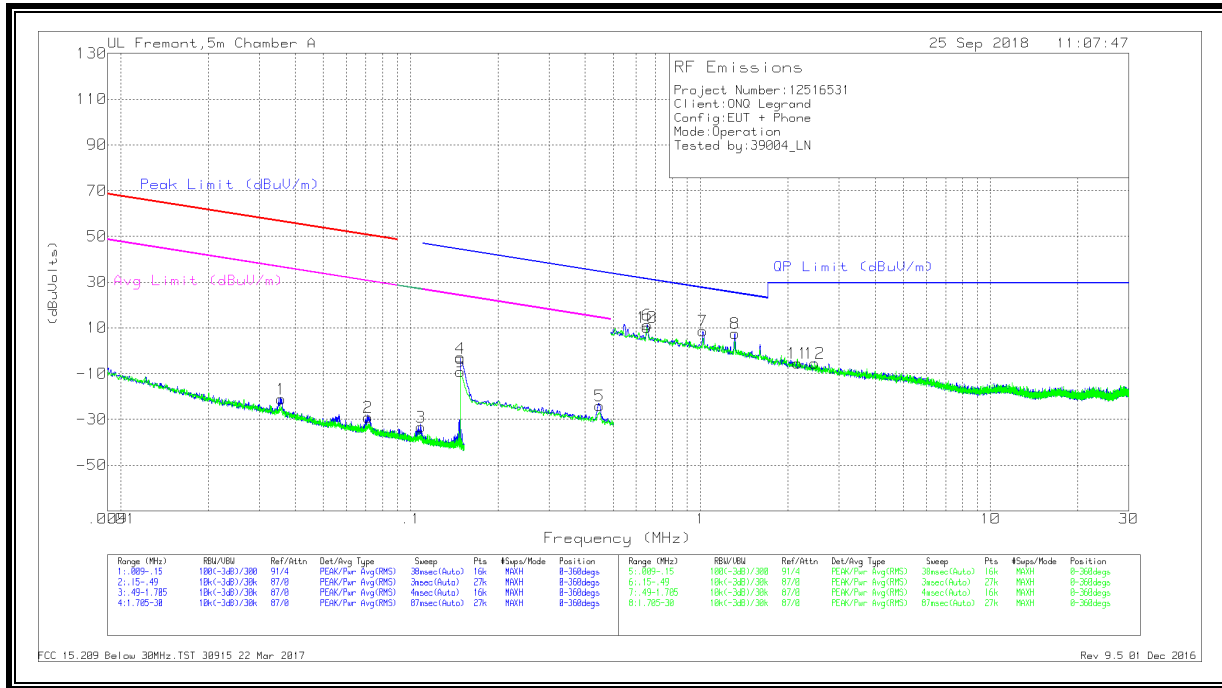

#### DATA

Marker	Frequency (MHz)	Meter Reading (dBuV)	Det	Loop Antenna (dB/m)	Cbl (dB)	Dist Corr 300m	Corrected Reading (dBuVolts)	Peak Limit (dBuV/m)	Margin (dB)	Avg Limit (dBuV/m)	Margin (dB)	Azimuth (Degs)
1	.03581	45.59	Pk	13.2	.1	-80	-21.11	56.5	-77.61	36.5	-57.61	0-360
2	.07129	39.23	Pk	11.5	.1	-80	-29.17	50.52	-79.69	30.52	-59.69	0-360
3	.10857	35.31	Pk	11.1	.1	-80	-33.49	-	-	-	-	0-360
9	.1453	59.66	Pk	11.1	.1	-80	-9.14	44.2	-53.34	24.2	-33.34	0-360
4	.1453	65.37	Pk	11.1	.1	-80	-3.43	44.2	-47.63	24.2	-27.63	0-360
5	.44922	44.91	Pk	11	.1	-80	-23.99	34.56	-58.55	14.56	-38.55	0-360

#### Pk - Peak detector

7	Frequency (MHz)	Meter Reading (dBuV)	Det	Loop Antenna (dB/m)	Cbl (dB)	Dist Corr 30m	Corrected Reading (dBuVolts)	QP Limit (dBuV/m)	Margin (dB)	Azimuth (Degs)
10	.65275	39.09	Pk	11	.1	-40	10.19	31.32	-21.13	0-360
6	.65465	40.1	Pk	11	.1	-40	11.2	31.29	-20.09	0-360
7	1.01904	37.11	Pk	11.3	.2	-40	8.61	27.46	-18.85	0-360
8	1.31251	35.94	Pk	11.3	.2	-40	7.44	25.27	-17.83	0-360
11	2.15616	22.9	PK	11.4	.2	-40	-5.5	29.5	-35	0-360
12	2.47685	22.88	Pk	11.4	.2	-40	-5.52	29.5	-35.02	0-360

#### Pk - Peak detector

FCC 15.209 Below 30MHz.TST 30915 22 Mar 2017  
 Rev 9.5 01 Dec 2016

### 8.3. IC / CISPR 11 TX FUNDAMENTAL AND SPURIOUS EMISSIONS FROM 9 kHz TO 30 MHz

#### 8.3.1. STANDBY CONFIGURATION

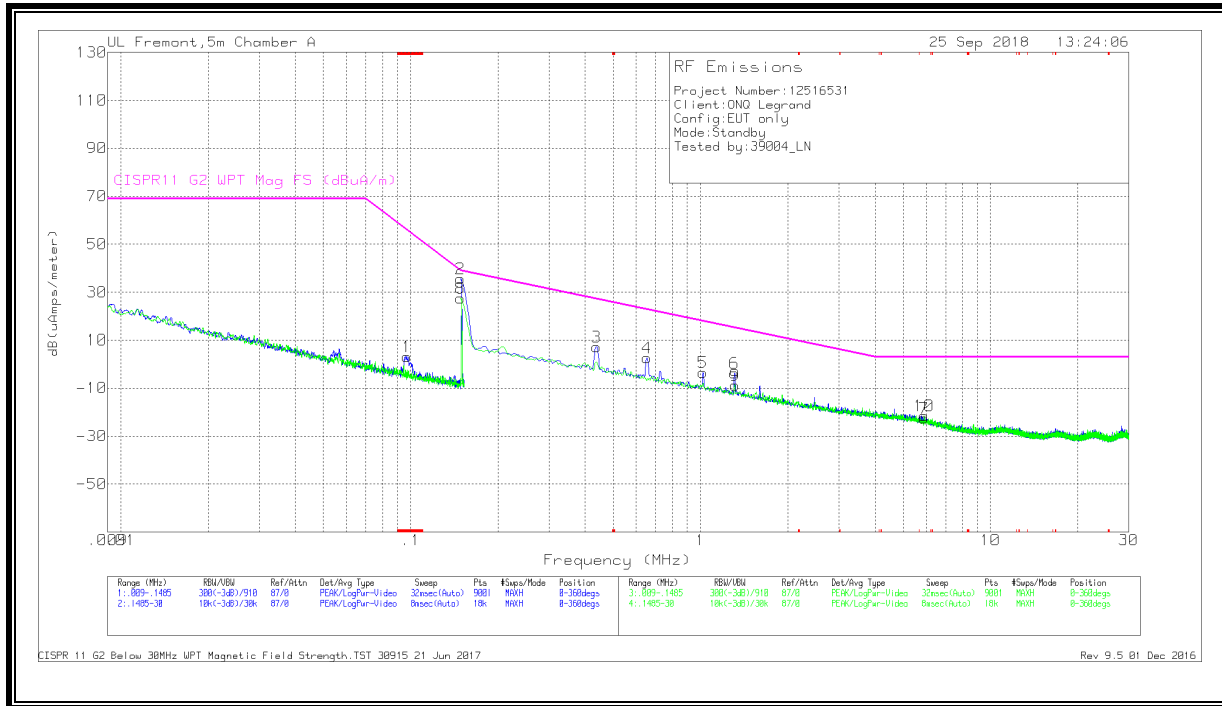

#### DATA

Marker	Frequency (MHz)	Meter Reading (dBuV)	Det	Loop Antenna (dB/m)	Cbl (dB)	Corrected Reading dB(uAmps/meter)	CISPR11 G2 WPT Mag FS (dBuA/m)	Margin (dB)	Azimuth (Degs)
1	*.09702	42.91	Pk	-39.9	.1	3.11	55.98	-52.87	0-360
2	.1455	75.56	Pk	-40.1	.1	35.56	39	-3.44	0-360
8	.1455	67.45	Pk	-40.1	.1	27.45	39	-11.55	0-360
3	.43699	47.65	Pk	-40.5	.1	7.25	27.2	-19.95	0-360
4	.65253	42.92	Pk	-40.4	.1	2.62	22.82	-20.2	0-360
5	1.01729	36.59	Pk	-40.2	.2	-3.41	17.97	-21.38	0-360
6	1.30993	36.34	Pk	-40.2	.2	-3.66	15.2	-18.86	0-360
9	1.31242	31.21	Pk	-40.2	.2	-8.79	15.18	-23.97	0-360
7	5.8885	17.37	Pk	-40.3	.4	-22.53	3	-25.53	0-360
10	5.90508	18.45	Pk	-40.3	.4	-21.45	3	-24.45	0-360

\* - indicates frequency in CFR47 Pt 15 / IC RSS-Restricted Band

Pk - Peak detector

CISPR 11 G2 Below 30MHz WPT Magnetic Field Strength.TST 30915 21 Jun 2017  
 Rev 9.5 01 Dec

### 8.3.2. COIL1, OPERATING WITH PHONE

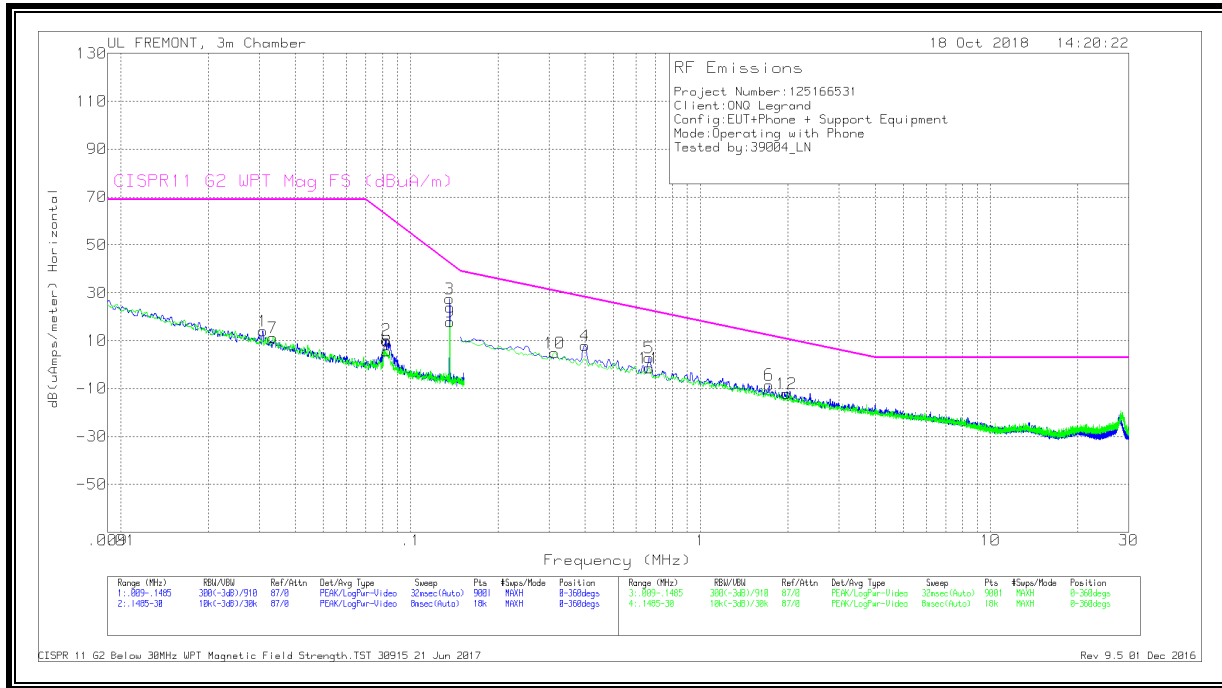

#### DATA

Marker	Frequency (MHz)	Meter Reading (dBuV)	Det	Loop Antenna (dB/m)	Cbl (dB)	Corrected Reading dB(uAmps/meter)	CISPR11 G2 WPT Mag FS (dBuA/m)	Margin (dB)	Azimuth (Degs)
1	.0309	49.22	Pk	-36.6	1.4	14.02	69	-54.98	0-360
7	.03346	46.72	Pk	-36.9	1.4	11.22	69	-57.78	0-360
2	.08233	48.46	Pk	-39.5	1.4	10.36	62.53	-52.17	0-360
8	.08277	43.82	Pk	-39.5	1.4	5.72	62.32	-56.6	0-360
3	.1156	66.2	Pk	-40.1	1.4	27.5	42.45	-14.95	0-360
9	.1156	56.48	Pk	-40.1	1.4	17.78	42.35	-24.57	0-360
10	.31347	43.84	Pk	-40.5	1.5	4.84	30.83	-25.99	0-360
4	.39886	46.97	Pk	-40.6	1.5	7.87	28.2	-20.33	0-360
5	.66414	41.74	Pk	-40.4	1.5	2.84	22.63	-19.79	0-360
11	.66414	37.47	Pk	-40.4	1.5	-1.43	22.63	-24.06	0-360
6	1.7236	30.18	Pk	-40.1	1.5	-8.42	12.2	-20.62	0-360
12	1.98391	26.54	Pk	-40.1	1.5	-12.06	10.66	-22.72	0-360

Pk - Peak detector

CISPR 11 G2 Below 30MHz WPT Magnetic Field Strength.TST 30915 21 Jun 2017  
 Rev 9.5 01 Dec 2016

### 8.3.3. COIL2, OPERATING WITH PHONE

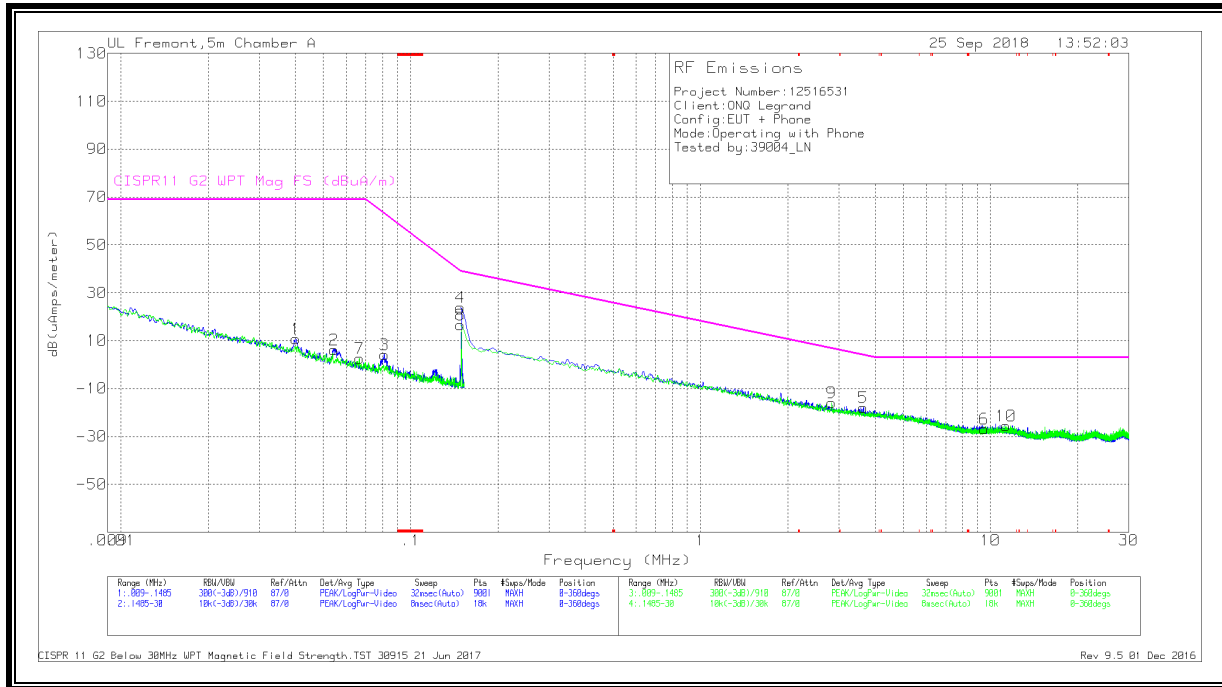

### DATA

Marker	Frequency (MHz)	Meter Reading (dBuV)	Det	Loop Antenna (dB/m)	Cbl (dB)	Corrected Reading dB(uAmps/meter)	CISPR11 G2 WPT Mag FS (dBuA/m)	Margin (dB)	Azimuth (Degs)
1	.04013	48.27	Pk	-37.7	.1	10.67	69	-58.33	0-360
2	.05434	44.8	Pk	-38.8	.1	6.1	69	-62.9	0-360
7	.06654	41.82	Pk	-39.2	.1	2.72	69	-66.28	0-360
3	.08114	43.45	Pk	-39.5	.1	4.05	63.11	-59.06	0-360
4	.1455	64.04	Pk	-40.1	.1	24.04	39	-14.96	0-360
8	.1455	56.55	Pk	-40.1	.1	16.55	39	-22.45	0-360
9	2.8328	23.91	Pk	-40.1	.3	-15.89	6.77	-22.66	0-360
5	3.64605	21.83	Pk	-40	.3	-17.87	4.01	-21.88	0-360
6	9.49962	13.53	Pk	-40.8	.5	-26.77	3	-29.77	0-360
10	11.33254	14.62	Pk	-40.6	.5	-25.48	3	-28.48	0-360

Pk - Peak detector

CISPR 11 G2 Below 30MHz WPT Magnetic Field Strength.TST 30915 21 Jun 2017  
 Rev 9.5 01 Dec 2016

## 8.4. FCC TX SPURIOUS EMISSION 30 TO 1000 MHz

### 8.4.1. STANDBY CONFIGURATION

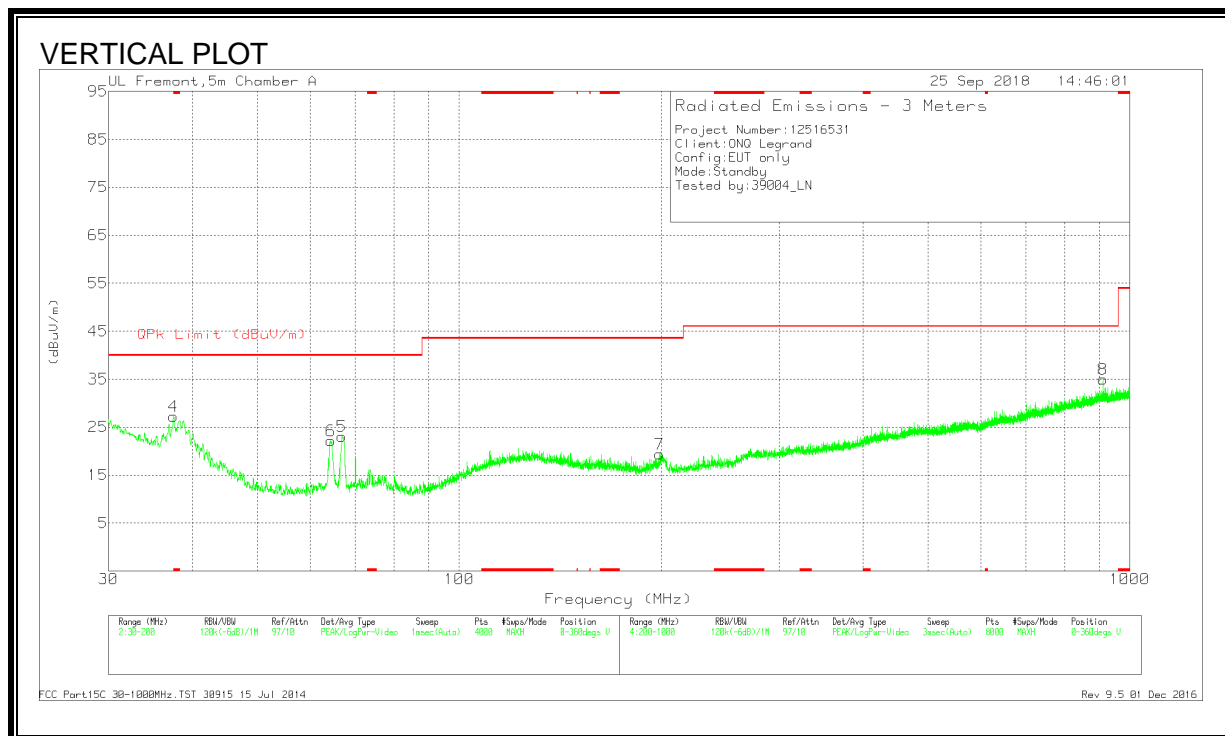
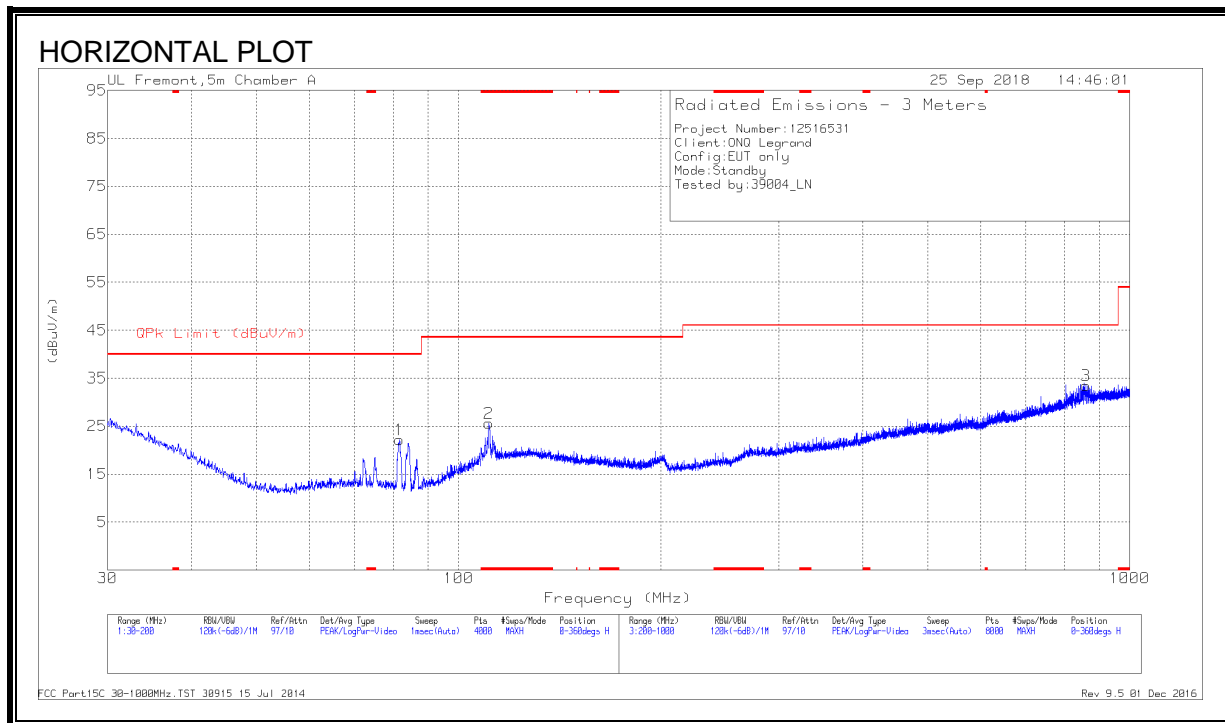



**DATA**

Marker	Frequency (MHz)	Meter Reading (dBuV)	Det	AF T130 (dB/m)	Amp/Cb l (dB/m)	Corrected Reading (dBuV/m)	QPk Limit (dBuV/m)	Margin (dB)	Azimuth (Degs)	Height (cm)	Polarity
2	* 110.984	35.1	Pk	16.8	-26.3	25.6	43.52	-17.92	0-360	400	H
4	* 37.5244	34.79	Pk	19.7	-27.2	27.29	40	-12.71	0-360	100	V
6	64.3489	36.96	Pk	12	-26.8	22.16	40	-17.84	0-360	100	V
5	66.857	37.74	Pk	12.1	-26.8	23.04	40	-16.96	0-360	100	V
1	81.6509	37.34	Pk	11.4	-26.6	22.14	40	-17.86	0-360	200	H
7	198.9812	28.22	Pk	16.5	-25.3	19.42	43.52	-24.1	0-360	100	V
3	859.5857	30.99	Pk	25.8	-23.3	33.49	46.02	-12.53	0-360	101	H
8	911.8925	31.36	Pk	26.6	-23	34.96	46.02	-11.06	0-360	101	V

\* - indicates frequency in CFR47 Pt 15 / IC RSS-Restricted Band

Pk - Peak detector

FCC Part15C 30-1000MHz.TST 30915 15 Jul 2014

Rev 9.5 01 Dec 2016

**8.4.2. COIL 1, OPERATING WITH PHONE**

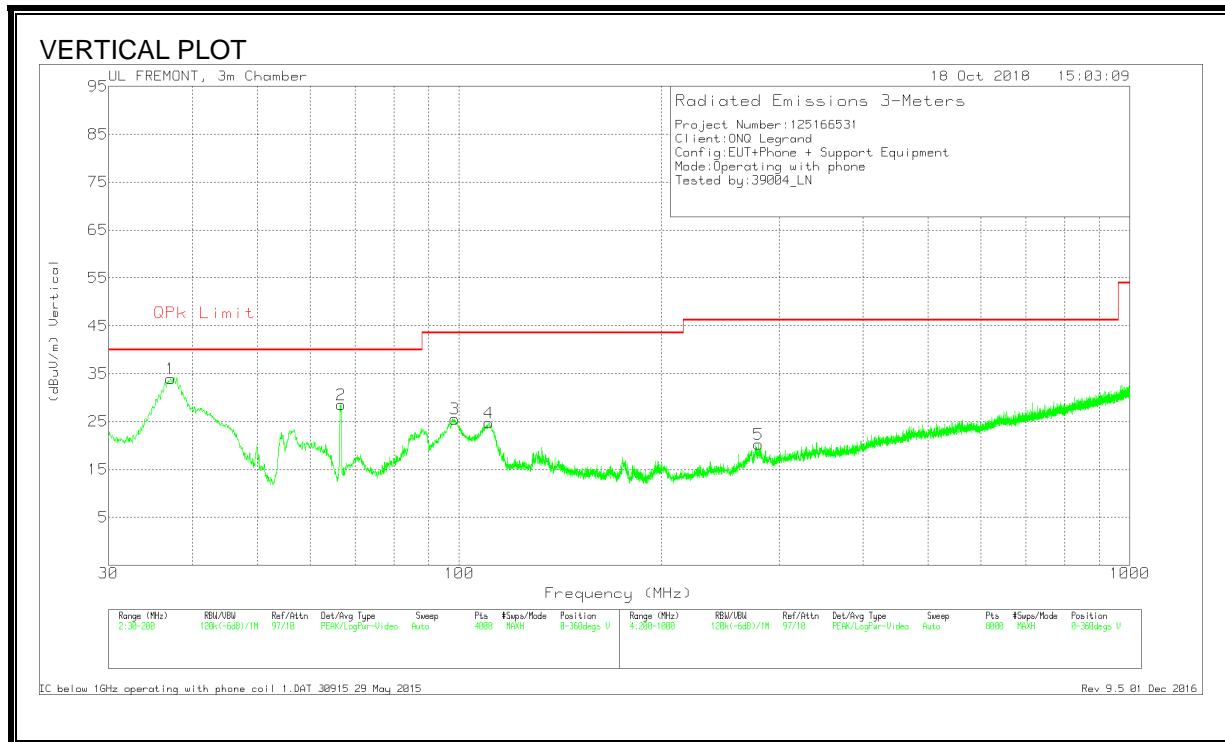
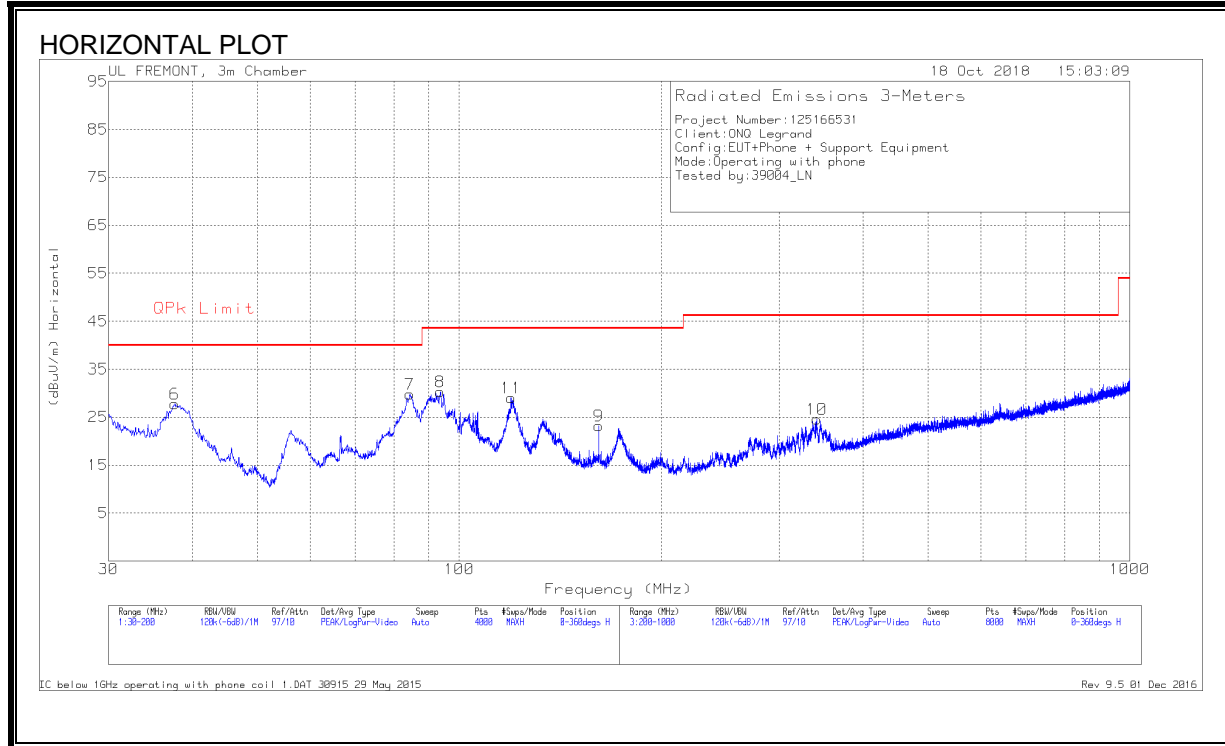

DATA

Marker	Frequency (MHz)	Meter Reading (dBuV)	Det	AF T243 (dB/m)	Amp/Cbl (dB/m)	Corrected Reading (dBuV/m)	QPk Limit	Margin (dB)	Azimuth (Degs)	Height (cm)	Polarity
1	37.1418	44.93	Pk	20	-31	33.93	40	-6.07	0-360	100	V
6	37.652	39.21	Pk	19.6	-31	27.81	40	-12.19	0-360	400	H
2	66.6445	47.1	Pk	12	-30.6	28.5	40	-11.5	0-360	100	V
7	84.4566	49.03	Pk	11.3	-30.5	29.83	40	-10.17	0-360	300	H
8	93.7452	48.15	Pk	12.4	-30.3	30.25	43.52	-13.27	0-360	300	H
3	98.4427	42.04	Pk	13.8	-30.3	25.54	43.52	-17.98	0-360	100	V
4	110.7284	38.15	Pk	16.8	-30.2	24.75	43.52	-18.77	0-360	100	V
11	119.4644	41.23	Pk	17.9	-30.1	29.03	43.52	-14.49	0-360	200	H
9	161.529	36.79	Pk	16.1	-29.7	23.19	43.52	-20.33	0-360	200	H
5	279.7104	31.66	Pk	17.5	-28.9	20.26	46.2	-25.94	0-360	100	V
10	341.5184	35.08	Pk	18	-28.5	24.58	46.2	-21.62	0-360	100	H

Pk - Peak detector

IC below 1GHz operating with phone coil 1.DAT 30915 29 May 2015

Rev 9.5 01 Dec 2016

**8.4.3. COIL 2, OPERATING WITH PHONE**

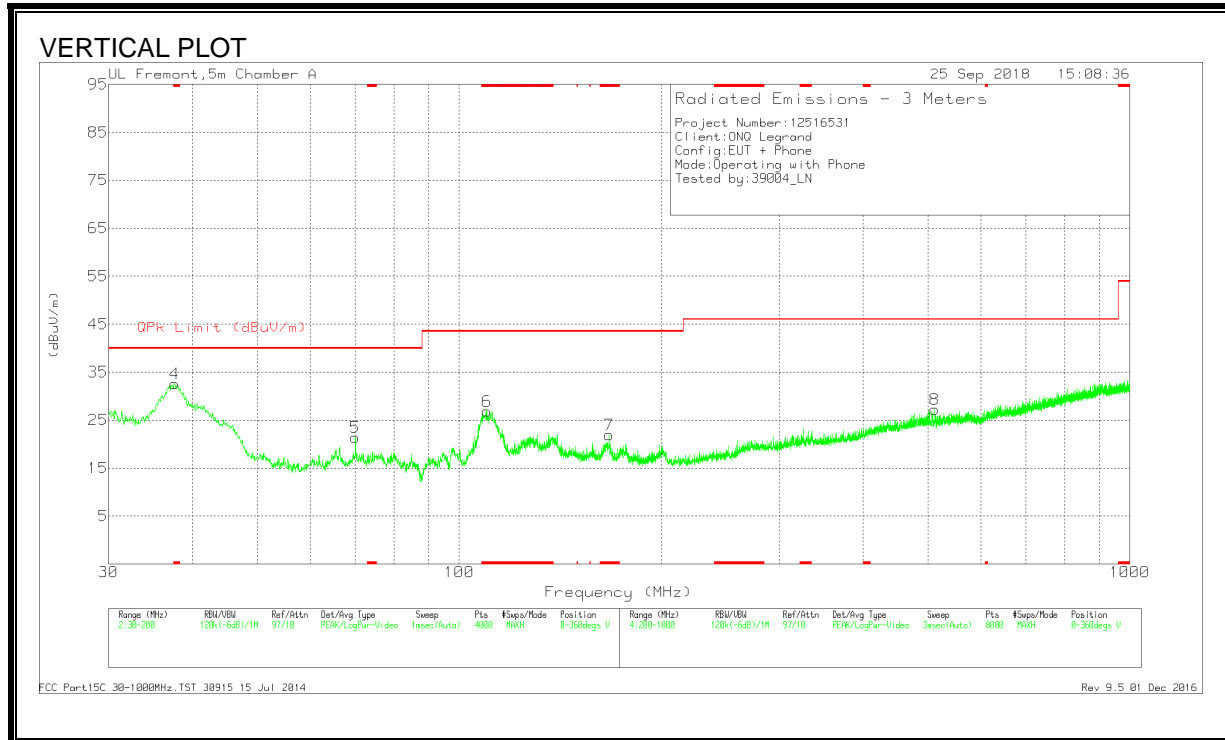
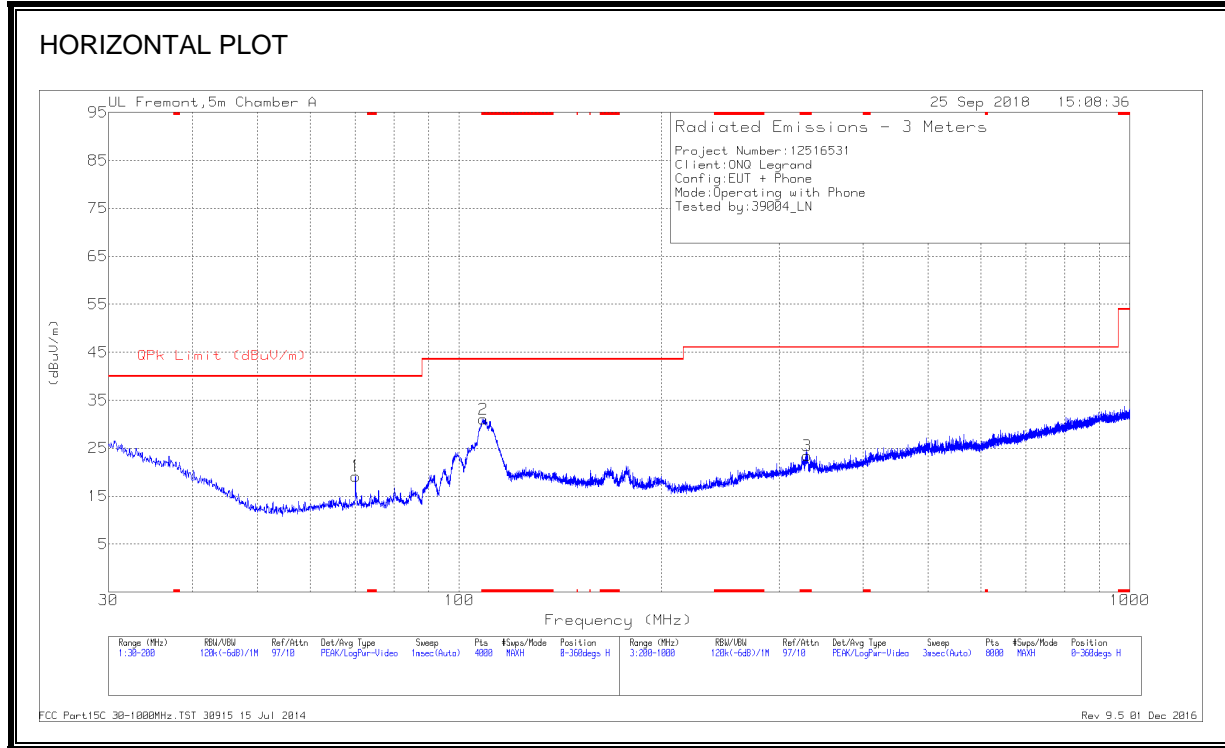

DATA

Marker	Frequency (MHz)	Meter Reading (dBuV)	Det	AF T130 (dB/m)	Amp/Cbl (dB/m)	Corrected Reading (dBuV/m)	QPk Limit (dBuV/m)	Margin (dB)	Azimuth (Degs)	Height (cm)	Polarity
2	* 108.6879	40.95	Pk	16.4	-26.3	31.05	43.52	-12.47	0-360	300	H
4	* 37.652	40.21	Pk	19.6	-27.2	32.61	40	-7.39	0-360	100	V
6	* 109.8994	36.58	Pk	16.6	-26.3	26.88	43.52	-16.64	0-360	100	V
3	* 330.417	30.27	Pk	17.9	-24.7	23.47	46.02	-22.55	0-360	101	H
5	70.0029	36.01	Pk	12.1	-26.7	21.41	40	-18.59	0-360	100	V
1	70.0454	33.79	Pk	12.1	-26.7	19.19	40	-20.81	0-360	100	H
7	167.3956	31.75	Pk	15.9	-25.7	21.95	43.52	-21.57	0-360	100	V
8	511.4405	30.85	Pk	21.7	-25.3	27.25	46.02	-18.77	0-360	101	V

\* - indicates frequency in CFR47 Pt 15 / IC RSS-Restricted Band

Pk - Peak detector

FCC Part15C 30-1000MHz.TST 30915 15 Jul 2014

Rev 9.5 01 Dec 2016

## 8.5. IC / CISPR 11 TX SPURIOUS EMISSION 30 TO 1000 MHz

### 8.5.1. STANDBY CONFIGURATION

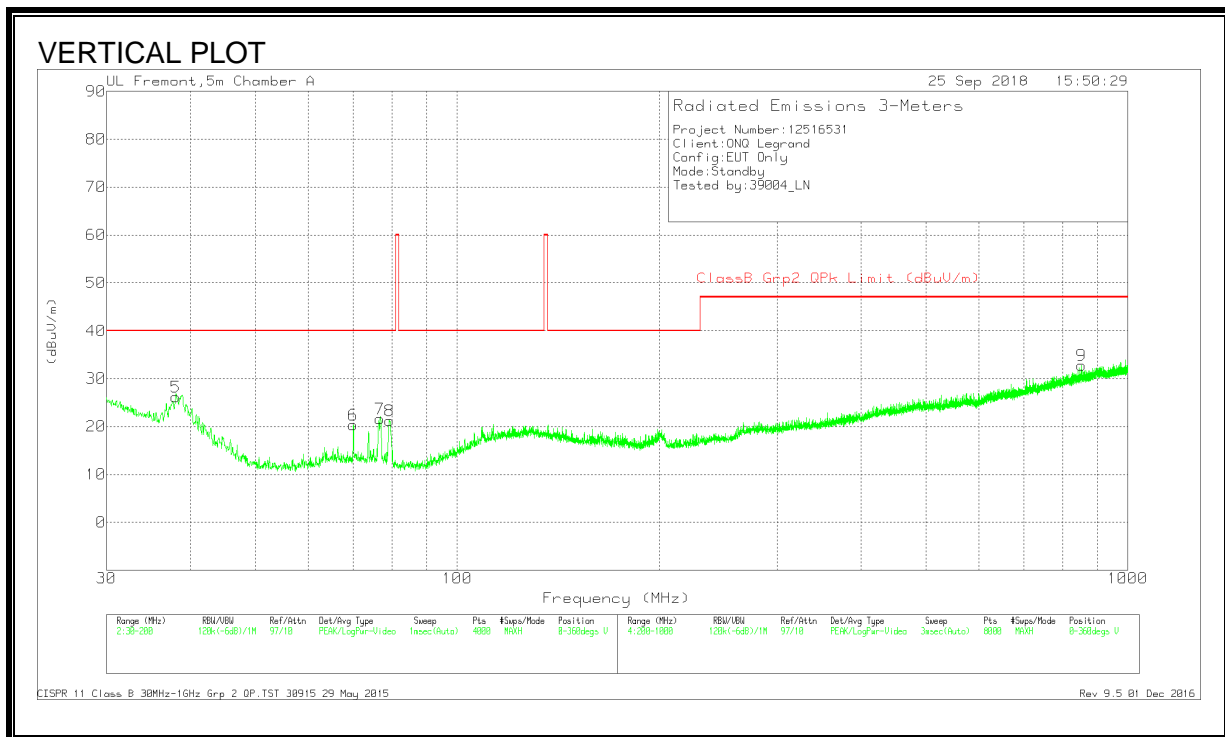
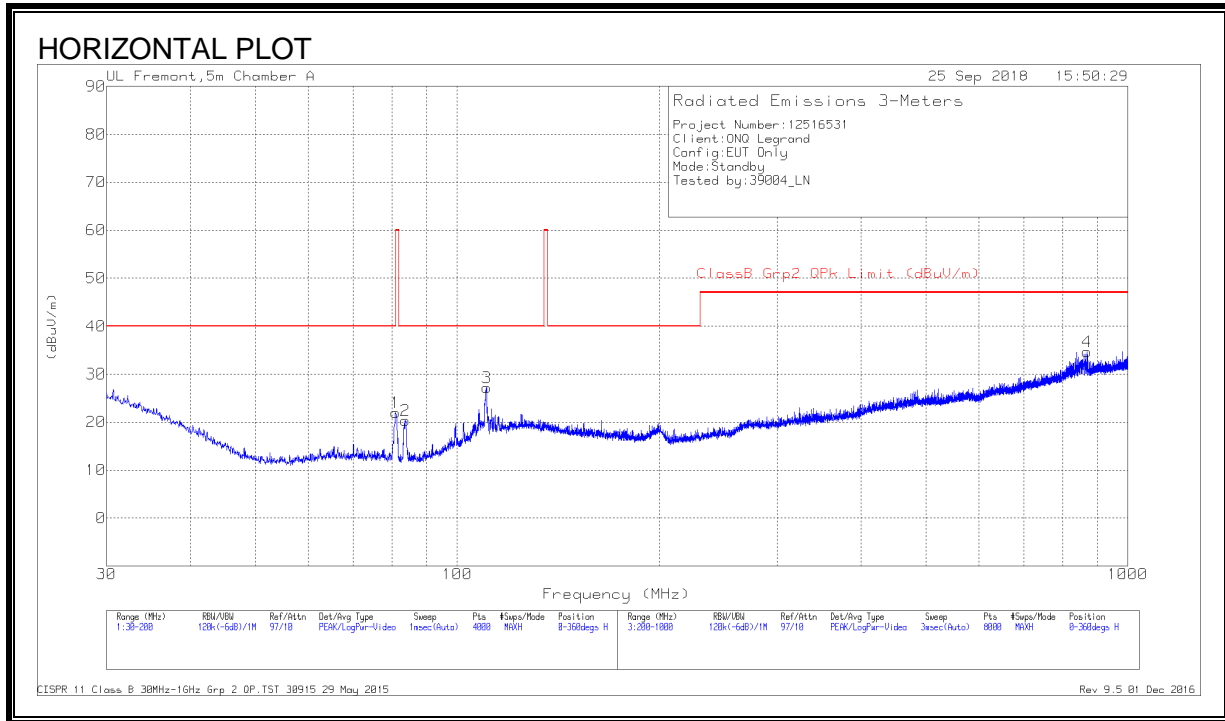

DATA

Marker	Frequenc y (MHz)	Meter Reading (dBuV)	Det	AF T130 (dB/m)	Amp/Cbl (dB/m)	Corrected Reading (dBuV/m)	ClassB Grp2 QPk Limit (dBuV/m)	Margin (dB)	Azimuth (Degs)	Height (cm)	Polarity
5	38.0346	34.02	Pk	19.4	-27.2	26.22	40	-13.78	0-360	100	V
6	70.0029	34.94	PK	12.1	-26.7	20.34	40	-19.66	0-360	100	V
7	76.7196	36.5	PK	11.8	-26.7	21.6	40	-18.4	0-360	100	V
8	79.3553	36.23	Pk	11.6	-26.6	21.23	40	-18.77	0-360	100	V
1	80.9282	37.2	PK	11.4	-26.6	22	60	-38	0-360	400	H
2	83.6489	35.66	PK	11.3	-26.6	20.36	40	-19.64	0-360	400	H
3	110.6009	36.8	Pk	16.7	-26.3	27.2	40	-12.8	0-360	300	H
9	853.3849	30.37	PK	25.8	-23.4	32.77	47	-14.23	0-360	300	V
4	869.7871	31.94	PK	25.9	-23.2	34.64	47	-12.36	0-360	101	H

Pk - Peak detector

CISPR 11 Class B 30MHz-1GHz Grp 2 QP.TST 30915 29 May 2015  
 Rev 9.5 01 Dec 2016

**8.5.2. COIL 1, OPERATING WITH PHONE**

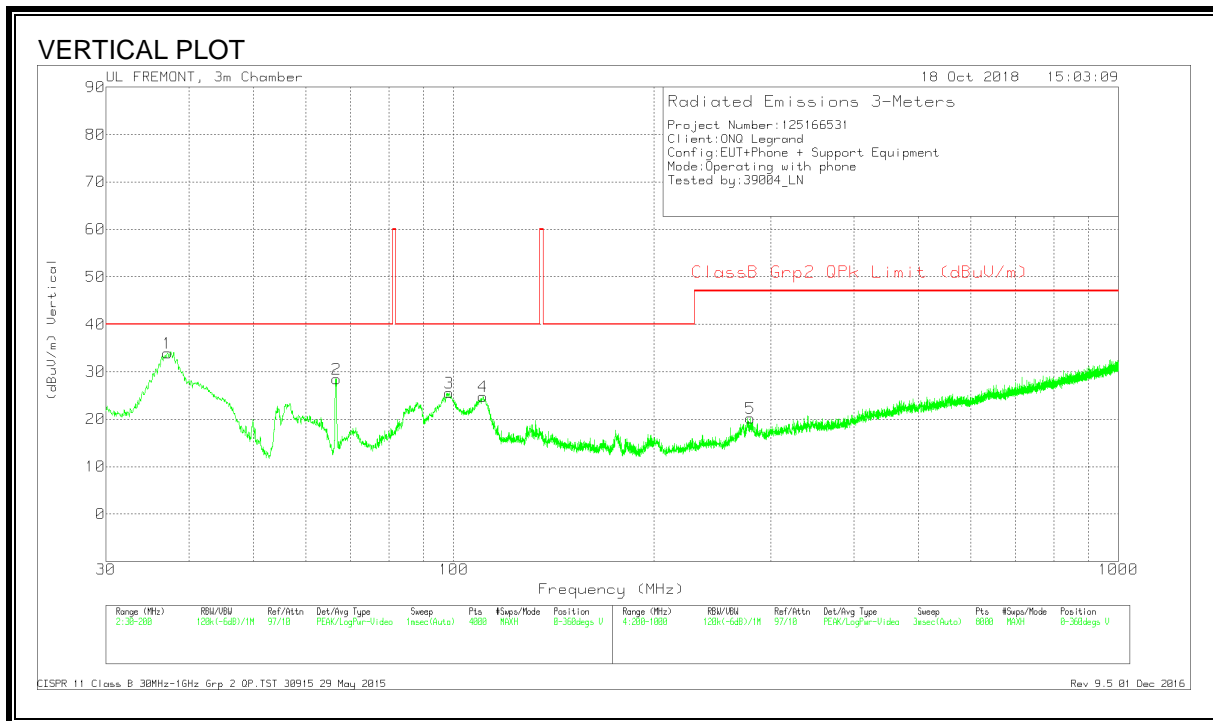
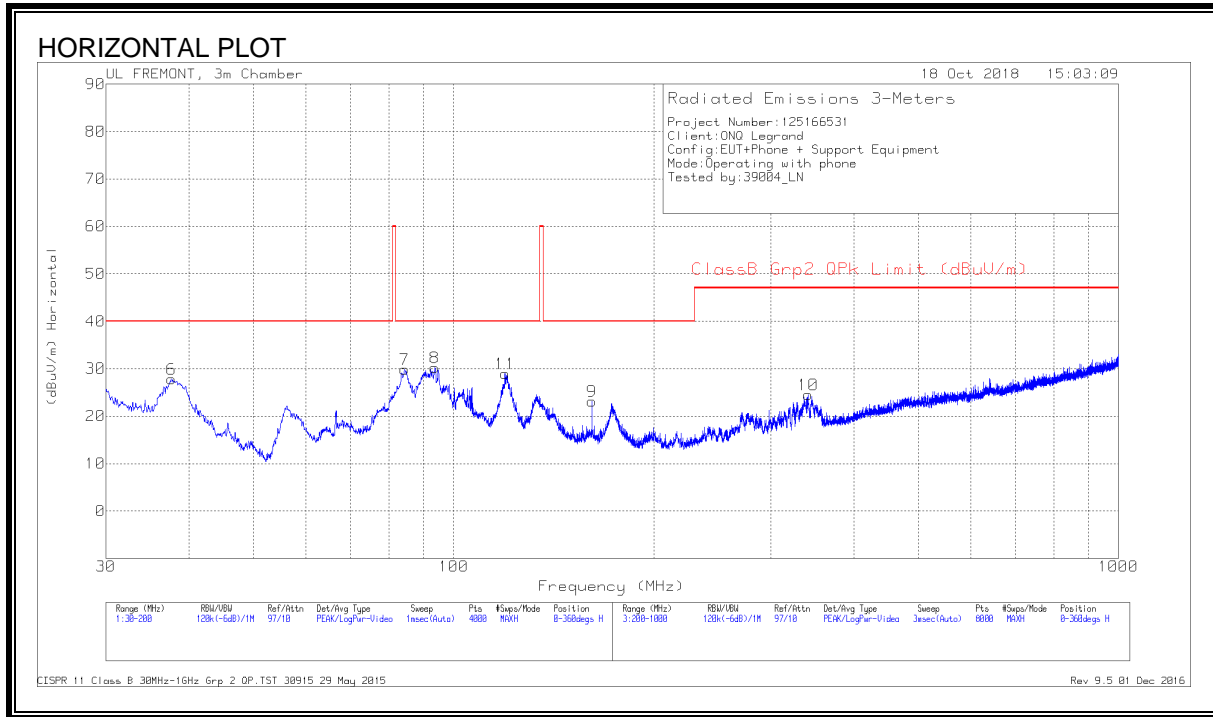



**DATA**

Marker	Frequency (MHz)	Meter Reading (dBuV)	Det	AF T243 (dB/m)	Amp/Cbl (dB/m)	Corrected Reading (dBuV/m)	ClassB Grp2 QPk Limit (dBuV/m)	Margin (dB)	Azimuth (Degs)	Height (cm)	Polarity
1	37.1418	44.93	Pk	20	-31	33.93	40	-6.07	0-360	100	V
6	37.652	39.21	Pk	19.6	-31	27.81	40	-12.19	0-360	400	H
2	66.6445	47.1	Pk	12	-30.6	28.5	40	-11.5	0-360	100	V
7	84.4566	49.03	Pk	11.3	-30.5	29.83	40	-10.17	0-360	300	H
8	93.7452	48.15	Pk	12.4	-30.3	30.25	40	-9.75	0-360	300	H
3	98.4427	42.04	Pk	13.8	-30.3	25.54	40	-14.46	0-360	100	V
4	110.7284	38.15	Pk	16.8	-30.2	24.75	40	-15.25	0-360	100	V
11	119.4644	41.23	Pk	17.9	-30.1	29.03	40	-10.97	0-360	200	H
9	161.529	36.79	Pk	16.1	-29.7	23.19	40	-16.81	0-360	200	H
5	279.7104	31.66	Pk	17.5	-28.9	20.26	47	-26.74	0-360	100	V
10	341.5184	35.08	Pk	18	-28.5	24.58	47	-22.42	0-360	100	H

Pk - Peak detector

CISPR 11 Class B 30MHz-1GHz Grp 2 QP.TST 30915 29 May 2015  
 Rev 9.5 01 Dec 2016

**8.5.3. COIL 2, OPERATING WITH PHONE**

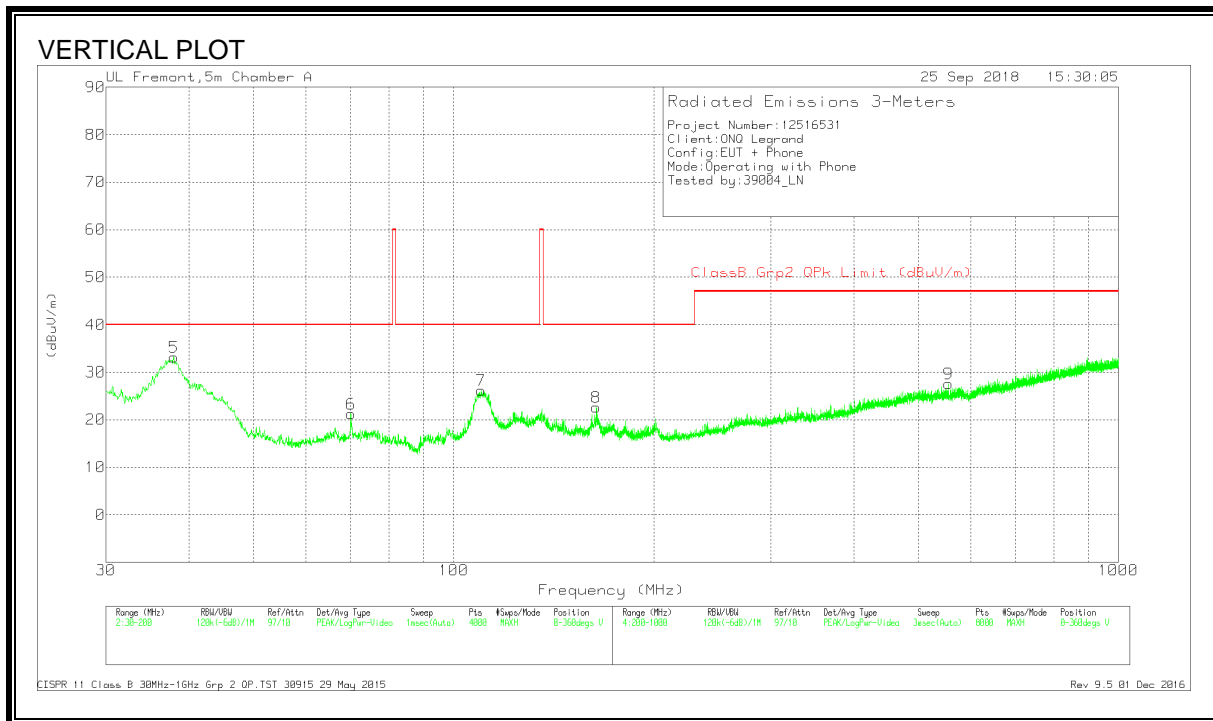
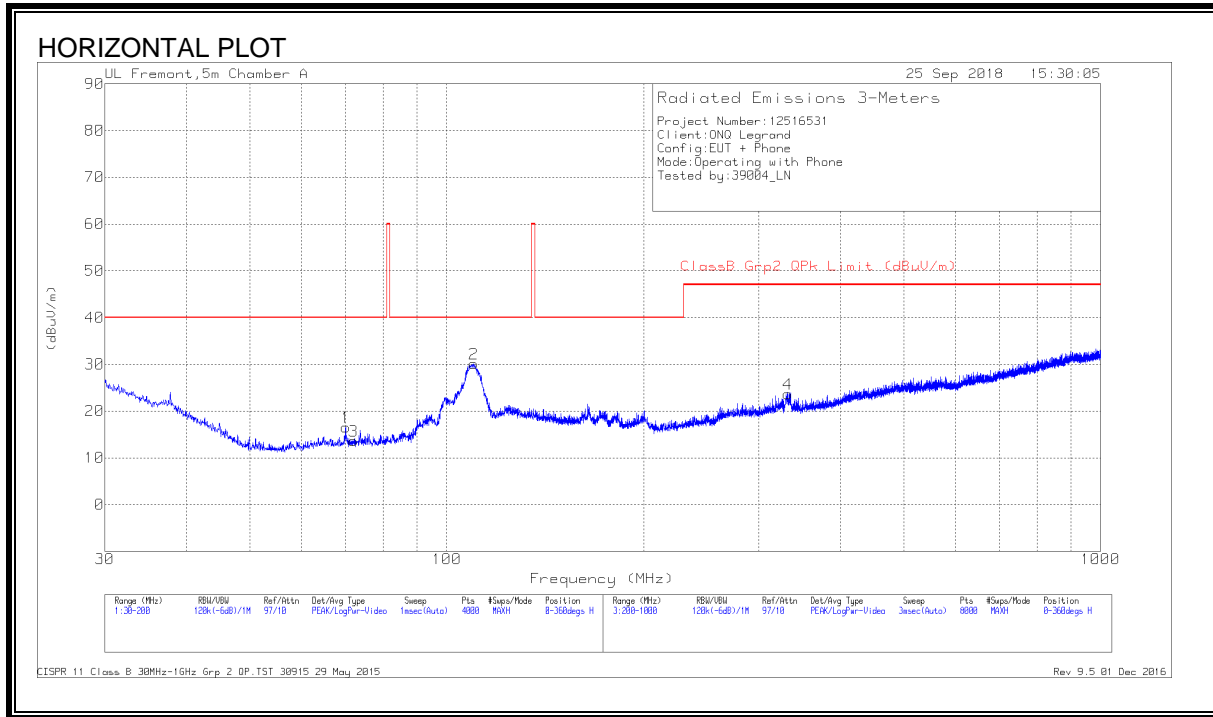

**DATA**

Marker	Frequency (MHz)	Meter Reading (dBuV)	Det	AF T130 (dB/m)	Amp/Cb l (dB/m)	Corrected Reading (dBuV/m)	ClassB Grp2 QPk Limit (dBuV/m)	Margin (dB)	Azimuth (Degs)	Height (cm)	Polarity
5	37.9496	40.99	Pk	19.4	-27.2	33.19	40	-6.81	0-360	100	V
1	70.0454	31.09	Pk	12.1	-26.7	16.49	40	-23.51	0-360	300	H
6	70.0454	35.81	Pk	12.1	-26.7	21.21	40	-18.79	0-360	100	V
3	72.0009	28.19	Pk	12.1	-26.7	13.59	40	-26.41	0-360	200	H
2	110.0057	39.82	Pk	16.6	-26.3	30.12	40	-9.88	0-360	300	H
7	110.0057	35.88	Pk	16.6	-26.3	26.18	40	-13.82	0-360	100	V
8	163.9947	32.35	Pk	16	-25.7	22.65	40	-17.35	0-360	100	V
4	332.6172	30.49	Pk	17.9	-24.7	23.69	47	-23.31	0-360	101	H
9	555.0462	30.5	Pk	22.3	-25.2	27.6	47	-19.4	0-360	101	V

Pk - Peak detector

CISPR 11 Class B 30MHz-1GHz Grp 2 QP.TST 30915 29 May 2015  
 Rev 9.5 01 Dec 2016

## 9. AC POWER LINE CONDUCTED EMISSIONS

### LIMITS

FCC §15.207 (a)

RSS-Gen 8.8

Frequency of Emission (MHz)	Conducted Limit (dB $\mu$ V)	
	Quasi-peak	Average
0.15-0.5	66 to 56 *	56 to 46 *
0.5-5	56	46
5-30	60	50

\*Decreases with the logarithm of the frequency.

### TEST PROCEDURE

The EUT is placed on a non-conducting table 40 cm from the vertical ground plane and 80 cm above the horizontal ground plane. The EUT is configured in accordance with ANSI C63.10.

The receiver is set to a resolution bandwidth of 9 kHz. Peak detection is used unless otherwise noted as quasi-peak or average.

Line conducted data is recorded for both NEUTRAL and HOT lines.

### RESULTS

**9.1.1. STANDBY MODE POWERED BY AC/DC ADAPTER**

**LINE 1 RESULTS**

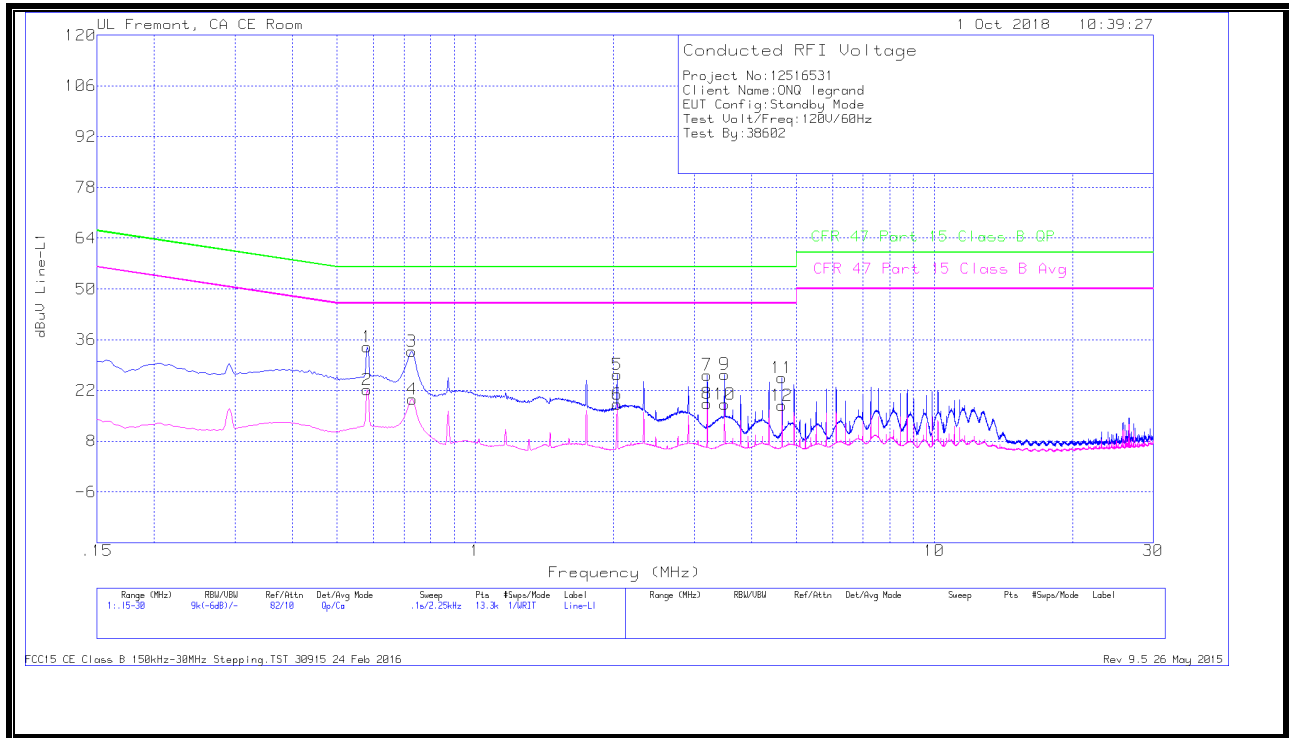

**WORST EMISSIONS**

Range 1: Line-L1 .15 - 30MHz											
Marker	Frequency (MHz)	Meter Reading (dBuV)	Det	LISN L1	LC Cables C1&C3	Limiter (dB)	Corrected Reading dBuV	CFR 47 Part 15 Class B QP	QP Margin (dB)	CFR 47 Part 15 Class B Avg	Av(CISPR)Margin (dB)
1	.582	23.87	Qp	0	0	10.1	33.97	56	-22.03	-	-
2	.582	12.09	Ca	0	0	10.1	22.19	-	-	46	-23.81
3	.72825	22.65	Qp	0	0	10.1	32.75	56	-23.25	-	-
4	.7305	9.48	Ca	0	0	10.1	19.58	-	-	46	-26.42
5	2.03775	16.14	Qp	0	.1	10.1	26.34	56	-29.66	-	-
6	2.03775	7.93	Ca	0	.1	10.1	18.13	-	-	46	-27.87
7	3.201	16.07	Qp	0	.1	10.1	26.27	56	-29.73	-	-
8	3.201	8.11	Ca	0	.1	10.1	18.31	-	-	46	-27.69
9	3.4935	16.24	Qp	0	.1	10.1	26.44	56	-29.56	-	-
10	3.4935	7.95	Ca	0	.1	10.1	18.15	-	-	46	-27.85
11	4.65675	15.28	Qp	0	.1	10.1	25.48	56	-30.52	-	-
12	4.65675	7.71	Ca	0	.1	10.1	17.91	-	-	46	-28.09

Qp - Quasi-Peak detector  
 Ca - CISPR average detection

**LINE 2 RESULTS**

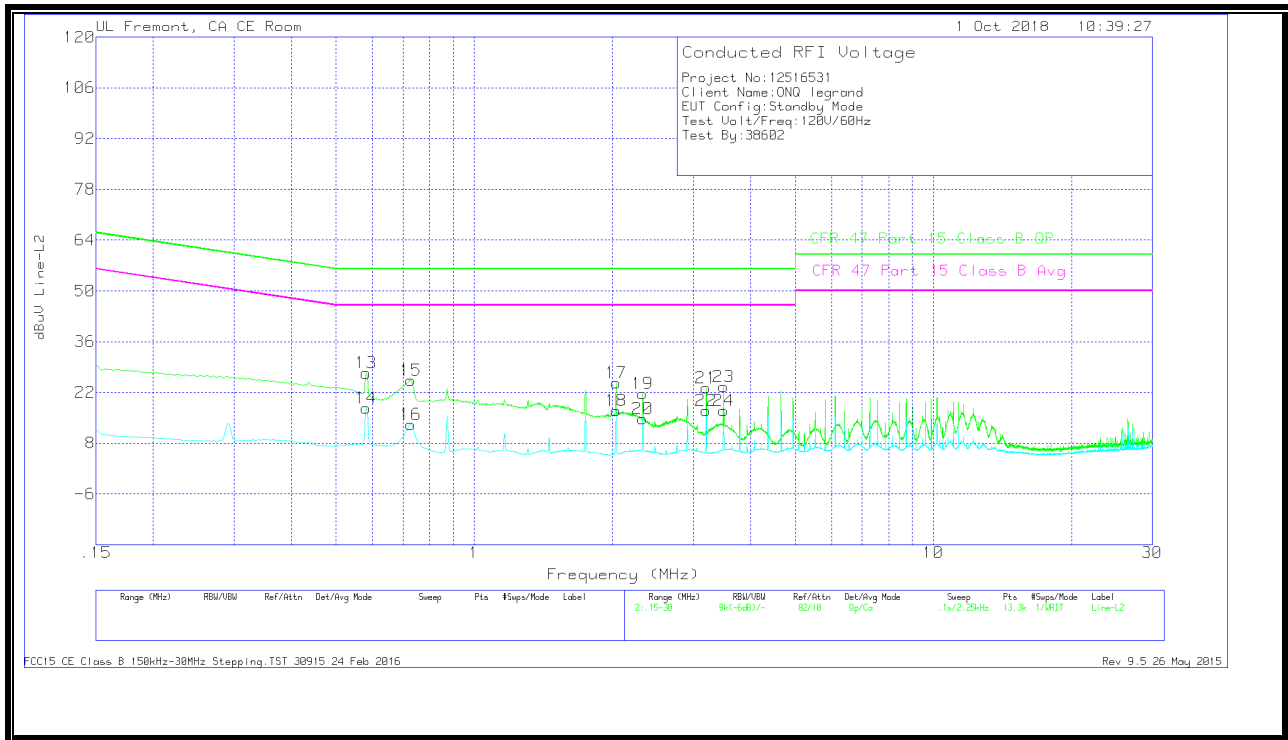

**WORST EMISSIONS**

Range 2: Line-L2 .15 - 30MHz											
Marker	Frequenc y (MHz)	Meter Reading (dBuV)	Det	LISN L2	LC Cables C2&C3	Limiter (dB)	Correcte d Reading dBuV	CFR 47 Part 15 Class B QP	QP Margin (dB)	CFR 47 Part 15 Class B Avg	Av(CISP R)Margin (dB)
13	.582	17.22	Qp	0	0	10.1	27.32	56	-28.68	-	-
14	.582	7.54	Ca	0	0	10.1	17.64	-	-	46	-28.36
15	.72712	15.18	Qp	0	0	10.1	25.28	56	-30.72	-	-
16	.72825	3.06	Ca	0	0	10.1	13.16	-	-	46	-32.84
17	2.03775	14.42	Qp	0	.1	10.1	24.62	56	-31.38	-	-
18	2.03775	6.74	Ca	0	.1	10.1	16.94	-	-	46	-29.06
19	2.328	11.53	Qp	0	.1	10.1	21.73	56	-34.27	-	-
20	2.328	4.48	Ca	0	.1	10.1	14.68	-	-	46	-31.32
21	3.20325	12.97	Qp	0	.1	10.1	23.17	56	-32.83	-	-
22	3.201	6.73	Ca	0	.1	10.1	16.93	-	-	46	-29.07
23	3.4935	13.33	Qp	0	.1	10.1	23.53	56	-32.47	-	-
24	3.4935	6.75	Ca	0	.1	10.1	16.95	-	-	46	-29.05

Qp - Quasi-Peak detector

Ca - CISPR average detection

FCC15 CE Class B 150kHz-30MHz Stepping.TST 30915 24 Feb 2016

Rev 9.5 26 May 2015

### 9.1.2. OPERATING MODE WITH PHONE

#### LINE 1 RESULTS

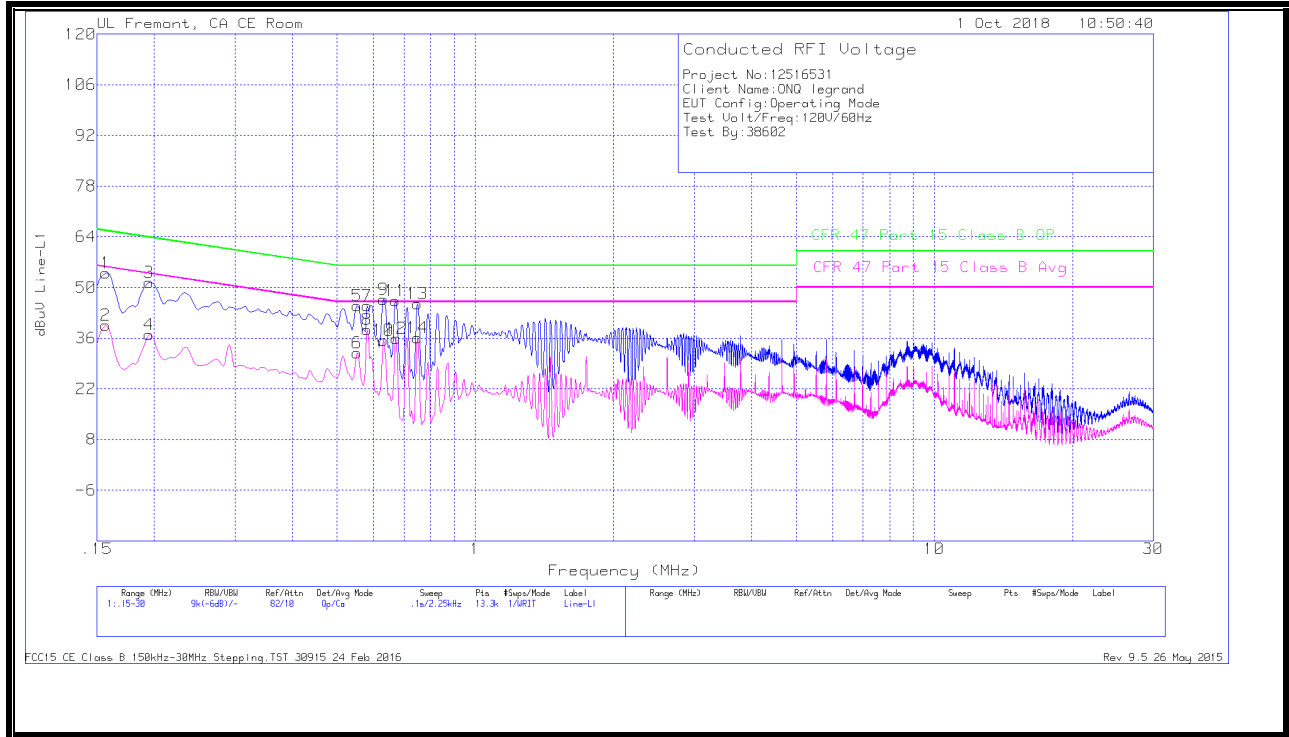

#### WORST EMISSIONS

Range 1: Line-L1 .15 - 30MHz											
Marker	Frequency (MHz)	Meter Reading (dBuV)	Det	LISN L1	LC Cables C1&C3	Limiter (dB)	Corrected Reading dBuV	CFR 47 Part 15 Class B QP	QP Margin (dB)	CFR 47 Part 15 Class B Avg	Av(CISPR)Margin (dB)
1	.15675	43.79	Qp	.1	0	10.1	53.99	65.63	-11.64	-	-
2	.15675	29.41	Ca	.1	0	10.1	39.61	-	-	55.63	-16.02
3	.195	41.33	Qp	0	0	10.1	51.43	63.82	-12.39	-	-
4	.195	26.86	Ca	0	0	10.1	36.96	-	-	53.82	-16.86
5	.55275	34.85	Qp	0	0	10.1	44.95	56	-11.05	-	-
6	.55275	21.76	Ca	0	0	10.1	31.86	-	-	46	-14.14
7	.582	34.92	Qp	0	0	10.1	45.02	56	-10.98	-	-
8	.582	28.32	Ca	0	0	10.1	38.42	-	-	46	-7.58
9	.6315	36.6	Qp	0	0	10.1	46.7	56	-9.3	-	-
10	.6315	25.37	Ca	0	0	10.1	35.47	-	-	46	-10.53
11	.66975	36.28	Qp	0	0	10.1	46.38	56	-9.62	-	-
12	.672	25.81	Ca	0	0	10.1	35.91	-	-	46	-10.09
13	.7485	35.45	Qp	0	0	10.1	45.55	56	-10.45	-	-
14	.7485	25.95	Ca	0	0	10.1	36.05	-	-	46	-9.95

Qp - Quasi-Peak detector  
 Ca - CISPR average detection

**LINE 2 RESULTS**

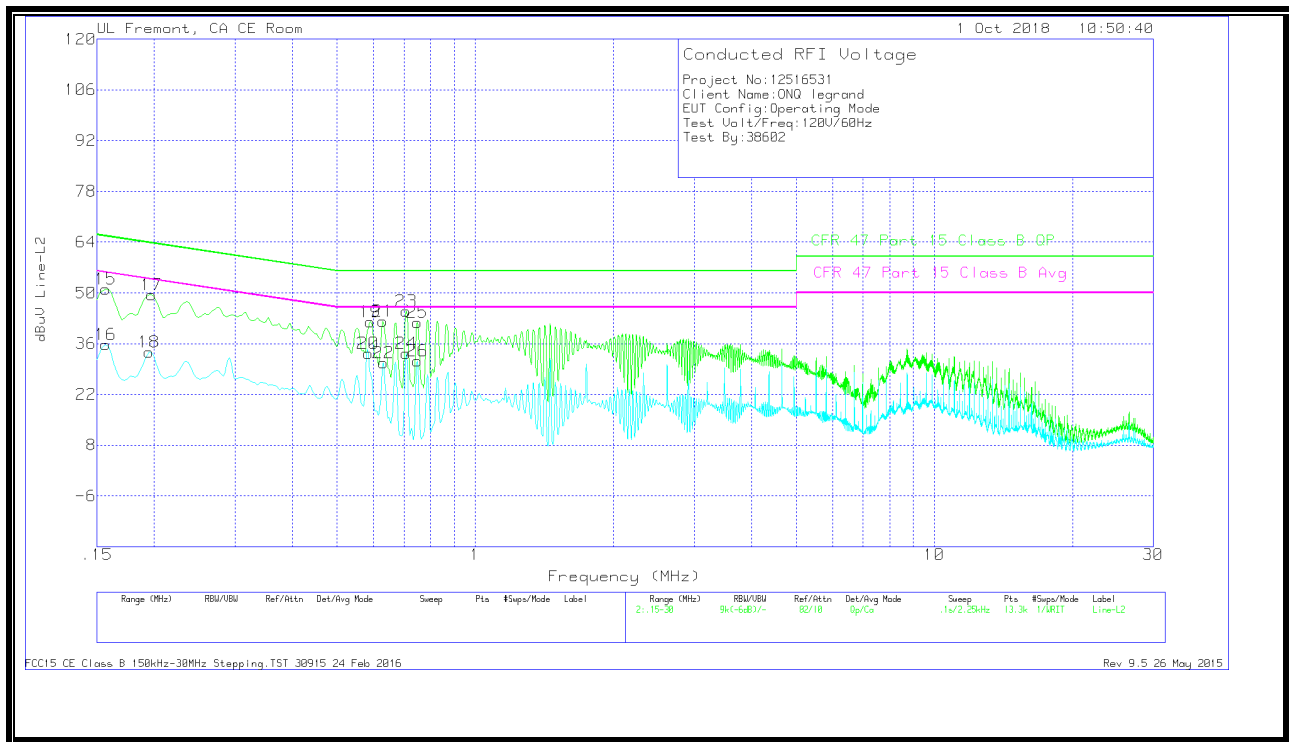

**WORST EMISSIONS**

Range 2: Line-L2 .15 - 30MHz											
Marker	Frequency (MHz)	Meter Reading (dBuV)	Det	LISN L2	LC Cables C2&C3	Limiter (dB)	Corrected Reading dBuV	CFR 47 Part 15 Class B QP	QP Margin (dB)	CFR 47 Part 15 Class B Avg	Av(CISPR)Margin (dB)
15	.15675	40.81	Qp	.1	0	10.1	51.01	65.63	-14.62	-	-
16	.15675	25.6	Ca	.1	0	10.1	35.8	-	-	55.63	-19.83
17	.19725	39.39	Qp	0	0	10.1	49.49	63.73	-14.24	-	-
18	.195	23.57	Ca	0	0	10.1	33.67	-	-	53.82	-20.15
19	.591	31.97	Qp	0	0	10.1	42.07	56	-13.93	-	-
20	.58425	23.21	Ca	0	0	10.1	33.31	-	-	46	-12.69
21	.62925	32.01	Qp	0	0	10.1	42.11	56	-13.89	-	-
22	.6315	20.59	Ca	0	0	10.1	30.69	-	-	46	-15.31
23	.708	34.91	Qp	0	0	10.1	45.01	56	-10.99	-	-
24	.708	23.14	Ca	0	0	10.1	33.24	-	-	46	-12.76
25	.7485	31.75	Qp	0	0	10.1	41.85	56	-14.15	-	-
26	.7485	21.11	Ca	0	0	10.1	31.21	-	-	46	-14.79

Qp - Quasi-Peak detector

Ca - CISPR average detection

FCC15 CE Class B 150kHz-30MHz Stepping.TST 30915 24 Feb 2016

Rev 9.5 26 May 2015