

LEGRAND HOME SYSTEMS, NORTH AMERICA

RF SWITCHED OUTLET

Model: ARPS15RF2W4 / ARPS15RF2M4

Nov 27th, 2012

Report No.: RF_SL12062002-LHS-007_FCC-IC

(This report supersedes None)



Modifications made to the product : None

This Test Report is Issued Under the Authority of:

	
Jason Zhang Compliance Engineer	David Zhang Engineering Reviewer

This test report may be reproduced in full only.
Test result presented in this test report is applicable to the representative sample only.

RF Test Report

To: FCC Part 15.247; 2011 & RSS 210 Issue 8; 2010

SIEMIC, INC.
Accessing global markets



Laboratory Introduction

SIEMIC, headquartered in the heart of Silicon Valley, with superior facilities in US and Asia, is one of the leading independent testing and certification facilities providing customers with one-stop shop services for Compliance Testing and Global Certifications.



In addition to [testing](#) and [certification](#), SIEMIC provides initial design reviews and [compliance management](#) through out a project. Our extensive experience with [China](#), [Asia Pacific](#), [North America](#), [European](#), and [international](#) compliance requirements, assures the fastest, most cost effective way to attain regulatory compliance for the [global markets](#).

Accreditations for Conformity Assessment

Country/Region	Accreditation Body	Scope
USA	FCC, A2LA	EMC , RF/Wireless , Telecom , SAR
Canada	IC, A2LA, NIST	EMC, RF/Wireless , Telecom , SAR
Taiwan	BSMI , NCC , NIST	EMC, RF, Telecom , Safety
Hong Kong	OFTA , NIST	RF/Wireless ,Telecom
Australia	NATA, NIST	EMC, RF, Telecom , Safety
Korea	KCC/RRA, NIST	EMI, EMS, RF , Telecom, Safety , SAR
Japan	VCCI, JATE, TELEC, RFT	EMI, RF/Wireless, Telecom
Mexico	NOM, COFETEL, Caniety	Safety, EMC , RF/Wireless, Telecom
Europe	A2LA, NIST	EMC, RF, Telecom , Safety, SAR

Accreditations for Product Certifications

Country	Accreditation Body	Scope
USA	FCC TCB, NIST	EMC , RF , Telecom
Canada	IC FCB, NIST	EMC , RF , Telecom
Singapore	iDA, NIST	EMC , RF , Telecom
EU	NB	EMC & R&TTE Directive
Japan	MIC, (RCB 208)	RF , Telecom
HongKong	OFTA (US002)	RF , Telecom

A

SIEMIC, INC.

Accessing global markets

Title: RF Test Report of RF Switched Outlet
Model: ARPS15RF2W4 / ARPS15RF2M4
To: FCC 15.247:2011, RSS-210 Issue 8:2010

Serial# RF_SL12062002-LHS-007_FCC-IC
Issue Date Nov 27th, 2012
Page 3 of 74
www.siemec.com

This page has been left blank intentionally.

CONTENTS

1	EXECUTIVE SUMMARY & EUT INFORMATION.....	6
2	TECHNICAL DETAILS	7
3	MODIFICATION	8
4	TEST SUMMARY	9
5	MEASUREMENTS, EXAMINATION AND DERIVED RESULTS	10
ANNEX A. TEST INSTRUMENT & METHOD		37
ANNEX B. EUT AND TEST SETUP PHOTOGRAPHS		41
ANNEX C. TEST SETUP AND SUPPORTING EQUIPMENT		42
ANNEX D. USER MANUAL, BLOCK & CIRCUIT DIAGRAM		46
ANNEX E SIEMIC ACCREDITATION		错误!未定义书签。

A



SIEMIC, INC.
Accessing global markets

Title:	RF Test Report of RF Switched Outlet	Serial#	RF_SL12062002-LHS-007_FCC-IC
Model:	ARPS15RF2W4 / ARPS15RF2M4	Issue Date	Nov 27th, 2012
To:	FCC 15.247:2011, RSS-210 Issue 8:2010	Page	5 of 74
			www.siemec.com

This page has been left blank intentionally.

1 Executive Summary & EUT information

The purpose of this test programme was to demonstrate compliance of the Legrand Home Systems, North America RF Switched Outlet, against the current Stipulated Standards. The RF Switched Outlet has demonstrated compliance with the FCC 15.247:2011 and RSS-210 Issue 8:2010.

EUT Information

EUT Description	RF Switched Outlet
Model No	ARPS15RF2W4 / ARPS15RF2M4
Serial No	785007045987
Input Power	120V/60Hz AC
Classification Per Stipulated Test Standard	Spread Spectrum System / Device
Family Model Difference	Only color difference, internal PCB and components are the same. ARPS15RF2W4 represent for White color and ARPS15RF2M4 represent for Magnesium color

2 TECHNICAL DETAILS

Purpose	Compliance testing of RF Switched Outlet with stipulated standard
Applicant / Client	Legrand Home Systems, North America
Manufacturer	Legrand Home Systems, North America 301 Fulling Mill Rd, Suite G Middletown, PA 17057, USA
Laboratory performing the tests	SIEMIC Laboratories 775 Montague Expressway, Milpitas, CA 95035
Test report reference number	RF_SL12062002-LHS-007_FCC-IC
Date EUT received	Sep 1st, 2012
Standard applied	47 CFR §15.247: 2011 & RSS-210 Issue 8:2010
Dates of test (from – to)	Nov 10th - Nov 23th, 2012
No of Units:	2
Equipment Category:	DTS
Trade Name:	Legrand Home Systems, North America
Model :	ARPS15RF2W4 / ARPS15RF2M4
RF Operating Frequency (ies)	904.861 MHz to 924.873 MHz
Number of Channels :	5
Modulation :	Spread Spectrum System / Device
Antenna Resonate Frequency:	915 ± 30MHz
Antenna Impedance:	50 Ω
FCC ID :	YV-ARPS15RF2
IC ID :	9922A-ARPS15RF2

A

3 MODIFICATION

NONE

4 TEST SUMMARY

The product was tested in accordance with the following specifications. All testing has been performed according to below product classification:

Spread Spectrum System / Device

Test Results Summary

Test Standard		Description	Pass / Fail
47 CFR Part 15.247:2011	RSS-210 Issue 8:2010		
15.203		Antenna Requirement	Pass
15.205	RSS210(A8.5)	Restricted Band of Operation	Pass
15.207(a)	RSS210(A8.1)	AC Line Conducted Emissions Voltage	Pass
15.247(a) (1)	RSS210(A8.1)	Channel Separation	Pass
15.247(a)(1)	RSS210 (A8.2)	Occupied Bandwidth	Pass
15.247(a) (2)	RSS210(A8.1)	6dB Occupied Bandwidth	N/A
15.247(a) (1) (i)	RSS210(A8.1)	Number of Hopping Channels	N/A
15.247(a) (1) (i)	RSS210(A8.4)	Time of Occupancy	Pass
15.247(b) (2)	RSS210(A8.4)	Output Power	Pass
15.247(c)	RSS210(A8.5)	Antenna Gain > 6 dBi	N/A
15.209; 15.247(d)	RSS210(A8.5)	Radiated Spurious Emissions	Pass
15.247(e)	RSS210(A8.3)	Power Spectral Density	Pass
15.247(f)	RSS210(A8.3)	Hybrid System Requirement	Pass
15.247(i) §2.1091& §2.1093	RSSGen(5.5)	Maximum Permissible Exposure	Pass
15.247 (d)	RSS210(A8.5)	100 kHz Bandwidth of Frequency Band Edge	Pass

ANSI C63.4: 2009/ RSS-Gen Issue 3: 2010

Test Procedure: KDB 558074 DS01 V02

PS: All measurement uncertainties are not taken into consideration for all presented test result.

5 MEASUREMENTS, EXAMINATION AND DERIVED RESULTS

5.1 Antenna Requirement

Requirement(s): 47 CFR §15.203

An intentional radiator shall be designed to ensure that no antenna other than that furnished by the responsible party shall be used with the device.

Antenna requirement must meet at least one of the following:

- a) Antenna must be permanently attached to the device.
 - b) Antenna must use a unique type of connector to attach to the device.
 - c) Device must be professionally installed. Installer shall be responsible for ensuring that the correct antenna is employed with the device.
- 1) The antenna was PCB integrated to the board with a gain of -1 dBi which meets the requirement.

5.2 Conducted Emissions Voltage

Requirement:

Frequency of emission (MHz)	Conducted limit (dB μ V)	
	Quasi-peak	Average
0.15–0.5	66 to 56*	56 to 46*
0.5–5	56	46
5–30	60	50

*Decreases with the logarithm of the frequency.

Procedures:

- All possible modes of operation were investigated. Only the 6 worst case emissions measured, using the correct CISPR and Average detectors, are reported. All other emissions were relatively insignificant.
- A "-ve" margin indicates a PASS as it refers to the margin present below the limit line at the particular frequency.
- Conducted Emissions Measurement Uncertainty
All test measurements carried out are traceable to national standards. The uncertainty of the measurement at a confidence level of approximately 95% (in the case where distributions are normal), with a coverage factor of 2, in the range 9kHz – 30MHz (Average & Quasi-peak) is ± 3.86 dB.
- Environmental Conditions

Temperature	23°C
Relative Humidity	50%
Atmospheric Pressure	1019mbar

Test Date : Nov 10th- Nov 23th, 2012
 Tested By : Jason Zhang

Results: Pass

A

SIEMIC, INC.

Accessing global markets

Title: RF Test Report of RF Switched Outlet
 Model: ARPS15RF2W4 / ARPS15RF2M4
 To: FCC 15.247:2011, RSS-210 Issue 8:2010

Serial# RF_SL12062002-LHS-007_FCC-IC
 Issue Date Nov 27th, 2012
 Page 12 of 74
 www.siemic.com

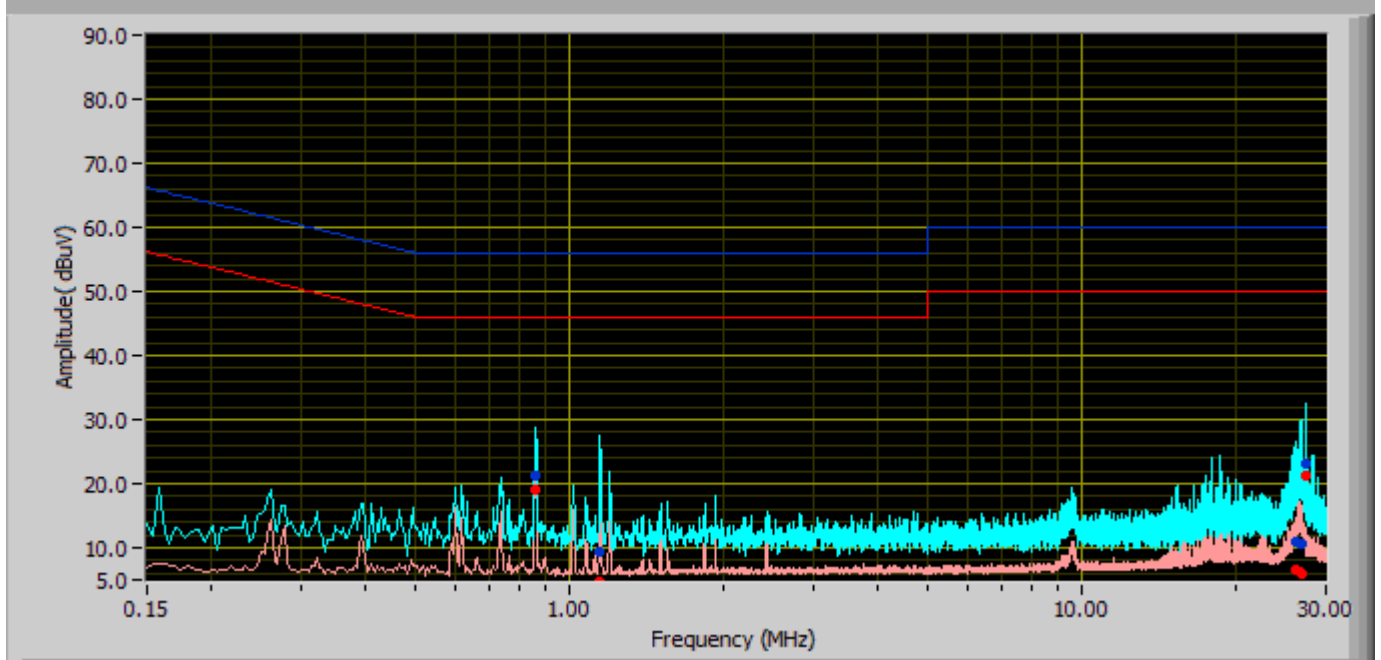
Final plot

Quasi-Peak Limit

Average Limit

Neutral Line Plot at 120VAC, 60Hz

Frequency (MHz)	QP Value (dB μ V)	Class B Limit (dB)	Margin (dB)	Avg Value (dB μ V)	Class B Limit (dB)	Margin (dB)	Line
0.86	21.37	56.00	-34.64	19.03	46.00	-26.98	Neutral
1.15	9.29	56.00	-46.71	4.77	46.00	-41.23	Neutral
26.25	10.79	60.00	-49.21	6.54	50.00	-43.46	Neutral
26.79	10.69	60.00	-49.31	6.14	50.00	-43.86	Neutral
27.01	10.71	60.00	-49.29	6.01	50.00	-43.99	Neutral
27.35	23.03	60.00	-36.97	21.29	50.00	-28.71	Neutral

Final plot

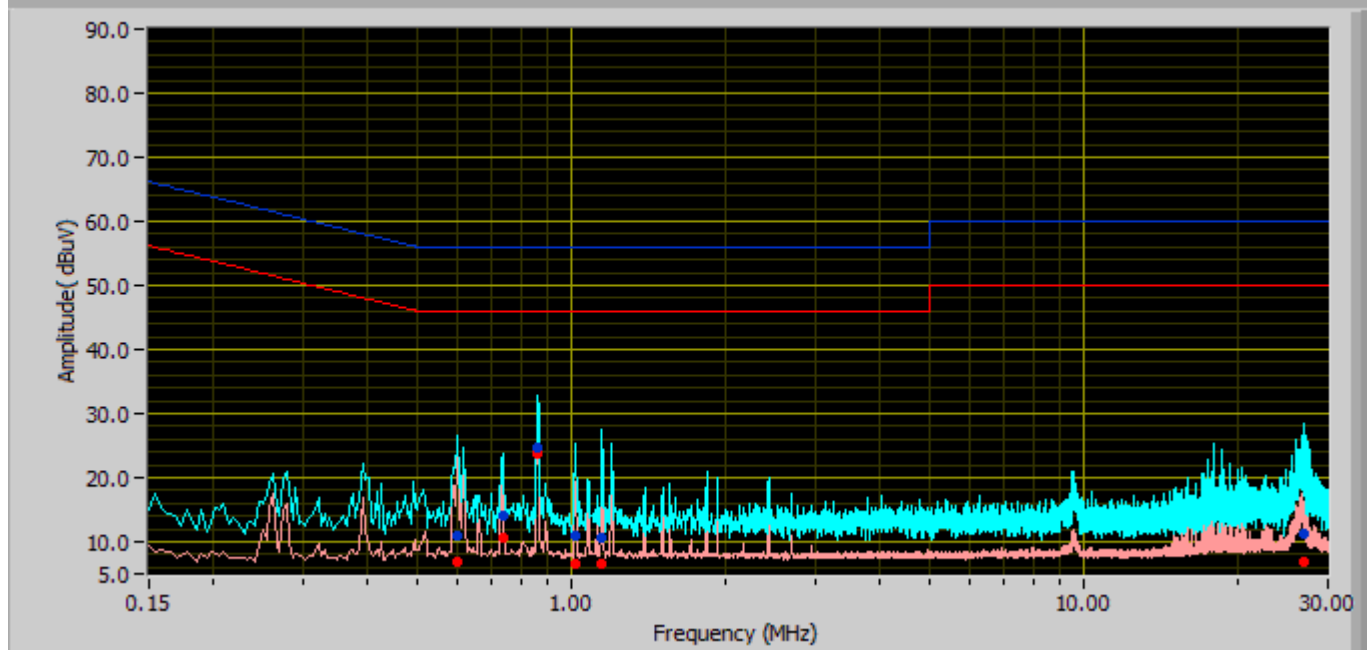

Quasi-Peak Limit

Average Limit

Phase Line Plot at 120VAC, 60Hz

Frequency (MHz)	QP Value (dB μ V)	Class B Limit (dB)	Margin (dB)	Avg Value (dB μ V)	Class B Limit (dB)	Margin (dB)	Line
0.60	11.05	56.00	-44.95	6.83	46.00	-39.17	Phase
0.73	14.04	56.00	-41.96	10.71	46.00	-35.29	Phase
0.86	24.73	56.00	-31.27	23.62	46.00	-22.38	Phase
1.02	10.87	56.00	-45.13	6.41	46.00	-39.59	Phase
1.15	10.76	56.00	-45.25	6.55	46.00	-39.46	Phase
26.98	11.34	60.00	-48.66	6.93	50.00	-43.07	Phase

5.3 Channel Separation

1. Conducted Measurement
 EUT was set for low, mid, high channel with modulated mode and highest RF output power.
 The spectrum analyzer was connected to the antenna terminal.
2. Environmental Conditions

Temperature	20°C
Relative Humidity	50%
Atmospheric Pressure	1019mbar
3. Conducted Emissions Measurement Uncertainty
 All test measurements carried out are traceable to national standards. The uncertainty of the measurement at a confidence level of approximately 95% (in the case where distributions are normal), with a coverage factor of 2, in the range 30MHz – 20GHz is ± 1.5 dB.
4. Test Date : Nov 10th- Nov 23th, 2012
 Tested By : Jason Zhang

Requirement(s): 47 CFR §15.247(a)(1)(i)

Procedures: The Channel Separation was measured conducted using a spectrum analyzer at low, mid, and hi channels.

Frequency hopping systems in the 902-928 MHz shall have, hopping channel carrier frequencies separated by a minimum of 25 kHz or the 20 dB bandwidth of the hopping channel, whichever is greater. The system shall hop to channel frequencies that are selected at the system hopping rate from a pseudo randomly ordered list of hopping frequencies.

Test Result: Pass

Channel	Channel Frequency (MHz)	Channel Separation (MHz)	20 dB Channel Bandwidth (KHz)
Low	904.861	5.98	1100
Mid	918.869	3.69	1090
High	924.873	2.32	1100

Channel Separation - Low Channel

	Delta 1 [T1]	RBW	100 kHz	RF Att	20 dB
	Ref Lvl	-0.03 dB	VBW	300 kHz	
	10 dBm	5.98196393 MHz	SWT	50 ms	Unit dBm

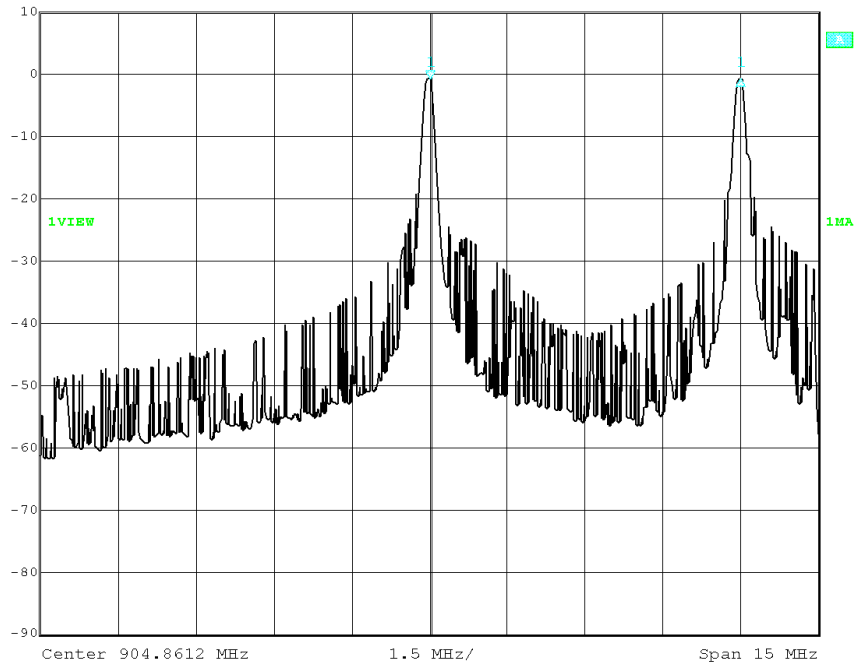

Channel Separation - Mid Channel

	Delta 1 [T1]	RBW	100 kHz	RF Att	20 dB
	Ref Lvl	-0.08 dB	VBW	300 kHz	
	10 dBm	-3.68737475 MHz	SWT	50 ms	Unit dBm

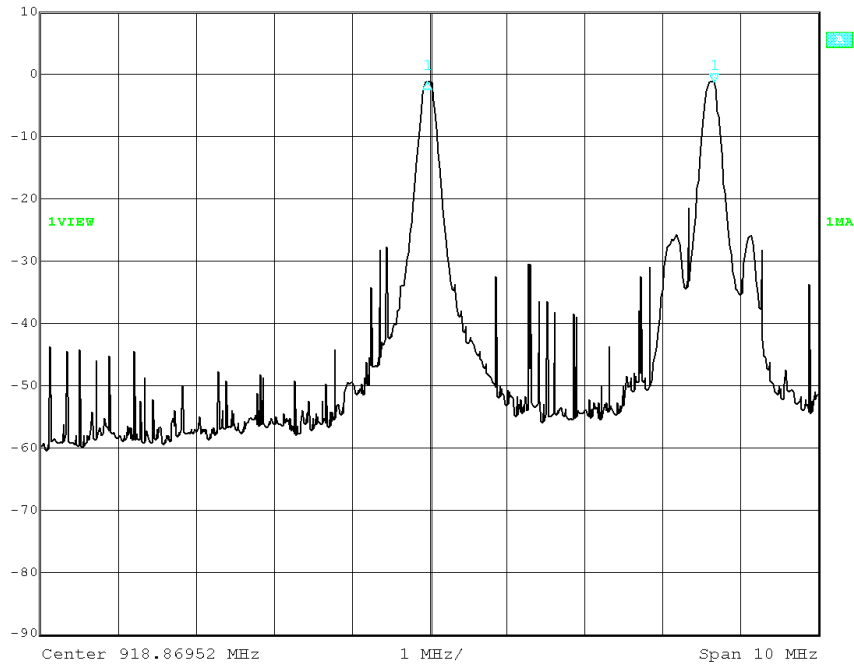

A

Channel Separation – High Channel

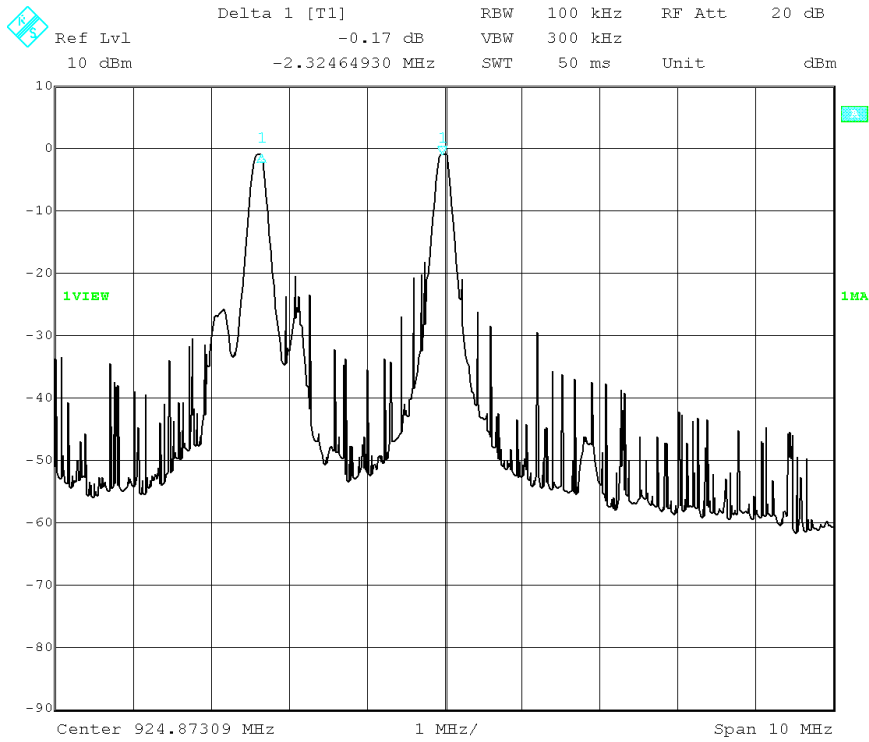

5.4 Occupied Bandwidth & band edge

1. Conducted Measurement
 EUT was set for low, mid, high channel with modulated mode and highest RF output power.
 The spectrum analyzer was connected to the antenna terminal.
2. Environmental Conditions

Temperature	20°C
Relative Humidity	50%
Atmospheric Pressure	1019mbar
3. Conducted Emissions Measurement Uncertainty
 All test measurements carried out are traceable to national standards. The uncertainty of the measurement at a confidence level of approximately 95% (in the case where distributions are normal), with a coverage factor of 2, in the range 30MHz – 20GHz is ± 1.5 dB.
4. Test Date : Nov 10th- Nov 23th, 2012
 Tested By : Jason Zhang

Requirement(s): 47 CFR §15.247(a)(1)(i):(d)

Procedures: The 20dB bandwidths were measured conducted using a spectrum analyzer at low, mid, and hi channels.

Test Result: Pass

Channel	Channel Frequency (MHz)	20 dB Channel Bandwidth (KHz)	99% Channel Bandwidth (KHz)
Low	904.861	1100	985
Mid	918.869	1090	985
High	924.873	1100	950

Refer to the attached plots.

20dB Bandwidth - Low Channel

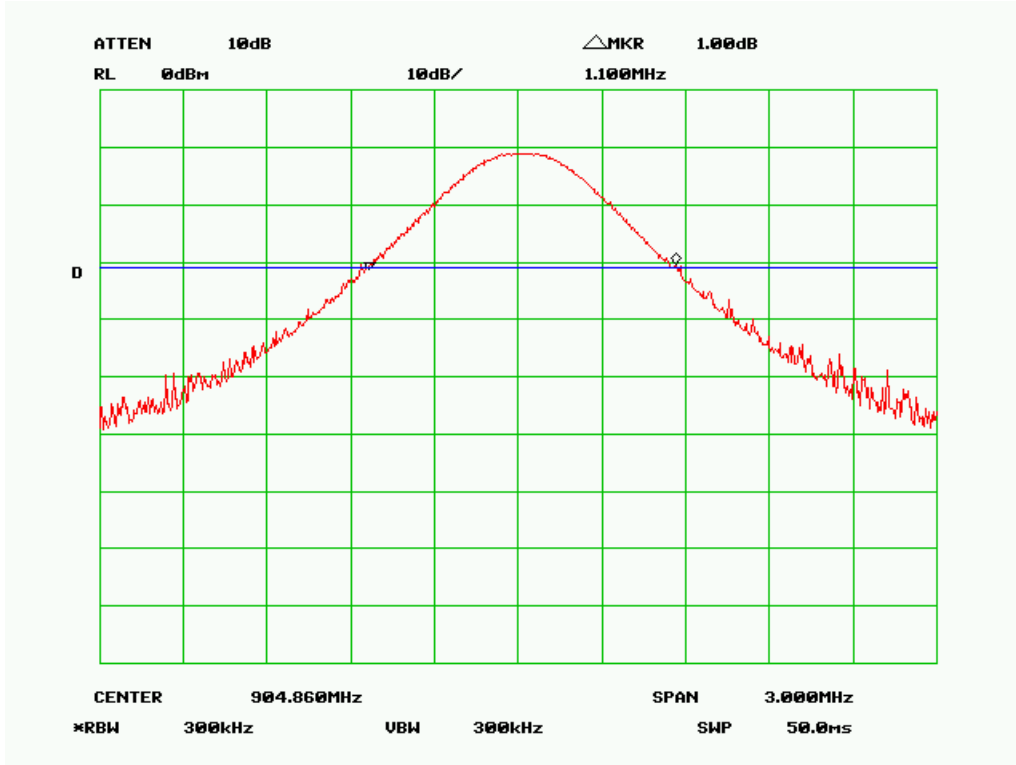

20dB Bandwidth - Mid Channel

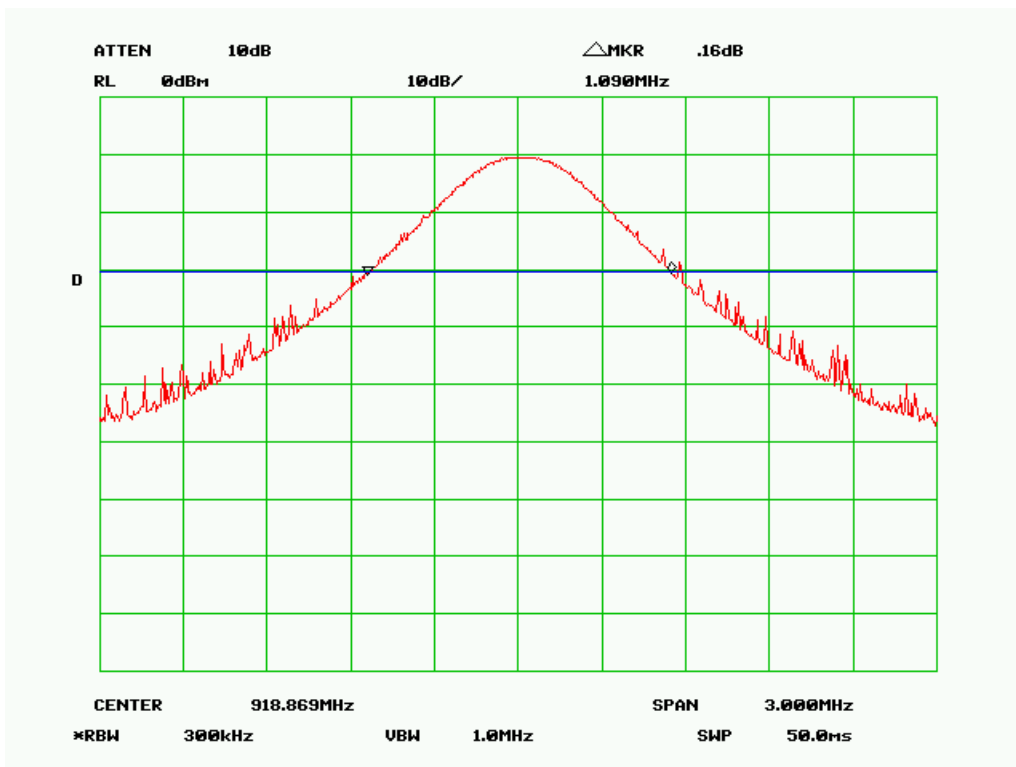

20dB Bandwidth - High Channel

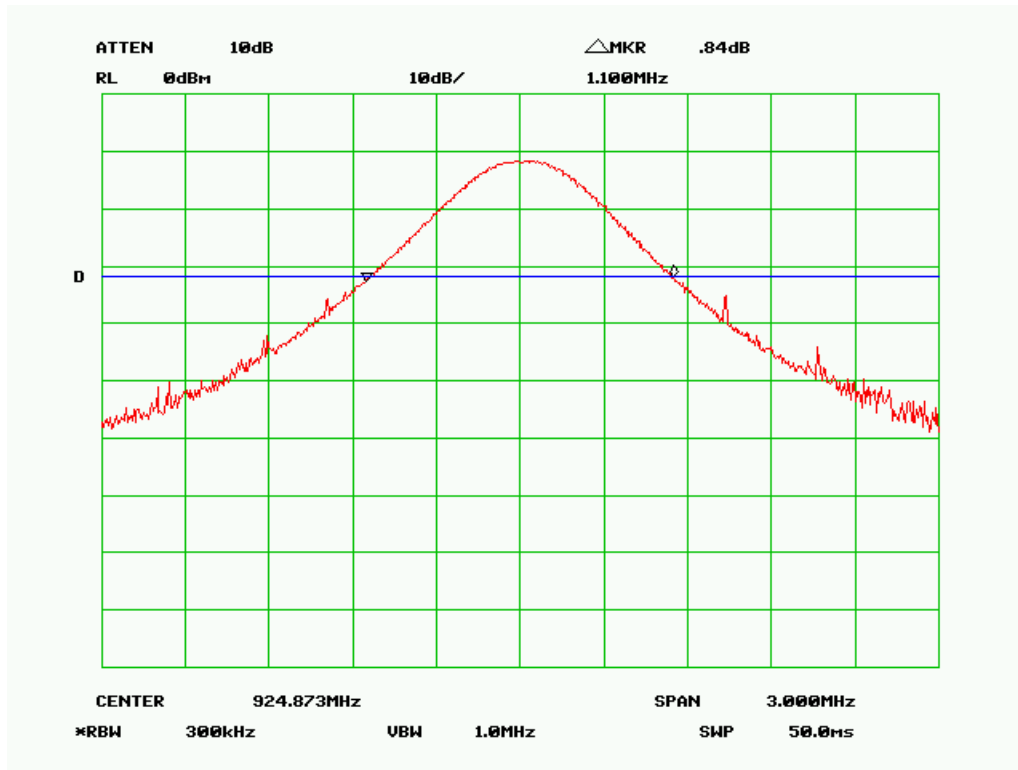

99% Occupied Bandwidth - Low Channel

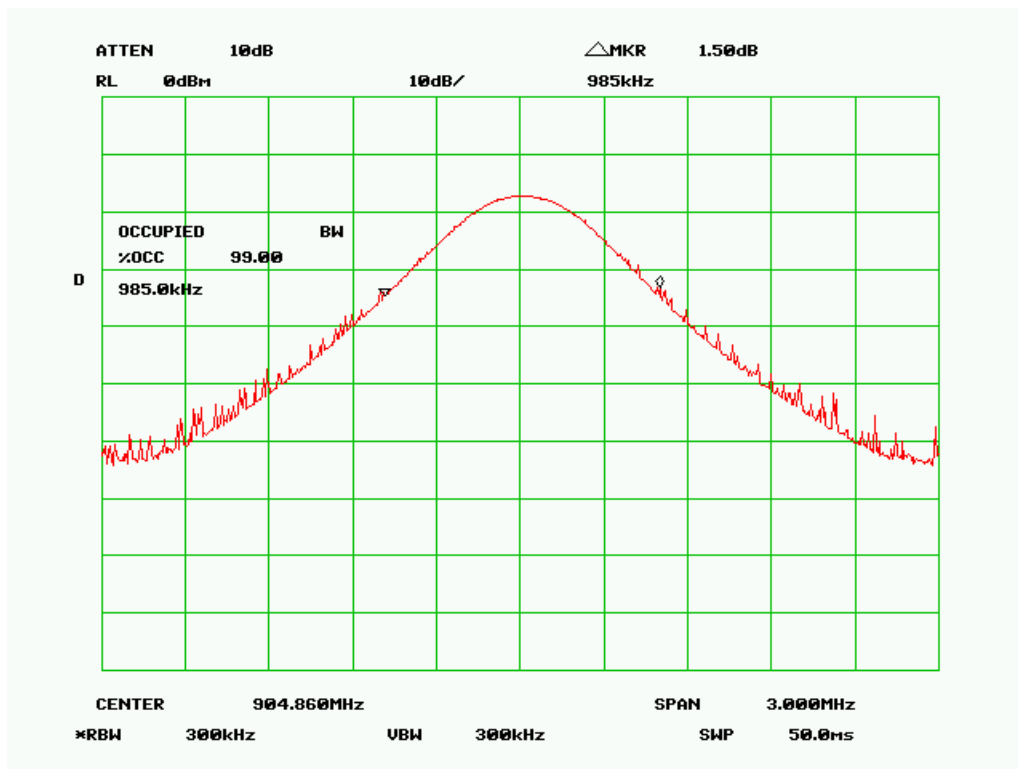

99% Occupied Bandwidth – Mid Channel

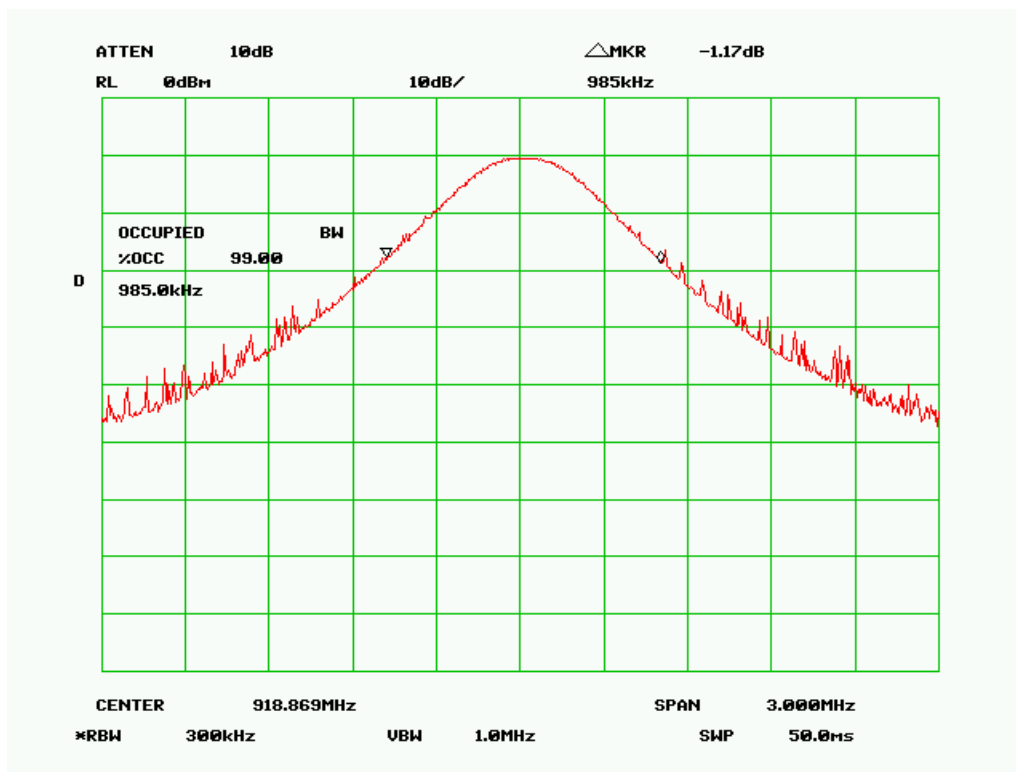

99% Occupied Bandwidth – High Channel

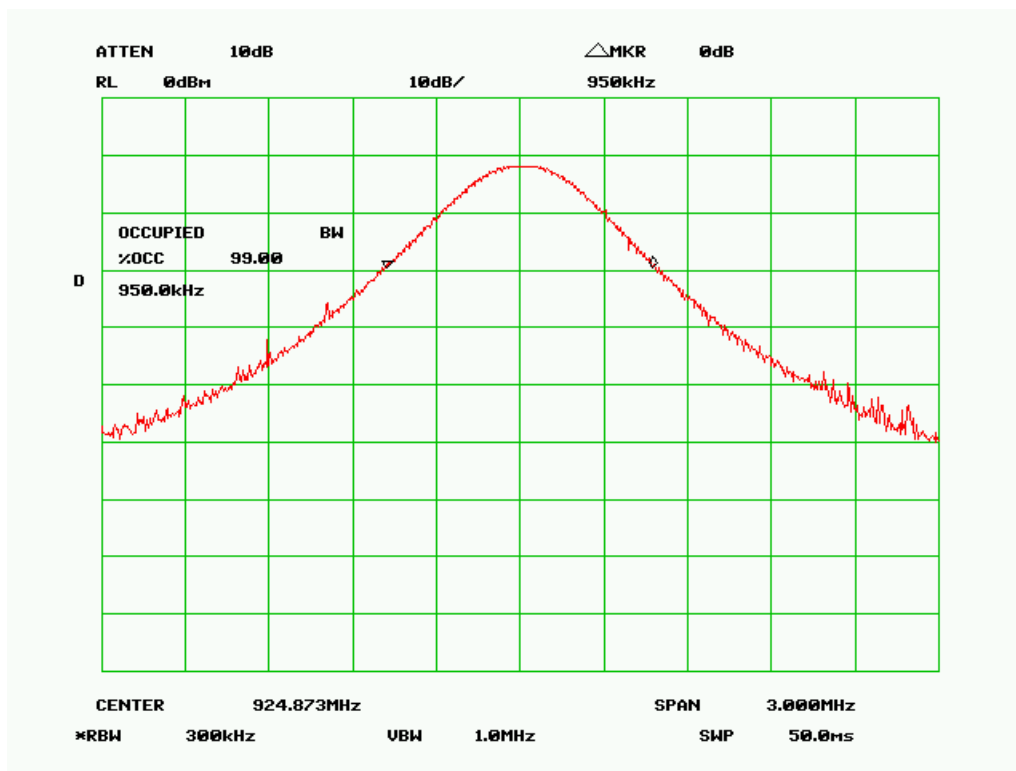

Low band edge

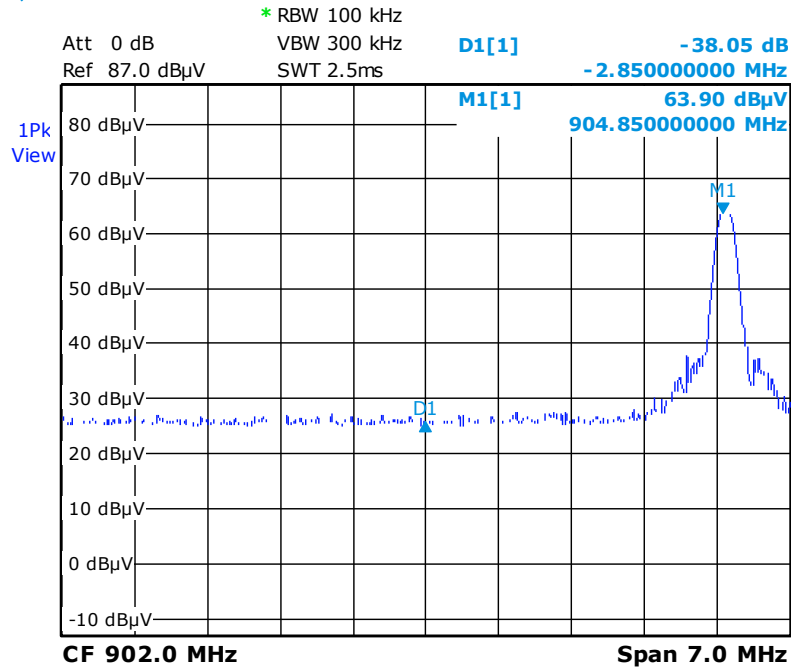

High band edge

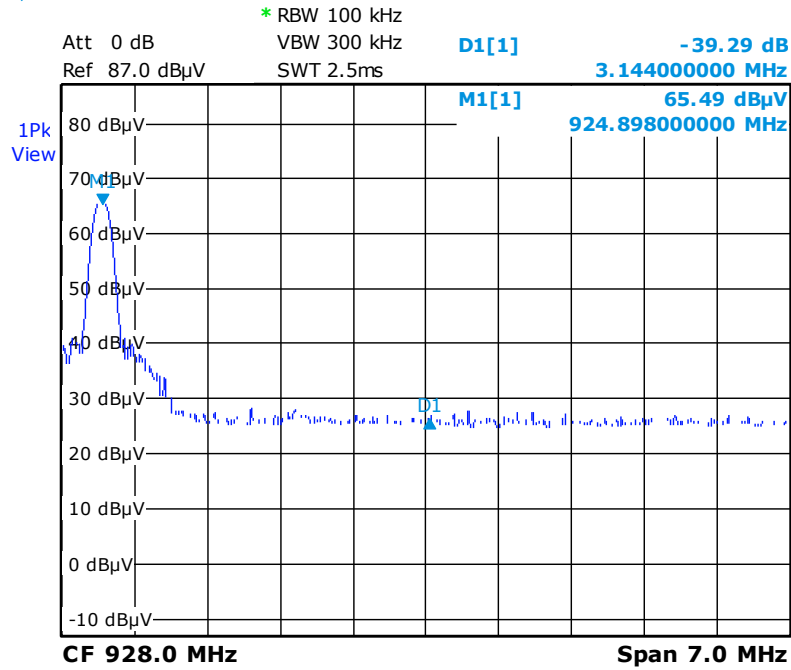

5.5 Time of Occupancy

1. Conducted Measurement
 EUT was set for low, mid, high channel with modulated mode and highest RF output power.
 The spectrum analyzer was connected to the antenna terminal.
2. Conducted Emissions Measurement Uncertainty
 All test measurements carried out are traceable to national standards. The uncertainty of the measurement at a confidence level of approximately 95% (in the case where distributions are normal), with a coverage factor of 2, in the range 30MHz – 20GHz is ± 1.5 dB.
3. Environmental Conditions

Temperature	21°C
Relative Humidity	55%
Atmospheric Pressure	1019mbar
4. Test Date : Nov 10th- Nov 23th, 2012
 Tested By : Jason Zhang

Standard Requirement: 47 CFR §15.247(f)

The frequency hopping operation of the hybrid system, with the direct sequence or digital modulation operation turned off, shall have an average time of occupancy on any frequency not to exceed 0.4 seconds within a time period in seconds equal to the number of hopping frequencies employed multiplied by 0.4.

Procedures: The Time of Occupancy measurement was taken conducted using a spectrum analyzer.

Calculation: Dwell Time equals to the number of hopping frequencies in each channel in $0.4 \times (\text{number of Channel}) = 2$ seconds multiply by the time of occupancy in each hopping frequency.

Test Result: Pass

Channel	Channel Frequency (MHz)	Dwell Time (sec)	Limit (sec)
Low	904.861	0.024	0.4
Mid	918.869	0.024	0.4
High	924.873	0.023	0.4

Low Channel

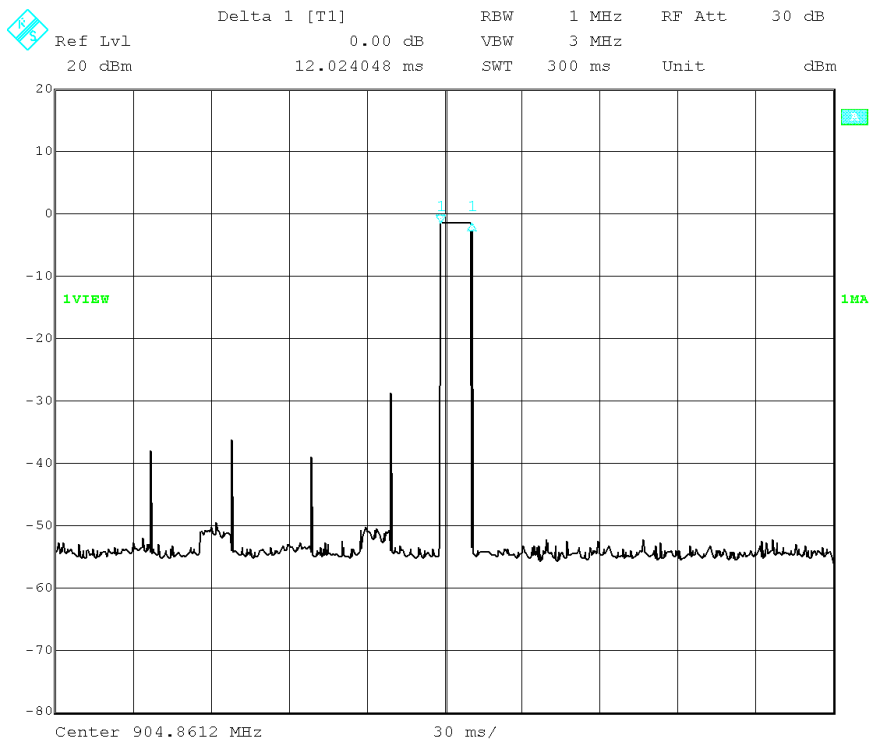
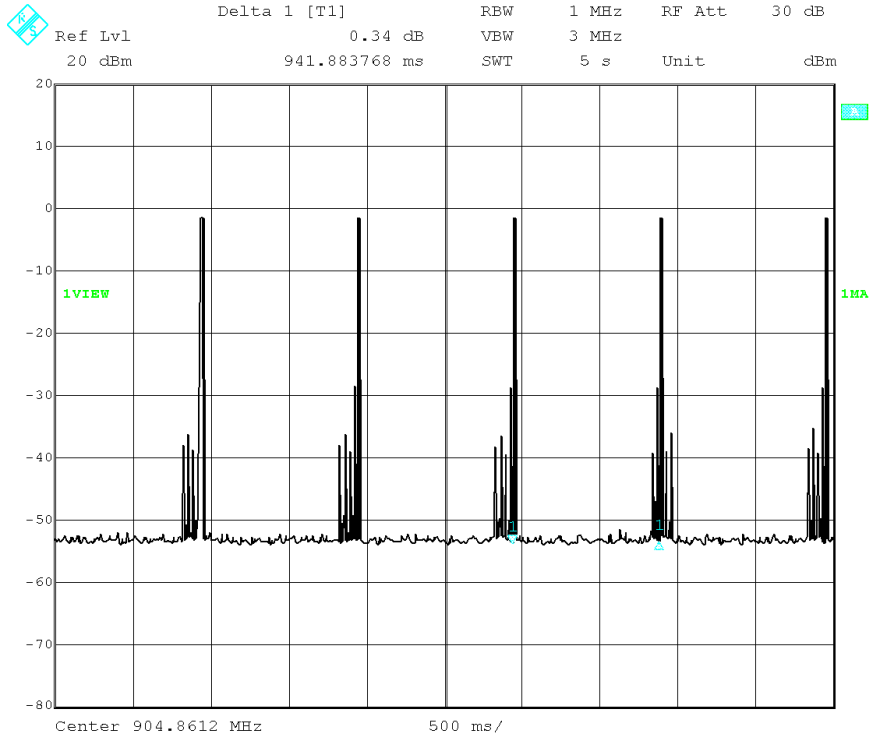

Mid Channel

	Delta 1 [T1]	RBW	1 MHz	RF Att	30 dB
Ref Lvl	-0.01 dB	VBW	3 MHz		
20 dBm	971.943888 ms	SWT	5 s	Unit	dBm

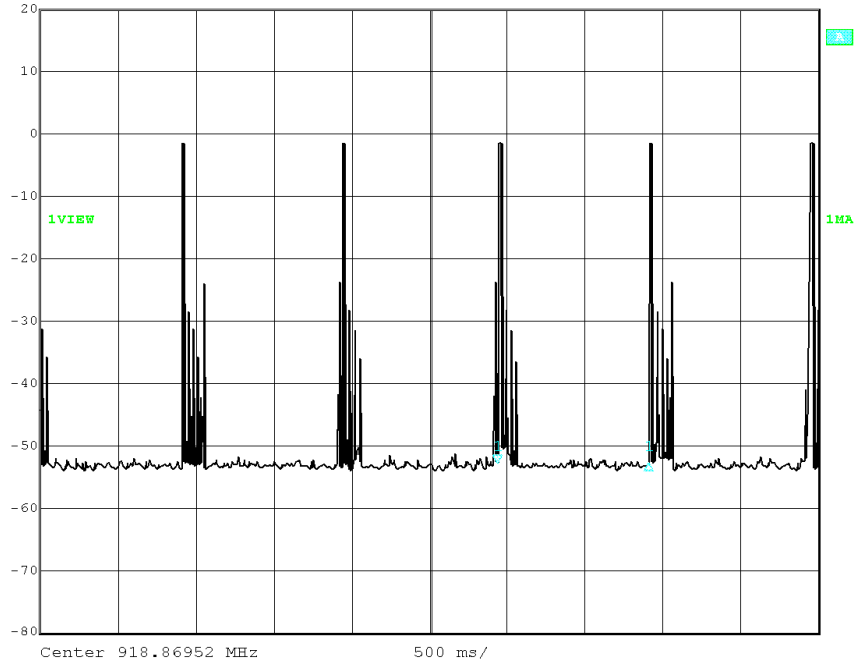

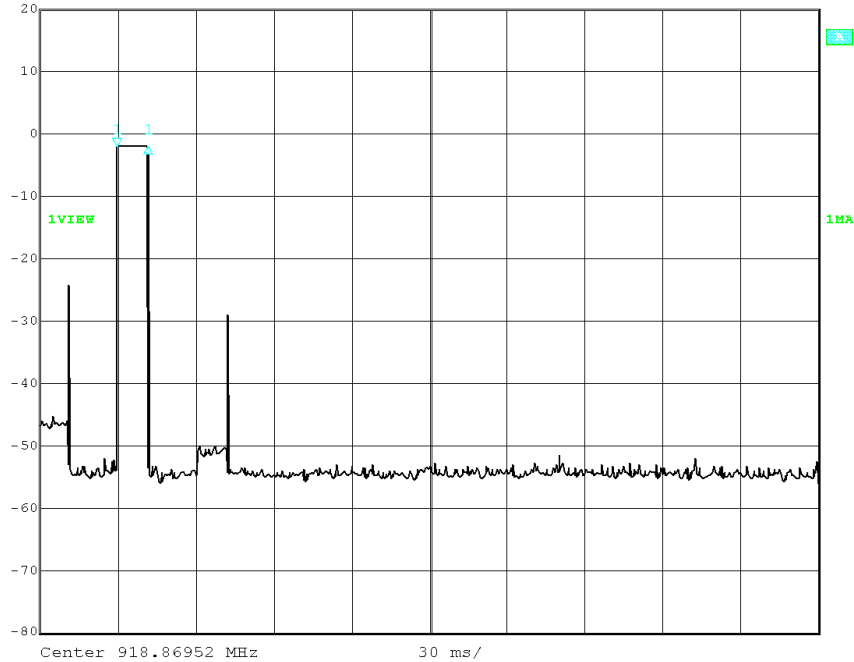

	Delta 1 [T1]	RBW	1 MHz	RF Att	30 dB
Ref Lvl	0.00 dB	VBW	3 MHz		
20 dBm	12.024048 ms	SWT	300 ms	Unit	dBm

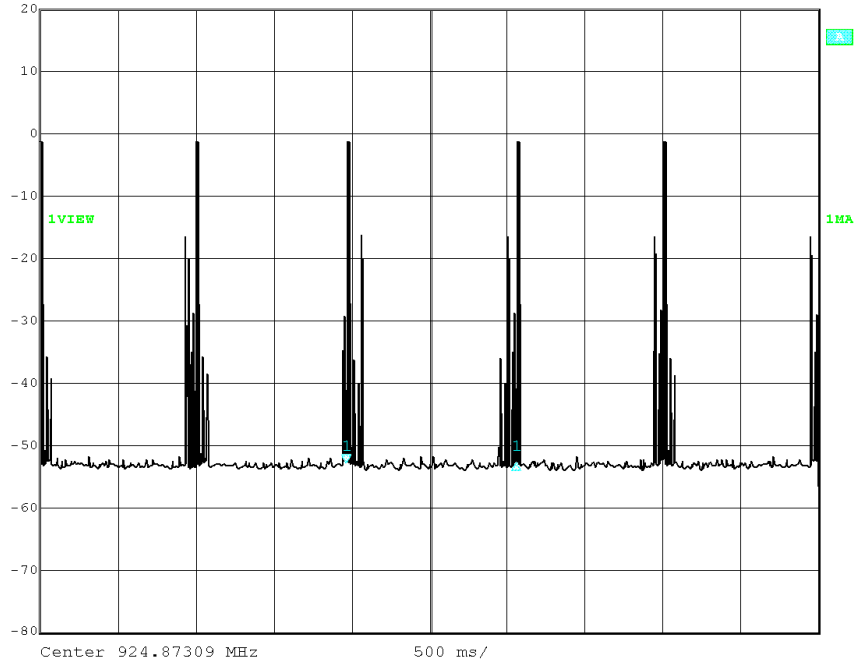

High Channel

	Delta 1 [T1]	RBW	1 MHz	RF Att	30 dB
Ref Lvl	-0.20 dB	VBW	3 MHz	Unit	dBm
20 dBm	1.092184 s	SWT	5 s		



	Delta 1 [T1]	RBW	1 MHz	RF Att	30 dB
Ref Lvl	-0.04 dB	VBW	3 MHz	Unit	dBm
20 dBm	11.422846 ms	SWT	300 ms		

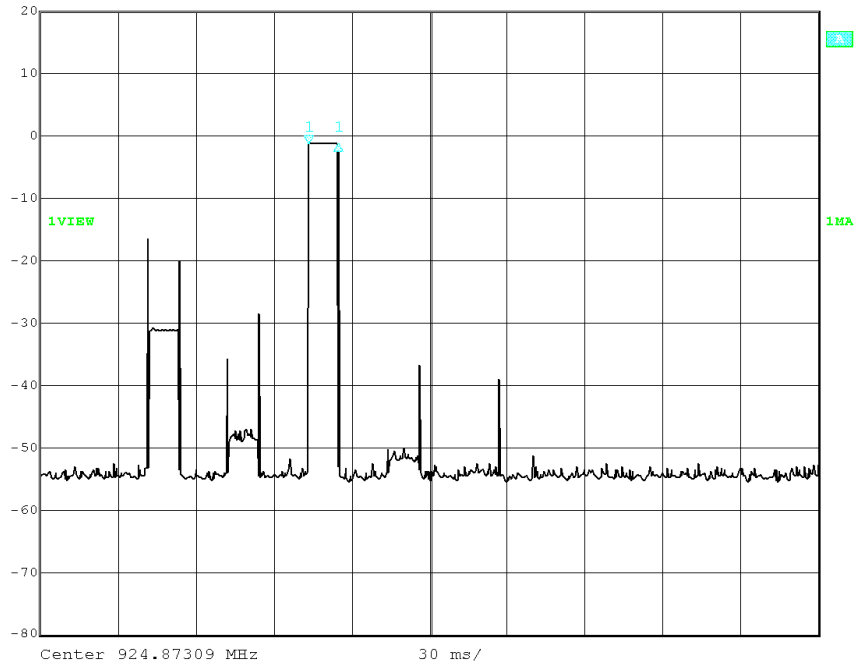

5.6 Peak Output Power

1. Conducted Measurement
EUT was set for low, mid, high channel with modulated mode and highest RF output power.
The spectrum analyzer was connected to the antenna terminal.
2. Conducted Emissions Measurement Uncertainty
All test measurements carried out are traceable to national standards. The uncertainty of the measurement at a confidence level of approximately 95% (in the case where distributions are normal), with a coverage factor of 2, in the range 30MHz – 40GHz is ± 1.5 dB.
3. Environmental Conditions

Temperature	21°C
Relative Humidity	55%
Atmospheric Pressure	1019mbar
4. Test Date : Nov 10th- Nov 23th, 2012
Tested By : Jason Zhang

Standard Requirement: 47 CFR §15.247(b)

Procedures: The peak output power was measured from 3 meter distance using a spectrum analyzer at low, mid, and hi channels. Peak detector was set to measure the power output. The power is converted from Field strength dBuV/m to EIRP dBm.

Note: For frequency hopping systems operating in the 902–928 MHz band: 1 watt for systems employing at least 50 hopping channels; and, 0.25 watts for systems employing less than 50 hopping channels, but at least 25 hopping channels, as permitted under paragraph (a)(1)(i) of this section.

Test Result: Pass

Measured distance 3 meter

Channel	Channel Frequency (MHz)	Measured Field Strength (dBuV)	Correction Factor (dB)	Corrected field strength	EIRP (dBm)	Antenna Gain (dBi)	Peak Output Power(dBm)	Peak Output Power Limit (dBm)
Low	904.861	70.48	25.99	96.47	1.17	-1	2.17	30
Mid	918.869	72.48	25.35	97.83	2.53	-1	3.53	30
High	924.873	71.53	25.39	96.92	1.62	-1	2.62	30

Note: EIRP(output)=Measured Field Strength + Correction Factor – 95.3dB

Output Power Low Channel

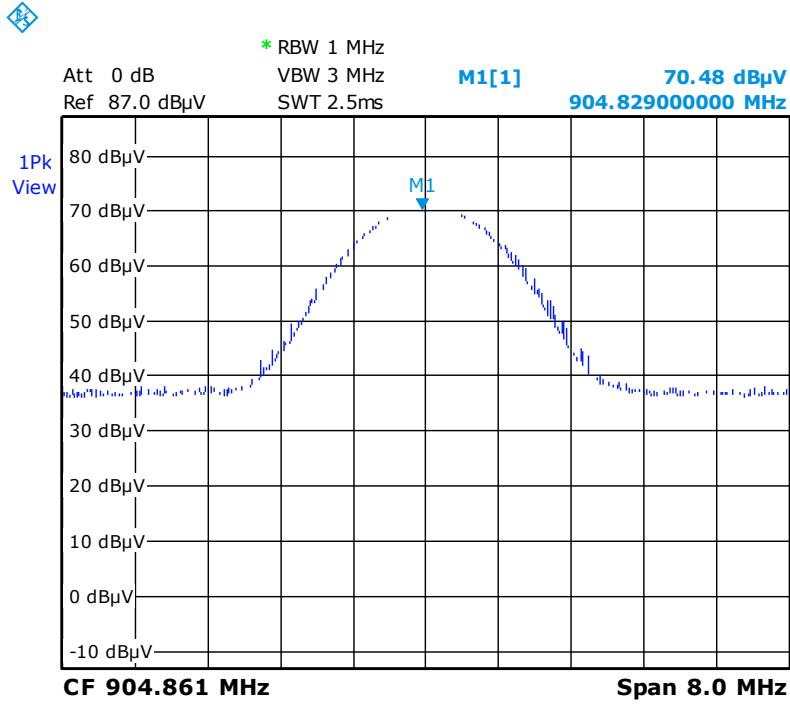

Date: 15.NOV.2012 23:40:02

Output Power Mid Channel

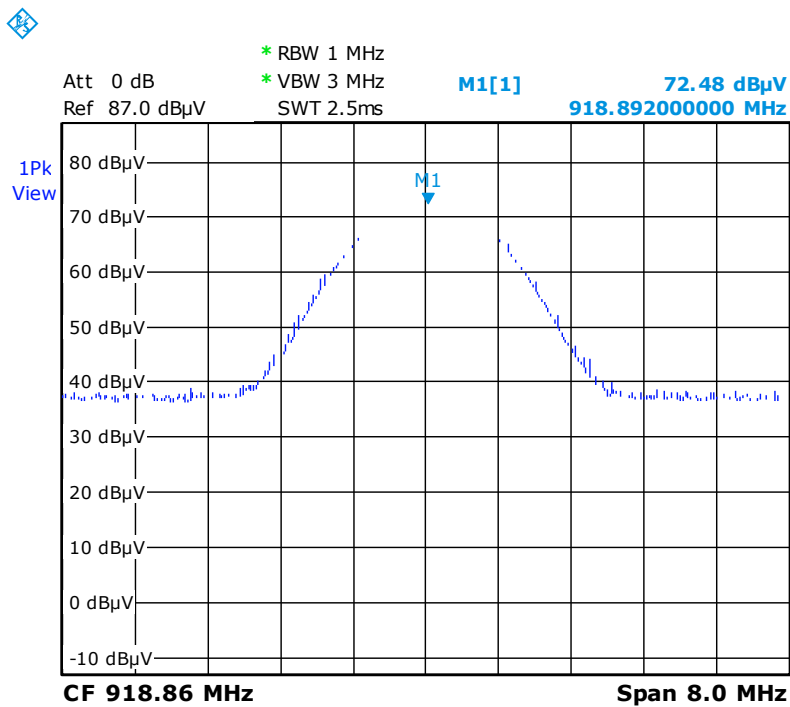

Date: 15.NOV.2012 23:28:01

Output Power High Channel

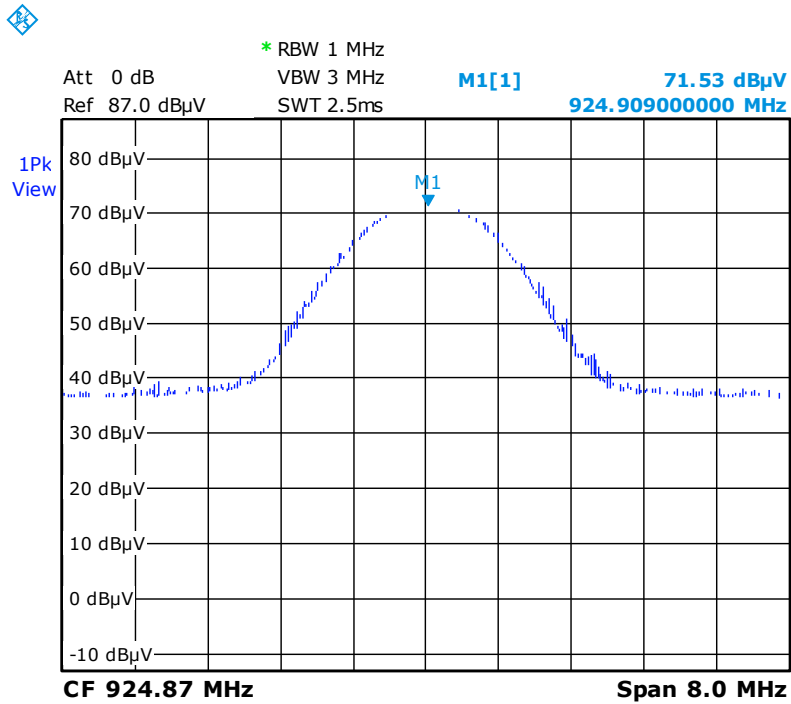

Date: 15.NOV.2012 23:34:01

5.7 Peak Power Spectral Density

1. Conducted Measurement
 EUT was set for low, mid, high channel with modulated mode and highest RF output power.
 The spectrum analyzer was connected to the antenna terminal. RBW = VBW = 3 KHz
2. Environmental Conditions

Temperature	22°C
Relative Humidity	50%
Atmospheric Pressure	1019mbar

Test Date : Nov 10th- Nov 23th, 2012
 Tested By : Jason Zhang

Standard Requirement:

Per FCC rule §15.247(e), the power spectral density shall not be greater than 8 dBm in any 3 KHz band.

Test Result: Pass

Measured distance 3 meter

Channel	Channel Frequency (MHz)	Measured Field Strength (dBuV)	Correction Factor (dB)	Corrected field strength	bandwidth correction factor(dB)	PPSD (dBm/3 kHz)	Limit (dBm/3 kHz)
Low	904.861	70.42	25.99	96.41	-15.2	-14.09	8
Mid	918.869	72.33	25.35	97.68	-15.2	-12.82	8
Hi	924.873	71.44	25.39	96.83	-15.2	-13.67	8

Note: PSD=Measured Field Strength + Correction Factor + bandwidth Correction factor – 95.3dBm

Bandwidth correction factor (BWCF) where BWCF = $10\log(3\text{ kHz}/100\text{kHz}) = -15.2\text{ dB}$.

Low Channel

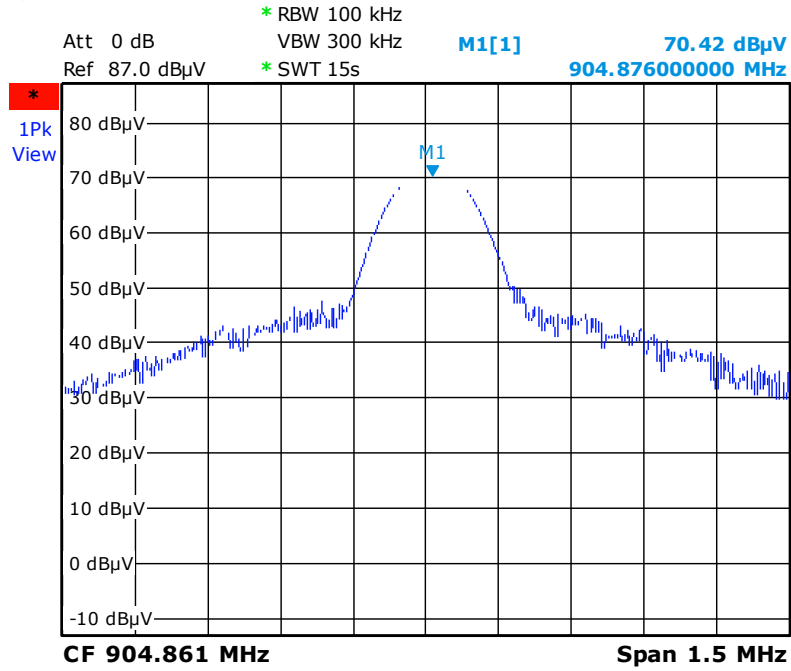

Date: 15.NOV.2012 23:40:58

Middle Channel

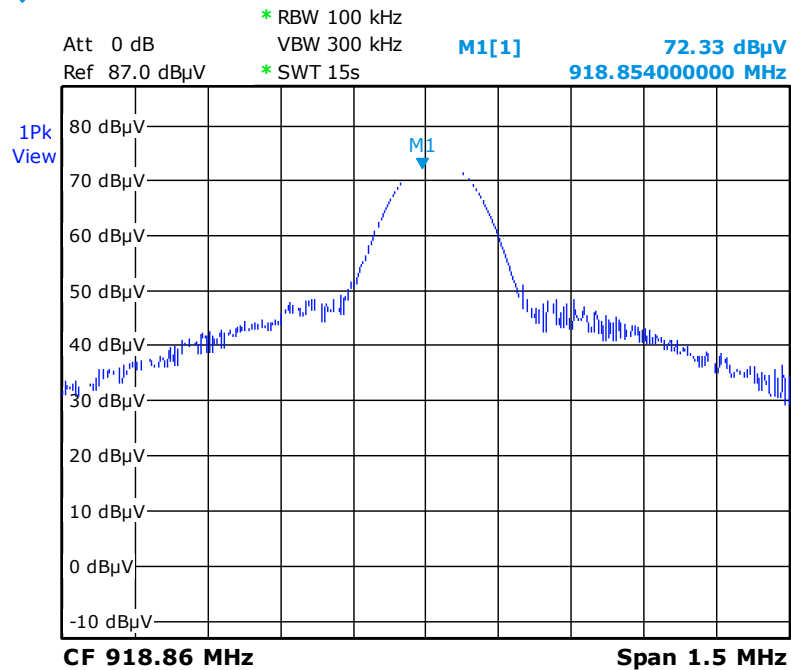

Date: 15.NOV.2012 23:30:48

High Channel

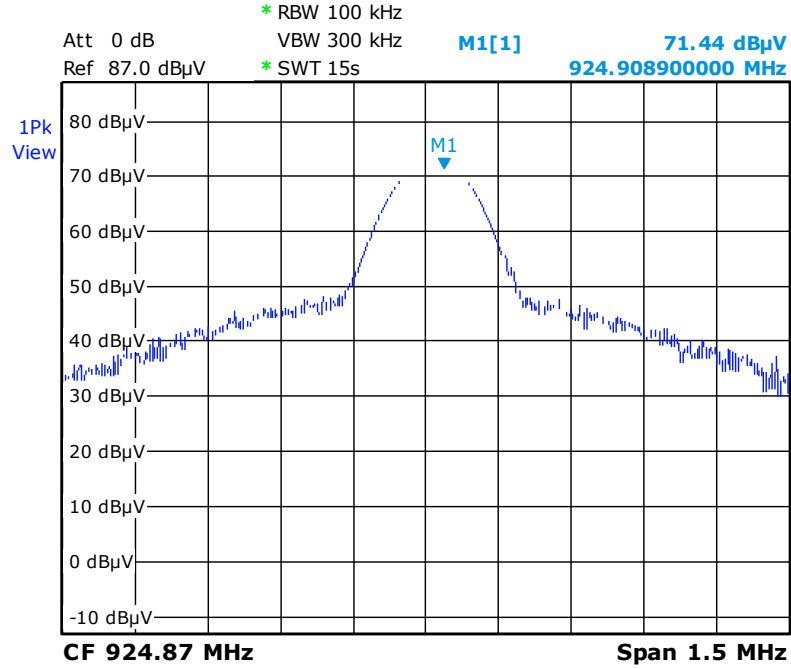

Date: 15.NOV.2012 23:32:57

5.8 Radiated Spurious Emission < 1GHz

1. All possible modes of operation were investigated. Only the 6 worst case emissions measured, using the correct CISPR detectors, are reported. All other emissions were relatively insignificant.
2. A "-ve" margin indicates a PASS as it refers to the margin present below the limit line at the particular frequency.
3. Radiated Emissions Measurement Uncertainty
All test measurements carried out are traceable to national standards. The uncertainty of the measurement at a confidence level of approximately 95% (in the case where distributions are normal), with a coverage factor of 2, in the range 30MHz – 1GHz (QP only @ 3m & 10m) is +5.6dB/-4.5dB (for EUTs < 0.5m X 0.5m X 0.5m).
4. Environmental Conditions

Temperature	20°C
Relative Humidity	50%
Atmospheric Pressure	1019mbar

Test Date : Nov 10th- Nov 23th, 2012
 Tested By : Jason Zhang

Standard Requirement : 47 CFR §15.247(c)

Procedures: Radiated emissions were measured according to ANSI C63.4. The EUT was set to transmit at the highest output power. The EUT was set to transmit at mid channel. Note that setting the channel other than mid, the spurious emissions are the same.

The limit is converted from microvolts/meter to decibel microvolts/meter.

Sample Calculation: Corrected Amplitude = Raw Amplitude (dBμV/m) + ACF(dB) + Cable Loss(dB)

Test Result: Pass

Emission Test Result (Below 1GHz)

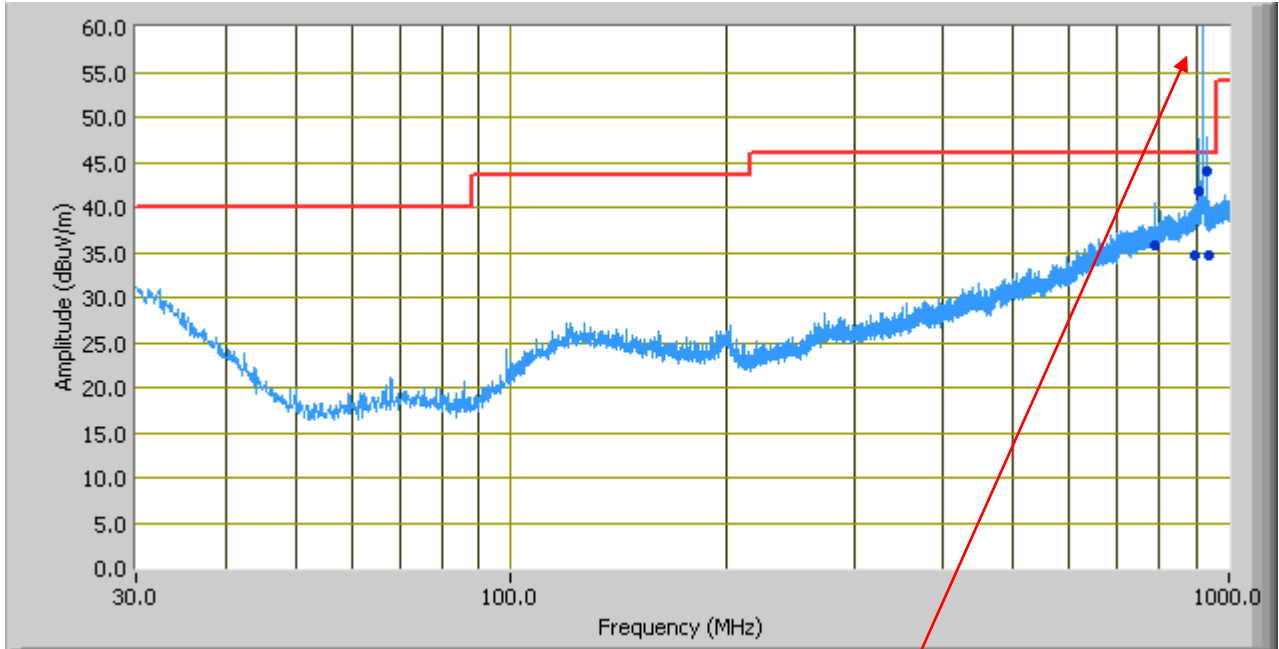

Limit

EUT operating frequency

30MHz ~1000MHz @ 3m @ Class B

Frequency (MHz)	Quasi-Peak (dBμV/m) @ 3m	Turntable position (deg)	Polarity	Antenna height (cm)	Limit (dBμV/m)	Margin (dB)
790.05	35.76	249.00	V	281.00	46.00	-10.24
896.91	34.74	106.00	V	251.00	46.00	-11.26
905.94	41.73	275.00	H	207.00	46.00	-4.27
918.89	96.95	269.00	H	207.00	46.00	50.95
931.93	43.94	263.00	H	200.00	46.00	-2.06
934.96	34.64	68.00	H	244.00	46.00	-11.36

5.9 Radiated Spurious Emissions > 1GHz

1. All possible modes of operation were investigated. Only the 6 worst case emissions measured, using the correct CISPR detectors, are reported. All other emissions were relatively insignificant.
2. A "-ve" margin indicates a PASS as it refers to the margin present below the limit line at the particular frequency.
3. Radiated Emissions Measurement Uncertainty
All test measurements carried out are traceable to national standards. The uncertainty of the measurement at a confidence level of approximately 95% (in the case where distributions are normal), with a coverage factor of 2, in the range 1GHz – 20GH is +5.6dB/-4.5dB (for EUTs < 0.5m X 0.5m X 0.5m).
4. Environmental Conditions

Temperature	20°C
Relative Humidity	50%
Atmospheric Pressure	1019mbar

Test Date : Nov 10th- Nov 23th, 2012
 Tested By : Jason Zhang

Standard Requirement : 47 CFR §15.247(d)

Procedures: Equipment was setup in a semi-anechoic chamber. For measurements above 1 GHz an average measurement was taken with a 10Hz video bandwidth. The EUT was tested at low, mid and high with the highest output power. Investigated up to 10th harmonics of the operating frequency.

Sample Calculation:

EUT Field Strength = Raw Amplitude(dBμV/m) – Amplifier Gain(dB) + Antenna Factor(dB) + Cable Loss(dB) + Filter Attenuation(dB, if used)

Test Result: Pass

904.861MHz @ 3 Meter

Frequency (GHz)	Reading (dBuV/m)	Direction (Degree)	Height (m)	Polar	Antenna Loss (dB)	Cable loss (dB)	Amplifier (dB)	Corrected Reading (dBuV/m)	Limit (dBuV/m)	Margin (dB)	
1.809	48.1	217	222	h	25.7	2.16	31.98	43.98	74	-30.02	Peak
1.809	44.38	115	135	v	25.7	2.16	31.98	40.26	74	-33.74	Peak
1.809	42.53	217	222	h	25.7	2.16	31.98	38.41	54	-15.59	Ave
1.809	39.17	115	135	v	25.7	2.16	31.98	35.05	54	-18.95	Ave
2.714	45.6	164	100	h	28.8	2.72	32.08	45.04	74	-28.96	Peak
2.714	43.13	271	167	v	28.8	2.72	32.08	42.57	74	-31.43	Peak
2.714	40.03	164	100	h	28.8	2.72	32.08	39.47	54	-14.53	Ave
2.714	37.17	271	167	v	28.8	2.72	32.08	36.61	54	-17.39	Ave
5.429	40.21	48	128	h	32.9	4.32	32.55	44.88	74	-29.12	Peak
5.429	42.27	246	100	v	32.9	4.32	32.55	46.94	74	-27.06	Peak
5.429	38.17	48	128	h	32.9	4.32	32.55	42.84	54	-11.16	Ave
5.429	40.07	246	100	v	32.9	4.32	32.55	44.74	54	-9.26	Ave

Note: Emission was scanned up to 10GHz; no emissions were detected above the noise floor which was at least 20dB below the specification limit.

918.869MHz @ 3Meter

Frequency (GHz)	Reading (dBuV/m)	Direction (Degree)	Height (m)	Polar	Antenna Loss (dB)	Cable loss (dB)	Amplifier (dB)	Corrected Reading (dBuV/m)	Limit (dBuV/m)	Margin (dB)	Frequency (GHz)
1.837	53.24	153	109	h	25.7	2.16	31.98	49.12	74	-24.88	Peak
1.837	50.75	153	171	v	25.7	2.16	31.98	46.63	74	-27.37	Peak
1.837	49.15	153	109	h	25.7	2.16	31.98	45.03	54	-8.97	Ave
1.837	46.29	153	171	v	25.7	2.16	31.98	42.17	54	-11.83	Ave
5.513	40.21	110	200	h	33.4	4.56	32.48	45.69	74	-28.31	Peak
5.513	38.27	171	155	v	33.4	4.56	32.48	43.75	74	-30.25	Peak
5.513	38.17	110	200	h	33.4	4.56	32.48	43.65	54	-10.35	Ave
5.513	36.07	171	155	v	33.4	4.56	32.48	41.55	54	-12.45	Ave
7.113	40.24	339	101	h	35.1	5.22	32.39	48.17	74	-25.83	Peak
7.113	42.75	259	298	v	35.1	5.22	32.39	50.68	74	-23.32	Peak
7.113	36.1	339	101	h	35.1	5.22	32.39	44.03	54	-9.97	Ave
7.113	38.29	259	298	v	35.1	5.22	32.39	46.22	54	-7.78	Ave

Note: Emission was scanned up to 10GHz; no emissions were detected above the noise floor which was at least 20dB below the specification limit.

A

SIEMIC, INC.

Accessing global markets

Title: RF Test Report of RF Switched Outlet
 Model: ARPS15RF2W4 / ARPS15RF2M4
 To: FCC 15.247:2011, RSS-210 Issue 8:2010

Serial# RF_SL12062002-LHS-007_FCC-IC
 Issue Date Nov 27th, 2012
 Page 36 of 74
 www.sieminc.com

924.873MHz @ 3Meter

Frequency (GHz)	Reading (dBuV/m)	Direction (Degree)	Height (m)	Polar	Antenna Loss (dB)	Cable loss (dB)	Amplifier (dB)	Corrected Reading (dBuV/m)	Limit (dBuV/m)	Margin (dB)	Frequency (GHz)
1.849	47.86	0	100	h	25.7	2.16	31.98	43.74	74	-30.26	Peak
1.849	49.17	195	102	v	25.7	2.16	31.98	45.05	74	-28.95	Peak
1.849	42.17	0	100	h	25.7	2.16	31.98	38.05	54	-15.95	Ave
1.849	44.05	195	102	v	25.7	2.16	31.98	39.93	54	-14.07	Ave
2.775	44	24	147	h	28.8	2.72	32.08	43.44	74	-30.56	Peak
2.775	41.73	245	137	v	28.8	2.72	32.08	41.17	74	-32.83	Peak
2.775	41.48	24	147	h	28.8	2.72	32.08	40.92	54	-13.08	Ave
2.775	38.48	245	137	v	28.8	2.72	32.08	37.92	54	-16.08	Ave
5.549	40.21	15	118	h	33.4	4.56	32.48	45.69	74	-28.31	Peak
5.549	38.51	120	175	v	33.4	4.56	32.48	43.99	74	-30.01	Peak
5.549	38.37	15	118	h	33.4	4.56	32.48	43.85	54	-10.15	Ave
5.549	36.01	120	175	v	33.4	4.56	32.48	41.49	54	-12.51	Ave

Note: Emission was scanned up to 10GHz; no emissions were detected above the noise floor which was at least 20dB below the specification limit.

A

SIEMIC, INC.
 Accessing global markets

 Title: RF Test Report of RF Switched Outlet
 Model: ARPS15RF2W4 / ARPS15RF2M4
 To: FCC 15.247.2011, RSS-210 Issue 8:2010

 Serial# RF_SL12062002-LHS-007_FCC-IC
 Issue Date Nov 27th, 2012
 Page 37 of 74
 www.sieminc.com

Annex A. TEST INSTRUMENT & METHOD

Annex A.i. TEST INSTRUMENTATION & GENERAL PROCEDURES

Instrument	Model	Serial #	Calibration Date	Calibration Due	Calibrate Cycle
CONDUCTED EMISSIONS					
R & S Receiver	ESIB 40	100179	4/20/2012	4/20/2013	1year
R&S LISN	ESH2-Z5	861741/013	05/18/2012	05/18/2013	1year
CHASE LISN	MN2050B	1018	05/18/2012	05/18/2013	1year
Sekonic Hygro Hermograph	ST-50	HE01-000092	05/25/2012	05/25/2013	1year
Radiated Emissions					
R & S Receiver	ESIB 40	100179	4/20/2012	4/20/2013	1year
Sunol Sciences, Inc. antenna (30MHz~2GHz)	JB1	A030702	2/9/2012	2/9/2013	1year
10 Meters SAC	10M	N/A	6/5/2012	6/5/2013	1year
Sekonic Hygro Hermograph	ST-50	HE01-000092	05/25/2012	05/25/2013	1year
Spectrum Analyzer	8564E	3738A00962	05/19/2012	05/19/2013	1year
Antenna(1 ~18GHz)	3115	10SL0059	4/26/2012	4/26/2013	1year
Pre-Amplifier(1 ~ 26GHz)	8449	3008A00715	5/17/2012	5/17/2013	1year
Signal Analyzer	FSIQ7	825555/013	5/10/2012	5/10/2013	1year

Note: Functional Verification

Annex A.ii. CONDUCTED EMISSIONS TEST DESCRIPTION

Test Set-up

1. The EUT and supporting equipment were set up in accordance with the requirements of the standard on top of a 1.5m x 1m x 0.8m high, non-metallic table, as shown in [Annex B](#).
2. The power supply for the EUT was fed through a 50Ω/50μH EUT LISN, connected to filtered mains.
3. The RF OUT of the EUT LISN was connected to the EMI test receiver via a low-loss coaxial cable.
4. All other supporting equipments were powered separately from another main supply.

Test Method

1. The EUT was switched on and allowed to warm up to its normal operating condition.
2. A scan was made on the NEUTRAL line (for AC mains) or Earth line (for DC power) over the required frequency range using an EMI test receiver.
3. High peaks, relative to the limit line, were then selected.
4. The EMI test receiver was then tuned to the selected frequencies and the necessary measurements made with a receiver bandwidth setting of 10 KHz. For FCC tests, only Quasi-peak measurements were made; while for CISPR/EN tests, both Quasi-peak and Average measurements were made.
5. Steps 2 to 4 were then repeated for the LIVE line (for AC mains) or DC line (for DC power).

Description of Conducted Emission Program

This EMC Measurement software run LabView automation software and offers a common user interface for electromagnetic interference (EMI) measurements. This software is a modern and powerful tool for controlling and monitoring EMI test receivers and EMC test systems. It guarantees reliable collection, evaluation, and documentation of measurement results. Basically, this program will run a pre-scan measurement before it proceeds with the final measurement. The pre-scan routine will run the common scan range from 15 kHz to 30 MHz; the program will first start a peak and average scan on selectable measurement time and step size. After the program complete the pre-scan, this program will perform the Quasi Peak and Average measurement, based on the pre-scan peak data reduction result.

Sample Calculation Example

At 20 MHz	limit = 250 μV = 47.96 dBμV
Transducer factor of LISN, pulse limiter & cable loss at 20 MHz = 11.20 dB	
Q-P reading obtained directly from EMI Receiver = 40.00 dBμV (Calibrated for system losses)	
Therefore, Q-P margin = 47.96 – 40.00 = 7.96	i.e. 7.96 dB below limit

Annex A. iii RADIATED EMISSIONS TEST DESCRIPTION

EUT Characterisation

EUT characterisation, over the frequency range from 30MHz to 10th Harmonic, was done in order to minimise radiated emissions testing time while still maintaining high confidence in the test results.

The EUT was placed in the chamber, at a height of about 0.8m on a turntable. Its radiated emissions frequency profile was observed, using a spectrum analyzer /receiver with the appropriate broadband antenna placed 3m away from the EUT. Radiated emissions from the EUT were maximised by rotating the turntable manually, changing the antenna polarisation and manipulating the EUT cables while observing the frequency profile on the spectrum analyzer / receiver. Frequency points at which maximum emissions occurred, clock frequencies and operating frequencies were then noted for the formal radiated emissions test at the Open Area Test Site (OATS).

Test Set-up

1. The EUT and supporting equipment were set up in accordance with the requirements of the standard on top of a 1.5m X 1.0m X 0.8m high, non-metallic table.
2. The filtered power supply for the EUT and supporting equipment were tapped from the appropriate power sockets located on the turntable.
3. The relevant broadband antenna was set at the required test distance away from the EUT and supporting equipment boundary.

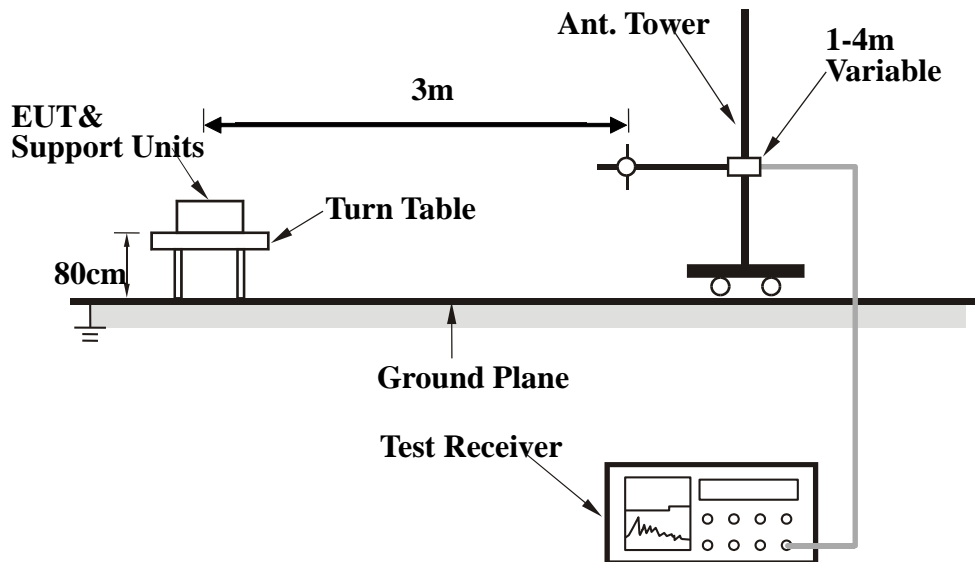

Test Method

The following procedure was performed to determine the maximum emission axis of EUT:

1. With the receiving antenna is H polarization, rotate the EUT in turns with three orthogonal axes to determine the axis of maximum emission.
2. With the receiving antenna is V polarization, rotate the EUT in turns with three orthogonal axes to determine the axis of maximum emission.
3. Compare the results derived from above two steps. So, the axis of maximum emission from EUT was determined and the configuration was used to perform the final measurement.

Final Radiated Emission Measurement

1. Setup the configuration according to figure 1. Turn on EUT and make sure that it is in normal function.
2. For emission frequencies measured below 1 GHz, a pre-scan is performed in a shielded chamber to determine the accurate frequencies of higher emissions will be checked on a open test site. As the same purpose, for emission frequencies measured above 1 GHz, a pre-scan also be performed with a 1 meter measuring distance before final test.
3. For emission frequencies measured below and above 1 GHz, set the spectrum analyzer on a 100 kHz and 1 MHz resolution bandwidth respectively for each frequency measured in step 2.
4. The search antenna is to be raised and lowered over a range from 1 to 4 meters in horizontally polarized orientation. Position the highness when the highest value is indicated on spectrum analyzer, then change the orientation of EUT on test table over a range from 0 ° to 360 ° with a speed as slow as possible, and keep the azimuth that highest emission is indicated on the spectrum analyzer. Vary the antenna position again and record the highest value as a final reading.
5. Repeat step 4 until all frequencies need to be measured were complete.
6. Repeat step 5 with search antenna in vertical polarized orientations.

During the radiated emission test, the Spectrum Analyzer was set with the following configurations:

Frequency Band (MHz)	Function	Resolution bandwidth	Video Bandwidth
30 to 1000	Peak	100 kHz	100 kHz
Above 1000	Peak	1 MHz	1 MHz
	Average	1 MHz	10 Hz

Description of Radiated Emission Program

This EMC Measurement software run LabView automation software and offers a common user interface for electromagnetic interference (EMI) measurements. This software is a modern and powerful tool for controlling and monitoring EMI test receivers and EMC test systems. It guarantees reliable collection, evaluation, and documentation of measurement results. Basically, this program will run a pre-scan measurement before it proceeds with the final measurement. The pre-scan routine will run the scan on four different antenna heights, 2 antenna polarity, and 360 degrees table rotation. For example, the program was set to run 30 MHz to 1 GHz scan; the program will first start from a meter antenna height and divide the 30 MHz to 1 GHz into 10 separate parts of maximum hold sweeps. Each parts of maximum hold sweep, the program will collect the data from 0 degree to 360 degrees table rotation. After the program complete the 1m scan, the antenna continues to rise to 2m and continue the scan. The step will repeated for all specified antenna height and polarity. This program will perform the Quasi Peak measurement after the signal maximization process and pre-scan routine. The final measurement will be based on the pre-scan data reduction result.

Sample Calculation Example

The field strength is calculated by adding the Antenna Factor and Cable Factor, and subtracting the Amplifier Gain (if any) from the measured reading. For the limit is employed average value, therefore the peak value can be transferred to average value by subtracting the duty factor. The basic equation with a sample calculation is as follows:

$$\text{Peak} = \text{Reading} + \text{Corrected Factor}$$

where

$$\text{Corr. Factor} = \text{Antenna Factor} + \text{Cable Factor} - \text{Amplifier Gain (if any)}$$

And the average value is

$$\text{Average} = \text{Peak Value} + \text{Duty Factor or}$$

$$\text{Set RBW} = 1\text{MHz, VBW} = 10\text{Hz.}$$

Note:

If the measured frequencies are fall in the restricted frequency band, the limit employed must be quasi peak value when frequencies are below or equal to 1 GHz. And the measuring instrument is set to quasi peak detector function.

A



SIEMIC, INC.
Accessing global markets

Title:	RF Test Report of RF Switched Outlet	Serial#	RF_SL12062002-LHS-007_FCC-IC
Model:	ARPS15RF2W4 / ARPS15RF2M4	Issue Date	Nov 27th, 2012
To:	FCC 15.247:2011, RSS-210 Issue 8:2010	Page	41 of 74
			www.siemac.com

Annex B. EUT AND TEST SETUP PHOTOGRAPHS

Please see the attachment

Annex C. TEST SETUP AND SUPPORTING EQUIPMENT**EUT TEST CONDITIONS****Annex C. i. SUPPORTING EQUIPMENT DESCRIPTION**

The following is a description of supporting equipment and details of cables used with the EUT.

Equipment Description (Including Brand Name)	Model & Serial Number	Cable Description (List Length, Type & Purpose)
None	None	None

Block Configuration Diagram for Radiated Emission

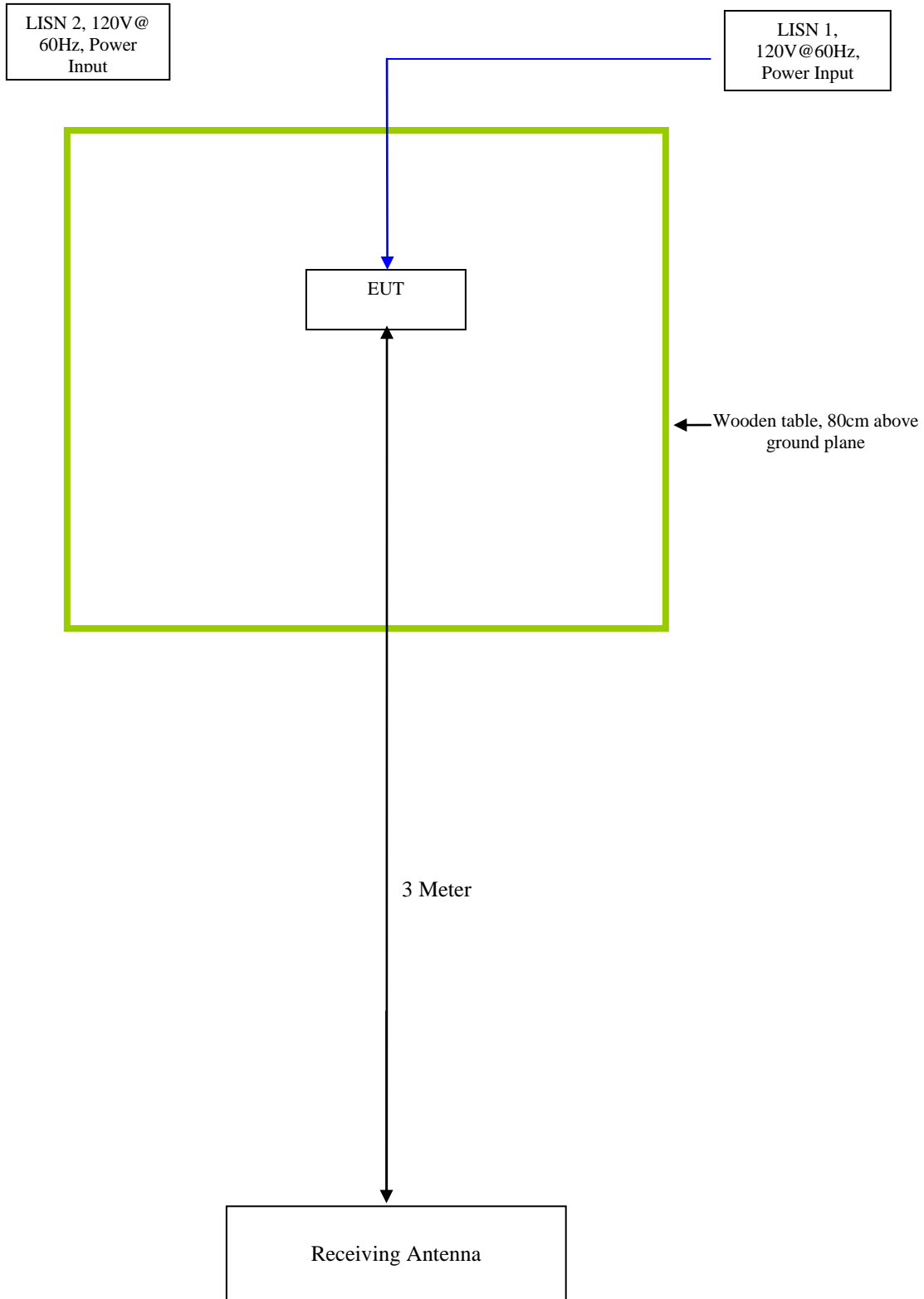

Block Configuration Diagram for Conducted Emission

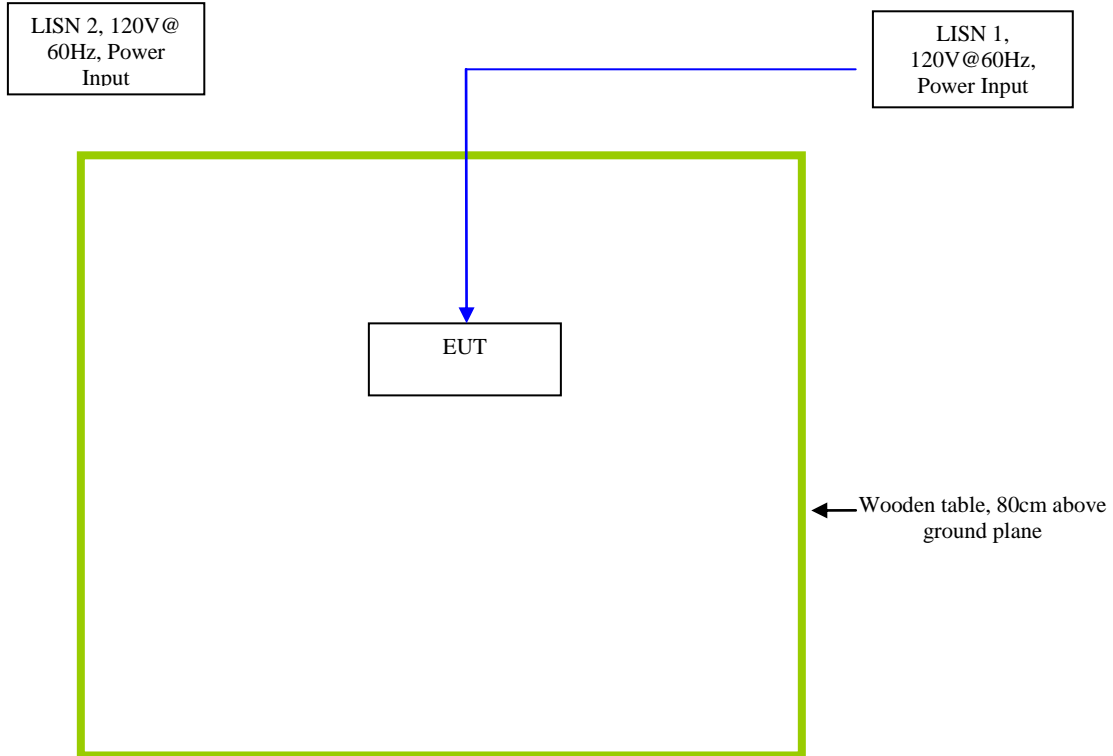

Annex C.ii. EUT OPERATING CONDITIONS

The following is the description of how the EUT is exercised during testing.

Test	Description Of Operation
Emissions Testing Others Testing	EUT was configured to continuously transmit at full power.

A

Annex D. USER MANUAL, BLOCK & CIRCUIT DIAGRAM

Please see attachment

A

SIEMIC, INC.

Accessing global markets

Title: RF Test Report of RF Switched Outlet
Model: ARPS15RF2W4 / ARPS15RF2M4
To: FCC 15.247:2011, RSS-210 Issue 8:2010

Serial# RF_SL12062002-LHS-007_FCC-IC
Issue Date Nov 27th, 2012
Page 47 of 74
www.sieminc.com

Annex E SIEMIC ACCREDITATION

SIEMIC ACCREDITATION DETAILS: A2LA 17025 & ISO Guide 65 : 2742.01 , 2742.2



American Association for Laboratory Accreditation

Accredited Laboratory

A2LA has accredited

SIEMIC, INC.

Milpitas, CA

for technical competence in the field of

Electrical Testing

This laboratory is accredited in accordance with the recognized International Standard ISO/IEC 17025:2005 *General Requirements for the Competence of Testing and Calibration Laboratories*. This accreditation demonstrates technical competence for a defined scope and the operation of a laboratory quality management system (refer to joint ISO-ILAC-IAF Communiqué dated 8 January 2009).

Presented this 19th day of September 2012.



President & CEO
For the Accreditation Council
Certificate Number 2742.01
Valid to September 30, 2014

For the tests or types of tests to which this accreditation applies, please refer to the laboratory's Electrical Scope of Accreditation.



American Association for Laboratory Accreditation

SCOPE OF ACCREDITATION TO ISO/IEC 17025:2005

SIEMIC, INC.
 dba SIEMIC LABORATORIES
 775 Montague Expressway
 Milpitas, CA 95035
 Mr. Leslie Bai Phone: 408 526 1188 Email: leslie.bai@siemic.com
 Mr. Snell Leong Phone: 408 526 1188 Email: snell.leong@siemic.com
www.siemic.com

ELECTRICAL

Valid to: September 30, 2014

Certificate Number: 2742.01

In recognition of the successful completion of the A2LA evaluation process, accreditation is granted to this laboratory to perform the following EMC, Product Safety, Radio and Telecommunication tests:

<u>Test Technology:</u>	<u>Test Method(s):</u>
EN & IEC – Emissions & Immunity	IEC/CISPR 11; EN 55011; IEC/CISPR 12; IEC/CISPR 20; EN 55020; IEC/CISPR 22; EN 55022; IEC/CISPR 24; EN 55024; EN 61000-6-1; EN 61000-6-2; EN 61000-6-3; EN 61000-6-4; EN 61204-3; EN 61326-1; EN 61326-2-1; EN 61326-2-2; EN 61326-2-3; EN 61326-2-4; EN 61326-2-5; EN 61000-3-2; EN 61000-3-3; EN 50081-1, EN 50081-2; EN 50082-1; IEC 61000-4-2; EN 61000-4-2; IEC 61000-4-3 (limited up to 2.7 GHz and 3V/m); EN 61000-4-3 (limited up to 2.7 GHz and 3V/m); IEC 61000-4-4; EN 61000-4-4; IEC 61000-4-5; EN 61000-4-5; IEC 61000-4-6; EN 61000-4-6; IEC 61000-4-8; EN 61000-4-8; IEC 61000-4-11; EN 61000-4-11; EN 50412-2-1; EN 50083-2; EN 50090-2-2; EN 50091-2; EN 50491-5-1; EN 50491-5-2; EN 50491-5-3; EN 50130-4; EN 50130-4 + A12; EN 12184; EN 55015; EN 61547; IEC 60601-1-2; CISPR 16-2-3

Peter Abney

(A2LA Cert. No. 2742.01) 09/19/2012

Page 1 of 8

<u>Test Technology:</u>	<u>Test Method(s):</u>
Korea – Emissions & Immunity	RRA Public Notification 2011-24; RRA Announce 2011-30; Annex 2 (KN 11); Annex 3 (KN 13); Annex 4 (KN 14-1); Annex 5 (KN 22); Annex 6 (KN 41); Annex 7 (KN 50); Annex 9 (KN 15); Annex 10 (KN 19); Annex 11 (KN 60); Annex 1-1 (KN 16-1-1); Annex 1-2 (KN 16-1-2); Annex 1-3 (KN 16-1-3); Annex 1-4 (KN 16-1-4); Annex 1-5 (KN 16-1-5); Annex 1-6 (KN 16-2-1); Annex 1-7 (KN 16-2-2); Annex 1-8 (KN 16-2-3); Annex 1-9 (KN 16-2-4); Annex 8-5 (KN 301-489-06); Annex 8-6 (KN 301-489-13); Annex 8-7 (KN 301-489-05); Annex 8-8 (KN 301-489-03); Annex 8-9 (KN 301-489-09); Annex 8-10 (KN 301-489-26); Annex 8-11 (KN 301-489-18); Annex 8-12 (KN 301-489-15); Annex 8-13 (KN 301-489-02); Annex 8-14 (KN 301-489-27); Annex 8-15 (KN 301-489-32); Annex 8-16 (KN 301-489-20); Annex 8-17 (KN 60945) RRA Public Notification 2011-25; RRA Announce 2011-31; Annex 1-1 (KN 61000-4-2); Annex 1-2 (KN 61000-4-3); Annex 1-3 (KN 61000-4-4); Annex 1-4 (KN 61000-4-5); Annex 1-5 (KN 61000-4-6); Annex 1-6 (KN 61000-4-8); Annex 1-7 (KN 61000-4-11); Annex 2 (KN 60601-1-2); Annex 3 (KN 20); Annex 4 (KN 14-2); Annex 5 (KN 24); Annex 6 (KN 41); Annex 7 (KN 51); Annex 8-1 (KN 301-489-01); Annex 8-2(KN 301-489-07); Annex 8-3 (KN 301-489-17); Annex 8-4(KN 301-489-24);
US / FCC - Emissions	FCC Method 47 CFR Part 18, FCC Report and Order ET Docket 98-153 (FCC 02-48); FCC Method 47 CFR Parts15, including Subpart G, using FCC Order 04-425; ANSI C63.4 (2003); ANSI C63.4 (2009); ANSI C63.10 (2009); ANSI C63.4 (2003) with FCC Method 47 CFR Part 11; ANSI C63.4 (2003) with FCC Method 47 CFR Part 15, Subpart E; ANSI C63.4 (2003) with FCC Method 47 CFR Part 15, Subpart C; ANSI C63.4 (2003) and DA 02-2138; ANSI C63.4 (2003) with FCC Method 47 CFR Part 15, Subpart B
Canada – Emissions	ICES-001; ICES-002; ICES-003; ICES-005; ICES-006
Vietnam – Emission & Immunity	TCN 68-193:2003; TCN 68-196:2001; TCVN 7189:2002; TCVN 7189:2009 (CISPR 22:2006)
Australia / New Zealand – Emissions and Immunity	AS/NZS 1044; AS/NZS 2279.3; AS/NZS 3548; AS/NZS 4251.1; AS/NZS 4251.2; AS/NZS CISPR 11; AS/NZS CISPR 14.1; AS/NZS CISPR 22; AS/NZS CISPR 24; AS/NZS 61000.3.2; AS/NZS 61000.3.3; AS/NZS 61000.6.3; AS/NZS 61000.6.4
Japan – Emissions	JEITA IT-3001; VCCI-V-3 (up to 6 GHz)
China – Emissions	GB9254; GB17625.1

<u>Test Technology:</u>	<u>Test Method(s):</u>
Taiwan – Emissions	CNS 13438 (<i>up to 6 GHz</i>); CNS 13783-1; CNS 13803; CNS 13439
Singapore – Emissions & Immunity	IDA TS EMC; CISPR 22; IEC 61000-4-2; IEC 61000-4-3; IEC 61000-4-4; IEC 61000-4-5; IEC 61000-4-6
FCC – Unlicensed Radio A1 to A4	<p>A1: 47 CFR Parts 11 (Emergency Alert System (EAS)), 15 (Radio Frequency Devices) and 18 (Industrial, Scientific, and Medical Equipment); FCC OST/MP-5(1986); ANSI C63.4(2003); ANSI C63.4(2009); ANSI C63.10(2009)</p> <p>A2: 47 CFR Part 15 (Radio Frequency Devices); ANSI C63.4(2003); ANSI C63.4(2009); ANSI C63.10(2009)</p> <p>A3: 47 CFR Part 15 (Radio Frequency Devices); ANSI C63.17:2006; ANSI C63.10(2009); IEEE Std 1528:2003 + A1; Std IEEE 528A:2005</p> <p>A4: 47 CFR Part 15 (Radio Frequency Devices); ANSI C63.10(2009); IEEE Std 1528:2003 + A1; Std IEEE 1528A:2005</p>
FCC – Licensed Radio B1 to B4	<p>B1: 47 CFR Parts 2 (Frequency Allocations and Radio Treaty Matters; General Rules and Regulations), 22 (Public Mobile Services), 24 (Personal Communications Services), 25 (Satellite Communications), and 27 (Miscellaneous Wireless Communications Services); ANSI/TIA-603-C (2004), ANSI/TIA-603-D(2010), Land Mobile FM or PM Communications Equipment Measurement and Performance Standard; IEEE Std 1528:2003 + Ad1; Std IEEE 1528A:2005</p> <p>B2: 47 CFR Parts 2 (Frequency Allocations and Radio Treaty Matters; General Rules and Regulations), 22 (Public Mobile Services), 74 (Experimental Radio Auxiliary, Special Broadcast and Other Program Distributional Services), 90 (Private Land Mobile Radio Services), 95 (Personal Radio Services), and 97 (Amateur Radio Services); ANSI/TIA-603-C (2004), ANSI/TIA-603-D(2010), Land Mobile FM or PM Communications Equipment Measurement and Performance Standard</p> <p>B3: 47 CFR Parts 2 (Frequency Allocations and Radio Treaty Matters; General Rules and Regulations); 80 (Stations in the Maritime Services), 87 (Aviation Services); ANSI/TIA-603-C (2004), ANSI/TIA-603-D(2010), Land Mobile FM or PM Communications Equipment Measurement and Performance Standard</p> <p>B4: 47 CFR Parts 2 (Frequency Allocations and Radio Treaty Matters; General Rules and Regulations); 27 (Broadband Radio Services (BRS) and Educational Broadband Services (EBS)), 74 (Experimental Radio Auxiliary, Special Broadcast and Other Program Distributional Services), and 101 (Fixed Microwave Services); ANSI/TIA-603-C (2004), ANSI/TIA-603-D(2010), Land Mobile FM or PM Communications Equipment Measurement and Performance Standard</p>

<u>Test Technology:</u>	<u>Test Method(s):</u>
Canada – Radio	RSS 102; RSS 111; RSS 112; RSS 117; RSS 118; RSS 119; RSS 123; RSS 125; RSS 127; RSS 129; RSS 131; RSS 132; RSS 133; RSS 134; RSS 135; RSS 136; RSS 137; RSS 138; RSS 139; RSS 141; RSS 142; RSS 170; RSS 181; RSS 182; RSS 191; RSS 192; RSS 194; RSS 195; RSS 196; RSS 197; RSS 199; RSS 210; RSS 220; RSS 213; RSS 215; RSS 243; RSS 287; RSS 288; RSS 310; RSS Gen
CE – Radio	EN 301 502; EN 301 511; EN 301 526; EN 301 681; EN 301 721; EN 301 751; EN 301 753; EN 301 783-2; EN 301 796; EN 301 797; EN 301 840-2; EN 301 843-1; EN 301 843-4; EN 301 843-5; EN 301 893; EN 301 908-01; EN 301 908-02; EN 301 908-03; EN 301 908-04; EN 301 908-05; EN 301 908-06; EN 301 908-07; EN 301 908-08; EN 301 908-09; EN 301 908-10; EN 301 908-11; EN 301 929-2; EN 301 997-2; EN 302 018-2; EN 302 054-2; EN 302 064-2; EN 302 066-2; EN 302 077-2; EN 302 186; EN 302 195-2; EN 302 217-3; EN 302 245-2; EN 302 288-2; EN 302 291-2; EN 302 296; EN 302 297; EN 302 326-2; EN 302 326-3; EN 302 340; EN 302 372-2; EN 302 426; EN 302 454-2; EN 302 480; EN 302 502; EN 302 510-2; EN 302 217-4-2; EN 300 224-1; EN 300 279; EN 300 339; EN 300 385; EN 301 839-2; EN 301 843-6; EN 302 017-2; EN 302 208-2; EN 302 217-2-2; ETS 300 329; ETS 300 445; ETS 300 446; ETS 300 683; ETS 300 826; ETS EN 300 328; ETSI EN 300 086-2; EN 302 217-1; EN 302 217-2-1; EN 302 217-4-1; EN 302 288-1; EN 302 908-12; EN 302 326-1; EN 301 929-1; EN 301 997-1; EN 300 224-2; EN 301 839-1; EN 301 843-1; EN 301 843-2; EN 301 843-3; EN 301 843-4; EN 301 843-5; EN 302 017-1; EN 302 208-1; EN 300 086-1; EN 300 113-1; EN 300 224-1; EN 300 341-1; EN 302 291-1; EN 302 500-1; EN 302 500-2; ETSI EN 300 113-2; ETSI EN 300 197; ETSI EN 300 198; ETSI EN 300 219-1; ETSI EN 300 219-2; ETSI EN 300 220-1; ETSI EN 300 220-2; ETSI EN 300 220-3; ETSI EN 300 224-2; ETSI EN 300 296-1; ETSI EN 300 296-2; ETSI EN 300 328-1; ETSI EN 300 328-2; ETSI EN 300 330; ETSI EN 300 330-1; ETSI EN 300 330-2; ETSI EN 300 341-2; ETSI EN 300 373-1; ETSI EN 300 373-2; ETSI EN 300 373-3; ETSI EN 300 390-1; ETSI EN 300 390-2; ETSI EN 300 422-1; ETSI EN 300 422-2; ETSI EN 300 431; ETSI EN 300 440-1; ETSI EN 300 440-2; ETSI EN 300 454-1; ETSI EN 300 454-2; ETSI EN 300 718-2; ETSI EN 301 021; ETSI EN 301 166-1; ETSI EN 301 166-2; ETSI EN 301 178-2; ETSI EN 301 213-1; ETSI EN 301 213-2; ETSI EN 301 213-3; ETSI EN 301 213-4; ETSI EN 301 213-5; ETSI EN 301 357-1; ETSI EN 301 357-2; ETSI EN 301 390; ETSI EN 301 459; ETSI EN 301 489-01 (excluding section 9.6); ETSI EN 301 489-02; ETSI EN 301 489-03; ETSI EN 301 489-04; ETSI EN 301 489-05; ETSI EN 301 489-06; ETSI EN 301 489-07; ETSI EN 301 489-08; ETSI EN 301 489-09; ETSI EN 301 489-10; ETSI EN 301 489-11; ETSI EN 301 489-12; ETSI EN 301 489-13; ETSI EN 301 489-14; ETSI EN 301 489-15; ETSI EN 301 489-16; ETSI EN 301 489-17; ETSI EN 301 489-18; ETSI EN 301 489-19; ETSI EN 301 489-20; ETSI EN 301 489-22; ETSI EN 301 489-23; ETSI EN 301 489-24; ETSI EN 301 489-25; ETSI EN 301 489-26;

<u>Test Technology:</u>	<u>Test Method(s):</u>
CE – Radio (continued)	ETSI EN 301 489-27; ETSI EN 301 489-28; ETSI EN 301 489-31; ETSI EN 301 489-32; IEC 60945; EN 302 480
IDA – Radio	IDA TS AR; IDA TS CT-CTS; IDA TS GMPCS; IDA TS LMR; IDA TS RPG; IDA TS SRD; IDA TS UWB; IDA TS WBA; IDA TS CMT; IDA TS CBS
Vietnam – Radio	QCVN 54:2011/BTTTT; TCN 68-242:2006; QCVN 11:2010/BTTTT; QCVN 17:2010/BTTTT
Korea – Radio	KCC Public Notification 2012-12; RRA Announce 2011-32; RRA Public Notification 2010-46
Taiwan – Radio	LP0002; PLMN07; PLMN01; PLMN08
Australia - New Zealand – Radio	AS 2772.2; AS/NZS 4281; AS/NZS 4268; AS/NZS 4280.1; AS/NZS 4583; AS/NZS 4280.2; AS/NZS 4281; AS/NZS 4295; AS/NZS 4582; AS/NZS 4769.1; AS/NZS 4769.2; AS/NZS 4770; AS/NZS 4771
Hong Kong – Radio	HKCA 1002; HKCA 1007; HKCA 1008; HKCA 1010; HKCA 1015; HKCA 1016; HKCA 1020; HKCA 1022; HKCA 1026; HKCA 1027; HKCA 1029; HKCA 1030; HKCA 1031; HKCA 1032; HKCA 1033; HKCA 1034; HKCA 1035; HKCA 1036; HKCA 1037; HKCA 1039; HKCA 1041; HKCA 1042; HKCA 1043; HKCA 1044; HKCA 1046; HKCA 1047; HKCA 1048; HKCA 1049; HKCA 1051; HKCA1052; HKCA1053; HKCA 1054; HKCA 1055; HKCA 1056; HKCA 1057; HKCA 1061
FCC Telephone Terminal Equipment Scope C1	TIA-968-B; FCC Rule Part 68; 47 CFR Part 68.316; 47 CFR Part 68.317; ANSI/TIA/EIA-464-C; TIA-810-B; T1.TRQ6 (2002); TCB-31-B (1998); TIA-470.110-C; TIA-920
Canada – Telecom	CS-03 Part I Issue 9:2010, Amendment 4; CS-03 Part II Issue 9:2004; CS-03 Part V Issue 9:2009 Amendment 1; CS-03 Part VI Issue 9:2004; CS-03 Part VII Issue 9:2006 Amendment 3; CS-03 Part VIII Issue 9:2009 Amendment 4
Europe – Telecom	TBR 2: 01-1997; TBR 004 Ed.1.95 + A1 (97); TBR 1; TBR 3; TBR 12:A1 01-1996; TBR 013 ed.1; TBR 024 ed.1; TBR 25; TBR 38 ed.1; TBR 021; ETSI ES 203 021-05 ; ETSI ES 203 021-2 ; ETSI ES 021-3; ETSI EG 201 121; ETSI EN 301 437; ETSI TS 101 270-1; ITU-T Recommendation Q.920; ITU-T Recommendation Q.920 – Amendment 1; ITU-T Recommendation Q.921; ITU-T Recommendation Q.921 – Amendment 1; ITU-T Recommendation Q.931; ITU-T Recommendation Q.931 – Amendment 1; Erratum 1 (02/2003) ITU-T Recommendation Q.931 (05/1998);

<u>Test Technology:</u>	<u>Test Method(s):</u>
Europe – Telecom (cont'd)	ISDN User Network Interface Layer 3 Specification for Basic Call Control; ITU-T Recommendation P.300
Australia – Telecom Australia – Telecom	AS/CA S003.1:2010; AS/CA S002:2011; AS/ACIF S004:2008; AS/CA S042.1:2011; AS/CA S003.2:2010; AS/CA S003.3:2010; AS/CA S004:2010; AS/ACIF S006:2008; AS/ACIF S041.1:2009 AS/ACIF S041.2:2009; AS/ACIF S041.3:2009; AS/ACIF S042.1:2008; AS/ACIF S043.2:2008; AS/ACIF S043.3:2008; AS/ACIF S002:05; AS/ACIF S003:06; AS/ACIF S004:08; AS/ACIF S006:01; AS/ACIF S016:01; AS/ACIF S031:01; AS/ACIF S038:01; AS/ACIF S040:01; AS/ACIF S041:05; AS/ACIF S043.2:06
New Zealand – Telecom	PTC200:2006; PTC200 Issue No.2:97 + A1(980); PTC220; PTC273:2007; TNA 115; TNA 117
Singapore – Telecom	IDA TS ADSL; IDA TS DLCN; IDA TS ISDN BA; IDA TS ISDN PRA; IDA TS BISDN; IDA TS-PSTN; IDA TS ACLIP; IDA TS CM
Hong Kong – Telecom	HKCA 2011; HKCA 2012; HKCA 2013; HKCA 2014; HKCA 2015; HKCA 2017; HKCA 2018; HKCA 2019; HKCA 2022; HKCA 2023; HKCA 2024; HKCA 2026; HKCA 2027; HKCA 2028; HKCA 2029; HKCA 2030; HKCA 2031; HKCA 2032; HKCA 2033
Vietnam – Telecom	QCVN 10:2010/BTTTT; QCVN 19:2010/BTTTT; TCN 68-189:2000; QCVN 18:2010/BTTTT; TCVN 7317:2003 (CISPR 24:1997); QCVN 12:2010/BTTTT; QCVN 13:2010/BTTTT; QCVN 55:2011/BTTTT; QCVN 15:2010/BTTTT
Korea – Telecom	Presidential Decree 21098; RRA Public Notification 2010-36; RRA Public Notification 2009-38; RRA Announce 2011-2; Annex 1 (RRA Announce 2011-2); Annex 3 (RRA Announce 2011-2); Annex 5 (RRA Announce 2011-2); Annex 6 (RRA Announce 2011-2)

<u>Test Technology:</u>	<u>Test Method(s):</u>
China – Telecom	YD/T 514-1:98; YD/T 1277.1-2003; GB/T 17904.1-1999; GB/T 17904.2-1999; GB/T 17154.1-1997; GB/T 17154.2-1997; YD/T1091-2000; YD/T1006-1999; GB/T 17789-1999
Taiwan – Telecom	PSTN01:2007; ADSL01:08; ID0002:2007; IS6100: 93
Japan – Telecom	JATE Blue Book, Green Book; Ministerial Ordinance of the Ministry of Posts and Telecommunications No. 31 of April 1, 1985 (last amended on March 22 2004); Ordinance Concerning Technical Conditions Compliance Approval etc. of Terminal Equipment (amended by the Ministerial Ordinance of the MIC No.92 of October 25, 2010) and Ordinance Concerning Terminal Facilities etc. (amended by the Ministerial Ordinance of the MIC No. 91 of October 25, 2010)
South Africa – Telecom	DPT-TE-001; TE-002; TE-003; TE-004; TE-005; TE-006; TE-007; TE-008; TE-009; TE-010; TE-012 (telephone interface); TE-013 (telephone interface); TE-014; TE-015; TE-018; SWS-001; SWS-002; SWS-003; SWS-004; SWS-005; SWS-006; SWS-007; SWS-008; SWS-009; SWS-010
Israel – Telecom	Israel MoC Spe. 23/96
Mexico – Telecom	NOM-151-SCT1-1999; NOM-152-SCT1-1999
Argentina – Telecom	CNC-ST2-44-01
Brazil – Telecom	Resolution 392-2005
International Telecom Union	ITU-T-G.703:01; ITU-T-G.823:93; ITU-T G.824; ITU-T G.825; ITU-T-G.991.2; ITU-T-G.992.1; ITU-T-G.992.3; ITU-T-G.992.5; ITU-T-G.993.1
Product Safety	IEC 60950-1; EN 60950-1; UL 60950-1; IEC 60601-1-1; CAN/CSA 22.2 NO. 60950-1-03; SS-EN 60950-1; AS/NZ 60950-1, (voltage surge testing up to 6kV, excluding Annex A, H, and Y); CNS 14336, CNS 14408; GB4943; President Notice 20664; RRA Public Notification 2011-14; RRA Announce 2011-3; Annex 1(RRA Announce 2011-3); QCVN 22:2010/BTTTT; SABS IEC 60950; IEC/EN 61558; IEC/EN 61558-2-7; EN 62115; IEC 60215; EN 60958; EN 60598; IEC 215 (1987) + A1 (1992) + A2 (1994)
Japan - Radio	ARIB STD-T81; ARIB STD-T66; RCR STD-1; RCR STD-29; ARIB STD-T94 Fascicle 1; ARIB STD-T90; ARIB STD-T89; RCR STD-33
SAR & HAC	IEEE P1528:2003 + Ad1; IEEE 1528A:2005; FCC OET Bulletin 65 Supplement C; FCC OET Bulletin 65; ANSI C95; ANSI C63.19; FCC 47 CFR 20.19; H46-2/99-273E; EN 50360; EN 50361; IEC62209-1; IEC 62209-2; EN 50371; EN 50383; EN 50357; EN 50364;

<u>Test Technology:</u>	<u>Test Method(s):</u>
SAR & HAC (<i>cont'd</i>)	KCC Public Notification 2009-27; RRA Public Notification 2010-45; KCC Public Notification 2012-2; CNS 14958-1; CNS 14959; NZS 2772.1; Resolution N 533; AS/NZS 2772.2:2011
Japan – Notification No. 88 of MIC 2004	
Table No 13	CB Radio
Table No 21	Cordless Telephone
Table Nos 22-1 thru 22-17	Low Power Radio Equipment
Table No 36	Low Power Security System
Table No 43	Low Power Data Communication in the 2.4 GHz Band
Table No 44	Low Power Data Communication in the 2.4 GHz Band
Table No 45	Low Power Data Communication in the 5.2, 5.3, 5.6 GHz Bands
Table No 46	Low Power Data Communication in the 25 and 27 GHz Bands
Table No 47	Base Station for 5 GHz Band Wireless Access System
Table No 47	Base Station for 5 GHz Band Wireless Access System (low spurious type)
Table No 47	Land Mobile Relay for 5 GHz Band Wireless Access System (limited for use in special zones)
Table No 47	Land Mobile Relay for 5 GHz Band Wireless Access System (limited for use in special zones, low spurious type)
Table No 47	Land Mobile Relay for 5 GHz Band Wireless Access System
Table No 47	Land Mobile Relay for 5 GHz Band Wireless Access System (low spurious type)
Table No 47	Land Mobile Relay for 5 GHz Band Wireless Access System (low power type)
Table No 50	Digital Cordless Telephone
Table No 50	PHS Base Station
Table No 50	PHS Land Mobile Station
Table No 50	PHS Relay Station
Table No 50	PHS Test Station
Table No 64	Mobile Station for Dedicated Short Range Communication Systems
Table No 64	Base Station for Dedicated Short Range Communication Systems
Table No 64	Test Station for Dedicated Short Range Communication Systems
Table No 70	UWB (Ultra Wide Band) Radio System

*Limitations for listed standards are indicated by italics and Scope excludes protocol sections of applicable standards.

A

SIEMIC, INC.

Accessing global markets

Title: RF Test Report of RF Switched Outlet
Model: ARPS15RF2W4 / ARPS15RF2M4
To: FCC 15.247:2011, RSS-210 Issue 8:2010

Serial# RF_SL12062002-LHS-007_FCC-IC
Issue Date Nov 27th, 2012
Page 56 of 74
www.sieminc.com



American Association for Laboratory Accreditation

Accredited Product Certification Body

A2LA has accredited

SIEMIC, INC.

Milpitas, CA

for technical competence as a

Product Certification Body

This product certification body is accredited in accordance with the recognized International Standard ISO/IEC Guide 65:1996 *General requirements for bodies operating product certification systems*. This accreditation demonstrates technical competence for a defined scope and the operation of a quality management system.

Presented this 19th day of September 2012.

President & CEO
For the Accreditation Council
Certificate Number 2742.02
Valid to September 30, 2014



For the product certification schemes to which this accreditation applies, please refer to the organization's Product Certification Scope of Accreditation

SCOPE OF ACCREDITATION TO ISO/IEC GUIDE 65:1996

SIEMIC, INC.
 775 Montague Expressway
 Milpitas, CA 95035
 Mr. Snell Leong (Authorized Representative) Phone: 408 526 1188
www.siemic.com

PRODUCT CERTIFICATION CONFORMITY ASSESSMENT BODY (CAB)

Valid to: September 30, 2014

Certificate Number: 2742.02

In recognition of the successful completion of the A2LA Certification Body Accreditation Program evaluation, including the US Federal Communications Commission (FCC), Industry Canada (IC), Singapore (IDA), Hong Kong (OFCA) and Japan (MIC) requirements for the indicated types of product certifications, accreditation is granted to this organization to certify products in accordance with the following product certification schemes:

Economy:
Scope:
Federal Communication Commission - (FCC)

Unlicensed Radio Frequency Devices	A1, A2, A3, A4
Licensed Radio Frequency Devices	B1, B2, B3, B4
Telephone Terminal Equipment	C

**Please refer to FCC TCB Program Roles and Responsibilities, released January 6, 2011, detailing scopes, roles and responsibilities. [TCB Program Roles and Responsibilities](#)*

Industry Canada - (IC)

Radio	Scope 1-Licence-Exempt Radio Frequency Devices; Scope 2-Licensed Personal Mobile Radio Services; Scope 3-Licensed General Mobile & Fixed Radio Services; Scope 4-Licensed Maritime & Aviation Radio Services; Scope 5-Licensed Fixed Microwave Radio Services;
-------	--

**Please refer to Industry Canada (IC) website at: <http://www.ic.gc.ca/etc/site/smt-gst.nsf/eng/sf09888.html>*

IDA – Singapore

Line Terminal Equipment	All Technical Specifications for Line Terminal Equipment – Table 1 of IDA MRA Recognition Scheme: 2011, Annex 2
Radio-Communication Equipment	All Technical Specifications for Radio-Communication Equipment – Table 2 of IDA MRA Recognition Scheme: 2011, Annex 2

**Please refer to Info-Communication Development Authority (IDA) Singapore website at:
http://www.ida.gov.sg/doc/Policyes%20and%20Regulation/Policyes_and_Regulation_Level2/20060609145118/MRARecScheme.pdf*

OFCA – Hong Kong

Radio Equipment	HKCA 1001, 1002, 1003, 1004, 1005, 1006, 1007, 1008, 1010, 1015, 1016, 1019, 1020, 1022, 1026, 1027, 1033, 1034, 1035, 1036, 1037, 1038, 1039, 1041, 1042, 1043, 1044, 1045, 1046, 1047, 1048, 1049, 1050, 1052, 1053, 1054, 1056, 1057, 1061
-----------------	---

**Please refer to the Office of the Communications Authority's website at:
[Radio Equipment Specifications \(HKCA 10XX\)](#)*

Fixed Network Equipment	HKCA 2001, 2005, 2011, 2012, 2013, 2014, 2015, 2016, 2017, 2018, 2019, 2020, 2021, 2022, 2023, 2024, 2026, 2027, 2028, 2029, 2030, 2031, 2032, 2033, 2034, 2035, 2036, 2037, 2040, 2041, 2102, 2103, 2104, 2108, 2201, 2202, 2203, 2204
-------------------------	---

**Please refer to the Office of the Communications Authority's website at:
[Fixed Network Equipment Specifications \(HKCA 2XXX\)](#)*

MIC – Japan

Telecommunications Business Law (Terminal Equipment)	Scope A1 - Terminal Equipment for the Purpose of Calls
Radio Law (Radio Equipment)	Scope B1 - Specified Radio Equipment specified in, Article 38-2-2, paragraph 1, item 1 of the Radio Law



A

SIEMIC, Inc.

Accessing global markets

Title: RF Test Report of RF Switched Outlet
Model: ARPS15RF2W4 / ARPS15RF2M4
To: FCC 15.247:2011, RSS-210 Issue 8:2010

Serial# RF_SL12062002-LHS-007_FCC-IC
Issue Date Nov 27th, 2012
Page 59 of 74
www.sieminc.com

SIEMIC ACCREDITATION DETAILS: FCC Test Site Registration No. 881796

FEDERAL COMMUNICATIONS COMMISSION

**Laboratory Division
7435 Oakland Mills Road
Columbia, MD 21046**

August 03, 2012

Registration Number: 881796

SIEMIC Labs
775 Montague Expressway,
,
Milpitas, CA 95035

Attention: Leslie BAI

Re: Measurement facility located at 775 Montague Expressway, Milpitas, CA 95035
Anechoic chamber (10 meters)
Date of Listing: August 03, 2012

Dear Sir or Madam:

Your request for registration of the subject measurement facility has been reviewed and found to be in compliance with the requirements of Section 2.948 of the FCC rules. The information has, therefore, been placed on file and the name of your organization added to the list of facilities whose measurement data will be accepted in conjunction with applications for Certification under Parts 15 or 18 of the Commission's Rules. Please note that the file must be updated for any changes made to the facility and the registration must be renewed at least every three years.

Measurement facilities that have indicated that they are available to the public to perform measurement services on a fee basis may be found on the FCC website www.fcc.gov under E-Filing, OET Equipment Authorization Electronic Filing, Test Firms.

Sincerely,

Katie Hawkins
Electronics Engineer

Title: RF Test Report of RF Switched Outlet
Model: ARPS15RF2W4 / ARPS15RF2M4
To: FCC 15.247:2011, RSS-210 Issue 8:2010

Serial# RF_SL12062002-LHS-007_FCC-IC
Issue Date Nov 27th, 2012
Page 60 of 74
www.siemic.com

SIEMIC ACCREDITATION DETAILS: Industry of Canada CAB ID : US0160

UNITED STATES DEPARTMENT OF COMMERCE
National Institute of Standards and Technology
Gaithersburg, Maryland 20899

March 4, 2009

Mr. Leslie Bai
SIEMIC, Inc.
2206 Ringwood Avenue
San Jose, CA 95131

Dear Mr. Bai:

NIST is pleased to inform you that your laboratory has been recognized by Industry Canada (IC), under the Asia Pacific Economic Cooperation for Telecommunications Equipment Mutual Recognition Arrangement (APEC Tel MRA). Your laboratory is now designated to act as a Conformity Assessment Body (CAB) under Appendix B, **Phase I** Procedures, of the APEC Tel MRA. The pertinent information about your laboratory's designation is as follows:

CAB Name: SIEMIC, Inc.
Physical Location: 2206 Ringwood Avenue, San Jose, CA 95131 USA
Identification No.: US0160
Recognized Scope: CS-03 Part I, II, V, VI, VII and VIII

You may submit test data to IC to verify that the equipment to be imported into Canada satisfies the applicable requirements. The designation of your organization will remain in force as long as its accreditation for the designated scope remains valid and comply with the designation requirements.

Recognized CABs are listed on the NIST website at <http://ts.nist.gov/mra>. Please contact Ms. Ramona Saar at (301) 975-5521 or ramona.saar@nist.gov if you have any questions.

Sincerely,

A handwritten signature in black ink, appearing to read "David F. Alderman".

David F. Alderman
Group Leader, Standards Coordination and Conformity Group
Standards Services Division

Enclosure

cc: CAB Program Manager

A

 SIEMIC, INC. Accessing global markets	Title: RF Test Report of RF Switched Outlet Model: ARPS15RF2W4 / ARPS15RF2M4 To: FCC 15.247:2011, RSS-210 Issue 8:2010	Serial# RF_SL12062002-LHS-007_FCC-IC Issue Date Nov 27th, 2012 Page 61 of 74 www.siemic.com
--	--	--

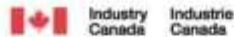
SIEMIC ACCREDITATION DETAILS: Industry of Canada Test Site Registration No. 4842-1

July 03, 2012

OUR FILE: 46405-4842
Submission No: 157820Siemic Inc.
775 Montague Expressway
Milpitas, CA, 95035
United States**Attention:**

Dear Sir/Madame: Snell Leong

The Bureau has received your application for the renewal of 3/10m alternative test site. Be advised that the information received was satisfactory to Industry Canada. The following number(s) is now associated to the site(s) for which registration / renewal was sought (**Site# 4842D-2**). Please reference the appropriate site number in the body of test reports containing measurements performed on the site. In addition, please keep for your records the following information;

- The company address code associated to the site(s) located at the above address is: **4842D**

Furthermore, to obtain or renew a unique site number, the applicant shall demonstrate that the site has been accredited to ANSI C63.4-2003 or later. A scope of accreditation indicating the accreditation by a recognized accreditation body to ANSI C63.4-2003 or later shall be accepted. Please indicate in a letter the previous assigned site number if applicable and the type of site (example: 3 metre OATS or 3 metre chamber). If the test facility is not accredited to ANSI C63.4-2003 or later, the test facility shall submit test data demonstrating full compliance with the ANSI standard. The Bureau will evaluate the filing to determine if recognition shall be granted.

The frequency for re-validation of the test site and the information that is required to be filed or retained by the testing party shall comply with the requirements established by the accrediting organization. However, in all cases, test site re-validation shall occur on an interval not to **exceed three years**. There is no fee or form associated with an OATS filing. OATS submissions are encouraged to be submitted electronically to the Bureau using the following URL:
http://strategis.ic.gc.ca/epic/internet/inceb-bhst.nsf/en/h_tt00052e.html.

If you have any questions, you may contact the Bureau by e-mail at certification.bureau@ic.gc.ca Please reference our file and submission number above for all correspondence.

Yours sincerely,

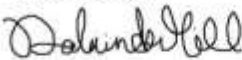
Dalwinder Gill
For: Wireless Laboratory Manager
Certification and Engineering Bureau
3701 Carling Ave., Building 94
P.O. Box 11490, Station "H"
Ottawa, Ontario K2H 8S2
Email: dalwinder.gill@ic.gc.ca
Tel. No. (613) 998-8363
Fax. No. (613) 990-4752

A

SIEMIC, INC.

Accessing global markets

Title: RF Test Report of RF Switched Outlet
Model: ARPS15RF2W4 / ARPS15RF2M4
To: FCC 15.247:2011, RSS-210 Issue 8:2010

Serial# RF_SL12062002-LHS-007_FCC-IC
Issue Date Nov 27th, 2012
Page 62 of 74
www.siemic.com

SIEMIC ACCREDITATION DETAILS: FCC DOC CAB Recognition : US1109

FEDERAL COMMUNICATIONS COMMISSION

**Laboratory Division
7435 Oakland Mills Road
Columbia, MD 21046**

August 28, 2008

Siemic Laboratories
2206 Ringwood Ave.,
San Jose, CA 95131

Attention: Leslie Bai

Re: Accreditation of Siemic Laboratories
Designation Number: US1109
Test Firm Registration #: 540430

Dear Sir or Madam:

We have been notified by American Association for Laboratory Accreditation that Siemic Laboratories has been accredited as a Conformity Assessment Body (CAB).

At this time Siemic Laboratories is hereby designated to perform compliance testing on equipment subject to Declaration Of Conformity (DOC) and Certification under Parts 15 and 18 of the Commission's Rules.

This designation will expire upon expiration of the accreditation or notification of withdrawal of designation.

Sincerely,

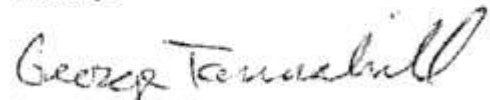

George Tannahill
Electronics Engineer

Title: RF Test Report of RF Switched Outlet
 Model: ARPS15RF2W4 / ARPS15RF2M4
 To: FCC 15.247:2011, RSS-210 Issue 8:2010

Serial# RF_SL12062002-LHS-007_FCC-IC
 Issue Date Nov 27th, 2012
 Page 63 of 74
 www.sieminc.com

SIEMIC ACCREDITATION DETAILS: Australia CAB ID : US0160

UNITED STATES DEPARTMENT OF COMMERCE
National Institute of Standards and Technology
 Gaithersburg, Maryland 20899

November 20, 2008

Mr. Leslie Bai
 SIEMIC, Inc.
 2206 Ringwood Avenue
 San Jose, CA 95131

Dear Mr. Bai:

NIST is pleased to inform you that your laboratory has been recognized by the Australian Communications and Media Authority (ACMA) under the Asia Pacific Economic Cooperation for Telecommunications Equipment Mutual Recognition Arrangement (APEC Tel MRA). Your laboratory is now designated to act as a Conformity Assessment Body (CAB) under Appendix B, **Phase I** Procedures, of the APEC Tel MRA. The pertinent information about your laboratory's designation is as follows:

CAB Name: Siemic, Inc.
 Physical Location: 2206 Ringwood Avenue, San Jose, CA 95131
 Identification No.: US0160
 Recognized Scope: EMC: AS/NZS 4251.1 (until 5/31/2009), AS/NZS 4251.2 (until 5/31/2009), AS/NZS CISPR 11, AS/NZS CISPR 14.1, AS/NZS CISPR 22, AS/NZS 61000.6.3, AS/NZS 61000.6.4
Radiocommunications: AS/NZS 4281, AS/NZS 4268, AS/NZS 4280.1, AS/NZS 4280.2, AS/NZS 4295, AS/NZS 4582, AS/NZS 4583, AS/NZS 4769.1, AS/NZS 4769.2, AS/NZS 4770, AS/NZS 4771
Telecommunications: AS/ACIF S002:05, AS/ACIF S003:06, AS/ACIF S004:06, AS/ACIF S006:01, AS/ACIF S016:01, AS/ACIF S031:01, AS/ACIF S038:01, AS/ACIF S040:01, AS/ACIF S041:05, AS/ACIF S043.2:06, AS/NZS 60950.1

You may submit test data to ACMA to verify that the equipment to be imported into Australia satisfies the applicable requirements. The designation of your organization will remain in force as long as its accreditation for the designated scope remains valid and comply with the designation requirements. Recognized CABs are listed on the NIST website at <http://ts.nist.gov/mra>. Please contact Ms. Ramona Saar, at (301) 975-5521 or ramona.saar@nist.gov if you have questions.

Sincerely,

David F. Alderman
 Group Leader, Standards Coordination and Conformity Group
 Standards Services Division

Enclosure

cc: Snell Leong, Siemic, Inc.; Ramona Saar, NIST

SIEMIC ACCREDITATION DETAILS: Korea CAB ID: US0160

UNITED STATES DEPARTMENT OF COMMERCE
National Institute of Standards and Technology
 Gaithersburg, Maryland 20899

December 3, 2012

Mr. Leslie Bai
 SIEMIC, Inc.
 775 Montague Expressway
 Milpitas, CA 95035

Dear Mr. Bai:

NIST is pleased to inform you that your laboratory continues to be recognized by the National Radio Research Agency (RRA) Korea Communications Commission (KCC) under Phase I of the APEC Tel MRA. The scope of recognition has been updated. The information regarding your recognition is as follows:

CAB Name: SIEMIC, Inc.
Physical Location: 775 Montague Expressway, Milpitas, CA 95035
Identification No.: US0160
Updated Scope: **EMI:** RRA Public Notification 2011-24, RRA Announce 2011-30, KN11, KN13, KN14-1, KN 22, KN 41, KN 50, KN 15, KN 19, KN 60, KN 16-1-1, KN 16-1-2, KN 16-1-3, KN 16-1-4, KN 16-1-5, KN 16-2-1, KN 16-2-2, KN 16-2-3, KN 16-2-4, KN 301-489-01, KN 301-489-07, KN 301-489-17, KN 301-489-24, KN 301-489-06, KN 301-489-13, KN 301-489-05, KN 301-489-03, KN 301-489-09, KN 301-489-26, KN 301-489-18, KN 301-489-15, KN 301-489-02, KN 301-489-27, KN 301-489-32, KN 301-489-20, KN 60945;

EMS: RRA Public Notification 2011-25, RRA Announce 2011-31, KN 61000-4-2, KN 61000-4-3, KN 61000-4-4, KN 61000-4-5, KN 61000-4-6, KN 61000-4-8, KN 61000-4-11, KN 60601-1-2, KN 20, KN 14-2, KN 24, KN 41, KN 51, KN 301-489-01, KN 301-489-07, KN 301-489-17, KN 301-489-24, KN 301-489-06, KN 301-489-13, KN 301-489-05, KN 301-489-03, KN 301-489-09, KN 301-489-26, KN 301-489-18, KN 301-489-15, KN 301-489-02, KN 301-489-27, KN 301-489-32, KN 301-489-20, KN 60945;

RF: KCC Public Notification 2012-12, RRA Announce 2011-32, RRA Public Notification 2010-46;

SAR: KCC Public Notification 2009-27, RRA Public Notification 2010-45, KCC Public Notification 2012-2;

TELECOM: RRA Public Notification 2010-36; RRA Public Notification 2009-38, RRA Announce 2011-2 (Annexes 1, 3, 5, 6)

NIST

Title: RF Test Report of RF Switched Outlet
Model: ARPS15RF2W4 / ARPS15RF2M4
To: FCC 15.247:2011, RSS-210 Issue 8:2010

Serial# RF_SL12062002-LHS-007_FCC-IC
Issue Date Nov 27th, 2012
Page 65 of 74
www.sieminc.com

You may submit test data to RRA/KCC to verify that the equipment to be imported into Korea satisfies the applicable requirements. The recognition of your organization will remain in force as long as the accreditation for the designated scope remains valid and your organization complies with the designation requirements.

Recognized CABs are listed on the NIST website at <http://gsi.nist.gov/global/index.cfm/L1-4/L2-16/L3-90>. If you have any questions please contact Ramona Saar via email at ramona.saar@nist.gov or phone at (301) 975-5521.

Sincerely,



David F. Alderman
Standards Services Group

Enclosure

cc: Ramona Saar

A

SIEMIC, INC.

Accessing global markets

Title: RF Test Report of RF Switched Outlet
 Model: ARPS15RF2W4 / ARPS15RF2M4
 To: FCC 15.247:2011, RSS-210 Issue 8:2010

Serial# RF_SL12062002-LHS-007_FCC-IC
 Issue Date Nov 27th, 2012
 Page 66 of 74
 www.sieminc.com

RRA 국립전파연구원**National Radio Research Agency**

29, Wonhyoro 41Gil, Yongsan-gu, Seoul, 140-848, Korea
 Tel: +82 2 710 6600, Fax: +82 2 710 6629
 Homepage : www.rra.go.kr

November 27, 2012

Mr. David F. Alderman
 Group Leader, Standards Coordination and Conformity Group
 National Institute of Standards and Technology
 100 Bureau Drive, Stop 2100
 Gaithersburg, Maryland 20899-2100, USA

Dear Mr. David F. Alderman:

This is to confirm the recognition by National Radio Research Agency of

SIEMIC, Inc. (US0160)

as an accredited Conformity Assessment Body (CAB) under the terms of Phase I of the APEC TEL MRA.
 The scope for which this laboratory has been recognized is given below.

Coverage	Standards	Date of Recognition
Current Scope	EMI : RRA Public Notification 2011-18, RRA Announce 2010-5, KN 11, KN 13, KN14-1, KN 22, KN 41, KN 50, KN 15, KN 19, KN 60, KN 16-1-1, -1-2, -1-3, -1-4, -1-5, -2-1, -2-2, -2-3, -2-4 EMS : RRA Public Notification 2011-17, RRA Announce 2010-6, KN 61000-4-2, -4-3, -4-4, -4-5, -4-6, -4-8, -4-11, KN 60101-1-2, KN 20, KN 24, KN 41, KN 51 RF : KCC Public Notification 2011-31, KCC Public Notification 2011-10, RRA Public Notification 2010-46, KN 301-489-01, -489-07, -489-17, -489-24 SAR : KCC Public Notification 2009-27, RRA Public Notification 2010-45, KCC Public Notification 2011-10 TELECOM : RRA Public Notification 2010-36, RRA Public Notification 2009-38	November 27, 2012
Updated Scope	EMI : RRA Public Notification 2011-24, RRA Announce 2011-30, KN 11, KN 13, KN 14-1, KN 22, KN 41, KN 50, KN 15, KN 19, KN 60, KN 16-1-1, -1-2, -1-3, -1-4, -1-5, -2-1, -2-2, -2-3, -2-4, KN 301-489-01, -489-07, -489-17, -489-24, -489-06, -489-13, -489-05, -489-03, -489-09, -489-26, -489-18, -489-15, -489-02, -489-27, -489-32, -489-20, KN 60945 EMS : RRA Public Notification 2011-25, RRA Announce 2011-31, KN 61000-4-2, -4-3, -4-4, -4-5, -4-6, -4-8, -4-11, KN 60601-1-2, KN 20, KN 14-2, KN 24, KN 41, KN 51, KN 301-489-01, -489-07, -489-17, -489-24, -489-06, -489-13, -489-05, -489-03, -489-09, -489-26, -489-18, -489-15, -489-02, -489-27, -489-32, -489-20, KN 60945 RF : KCC Public Notification 2012-12, RRA Announce 2011-32, RRA Public Notification 2010-46 SAR : KCC Public Notification 2009-27, RRA Public Notification 2010-45, KCC Public Notification 2012-2 TELECOM : RRA Public Notification 2010-36, RRA Public Notification 2009-38, RRA Announce 2011-2(Annexes 1, 3, 5, 6)	

This recognition is contingent upon the maintenance of this CAB's accreditation status and is limited to the standards listed above.

If you have any inquiries about this recognition, please contact to Conformity Policy Division of National Radio Research Agency with above address and telephone numbers.

Best Regards,

Yoon, Hye-Joo
 Director



Conformity Policy Division

cc: Ramona Saar – NIST
 Gerry Funk – NIST

A

SIEMIC, Inc.

Accessing global markets

Title: RF Test Report of RF Switched Outlet
Model: ARPS15RF2W4 / ARPS15RF2M4
To: FCC 15.247:2011, RSS-210 Issue 8:2010

Serial# RF_SL12062002-LHS-007_FCC-IC
Issue Date Nov 27th, 2012
Page 67 of 74
www.siemic.com

SIEMIC ACCREDITATION DETAILS: Taiwan BSMI Accreditation No. SL2-IN-E-1130R

UNITED STATES DEPARTMENT OF COMMERCE
National Institute of Standards and Technology
Gaithersburg, Maryland 20899

May 3, 2006

Mr. Leslie Bai
SIEMIC Laboratories
2206 Ringwood Avenue
San Jose, CA 95131

Dear Mr. Bai:

I am pleased to inform you that your laboratory has been recognized by the Chinese Taipei's Bureau of Standards, Metrology, and Inspection (BSMI) under the Asia Pacific Economic Cooperation (APEC) Mutual Recognition Arrangement (MRA). Your laboratory is now designated to act as a Conformity Assessment Body (CAB) under Appendix B, **Phase I** Procedures, of the APEC Tel MRA. You may submit test data to BSMI to verify that the equipment to be imported into Chinese Taipei satisfies the applicable requirements. The designation of your organization will remain in force as long as its accreditation for the designated scope remains valid and comply with the designation requirements. The pertinent designation information is as follows:

- BSMI number: **SL2-IN-E-1130R** (Must be applied to the test reports)
- U.S Identification No: **US0160**
- Scope of Designation: **CNS 13438**
- Authorized signatory: **Mr. Leslie Bai**

The names of all recognized CABs will be posted on the NIST website at <http://ts.nist.gov/mra>. If you have any questions, please contact Mr. Dhillon at 301-975-5521. We appreciate your continued interest in our international conformity assessment activities.

Sincerely,

David F. Alderman
Group Leader, Standards Coordination and Conformity Group

cc: Jogindar Dhillon

NIST

Title: RF Test Report of RF Switched Outlet
Model: ARPS15RF2W4 / ARPS15RF2M4
To: FCC 15.247:2011, RSS-210 Issue 8:2010

Serial# RF_SL12062002-LHS-007_FCC-IC
Issue Date Nov 27th, 2012
Page 68 of 74
www.siemic.com

SIEMIC ACCREDITATION DETAILS: Taiwan NCC CAB ID: US0160

UNITED STATES DEPARTMENT OF COMMERCE
National Institute of Standards and Technology
Gaithersburg, Maryland 20899

April 25, 2011

Mr. Leslie Bai
SIEMIC, Inc.
2206 Ringwood Avenue
San Jose, CA 95131

Dear Mr. Bai:

NIST is pleased to inform you that your laboratory has been recognized by the National Communications Commission (NCC) under the Asia Pacific Economic Cooperation for Telecommunications Equipment Mutual Recognition Arrangement (APEC Tel MRA). Your laboratory is now designated to act as a Conformity Assessment Body (CAB) under Appendix B, **Phase I** Procedures, of the APEC Tel MRA. The pertinent information about the laboratory's designation is as follows:

CAB Name: SIEMIC, Inc.
Physical Location: 2206 Ringwood Avenue, San Jose, CA 95131
Identification No.: US0160
Previous Scope: LP0002, PSTN01, ADSL01, ID0002, IS6100, CNS 14336, PLMN07
Current Scope: LP0002, PSTN01, ADSL01, ID0002, IS6100, CNS 14336, PLMN07, PLMN01 and PLMN08

You may submit test data to NCC to verify that the equipment to be imported into Chinese Taipei satisfies the applicable requirements. The designation of your organization will remain in force as long as its accreditation for the designated scope remains valid and comply with the designation requirements.

Recognized CABs are listed on the NIST website at <http://ts.nist.gov/mra>. If you have any questions please contact Ramona Saar at (301) 975-5521 or ramona.saar@nist.gov.

Sincerely,

David F. Alderman
Standards Services Group

Enclosure

cc: Ramona Saar

NIST

SIEMIC ACCREDITATION DETAILS: Vietnam CAB ID: US0160

UNITED STATES DEPARTMENT OF COMMERCE
National Institute of Standards and Technology
 Gaithersburg, Maryland 20899

July 11, 2012

Mr. Leslie Bai
 SIEMIC, Inc.
 2206 Ringwood Avenue
 San Jose, CA 95131

Dear Mr. Bai:

NIST is pleased to inform you that your laboratory continues to be recognized by Vietnam's Ministry of Information and Communication (MIC) under the Asia Pacific Economic Cooperation for Telecommunications Equipment Mutual Recognition Arrangement (APEC Tel MRA). MIC has updated your scope of recognition. The pertinent information about the continued recognition is as follows:

CAB Name: SIEMIC, Inc.
Physical Location: 2206 Ringwood Avenue, San Jose, CA 95131
Identification No.: US0160
Current Scope: TCN68-188, TCN68-190, TCN68-193, TCN68-196, TCN68-143, TCN68-192, TCN68-189, TCN68-221, TCN68-222, TCN68-223, TCN68-245, TCN68-242, TCN68-243, TCN68-246, TCVN 7189
Updated Scope: QCVN 19:2010/BTTTT, QCVN 22:2010/BTTTT, TCVN 7189:2009, TCVN 7317:2003, QCVN 10:2010/BTTTT, QCVN 12:2010/BTTTT, QCVN 3:2010/BTTTT, QCVN 15:2010/BTTTT, QCVN 11:2010/BTTTT, QCVN 54:2011/BTTTT, QCVN 55:2011/BTTTT, QCVN 18:2010/BTTTT, QCVN 17:2010/BTTTT

You may submit test data to MIC to verify that the equipment to be imported into Vietnam satisfies the applicable requirements. *Please note that your recognition from Vietnam will expire on **September 30, 2012**. To continue the recognition beyond this date, it will be necessary to submit to NIST the updated ISO/IEC 17025 Scope and Certification of Accreditation as soon as it is reissued during your next accreditation renewal period. NIST will then submit the updated information to MIC so that the recognition can be extended.*

Recognized CABs are listed on the NIST website at <http://gsi.nist.gov/global/index.cfm?l=1-4/l2-16/l3-90/A-380>. If you have any questions please contact Ramona Saar via email at ramona.saar@nist.gov or phone at (301) 975-5521.

Sincerely,

David F. Alderman
 Standards Services Group

Enclosure

cc: Ramona Saar

NIST

A

SIEMIC, Inc.

Accessing global markets

Title: RF Test Report of RF Switched Outlet
 Model: ARPS15RF2W4 / ARPS15RF2M4
 To: FCC 15.247:2011, RSS-210 Issue 8:2010

Serial# RF_SL12062002-LHS-007_FCC-IC
 Issue Date Nov 27th, 2012
 Page 70 of 74
 www.siemic.com

SIEMIC ACCREDITATION DETAILS: Mexico NOM Recognition

CAMARA NACIONAL
 DE LA INDUSTRIA
 ELECTRONICA, DE
 TELECOMUNICACIONES
 E INFORMÁTICA

Laboratorio Valentín V. Rivero

México D.F. a 16 de octubre de 2006.

**LESLIE BAI
 DIRECTOR OF CERTIFICATION
 SIEMIC LABORATORIES, INC.
 ACCESSING GLOBAL MARKETS
 P R E S E N T E**

En contestación a su escrito de fecha 5 de septiembre del año en curso, le comento que estamos muy interesados en su intención de firmar un Acuerdo de Reconocimiento Mutuo, para lo cual adjunto a este escrito encontrara el Acuerdo en idioma inglés y español prellenado de los cuales le pido sea revisado y en su caso corregido, para que si está de acuerdo poder firmarlo para mandarlo con las autoridades Mexicanas para su visto bueno y así poder ejercer dicho acuerdo.

Aprovecho este escrito para mencionarle que nuestro intermediario gestor será la empresa Isabel de México, S. A. de C. V., empresa que ha colaborado durante mucho tiempo con nosotros en lo relacionado a la evaluación de la conformidad y que cuenta con amplia experiencia en la gestoría de la certificación de cumplimiento con Normas Oficiales Mexicanas de producto en México.

Me despido de usted enviándole un cordial saludo y esperando sus comentarios al Acuerdo que nos ocupa.

Atentamente:

**Ing. Faustino Gomez González
 Gerente Técnico del Laboratorio de
 CANIETI**

Calle 71
 Huetamo Cuatrecasas
 08100 México, D.F.
 Tel: 5264 0000 con 12 líneas
 Fax: 5264 0495
 www.canieti.org

SIEMIC ACCREDITATION DETAILS: Hong Kong OFTA CAB ID : US0160

UNITED STATES DEPARTMENT OF COMMERCE
National Institute of Standards and Technology
Gaithersburg, Maryland 20899-

December 8, 2008

Mr. Leslie Bai
SIEMIC, Inc.
2206 Ringwood Avenue
San Jose, CA 95131

Dear Mr. Bai:

NIST is pleased to inform you that your laboratory has been recognized by the Office of the Telecommunications Authority (OFTA) under the Asia Pacific Economic Cooperation for Telecommunications Equipment Mutual Recognition Arrangement (APEC Tel MRA). Your laboratory is now designated to act as a Conformity Assessment Body (CAB) under Appendix B, **Phase I** Procedures, of the APEC Tel MRA. The pertinent information about your laboratory's designation is as follows:

CAB Name: SIEMIC, Inc.
Physical Location: 2206 Ringwood Avenue, San Jose, California 95131 USA
Identification No.: US0160
Recognized Scope: **Radio:** HKTA 1002, 1007, 1008, 1010, 1015, 1016, 1020, 1022, 1026, 1027, 1029, 1030, 1031, 1032, 1033, 1034, 1035, 1036, 1037, 1039, 1041, 1042, 1043, 1044, 1046, 1047, 1048, 1049, 1051
Telecom: HKTA 2011, 2012, 2013, 2014, 2017, 2018, 2022, 2024, 2026, 2027, 2028, 2029, 2030, 2031, 2032, 2033

You may submit test data to OFTA to verify that the equipment to be imported into Hong Kong satisfies the applicable requirements. The designation of your organization will remain in force as long as its accreditation for the designated scope remains valid and comply with the designation requirements.

Recognized CABs are listed on the NIST website at <http://ts.nist.gov/mra>. If you have any questions please contact Ramona Saar at (301) 975-5521 or ramona.saar@nist.gov.

Sincerely,

A handwritten signature in black ink that reads "David F. Alderman".

David F. Alderman
Group Leader, Standards Coordination and Conformity Group
Standards Services Division

Enclosure

cc: Ramona Saar

The logo for the National Institute of Standards and Technology (NIST), consisting of the letters "NIST" in a bold, sans-serif font.

A

SIEMIC, Inc.

Accessing global markets

Title: RF Test Report of RF Switched Outlet
Model: ARPS15RF2W4 / ARPS15RF2M4
To: FCC 15.247:2011, RSS-210 Issue 8:2010

Serial# RF_SL12062002-LHS-007_FCC-IC
Issue Date Nov 27th, 2012
Page 72 of 74
www.siemic.com

SIEMIC ACCREDITATION DETAILS: Australia ACMA CAB ID: US0160

UNITED STATES DEPARTMENT OF COMMERCE
National Institute of Standards and Technology
Gaithersburg, Maryland 20899

November 20, 2008

Mr. Leslie Bai
SIEMIC, Inc.
2206 Ringwood Avenue
San Jose, CA 95131

Dear Mr. Bai:

NIST is pleased to inform you that your laboratory has been recognized by the Australian Communications and Media Authority (ACMA) under the Asia Pacific Economic Cooperation for Telecommunications Equipment Mutual Recognition Arrangement (APEC Tel MRA). Your laboratory is now designated to act as a Conformity Assessment Body (CAB) under Appendix B, **Phase I** Procedures, of the APEC Tel MRA. The pertinent information about your laboratory's designation is as follows:

CAB Name: Siemic, Inc.
Physical Location: 2206 Ringwood Avenue, San Jose, CA 95131
Identification No.: US0160
Recognized Scope: EMC: AS/NZS 4251.1 (until 5/31/2009), AS/NZS 4251.2 (until 5/31/2009), AS/NZS CISPR 11, AS/NZS CISPR 14.1, AS/NZS CISPR 22, AS/NZS 61000.6.3, AS/NZS 61000.6.4
Radiocommunications: AS/NZS 4281, AS/NZS 4268, AS/NZS 4280.1, AS/NZS 4280.2, AS/NZS 4295, AS/NZS 4582, AS/NZS 4583, AS/NZS 4769.1, AS/NZS 4769.2, AS/NZS 4770, AS/NZS 4771
Telecommunications: AS/ACIF S002:05, AS/ACIF S003:06, AS/ACIF S004:06, AS/ACIF S006:01, AS/ACIF S016:01, AS/ACIF S031:01, AS/ACIF S038:01, AS/ACIF S040:01, AS/ACIF S041:05, AS/ACIF S043.2:06, AS/NZS 60950.1

You may submit test data to ACMA to verify that the equipment to be imported into Australia satisfies the applicable requirements. The designation of your organization will remain in force as long as its accreditation for the designated scope remains valid and comply with the designation requirements. Recognized CABs are listed on the NIST website at <http://ts.nist.gov/mra>. Please contact Ms. Ramona Saar, at (301) 975-5521 or ramona.saar@nist.gov if you have questions.

Sincerely,

A handwritten signature in black ink that reads "David F. Alderman".

David F. Alderman
Group Leader, Standards Coordination and Conformity Group
Standards Services Division

Enclosure

cc: Snell Leong, Siemic, Inc.; Ramona Saar, NIST

The logo for the National Institute of Standards and Technology (NIST), consisting of the letters "NIST" in a bold, sans-serif font.

SIEMIC ACCREDITATION DETAILS: Australia NATA Recognition

Leslie Bai
SIEMIC, Inc.
2206 Ringwood Avenue
San Jose, CA 95131

November 4, 2008

Under Australian government legislation, the Australian Communications and Media Authority (ACMA) has determined the National Association of Testing Authorities, Australia (NATA) as an accreditation body as per Section 409(1) of the Telecommunications Act 1997 (Cth). Pursuant to Section 409(2) of the Telecommunications Act 1997 (Cth), I am pleased to advise that your laboratory has been determined as a Recognised Testing Authority (RTA).

This determination has been made on the basis of your accreditation by A2LA accreditation no. 2742.01 and the Mutual Recognition Agreement between NATA and A2LA. It is effective from 11 July 2008. RTA status applies only to the following standards and is contingent upon their continued inclusion in your laboratory's scope of accreditation.

**AS/ACIF S002, AS/ACIF S003, AS/ACIF S004,
AS/ACIF S006, AS/ACIF S016, AS/ACIF S031,
AS/ACIF S038, AS/ACIF S041 and
AS/ACIF S043.2**

As an RTA, your laboratory has the following obligations:

1. the laboratory shall continue to meet all of the accreditation criteria of A2LA;
2. the authorised representative of the laboratory shall notify NATA of changes to the staff or operations of the laboratory which would affect the performance of the tests for which the laboratory has been determined;
3. compliance of equipment shall be reported on test reports bearing the A2LA logo/endorsement.

Current information on the Australian Communications and Media Authority and regulatory requirements for telecommunications products within Australia can be obtained from the ACMA's web-site at "<http://www.acma.gov.au>". Further information about NATA may be gained by visiting "<http://www.nata.asn.au>".

Please note that AS/ACIF S040 and New Zealand standards do not form part of the RTA scheme.

Your RTA listing will appear on the NATA website shortly.

Kind Regards

Chris Norton,
Senior Scientific Officer
Measurement Science and Technology
National Association of Testing Authorities (NATA)
71-73 Flemington Road
North Melbourne Vic 3051
Australia
Ph: +61 3 9329 1633 Fx: +61 3 9326 5148
E-Mail: Christopher.Norton@nata.asn.au
Internet: www.nata.asn.au

SIEMIC ACCREDITATION DETAILS: VCCI Radiated Test Site Registration No. A-0133

Certificate of VCCI Laboratory registration

1. Registration Information		
1.1 Laboratory Info.	Company name (VCCI Membership No.)	SIEMIC Laboratories (3081)
	Laboratory Name	SIEMIC Labs (Milpitas location)
	VCCI Laboratory registration No.	A-0133
	VCCI Laboratory registration date	09/21/2012 (mm/dd/yyyy)
	Registration expiration date	09/30/2014 (mm/dd/yyyy)
	Country of Laboratory	USA
	ISO 17025 Accreditation body name	A2LA
	Accreditation No.	2742.01
	Accreditation valid to mm/dd/yyyy	09/30/2014 (mm/dd/yyyy)
	Edition (year) of the VCCI rule indicated in the scope of accreditation (example: V-3 20xx.04)	Not described in Scope
	Zip code	95035
Address	775 Montague Expressway, Milpitas , CA 95035 USA	



VCCI Council